

mtco.

工業用ミシン部品カタログ

Industrial Sewing Machine Parts Catalog

Model PLK-J4040R

目次	CONTENTS	Page
A 全体構成	Construction	1
B 本体関係 (1)	Arm bed & it's accessories (1)	2
C 本体関係 (2)	Arm bed & it's accessories (2)	4
D 本体関係 (3)	Arm bed & it's accessories (3)	6
E 本体関係 (4)	Arm bed & it's accessories (4)	8
F 縫い機構	Sewing mechanism	10
G デジタルテンション機構	Digital tension mechanism	12
H 中押え・ワイパー機構	Presser bar lifting mechanism & Wiper mechanism	14
J かま台機構	Hook saddle mechanism	16
K 糸切り機構	Thread trimming mechanism	18
L X-Yテーブル機構	X-Y table mechanism	20
M チャッキング装置	Jig eject system	22
N 配線配管関係	Cable component & Pneumatic control unit	24
P 給油機構	Oil lubrication mechanism	26
Q テーブル関係	Table & Stand	28
R 付属品	Accessories	30
S オプションパーツ	Option parts	32
索引	Index	34

部品コードの採番形式

SPARE PARTS No. Designation system

1. 部品コードについて CONCERNING PARTS CODE.

部品をご注文される場合は、部品コードをお知らせください。
Please inform the part number, when these parts are ordered.

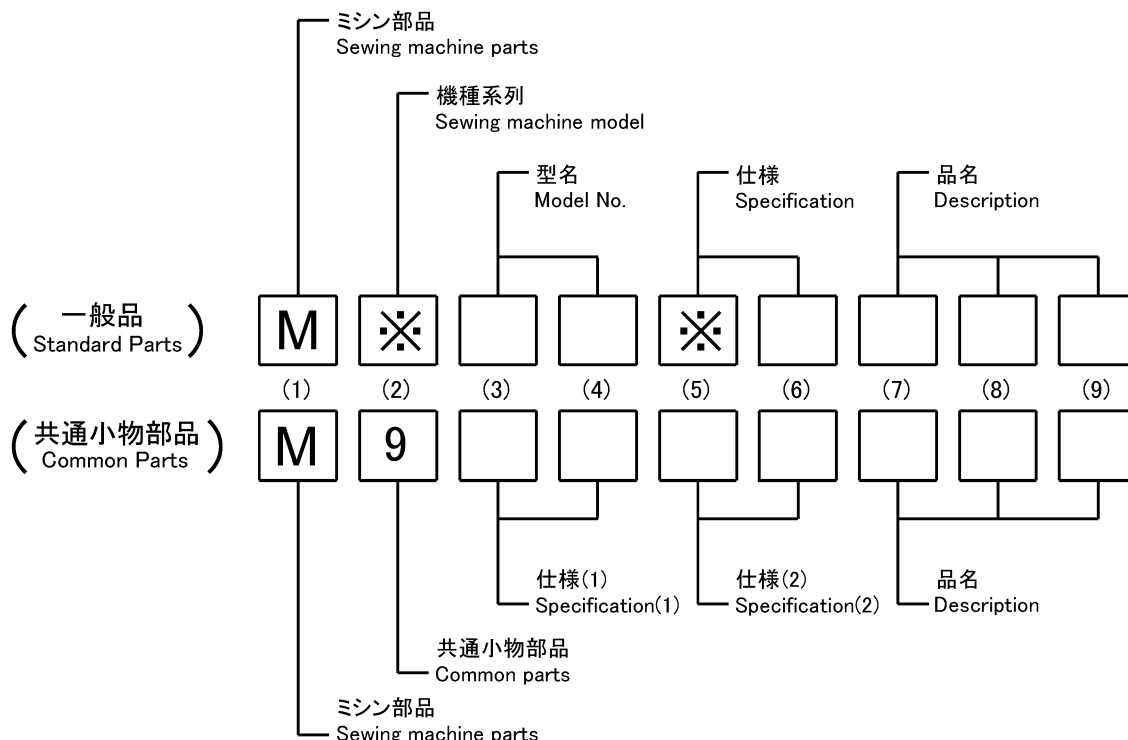

【 例 】 Example

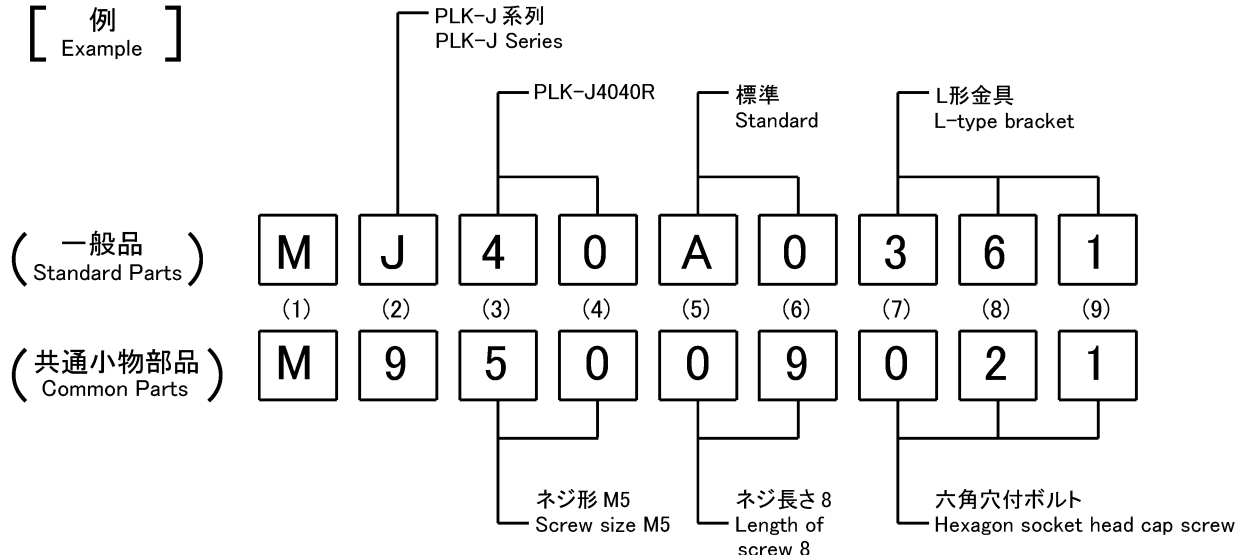

2. 変更マークについて CONCERNING MODIFICATION MARK.

変更マーク欄に* 記号のある部品は、形状、寸法などの変更履歴がありますので、ご注文の際にはご使用の製品の製造番号と合わせてご覧ください。

The parts marked with * in the modification column has been changed the shape or size etc. So when these modified parts are ordered please inform the serial number of the sewing machine.

注：一般品についての機種型名は、その部品が最初に使用された機種型名を示します。従って長期にわたる場合は、機種の変更が行われるため、当初の機種以外の機種で使用されている場合があります。

Sewing machine Models, of Standard Parts are Indicated model of these parts are registered firstly. Parts are used for not only the indicated model, but also another models, in reason of New development, improvement after.

A 全体構成
CONSTRUCTION

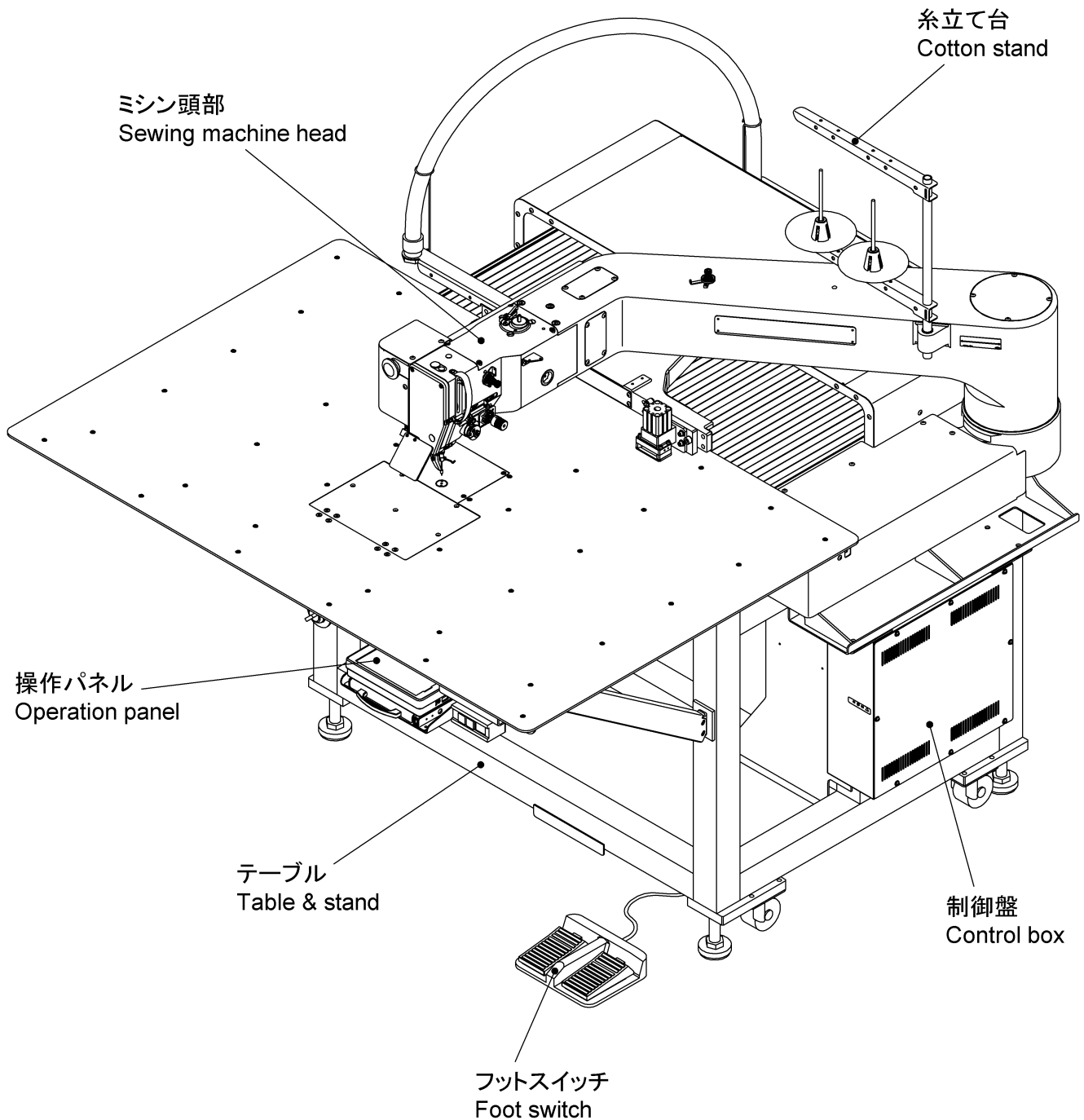

注1 : Fig.No.の採番していない部品は単体で支給することは出来ません。セットにて支給いたします。

Remarks 1) The parts which Fig.No. are not marked are not available individually.
It can be supplied with the whole component.

B 本体関係 (1)
ARM BED & IT'S ACCESSORIES (1)

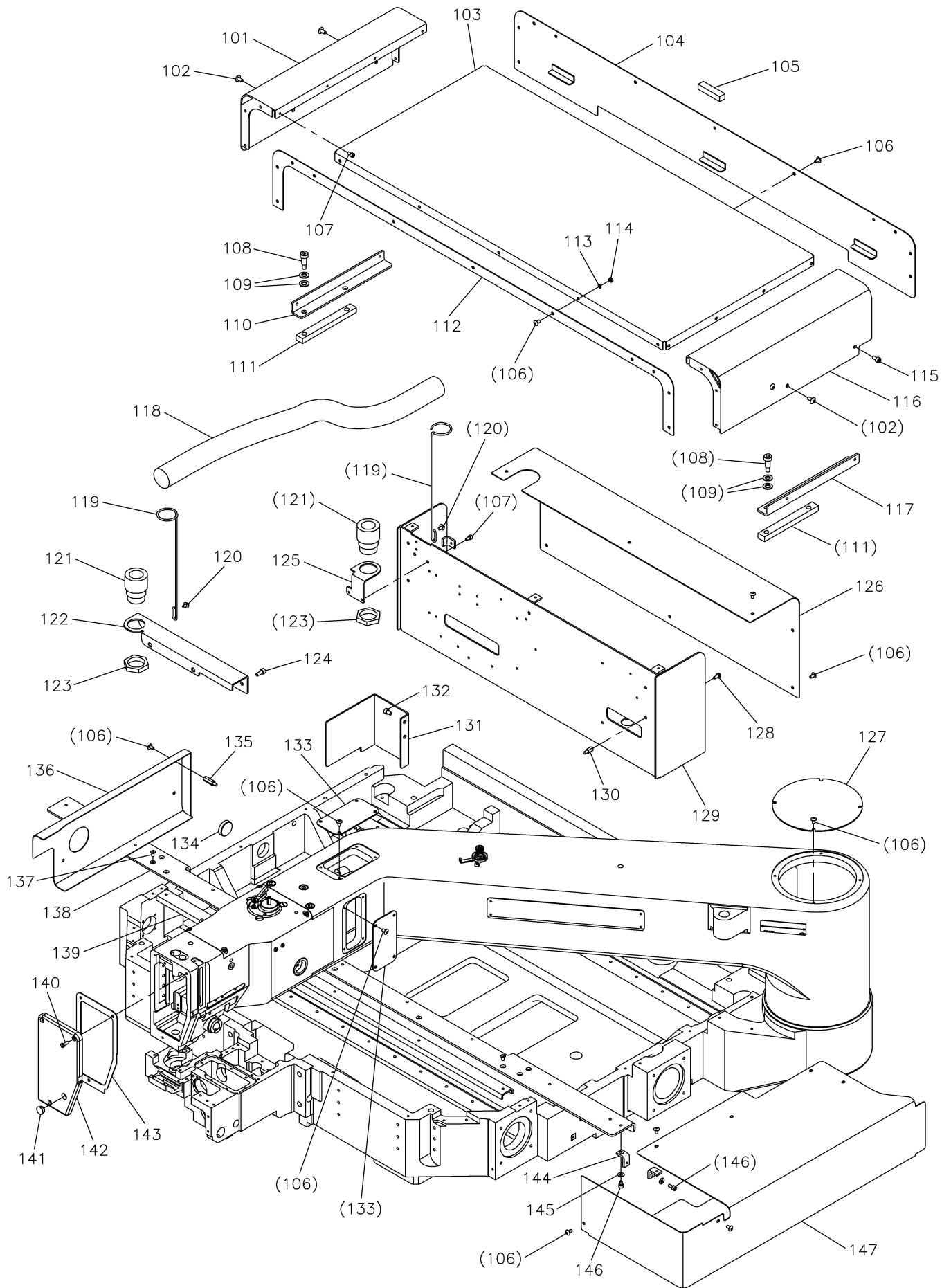

[B] 本体関係(1)

ARM BED & IT'S ACCESSORIES (1)

Fig no.	変更 Mod.	部品コード Parts no.	品名	Description	数量 Amt. Req.
B 101		MJ60A1339	X-Yカバー ヒタリ	X-Y cover (left)	1
☆ B 102		M95001036	PTラスネジ M5X10	Truss screw M5X10	3
B 103		MJ60A2339	X-Yカバー ウエ	X-Y cover (upper)	1
B 104		MJ60A4339	X-Yカバー ウシロ	X-Y cover (rear)	1
B 105		MJ60A0416	ゴムイタ A	Rubber plate A	3
☆ B 106		M94001036	トラスネジ M4X8	Truss screw M4X8	52
☆ B 107		M94008017	セフティソケット M4X6	Safety socket bolt M4X6	10
B 108		M98002031	ストリッパホルト	Stripper bolt	4
B 109		M90825050	コサガネ 8	Small washer 8	8
B 110		MJ60A2601	X-Yカバー トリツケイタ ヒタリ	X-Y cover adapter (left)	1
B 111		MJ60A1416	ゴムイタ B	Rubber plate B	2
B 112		MJ60A3339	X-Yカバー マエ	X-Y cover (front)	1
☆ B 113		M90422050	コサガネ 4	Small washer 4	10
☆ B 114		M91007045	ナット M4	Nut M4	10
☆ B 115		M95053021	ロッカクアナツキホルト M5X6	Socket bolt M5X6	1
B 116		MJ60A0339	X-Yカバー クミタテ ミキ	X-Y cover assy (right)	1
B 117		MJ60A1601	X-Yカバー トリツケイタ ミキ	X-Y cover adapter (right)	1
B 118		MJ60A0567	フレキシブルチューブ	Flexible tube	1
B 119		MJ60A1780	ホルダクミタテ	Holder assy	2
☆ B 120		M91071004	SW-MWプライマインネジ M4X8	SW-MW pan screw M4X8	4
B 121		MJ60A1422	コネクター	Connector	2
B 122		MJ60A0601	コネクタトリツケイタ	Connector bracket	1
B 123		M95025045	ロッカクナット	Nut	2
☆ B 124		M95003021	ロッカクアナツキホルト M5X12	Socket bolt M5X12	2
B 125		MJ60B1601	コネクタトリツケイタ	Connector bracket	1
B 126		MJ60B6339	キハンボックスカバー	Print circuit board box cover	1
B 127		MJ60A1742	アームフタ	Arm cover	1
☆ B 128		K14S90203410	SW-PW Pナネジ M4X10	SW-PW pan screw M4X10	5
B 129		MJ60A0696	キハンボックス	Print circuit board box	1
B 130		MJ60A2476	スペーサホルト	Spacer bolt	5
B 131		MJ60A8339	カバー	Cover	1
B 132		M95009021	ロッカクアナツキホルト M5X8	Socket bolt M5X8	2
B 133		MJ60B3339	アームカバー	Arm cover	2
B 134		MJ60A1500	ゴムセン φ33.5	Rubber plug φ33.5	1
B 135		MJ60A4476	スペーサホルト	Spacer bolt	4
B 136		MJ60A5339	アームソクメンカバー	Cover	1
☆ B 137		M90449037	Pサラネジ M4X8	Countersunk screw M4X8	9
B 138		MJ60A0799	ホキョウイタ ウシロ	Stiffening plate (rear)	1
B 139		MJ60A0161	ウラアテイタ	Stiffening plate (back)	1
☆ B 140		M90991002	ヒラネジ M4X12	Flat screw M4X12	3
☆ B 141		M91182080	セン φ11.8	Rubber plug φ11.8	1
B 142		MJ61A1830	メンイタ	Face cover	1
B 143		MJ60A0691	ガスケット	Gasket	1
☆ B 144		MB62A4601	トリツケイタ	Adapter	2
☆ B 145		M90421050	ミカキサガネ 4	Large washer 4	2
☆ B 146		M94002017	セフティソケット M4X8	Safety socket bolt M4X8	2
B 147		MJ60A0849	モータカバー	Motor cover	1

C 本体関係 (2)
ARM BED & IT'S ACCESSORIES (2)

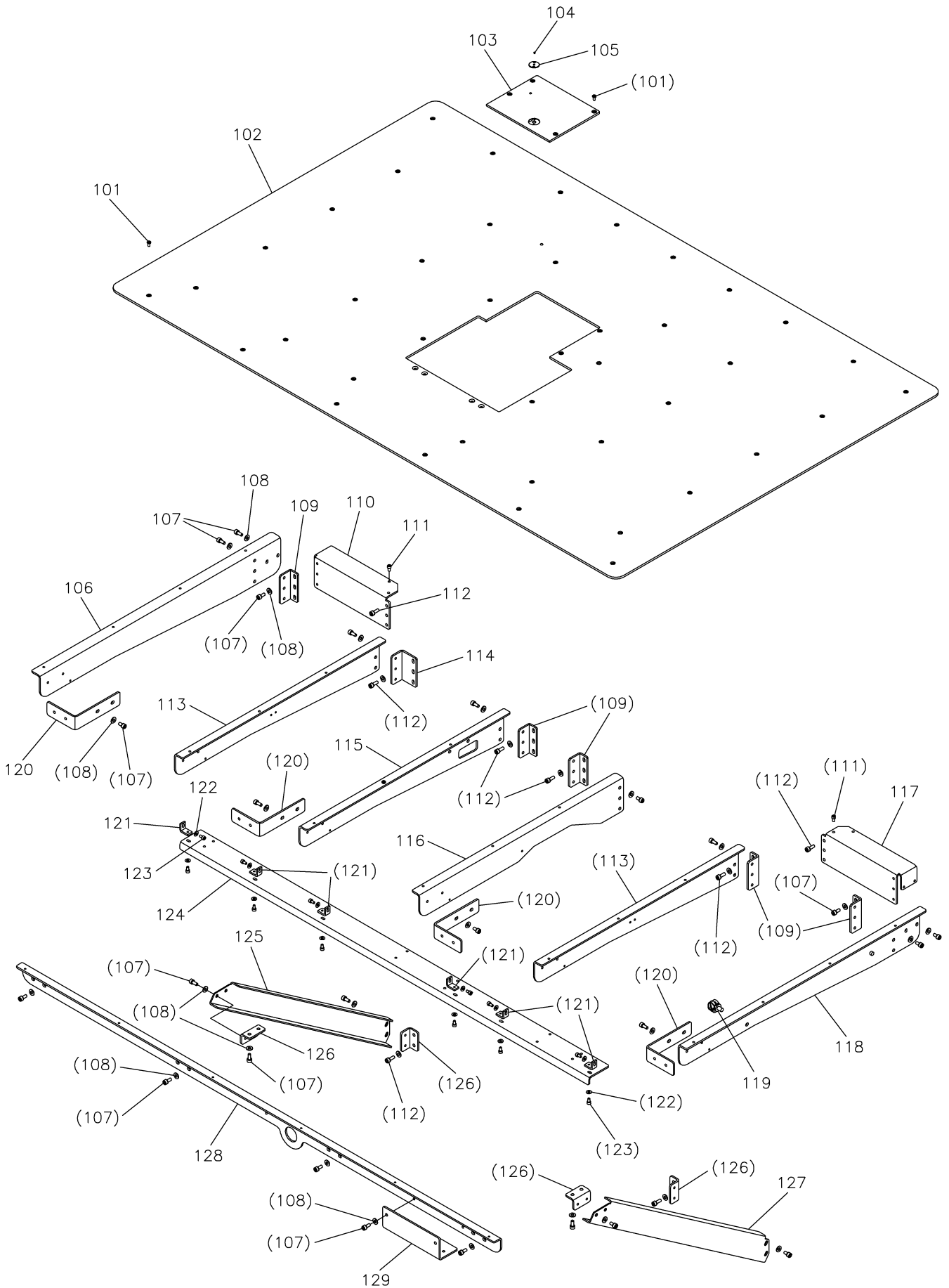

[C] 本体関係(2)

ARM BED & IT'S ACCESSORIES (2)

Fig no.	変更 Mod.	部品コード Parts no.	品名	Description	数量 Amt. Req.
☆ C	101	M90990002	ヒラネジ M4X8	Flat screw M4X8	45
C	102	MJ60A0470	スベリ板	Slide plate	1
C	103	MJ60A0472	スベリ板	Slide plate	1
☆ C	104	M90605010	サラネジ 2/32(56)X2.8	Countersunk screw 2/32(56)X2.8	2
☆ C	105	MS02A1101	ハリ板 φ2.2	Needle plate φ2.2	1
C	106	MJ60A3429	ササエカナグ D	Bracket D	1
☆ C	107	M95005017	セフティソケット M5X10	Safety socket bolt M5X10	58
☆ C	108	M90511050	ミキサガネ 5	Large washer 5	74
C	109	MA20A0361	L型タカナグ	L-type bracket	5
C	110	MJ60A2758	ササエカナグブラケット ヒダリ	Bracket (left)	1
☆ C	111	M94001017	セフティソケット M4X10	Safety socket bolt M4X10	4
☆ C	112	M95002017	セフティソケット M5X12	Safety socket bolt M5X12	22
C	113	MJ60A1429	ササエカナグ B	Bracket B	2
C	114	ME60A0361	L型タカナグ	L-type bracket	1
C	115	MJ60A4429	ササエカナグ E	Bracket E	1
C	116	MJ60A0429	ササエカナグ A	Bracket A	1
C	117	MJ60A1758	ササエカナグブラケット ミキ	Bracket (right)	1
C	118	MJ60A2429	ササエカナグ C	Bracket C	1
☆ C	119	MH40A1620	ホルダクリップ	Holder clip	2
☆ C	120	ME40A0758	ブラケット	Bracket	4
☆ C	121	MB62A4601	トリツケイタ	Adapter	6
☆ C	122	M90421050	ミキサガネ 4	Large washer 4	12
☆ C	123	M94002017	セフティソケット M4X8	Safety socket bolt M4X8	12
C	124	MJ60A0426	サポート2	Supporter 2	1
C	125	MJ60A2426	サポート1 ヒダリ	Supporter 1 (left)	1
C	126	MJ40A0361	L型タカナグ	L-type bracket	4
C	127	MJ60A1426	サポート1 ミキ	Supporter 1 (right)	1
C	128	MJ60A1799	ホキョウイタ マエ	Stiffening plate (front)	1
C	129	MJ60B2601	SWトリツケイタ	Switch adapter	1

D 本体関係 (3)
ARM BED & IT'S ACCESSORIES (3)

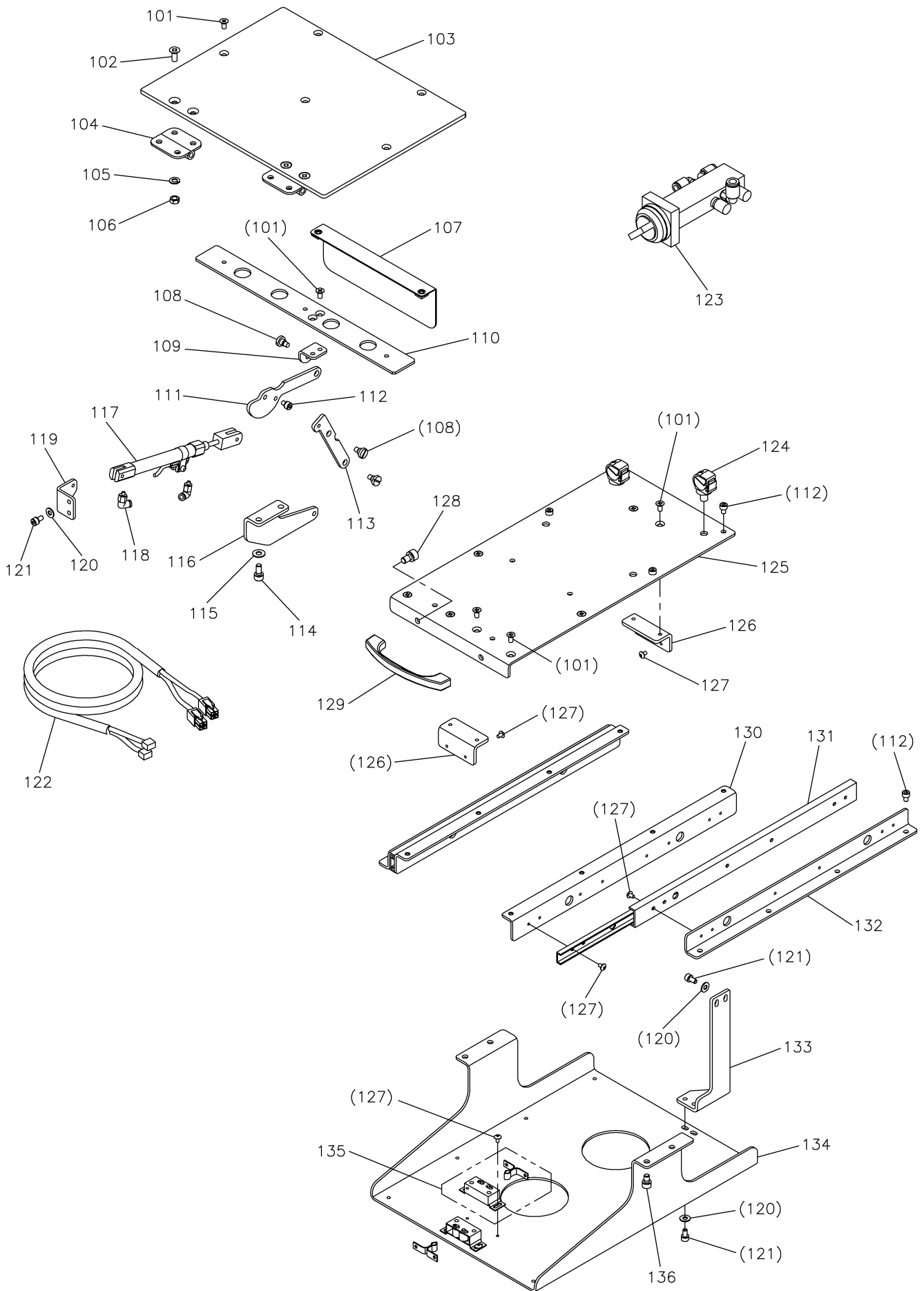

[D] 本体関係(3)

ARM BED & IT'S ACCESSORIES (3)

Fig no.	変更 Mod.	部品コード Parts no.	品名	Description	数量 Amt. Req.
☆ D 101		M90449037	Pサラネジ M4X8	Countersunk screw M4X8	15
D 102		M90522037	Pサラネジ M5X10	Countersunk screw M5X10	8
D 103		MJ60A0742	スベリ板 フタ	Flap plate	1
D 104		MH50A0739	ヒンジ	Hinge	2
D 105		M90522050	サラネサガネ 5	Conical spring washer 5	8
☆ D 106		M91384045	トメナット M5	Nut M5	8
D 107		MJ60B2339	ショウメンカマカバー	Hook cover	1
☆ D 108		M91127015	ヒラネジダットツキ 11/64(40)X5	Shoulder bolt 11/64(40)X5	3
D 109		MJ60A0739	ヒンジ1	Hinge 1	1
D 110		MJ60A0237	カイヘイウライタ	Stopper plate	1
D 111		MJ60A1910	リンク1	Link 1	1
☆ D 112		M94001021	ロッカクアナツキホルト M4X6	Socket bolt M4X6	13
D 113		MJ60A2910	リンク2	Link 2	1
☆ D 114		M95005017	セフティソケット M5X10	Safety socket bolt M5X10	2
☆ D 115		M90511050	ミカキサガネ 5	Washer 5	2
D 116		MJ60A1739	ヒンジ2	Hinge 2	1
D 117		MJ60A0434	エアシリンダ	Air cylinder	1
D 118		MB61A1571	エルボユニオン	Connector	2
D 119		MJ60A8601	シリンダトリツケイタ	Cylinder bracket	1
☆ D 120		M90421050	ミカキサガネ 4	Large washer 4	6
☆ D 121		M94002017	セフティソケット M4X8	Safety socket bolt M4X8	6
D 122		MJ60A8508	ケーブル(ホヒンマト/イトキリセンサ)	Cable (flap plate/TRIM sensor)	1
D 123		MJ60A1599	メカニカルバルブ	Mechanical operated valve	1
☆ D 124		MH40A0620	ホルダクリップ	Holder clip	2
D 125		MJ60A0595	レールテンイタ	Top panel	1
☆ D 126		MH40A2601	ウケトリツケイタ	Bracket	2
☆ D 127		M90302036	トラスコネジ M3X5	Truss screw M3X5	32
☆ D 128		M96008017	セフティソケット M6X10	Safety socket bolt M6X10	2
D 129		MJ60A0602	トッテ	Handle	1
☆ D 130		MH40A1958	レールウエ	Rail (upper)	2
☆ D 131		MH40A2958	スライドレール	Slide rail	2
☆ D 132		MH40A0958	レールシタ	Rail (lower)	2
D 133		MJ60A2799	ホキョウイタ	Stiffening plate	1
D 134		MJ60A1770	PALトリツケベース	PAL base	1
☆ D 135		MH40A0809	ローラーキャッチ	Roller catch	2
☆ D 136		M95003017	セフティソケット M5X8	Safety socket bolt M5X8	4

E 本体関係 (4)
ARM BED & IT'S ACCESSORIES (4)

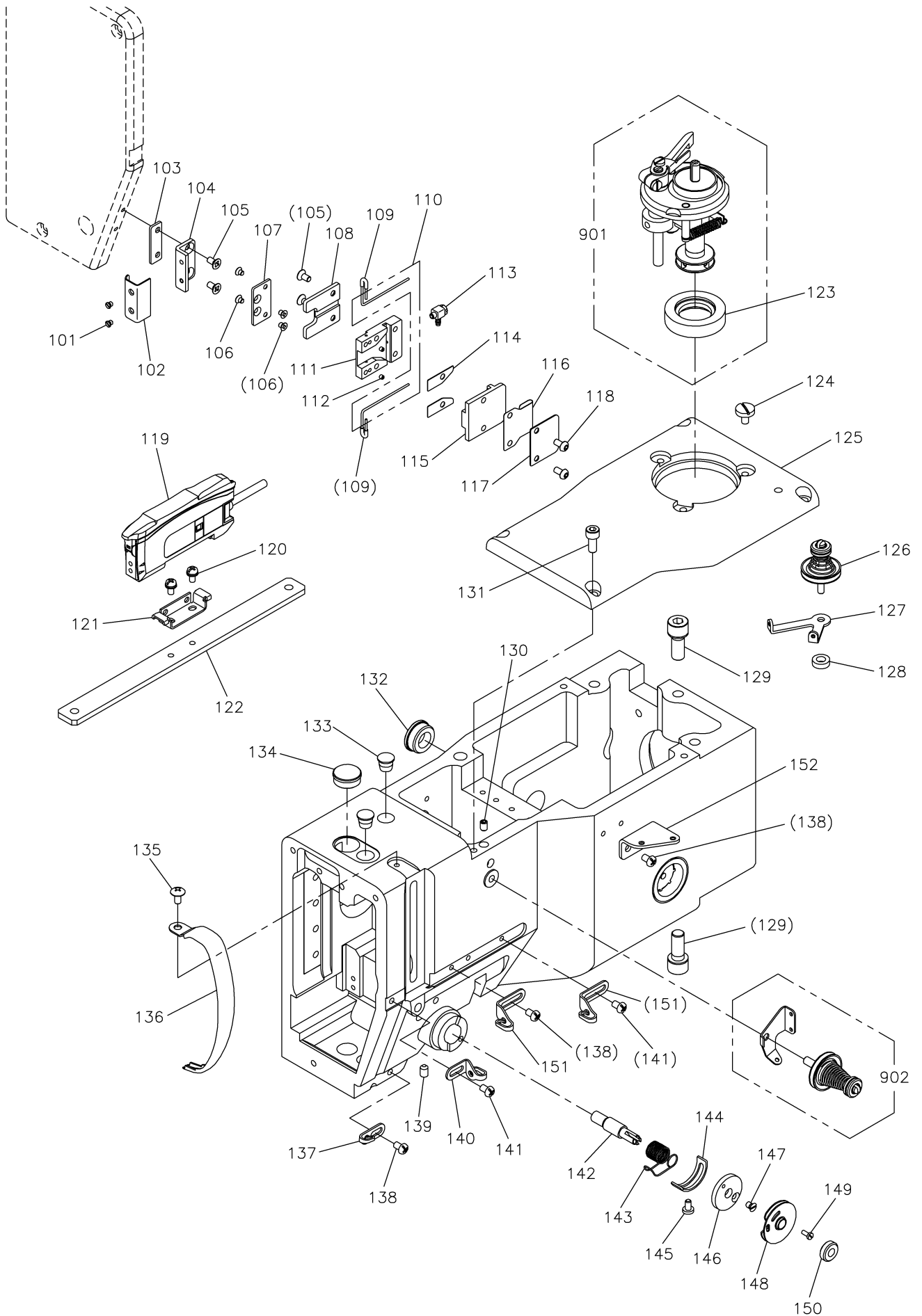

[E] 本体関係(4)

ARM BED & IT'S ACCESSORIES (4)

Fig no.	変更 Mod.	部品コード Parts no.	品名	Description	数量 Amt. Req.
☆ E 101		M90605010	サラネジ 3/32(56)X2.8	Countersunk screw 3/32(56)X2.8	2
E 102		MJ61A2339	カバー	Cover	1
E 103		MJ61A0476	ベーススペーサ	Base spacer	1
E 104		MJ61A0758	ブラケット	Bracket	1
E 105		M90858004	Pサラネジ M3X6	Countersunk screw M3X6	4
E 106		M92000010	サラネジ M2.5X3	Countersunk screw M2.5X3	4
E 107		MJ61A0601	トリツケイタ	Adapter	1
E 108		MJ61A0770	ハイセンベース	Wiring base	1
E 109		MJ61A0567	ビニールチューブ	Tube	2
E 110		MJ61A0757	ファイバユニット	Optical fiber unit	1
E 111		MJ61A1770	メインベース	Main base	1
E 112		M92004020	ロッカクアナツキトメネジ M2X2	Set screw M2X2	2
E 113		MJ61A0571	カンツキテ	Connector	1
E 114		MJ61A1476	スペーサ	Spacer	2
E 115		MJ61A1742	ベースフタ	Base cover	1
E 116		MJ40A0626	ガード	Guard	1
E 117		MJ40A0257	ハサミタ	Plate	1
E 118		M93000022	ロッカクアナツキボタンホルト M3X6	Button bolt M3X6	2
E 119		MJ61A1757	ファイバアンプクミタテ	Optical fiber amplifier assy	1
☆ E 120		M90859004	SW-PWプラマイナネジ M3X6	SW-PW pan screw M3X6	2
E 121		MJ61A0602	トリツケカナガ	Holder	1
E 122		MJ61A1601	アンプトリツケイタ	Amplifier adapter plate	1
E 123		MH10A0417	ゴムワ	Rubber ring	1
E 124		M91150003	マルヒラネジ 11/64(40)X8	Flat screw 11/64(40)X8	3
E 125		MJ60A0600	トップカバー	Top cover	1
☆ E 126		MS14E0180	チョウセツクミタテ	Thread tension Regulator assy	1
☆ E 127		MS14A1180	イトアンナイ	Thread guide	1
☆ E 128		MG75A1476	スペーサ	Spacer	1
E 129		M98004017	セフティソケット M8X20	Safety socket bolt M8X20	6
☆ E 130		M91053020	ロッカクアナツキトメネジ M4X6	Set screw M4X6	1
☆ E 131		M95003021	ロッカクアナツキホルト M5X12	Socket bolt M5X12	4
☆ E 132		M91910080	ゴムセン φ19	Rubber plug φ19	1
E 133		M90883080	ゴムセン φ8.8	Rubber plug φ8.8	2
E 134		MJ60A0500	ゴムセン φ17	Rubber plug φ17	1
☆ E 135		M94001036	トラスネジ M4X8	Truss screw M4X8	1
E 136		MH10A0584	テンピンカバー	Thread take-up lever guard	1
☆ E 137		MF10A0181	イトアンナイ	Thread guide	1
☆ E 138		M91011004	プラマイナネジ M4X6	Pan screw M4X6	4
E 139		M91051020	ロッカクアナツキトメネジ M4X8	Set screw M4X8	1
E 140		MG43A1181	イトアンナイ	Thread guide	1
E 141		M91084004	プラマイナネジ M4X6	Pan screw M4X6	2
E 142		MP10B0554	チョウシジク	Thread tension stud	1
E 143		MP60A1187	イトトリハネ	Thread take-up spring	1
E 144		MN10A0477	ストップ	Stopper	1
☆ E 145		M90920002	ヒラネジ 9/64(40)X6.5	Flat screw 9/64(40)X6.5	1
E 146		MJ60A6770	イトトリベース	Thread take-up base	1
☆ E 147		M90907010	サラネジ 9/64(40)X5	Countersunk screw 9/64(40)X5	1
E 148		MN10E0175	イタクミタテ	Plate complete	1
E 149		M90602003	マルヒラネジ 3/32(56)X6	Flat screw 3/32(56)X6	1
E 150		M91603046	ツマミナット	Thumb nut	1
☆ E 151		MG43A0181	イトアンナイ	Thread guide	2
E 152		MH10A3181	イトアンナイ	Thread guide	1
E 901		MJ60E0190	イトマキソウチクミタテ	Bobbin winder complete	1
☆ E 902		MH10E0550	イトチョウセツクミタテ	Thread tension Regulator assy	1

☆印はPLK-G4030R共通部品を示します。

☆ indicates PLK-G4030R common parts.

F 縫い機構
SEWING MECHANISM

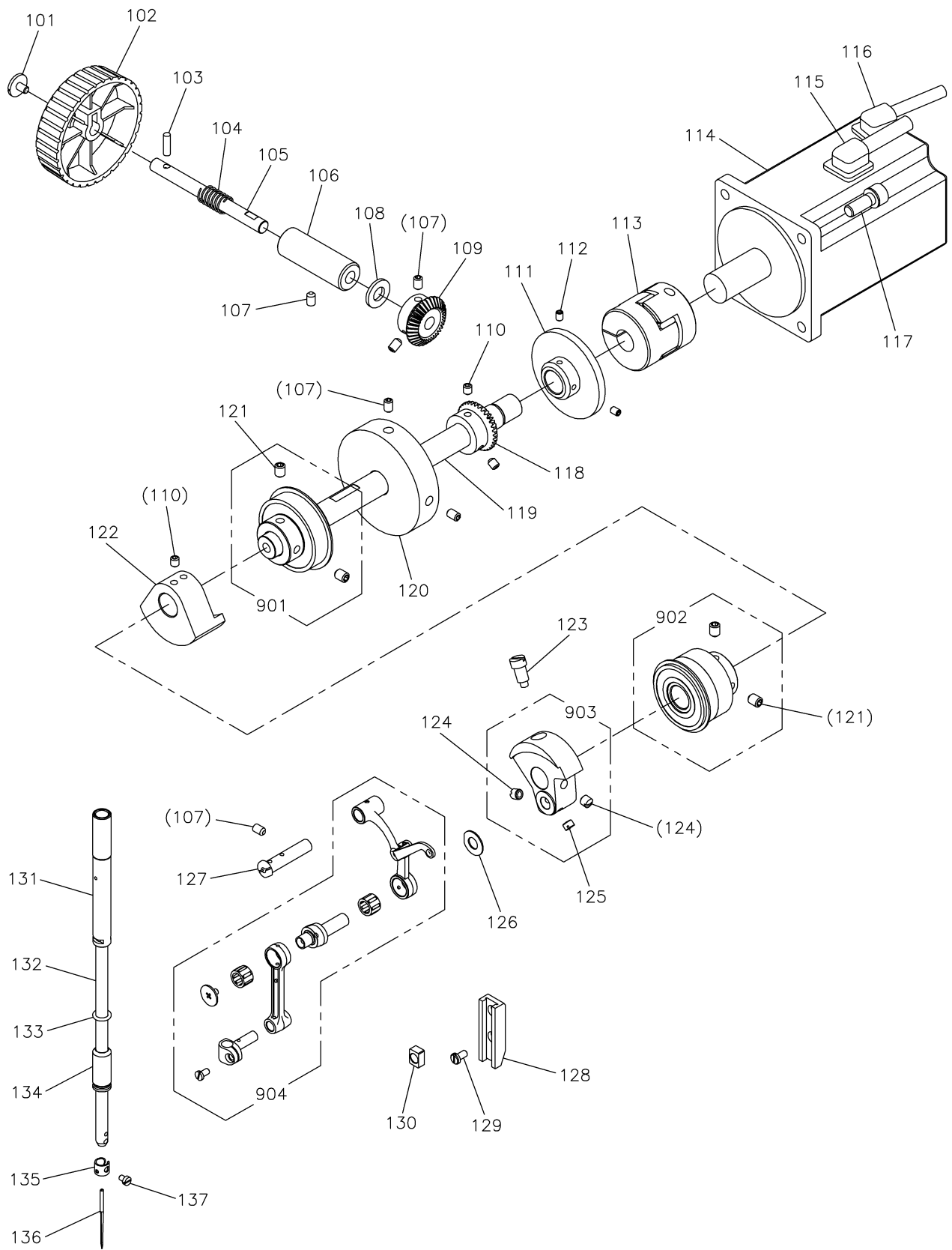

[F]縫い機構

SEWING MECHANISM

Fig no.	変更 Mod.	部品コード Parts no.	品名	Description	数量 Amt. Req.
☆ F 101		M91119002	ヒラネジ 11/64(40)X6.8	Flat screw 11/64(40)X6.8	1
F 102		MJ60A0682	プーリー	Hand pulley	1
☆ F 103		M90406064	スプリングピン 4X14	Spring pin φ4X14	1
☆ F 104		MH10A0572	ツルマキバネ	Spring	1
F 105		MH10A0454	シフト	Shaft	1
F 106		MH10A0833	メタル	Bushing	1
☆ F 107		M95004020	ロッカクアナツキトメネジ M5X8	Set screw M5X8	6
☆ F 108		MH10A0416	カンショウゴム	Rubber cushion	1
☆ F 109		MH10A0722	マイタキヤ	Gear	1
☆ F 110		M95002020	ロッカクアナツキトメネジ M5X6	Set screw M5X6	4
☆ F 111		MS14A0682	プーリー	Pulley	1
☆ F 112		M91053020	ロッカクアナツキトメネジ M4X6	Set screw M4X6	2
F 113		MJ60A0364	カップリング	Coupling	1
F 114		MJ60A2848	サーボモータ(シュシク)	Servomotor (upper shaft)	1
F 115		MJ60A9508	ケーブル(シュシクモータテンゲン)	Cable (upper shaft moter power)	1
F 116		MJ60A0508	ケーブル(シュシクモータエンコーダ)	Cable (upper shaft moter encoder)	1
☆ F 117		M96001017	セフティソケット M6X16	Safety socket bolt M6X16	4
☆ F 118		MH10A1722	ウワジクマイタキヤ	Gear	1
F 119		MJ60A0230	ウワジク	Upper shaft	1
F 120		MJ60A0383	イナーシャ	Inertia rotor	1
☆ F 121		M91650020	ロッカクアナツキトメネジ M6X8	Set screw M6X8	4
F 122		MJ60A0721	バランス	Balance weight	1
☆ F 123		M91802006	ヒラネジホウサキ 9/32(28)	Set screw 9/32(28)	1
☆ F 124		M91606001	トメネジ 1/4(40)X6	Set screw 1/4(40)X6	2
☆ F 125		M91602001	トメネジ 1/4(40)X4	Set screw 1/4(40)X4	1
F 126		M90836050	ワッシャ	Washer	1
F 127		MH10A0530	ダンツキシククミタテ	Stepped shaft assy	1
☆ F 128		MS01A0155	アンナイダイ	Guide bracket	1
☆ F 129		M90990002	ヒラネジ M4X8	Flat screw M4X8	2
☆ F 130		MF10A0325	カクコマ	Square block	1
☆ F 131		MH10A0663	ハリホウメタルウエ	Needle bar bushing (upper)	1
☆ F 132		MH27A0660	ハリホウ	Needle bar	1
☆ F 133		M90500085	Oリング	O-ring	1
F 134		MJ60A0664	ハリホウメタルシタ	Needle bar bushing (lower)	1
☆ F 135		MG42A0181	イトアンナイ	Thread guide	1
☆ F 136		MS02A0128	ミシンハリ DPX17-18	Needle DPX17 #18	1
☆ F 137		M90815002	ヒラネジ 1/8(44)X4.5	Flat screw 1/8(44)X4.5	1
F 901		MJ60E0456	シクウケクミタテ(ウワジクウシロ)	Ball bearing assy (rear)	1
F 902		MH10E0456	シクウケクミタテ(ウワジクマエ)	Ball bearing assy (front)	1
F 903		MH27E0383	クランククミタテ	Crank assy	1
F 904		MH27E0580	テンピンハリクミタテ	Thread take-up lever assy	1

G デジタルテンション機構
DIGITAL TENSION MECHANISM

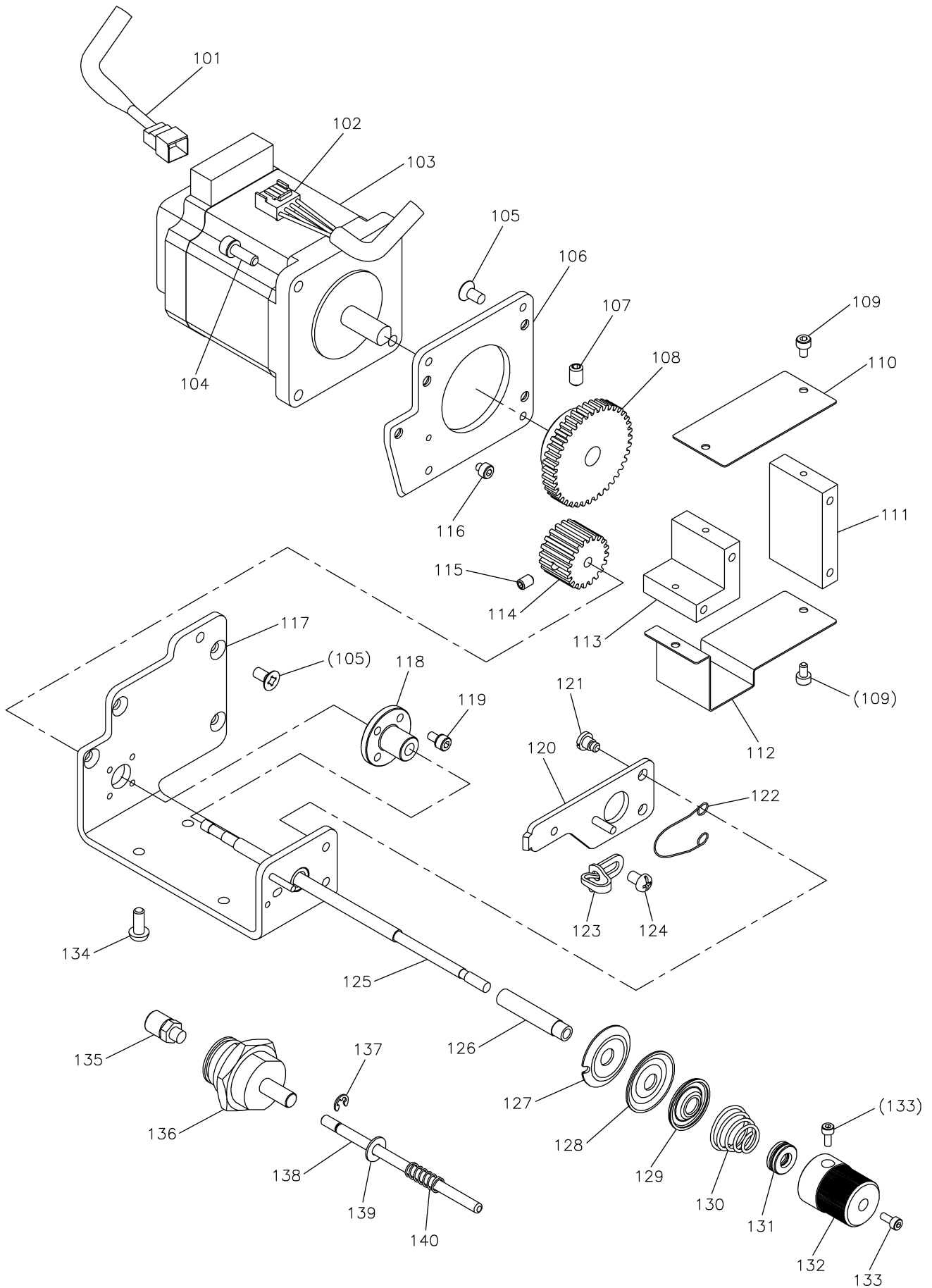

[G] デジタルテンション機構
DIGITAL TENSION MECHANISM

Fig no.	変更 Mod.	部品コード Parts no.	品名	Description	数量 Amt. Req.
G 101		MJ60A7508	ケーブル(PF/DTモータエンコーダ)	Cable (PF/DT moter encoder)	1
G 102		MJ60A6508	ケーブル(PF/DTモータテンゲン)	Cable (PF/DT moter power)	1
G 103		MH13A0848	ステップモータ	Stepping motor	1
☆ G 104		M94007017	セフティソケット M4X12	Safety socket bolt M4X12	4
☆ G 105		M91400010	Pサラネジ M4X8	Countersunk screw M4X8	8
G 106		MJ60A5770	モータベース	Motor base	1
☆ G 107		M95004020	ロッカアナツキトメネジ M5X8	Set screw M5X8	1
G 108		MJ60A1722	ヒラハゲルマ	Gear	1
☆ G 109		M93003021	ロッカアナツキホルト M3X6	Socket bolt M3X6	4
G 110		MJ60A9339	カバーA	Cover A	1
G 111		MJ60A1751	モータブロックA	Motor block A	1
G 112		MJ60B0339	カバーB	Cover B	1
G 113		MJ60A2751	モータブロックB	Motor block B	1
G 114		MJ60A0722	ヒラハゲルマクミタテ	Gear assy	1
☆ G 115		M91053020	ロッカアナツキトメネジ M4X6	Set screw M4X6	1
G 116		M93022021	ロッカアナツキホルト M3X3	Socket bolt M3X3	1
G 117		MJ60A0770	ユニットベースクミタテ	Unit base assy	1
G 118		M92453047	ショウケイオクリネジナット	Feed screw nut	1
G 119		M94003017	セフティソケット M3X6	Safety socket bolt M3X6	4
G 120		MJ60A0220	イトルメイタクミタテ	Tension releasing plate assy	1
G 121		M90902015	ヒラネジダンツキ 9/64(40)X3	Shoulder bolt 9/64(40)X3	2
G 122		MJ60A0851	モトシハネ	Reverse spring	1
G 123		MG43A1181	イトアンナイ	Thread guide	1
☆ G 124		M91011004	フランマイナネジ M4X6	Pan screw M4X6	1
G 125		MJ60A0471	スベリネジ	Slide screw	1
G 126		MJ60A0482	チョウシスリーブ	Thread tension sleep	1
G 127		ML10A0555	チョウシガラ	Thread tension disc	1
☆ G 128		MF10A0555	チョウシガラ	Thread tension disc	1
G 129		MJ60A0556	チョウシガラオサエ	Thread tension releasing disc	1
G 130		MJ60A0245	エンスイハネ φ1.2	Thread tension spring φ1.2	1
G 131		MJ60A4456	スラストタマシクウケ	Thrust ball bearing	1
G 132		MJ60A0573	ツマミ	Thumb nut	1
G 133		M92001021	ロッカアナツキホルト M2.5X6	Socket bolt M2.5X6	2
G 134		M94036021	ロッカアナツキボタンホルト M4X10	Button bolt M4X10	4
G 135		MJ60A0625	ホースニップル	Hose nipple	1
G 136		MJ60A1434	ピンシリンダ	Pin cylinder	1
☆ G 137		M90512065	Eタイプ外ワ 3	E-type retaining ring 3	1
G 138		M90434060	ピン	Pin	1
☆ G 139		M90421050	ミガキサガネ 4	Large washer 4	1
☆ G 140		MH10A2701	ハネ	Spring	1

H 中押え・ワイパー機構
PRESSER BAR LIFTING & WIPER MECHANISM

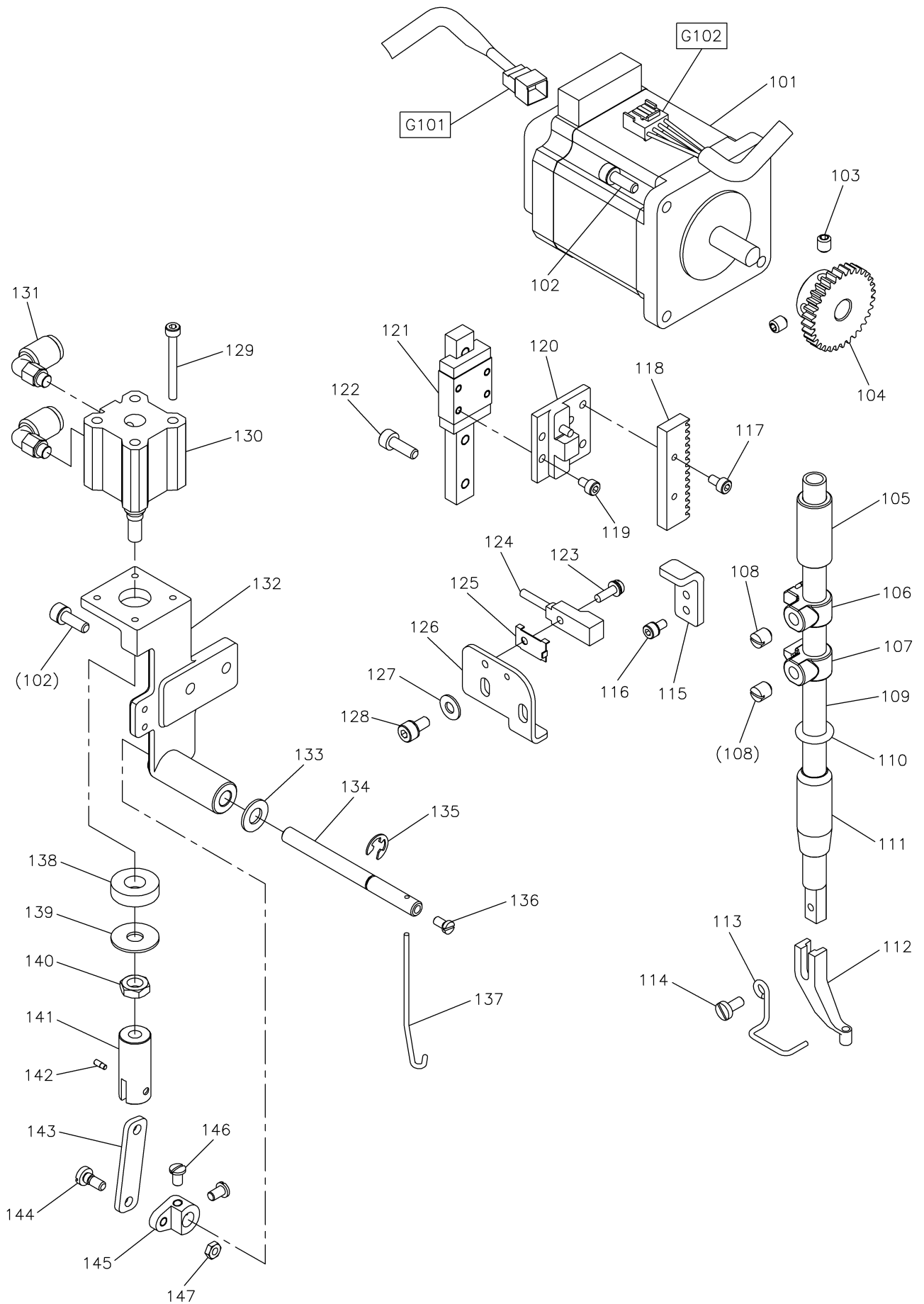

[H] 中押し・ワイパー機構

PRESSER BAR LIFTING & WIPER MECHANISM

Fig no.	変更 Mod.	部品コード Parts no.	品名	Description	数量 Amt. Req.
H 101		MJ60A0848	ステッピングモータ	Stepping motor	1
☆ H 102		M94007017	セフティソケット M4X12	Safety socket bolt M4X12	6
☆ H 103		M94001001	ナイロックトメネジ M5X6	Set screw M5X6	2
H 104		MJ60A2722	ヒラハグルマ	Gear	1
H 105		MJ60A0267	オサエホウメタル ウエ	Presser bar bushing (upper)	1
H 106		MJ60A0751	ナカオサエジョウゲブロック A	Presser bar lifting block A	1
H 107		MJ60A3751	ナカオサエジョウゲブロック B	Presser bar lifting block B	1
☆ H 108		M91506001	トメネジ 15/64(28)X7	Set screw 15/64(28)X7	2
H 109		MJ60A0262	オサエホウ	Presser bar	1
☆ H 110		M90600085	リング	O-ring	1
☆ H 111		MH10A0267	オサエホウメタル シタ	Presser bar bushing (lower)	1
☆ H 112		MV30A0256	オサエ φ3	Presser foot φ3	1
☆ H 113		MH10A0626	ニードルガード	Needle guard	1
☆ H 114		M90922002	ヒラネジ 9/64(40)X8	Flat screw 9/64(40)X8	1
H 115		MJ60A0477	ストップ	Stopper	1
H 116		M94012017	セフティソケット M3X8	Safety socket bolt M3X8	2
☆ H 117		M93002021	ロッカアナツキホルト M3X8	Socket bolt M3X8	2
H 118		MJ60A0901	ラック	Rack	1
☆ H 119		M93003021	ロッカアナツキホルト M3X6	Socket bolt M3X6	4
H 120		MJ60A2770	ナカオサエレンケツベースクミタ	Connecting base assy	1
H 121		MJ60A2920	リニアガイド	Liner motion guide	1
☆ H 122		M94003021	ロッカアナツキホルト M4X12	Socket bolt M4X12	4
H 123		M90971004	SW-PWフライマインベネジ M3X10	SW-PW pan screw M3X10	1
H 124		MJ60A0484	キンセツスイッチ(ナカオサエ)	Detector	1
☆ H 125		MH10A0602	トリツケカナク	Holder	1
H 126		MJ60A5601	ケンシュツキトリツケイタ	Detector bracket	1
☆ H 127		M90421050	ミカキザガネ 4	Large washer 4	2
☆ H 128		M94001017	セフティソケット M4X10	Safety socket bolt M4X10	2
H 129		M93008021	ロッカアナツキホルト M3X30	Socket bolt M3X30	4
H 130		MJ60A2434	エアシリンダ	Air cylinder	1
H 131		MJ60A0422	エルボユニオン	Connector	2
H 132		MJ60A0982	ワイパートリツケイタ	Wiper setting plate	1
☆ H 133		M90631050	ミカキザガネ 6	Large washer 6	1
H 134		MJ60A0983	ワイパーシャフト	Wiper shaft	1
☆ H 135		M90505065	E型外メ 5	E-type retaining ring 5	1
☆ H 136		M90806002	ヒラネジ 1/8(44)X6	Flat screw 1/8(44)X6	1
☆ H 137		MH10A0980	ワイパー	Wiper	1
H 138		M98002052	ウレタンワッシャ	Rubber cushion	1
☆ H 139		M90634050	ザガネ	Washer	1
H 140		M91581045	ロッカナット M6	Nut M6	1
H 141		MJ60A0571	ツギテ	Connector	1
☆ H 142		M90910033	ピンネジ 9/64(40)X4	Screw 9/64(40)X4	1
H 143		MJ60A3910	リンク	Wiper connecting rod	1
☆ H 144		M90932015	ヒラネジダツツキ 9/64(40)X9	Shoulder bolt 9/64(40)X9	1
☆ H 145		MH10A0981	ワイパーウテ	Wiper adapter	1
☆ H 146		M90909003	マルヒラネジ 9/64(40)X6	Flat screw 9/64(40)X6	2
☆ H 147		M90901045	ナット 9/64(40)	Nut 9/64(40)	1

J かま台機構
HOOK SADDLE MECHANISM

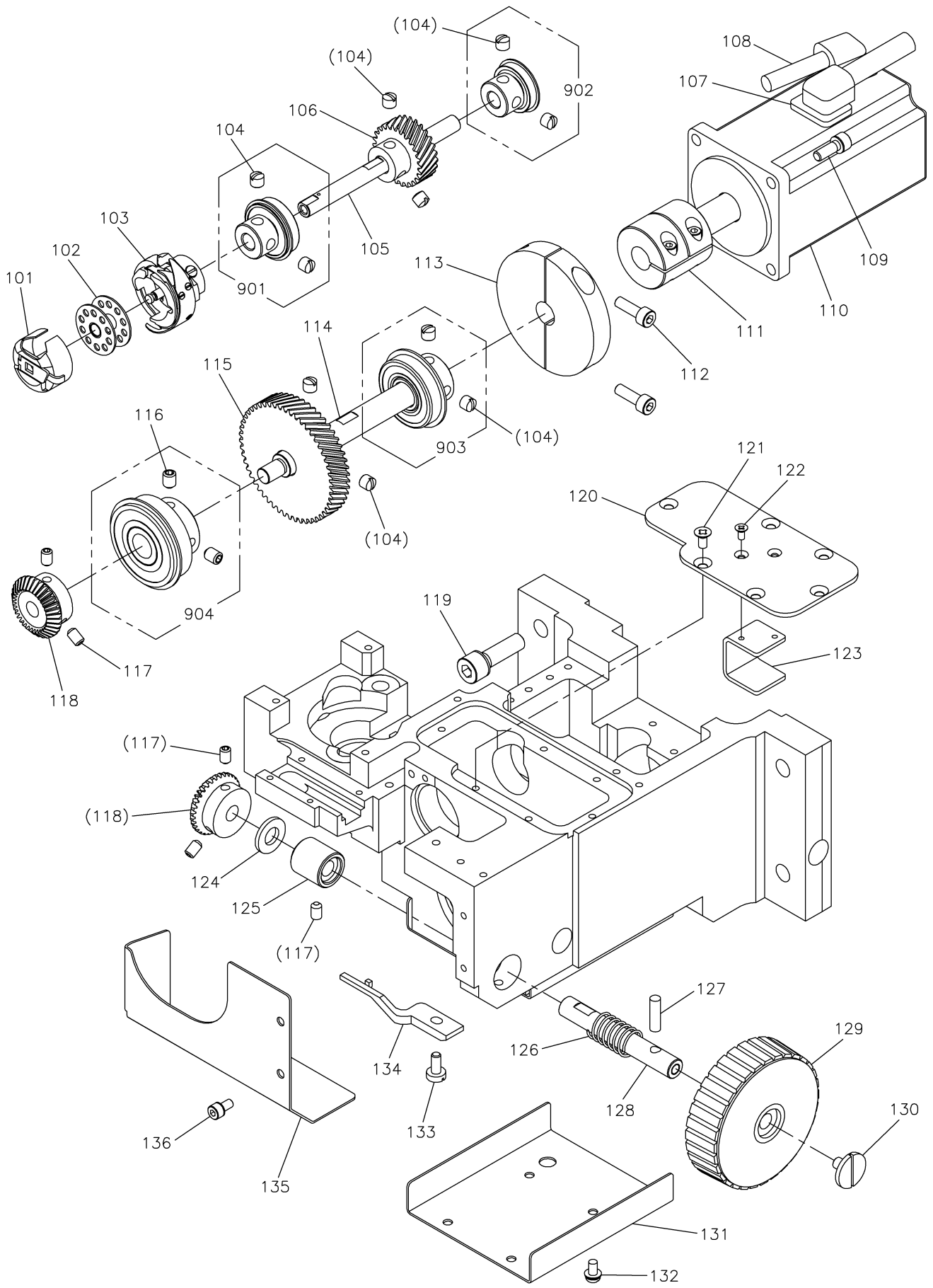

[J]かま台機構

HOOK SADDLE MECHANISM

Fig no.	変更 Mod.	部品コード Parts no.	品名	Description	数量 Amt. Req.
☆ J	101	MG44E0125	ボビンケース	Bobbin case	1
☆ J	102	MF25B0123	ボビン	Bobbin	1
☆ J	103	ME20A0120	カマクミタテ	Hook complete	1
☆ J	104	M91606001	トメネジ 1/4(40)X6	Set screw 1/4(40)X6	10
J	105	MJ60A1450	シタジクヒダリ	Lower shaft (left)	1
☆ J	106	MF13A0683	ハスハハグルマ ショウ	Gear (small)	1
J	107	MJ60B1508	ケーブル(シタジクモータテンゲン)	Cable (lower shaft moter power)	1
J	108	MJ60A1508	ケーブル(シタジクモータエンコーダ)	Cable (lower shaft moter encoder)	1
J	109	M95014017	セフティソケット M5X14	Safety socket bolt M5X14	4
J	110	MJ60A1848	サーボモータ(シタジク)	Servomotor (lower shaft)	1
J	111	MJ60A1364	カップリング	Coupling	1
J	112	M95001021	ロッカアナツキホルト M5X16	Socket bolt M5X16	2
J	113	MJ60A1383	イナーシャ	Inertia rotor	1
J	114	MJ60A0450	シタジクミキ	Lower shaft (right)	1
☆ J	115	MF13A1683	ハスハハグルマ 大	Gear (large)	1
☆ J	116	M91650020	ロッカアナツキトメネジ M6X8	Set screw M6X8	2
☆ J	117	M95004020	ロッカアナツキトメネジ M5X8	Set screw M5X8	5
☆ J	118	MH10A0722	マイタキヤ	Gear	2
J	119	M98002017	セフティソケット M8X30	Safety socket bolt M8X30	4
J	120	MJ60A2742	カマキヤフタ	Hook gear cover	1
☆ J	121	M90449037	Pサラネジ M4X8	Countersunk screw M4X8	6
☆ J	122	M91304010	Pサラネジ M3X6	Countersunk screw M3X6	2
J	123	MJ60A3426	グリスサポータ	Grease supporter	1
☆ J	124	MH10A0416	カンショウゴム	Rubber cushion	1
☆ J	125	MH27A0833	メタル	Bushing	1
☆ J	126	MH10A0572	ツルマキハネ	Spring	1
☆ J	127	M90406064	スプリングピン 4X14	Spring pin φ4X14	1
☆ J	128	MH27A1454	シク	Shaft	1
☆ J	129	MH25A0682	プーリ	Hand pulley	1
☆ J	130	M91119002	ヒラネジ 11/64(40)X6.8	Screw 11/64(40)X6.8	1
J	131	MJ60B1339	ギヤカバー	Gear cover	1
☆ J	132	M91054004	SW-PWプライナベネジ M4X8	Screw M4X8	4
☆ J	133	M91118002	ヒラネジ 11/64(40)X10	Flat screw 11/64(40)X10	1
☆ J	134	MF20A0229	ウチカマトメ	Hook positioner	1
J	135	MJ60A0132	オイルカバー	Oil cover	1
☆ J	136	M94002017	セフティソケット M4X8	Safety socket bolt M4X8	2
J	901	MJ60E3456	ジクウケクミタテ	Ball bearing assy	1
J	902	MJ60E2456	ジクウケクミタテ	Ball bearing assy	1
☆ J	903	MF13E6456	ジクウケクミタテ	Ball bearing assy	1
J	904	MJ60E1456	ジクウケクミタテ	Ball bearing assy	1

K 糸切り機構
THREAD TRIMMING MECHANISM

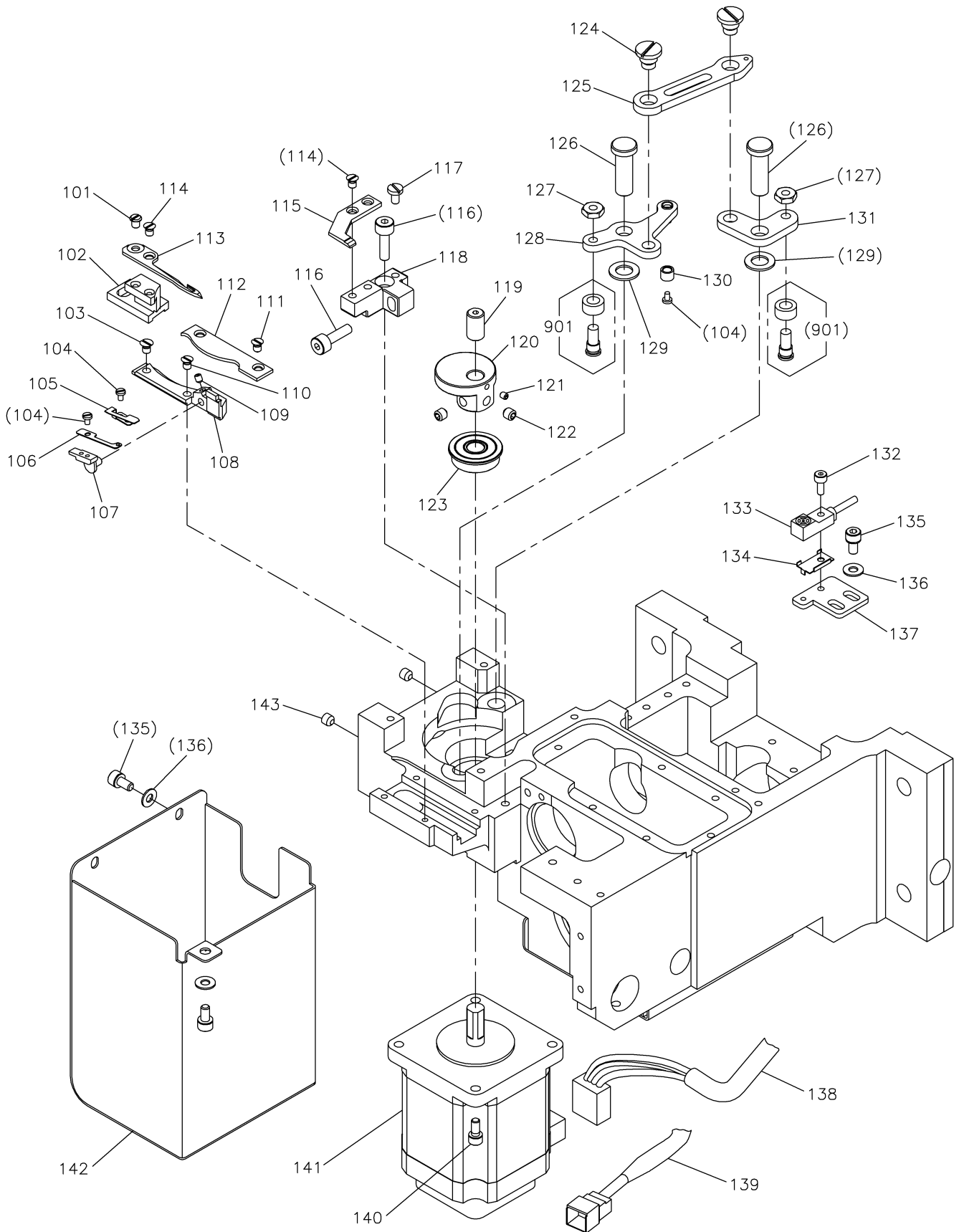

[K]糸切り機構

THREAD TRIMMING MECHANISM

Fig no.	変更 Mod.	部品コード Parts no.	品名	Description	数量 Amt. Req.
K 101		M90944002	ヒラネジ 9/64(40)X4.5	Flat screw 9/64(40)X4.5	1
K 102		MN60A0837	メスダイ ミキ	Knife pad (right)	1
K 103		M90906010	サラネジ 6/64(40)X9.5	Countersunk screw 9/64(40)X9.5	1
K 104		M90605002	ヒラネジ 3/32(56)X3.8	Flat screw 3/32(56)X3.8	4
K 105		MN82A0192	イタバネ	Spring plate	1
K 106		MN82A1192	イタバネ	Spring plate	1
K 107		MN82A0551	チョウセツタイ	Regulator	1
K 108		MN82A1154	アンナイカネ ミキ	Guide (right)	1
K 109		M93003020	ロッカアナツキメネジ M3X3	Set Screw M3X3	1
K 110		M90801010	サラネジ 1/8(44)X10	Countersunk screw 1/8(44)X10	1
K 111		M90903010	サラネジ 9/64(40)X6	Countersunk screw 9/64(40)X6	2
K 112		MN60A2742	フタ(ミキ)	Cover (right)	1
K 113		MJ60A0834	イウメス	Moved knife	1
☆ K 114		M90907010	サラネジ 6/64(40)X5	Countersunk screw 9/64(40)X5	3
K 115		MP41A0838	コテイメス	Fixed knife	1
K 116		M91106022	ボルト 11/64(40)X16	Bolt 11/64(40)X16	2
☆ K 117		M90920002	ヒラネジ 9/64(40)X6.5	Flat screw 9/64(40)X6.5	1
K 118		MJ60A0839	メストリツケダイ	Fixed knife holder	1
K 119		M90807063	ロッカアナツキピン	Hexagon socket head pin	1
K 120		MJ60A0350	イキリカム	Thread trimmer cam	1
☆ K 121		M91057020	ロッカアナツキメネジ M3X4	Set screw M3X4	1
☆ K 122		M95004021	ロッカアナツキメネジ M5X5	Set screw M5X5	2
K 123		M91001075	ジクウケ	Ball bearing	1
☆ K 124		M91690015	ヒラネジダンツキ 1/4(40)X4	Flat screw 1/4(40)X4	2
K 125		MJ60A0910	リンク	Link	1
K 126		M90822060	ピン	Pin	2
☆ K 127		M91201045	ナット 3/16(28)	Nut 3/16 (28)	2
K 128		MJ60A0950	レバー1	Lever 1	1
K 129		M90837050	ワッシャ	Washer	2
K 130		MN60A0411	コロ	Roller	1
K 131		MJ60A1950	レバー2	Lever 2	1
☆ K 132		M93002021	ロッカアナツキボルト M3X8	Socket bolt M3X8	1
K 133		MJ60A1484	キンセツスイッチ(イキリ)	Detector	1
☆ K 134		MH10A0602	トリツケカナグ	Holder	1
☆ K 135		M94002017	セフティソケット M4X8	Safety socket bolt M4X8	5
☆ K 136		M90421050	ミカキザガネ 4	Washer 4	5
K 137		MJ60A7601	ケンシュツキトリツケイタ	Detector bracket	1
K 138		MJ60A4508	ケーブル(イキリモータデンゲン)	Cable (TRIM moter power)	1
K 139		MJ60A5508	ケーブル(イキリモータエンコーダ)	Cable (TRIM moter encoder)	1
☆ K 140		M94007017	セフティソケット M4X12	Safety socket bolt M4X12	4
K 141		MH13A0848	ステッピングモータ	Stepping motor	1
K 142		MJ60A1849	モータカバー	Motor cover	1
☆ K 143		M95004020	ロッカアナツキメネジ M5X8	Set screw M5X8	2
☆ K 901		MF01E0411	コロ・コロシクミタテ	Cam follower. Shoulder screw assy	2

L X-Yテーブル機構
X-Y TABLE MECHANISM

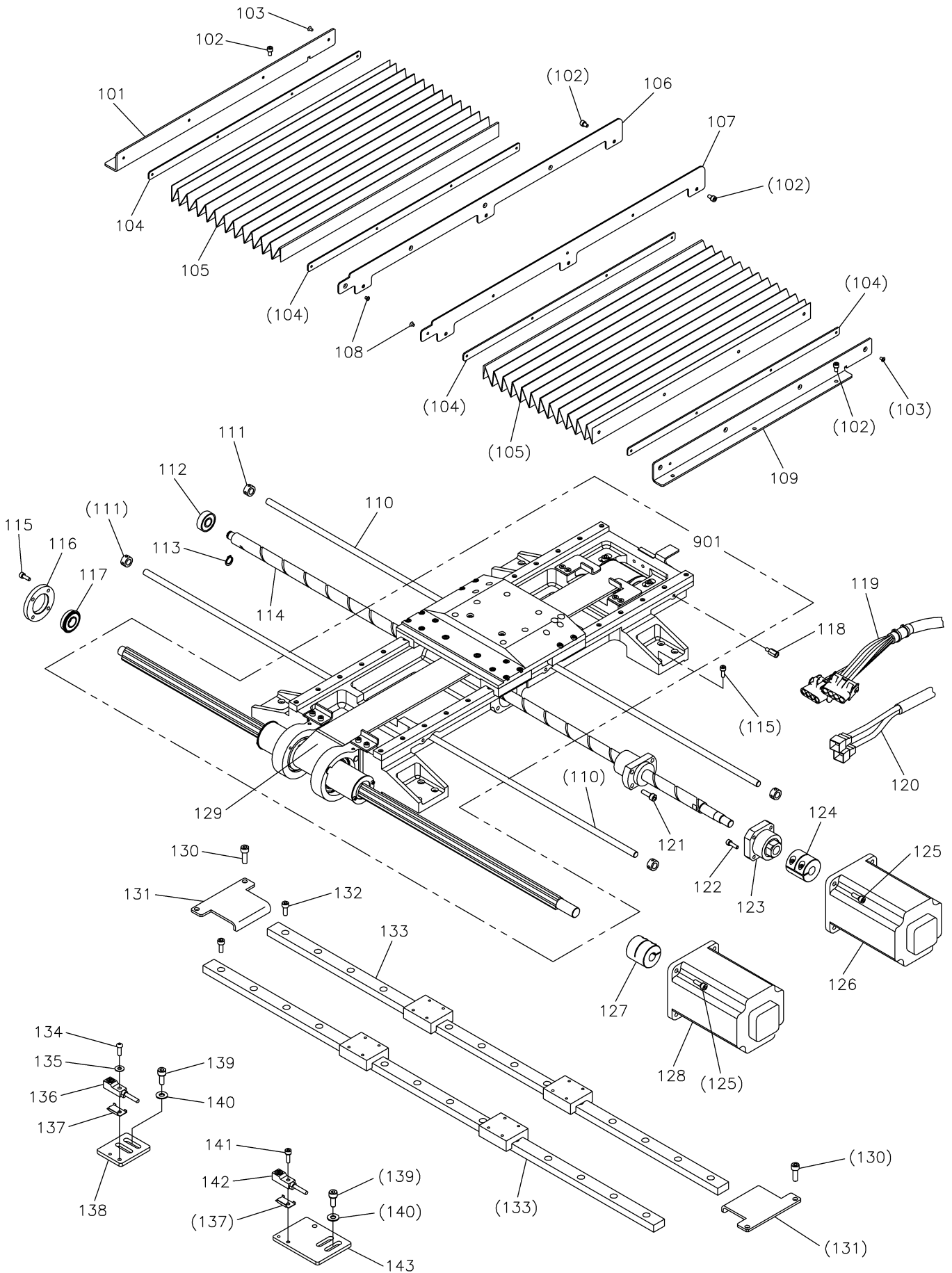

[L]X-Yテーブル機構
X-Y TABLE MECHANISM

Fig no.	変更 Mod.	部品コード Parts no.	品 名	Description	数量 Amt. Req.
L	101	MJ60A1228	シャバラトリツケイタ ヒダリ	Shutter adapter (left)	1
☆ L	102	M94002017	セフティソケット M4X8	Safety socket bolt M4X8	12
L	103	M91304010	フライマサラネジ M3X6	Countersunk screw M3X6	8
L	104	MJ60A0420	シャバラコイタイタ	Shutter fixed plate	4
L	105	MJ60A0458	シャバラ	Shutter	2
L	106	MJ60A1359	ガイドイタ ヒダリ	Guide plate (left)	1
L	107	MJ60A0359	ガイドイタ ミキ	Guide plate (right)	1
L	108	M91305010	フライマサラネジ M3X4	Countersunk screw M3X4	8
L	109	MJ60A0228	シャバラトリツケイタ ミキ	Shutter adapter (right)	1
L	110	MJ60A2454	シャフト	Shaft	2
☆ L	111	MJ60A0352	セットカラー	Set collar	4
☆ L	112	MS02A2456	ジクウケ	Ball bearing	1
L	113	M90516065	Cカ外メワ 10	C-type retaining ring 10	1
L	114	MJ60A0786	ボールネジ	Ball screw	1
☆ L	115	M94007017	セフティソケット M4X12	Safety socket bolt M4X12	20
L	116	MJ60A4780	ベアリングホルダ	Bearing holder	1
☆ L	117	MH40A0456	ジクウケ	Ball bearing	1
L	118	MJ60A5476	スペーサ	Spacer	6
L	119	MJ60B4508	ケーブル(XYモータテンゲン)	Cable (XY moter power)	1
L	120	MJ60B5508	ケーブル(XYモータエンコーダ)	Cable (XY moter encoder)	1
☆ L	121	M95001017	セフティソケット M5X20	Safety socket bolt M5X20	4
☆ L	122	M94019017	セフティソケット M4X14	Safety socket bolt M4X14	4
L	123	MJ60A4426	サポートユニット	Support unit	1
L	124	MJ60A2364	カップリング	Coupling	1
☆ L	125	M95004017	セフティソケット M5X16	Safety socket bolt M5X16	8
L	126	MJ60C1508	ステッピングモータ X	Stepping motor X	1
L	127	MJ60A1364	カップリング	Coupling	1
L	128	MJ60C2508	ステッピングモータ Y	Stepping motor Y	1
L	129	MJ60A0523	タイミングベルト	Timing belt	1
☆ L	130	M96002017	セフティソケット M6X12	Safety socket bolt M6X12	4
L	131	MJ40A0477	Xストッパ	X stopper	2
☆ L	132	M95003021	ロッカアナツキホルト M5X12	Socket bolt M5X12	28
L	133	MJ60A0920	リニアガイド	Liner motion guide	2
☆ L	134	M91606022	ロッカアナツキホルタンホルト M3X10	Button bolt M3X10	1
☆ L	135	M90316050	ミカキザガネ 3	Large washer 3	1
L	136	MJ60A2484	キンセツスイッチ(Xジク)	Detector X	1
☆ L	137	MH10A0602	トリツケカナグ	Holder	2
L	138	MJ40A0601	Xケンシュツキトリツケイタ	X detector bracket	1
☆ L	139	M94001017	セフティソケット M4X10	Safety socket bolt M4X10	4
☆ L	140	M90421050	ミカキザガネ 4	Large washer 4	4
☆ L	141	M93002021	ロッカアナツキホルト M3X8	Socket bolt M3X8	1
L	142	MJ60A3484	キンセツスイッチ(Yジク)	Detector Y	1
L	143	MJ40A1601	Yケンシュツキトリツケイタ	Y detector bracket	1
L	901	MJ40E0747	ドライブフレームクミタテ	Drive frame assy	1

M チャッキング装置
JIG EJECT SYSTEM

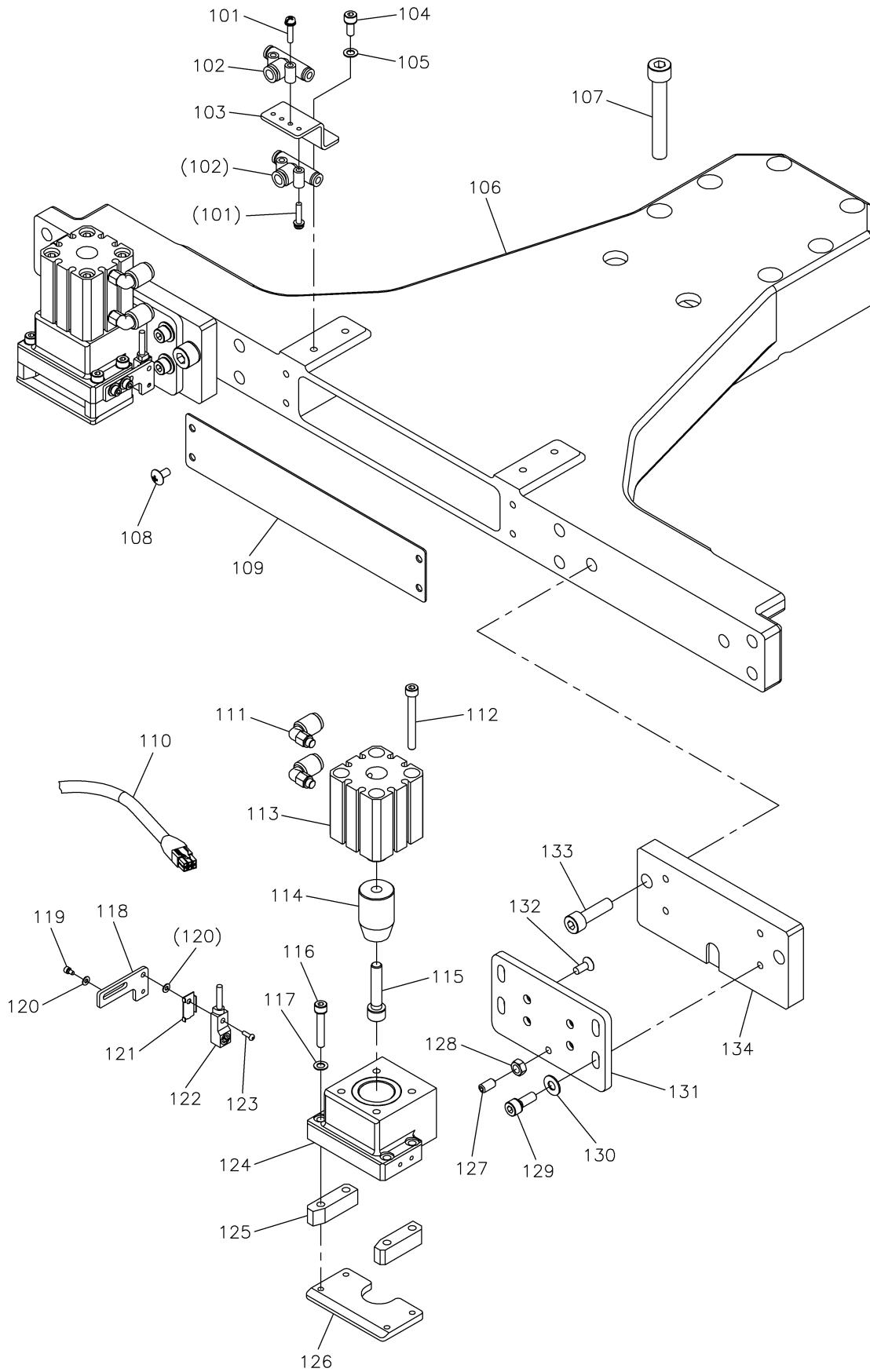

[M]チャッキング装置
JIG EJECT SYSTEM

Fig Mo.	変更 Mod.	部品コード Parts no.	品名	Description	数量 Amt. Req.
☆ M	101	M90864004	SW-PW ^ラ マイナ ^ベ ネジ M3X14	SW-PW pan screw M3X14	4
☆ M	102	MJ60A3571	クダツギ ^テ	T-type quick joint	2
☆ M	103	MJ60A1420	ツギ ^テ コテイ ^イ タ	Air fitting bracket	1
☆ M	104	M94007017	セフ ^テ イソ ^ケ ット M4X12	Safety socket bolt M4X12	1
☆ M	105	M90421050	ミカ ^キ ザ ^ガ ネ 4	Large washer 4	1
M	106	MJ60A5747	オサ ^エ フ ^レ ーム	Clamp frame	1
M	107	M98003021	ロツ ^カ ク ^ア ナツ ^キ ホ ^ル ト M8X55	Socket bolt M8X55	6
☆ M	108	M94001036	トラス ^ネ ジ M4X8	Truss screw M4X8	4
M	109	MJ60A3742	フ ^タ	Cover	1
M	110	MJ60B2508	ケ ^ー ブル ⁽ チャ ^ク キ ^ン グ ^セ ン ^サ ⁾	Cable (jig eject sensor)	1
M	111	MB61A1571	エル ^ホ ユ ^ニ オン	Connector	4
M	112	M95035021	ロツ ^カ ク ^ア ナツ ^キ ホ ^ル ト M5X45	Socket bolt M5X45	8
M	113	MJ60A3434	ウ ^ス カ ^タ シ ^リ ン ^ダ	Air cylinder	2
M	114	MJ60A0755	テ ^ー パ ^ー フ ^ッ シ ^ャ	Taper pusher	2
M	115	M96007017	セフ ^テ イソ ^ケ ット M6X30	Safety socket bolt M6X30	2
M	116	M94025017	セフ ^テ イソ ^ケ ット M4X25	Safety socket bolt M4X25	8
☆ M	117	M90422050	コ ^ザ ガ ^ネ 4	Small washer 4	8
M	118	MJ60A4601	セン ^サ トリ ^ツ ケ ^イ タ	Detector bracket	2
M	119	M94012017	セフ ^テ イソ ^ケ ット M3X8	Safety socket bolt M3X8	4
☆ M	120	M90316050	ミカ ^キ ザ ^ガ ネ 3	Large washer 3	6
☆ M	121	MH10A0602	トリ ^ツ ケ ^カ ナ ^グ	Holder	2
M	122	MJ60A4484	キン ^セ ツ ^ス イ ^ッ チ ⁽ チャ ^ク キ ^ン グ ⁾	Detector	2
☆ M	123	M91606022	ロツ ^カ ク ^ア ナツ ^キ ホ ^ル ト ^タ ン ^ホ ル ^ト M3X10	Button bolt M3X10	2
M	124	MJ60E1747	ジ ^グ フ ^レ ーム ^ク ミ ^タ テ	Jig eject flame assy	2
M	125	MJ60A2359	サイ ^ト ガ ^イ ト	Side guide	4
M	126	MJ60A3359	アン ^ダ ー ^ガ イ ^ト	Under guide	2
M	127	M95001020	ロツ ^カ ク ^ア ナツ ^キ ト ^メ ネ ^ジ M5X10	Set screw M5X10	2
M	128	M91382045	ナ ^{ット} M5	Nut M5	2
M	129	M95014017	セフ ^テ イソ ^ケ ット M5X14	Safety socket bolt M5X14	8
☆ M	130	M90511050	ミカ ^キ ザ ^ガ ネ 5	Large washer 5	8
M	131	MJ60A4770	ジ ^グ ベ ^ー ス	Jig eject base	2
M	132	M91500010	P ^サ ラ ^ネ ジ M5X12	Countersunk screw M5X12	8
☆ M	133	M98001017	セフ ^テ イソ ^ケ ット M8X25	Safety socket bolt M8X25	4
M	134	MJ60A0476	ス ^ペ ー ^サ	Spacer	2

N 配線・配管関係
CABLE COMPONENT & PNEUMATIC CONTROL UNIT

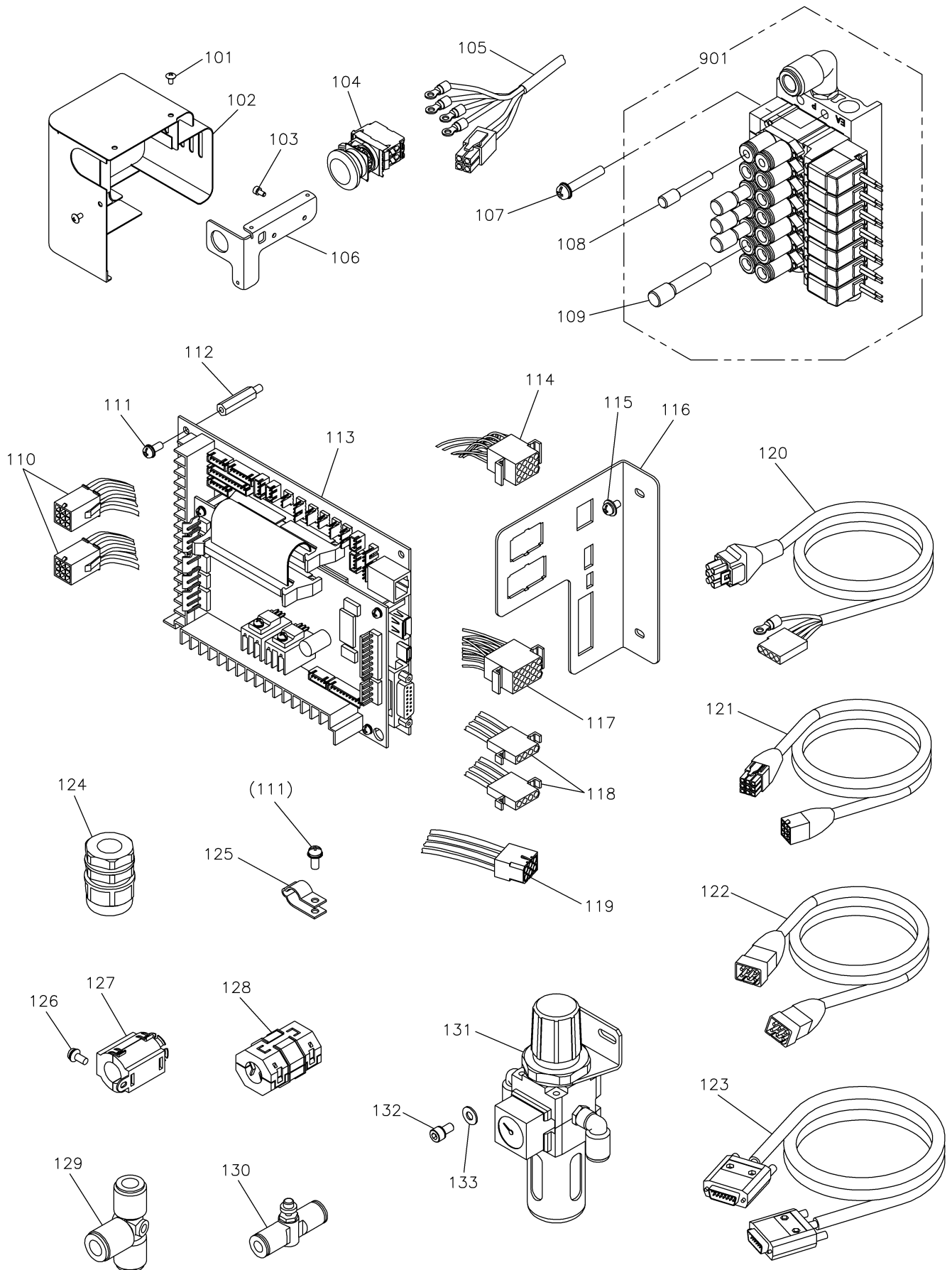

[N] 配線・配管関係

CABLE COMPONENT & PNEUMATIC CONTROL UNIT

Fig no.	変更 Mod.	部品コード Parts no.	品名	Description	数量 Amt. Req.
☆ N 101		M94001036	トラスネジ M4X8	Truss screw M4X8	3
N 102		MJ60B5339	トウカバー	Head cover	1
☆ N 103		M94002017	セフティソケット M4X8	Safety socket bolt M4X8	2
N 104		MJ60A5484	トチュウテイスイツチ	Stop switch	1
N 105		MJ60B0508	ケーブル(トチュウテイシ/PFセンサ)	Cable (stop switch/PF sensor)	1
N 106		MJ60A9601	スイッチトリツケイタ	Stop switch bracket	1
N 107		M91066004	SW-PWプラマイナネジ M4X25	SW-PW pan screw M4X25	4
N 108		MA30A0757	プラグ	Plug	1
N 109		MB62A0757	プラグ	Plug	4
N 110		MJ60B9508	ケーブル(フカンクモータエンコーダ)	Cable (DT/TRIM moter encoder)	1
☆ N 111		K14S90203410	SW-PW Pナネジ M4X10	SW-PW pan screw M4X10	11
N 112		MJ60A3476	スペーサボルト	Spacer bolt	4
N 113		M800J2MIF	MIFキバン PLK-J2-MIF	Print circuit board PLK-J2-MIF	1
N 114		MJ60B6508	ケーブル(MIFニューリヨク)	Cable (MIF input)	1
☆ N 115		M91071004	SW-MWプラマイナネジ M4X8	SW-MW pan screw M4X8	2
N 116		MJ60A3601	MIFコネクタトリツケイタ	MIF connector bracket	1
N 117		MJ60B7508	ケーブル(MIFシュツリヨク)	Cable (MIF output)	1
N 118		MJ60B8508	ケーブル(フカンクモータデンゲン)	Cable (DT/TRIM moter power)	1
N 119		MJ60C0508	ケーブル(MIFデンゲン)	Cable (MIF power)	1
N 120		MJ60A2508	ケーブル(PFモータデンゲン)	Cable (PF moter power)	1
N 121		MJ60A3508	ケーブル(PFモータエンコーダ)	Cable (PF moter encoder)	1
N 122		MJ60B3508	ケーブル(MIFキバンデンゲン)	Cable (MIF power)	1
☆ N 123		M97320099	ケーブル(MIFキバンシンゴウ)	Cable (MIF signal pulse)	1
N 124		MB60A5780	ケーブルグラント	Cable gland	3
☆ N 125		MB60A0620	ナイロンクリップ FG	Nylon clip FG	5
☆ N 126		M91056004	SW-PWプラマイナネジ M4X10	SW-PW pan screw M4X10	4
☆ N 127		K14M19400102	フェライトコア	Ferritic core	5
N 128		MJ60A0413	フェライトコア	Ferritic core	1
N 129		MJ60A1571	チース	T-shape connector	1
N 130		MH60T0497	スピードコントローラ	Speed controller	2
☆ N 131		MJ41A0963	フィルタレギュレータ	Filter regulator	1
☆ N 132		M95003017	セフティソケット M5X8	Safety socket bolt M5X8	2
☆ N 133		M90511050	ミカキサガネ 5	Large washer 5	2
N 901		MJ60E0599	デンジベンクミタテ	Solenoid valve complete	1

P 給油機構
OIL LUBRICATION MECHANISM

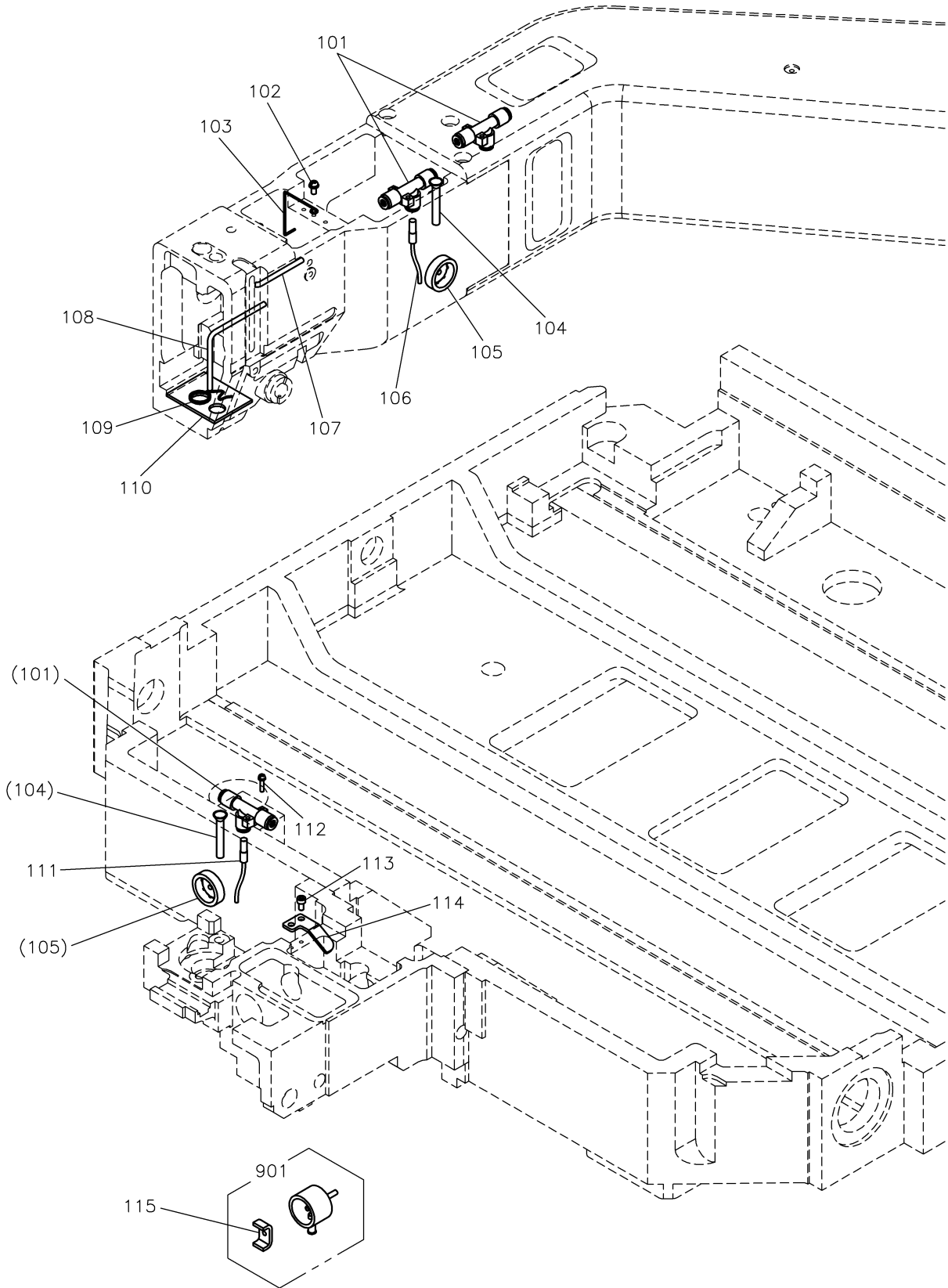

[P]給油機構

OIL LUBRICATION MECHANISM

Fig no.	変更 Mod.	部品コード Parts no.	品 名	Description	数量 Amt. Req.
P 101		MJ60A2571	シクウエジクタ	Vacuum ejector	3
☆ P 102		M91056004	SW-PWプライナベネジ M4X10	SW-PW pan screw M4X10	1
P 103		ME20A2780	ホルダ	Holder	1
☆ P 104		MA20A6688	パイプ 43L	Pipe 43L	2
☆ P 105		MN10A0135	アブラマト	Oil gauge	2
P 106		MJ60E0688	キュウユパイプクミタテ	Filler pipe assy	1
P 107		MJ60A0688	オイルパイプ A	Oil pipe A	1
P 108		MJ60A1688	オイルパイプ B	Oil pipe B	1
☆ P 109		MF00A2780	ホルダ	Holder	1
P 110		MJ60A0740	フェルト	Felt	1
P 111		MJ60E1688	キュウユパイプクミタテ	Filler pipe assy	1
☆ P 112		M90864004	SW-PWプライナベネジ M3X14	SW-PW pan screw M3X14	2
☆ P 113		M95018021	ロッカアナツキホルト M4X8	Socket bolt M4X8	2
P 114		MJ60A0257	キュウユキャップオサエ	Filler cap presser plate	1
P 115		MJ60A1740	フェルト	Felt	1
P 901		MJ60E0366	キュウユキャップクミタテ	Filler cap assy	1

Q テーブル関係
TABLE & STAND

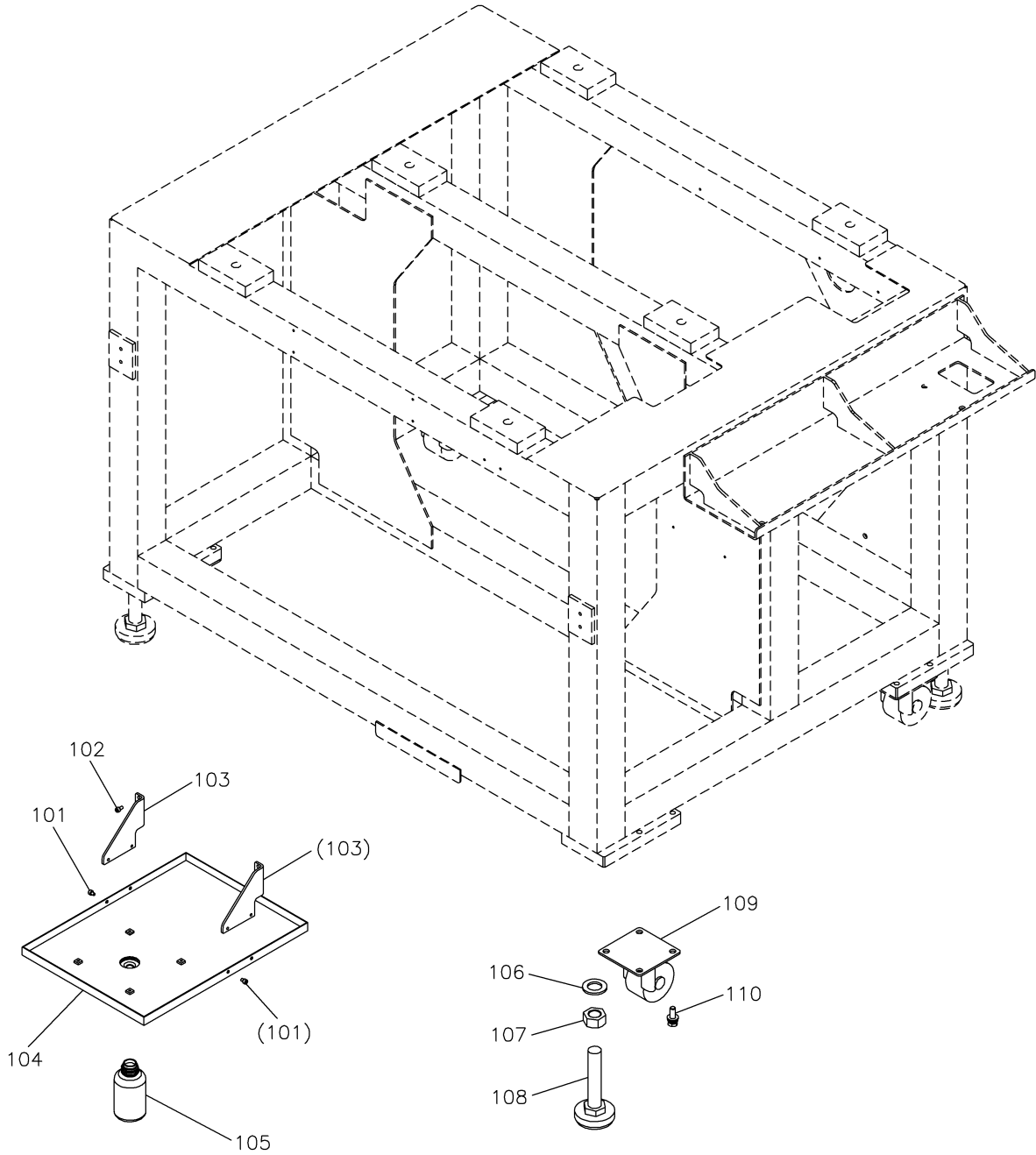

[Q]テーブル関係
TABLE & STAND

Fig no.	変更 Mod.	部品コード Parts no.	品 名	Description	数量 Amt. Req.
☆ Q 101		M94008017	セフティソケット M4X6	Safety socket bolt M4X6	4
☆ Q 102		M94002017	セフティソケット M4X8	Safety socket bolt M4X8	4
Q 103		MJ60A5426	オイルパンササエ	Oil pan bracket	2
Q 104		MJ60A0131	アブラウケクミタテ	Oil pan assy	1
☆ Q 105		MF20A0130	アブラビン	Oil bottle	1
☆ Q 106		M92002050	ワッシャ 20	Washer 20	4
☆ Q 107		M95021045	ナット M20	Nut M20	4
☆ Q 108		MA35A0166	アジャスタフット	Ajustor foot	4
☆ Q 109		ME40A0368	キャスター	Castor	4
☆ Q 110		M92058022	SW-PWロッカケボルト M8X25	SW-PW hexagon bolt M8X25	16

R 付属品
ACCESSORIES

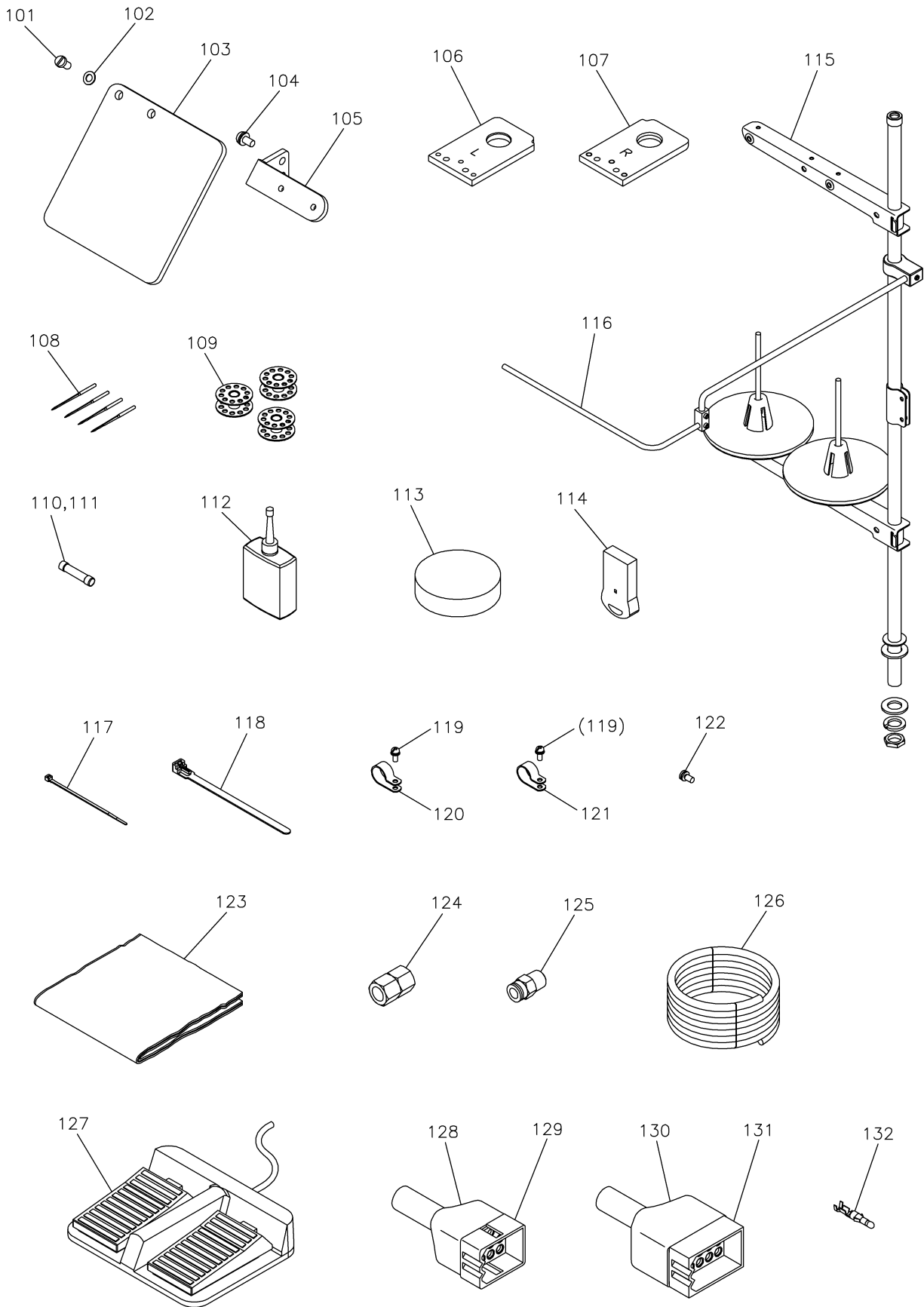

[R] 付属品
ACCESSORIES

Fig no.	変更 Mod.	部品コード Parts no.	品名	Description	数量 Amt. Req.
☆ R 101		M90806002	ヒラネジ 1/8(44)X6	Flat screw 1/8(44)X6	2
☆ R 102		M90317050	コザガネ 3	Small washer 3	2
☆ R 103		MH10A0160	アイガード	Eye guard	1
☆ R 104		M90859004	SW-PWプラマイナヘネジ M3X6	SW-PW pan screw M3X6	2
R 105		MJ60B0601	アイガードトリツケイタ	Eye guard bracket	1
R 106		MJ60A2780	ホルダ(L)	Jig eject holder (left)	1
R 107		MJ60A3780	ホルダ(R)	Jig eject holder (right)	1
☆ R 108		MS02A0128	ミシンハリ DPX17#18	Needle DPX17#18	4
☆ R 109		MF25B0123	ホビン	Bobbin	3
☆ R 110		K14M46000158	ヒューズ 2.5A	Fuse 2.5A	1
☆ R 111		K14M46000159	ヒューズ 20A	Fuse 20A	1
☆ R 112		MF10A0149	アブラサシ	Oiler	1
R 113		MJ60A1419	ホウシゴム	Rubber cushion	4
R 114		MJ61E1991	USBメモリ	USB memory	1
☆ R 115		MH10E0193	イトタテダイヤセット	Cotton stand assy	1
R 116		ME35E0180	イトアンナイクミタテ	Thread guide assy	1
☆ R 117		MF06A1620	ケツクバンド L=100	Cable tie L=100	1
☆ R 118		MB60A0201	ケツクバンド L=140	Cable tie L=140	3
☆ R 119		M91056004	SW-PWプラマイナヘネジ M4X10	SW-PW pan screw M4X10	2
☆ R 120		MB60A2620	ナイロンクリップ 10N	Nylon clip 10N	1
☆ R 121		MB60A1620	ナイロンクリップ 8N	Nylon clip 8N	1
☆ R 122		K14S90203410	SW-PW Pナヘネジ M4X10	Screw M4X10	1
☆ R 123		MJ60A0734	ビニールカバー	Polyethylene cover	1
☆ R 124		M91010089	ロッカクソケット	Socket	1
☆ R 125		MA30A0571	ワンタッチツギテ	Quickjoint	1
☆ R 126		MS06A0567	ウレタンチューブ	Air tube	1
☆ R 127		MH10A0FSW	フットスイッチ	Foot switch	1
R 128		K14M96821809	ナイロンキャップ 12P	Nylon cap 12P	1
R 129		K14M94319012	コネクタ 12P	Connector 12P	1
R 130		K14M96822602	ナイロンキャップ 15P	Nylon cap 15P	1
R 131		K14M94319015	コネクタ 15P	Connector 15P	1
R 132		K14M77014710	ターミナル	Terminal	30

S オプションパーツ
OPTION PARTS

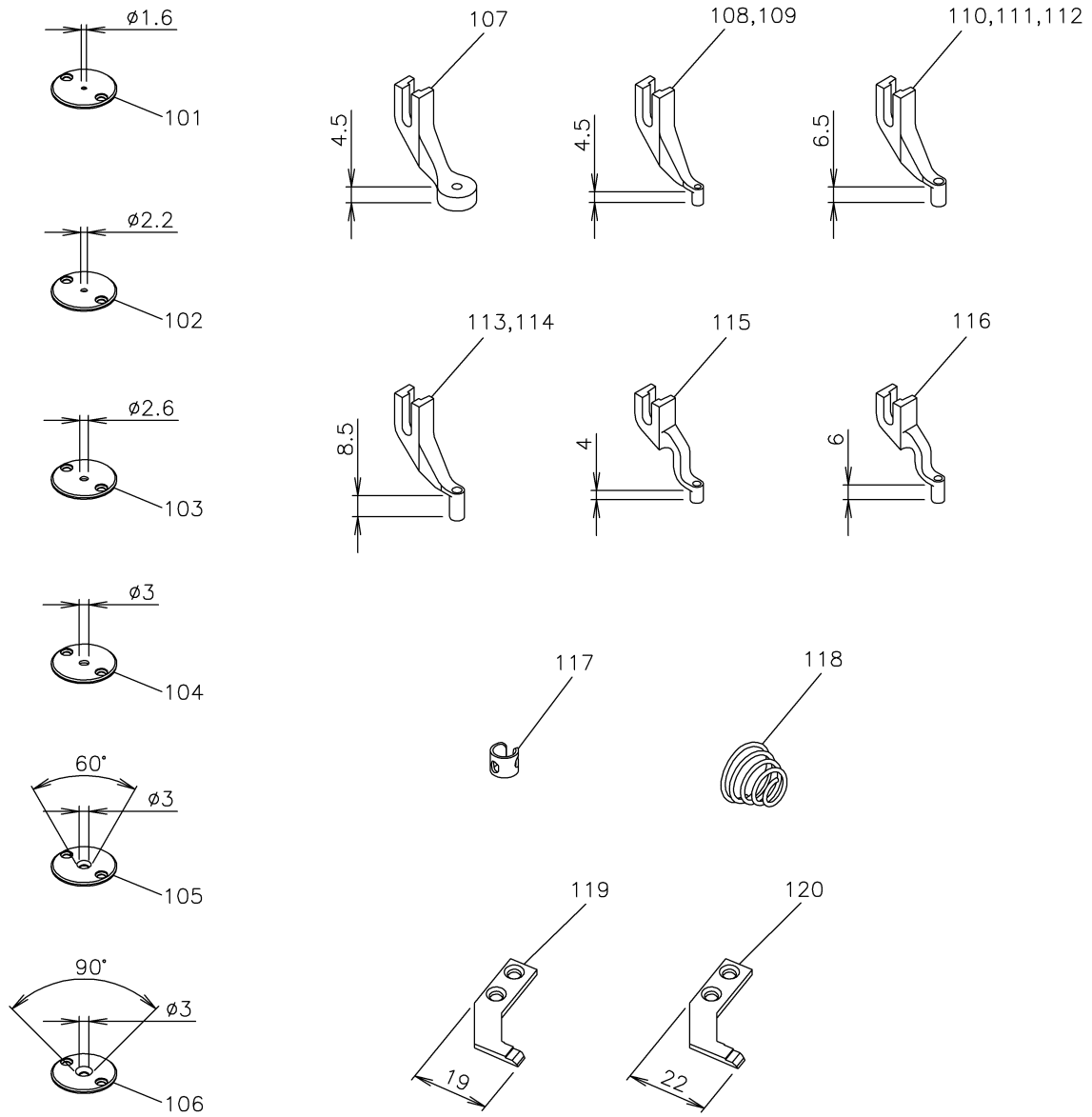

[S]オプションパーツ
OPTION PARTS

Fig no.	変更 Mod.	部品コード Parts no.	品名	Description	数量 Amt. Req.
☆ S 101		MS02A0101	ハリイタ φ1.6	Needle plate φ1.6	1
☆ S 102		MS02A1101	ハリイタ φ2.2 (ヒョウジユン)	Needle plate φ2.2 (standard)	1
☆ S 103		MS02A2101	ハリイタ φ2.6	Needle plate φ2.6	1
☆ S 104		MH51A0101	ハリイタ φ3	Needle plate φ3	1
☆ S 105		MH51A1101	ハリイタ φ3 (60° テーパ)	Needle plate φ3 (60° taper)	1
☆ S 106		MH51A2101	ハリイタ φ3 (90° テーパ)	Needle plate φ3 (90° taper)	1
☆ S 107		MV35A0106	サラオサエ φ3	Presser foot φ3	1
☆ S 108		MV30A0256	ナカオサエ φ3 (ヒョウジユン)	Presser foot φ3 (standard)	1
☆ S 109		MV30A1256	ナカオサエ φ2	Presser foot φ2	1
☆ S 110		MB10M0256	ナカオサエ φ3.3	Presser foot φ3.3	1
☆ S 111		MS03A0256	ナカオサエ φ3	Presser foot φ3	1
☆ S 112		MS03A1256	ナカオサエ φ2	Presser foot φ2	1
☆ S 113		MA35A0256	ナカオサエ φ3	Presser foot φ3	1
☆ S 114		MA35A1256	ナカオサエ φ2	Presser foot φ2	1
☆ S 115		MA21A0256	ナカオサエ φ2.5	Presser foot φ2.5	1
☆ S 116		MA21A1256	ナカオサエ φ2.5	Presser foot φ2.5	1
☆ S 117		MG42A0181	イトアンナイ (アツモ/ヨウ)	Thread guide (for heavy)	1
S 118		MJ60A1245	エンスイハネ φ1.6	Thread tension spring φ1.6	1
S 119		MP41A0838	コテイメス (ヒョウジユン)	Fixed knife (standard)	1
S 120		MP69A0838	コテイメス (シタイトサンリョウタンシュク)	Fixed knife (*1)	1

*1: for bobbin thread remaining amount reduction

索引
INDEX-1

部品コード Parts No.	ページ Page	Fig No.	部品コード Parts No.	ページ Page	Fig No.	部品コード Parts No.	ページ Page	Fig No.	部品コード Parts No.	ページ Page	Fig No.
K14M19400102	*** P25	*** N 127	M90825050	*** P3	*** B 109	M91382045	*** P23	*** M 128	M94007017	*** P23	*** M 104
K14M46000158	*** P31	*** R 110	M90836050	*** P11	*** F 126	M91384045	*** P7	*** D 106	M94008017	*** P3	*** B 107
K14M46000159	*** P31	*** R 111	M90837050	*** P19	*** K 129	M91400010	*** P13	*** G 105	↑	*** P29	*** Q 101
K14M77014710	*** P31	*** R 132	M90858004	*** P9	*** E 105	M91500010	*** P23	*** M 132	M94012017	*** P15	*** H 116
K14M94319012	*** P31	*** R 129	M90859004	*** P9	*** E 120	M91506001	*** P15	*** H 108	↑	*** P23	*** M 119
K14M94319015	*** P31	*** R 131	↑	*** P31	*** R 104	M91581045	*** P15	*** H 140	M94019017	*** P21	*** L 122
K14M96821809	*** P31	*** R 128	M90864004	*** P23	*** M 101	M91602001	*** P11	*** F 125	M94025017	*** P23	*** M 116
K14M96822602	*** P31	*** R 130	↑	*** P27	*** P 112	M91603046	*** P9	*** E 150	M94036021	*** P13	*** G 134
K14S90203410	*** P3	*** B 128	M90883080	*** P9	*** E 133	M91606001	*** P11	*** F 124	M95001017	*** P21	*** L 121
↑	*** P25	*** N 111	M90901045	*** P15	*** H 147	↑	*** P17	*** J 104	M95001020	*** P23	*** M 127
↑	*** P31	*** R 122	M90902015	*** P13	*** G 121	M91606022	*** P21	*** L 134	M95001021	*** P17	*** J 112
M800J2MIF	*** P25	*** N 113	M90903010	*** P19	*** K 111	↑	*** P23	*** M 123	M95001036	*** P3	*** B 102
M90302036	*** P7	*** D 127	M90906010	*** P19	*** K 103	M91650020	*** P11	*** F 121	M95002017	*** P5	*** C 112
M90316050	*** P21	*** L 135	M90907010	*** P9	*** E 147	↑	*** P17	*** J 116	M95002020	*** P11	*** F 110
↑	*** P23	*** M 120	↑	*** P19	*** K 114	M91690015	*** P19	*** K 124	M95003017	*** P7	*** D 136
M90317050	*** P31	*** R 102	M90909003	*** P15	*** H 146	M91802006	*** P11	*** F 123	↑	*** P25	*** N 132
M90406064	*** P11	*** F 103	M90910033	*** P15	*** H 142	M91910080	*** P9	*** E 132	M95003021	*** P3	*** B 124
↑	*** P17	*** J 127	M90920002	*** P9	*** E 145	M92000010	*** P9	*** E 106	↑	*** P9	*** E 131
M90421050	*** P3	*** B 145	↑	*** P19	*** K 117	M92001021	*** P13	*** G 133	↑	*** P21	*** L 132
↑	*** P5	*** C 122	M90922002	*** P15	*** H 114	M92002050	*** P29	*** Q 106	M95004017	*** P21	*** L 125
↑	*** P7	*** D 120	M90932015	*** P15	*** H 144	M92004020	*** P9	*** E 112	M95004020	*** P11	*** F 107
↑	*** P13	*** G 139	M90944002	*** P19	*** K 101	M92058022	*** P29	*** Q 110	↑	*** P13	*** G 107
↑	*** P15	*** H 127	M90971004	*** P15	*** H 123	M92453047	*** P13	*** G 118	↑	*** P17	*** J 117
↑	*** P19	*** K 136	M90990002	*** P5	*** C 101	M93000022	*** P9	*** E 118	↑	*** P19	*** K 143
↑	*** P21	*** L 140	↑	*** P11	*** F 129	M93002021	*** P15	*** H 117	M95004021	*** P19	*** K 122
↑	*** P23	*** M 105	M90991002	*** P3	*** B 140	↑	*** P19	*** K 132	M95005017	*** P5	*** C 107
M90422050	*** P3	*** B 113	M91001075	*** P19	*** K 123	↑	*** P21	*** L 141	↑	*** P7	*** D 114
↑	*** P23	*** M 117	M91007045	*** P3	*** B 114	M93003020	*** P19	*** K 109	M95009021	*** P3	*** B 132
M90434060	*** P13	*** G 138	M91010089	*** P31	*** R 124	M93003021	*** P13	*** G 109	M95014017	*** P17	*** J 109
M90449037	*** P3	*** B 137	M91011004	*** P9	*** E 138	↑	*** P15	*** H 119	↑	*** P23	*** M 129
↑	*** P7	*** D 101	↑	*** P13	*** G 124	M93008021	*** P15	*** H 129	M95018021	*** P27	*** P 113
↑	*** P17	*** J 121	M91051020	*** P9	*** E 139	M93022021	*** P13	*** G 116	M95021045	*** P29	*** Q 107
M90500085	*** P11	*** F 133	M91053020	*** P9	*** E 130	M94001001	*** P15	*** H 103	M95025045	*** P3	*** B 123
M90505065	*** P15	*** H 135	↑	*** P11	*** F 112	M94001017	*** P5	*** C 111	M95035021	*** P23	*** M 112
M90511050	*** P5	*** C 108	↑	*** P13	*** G 115	↑	*** P15	*** H 128	M95053021	*** P3	*** B 115
↑	*** P7	*** D 115	M91054004	*** P17	*** J 132	↑	*** P21	*** L 139	M96001017	*** P11	*** F 117
↑	*** P23	*** M 130	M91056004	*** P25	*** N 126	M94001021	*** P7	*** D 112	M96002017	*** P21	*** L 130
↑	*** P25	*** N 133	↑	*** P27	*** P 102	M94001036	*** P3	*** B 106	M96007017	*** P23	*** M 115
M90512065	*** P13	*** G 137	↑	*** P31	*** R 119	↑	*** P9	*** E 135	M96008017	*** P7	*** D 128
M90516065	*** P21	*** L 113	M91057020	*** P19	*** K 121	↑	*** P23	*** M 108	M97320099	*** P25	*** N 123
M90522037	*** P7	*** D 102	M91066004	*** P25	*** N 107	↑	*** P25	*** N 101	M98001017	*** P23	*** M 133
M90522050	*** P7	*** D 105	M91071004	*** P3	*** B 120	M94002017	*** P3	*** B 146	M98002017	*** P17	*** J 119
M90600085	*** P15	*** H 110	↑	*** P25	*** N 115	↑	*** P5	*** C 123	M98002031	*** P3	*** B 108
M90602003	*** P9	*** E 149	M91084004	*** P9	*** E 141	↑	*** P7	*** D 121	M98002052	*** P15	*** H 138
M90605002	*** P19	*** K 104	M91106022	*** P19	*** K 116	↑	*** P17	*** J 136	M98003021	*** P23	*** M 107
M90605010	*** P5	*** C 104	M91118002	*** P17	*** J 133	↑	*** P19	*** K 135	M98004017	*** P9	*** E 129
↑	*** P9	*** E 101	M91119002	*** P11	*** F 101	↑	*** P21	*** L 102	MA20A0361	*** P5	*** C 109
M90631050	*** P15	*** H 133	↑	*** P17	*** J 130	↑	*** P25	*** N 103	MA20A6688	*** P27	*** P 104
M90634050	*** P15	*** H 139	M91127015	*** P7	*** D 108	↑	*** P29	*** Q 102	MA21A0256	*** P33	*** S 115
M90801010	*** P19	*** K 110	M91150003	*** P9	*** E 124	M94003017	*** P13	*** G 119	MA21A1256	*** P33	*** S 116
M90806002	*** P15	*** H 136	M91182080	*** P3	*** B 141	M94003021	*** P15	*** H 122	MA30A0571	*** P31	*** R 125
↑	*** P31	*** R 101	M91201045	*** P19	*** K 127	M94007017	*** P13	*** G 104	MA30A0757	*** P25	*** N 108
M90807063	*** P19	*** K 119	M91304010	*** P17	*** J 122	↑	*** P15	*** H 102	MA35A0166	*** P29	*** Q 108
M90815002	*** P11	*** F 137	↑	*** P21	*** L 103	↑	*** P19	*** K 140	MA35A0256	*** P33	*** S 113
M90822060	*** P19	*** K 126	M91305010	*** P21	*** L 108	↑	*** P21	*** L 115	MA35A1256	*** P33	*** S 114

索引
INDEX-2

部品コード Parts No.	ページ Page	Fig No.	部品コード Parts No.	ページ Page	Fig No.	部品コード Parts No.	ページ Page	Fig No.	部品コード Parts No.	ページ Page	Fig No.
MB10M0256	*** P33 ***	S 110	MH10A0722	*** P17 ***	J 118	MJ60A0364	*** P11 ***	F 113	MJ60A0982	*** P15 ***	H 132
MB60A0201	*** P31 ***	R 118	MH10A0833	*** P11 ***	F 106	MJ60A0383	*** P11 ***	F 120	MJ60A0983	*** P15 ***	H 134
MB60A0620	*** P25 ***	N 125	MH10A0980	*** P15 ***	H 137	MJ60A0413	*** P25 ***	N 128	MJ60A1228	*** P21 ***	L 101
MB60A1620	*** P31 ***	R 121	MH10A0981	*** P15 ***	H 145	MJ60A0416	*** P3 ***	B 105	MJ60A1245	*** P33 ***	S 118
MB60A2620	*** P31 ***	R 120	MH10A0FSW	*** P31 ***	R 127	MJ60A0420	*** P21 ***	L 104	MJ60A1339	*** P3 ***	B 101
MB60A5780	*** P25 ***	N 124	MH10A1722	*** P11 ***	F 118	MJ60A0422	*** P15 ***	H 131	MJ60A1359	*** P21 ***	L 106
MB61A1571	*** P7 ***	D 118	MH10A2701	*** P13 ***	G 140	MJ60A0426	*** P5 ***	C 124	MJ60A1364	*** P17 ***	J 111
↑	*** P23 ***	M 111	MH10A3181	*** P9 ***	E 152	MJ60A0429	*** P5 ***	C 116	↑	*** P21 ***	L 127
MB62A0757	*** P25 ***	N 109	MH10E0193	*** P31 ***	R 115	MJ60A0434	*** P7 ***	D 117	MJ60A1383	*** P17 ***	J 113
MB62A4601	*** P3 ***	B 144	MH10E0456	*** P11 ***	F 902	MJ60A0450	*** P17 ***	J 114	MJ60A1416	*** P3 ***	B 111
↑	*** P5 ***	C 121	MH10E0550	*** P9 ***	E 902	MJ60A0458	*** P21 ***	L 105	MJ60A1419	*** P31 ***	R 113
ME20A0120	*** P17 ***	J 103	MH13A0848	*** P13 ***	G 103	MJ60A0470	*** P5 ***	C 102	MJ60A1420	*** P23 ***	M 103
ME20A2780	*** P27 ***	P 103	↑	*** P19 ***	K 141	MJ60A0471	*** P13 ***	G 125	MJ60A1422	*** P3 ***	B 121
ME35E0180	*** P31 ***	R 116	MH25A0682	*** P17 ***	J 129	MJ60A0472	*** P5 ***	C 103	MJ60A1426	*** P5 ***	C 127
ME40A0368	*** P29 ***	Q 109	MH27A0660	*** P11 ***	F 132	MJ60A0476	*** P23 ***	M 134	MJ60A1429	*** P5 ***	C 113
ME40A0758	*** P5 ***	C 120	MH27A0833	*** P17 ***	J 125	MJ60A0477	*** P15 ***	H 115	MJ60A1434	*** P13 ***	G 136
ME60A0361	*** P5 ***	C 114	MH27A1454	*** P17 ***	J 128	MJ60A0482	*** P13 ***	G 126	MJ60A1450	*** P17 ***	J 105
MF00A2780	*** P27 ***	P 109	MH27E0383	*** P11 ***	F 903	MJ60A0484	*** P15 ***	H 124	MJ60A1484	*** P19 ***	K 133
MF01E0411	*** P19 ***	K 901	MH27E0580	*** P11 ***	F 904	MJ60A0500	*** P9 ***	E 134	MJ60A1500	*** P3 ***	B 134
MF06A1620	*** P31 ***	R 117	MH40A0456	*** P21 ***	L 117	MJ60A0508	*** P11 ***	F 116	MJ60A1508	*** P17 ***	J 108
MF10A0149	*** P31 ***	R 112	MH40A0620	*** P7 ***	D 124	MJ60A0523	*** P21 ***	L 129	MJ60A1571	*** P25 ***	N 129
MF10A0181	*** P9 ***	E 137	MH40A0809	*** P7 ***	D 135	MJ60A0556	*** P13 ***	G 129	MJ60A1599	*** P7 ***	D 123
MF10A0325	*** P11 ***	F 130	MH40A0958	*** P7 ***	D 132	MJ60A0567	*** P3 ***	B 118	MJ60A1601	*** P3 ***	B 117
MF10A0555	*** P13 ***	G 128	MH40A1620	*** P5 ***	C 119	MJ60A0571	*** P15 ***	H 141	MJ60A1688	*** P27 ***	P 108
MF13A0683	*** P17 ***	J 106	MH40A1958	*** P7 ***	D 130	MJ60A0573	*** P13 ***	G 132	MJ60A1722	*** P13 ***	G 108
MF13A1683	*** P17 ***	J 115	MH40A2601	*** P7 ***	D 126	MJ60A0595	*** P7 ***	D 125	MJ60A1739	*** P7 ***	D 116
MF13E6456	*** P17 ***	J 903	MH40A2958	*** P7 ***	D 131	MJ60A0600	*** P9 ***	E 125	MJ60A1740	*** P27 ***	P 115
MF20A0130	*** P29 ***	Q 105	MH50A0739	*** P7 ***	D 104	MJ60A0601	*** P3 ***	B 122	MJ60A1742	*** P3 ***	B 127
MF20A0229	*** P17 ***	J 134	MH51A0101	*** P33 ***	S 104	MJ60A0602	*** P7 ***	D 129	MJ60A1751	*** P13 ***	G 111
MF25B0123	*** P17 ***	J 102	MH51A1101	*** P33 ***	S 105	MJ60A0625	*** P13 ***	G 135	MJ60A1758	*** P5 ***	C 117
↑	*** P31 ***	R 109	MH51A2101	*** P33 ***	S 106	MJ60A0664	*** P11 ***	F 134	MJ60A1770	*** P7 ***	D 134
MG42A0181	*** P11 ***	F 135	MH60T0497	*** P25 ***	N 130	MJ60A0682	*** P11 ***	F 102	MJ60A1780	*** P3 ***	B 119
↑	*** P33 ***	S 117	MJ40A0257	*** P9 ***	E 117	MJ60A0688	*** P27 ***	P 107	MJ60A1799	*** P5 ***	C 128
MG43A0181	*** P9 ***	E 151	MJ40A0361	*** P5 ***	C 126	MJ60A0691	*** P3 ***	B 143	MJ60A1848	*** P17 ***	J 110
MG43A1181	*** P9 ***	E 140	MJ40A0477	*** P21 ***	L 131	MJ60A0696	*** P3 ***	B 129	MJ60A1849	*** P19 ***	K 142
↑	*** P13 ***	G 123	MJ40A0601	*** P21 ***	L 138	MJ60A0721	*** P11 ***	F 122	MJ60A1910	*** P7 ***	D 111
MG44E0125	*** P17 ***	J 101	MJ40A0626	*** P9 ***	E 116	MJ60A0722	*** P13 ***	G 114	MJ60A1950	*** P19 ***	K 131
MG75A1476	*** P9 ***	E 128	MJ40A1601	*** P21 ***	L 143	MJ60A0734	*** P31 ***	R 123	MJ60A2339	*** P3 ***	B 103
MH10A0160	*** P31 ***	R 103	MJ40E0747	*** P21 ***	L 901	MJ60A0739	*** P7 ***	D 109	MJ60A2359	*** P23 ***	M 125
MH10A0267	*** P15 ***	H 111	MJ41A0963	*** P25 ***	N 131	MJ60A0740	*** P27 ***	P 110	MJ60A2364	*** P21 ***	L 124
MH10A0416	*** P11 ***	F 108	MJ60A0131	*** P29 ***	Q 104	MJ60A0742	*** P7 ***	D 103	MJ60A2426	*** P5 ***	C 125
↑	*** P17 ***	J 124	MJ60A0132	*** P17 ***	J 135	MJ60A0751	*** P15 ***	H 106	MJ60A2429	*** P5 ***	C 118
MH10A0417	*** P9 ***	E 123	MJ60A0161	*** P3 ***	B 139	MJ60A0755	*** P23 ***	M 114	MJ60A2434	*** P15 ***	H 130
MH10A0454	*** P11 ***	F 105	MJ60A0220	*** P13 ***	G 120	MJ60A0770	*** P13 ***	G 117	MJ60A2454	*** P21 ***	L 110
MH10A0530	*** P11 ***	F 127	MJ60A0228	*** P21 ***	L 109	MJ60A0786	*** P21 ***	L 114	MJ60A2476	*** P3 ***	B 130
MH10A0572	*** P11 ***	F 104	MJ60A0230	*** P11 ***	F 119	MJ60A0799	*** P3 ***	B 138	MJ60A2484	*** P21 ***	L 136
↑	*** P17 ***	J 126	MJ60A0237	*** P7 ***	D 110	MJ60A0834	*** P19 ***	K 113	MJ60A2508	*** P25 ***	N 120
MH10A0584	*** P9 ***	E 136	MJ60A0245	*** P13 ***	G 130	MJ60A0839	*** P19 ***	K 118	MJ60A2571	*** P27 ***	P 101
MH10A0602	*** P15 ***	H 125	MJ60A0257	*** P27 ***	P 114	MJ60A0848	*** P15 ***	H 101	MJ60A2601	*** P3 ***	B 110
↑	*** P19 ***	K 134	MJ60A0262	*** P15 ***	H 109	MJ60A0849	*** P3 ***	B 147	MJ60A2722	*** P15 ***	H 104
↑	*** P21 ***	L 137	MJ60A0267	*** P15 ***	H 105	MJ60A0851	*** P13 ***	G 122	MJ60A2742	*** P17 ***	J 120
↑	*** P23 ***	M 121	MJ60A0339	*** P3 ***	B 116	MJ60A0901	*** P15 ***	H 118	MJ60A2751	*** P13 ***	G 113
MH10A0626	*** P15 ***	H 113	MJ60A0350	*** P19 ***	K 120	MJ60A0910	*** P19 ***	K 125	MJ60A2758	*** P5 ***	C 110
MH10A0663	*** P11 ***	F 131	MJ60A0352	*** P21 ***	L 111	MJ60A0920	*** P21 ***	L 133	MJ60A2770	*** P15 ***	H 120
MH10A0722	*** P11 ***	F 109	MJ60A0359	*** P21 ***	L 107	MJ60A0950	*** P19 ***	K 128	MJ60A2780	*** P31 ***	R 106

索引
INDEX-3

部品コード Parts No.	ページ Page	Fig No.	部品コード Parts No.	ページ Page	Fig No.	部品コード Parts No.	ページ Page	Fig No.	部品コード Parts No.	ページ Page	Fig No.
MJ60A2799	*** P7	*** D 133	MJ60B3339	*** P3	*** B 133	MS01A0155	*** P11	*** F 128			
MJ60A2848	*** P11	*** F 114	MJ60B3508	*** P25	*** N 122	MS02A0101	*** P33	*** S 101			
MJ60A2910	*** P7	*** D 113	MJ60B4508	*** P21	*** L 119	MS02A0128	*** P11	*** F 136			
MJ60A2920	*** P15	*** H 121	MJ60B5339	*** P25	*** N 102	↑	*** P31	*** R 108			
MJ60A3339	*** P3	*** B 112	MJ60B5508	*** P21	*** L 120	MS02A1101	*** P5	*** C 105			
MJ60A3359	*** P23	*** M 126	MJ60B6339	*** P3	*** B 126	↑	*** P33	*** S 102			
MJ60A3426	*** P17	*** J 123	MJ60B6508	*** P25	*** N 114	MS02A2101	*** P33	*** S 103			
MJ60A3429	*** P5	*** C 106	MJ60B7508	*** P25	*** N 117	MS02A2456	*** P21	*** L 112			
MJ60A3434	*** P23	*** M 113	MJ60B8508	*** P25	*** N 118	MS03A0256	*** P33	*** S 111			
MJ60A3476	*** P25	*** N 112	MJ60B9508	*** P25	*** N 110	MS03A1256	*** P33	*** S 112			
MJ60A3484	*** P21	*** L 142	MJ60C0508	*** P25	*** N 119	MS06A0567	*** P31	*** R 126			
MJ60A3508	*** P25	*** N 121	MJ60C1508	*** P21	*** L 126	MS14A0682	*** P11	*** F 111			
MJ60A3571	*** P23	*** M 102	MJ60C2508	*** P21	*** L 128	MS14A1180	*** P9	*** E 127			
MJ60A3601	*** P25	*** N 116	MJ60E0190	*** P9	*** E 901	MS14E0180	*** P9	*** E 126			
MJ60A3742	*** P23	*** M 109	MJ60E0366	*** P27	*** P 901	MV30A0256	*** P15	*** H 112			
MJ60A3751	*** P15	*** H 107	MJ60E0456	*** P11	*** F 901	↑	*** P33	*** S 108			
MJ60A3780	*** P31	*** R 107	MJ60E0599	*** P25	*** N 901	MV30A1256	*** P33	*** S 109			
MJ60A3910	*** P15	*** H 143	MJ60E0688	*** P27	*** P 106	MV35A0106	*** P33	*** S 107			
MJ60A4339	*** P3	*** B 104	MJ60E1456	*** P17	*** J 904						
MJ60A4426	*** P21	*** L 123	MJ60E1688	*** P27	*** P 111						
MJ60A4429	*** P5	*** C 115	MJ60E1747	*** P23	*** M 124						
MJ60A4456	*** P13	*** G 131	MJ60E2456	*** P17	*** J 902						
MJ60A4476	*** P3	*** B 135	MJ60E3456	*** P17	*** J 901						
MJ60A4484	*** P23	*** M 122	MJ61A0476	*** P9	*** E 103						
MJ60A4508	*** P19	*** K 138	MJ61A0567	*** P9	*** E 109						
MJ60A4601	*** P23	*** M 118	MJ61A0571	*** P9	*** E 113						
MJ60A4770	*** P23	*** M 131	MJ61A0601	*** P9	*** E 107						
MJ60A4780	*** P21	*** L 116	MJ61A0602	*** P9	*** E 121						
MJ60A5339	*** P3	*** B 136	MJ61A0757	*** P9	*** E 110						
MJ60A5426	*** P29	*** Q 103	MJ61A0758	*** P9	*** E 104						
MJ60A5476	*** P21	*** L 118	MJ61A0770	*** P9	*** E 108						
MJ60A5484	*** P25	*** N 104	MJ61A1476	*** P9	*** E 114						
MJ60A5508	*** P19	*** K 139	MJ61A1601	*** P9	*** E 122						
MJ60A5601	*** P15	*** H 126	MJ61A1742	*** P9	*** E 115						
MJ60A5747	*** P23	*** M 106	MJ61A1757	*** P9	*** E 119						
MJ60A5770	*** P13	*** G 106	MJ61A1770	*** P9	*** E 111						
MJ60A6508	*** P13	*** G 102	MJ61A1830	*** P3	*** B 142						
MJ60A6770	*** P9	*** E 146	MJ61A2339	*** P9	*** E 102						
MJ60A7508	*** P13	*** G 101	MJ61E1991	*** P31	*** R 114						
MJ60A7601	*** P19	*** K 137	ML10A0555	*** P13	*** G 127						
MJ60A8339	*** P3	*** B 131	MN10A0135	*** P27	*** P 105						
MJ60A8508	*** P7	*** D 122	MN10A0477	*** P9	*** E 144						
MJ60A8601	*** P7	*** D 119	MN10E0175	*** P9	*** E 148						
MJ60A9339	*** P13	*** G 110	MN60A0411	*** P19	*** K 130						
MJ60A9508	*** P11	*** F 115	MN60A0837	*** P19	*** K 102						
MJ60A9601	*** P25	*** N 106	MN60A2742	*** P19	*** K 112						
MJ60B0339	*** P13	*** G 112	MN82A0192	*** P19	*** K 105						
MJ60B0508	*** P25	*** N 105	MN82A0551	*** P19	*** K 107						
MJ60B0601	*** P31	*** R 105	MN82A1154	*** P19	*** K 108						
MJ60B1339	*** P17	*** J 131	MN82A1192	*** P19	*** K 106						
MJ60B1508	*** P17	*** J 107	MP10B0554	*** P9	*** E 142						
MJ60B1601	*** P3	*** B 125	MP41A0838	*** P19	*** K 115						
MJ60B2339	*** P7	*** D 107	↑	*** P33	*** S 119						
MJ60B2508	*** P23	*** M 110	MP60A1187	*** P9	*** E 143						
MJ60B2601	*** P5	*** C 129	MP69A0838	*** P33	*** S 120						

名菱テクニカ株式会社

お問い合わせは下記へどうぞ

縫製機械事業部 縫製営業部 〒488-0052 愛知県尾張旭市下井町下井 2039-1

代表電話番号 (0561)51-1231 代表FAX番号 (0561)51-1212