



## 工業用ミシン部品カタログ

## Industrial Sewing Machine Parts Catalog

Model LY3-6840-B0T

	目 次	CONTENTS	Page
A	本 体 関 係 ( I )	Arm bed & it's accessories ( I ) .....	2
B	本 体 関 係 ( II )	Arm bed & it's accessories ( II ) .....	4
C	縫 い 機 構 ( I )	Sewing mechanism ( I ) .....	6
D	縫い機構(II)および下送り機構	Sewing mechanism ( II ) & feed rock lower shaft mechanism ....	8
E	送 り 調 節 機 構	Stitch length mechanism .....	10
F	上 部 水 平 送 り 機 構	Upper feed rock shaft mechanism .....	12
G	上 部 上 下 送 り 機 構	Upper feed lifting rock shaft mechanism .....	14
H	押 え 機 構	Presser foot mechanism .....	16
J	タッチバックおよび検出器機構	Touch back mechanism & detector mechanism .....	18
K	給 油 機 構	Oil lubrication mechanism .....	20
L	付 属 品	Accessories .....	22
	索 引	Index .....	24



# ミシン部品コードの採番基準

## SPARE PARTS No. Designation system

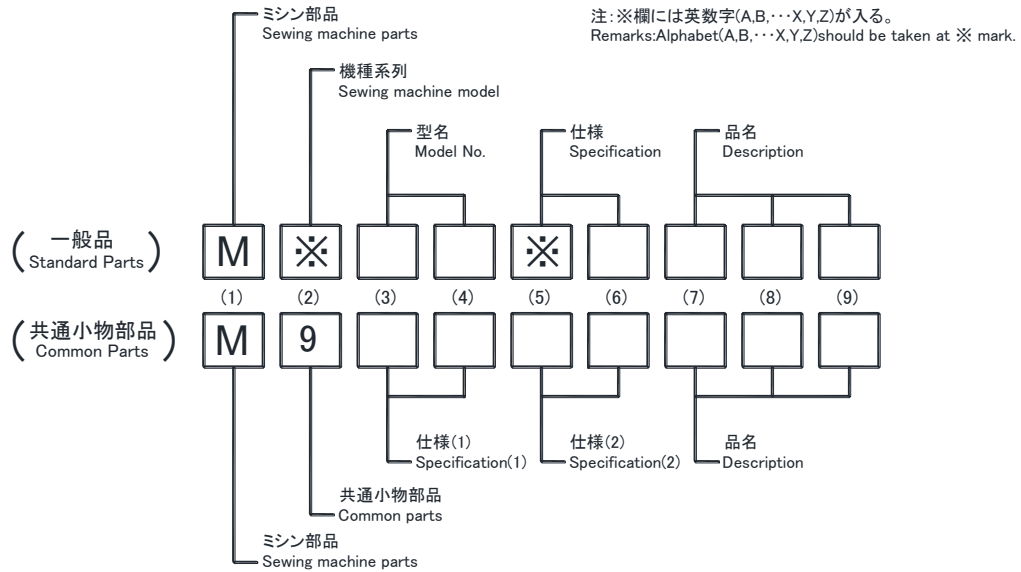

[ 例 ]  
Example

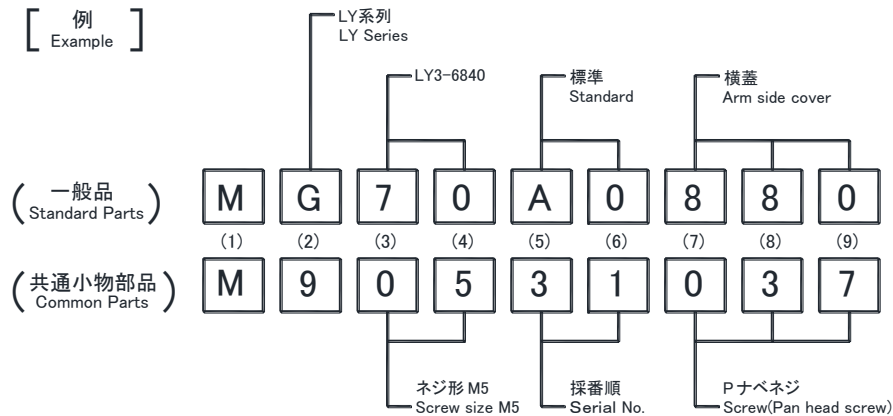

注: 一般品についての機種型名は、その部品が最初に使用された機種型名を示します。従って長期にわたる場合は、機種の変更が行われるため、当初の機種以外の機種で使用されている場合があります。  
Sewing machine Models, of Standard Parts are Indicated model of these parts are registered firstly. Parts are used for not only the indicated model, but also another models, in reason of New development, improvement after.

### パーツカタログご利用に際して Information on use of the parts catalog

- ・補用品ご注文の際は、部品コードでご注文下さい。また、このパーツブックの管理番号と発行年月(表紙右下,例えば、P-1...202104)モデル機械番号を、合わせてご連絡頂ければ幸いです。
- ・一部の部品について、改良のため予告なしに変更になる場合がありますのでご了承下さい。
- ・このパーツカタログは、2021年4月のデータにもとづいて作成されたものです。
- ・部品コード欄が、 — となっている部品は、補給いたしません。ただし組コードが記載されているものは、組部品として補給いたしますので、組コードでご注文下さい。
- ・使用個数欄の英数字組合せ文字は、このモデル番号のサブ機械番号をしめています。
- ・尚、本パーツブックの記載内容にお気付きの点がありましたら、お知らせ頂ければ幸いです。

- ・When ordering any spare part, please specify its part code. In addition, please specify the management number and issued date of this parts catalog (e.g.P-1 202104 indicated at bottom right of the front cover) and the machine model number.
- ・Some parts are subject to change due to modification without notice.
- ・This parts catalog is based the as of April 2021.
- ・Any part marked-in the part code column will not be supplied. When a part has its assembly code, please specify the assembly code because that part is supplied as an assembly part.
- ・Alphanumerical characters indicated in the required quantity column indicate the sub machine number of this model number.
- ・Please write to us if you have any question on this parts catalog.



[A] 本体関係 ( I )  
ARM BED & IT'S ACCESSORIES ( I )

Fig. No.	変更 Mod	部品コード Parts. No.	部 品 名	Description	使用数 Amt. Req. BOT
A01		M90883080	ゴムセン	Rubber plug $\phi$ 8.8	5
A02		M90573080	ゴムセン	Rubber plug $\phi$ 5.7	1
A03		M91508004	プ ラマイネジ	Screw 15/64 (28) x8	2
A04		M90105054	シールワッシャ W6	Seal washer 6	2
A05		M91109004	サ ガ ネツキ プ ラマイネジ	Screw 11/64 (40) X8	4
A06		MG75A0880	ヨコブ タ 1	Arm side cover 1	1
A07		MG75A0691	ガ スケット	Gasket for arm side cover	1
A08		M91910080	ゴムセン	Rubber plug $\phi$ 19	4
A09		M91109002	ヒラネジ	Screw 11/64 (40) X7	1
A10		MG75A0180	イトアンナイ	Thraed guide	1
A11		MG75A0572	ツルマキハネ	Coil spring	1
A12		M90431060	ピン	Stopper pin	1
A13		M94006021	ロツカア ナツキ トメネジ M4X6	Soket set screw M4X6	1
A14		MG70A0841	メモリイタ	Stitch length indicating plate	1
A15		MG70A1631	ダイヤル	Dial	1
A17		MF20A0135	アブ ラマト	Oil check window	1
A18		M91112004	プ ラマイネジ	Screw 11/64 (40) X11	8
A19		MG70A0600	トツブ カハ	Top cover	1
A20		MG75A1691	ガ スケット	Gasket for top cover	1
A21		M92200080	セン	Rubber plug $\phi$ 22	2
A22		M92900080	セン	Rubber plug $\phi$ 29	1
A23		M92601080	セン	Rubber plug $\phi$ 26	2
A24		MG70A1250	オイルゲージ	Oil gauge	1
A25		MG70A0500	セン	Rubber plug $\phi$ 35.5	1
A26		MG75A0291	ジ ヨウゲ オクリチヨウセツカム	Upper feed lifting regulator cam	1
A27		MF03A0584	テンヒンカハ	Thead take-up cover	1
A28		M91108001	トメネジ	Set screw 11/64 (40) x5.5	1
A29		M91510002	ヒラネジ	Screw 15/64 (28) x12	9
A30		M90908003	マルヒラネジ	Screw 9/64 (40) x6	2
A31		MG43A0181	イトアンナイ	Thread guide	1
A32		M91508001	アタマナシトメネジ	Set screw 15/64 (28) x6.8	1
A33		M91604080	セン	Rubber plug $\phi$ 16	1
A34		M90811060	ハイコウピン	Pin	1
A35		M90819060	ハイコウピン	Pin	1
A36		M91106004	プ ラマイネジ	Screw 11/64 (40) x8	1

㊦ 本体関係(Ⅱ)  
 ARM BED AND IT'S ACCESSORIES(Ⅱ)

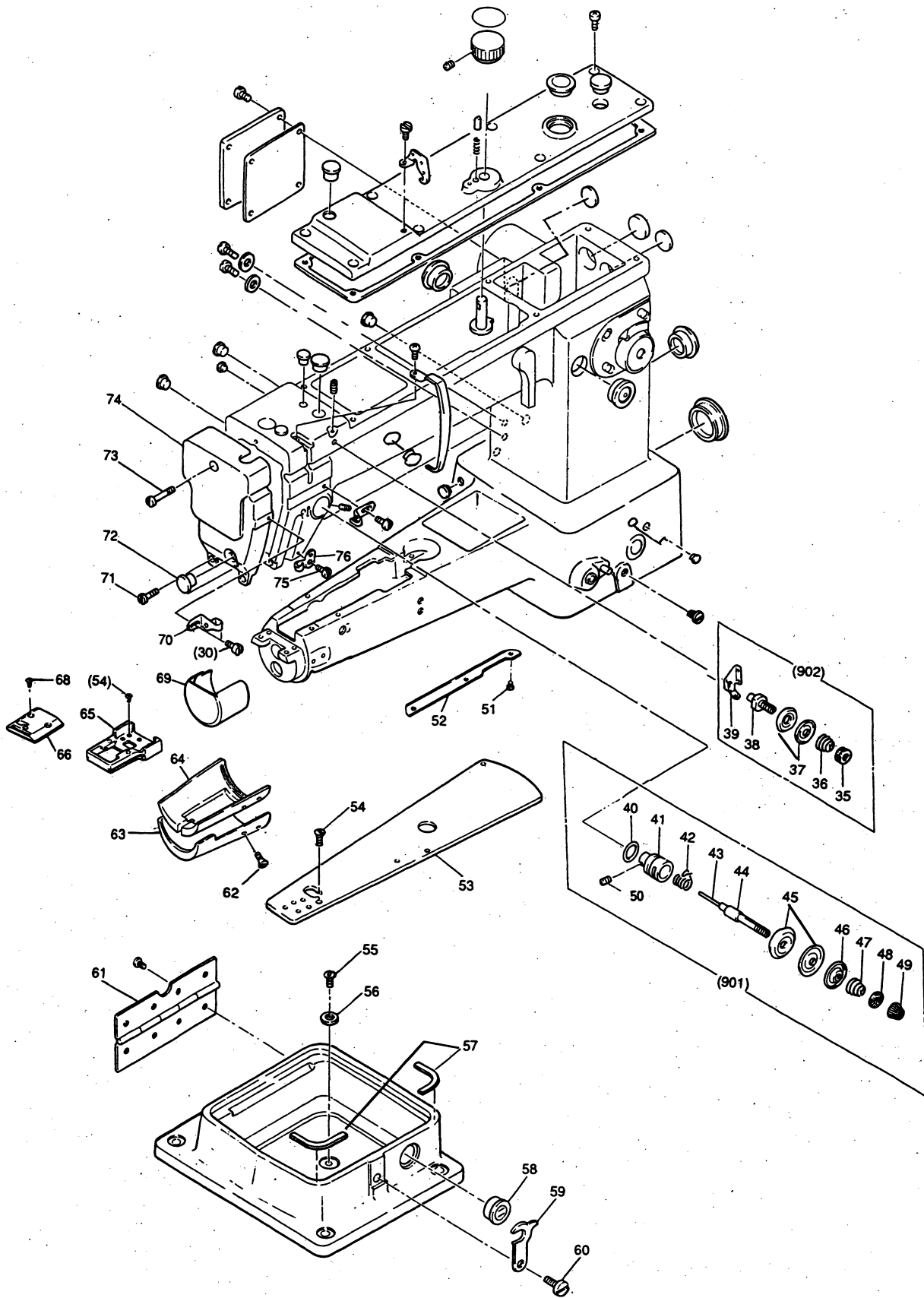

[B] 本体関係 (Ⅱ)  
ARM BED & IT'S ACCESSORIES (Ⅱ)

Fig. No.	変更 Mod	部品コード Parts. No.	部 品 名	Description	使用数 Amt. Req. BOT
B35		M91101046	ツミナツト	Thumb nut 11/64 (40)	1
B36		MF36A0245	エンスイハネ	Thread tension spring	1
B37		MF10A1555	チヨウシザラ	Thread tension disc	2
B38		MF90A0553	チヨウシホウ	Thread tension stud	1
B39		MF00A0181	イトアンナイ	Thread guide	1
B40		M91501085	Oリング	O-ring S15	1
B41		MF10A0709	ブツシュ	Thread tension regulator bushing	1
B42		MF02A0187	イトトリハネ	Thread take-up spring	1
B43		M90228060	ピン	Thread tension pin	1
B44		MF02A0553	チヨウシホウ	Thread tension stud	1
B45		MF10A0555	チヨウシザラ	Thread tension discs	2
B46		MH40A0556	チヨウシザラオサエ	Thread tension releasing disc	1
B47		MG52A0245	エンスイハネ	Thread tension spring	1
B48		MT60A0802	マワリトメ	Thumb nut revolution stopper	1
B49		M91610046	ツミナツト	Thumb nut 1/4 (40)	1
B50		M90901002	ヒラネジ	Screw 9/64 (40) x4	1
B51		M90906002	ヒラネジ	Screw 9/64 (40) x4.5	3
B52		MG70A0691	ガスケット	Gasket for top cover	1
B53		MG70A2339	シリンダーカバー上	Cylinder cover (upper)	1
B54		M90911010	サラネジ	Screw 9/64 (40) x5.5	7
B55		M92002002	ヒラネジ	Screw 5/16 (28) x10	1
B56		M97001052	トクシザガネ	Washer	1
B57		MG70A0419	ホウシヨクム	Vibration preventing rubber	2
B58		MG70A0250	オイルゲージ	Oil gauge	1
B59		MG61A0361	カケガネ	Spring holder	1
B60		M91525015	ダツツキヒラネジ	Stud screw 5/16 (28) x11.3	1
B61		MG70E0560	ヒラガタチヨウバンクミタテ	Hinge	1
B62		M90906010	サラネジ	Screw 9/64 (40) x9.5	4
B63		MG70A0339	シリンダーカバー下	Cylinder cover (lower)	1
B64		MG70A0416	シリンダーカバーゴム	Cover gasket	1
B65		MG70A0603	ハリイタトリツケタテ	Needle plate rest	1
B66		MG70A0101	ハリイタ	Needle plate	1
B67		MG70A1101	ハリイタ (オプション)	Needle plate (option)	1
B68		M91102011	マルサラネジ	Screw 11/64 (40) x8.5	2
B69		MG70A1339	カマカバー	Hook cover	1
B70		MG43A1181	イトアンナイ	Thread guide	1
B71		M91106003	マルヒラネジ	Screw 11/64 (40) x20	2
B72		M91182080	セン	Rubber plug $\phi$ 11.8	1
B73		M91070003	マルヒラネジ	Screw M4X30	1
B74		MG75A1830	メンイタ	Face plate	1
B75		M90906002	ヒラネジ	Screw 9/64 (40) x4.5	1
B76		MQ50A0181	イトアンナイ	Thread guide	1
B901		MG75E0210	チヨウセツキクミタテ	Thread tension regulator complete	1
B902		MF00E0550	イトチヨウセツキクミタテ	Pre-tension assy.	1

㉞ 縫い機構(I)  
SEWING MECHANISM(I)

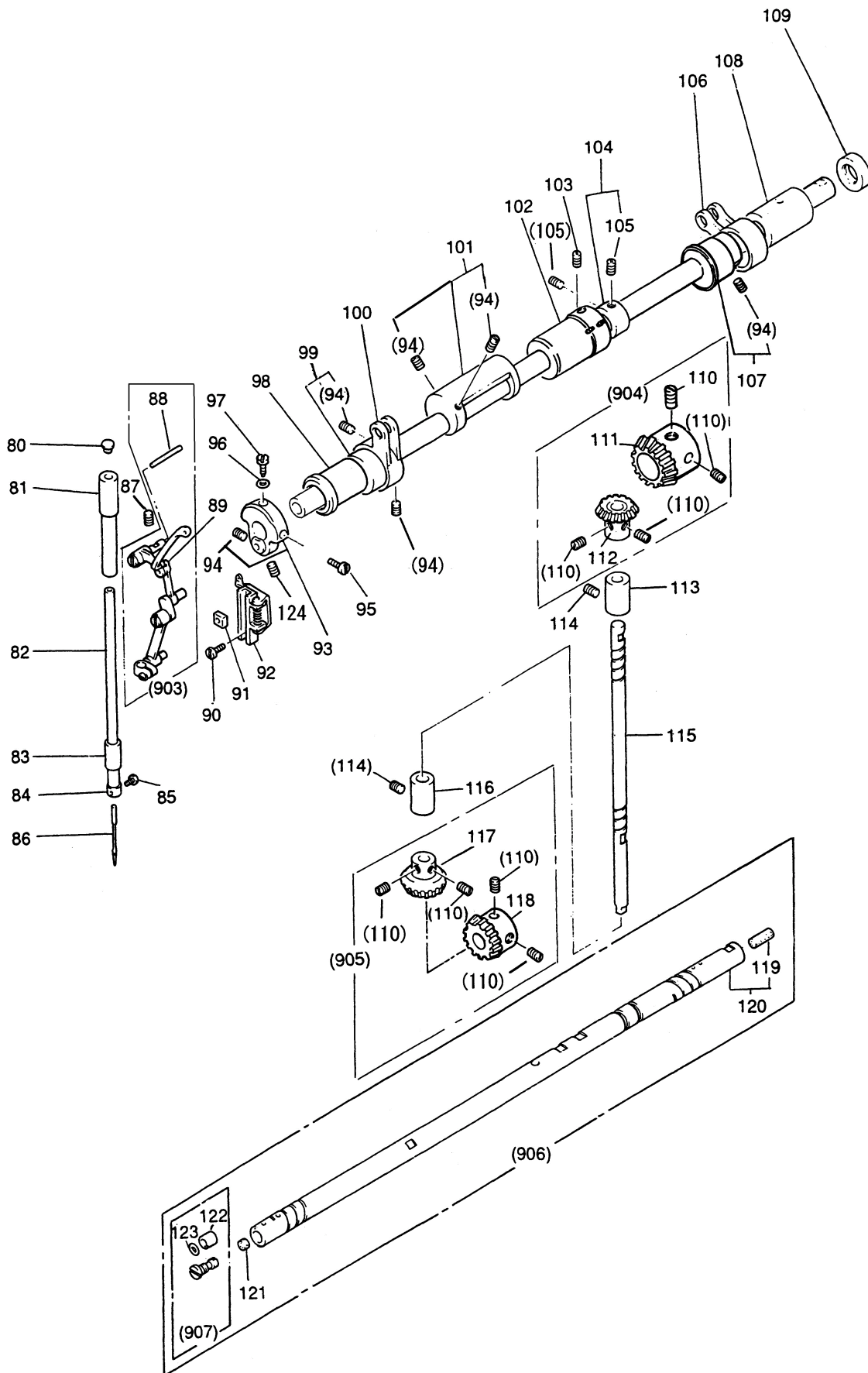



[C] 縫い機構 ( I )  
SEWING MECHANISM ( I )

Fig. No.	変更 Mod	部品コード Parts. No.	部 品 名	Description	使用数 Amt. Req. BOT
C80		M90883080	ゴムセン	Rubber plug $\phi$ 8.8	1
C81		MF60A0663	ハリボウメタルウエ	Needle bar bushing (upper)	1
C82		MG70A0660	ハリボウ	Needle bar	1
C83		MG75A0664	ハリボウメタルシタ	Needle bar bushing (lower)	1
C84		MG42A0181	イトアンナイ	Thread guide for needle bar	1
C85		M90815002	ヒラネジ	Screw 1/8(44)x4.5	1
C86		MG37A0128	ミシンハリ DPX17-22	Needle DPX17 #22	1
C87		M91513001	トメネジ	Set screw 15/64(28)x10	1
C88		MF01A0740	フェルト	Felt	1
C89		MF03A0417	ゴムワ	Oil shade cap	1
C90		M91106004	ブラマイネジ	Screw 11/64(40)x8	2
C91		MF10A0325	カクコマ	Square block	1
C92		MG44E0662	ハリクガイトクミタテ	Needle bar connecting link guide assy.	1
C93		MG70E0383	クランククミタテ	Crank with screw	1
C94		M91606001	トメネジ	Set screw 1/4(40)x6	7
C95		M91801002	ヒラネジ	Screw 9/32(28)X13	1
C96		M90700085	オリング	O-ring 1AP7	1
C97		M91802006	ヒラネジホウサキ	Screw 9/32(28)x14	1
C98		MG75A0232	ウワジクメタルヒタリ	Upper shaft bushing (left)	1
C99		MG75E0492	ヘンシンリンクミタテ	Upper feed lifting cam	1
C100		MG75A0956	レンゼツカン	Upper feed rock crank	1
C101		MG75E0693	バランソウエイトクミタテ	Balance weight	1
C102		MG70E0234	ウワジクメタルナカクミタテ	Upper shaft bushing assy.	1
C103		M91506001	トメネジ	Set screw 15/64(28)x7	1
C104		MF80A0352	カラークミタテ	Thrust Collar with screw	1
C105		M91602001	トメネジ	Set screw 1/4(40)x4	2
C106		MG75A2956	レンゼツカン	Upper feed rock Crank	1
C107		MG70E0760	ヘンシンリンクミタテ	Upper feed lifting cam	1
C108		MG75A0233	ウワジクメタルミキ	Upper shaft bushing (right)	1
C109		M91472086	オイルシール	Oil seal	1
C110		M91610001	トメネジ	Set screw 1/4(40)x7	8
C111		—	ウワジクカサハク ルマ	Upper shaft gear	1
C112		—	タテジクカサハク ルマウエ	Vertical shaft gear (upper)	1
C113		MG75A0521	タテジクメタル	Vertical shaft bushing (upper)	1
C114		M91513001	トメネジ	Set screw 15/64(28)X10	2
C115		MG70A0520	タテジク	Vertical shaft	1
C116		MF74B0522	タテジクメタルシタ	Vertical shaft bushing (lower)	1
C117		—	タテジクカサハク ルマシタ	Vertical shaft gear (lower)	1
C118		—	シタジクカサハク ルマ	Lower shaft gear	1
C119		M90740080	ゴムセン	Rubber plug $\phi$ 7.4	1
C120		MG70E0230	ウワジククミタテ	Arm shaft	1
C121		MF01A1740	フェルト	Felt	1
C122		MG75A0417	ゴムワ	Rubber bushing	1
C123		M90402085	オリング	O-ring S4	1
C124		M91602001	トメネジ	Set screw 1/4(40)x4	1
C903		MG70E0580	テンヒンゴムワクミタテ	Thread take-up lever assy.	1
C904		MG70E0330	カサハク ルマクミタテ	Bevel gear upper assy.	1
C905		MG70E1330	カサハク ルマクミタテ	Bevel gear lower assy.	1
C906		—	ウワジククミタテ	Upper shaft assy.	1
C907		M97006060	キユウチヨウセツヒンクミタテ	Oil amount adjusting pin assy.	1

□ 縫い機構(Ⅱ)および下送り機構

SEWING MECHANISM(Ⅱ) & FEED ROCK LOWER SHAFT MECHANISM

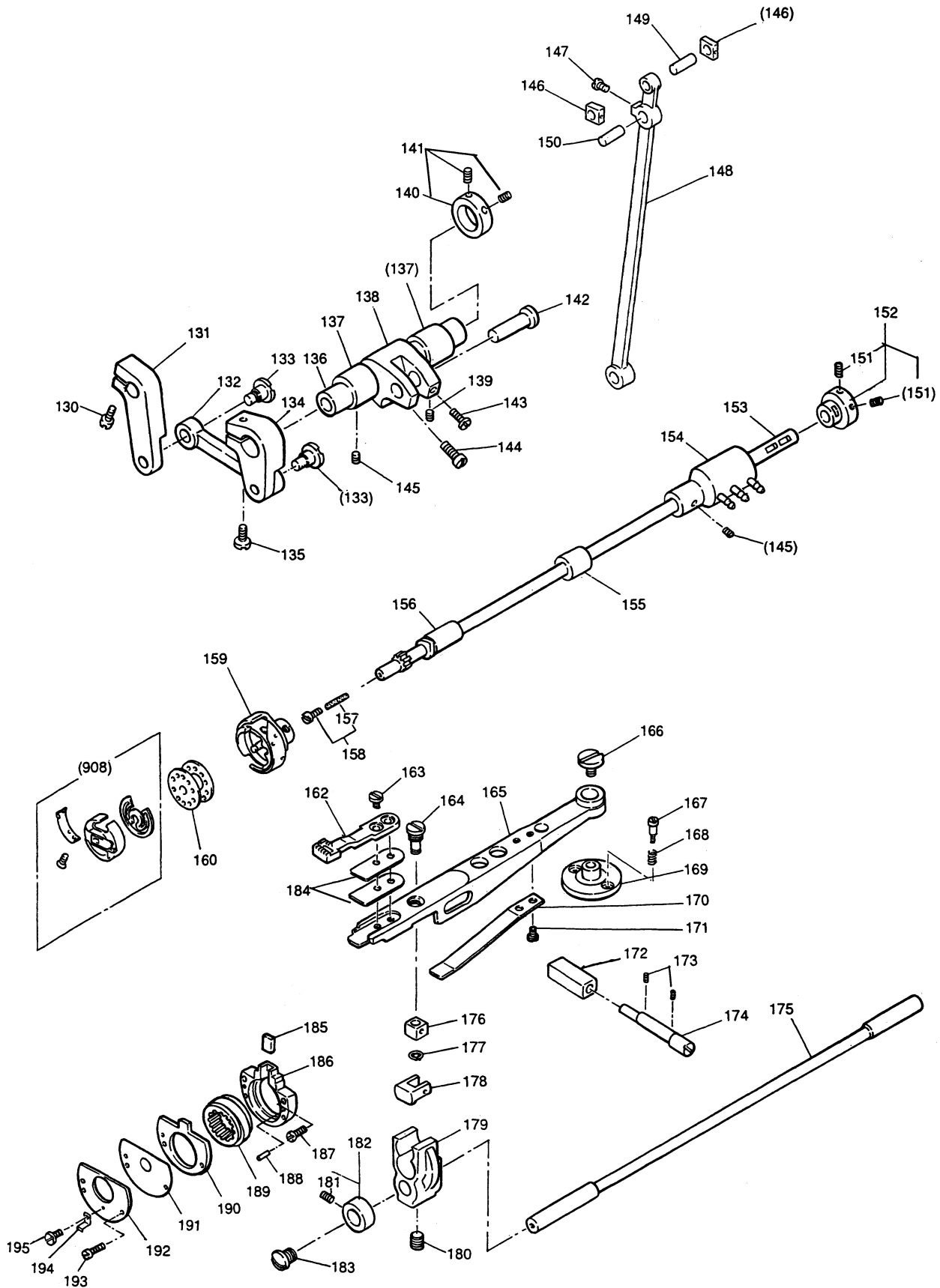

[D] 縫い機構 (Ⅱ) および下送り機構  
SEWING MECHANISM (Ⅱ) & FEED ROCK LOWER SHAFT MECHANISM

Fig. No.	変更 Mod	部品コード Parts. No.	部 品 名	Description	使用数 Amt. Req. BOT
D130		M91203002	ヒラネジ	Screw 3/16(28)X15	1
D131		MG70A2273	スィエイオクリウテ	Feed rock shaft crank	1
D132		MG70A1956	レンゼツカン	Connecting rod for upper feed	1
D133		M91687015	ダツツキヒラネジ	Stud screw 1/4(40)x7	2
D134		MG70A1273	スィエイオクリウテ	Feed rock shaft crank	1
D135		M91215002	ヒラネジ	Screw 3/16(28)X12	1
D136		MG70E0491	スィエイオクリウテクミタテ	Feed rock shaft assy.	1
D137		MG70A0285	スィエイオクリウテクメタル	Bushing for feed rock shaft	2
D138		MG70A0279	スィエイオクリウテミキ	Feed rock shaft crank (right)	1
D139		M91108001	トメネジ	Set screw 11/64(40)X5.5	1
D140		MF80A0352	カラークミタテ	Thrust Collar with screw	1
D141		M91602001	トメネジ	Set screw 1/4(40)x4	2
D142		M97013060	ツバツツキク	Pin	1
D143		M91516002	ヒラネジ	Screw 15/64(28)X8.5	1
D144		M91507002	ヒラネジ	Screw 15/64(28)X18	1
D145		M91111001	トメネジ	Set screw 11/64(40)x10	2
D146		MN40A0325	カクコマ	Square block	2
D147		M91521002	ヒラネジ	Screw 11/64(40)X7	1
D148		MG75A3956	レンゼツカン	Connecting rod for upper feed	1
D149		MG75A1454	ジク	Upper feed rock shaft	1
D150		MG75A0454	ジク	Upper feed rock shaft	1
D151		M91110001	トメネジ	Set screw 11/64(40)x8.5	2
D152		MG70E1352	カラークミタテ	Thrust collar with screw	1
D153		MG70A0450	シタジク	Lower shaft	1
D154		MG70E0453	シタジクメタルナカクミタテ	Lower shaft bushing	1
D155		MG70A1750	ブツシュ	Bushing	1
D156		MG70A0451	シタジクメタルヒタリ	Lower shaft bushing(left)	1
D157		MF05A0740	フィルタ	Oil felter for lower shaft	1
D158		M91259030	トクシユネジフェルトクミタテ	Special screw	1
D159		MG70E0120	カマクミタテ	Rotating hook assy.	1
D160		MF25B0123	ホビン	Bobbin	1
D161		MG70A1104	オクリ(オブション)	Feed dog	1
D162		MG70A0104	オクリ	Feed dog	1
D163		M90821002	ヒラネジ	Screw 1/8(44)X3.5	2
D164		M92204030	トクシユネジ	Screw 11/32(28)x16	1
D165		MG70A0281	オクリダイ	Feed bar	1
D166		M91191003	マルヒラネジ	Screw 11/64(40)x5	1
D167		M91142015	ダツツキヒラネジ	Stud screw 11/64(40)x8.2	2
D168		MG70A0572	ツルマキバネ	Coil spring	2
D169		MG70A2603	トリツケダイ	Feed bar stud	1
D170		MG70A0192	イタバネ	Spring plate	1
D171		M90815002	ヒラネジ	Screw 1/8(44)x4.5	2
D172		MG70A1325	カクコマ	Square block	1
D173		M91108001	トメネジ	Set screw 11/64(40)x5.5	2
D174		MG70A0761	ヘンシンピン	Eccentric shaft	1
D175		MG70A1491	スィエイオクリウテク	Feed rock shaft	1
D176		MG70A0325	カクコマ	Square block	1
D177		M90707065	エガタトメ 3	Retaining ring-E type 3	1
D178		MG70A0411	コロ	Slide block	1
D179		MG70A0273	スィエイオクリウテ	Feed rock shaft crank	1
D180		M92004001	トメネジ	Set screw 5/16(24)x7	1
D181		M91106001	トメネジ	Set screw 11/64(40)x3.75	2
D182		MG70E0352	カラークミタテ	Thrust Collar with screw	1
D183		M91190003	マルヒラネジ	Screw 11/64(40)x8	1
D184		MG70A0476	スペーサ	Spacer	2
D185		M95010063	ジヨウゲピン	Pin	1
D186		MG70A1603	トリツケダイ	Feed driving cam holder	1
D187		M91136002	ヒラネジ	Screw 11/64(40)x10	2
D188		M90310064	スプリングピン	Spring pin	2
D189		MG70A1760	ヘンシンリン	Feed driving cam	1
D190		MG70A0606	トクシユイタ	Feed driving cam holder	1
D191		MG70A0257	オサエイタ	Feed driving cam holder	1
D192		MG70A1257	オサエイタ	Feed driving cam holder	1
D193		M90807002	ヒラネジ	Screw 1/8(44)x10	2
D194		MG70A1192	イタバネ	Spring plate	1
D195		M90614002	ヒラネジ	Screw 3/32(56)x1.5	1
D908		MG44E0125	ホビンケース	Bobbin case	1

送り調節機構

STITCH LENGTH MECHANISM

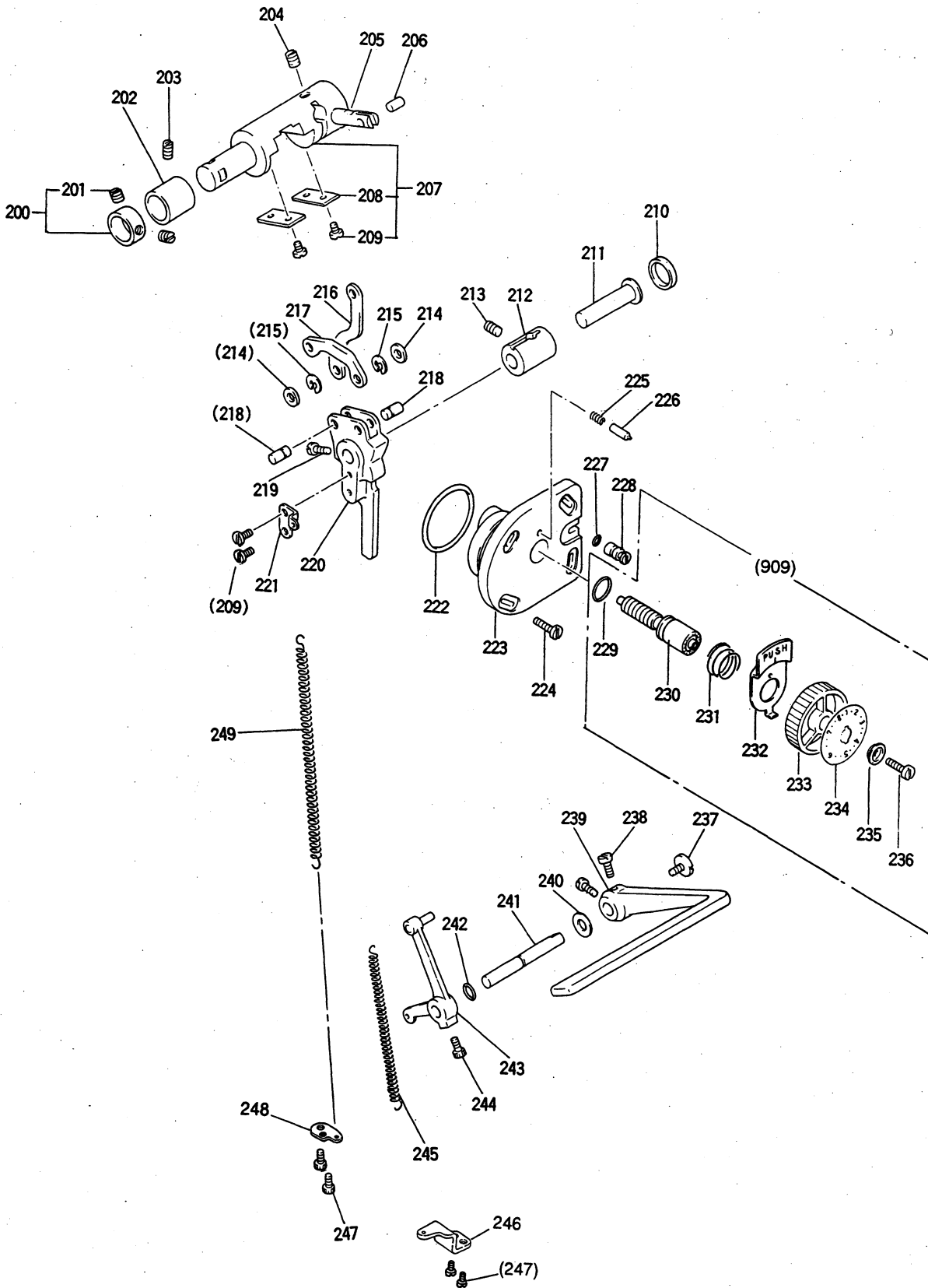

**[E] 送り調節機構**  
**STITCH LENGTH MECHANISM**

Fig. No.	変更 Mod	部品コード Parts. No.	部 品 名	Description	使用数 Amt. Req. BOT
E200		MF80A0352	カラークミタテ	Thrust collar with screw	1
E201		M91602001	トメネジ	Set screw 1/4 (40) X4	2
E202		MG75A0285	オクリジクメタル	Bushing	1
E203		M91108001	トメネジ	Set screw 11/64 (40) X5.5	1
E204		M91513001	トメネジ	Set screw 15/64 (28) X10	1
E205		MG75A0602	トリツカガネ	Bracket pin	1
E206		MG75A2454	ジク	Pin	1
E207		MG75E0321	カエシダイクミタテ	Reverse bar complete	1
E208		MN45A0154	アンナイイタ	Guide plate	2
E209		M91106004	プラマイネジ	Screw 11/64 (40) x8	6
E210		M92004080	セン	Rubber plug φ20	1
E211		M90904063	タンツクジク	Pin	1
E212		MF70A0750	ブツシュ	Bushing for feed regulator	1
E213		M91506001	トメネジ	Set screw 15/64 (28) X7	1
E214		MG75A1476	スペーサ	Spacer	2
E215		M90504065	エグタメワ 4	E-type stop ring 4	2
E216		MG75A0910	リンク	Link	1
E217		MG75A1910	リンク	Link	1
E218		MG75A3454	ジク	Pin	2
E219		M91516002	ヒラネジ	Screw 15/64 (28) x8.5	1
E220		MG75A0152	オクリチヨウセツカム	Feed regulator	1
E221		MF00A2708	カケガネ	Spring holder	1
E222		M93600085	オリング	O-ring S36	1
E223		MG75A0603	トリツカタイ	Bracket	1
E224		M91118002	ヒラネジ	Screw 11/64 (40) x10	4
E225		MF05A0572	ツルマキハネ	Coil spring	1
E226		MF00A0852	ピン	Stopper pin	1
E227		M90700085	オリング 1AP7	O-ring 1AP7	1
E228		MG75E0633	ヌイメチヨウセツジクミタテ	Feed regulator pin complete	1
E229		M91000085	オリング 1AP10A	O-ring 1AP10A	1
E230		MF85A0640	オクリチヨウセツネジ	Screw bar	1
E231		MF02A0245	エンズイハネ	Coil spring	1
E232		MF00A0950	レバ	Stopper pin releasing lever	1
E233		MG75A0631	ダイヤル	Dial	1
E234		MF03A0841	メモリイタ	Stitch length indicating plate	1
E235		MF00A0257	オサエガネ	Bushing	1
E236		M91215002	ヒラネジ	Screw 3/16 (28) x12	1
E237		M91207003	マルヒラネジ	Screw 3/16 (28) x6.5	1
E238		M91515002	ヒラネジ	Screw 15/64 (28) x10	2
E239		MF01A0632	ヌイメカゲレバ	Feed reversing lever	1
E240		M95003053	ハネサガネ	Spring washer	1
E241		MF00A0633	ヌイメカゲンジク	Feed reversing lever shaft	1
E242		M90600085	オリング 1AP6	O-ring 1AP6	1
E243		MF00E1635	ヌイメカゲンウテクミタテ	Reverse sewing crank assy.	1
E244		M91501007	マルヒラネジ ホウサキ	Screw 15/64 (28) x14.5	1
E245		MG75A1572	ツルマキハネ	Coil spring	1
E246		MG70A1361	カケガネ	Spring holder	1
E247		M91106004	プラマイネジ	Screw 11/64 (40) x8	4
E248		MG70A0361	カケガネ	Spring holder	1
E249		MG70A2572	ツルマキハネ	Coil spring	1
E909		MG70E0297	オクリチヨウセツネジクミタテ	Screw bar assy.	1

□ 上部水平送り機構  
UPPER FEED ROCK SHAFT MECHANISM

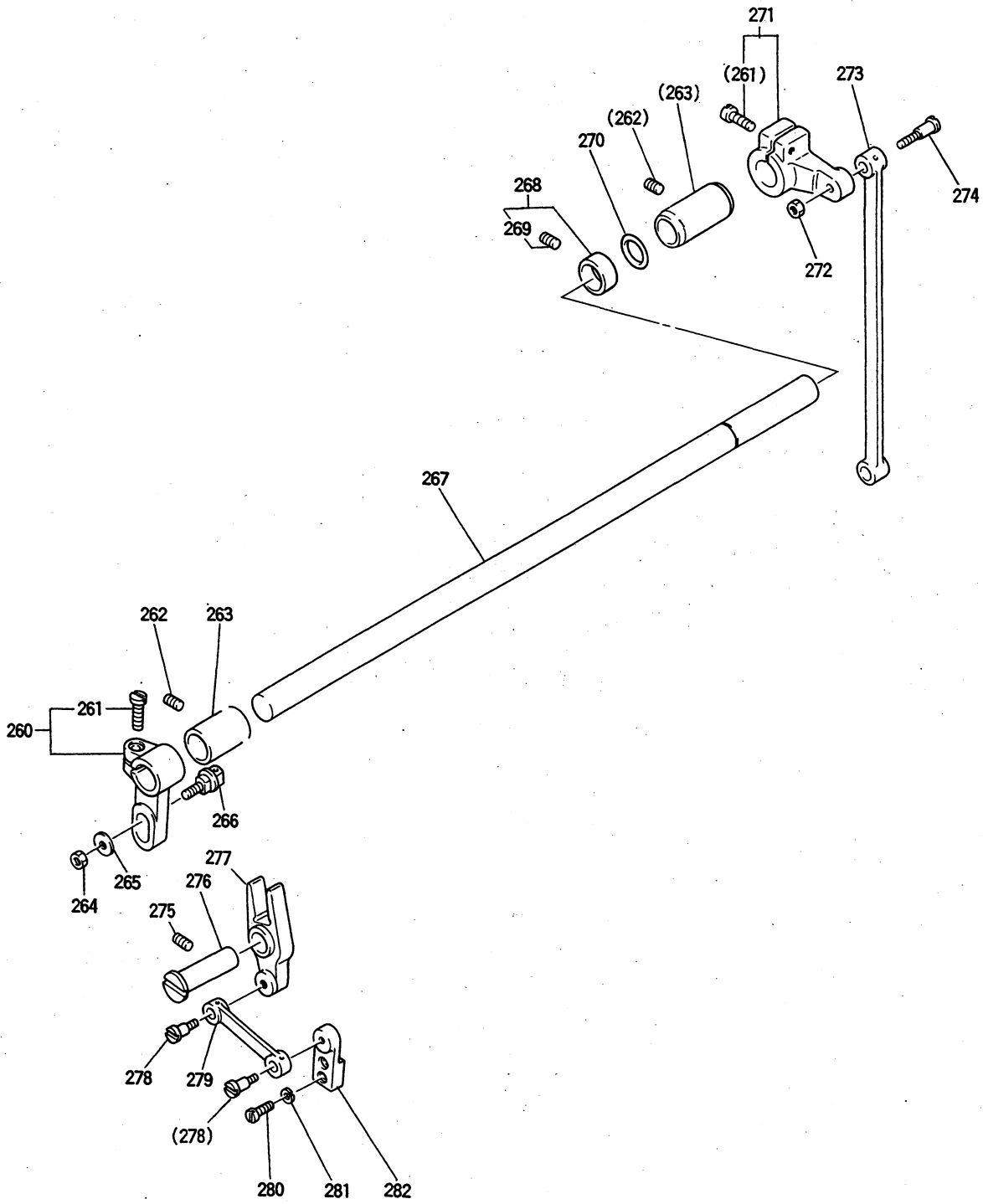

[F] 上部水平送り機構  
UPPER FEED ROCK SHAFT MECHANISM

Fig. No.	変更 Mod	部品コード Parts. No.	部 品 名	Description	使用数 Amt. Req. BOT
F260		MG75E0464	シ ヨウブ スイヘイウテ ヒダ リクミ	Upper feed rock shaft crank (left)	1
F261		M91507002	ヒラネジ	Screw 15/64 (28) x18	2
F262		M91108001	トメネジ	Set screw 11/64 (40) x5.5	2
F263		MG75A0286	オクリジ クメタル	Bushing	2
F264		M91604045	ナット	Nut 1/4 (24)	1
F265		M90607050	ミガキサ ガネ 6	Washer 6	1
F266		MG30E0410	コロサエジ ククミタテ	Feed connecting stick block complete	1
F267		MG75A1491	シ ヨウブ スイヘイオクリジ ク	Upper feed rock shaft	1
F268		MF80A0352	カラークミタテ	Thrust collar with screw	1
F269		M91602001	トメネジ	Set screw 1/4 (40) X4	2
F270		M91200085	Oリング	O-ring S12	1
F271		MG75E0465	シ ヨウブ スイヘイウテ ミギ クミタテ	Upper feed rock shaft crank (right)	1
F272		M91802045	ナット	Nut 9/32 (28)	1
F273		MG75A4956	レンセツカン	Feed drive connecting rod	1
F274		M91803015	ヒラネジ タ ンツキ	Stud screw 9/32 (28) x7	1
F275		M91506001	トメネジ	Set screw 15/64 (28) x7	1
F276		MG75A0530	タ ンツキジ ク	Hinged pin	1
F277		MG75A0950	ヘンカンレバ	Feed connecting lever	1
F278		M91681015	ヒラネジ タ ンツキ	Stud screw 1/4 (40) x5	2
F279		MG75A5956	レンセツカン	Walking foot connecting rod	1
F280		M90910003	マルヒラネジ	Screw 9/64 (40) x7	2
F281		M90304053	ハネサ ガネ 3.5	Spring washer 3.5	2
F282		MG75A1602	トリツカガネ	Feed arm	1

㊦ 上部上下送り機構

UPPER FEED LIFTING ROCK SHAFT MECHANISM

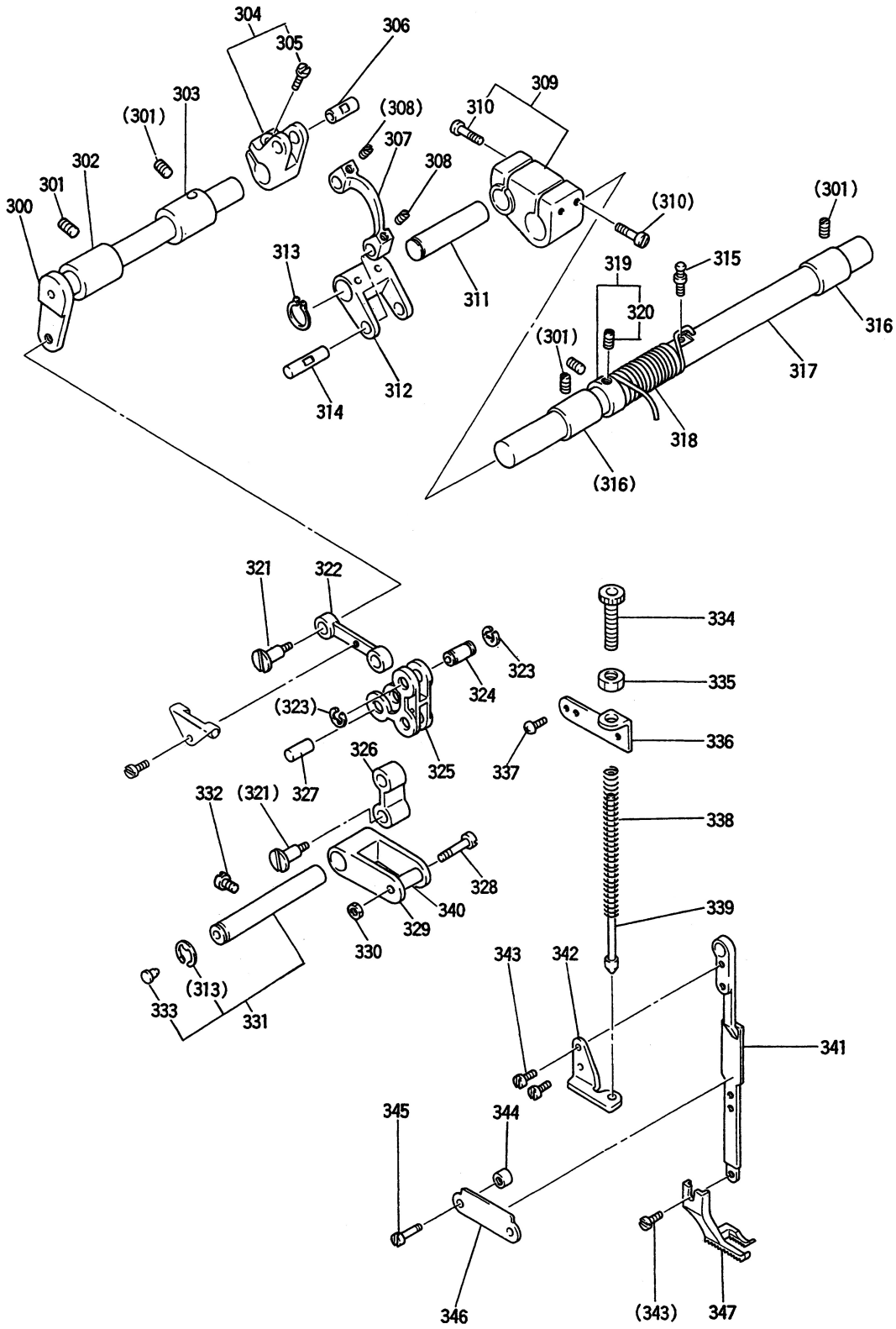



[G] 上部上下送り機構  
UPPER FEED LIFTING ROCK SHAFT MECHANISM

Fig. No.	変更 Mod	部品コード Parts. No.	部 品 名	Description	使用数 Amt. Req. BOT
G300		MG75A0460	ジ ヨウブ ジ ヨウゲ シク	Upper feed lifting rock shaft	1
G301		M91108001	トメネジ	Set screw 11/64 (40) X5.5	4
G302		MG75A1286	ジ ヨウブ ジ ヨウゲ メタル	Bushing for upper feed lifting rock shaft	1
G303		MG75A0287	ジ ヨウブ ジ ヨウゲ メタル	Bushing for upper feed lifting rock shaft	1
G304		MG75E0463	ジ ヨウブ ジ ヨウゲ ウテ ミギ クミタテ	Feed lifting rock shaft crank(right) assy.	1
G305		M91505002	ヒラネジ	Screw 15/64 (28) X13.5	1
G306		MG75A4454	ジク	Upper feed lifting rock crank shaft	1
G307		MG75A6956	レンセツカン	Link	1
G308		M91106001	トメネジ	Set screw 11/64 (40) X3.8	2
G309		MG75E0564	オクリチヨウセツタ イクミタテ	Upper feed regulator bracket	1
G310		M91113002	ヒラネジ	Screw 11/64 (40) X15	4
G311		MG75A5454	ジク	Shaft	1
G312		MG75A2910	リンク	Link	1
G313		M90516065	Cガ タトメワジ クヨウ 10	C-type stop ring 10	2
G314		MG75A6454	ジク	Pin	1
G315		M91508030	トクシユネジ	Screw 15/64 (28) X10	1
G316		MG75A0285	オクリジクメタル	Upper feed shaft bushing	2
G317		MG75A0559	オクリチヨウセツジク	Upper feed regulator shaft	1
G318		MG75A0729	ヒネリバネ	Coil spring	1
G319		MF80A0352	カラークミタテ	Thrust collar assy.	1
G320		M91602001	トメネジ	Set screw 1/4 (40) X4	2
G321		M91681015	ヒラネジ ダンツキ	Hinged screw 1/4 (40) X5	2
G322		MG75A7956	レンセツカン	Feed lifting rock shaft link	1
G323		M90511065	Eガ タトメワ 6	E-type stop ring 6	2
G324		MG75A7454	ジク	Pin	1
G325		MG75A0763	ベルクランク	Bell crank	1
G326		MG75A8956	レンセツカン	Link	1
G327		MG75A8454	ジク	Pin	1
G328		M91522015	ヒラネジ ダンツキ	Stud screw 15/64 (28) X5	1
G329		MG75A0765	ベルクランクササエ	Bell crank supporter	1
G330		M91501045	ナット	Nut 15/64 (28)	1
G331		MG75E0454	ジククミタテ	Bell crank support shaft	1
G332		M91502002	ヒラネジ	Screw 15/64 (28) X12	1
G333		M90573080	セン	Rubber plug φ5.7	1
G334		M91801035	ツマミネジ	Feed regulating screw 9/32 (28) X31	1
G335		M91802045	ナット	Nut 9/32 (28)	1
G336		MG75A0564	オサエチヨウセツタ イ	Presser regulating bracket	1
G337		M91106004	プ ラマイネジ	Screw 11/64 (40) X8	2
G338		MG75A4572	ツルマキバネ	Spring	1
G339		MG75A0154	アンナイガネクミタテ	Spring guide bar complete	1
G340		MG75A0750	ブツシュ	Walking foot guide link bushing	1
G341		MG70A0295	オクリアシササエ	Walking foot guide link	1
G342		MG75A0708	バネカケガネ	Spring holder	1
G343		M90922002	ヒラネジ	Screw 9/64 (40) X8	3
G344		M93009050	ザガネ	Washer	2
G345		M91112002	ヒラネジ	Screw 11/64 (40) X12	2
G346		MG30A0296	ソトオサエアンナイ	Walking foot guide bracket	1
G347		MG10B0294	ソトオサエ	Walking foot	1

# H 押え機構

## PRESSER FOOT MECHANISM

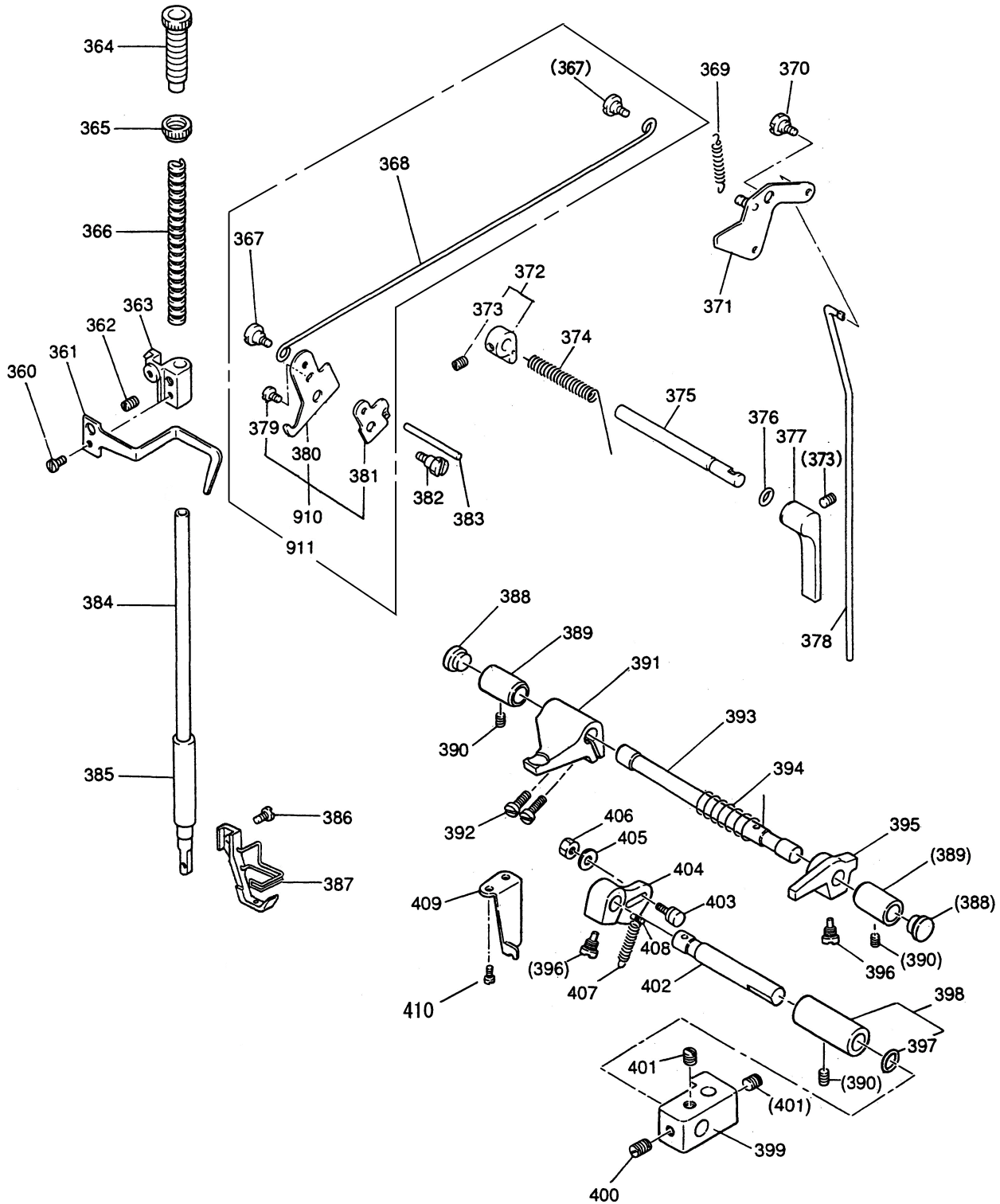

# [H] 押え機構 PRESSER FOOT MECHANISM

Fig. No.	変更 Mod	部品コード Parts. No.	部 品 名	Description	使用数 Amt. Req. BOT
H360		M91109002	ヒラネジ	Screw 11/64 (40) x7	1
H361		MG75A0216	ウワイトアンナイ	Thread guide	1
H362		M91506001	トメネジ	Set screw 15/64 (28) x7	1
H363		MG75A0265	オサエホウダキ	Presser bar guide bracket	1
H364		M93221035	ツマミネジ	Thumb screw 1/2 (28) x43	1
H365		M93202047	トクシユナツト	Nut 1/2 (28)	1
H366		MG75A0259	オサエハネ	Presser bar spring	1
H367		M91219015	ヒラネジ ダンツキ	Stud screw 3/16 (28) X3.5	2
H368		MG75A0738	ヒキボウ	Knee lifter rod	1
H369		MG75A3572	ツルマキハネ	Coil spring	1
H370		M91503031	ボルト	Bolt 15/64 (28) X6.5	1
H371		MG75E0252	オサエアゲレバ - ミキクミタテ	Knee lifter lever assy.	1
H372		MG75E0253	オサエアゲカムクミタテ	Presser bar lifting cam assy.	1
H373		M91503001	トメネジ	Set screw 15/64 (28) x4.5	2
H374		MG75A1729	ヒネリハネ	Coil spring	1
H375		MG75A9454	オサエアゲジク	Presser foot lifting shaft	1
H376		M90500085	オリング	O-ring 1AP5	1
H377		MG75A0252	オサエアゲレバ	Presser bar lifter	1
H378		MG70A0511	ソウサホウ	Knee lifter connecting rod	1
H379		M91131002	ヒラネジ	Screw 11/64 (40) X6.5	1
H380		—	オサエアゲレバ - ヒダリ	Knee lifter lever (left)	1
H381		—	イトユルメカム	Tension releasing cam	1
H382		M91504031	ダンツキボルト	Stud Bolt 15/64 (28) X7	1
H383		M90423060	イトユルメピン	Thread releasing pin	1
H384		MG75A0262	オサエホウ	Presser bar	1
H385		MF00A0267	オサエホウメタル	Bushing for presser bar busing	1
H386		M90922002	ヒラネジ	Screw 9/64 (40) x8	1
H387		MG50E0256	ウチオサエクミタテ	Presser foot assy.	1
H388		M91305080	セン	Rubber plug φ13	2
H389		MG70A0833	ヒサアゲメタル	Knee lifter shaft bushing	2
H390		M91108001	トメネジ	Set screw 11/65 (40) X5.5	3
H391		MG70A2252	オサエアゲウデ	Presser bar lifting crank	1
H392		M91505002	ヒラネジ	Screw 15/64 (28) X13.5	2
H393		MG70A3511	ソウサホウ	Knee lifter connecting rod	1
H394		MG70A0729	ヒネリハネ	Coil spring	1
H395		MG70A0252	オサエアゲウデ	Presser bar lifting crank	1
H396		M91802006	ヒラネジホウサキ	Screw 9/32 (28) X14	2
H397		M91203085	オリング	O-ring 1A P12.5	1
H398		MG70E0833	ヒサアゲメタルクミタテ	Knee lifter shaft bushing assy.	1
H399		MG70A1591	ツキテ	Knee lifter crank	1
H400		M98001020	ロツカクアナツキトメネジ	Soket set screw M8X12	1
H401		M98002020	アナツキトメネジ	Screw M8X8	2
H402		MG70A4511	ソウサホウ	Knee lifter connecting rod	1
H403		MG70E0410	コロササエジククミタテ	Feed connecting stick block assy.	1
H404		MG70A1252	オサエアゲウデ	Presser bar lifting crank	1
H405		M90607050	ミガキザガネ 6	Washer 6	1
H406		M91604045	ナツト	Nut 1/4 (24)	1
H407		MG70A1572	ツルマキハネ	Coil spring	1
H408		M90421063	カシメピン	Pin	1
H409		MG70A2361	カケガネ	Spring holder	1
H410		M91109004	ザガネツキブラマイネジ	Screw 11/64 (40) X8	2
H910		MG75E1252	オサエアゲレバ - ヒダリクミタテ	Knee lifter lever (left) assy.	1
H911		MG75E2252	オサエアゲレバ - ヒダリクミタテ	Knee lifter lever (left) assy.	1

□ タッチバック機構および検出器機構

TOUCH BACK MECHANISM & DETECTOR MECHANISM

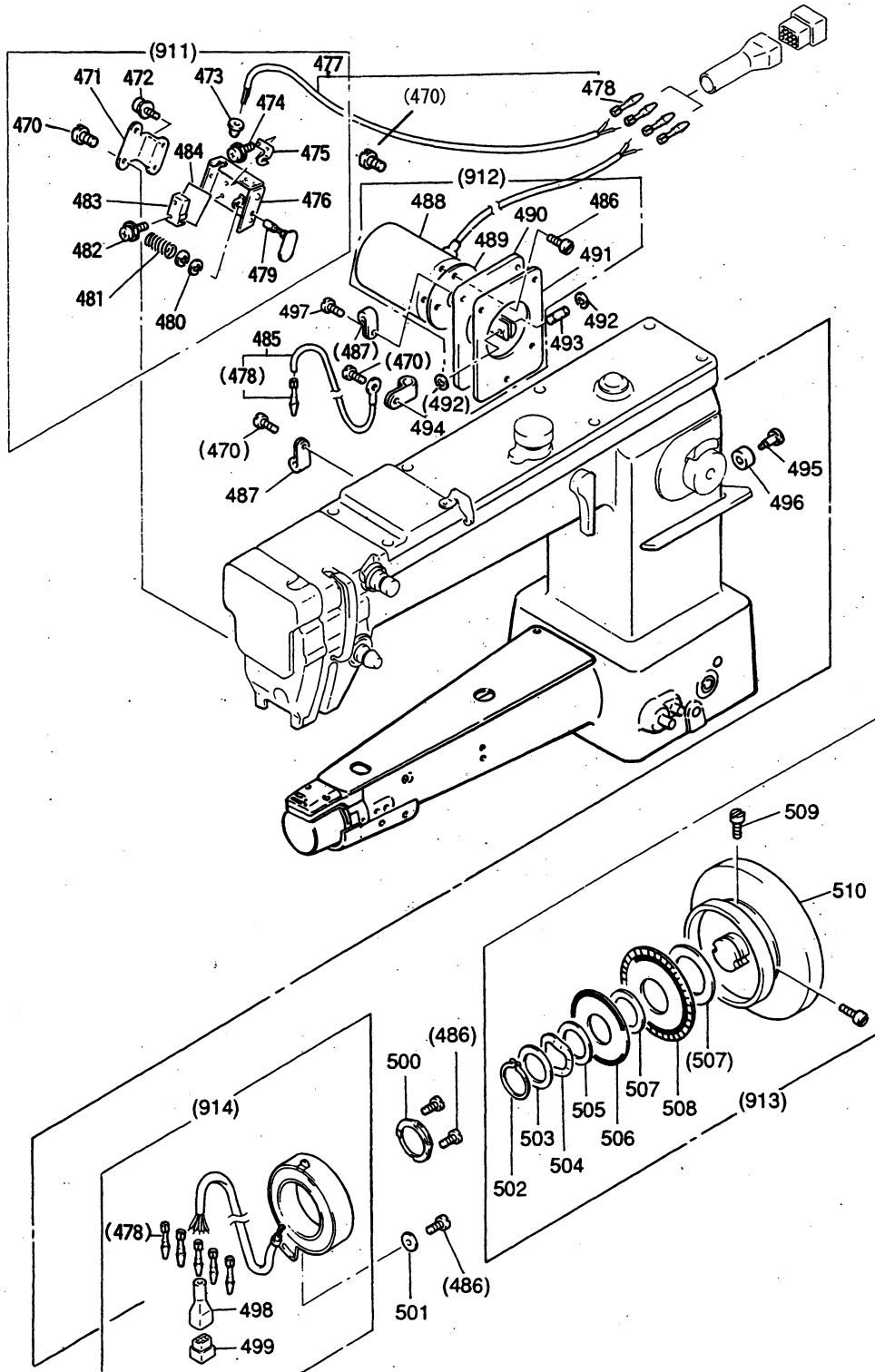

[J] タッチバック機構および検出器機構  
TOUCH BACK MECHANISM & DETECTOR MECHANISM

Fig. No.	変更 Mod	部品コード Parts. No.	部 品 名	Description	使用数 Amt. Req. BOT
J470		M91109004	ザガネツキフ ラマイネジ	Screw 11/64 (40) X8	8
J471		MG75A0601	トリツケイタ	Bracket	1
J472		M90309037	SW-PWツキ Pナベネジ	Screw M3X5	2
J473		M91004080	ゴムフ ツシュ	Rubber plug	1
J474		M90201037	Pナベネジ	Screw M2X3	2
J474		M90315050	コサガネ	Washer 2	2
J474		M90306053	ハネサガネ	Spring washer 2	2
J475		MF00A0192	イタハネ	Plate spring	1
J476		MG75A1601	スイッチトリツケイタ	Bracket for touch switch	1
J477		M97070095	コードクミタテ	Cord assy.	1
J478		M93003099	ピン 1380TL	Terminal pin	10
J479		MF00A0270	押しボタン	Push button	1
J480		M90512065	Eタイプメウ 3	E-type stop ring 3	2
J481		MF00A7572	ツルマキハネ	Coil spring	1
J482		M90251037	Pハインドネジ	Screw M2X8	2
J483		M90208099	マイクロスイッチ	Micro switch	1
J484		MF01A0502	セツエンイタ	Insulator seat	1
J485		M97003095	アースセンクミタテ	Ground wire assy.	1
J486		M91106004	フ ラマイネジ	Screw 11/64 (40) x8	7
J487		M94003099	ナイロンクリツフ	Cord holder	2
J488		M91021095	ソレノイド	Solenoid	1
J489		MF01A0691	ガスケット	Gasket	1
J490		MG75A1880	ヨコブター2	Arm side cover-2	1
J491		MG75A2691	ガスケット	Gasket	1
J492		M90504065	Eタイプメウ 4	E-type stop ring 4	2
J493		M90516063	ピン	Pin	1
J494		MB60A1620	ナイロンクリツフ	Cord holder	1
J495		MG70A1426	ササエ	Stud screw	1
J496		MN36A0417	ゴムウ	Rubber cushion	1
J497		M91111004	フ ラマイネジ	Screw 11/64 (40) x10	1
J498		MG68A0366	コネクタキーヤツフ	Connector cap	1
J499		M91018099	コネクタ	Nylon connector	1
J500		MF01A0257	オサエイタ	Detector bracket supporter	1
J501		M93002050	ザガネ	Washer 12	1
J502		M90330065	Cタイプメウ	Retaining ring-C type 30	1
J503		M93001050	ザガネ	Washer 30	1
J504		MF01A0259	ハンデンイタオサエスプリング	Supporter spring	1
J505		MF01A1476	スペーサ B	Spacer B	1
J506		MF01A1694	ハンシャパン B21	Speed command disc B21 (up)	1
J507		MF01A0476	スペーサ A	Spacer A	2
J508		MF01A0694	ハンシャパン B12	Speed command disc B12 (down)	1
J509		M91502002	ヒラネジ	Set screw 15/64 (28) X12	2
J510		MG75A0682	プリー	Pulley	1
J911		MG75E0534	タッチスイッチクミタテ	Touch switch assy.	1
J912		MG75E3519	ヨコブターソレノイドクミタテ	Arm side cover solenoid assy.	1
J913		MG75E0682	プリークミタテ	Pulley assy.	1
J914		ME20A0406	ケンユツクミタテ (センサー)	Detector bracket assy. (sensor)	1



**[K] 給油機構**  
**OIL LUBRICATION MECHANISM**

Fig. No.	変更 Mod	部品コード Parts. No.	部 品 名	Description	使用数 Amt. Req. BOT
K520		MF00A2780	ホルダ	Holder	1
K521		MG70E0688	パイプクミタテ	Oil return tube assy.	1
K522		M90906002	ヒラネジ	Screw 9/64(40)X4.5	1
K523		MG75A0780	ホルダ	Holder	1
K524		MN70E1148	ヒモ	Oil wick φ2Dx370	1
K525		MF01A2740	フェルト	Felt	1
K526		MN70E1148	ヒモ	Oil wick φ2Dx135	1
K527		M90805002	ヒラネジ	Screw 1/8(44)X4.8	1
K528		MN40A0705	ハネオサエ	Guide plate	1
K529		MN40A1572	ツルマキハネ	Spring	1
K530		M95007063	トクシユピン	Pin	1
K531		MG70A0688	パイプ	Oil pipe	2
K532		MN60A0620	ナイロンクリップ	Cord holder	1
K533		M91113002	ヒラネジ	Screw 11/64(40)X15	1
K534		MF01A0378	ホルマクリップ 5	Holder for oil braid 5	12
K535		MG70A1688	パイプ	Pipe	2
K536		MG70E0601	トリツケイタクミタテ	Bracket assy.	1
K537		M91106004	フランマイネジ	Screw 11/64(40)X8	6
K538		MP60A0337	フィルタ	Filter assy.	1
K539		M90944003	マルヒラネジ	Screw 9/64(40)X5	2
K540		MG70A1780	ホルダ	Holder	1
K541		MF00A0753	プランジャー	Plunger	3
K542		MF00A0572	ツルマキハネ	Spring	3
K543		MG70A1154	アンナイタ	Guide plate	1
K544		MG70A0154	アンナイタ	Guide plate	1
K545		MG70A2780	ホルダ	Holder	1
K546		MG70A0740	フェルト	Felt	1
K547		M90604002	ヒラネジ	Screw 3/32(56)X2.4	1
K548		MG70A0148	ヒモ	Oil wick φ2.5x190	1
K549		MG70A0690	パイプオサエ	Holder	1
K550		MG70A1601	トリツケイタ	Oil pump fitting plate	1
K551		M90906003	マルヒラネジ	Screw 9/64(40)X3.2	1
K552		MV11A0148	ヒモ	Oil wick φ2.5x150	1
K553		M90300085	リング	O-ring P-3	1
K554		M94005030	チヨウセツネジ	Oil adjusting screw	1
K555		MG70A0780	ホルダ	Holder	1
K556		M90602002	ヒラネジ	Screw 3/32(56)X3	1
K557		MG70A3688	パイプ	Oil pipe	1
K558		M90939002	ヒラネジ	Screw 9/64(40)X11	4
K559		MG70E0564	チヨウセツタイクミタテ	Oil adjusting bracket	1
K560		MG70A2688	パイプ	Oil pipe	1
K561		MG70E1740	フェルトクミタテ	Felt assy.	1
K562		MG70A4688	パイプ	Oil pipe	1

☐ 付属品  
ACCESSORIES

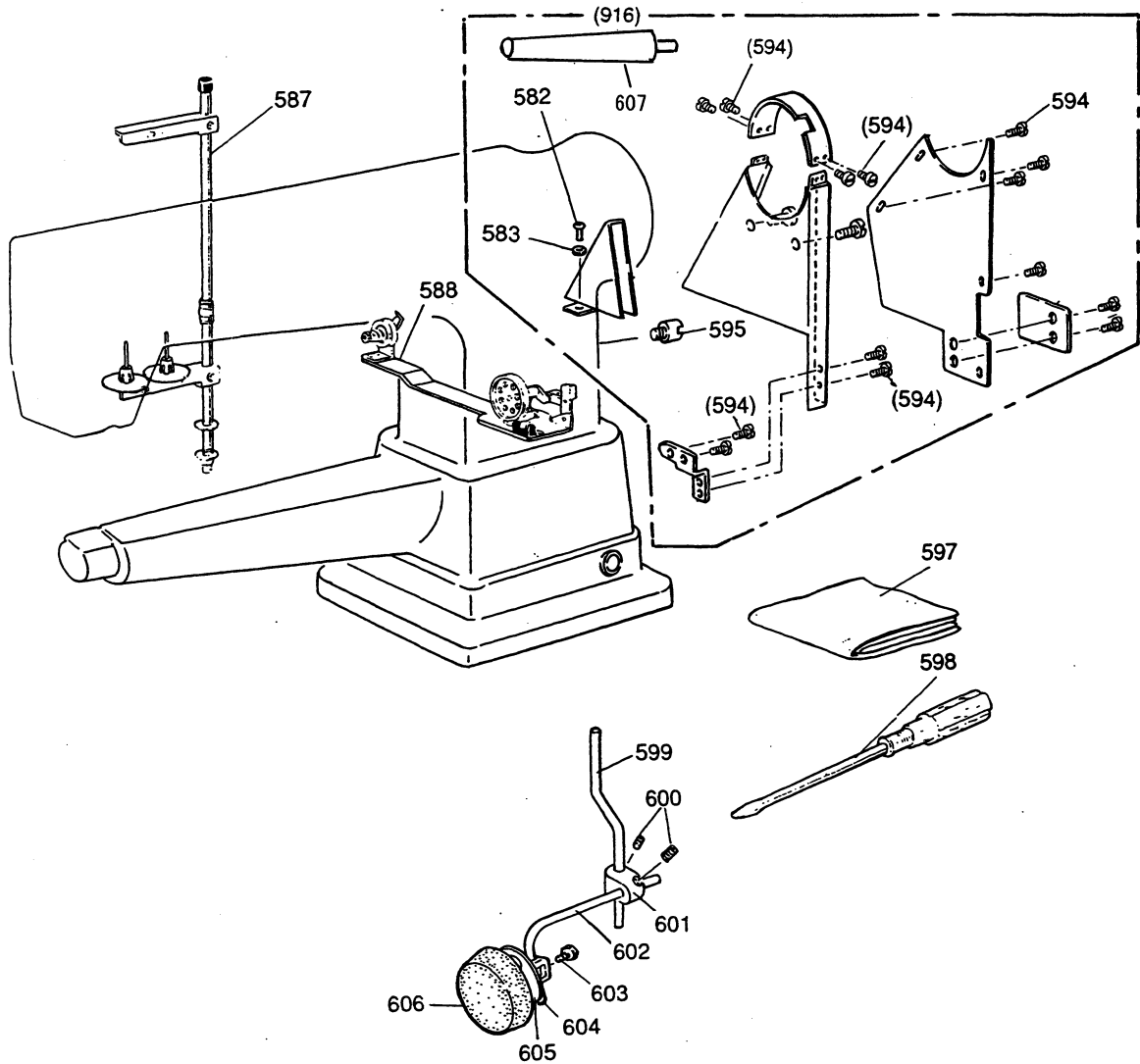
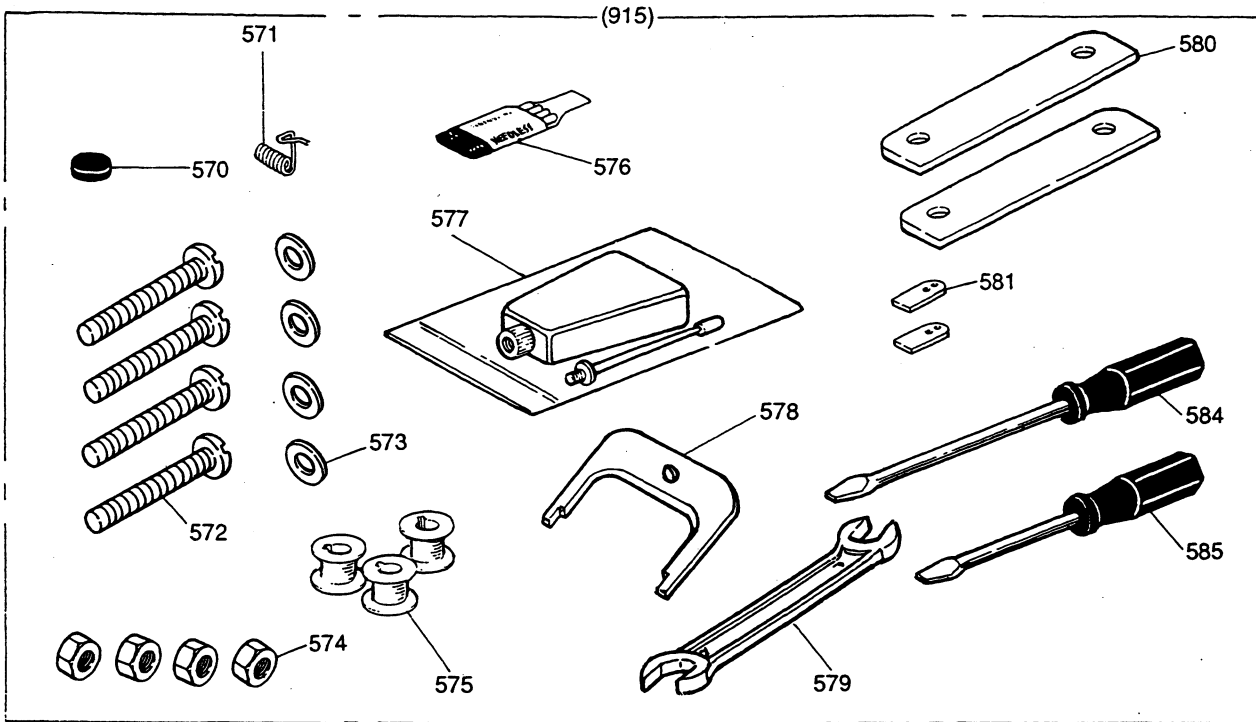



[L] 付属品  
ACCESSORIES

Fig. No.	変更 Mod	部品コード Parts. No.	部 品 名	Description	使用数 Amt. Req. BOT
L570		M90701099	OP-S ジンヤク	Magnet block for reservoir	1
L571		MF83A1187	イトリハネ	Thread take-up spring	1
L572		M95000004	スリワリツキコネジ	Bolt M8X65	4
L573		M90816050	ミガキサガネ 8	Washer 8	4
L574		M92008045	ナット	Nut M8	4
L575		MF25B0123	ホビン	Bobbin	3
L576		MG37A0128	ミシンハリ DPX17-22	Needle DPX17 #22	4
L577		MF60A0137	アブラサシ	Oil with oiler	1
L578		MF01A0565	カクトチヨウセイク	Speed command disc adjusting plate	1
L579		MM10A1479	スパナ マルカタ	Spanner	1
L580		MG70A1419	ホウシヨクム	Vibration preventing rubber	2
L581		MG70A0476	スペーサ	Spacer	2
L582		M90409041	マルモクネジ 4.5X20	Screw 4.5X20	4
L583		M90511050	ミガキサガネ 5	Washer M5	4
L584		MF06A0608	ネジ マワシ (チュウ)	Screw driver (middle)	1
L585		MF06A1608	ネジ マワシ (ショウ)	Screw driver (small)	1
L587		MH10E0193	イトタテダ イセツト	Thread stand assy	1
L588		MF08E0190	イトマキシカケ	Bobbin winder complete	1
L594		M91120004	サガネツキ プラマイネジ	Screw 11/64 (40) X6.5	17
L595		MG70A0426	ササエ	Leg	1
L596		MG70A0429	ササエイタ	Bracket	1
L597		MP60A0734	ビニールカバー	Vinyl cover	1
L598		MF00A0608	ネジ マワシ (ダイ)	Screw driver (large)	1
L599		MG70A2511	ソウサホウ	Knee lifter shaft	1
L600		M98002020	アナツキトメネジ	Screw M8X8	2
L601		MG70A0591	ツキテ	Elbow joint	1
L602		MG70A1511	ソウサホウ	Knee lifter connecting rod	1
L603		M91510022	ボルト	Bolt 15/64 (28) X8	1
L604		MF40A0477	ストツパ	Knee lifter plate stopper	1
L605		MF40A0737	ヒザアテイタ	Knee lifter plate	1
L606		MF40A1737	ヒザアテ	Knee lifter cover	1
L607		MA08A0613	トウフササエ	Head Rest	1
L915		MG70E0749	フゾクヒンバコセット	Accessories box set	1
L916		MG70E0776	ベルトカバーセット	Belt cover assy.	1

索引 ( I )  
INDEX ( I )

部品コード	ページ	Fig	部品コード	ページ	Fig	部品コード	ページ	Fig
Parts. No.	Page	No.	Parts. No.	Page	No.	Parts. No.	Page	No.
M90105054	P3	A04	M90944003	P21	K539	M91503031	P17	H370
M90201037	P19	J474	M91000085	P11	E229	M91504031	P17	H382
M90208099	P19	J483	M91004080	P19	J473	M91505002	P15	G305
M90228060	P5	B43	M91018099	P19	J499	M91505002	P17	H392
M90251037	P19	J482	M91021095	P19	J488	M91506001	P7	C103
M90300085	P21	K553	M91070003	P5	B73	M91506001	P11	E213
M90304053	P13	F281	M91101046	P5	B35	M91506001	P13	F275
M90306053	P19	J474	M91102011	P5	B68	M91506001	P17	H362
M90309037	P19	J472	M91106001	P9	D181	M91507002	P9	D144
M90310064	P9	D188	M91106001	P15	G308	M91507002	P13	F261
M90315050	P19	J474	M91106003	P5	B71	M91508001	P3	A32
M90330065	P19	J502	M91106004	P3	A36	M91508004	P3	A03
M90402085	P7	C123	M91106004	P7	C90	M91508030	P15	G315
M90409041	P23	L582	M91106004	P11	E209	M91510002	P3	A29
M90421063	P17	H408	M91106004	P11	E247	M91510022	P23	L603
M90423060	P17	H383	M91106004	P15	G337	M91513001	P7	C87
M90431060	P3	A12	M91106004	P19	J486	M91513001	P7	C114
M90500085	P17	H376	M91106004	P21	K537	M91513001	P11	E204
M90504065	P11	E215	M91108001	P3	A28	M91515002	P11	E238
M90504065	P19	J492	M91108001	P9	D139	M91516002	P9	D143
M90511050	P23	L583	M91108001	P9	D173	M91516002	P11	E219
M90511065	P15	G323	M91108001	P11	E203	M91521002	P9	D147
M90512065	P19	J480	M91108001	P13	F262	M91522015	P15	G328
M90516063	P19	J493	M91108001	P15	G301	M91525015	P5	B60
M90516065	P15	G313	M91108001	P17	H390	M91602001	P7	C105
M90573080	P3	A02	M91109002	P3	A09	M91602001	P7	C124
M90573080	P15	G333	M91109002	P17	H360	M91602001	P9	D141
M90600085	P11	E242	M91109004	P3	A05	M91602001	P11	E201
M90602002	P21	K556	M91109004	P17	H410	M91602001	P13	F269
M90604002	P21	K547	M91109004	P19	J470	M91602001	P15	G320
M90607050	P13	F265	M91110001	P9	D151	M91604045	P13	F264
M90607050	P17	H405	M91111001	P9	D145	M91604045	P17	H406
M90614002	P9	D195	M91111004	P19	J497	M91604080	P3	A33
M90700085	P7	C96	M91112002	P15	G345	M91606001	P7	C94
M90700085	P11	E227	M91112004	P3	A18	M91610001	P7	C110
M90701099	P23	L570	M91113002	P15	G310	M91610046	P5	B49
M90707065	P9	D177	M91113002	P21	K533	M91681015	P13	F278
M90740080	P7	C119	M91118002	P11	E224	M91681015	P15	G321
M90805002	P21	K527	M91120004	P23	L594	M91687015	P9	D133
M90807002	P9	D193	M91131002	P17	H379	M91801002	P7	C95
M90811060	P3	A34	M91136002	P9	D187	M91801035	P15	G334
M90815002	P7	C85	M91142015	P9	D167	M91802006	P7	C97
M90815002	P9	D171	M91182080	P5	B72	M91802006	P17	H396
M90816050	P23	L573	M91190003	P9	D183	M91802045	P13	F272
M90819060	P3	A35	M91191003	P9	D166	M91802045	P15	G335
M90821002	P9	D163	M91200085	P13	F270	M91803015	P13	F274
M90883080	P3	A01	M91203002	P9	D130	M91910080	P3	A08
M90883080	P7	C80	M91203085	P17	H397	M92002002	P5	B55
M90901002	P5	B50	M91207003	P11	E237	M92004001	P9	D180
M90904063	P11	E211	M91215002	P9	D135	M92004080	P11	E210
M90906002	P5	B51	M91215002	P11	E236	M92008045	P23	L574
M90906002	P5	B75	M91219015	P17	H367	M92200080	P3	A21
M90906002	P21	K522	M91259030	P9	D158	M92204030	P9	D164
M90906003	P21	K551	M91305080	P17	H388	M92601080	P3	A23
M90906010	P5	B62	M91472086	P7	C109	M92900080	P3	A22
M90908003	P3	A30	M91501007	P11	E244	M93001050	P19	J503
M90910003	P13	F280	M91501045	P15	G330	M93002050	P19	J501
M90911010	P5	B54	M91501085	P5	B40	M93003099	P19	J478
M90922002	P15	G343	M91502002	P15	G332	M93009050	P15	G344
M90922002	P17	H386	M91502002	P19	J509	M93202047	P17	H365
M90939002	P21	K558	M91503001	P17	H373	M93221035	P17	H364

索引 (Ⅱ)  
INDEX (Ⅱ)

部品コード	ページ	Fig	部品コード	ページ	Fig	部品コード	ページ	Fig
Parts. No.	Page	No.	Parts. No.	Page	No.	Parts. No.	Page	No.
M93600085	P11	E222	MF10A0555	P5	B45	MG70A0500	P3	A25
M94003099	P19	J487	MF10A0709	P5	B41	MG70A0511	P17	H378
M94005030	P21	K554	MF10A1555	P5	B37	MG70A0520	P7	C115
M94006021	P3	A13	MF20A0135	P3	A17	MG70A0572	P9	D168
M95000004	P23	L572	MF25B0123	P9	D160	MG70A0591	P23	L601
M95003053	P11	E240	MF25B0123	P23	L575	MG70A0600	P3	A19
M95007063	P21	K530	MF36A0245	P5	B36	MG70A0603	P5	B65
M95010063	P9	D185	MF40A0477	P23	L604	MG70A0606	P9	D190
M97001052	P5	B56	MF40A0737	P23	L605	MG70A0660	P7	C82
M97003095	P19	J485	MF40A1737	P23	L606	MG70A0688	P21	K531
M97006060	P7	C907	MF60A0137	P23	L577	MG70A0690	P21	K549
M97013060	P9	D142	MF60A0663	P7	C81	MG70A0691	P5	B52
M97070095	P19	J477	MF70A0750	P11	E212	MG70A0729	P17	H394
M98001020	P17	H400	MF74B0522	P7	C116	MG70A0740	P21	K546
M98002020	P17	H401	MF80A0352	P7	C104	MG70A0761	P9	D174
M98002020	P23	L600	MF80A0352	P9	D140	MG70A0780	P21	K555
MA08A0613	P23	L607	MF80A0352	P11	E200	MG70A0833	P17	H389
MB60A1620	P19	J494	MF80A0352	P13	F268	MG70A0841	P3	A14
ME20A0406	P19	J914	MF80A0352	P15	G319	MG70A1101	P5	B67
MF00A0181	P5	B39	MF83A1187	P23	L571	MG70A1104	P9	D161
MF00A0192	P19	J475	MF85A0640	P11	E230	MG70A1154	P21	K543
MF00A0257	P11	E235	MF90A0553	P5	B38	MG70A1192	P9	D194
MF00A0267	P17	H385	MG10B0294	P15	G347	MG70A1250	P3	A24
MF00A0270	P19	J479	MG30A0296	P15	G346	MG70A1252	P17	H404
MF00A0572	P21	K542	MG30E0410	P13	F266	MG70A1257	P9	D192
MF00A0608	P23	L598	MG37A0128	P7	C86	MG70A1273	P9	D134
MF00A0633	P11	E241	MG37A0128	P23	L576	MG70A1325	P9	D172
MF00A0753	P21	K541	MG42A0181	P7	C84	MG70A1339	P5	B69
MF00A0852	P11	E226	MG43A0181	P3	A31	MG70A1361	P11	E246
MF00A0950	P11	E232	MG43A1181	P5	B70	MG70A1419	P23	L580
MF00A2708	P11	E221	MG44E0125	P9	D908	MG70A1426	P19	J495
MF00A2780	P21	K520	MG44E0662	P7	C92	MG70A1491	P9	D175
MF00A7572	P19	J481	MG50E0256	P17	H387	MG70A1511	P23	L602
MF00E0550	P5	B902	MG52A0245	P5	B47	MG70A1572	P17	H407
MF00E1635	P11	E243	MG61A0361	P5	B59	MG70A1591	P17	H399
MF01A0257	P19	J500	MG68A0366	P19	J498	MG70A1601	P21	K550
MF01A0259	P19	J504	MG70A0101	P5	B66	MG70A1603	P9	D186
MF01A0378	P21	K534	MG70A0104	P9	D162	MG70A1631	P3	A15
MF01A0476	P19	J507	MG70A0148	P21	K548	MG70A1688	P21	K535
MF01A0502	P19	J484	MG70A0154	P21	K544	MG70A1750	P9	D155
MF01A0565	P23	L578	MG70A0192	P9	D170	MG70A1760	P9	D189
MF01A0632	P11	E239	MG70A0250	P5	B58	MG70A1780	P21	K540
MF01A0691	P19	J489	MG70A0252	P17	H395	MG70A1956	P9	D132
MF01A0694	P19	J508	MG70A0257	P9	D191	MG70A2252	P17	H391
MF01A0740	P7	C88	MG70A0273	P9	D179	MG70A2273	P9	D131
MF01A1476	P19	J505	MG70A0279	P9	D138	MG70A2339	P5	B53
MF01A1694	P19	J506	MG70A0281	P9	D165	MG70A2361	P17	H409
MF01A1740	P7	C121	MG70A0285	P9	D137	MG70A2511	P23	L599
MF01A2740	P21	K525	MG70A0295	P15	G341	MG70A2572	P11	E249
MF02A0187	P5	B42	MG70A0325	P9	D176	MG70A2603	P9	D169
MF02A0245	P11	E231	MG70A0339	P5	B63	MG70A2688	P21	K560
MF02A0553	P5	B44	MG70A0361	P11	E248	MG70A2780	P21	K545
MF03A0417	P7	C89	MG70A0411	P9	D178	MG70A3511	P17	H393
MF03A0584	P3	A27	MG70A0416	P5	B64	MG70A3688	P21	K557
MF03A0841	P11	E234	MG70A0419	P5	B57	MG70A4511	P17	H402
MF05A0572	P11	E225	MG70A0426	P23	L595	MG70A4688	P21	K562
MF05A0740	P9	D157	MG70A0429	P23	L596	MG70E0120	P9	D159
MF06A0608	P23	L584	MG70A0450	P9	D153	MG70E0230	P7	C120
MF06A1608	P23	L585	MG70A0451	P9	D156	MG70E0234	P7	C102
MF08E0190	P23	L588	MG70A0476	P9	D184	MG70E0297	P11	E909
MF10A0325	P7	C91	MG70A0476	P23	L581	MG70E0330	P7	C904

索引 (Ⅲ)  
INDEX (Ⅲ)

部品コード	ページ	Fig	部品コード	ページ	Fig	部品コード	ページ	Fig
Parts. No.	Page	No.	Parts. No.	Page	No.	Parts. No.	Page	No.
MG70E0352	P9	D182	MG75A1491	P13	F267			
MG70E0383	P7	C93	MG75A1572	P11	E245			
MG70E0410	P17	H403	MG75A1601	P19	J476			
MG70E0453	P9	D154	MG75A1602	P13	F282			
MG70E0491	P9	D136	MG75A1691	P3	A20			
MG70E0560	P5	B61	MG75A1729	P17	H374			
MG70E0564	P21	K559	MG75A1830	P5	B74			
MG70E0580	P7	C903	MG75A1880	P19	J490			
MG70E0601	P21	K536	MG75A1910	P11	E217			
MG70E0688	P21	K521	MG75A2454	P11	E206			
MG70E0749	P23	L915	MG75A2691	P19	J491			
MG70E0760	P7	C107	MG75A2910	P15	G312			
MG70E0776	P23	L916	MG75A2956	P7	C106			
MG70E0833	P17	H398	MG75A3454	P11	E218			
MG70E1330	P7	C905	MG75A3572	P17	H369			
MG70E1352	P9	D152	MG75A3956	P9	D148			
MG70E1740	P21	K561	MG75A4454	P15	G306			
MG75A0152	P11	E220	MG75A4572	P15	G338			
MG75A0154	P15	G339	MG75A4956	P13	F273			
MG75A0180	P3	A10	MG75A5454	P15	G311			
MG75A0216	P17	H361	MG75A5956	P13	F279			
MG75A0232	P7	C98	MG75A6454	P15	G314			
MG75A0233	P7	C108	MG75A6956	P15	G307			
MG75A0252	P17	H377	MG75A7454	P15	G324			
MG75A0259	P17	H366	MG75A7956	P15	G322			
MG75A0262	P17	H384	MG75A8454	P15	G327			
MG75A0265	P17	H363	MG75A8956	P15	G326			
MG75A0285	P11	E202	MG75A9454	P17	H375			
MG75A0285	P15	G316	MG75E0210	P5	B901			
MG75A0286	P13	F263	MG75E0252	P17	H371			
MG75A0287	P15	G303	MG75E0253	P17	H372			
MG75A0291	P3	A26	MG75E0321	P11	E207			
MG75A0417	P7	C122	MG75E0454	P15	G331			
MG75A0454	P9	D150	MG75E0463	P15	G304			
MG75A0460	P15	G300	MG75E0464	P13	F260			
MG75A0521	P7	C113	MG75E0465	P13	F271			
MG75A0530	P13	F276	MG75E0492	P7	C99			
MG75A0559	P15	G317	MG75E0534	P19	J911			
MG75A0564	P15	G336	MG75E0564	P15	G309			
MG75A0572	P3	A11	MG75E0633	P11	E228			
MG75A0601	P19	J471	MG75E0682	P19	J913			
MG75A0602	P11	E205	MG75E0693	P7	C101			
MG75A0603	P11	E223	MG75E1252	P17	H910			
MG75A0631	P11	E233	MG75E2252	P17	H911			
MG75A0664	P7	C83	MG75E3519	P19	J912			
MG75A0682	P19	J510	MH10E0193	P23	L587			
MG75A0691	P3	A07	MH40A0556	P5	B46			
MG75A0708	P15	G342	MM10A1479	P23	L579			
MG75A0729	P15	G318	MN36A0417	P19	J496			
MG75A0738	P17	H368	MN40A0325	P9	D146			
MG75A0750	P15	G340	MN40A0705	P21	K528			
MG75A0763	P15	G325	MN40A1572	P21	K529			
MG75A0765	P15	G329	MN45A0154	P11	E208			
MG75A0780	P21	K523	MN60A0620	P21	K532			
MG75A0880	P3	A06	MN70E1148	P21	K524			
MG75A0910	P11	E216	MN70E1148	P21	K526			
MG75A0950	P13	F277	MP60A0337	P21	K538			
MG75A0956	P7	C100	MP60A0734	P23	L597			
MG75A1286	P15	G302	MQ50A0181	P5	B76			
MG75A1454	P9	D149	MT60A0802	P5	B48			
MG75A1476	P11	E214	MV11A0148	P21	K552			







# 名菱テクニカ株式会社

お問い合わせは下記へどうぞ

縫製機械事業部 縫製営業部 〒488-0052 愛知県尾張旭市下井町下井 2039-1

代表電話番号 (0561)51-1231 代表FAX番号 (0561)51-1212