

三菱工業用ミシン部品カタログ

Industrial Sewing Machine Parts Catalog

Model LU2-4652-B1T

目次	CONTENTS	Page
A 本体関係	Body & it's accessories	2
B 糸調節器部分	Thread tension regulator mechanism	4
C 上軸機構	Upper shaft mechanism	6
D 針棒・天秤機構	Needle bar & thread take-up lever mechanism	8
E 上部上下送り・押え機構	Upper feed lifting rock shaft mechanism	10
F 押え機構	Presser foot mechanism	12
G 縫目加減機構	Stitch regulator mechanism	14
H 下軸・送り機構	Lower shaft & feed rocking motion mechanism	16
J カマ台機構	Hook saddle mechanism	18
K 糸切り機構 (I)	Thread trimming mechanism (I)	20
L 糸切り機構 (II)	Thread trimming mechanism (II)	22
M 制御装置部分	Control device components	24
N 給油機構	Oil lubrication mechanism	26
P 付属品	Accessories	28
索引	Index	30
オプションパーツ	Option parts	33

ミシン部品コードの採番基準

SPARE PARTS No. Designation system

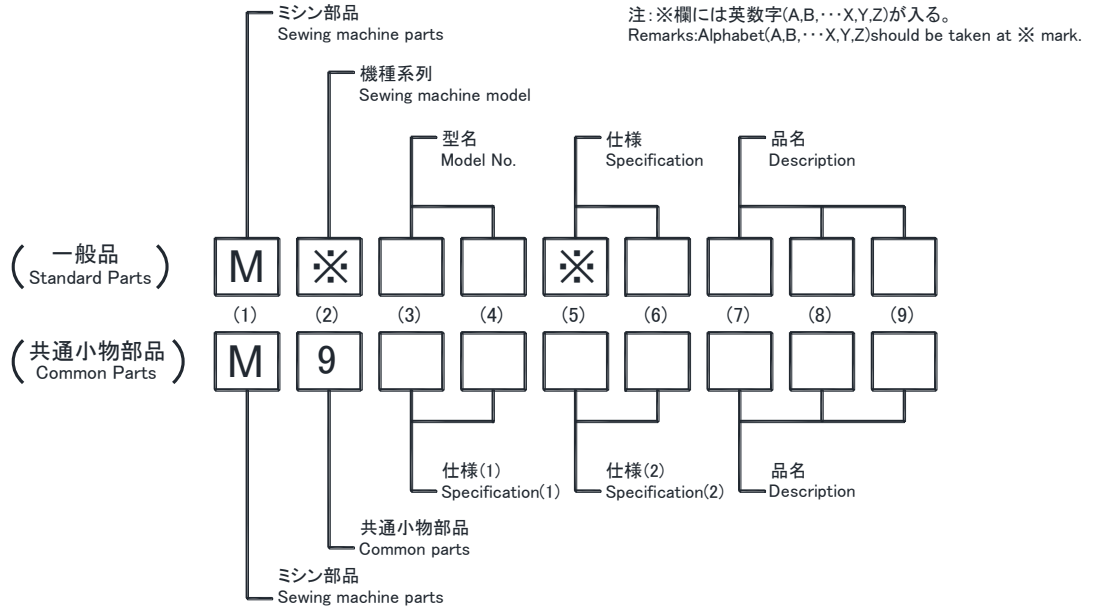

[例]
Example

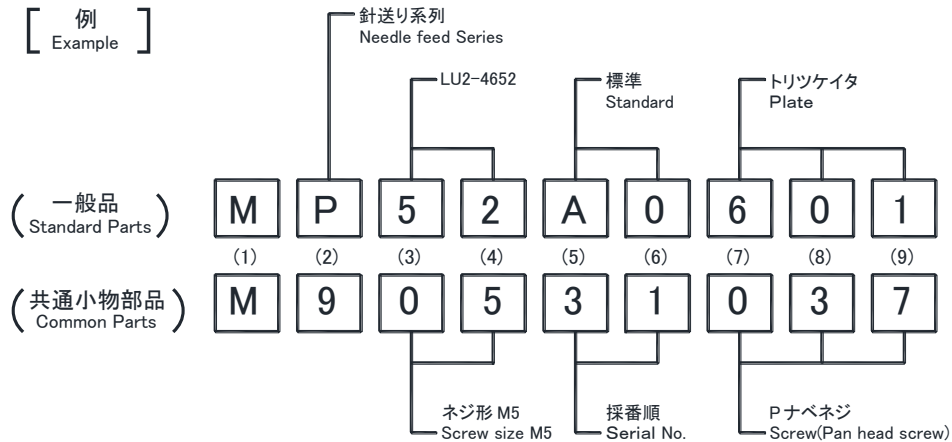

注: 一般品についての機種型名は、その部品が最初に使用された機種型名を示します。従って長期にわたる場合は、機種の変更が行われるため、当初の機種以外の機種で使用されている場合があります。
Sewing machine Models, of Standard Parts are Indicated model of these parts are registered firstly. Parts are used for not only the indicated model, but also another models, in reason of New development, improvement after.

パーツカタログご利用に際して Information on use of the parts catalog

- ・補用品ご注文の際は、部品コードでご注文下さい。また、このパーツブックの管理番号と発行年月(表紙右下,例えば、P-1...202104)モデル機械番号を、合わせてご連絡頂ければ幸いです。
- ・一部の部品について、改良のため予告なしに変更になる場合がありますのでご了承下さい。
- ・このパーツカタログは、2021年4月のデータにもとづいて作成されたものです。
- ・部品コード欄が、 — となっている部品は、補給いたしません。ただし組コードが記載されているものは、組部品として補給いたしますので、組コードでご注文下さい。
- ・使用個数欄の英数字組合せ文字は、このモデル番号のサブ機械番号をしめています。
- ・尚、本パーツブックの記載内容にお気付きの点がありましたら、お知らせ頂ければ幸いです。

- ・When ordering any spare part, please specify its part code. In addition, please specify the management number and issued date of this parts catalog (e.g.P-1 202104 indicated at bottom right of the front cover) and the machine model number.
- ・Some parts are subject to change due to modification without notice.
- ・This parts catalog is based the as of April 2021.
- ・Any part marked-in the part code column will not be supplied. When a part has its assembly code, please specify the assembly code because that part is supplied as an assembly part.
- ・Alphanumerical characters indicated in the required quantity column indicate the sub machine number of this model number.
- ・Please write to us if you have any question on this parts catalog.

A 本体関係
BODY & IT'S ACCESSORIES

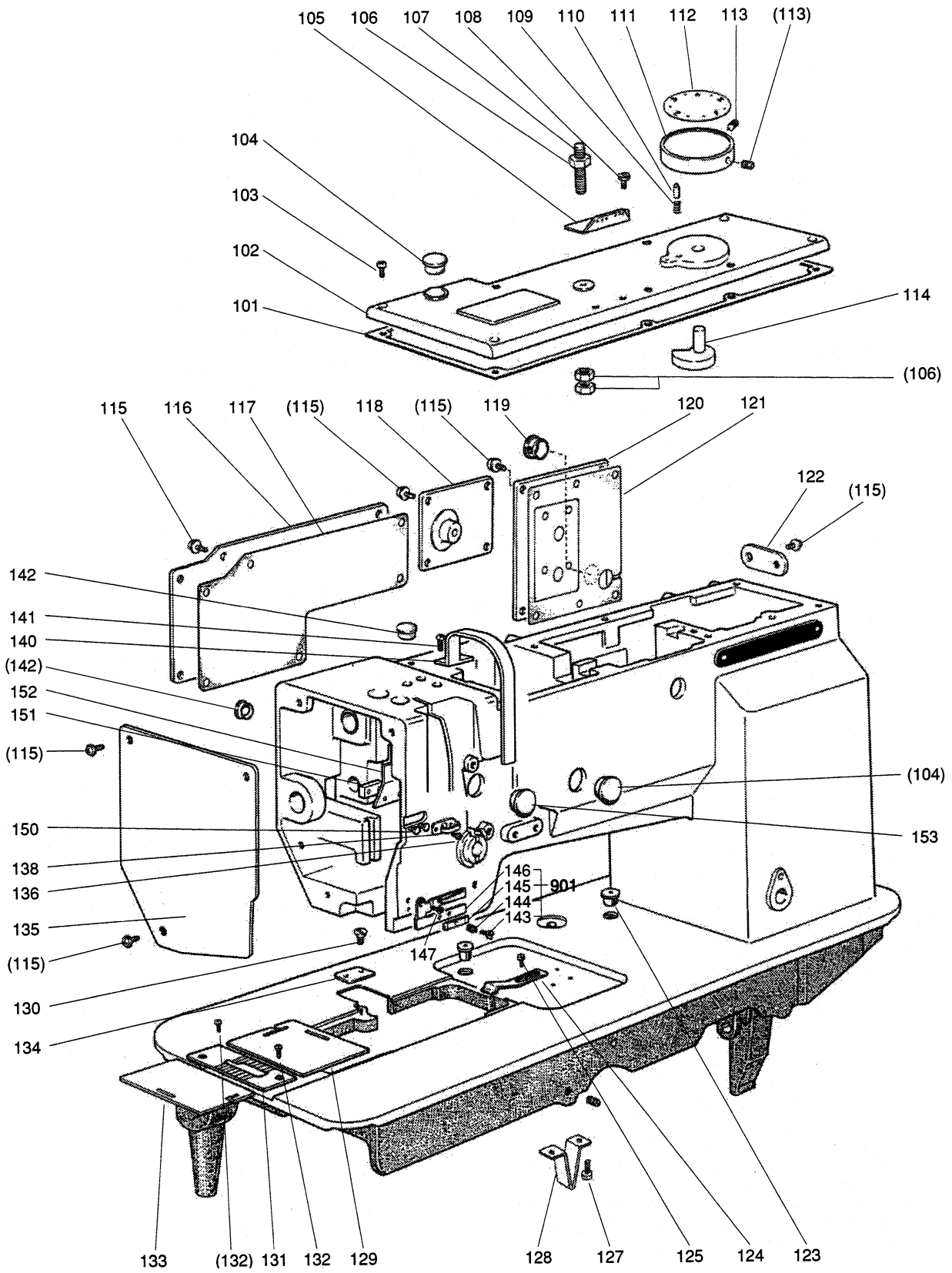

[A] 本体関係
BODY & IT'S ACCESSORIES

Fig. No.	変更 Mod.	部品コード Parts. No.	部品名	Description	使用個数 Amt. Req.
					B1T
A101		MP66A0691	ガasket	Gasket	1
A102	C	MP66A0600	トップカバー	Top cover	1
A103		M91112004	フライネジ	Screw 11/64 (40) × 11	8
A104	C	M91910080	セン	Rubber plug φ19	2
A105		MN40A0180	イトアンナイ	Thread guide	1
A106		M91576045	ロツカクナツト	Nut M6	3
A107		M91652020	トメネジ	Screw M6 × 35	1
A108		M91116002	ヒラネジ	Screw 11/64 (40) × 8	2
A109		MG75A0572	ツルマキハネ	Coil spring	1
A110		M90429060	ピン	Pin	1
A111		MP47A0631	ダイヤル	Dial	1
A112		MP47A0841	メモリタ	Indicating plate	1
A113		M95004020	ロツカクアツキトメネジ	Screw M5 × 8	2
A114		MP47A0152	シヨウケ オクリチヨウセツカム	Upper feed lifting regulator cam	1
A115		M91109004	ザカネツキフライネジ	Screw 11/64 (40) × 9	17
A116		MP67A0880	ヨコフタ2	Arm cover 2	1
A117		MP67A0691	ガasket2	Gasket 2	1
A118		MP66A1880	ヨコフタ1	Arm cover 1	1
A119	C	MP66A0750	ブッシュ	Bushing	1
A120	D	MP52A0237	ウラフタ	Arm cover	1
A121		MP66A2691	ガasket	Gasket	1
A122		MP47A1476	スペーサ	Spacer	1
A123		MN10A4742	フタ	Cap	2
A124		MP61A0192	イタハネ	Spring	1
A125		M91128003	マルヒラネジ	Screw 11/64 (40) × 6	2
A127		M91601003	マルヒラネジ	Screw 1/4 (24) × 9	2
A128		MN50A0426	ササエ	Supporter	1
A129	C	MP67A0473	スペリタ	Slide plate	1
A130	C	M90903010	サラネジ	Screw 9/64 (40) × 6	2
A131		MP69A0101	ハリタ	Needle plate	1
A132		M91104011	マルサラネジ	Screw 11/64 (40) × 8	2
A133		MP66A0470	スペリタ	Slide plate	1
A134		MP61A0742	フタ	Cover	1
A135	C	MP67A0830	メンタ	Face plate	1
A136	C	M90904011	マルサラネジ	Screw 9/64 (40) × 6.5	1
A138	C	MG43A1181	イトアンナイ	Thread guide	1
A140		MP60A0584	テンビンカバー	Thread take-up cover	1
A141		M91110004	フライネジ	Screw 11/64 (40) × 8	1
A142		M91304080	セン	Rubber plug φ13	2
A143		M90804016	マルヒラネジ タンツキ	Screw 1/8 (44) × 3	1
A144		MP60A2572	ツルマキハネ	Spring	1
A145		MP60A0202	イトオサエ	Plate	1
A146		MP60A0180	イトアンナイ	Thread guide	1
A147		M90920002	ヒラネジ	Screw 9/64 (40) × 6.5	1
A150		M91201011	マルサラネジ	Screw 3/16 (28) × 11	2
A151		MN10A0476	スペーサ	Spacer	1
A152		MN10A0131	アブラウケ	Plate	1
A153	C	M91305080	セン	Rubber plug 13	1
A901		MP60E0180	イトアンナイクミタテ	Thread guide assy.	1

B 上糸調節器部分
 THREAD TENSION REGULATOR MECHANISM

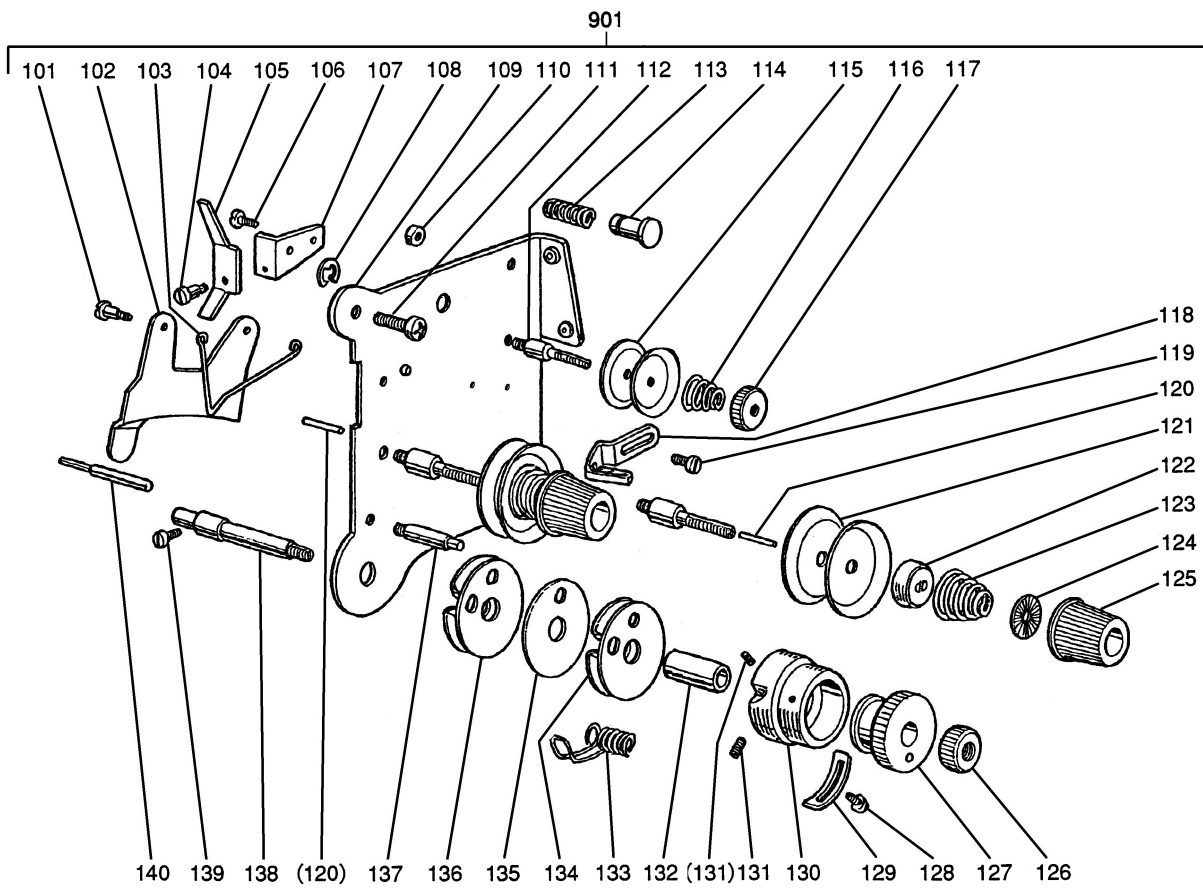

[B] 上糸調節器部分
 THREAD TENSION REGULATOR MECHANISM

Fig. No.	変更 Mod.	部品コード Parts. No.	部品名	Description	使用個数 Amt. Req.
					B1T
B101	C	M90902015	ヒラネジ タンツキ	Screw 9/64(40) × 6	2
B102	C	MN50E0220	イトルメ	Tension releasing plate	1
B103	C	MN10A0851	センサイバネ	Tension releasing spring	1
B104	C	M90927015	ヒラネジ タンツキ	Screw 9/64(40)	1
B105	C	MN72A0950	レバ	Lever	1
B106	C	M90906002	ヒラネジ	Screw 9/64(40) × 4.5	1
B107	C	MN50A6601	トリツケイタ	Mounting plate	1
B108	C	M90505065	Eカ タトメ 5	E-type stop ring 5	1
B109	C	MP61A2601	トリツケイタクミタテ	Mounting plate	1
B110	C	M91101045	ナット	Nut 11/64(40)	1
B111	C	M91106004	フ ラマイネジ	Screw 11/64(40) × 8	2
B112	C	MN70A1553	チョウシボウ	Tension stud	1
B113	C	MN50A4572	ツルマキバネ	Spring	1
B114	C	MP41A1270	オンボタン	Push button	1
B115	C	MF10A1555	チョウシガシラ	Thread regulator disk	2
B116	C	MF36A0245	エンスイバネ	Tension spring	1
B117	C	M91101046	ツマミナット	Thumb nut	1
B118	D	MP47A0180	イトアンナイ	Thread guide	1
B119	C	M90909003	マルヒラネジ	Screw 9/64(40) × 6	1
B120	C	M97008060	ピン	Pin	2
B121	C	MF10A0555	チョウシガシラ	Thread regulator disk	4
B122	C	MH40A0556	チョウシガシラオサエ	Thread tension regulator disc	2
B123	C	MP41A0245	エンスイバネ	Tension spring	2
B124	C	MT60A0802	マワリトメ	Thumb nut revolution stopper	2
B125	C	M91610046	ツマミネジ	Thumb nut 1/4(40)	2
B126	C	M91611046	ツマミナット	Thumb nut 1/4(40)	1
B127	C	MN70A0573	ツマミ	Take-up spring guide	1
B128	C	M90915003	マルヒラネジ	Screw 9/64(40) × 6	1
B129	C	MN70A0477	ストップ	Stopper	1
B130	C	MN70A0154	アンナイガネ	Thread tension post	1
B131	C	M90802001	トメネジ	Screw 1/8(44) × 3.9	2
B132	C	MN70A0750	ブッシュ	Bushing	1
B133	C	MP61A0187	イトトリバネ	Thread take-up spring	1
B134	C	MN70E1175	イタクミタテ	Plate assy.	1
B135	C	MN70A0308	イタ	Plate	1
B136	C	MN70E0175	イタクミタテ	Plate assy.	1
B137	C	M90928015	タンツキネジ	Screw 9/64(40) × 2.9	1
B138	C	MN70A0554	チョウシク	Thread tension stud	1
B139	C	M90910003	マルヒラネジ	Screw 9/64(40) × 7	1
B140	C	M90516060	イトルメピン	Tension releasing pin	1
B901	D	MP47E1210	チョウセツキクミタテ	Thread tension regulator assy.	1

注) Fig. No. 111, 139はFig. No. 901には含まれません。
 Remarks) Fig. No. 111, 139 aren't included in Fig. No. 901.

C 上軸機構
UPPER SHAFT MECHANISM

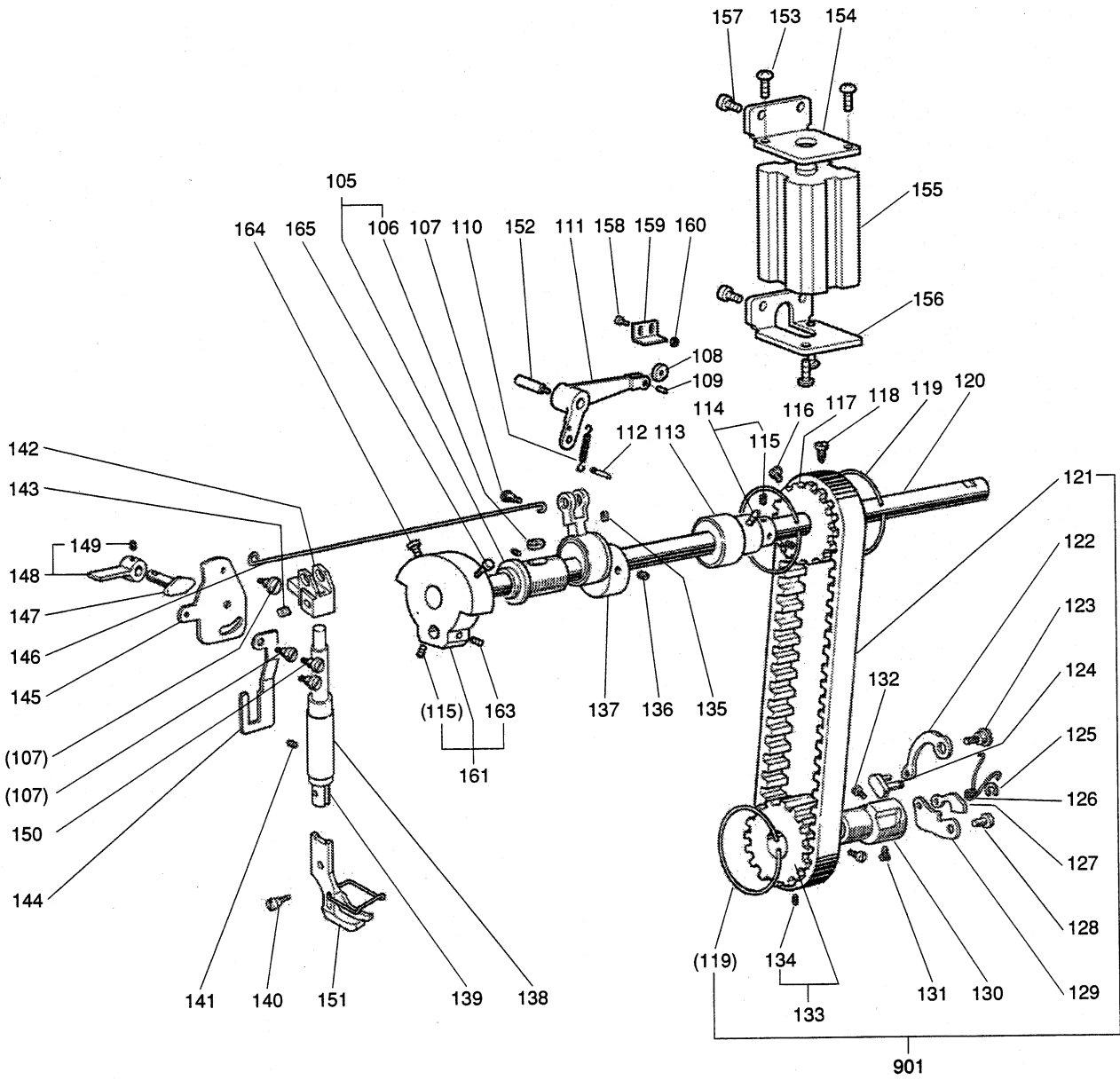

[C] 上軸機構
UPPER SHAFT MECHANISM

Fig. No.	変更 Mod.	部品コード Parts. No.	部品名	Description	使用個数 Amt. Req.	B1T
C105	C	MP67E0232	ウジ ^レ クメタルヒタ ^レ リクミタ ^レ	Arm shaft bushing assy. left	1	
C106		MN10A6740	フェルト	Felt	1	
C107		M91219015	ヒラネジ ^レ ダ ^レ ンツキ	Screw 3/16(28) × 3.5	3	
C108		MP66A0411	コロ	Roller	1	
C109		M90310064	スプリングピン	Spring pin	1	
C110		MP66A0572	ツルマキバネ	Spring	1	
C111		MP66A0228	オサエアゲウテ	Presser bar lifting crank	1	
C112		M95002067	ミノツキピン	Pin φ5×40	1	
C113		MP47A0234	ウジ ^レ クメタルナカクミタ ^レ	Arm shaft bushing assy. middle	1	
C114		MF80A0352	カラクミタ ^レ	Collar	1	
C115	C	M91602001	トメネジ ^レ	Screw 1/4(40) × 4	3	
C116		M91502002	ヒラネジ ^レ	Screw 15/64(28) × 12	1	
C117		MP47A0767	ハカ ^レ タベ ^レ ルトケ ^レ ルマ	Belt pulley	1	
C118		M91501007	マルヒラネジ ^レ ホ ^レ ウサキ	Screw 15/64(28) × 14.5	1	
C119		MN10A1851	センサイクハネ	Spring flange	3	
C120		MP67A0230	ウジ ^レ ク	Arm shaft	1	
C121		MP47A0523	ハカ ^レ タベ ^レ ルト	Cog belt	1	
C122	C	MP00B0871	イタバネ	Spring plate	1	
C123		M90605063	ハンシンジク	Pin φ6×14.5	1	
C124	C	MP00B1910	リンク	Link	1	
C125		M90513065	E ^レ タ ^レ トマ ^レ 2.5	E-type stop ring 2.5	1	
C126		MP00B0729	ヒネリハネ	Twist spring	1	
C127		MP00B0346	ツメ	Plate	1	
C128		M90617063	ダ ^レ ンツキジク	Pin φ6.35×20	1	
C129		MP00B0952	ツメ	Plate	1	
C130		MP00B1750	ブツシユ	Bushing	1	
C131		M91503007	マルヒラネジ ^レ ホ ^レ ウサキ	Screw 15/64(28) × 10.5	1	
C132		M91515002	ヒラネジ ^レ	Screw 15/64(28) × 10	1	
C133		MP66E0768	ハカ ^レ タベ ^レ ルトケ ^レ ルマ	Belt pulley lower	1	
C134		M91503001	トメネジ ^レ	Screw 15/64(28) × 4	2	
C135		M91506001	トメネジ ^レ	Screw 15/64(28) × 6.5	1	
C136		M91513001	トメネジ ^レ	Screw 15/64(28) × 9.5	1	
C137		MP47A0305	オカリロツクミタ ^レ	Upper feed lifting rock crank	1	
C138		MP66A0267	オサエホ ^レ ウメタル	Presser bar bushing	1	
C139		MP67A0262	オサエホ ^レ ウ	Presser bar	1	
C140		M90851015	ヒラネジ ^レ ダ ^レ ンツキ	Screw 1/8(44) X4	1	
C141		M91516001	トメネジ ^レ	Screw 15/64(28) × 13.5	1	
C142		MP67A0265	オサエホ ^レ ウタ ^レ キ	Bracket	1	
C143		M94001001	トメネジ ^レ	Screw M5X6	1	
C144		MP47A0510	ソウサイタ	Operation plate	1	
C145		MP47A1252	オサエアゲレハ ^レ ヒタ ^レ リ	Knee lifter lever left	1	
C146		MP66A0738	ヒキホ ^レ ウ	Knee lifter rod	1	
C147	C	MP67A0253	オサエアゲカム	Presser bar lifting cam	1	
C148		MN70A2252	オサエアゲクミタ ^レ	Presser bar lifter assy.	1	
C149		M91108001	トメネジ ^レ	Screw 11/64(40) × 5.5	2	
C150		M91503031	ボルト	Bolt 15/64(28) × 6.7	2	
C151	C	MP60E0106	オサエクミタ ^レ	Presser foot	1	
C152		MP66A0454	ジク	Pin	1	
C153		M91505004	Pナ ^レ ネジ ^レ M6X20	P-NA M6X20	4	
C154		MP66A1601	トリツケイタ	Adapter	1	
C155		MP66A0434	ウスカ ^レ タンリンダ ^レ	Cylinder	1	
C156		MP66A0601	トリツケイタ	Adapter	1	
C157		M90511056	セフテイソケット	Screw M5X8	4	
C158		M95045021	セフテイソケット	Bolt M5X14	2	
C159		MP66A0477	ストップ	Stopper	1	
C160		M91382045	ロツカクナツト	Nut M5	2	
C161		MN42A0383	クランククミタ ^レ	Crank	1	
C163		M91606001	トメネジ ^レ	Set screw 1/4(40) × 7	1	
C164		M91801002	ヒラネジ ^レ	Screw 9/32(28) × 13	1	
C165		M91802006	ヒラネジ ^レ ホ ^レ ウサキ	Screw 9/32(28) × 14	1	
C901		MP47E0768	ハカ ^レ タベ ^レ ルトケ ^レ ルマクミタ ^レ	Belt pulley lower assy.	1	

D 針棒・天秤機構
NEEDLE BAR & THREAD TAKE-UP LEVER MECHANISM

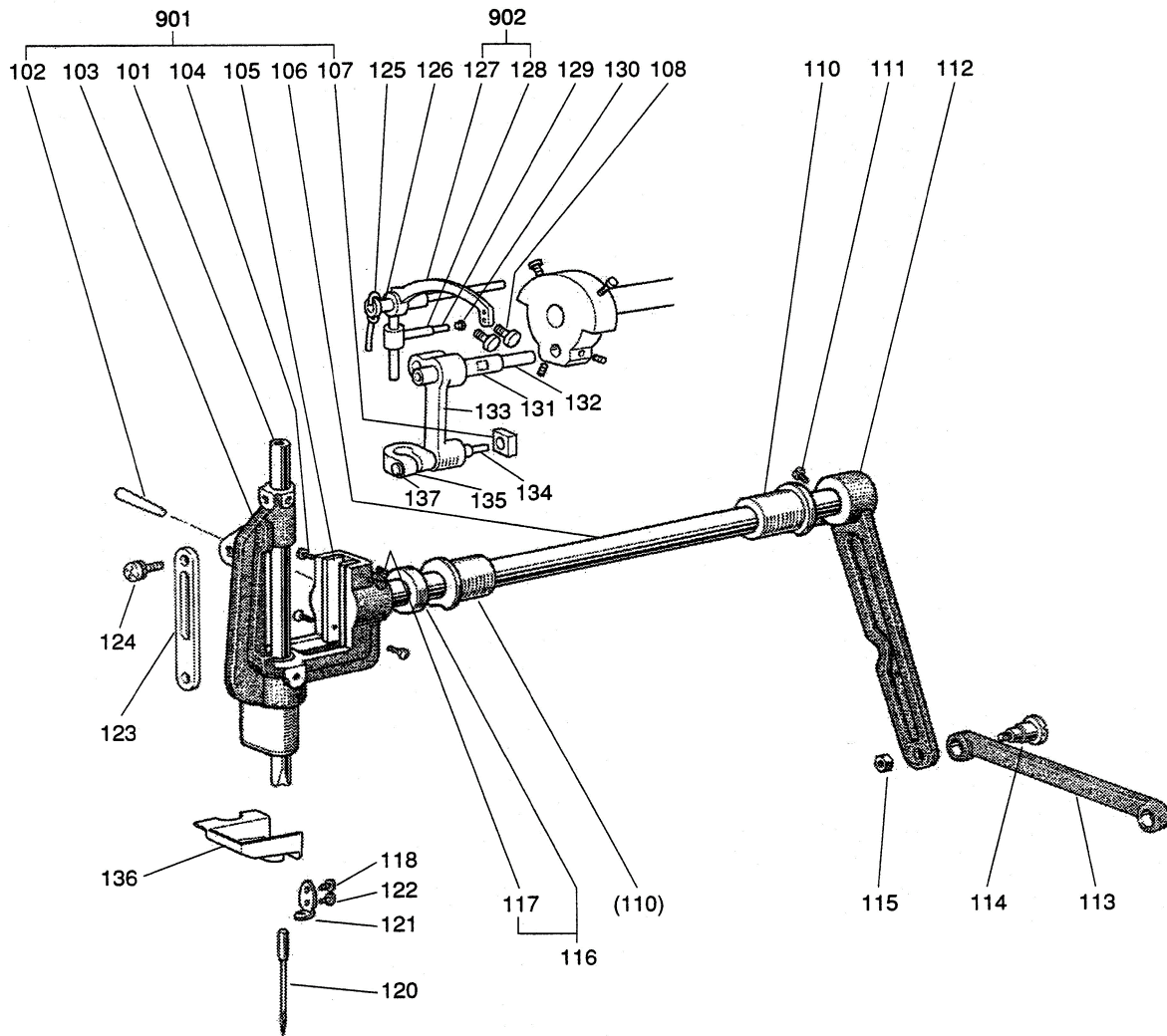

[D] 針棒・天秤機構
NEEDLE BAR & THREAD TAKE-UP LEVER MECHANISM

Fig. No.	変更 Mod.	部品コード Parts. No.	部品名	Description	使用個数 Amt. Req.
					B1T
D101		MP66A0660	ハリ棒	Needle bar	1
D102		M90401061	テーパピン	Taper $\phi 4 \times 23$	1
D103		—	ササエ	Needle bar rock frame	1
D104		M90604011	マルサラネジ	Screw 3/32(56) $\times 4$	4
D105	C	MN10A1476	スペーサ	Spacer	2
D106		—	ハリ棒ウヨウトウシク	Needle bar rock shaft	1
D107	C	MN40A1325	カクコマ	Square block	1
D108		M91502002	ヒラネジ	Screw 15/64(28) $\times 12$	2
D110		MN40A0669	ハリ棒ウヨウトウシクメタル	Needle bar vibrating shaft bushing	2
D111		M91603003	マルヒラネジ	Screw 1/4(24) $\times 16$	1
D112		MP47A0886	ハリ棒ウヨウトウウテ	Needle bar rock crank	1
D113		MP67A1956	レンセツカン	Needle bar rock link	1
D114		M91507015	ヒラネジ タンツキ	Screw 15/64(28)	1
D115		M91502045	ナット	Nut 15/64(28)	1
D116		MN70A0352	カラークミタテ	Collar assy.	1
D117		M91606001	トメネジ	Screw 1/4(40) $\times 5$	1
D118		M90602002	ヒラネジ	Screw 3/32(56) $\times 3$	1
D120		ML75A0128	ミシンハリ DP $\times 17-21$	Needle DP $\times 17-21$	1
D121		MP46A0181	イトアンナイ	Thread guide	1
D122		M90823002	ヒラネジ	Screw 1/8(44) $\times 3.7$	1
D123		MP47A0359	ガイド	Guide plate	1
D124		M91109004	サカネツキフ ラマイネジ	Screw 11/64(40) $\times 9$	2
D125		MF10E2148	ヒモ	Oil wick 2.5 $\times 240$	1
D126		MP67A0587	テンピンササエシク	Pin for thread take-up lever	1
D127	D	—	テンピン	Thread take-up lever	1
D128	D	—	スペリガネ	Slide block	1
D129		MF10E3148	ヒモ	Oil wick 3 $\times 25$	1
D130		MN10A0500	セン	Plug	1
D131		MN70A0387	ハリ棒ウクラシク	Needle bar crank pin	1
D132		MP60A0148	ヒモ	Oil wick 3 $\times 80$	1
D133	D	MP52A0956	レンセツカン	Needle bar connecting link	1
D134		MP67A0740	フェルト	Felt	1
D135	D	MP52A0665	ハリ棒ウタキ	Needle bar holder	1
D136		MP67A0417	アブラウケゴム	Oil shield rubber	1
D137	C	M90949003	マルヒラネジ	Screw 9/64(40) $\times 8.5$	1
D901	C	MP67E0666	ハリ棒ウササエヨウトウシククミタテ	Needle bar rock frame shaft assy.	1
D902	D	MP60E1582	テンピンスペリガネクミタテ	Thread take-up lever assy.	1

□ E 上部上下送り機構
UPPER FEED LIFTING ROCK SHAFT MECHANISM

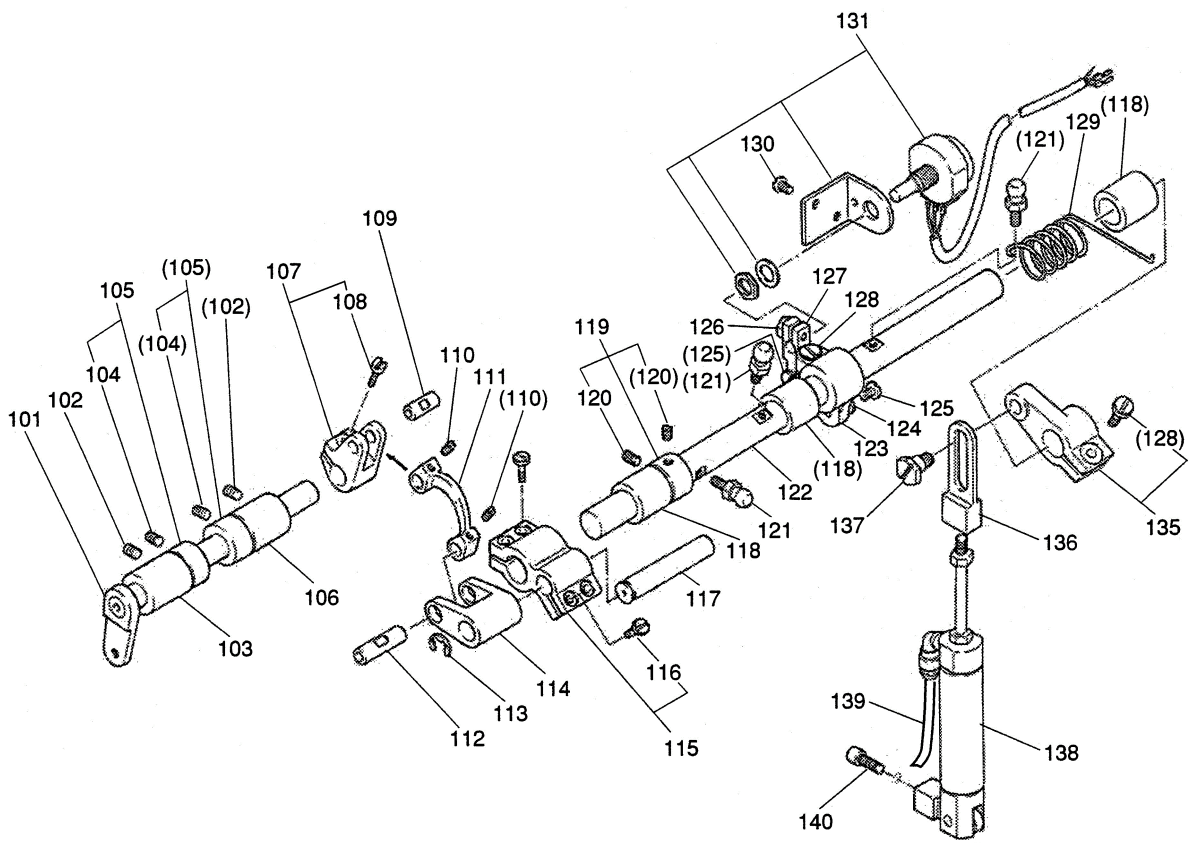

[E] 上部上下送り機構
UPPER FEED LIFTING ROCK SHAFT MECHANISM

Fig. No.	変更 Mod.	部品コード Parts. No.	部品名	Description	使用個数 Amt. Req.
					B1T
E101		MG75A0460	ジヨウブジヨウゲジク	Upper feed lifting rock shaft	1
E102		M91108001	トメネジ	Screw 11/64(40) × 5.5	2
E103		MP47A0286	ジヨウブジヨウゲメタル	Upper feed lifting rock shaft bushing	1
E104		M91503001	トメネジ	Screw 15/64(28) × 4	2
E105		MP47E0352	カラークミタテ	Collar assy.	2
E106		MP66A0833	ジヨウブジヨウゲメタル	Upper feed lifting rock shaft bushing	1
E107	C	MG75E0463	ジヨウブジヨウゲウテミギクミ	Upper feed lifting rock shaft crank right assy.	1
E108		M91505002	ヒラネジ	Screw 15/64(28) × 13.5	1
E109		MG75A4454	ジク	Pin	1
E110		M91106001	トメネジ	Screw 11/64(40) × 3.75	2
E111		MG75A6956	レンセツカン	Link	1
E112		MG75A6454	ジク	Pin	1
E113		M90516065	Cカゝトメワジクヨウ10	Retaining ring C-type 10	1
E114		MG75A2910	リンク	Link	1
E115		MP47E0228	ウテクミタテ	Crank	1
E116		M91112002	ヒラネジ	Screw 11/64(40) × 12	4
E117		MP47A3454	ジク	Pin	1
E118		MG75A0285	オクリシクメタル	Feed rock shaft bushing	3
E119		MF80A0352	カラークミタテ	Collar	1
E120		M91602001	トメネジ	Screw 1/4(40) × 4	2
E121		M91508030	トクシユネジ	Screw 15/64(28) × 10	3
E122		MP66A0559	オクリチヨウセツジク	Upper feed regulator shaft	1
E123		MP47A1228	ウテ	Crank	1
E124		MP47A0910	リンク	Link	1
E125		M91102015	ヒラネジ タンツキ	Screw 11/64(40) × 4	2
E126		M90107024	ミゾツキホルト	Screw 11/64(40) × 12	1
E127		MP66A1228	ウテ	Crank	1
E128		M91506002	ヒラネジ	Screw 15/64(28) × 14	2
E129		MP47A0729	ヒネリハネ	Spring	1
E130		M91111004	プーラマイネジ	Screw 11/64(40) × 10	2
E131	C	MP47E1787	ポテンシヨメータクミタテ	Potentiometer assy.	1
E135		MP47E1228	コウコハンカンウテクミタテ	Alternating crank	1
E136		MP47A0621	ナツクル	Knuckle	1
E137		M91503031	ホルト	Bolt 15/64(28) × 6.7	1
E138		MP47A0434	エアシリンダクミタテ	Air cylinder assy.	1
E139		MP47A0567	エアチューブ	Air tube	1
E140		M95001021	ロツカクアナツキホルト	Screw M5 × 16	1

F 押え機構
PRESSER FOOT MECHANISM

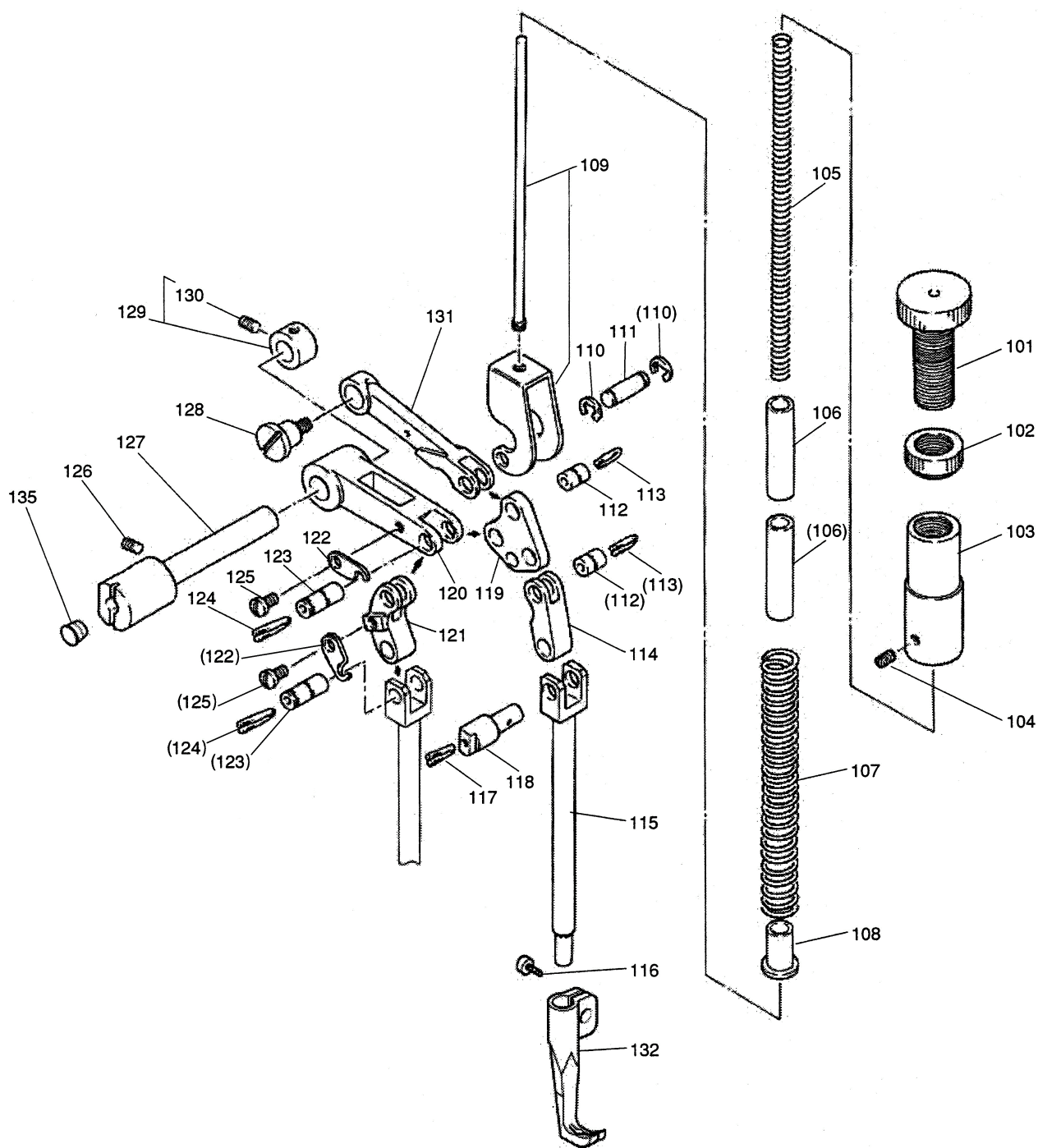

[F] 押え機構
PRESSER FOOT MECHANISM

Fig. No.	変更 Mod.	部品コード Parts. No.	部品名	Description	使用個数 Amt. Req.
					B1T
F101		M93222035	ツマミネジ	Thumb nut 1/2 (28) × 35.5	1
F102		M93202047	トクシユナツト	Special nut 1/2 (28)	1
F103		MP47A0267	オサエホウメタル	Presser bar bushing	1
F104		M91506001	トメネジ	Screw 15/64 (28) × 6.5	1
F105		MP47A0572	ツルマキハネ	Spring	1
F106		MP47A0476	スペーサ	Spacer	2
F107		MP47A1572	ツルマキハネ	Spring	1
F108		MP47A0750	ブッシュ	Bushing	1
F109		MP47E0704	オサエハネアンナイクミタテ	Presser spring guide	1
F110		M90504065	Eガタトメワ 4	E-type stop ring 4	2
F111		M90533060	ピン	Pin	1
F112		MP47A4454	ジク	Triangle lever shaft	2
F113		MP47A1148	ヒモ	Oil wick φ2×15	2
F114		MP47A2910	リンク	Link	1
F115		MP66A0881	ヨウトウオサエホウ	Vibrating prevention bar	1
F116		M91108002	ヒラネジ	Screw 11/64 (40) X7	1
F117	C	MP47A3148	ヒモ	Oil wick φ2×40	1
F118	C	MP47A1359	ガイドピン	Guide pin	1
F119		MP47A0590	サンカクテコ	Triangle lever	1
F120		MP47A0252	オサエアゲレバー	Presser bar lifter crank	1
F121		MP47A3910	リンク	Link	1
F122	C	MP47A0456	サンカクテコシフトメ	Triangle lever shaft stopper	2
F123	C	MP47A5454	ジク	Triangle lever shaft	2
F124	C	MP47A2148	ヒモ	Oil wick φ2×30	2
F125	C	M90944003	マルヒラネジ	Screw 9/64 (40) × 5	2
F126	C	M91111001	トメネジ	Screw 11/64 (40) × 10	1
F127		MP67A0454	ジク	Shaft	1
F128		M91681015	ヒラネジ タンツキ	Screw 1/4 (40) × 5	1
F129		MP47E1352	カラークミタテ	Collar	1
F130		M91103001	トメネジ	Screw 11/64 (40) × 3	1
F131		MP47A1910	リンク	Link	1
F132	A	MP66A0107	ウチオサエ	Presser foot	1
F135		M90573080	ゴムセシ	Rubber plug 5.7	1

G
 縫目加減機構
 STITCH REGULATOR MECHANISM

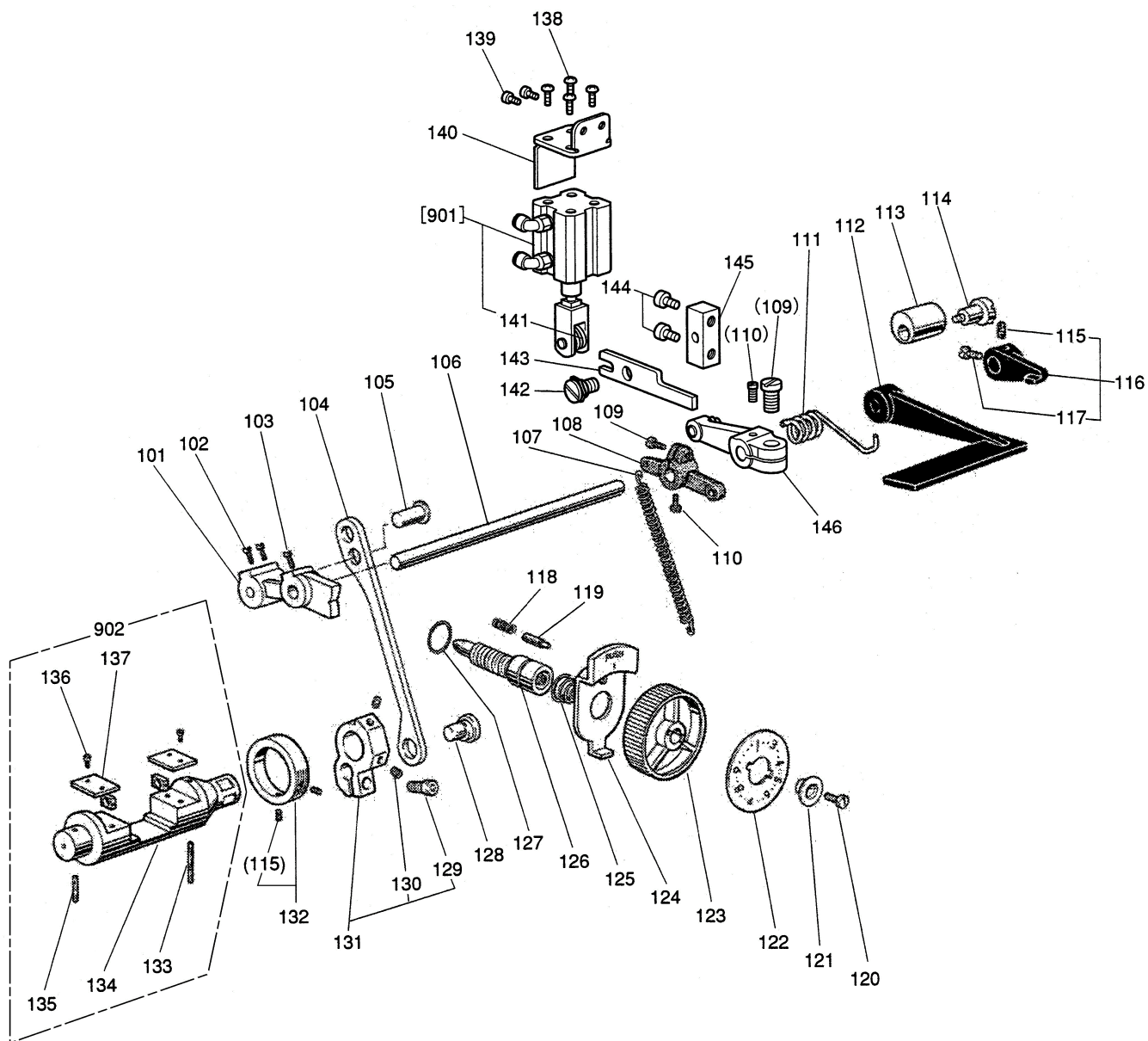

[G] 縫目加減機構
STITCH REGULATOR MECHANISM

Fig. No.	変更 Mod.	部品コード Parts. No.	部品名	Description	使用個数 Amt. Req.
					B1T
G101		MP47A0291	オクリチヨウセツカム	Feed regulator cam	1
G102		M91516002	ヒラネジ	Screw 15/64 (28) × 8.5	2
G103		M91505007	ヒラネジ ボウサキ	Screw 15/64 (28) × 12	1
G104		MP60A0956	レンセツカン	Link	1
G105		M90904060	ピン	Pin	1
G106		MP52A0320	カエシツイクウエ	Reverse Stitch Shaft Upper	1
G107		MN60A2572	ツルマキバネ	Spring	1
G108		MN50A6228	ウテ	Crank	1
G109		M91505002	ヒラネジ	Screw 15/64 (28) × 13.5	2
G110		M91102002	ヒラネジ	Screw 11/64 (40) × 8.5	2
G111		MP61A0729	ヒネリバネ	Spring	1
G112		MN72A0632	ヌイメカゲンレバ	Reverse sewing lever	1
G113		MN50A0417	ゴムワ	Rubber ring φ16	1
G114		M91516015	ヒラネジ ダンツキ	Screw 15/64 (28) × 6	1
G115		M91506001	トメネジ	Screw 15/64 (28) × 6.5	3
G116		MN72A1950	レバークミタテ	Lever assy.	1
G117		M91519002	ヒラネジ	Screw 15/64 (28) × 7.5	1
G118		MF10A2572	ツルマキバネ	Spring	1
G119		MF00A0852	ピン	Pin	1
G120		M91215002	ヒラネジ	Screw (28) × 12	1
G121		MF00A0257	オサエカネ	Bushing	1
G122		MP69A0841	メモリイタ	Stitch Length Indicating Plate	1
G123		MF01A0631	ダイヤル	Dial	1
G124		MF00A0950	レバ	Stopper pin releasing lever	1
G125		MF02A0245	エンスイバネ	Coil spring	1
G126	C	MF90A0640	オクリチヨウセツネジ	Screw bar	1
G127		M91000085	Oリング	O-ring φ10	1
G128		MP60A0761	ヘンシンジク	Eccentric shaft	1
G129		M95014021	ロツカクアナツキホルト	Screw M5 × 14	1
G130		M95008020	ロツカクアナツキトメネジ	Screw M5 × 6	2
G131		MP60E1635	ヌイメカゲンウテシタクミタテ	Reverse sewing crank lower	1
G132	C	MN45A0352	カラークミタテ	Collar assy.	1
G133		MP40A1740	フェルト	Felt	1
G134	C	—	カエシタテ	Reverse block	1
G135		MP40A0740	フェルト	Felt	1
G136		M91106004	フ ラマイネジ	Screw 11/64 (40) × 8	4
G137		MN45A0154	アンナイイタ	Guide plate	2
G138		M96062021	ボタンホルト	Screw	4
G139	C	M95002017	セフテイソケツト	Bolt	2
G140		MP52A0601	トリツケイタ	Mounting plate	1
G141		M90519050	ナイロンワッシャ	Nylon washer	2
G142	C	M91503031	ホルト	Bolt	1
G143		MP52A0910	クトウリンク	Rink	1
G144		M95004017	セフテイソケツト	Bolt M5X16	2
G145		MP52A0603	トリツケダイ	Bracket	1
G146		MP52A0228	ウテクミタテ	Crank assy.	1
G901		MP69A0434	エアシリンダークミタテ	Air cylinder assembly	1
G902	C	MP60A0321	カエシタテフェルトクミタテ	Reverse block assy.	1

H 下軸・送り機構
 LOWER SHAFT & FEED ROCKING MOTION MECHANISM

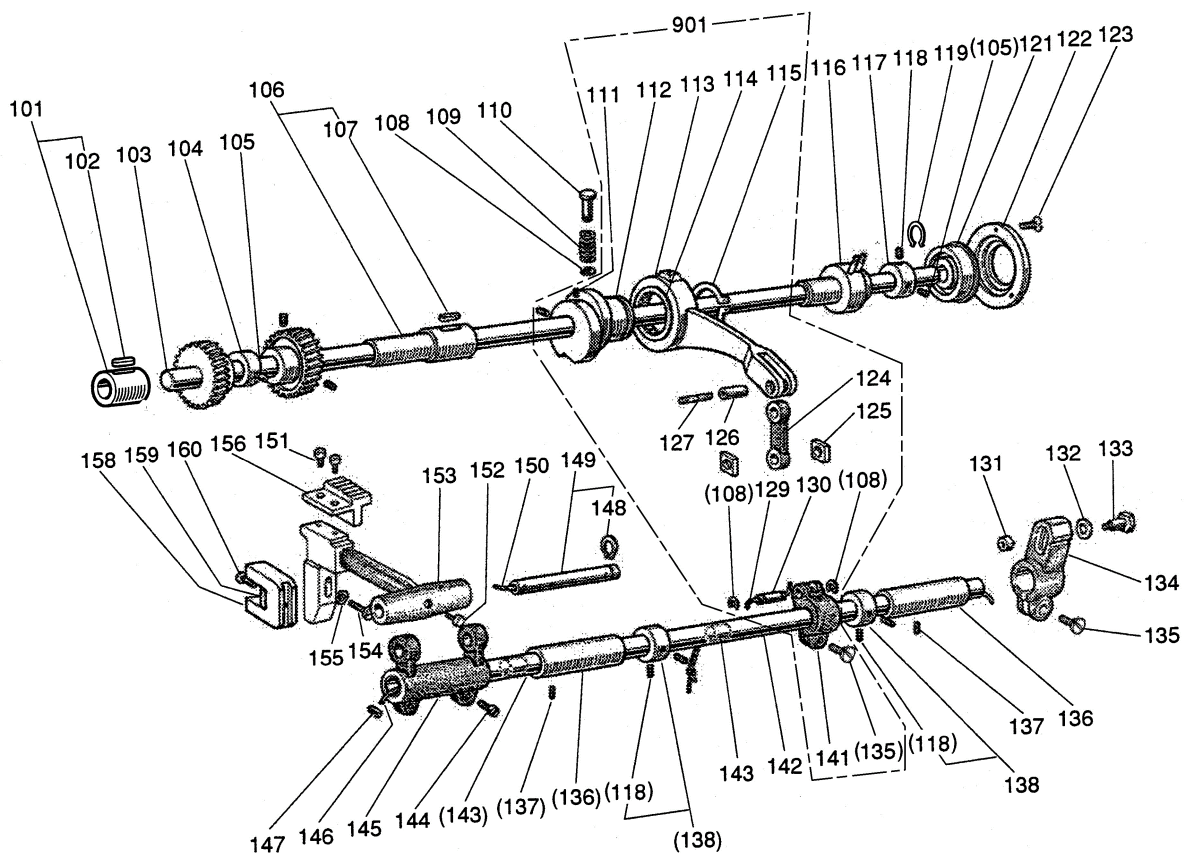

[H] 下軸・送り機構 LOWER SHAFT & FEED ROCKING MOTION MECHANISM

Fig. No.	変更 Mod.	部品コード Parts. No.	部品名	Description	使用個数 Amt. Req.
					B1T
H101		MP66E0451	シタジクメタルヒタリクミタテ	Lower shaft busing left	1
H102		MG23C6740	フェルト	Felt	2
H103		MP66A0450	シタジク	Lower shaft	1
H104		MN10A0292	ヘンジンリン	Feed eccentric cam	1
H105	C	M91603001	トメネジ ホウサキ	Screw 1/4 (40) × 5	2
H106		MP40A0452	シタジクメタルミキクミタテ	Lower shaft bushing right	1
H107		MN70E1148	ヒモ	Oil wick φ2×85	1
H108	C	M90505065	Eカクタメワジクヨウ 5	E-type stop ring 5	3
H109		MP41A0572	ツルマキバネ	Spring	1
H110		MP41A0270	オンボタン	Push buttons	1
H111		M91516001	トメネジ	Screw 15/64 (28) × 13.5	2
H112	C	—	スイヘイオクリカム	Feed eccentric	1
H113	C	—	オカリロッド	Feed connecting rod	1
H114		MN40A0456	ジクウケ	Needle bearing	1
H115		M90526065	Cカクタメワジクヨウ 26	Retaining ring C-type 26	1
H116		MP40E0453	シタジクメタルナカクミタテ	Lower shaft busing assy. middle	1
H117		MP47A2750	ブツシュ	Bush	1
H118	C	M91602001	トメネジ	Screw 1/4 (40) × 4	5
H119		M90317065	Cカクタメワジクヨウ 17	Retaining ring C-type 17	1
H121		MN10A2456	ジクウケ	Ball bearing	1
H122		MN10A0771	オサエイタ	Bearing holder	1
H123		M90902011	マルサラネジ	Screw 9/64 (40) × 7	3
H124		MN40A1956	レンゼツカン	Link	1
H125		MN40A0325	カクコマ	Square block	2
H126		MN40A0454	ジク	Shaft	1
H127		MP40A0148	ヒモ	Oil wick φ3×26	1
H129		MP40A0148	ヒモ	Oil wick φ3×55	1
H130		MN40A1454	ジク	Pin	1
H131		M91572045	U ナット	U nut M6 × (0.75)	1
H132		M90602050	ザガネ	Washer	1
H133		M91552015	トクシユホルト	Bolt M6	1
H134		MP67A0279	スイヘイオクリウテミキ	Feed rock shaft crank right	1
H135	C	M91603006	マルヒラネジ	Screw 1/4 (24) × 16	2
H136		MF70A0286	オカリシクメタル	Feed rock shaft bushing	2
H137		M91654001	トメネジ	Screw 1/4 (24) × 13	2
H138		MF80A0352	カラークミタテ	Collar	2
H141		MN40A0273	オカリウテナカ	Feed connection crank middle	1
H142		MP66A0491	スイヘイオクリジク	Feed rock shaft	1
H143	D	MP47A1740	フェルト	Felt	2
H144		M91204003	マルヒラネジ	Screw 3/16 (28) × 12	2
H145		MN50A0278	スイヘイオクリウテヒタリ	Feed connection crank left	1
H146		MP66A0148	ヒモ	Oil wick φ2.5×500	1
H147		MF80A0780	ホルタ	Clip	1
H148		M90335065	Cカクタメワジクヨウ 7	Retaining ring C-type 7	1
H149	C	MP47A1454	ジククミタテ	Shaft assy.	1
H150		MF10E2148	ヒモ	Oil wick φ2.5×150	1
H151		M90803020	ロツカクアナツキホルト	Bolt 1/8 (40) × 7	2
H152		M95004021	ロツカクアナツキトメネジ	Screw M5 × 5	1
H153		MP47A0281	オカリタイ	Feed bar	1
H154	C	M91513022	ホルト	Bolt 15/64 (28) × 16	1
H155		M90631050	ミガキザガネ	Washer 6	1
H156		MP69A0104	オクリ	Feed dog	1
H158	C	MP60A0744	フタマタ	Feed bar forked connection	1
H159		MP42A0740	フェルト	Felt	1
H160	C	M90810002	ヒラネジ	Screw 1/8 (44) × 6.5	1
H901	C	MP60E0305	オカリロッドクミタテ	Feed connecting rod assy.	1

J カマ台機構
HOOK SADDLE MECHANISM

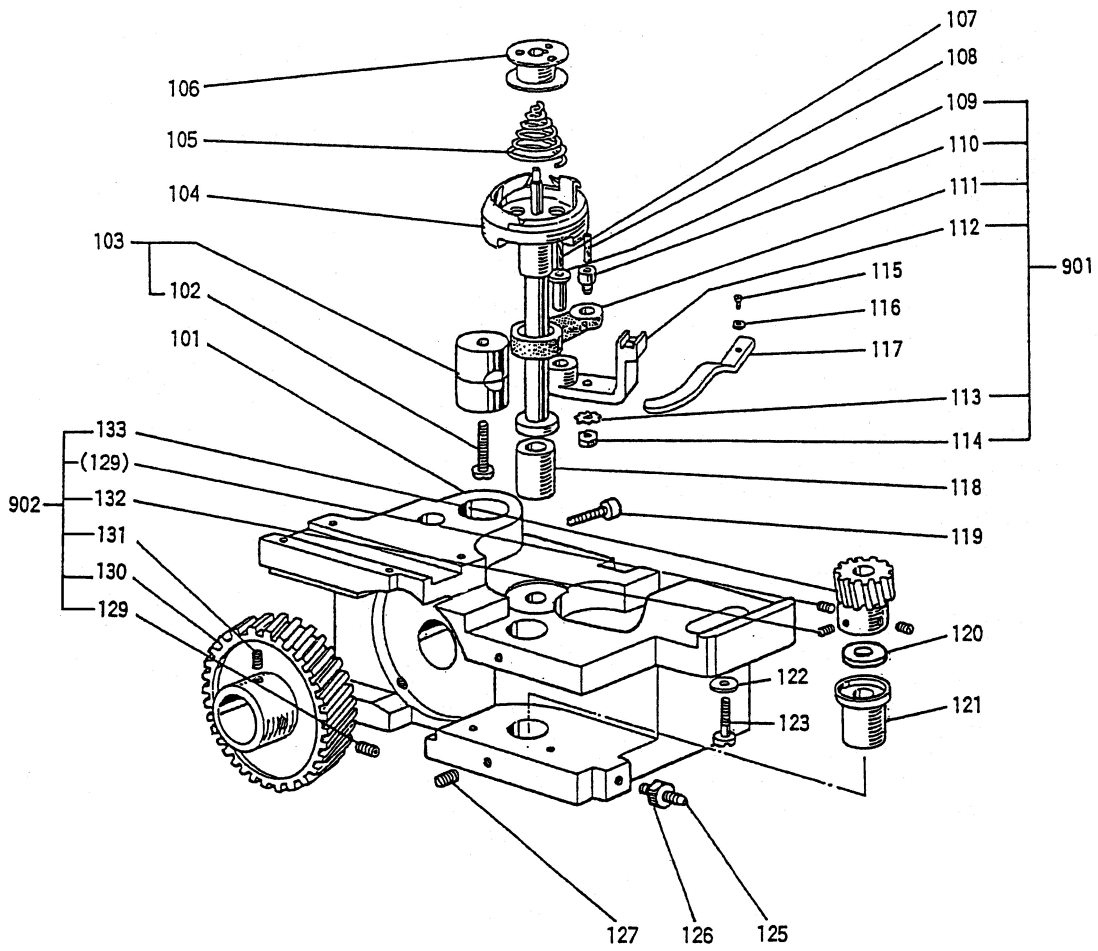

[J] カマ台機構
HOOK SADDLE MECHANISM

Fig. No.	変更 Mod.	部品コード Parts. No.	部品名	Description	使用個数 Amt. Req. B1T
J101		MP66A0345	カマダ イミキ	Hook saddle right	1
J102		M91509002	ヒラネジ	Screw 15/64 (28) × 22	1
J103		MN70A2750	ブッシュクミタテ	Bushing assy.	1
J104	C	MP67A2120	カマクミタテ	Hook assy.	1
J105		MN52A2245	エンスイバネ	Spring	1
J106		MP60A0123	ボビン	Bobbin	1
J107		MF10E2148	ヒモ	Oil wick φ2.5 × 24	1
J108		MF10E2148	ヒモ	Oil wick φ2.5 × 15	1
J109		MN10A0302	オーフナーサエシク	Opener bracket shaft	1
J110		M91260030	トクシユネジ	Screw 3/16 (32) × 3.8	1
J111		MP40A0340	レンセツカン	Link	1
J112		MN52A0301	オーフナーサエ	Opener bracket	1
J113		M90501053	バネサガネ 5	Spring washer 5	1
J114		M91252045	ナット	Nut	1
J115		M90910003	マルヒラネジ	Screw 9/64 (40) × 7	1
J116		M90401050	サガネ	Washer	1
J117		MN52A0300	オーフナー	Opener	1
J118		MN12B0342	カマシクメタルウエ	Hook shaft bushing upper	1
J119		M91201020	ロツカクアナツキトメネジ	Screw 3/16 (28) × 14.5	1
J120		M91001050	サガネ	Washer	1
J121		MN10A0343	カマシクメタルシタ	Hook shaft bushing lower	1
J122		M90607050	ミガキサガネ 6	Washer 6	1
J123		M91652002	ヒラネジ	Screw 1/4 (24) × 23	1
J125		M91205030	トクシユネジ	Screw 3/16 (28) × 11.5	1
J126		M91201045	ナット	Nut 3/16 (28) × 3	1
J127		M91503001	トメネジ	Screw 15/64 (28) × 4	2
J129		M91602001	トメネジ	Screw 1/4 (40) × 4	3
J130		MP41E0642	ネジハグルマ	Hook driving gear large	1
J131		M91655001	トメネジ	Screw 1/4 (40) × 6.5	1
J132		M91603001	トメネジ ホウサキ	Screw 1/4 (40) × 5	1
J133		MP00B0643	ネジハグルマ	Hook driving gear small	1
J901		MN10E0301	オーフナーサエクミ	Opener bracket assy.	1
J902	C	MP41E0644	ネジハグルマクミタテ	Gear assy.	1

K 糸切り機構 (I)
 THREAD TRIMMING MECHANISM (I)

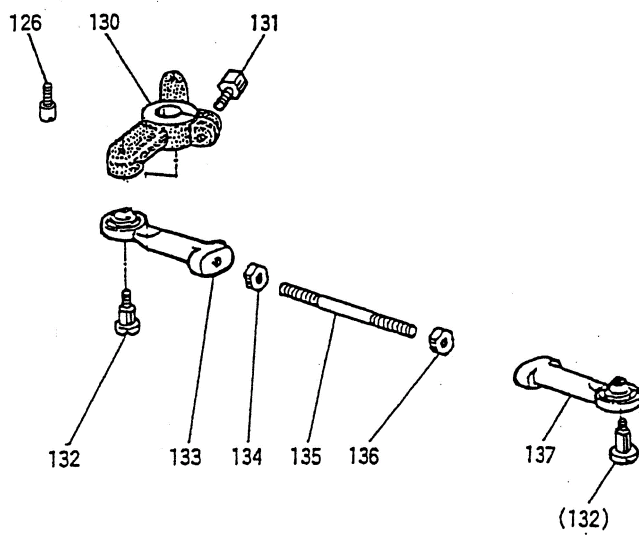
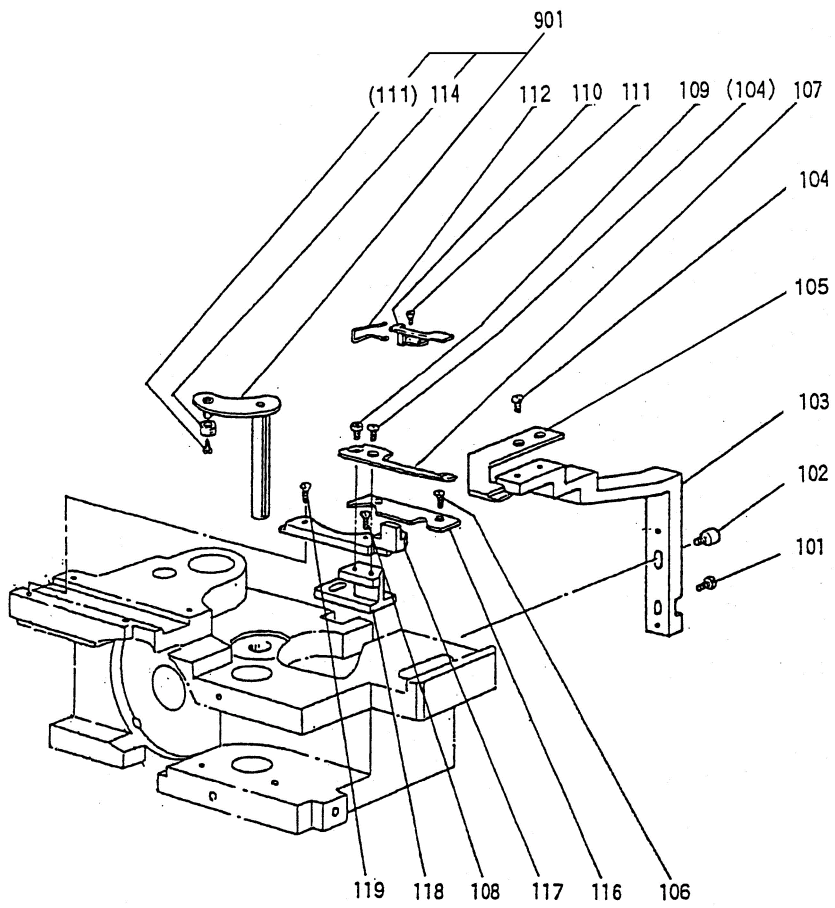

[K] 糸切り機構 (I)
 THREAD TRIMMING MECHANISM (I)

Fig. No.	変更 Mod.	部品コード Parts. No.	部品名	Description	使用個数 Amt. Req.
					B1T
K101		M90911030	トクシユネジ	Screw	1
K102		M91106022	ロツカクアナツキホルト	Bolt 11/64(40) × 12	1
K103		MN50A0839	メストリツケダイ	Trimming knife holder	1
K104	C	M90907010	サラネジ	Screw 9/64(40) × 5	3
K105		MP69A0838	コテイメス	Fixed Knife	1
K106	C	M90903010	サラネジ	Screw 9/64(40) × 6	2
K107		MP41B0838	イドウメス	Moved knife	1
K108		M90801010	サラネジ	Screw 1/8(44) × 10	1
K109		M90944002	ヒラネジ	Screw 9/64(40) × 4.5	1
K110		MN50A0192	イタハネ	Spring plate	1
K111		M90605002	ヒラネジ	Screw 3/32(56) × 3.8	3
K112		MN50A0507	センザイクハネ	Reversing spring	1
K114		MN60A0411	コロ	Roller	1
K116		MN60A2742	フタ	Cover	1
K117		MN60E0154	アンナイガイネ	Guide	1
K118		MN60A0837	メスタイ	Knife pad (right)	1
K119		M90906010	サラネジ	Screw 9/64(40) × 9.5	1
K126		M91111033	ピンネジ	Screw 11/64(40) × 6	1
K130		MN60A2228	ウテ	Arm	1
K131		M91509022	ホルト	Bolt 15/64(28) × 12.5	1
K132	C	M91271015	ヒラネジ タンツキ	Screw M5(0.5) × 8.5	2
K133		MN72A0975	ロツトエンド	Ball joint	1
K134		M91374045	ナツト ヒタリ M5	Nut M5 left	1
K135		M95010023	ウエコミホルト	Bolt	1
K136		M91377045	ナツトM5	Nut M5 right	1
K137	C	MB62A0975	ロツトエンド	Ball joint	1
K901		MN60A0950	レバークミタテ	Lever assy.	1

□ 糸切り機構 (Ⅱ)
THREAD TRIMMING MECHANISM (Ⅱ)

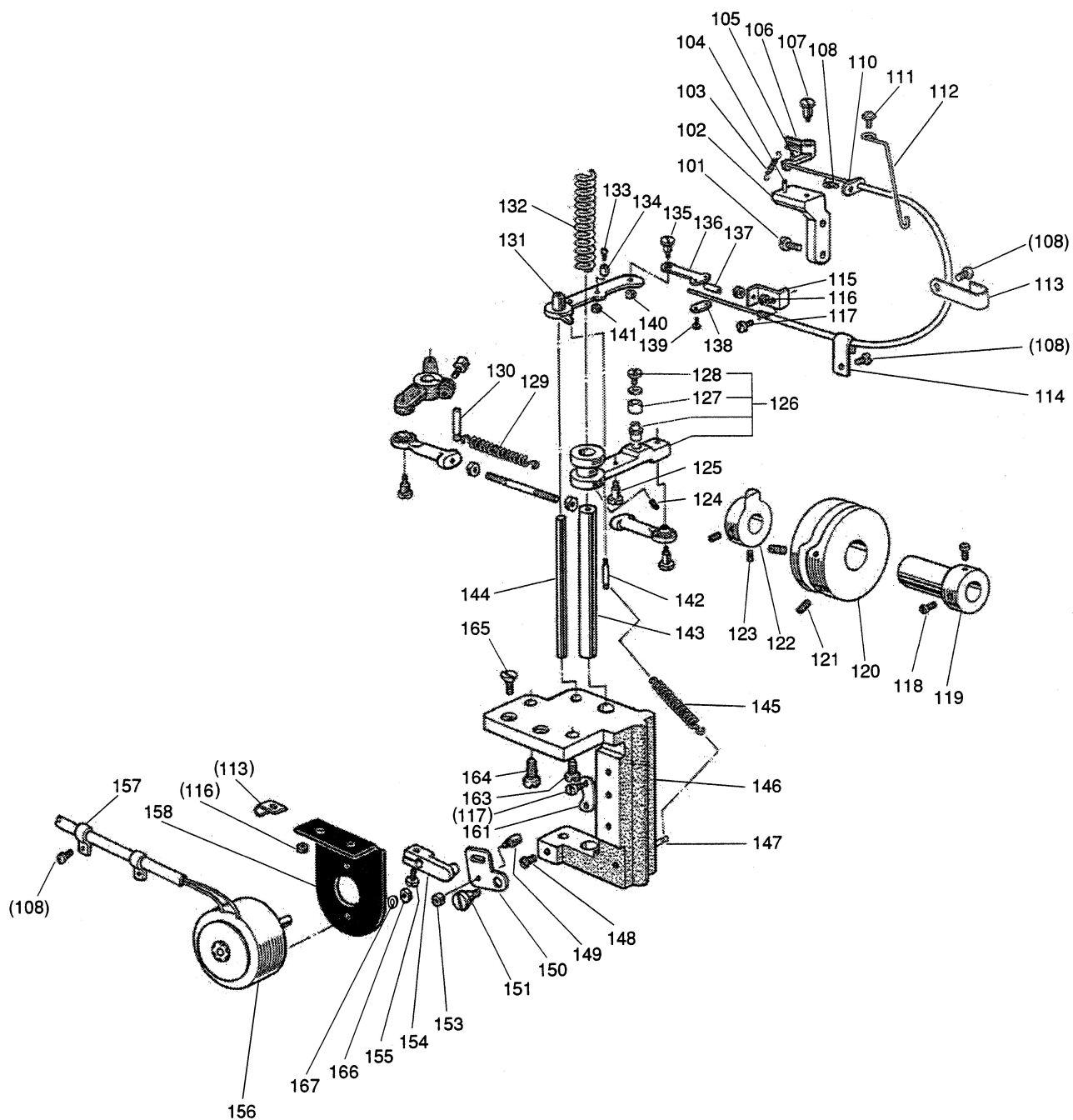

[L] 系切り機構 (II)
 THREAD TRIMMING MECHANISM (II)

Fig. No.	変更 Mod.	部品コード Parts. No.	部品名	Description	使用個数 Amt. Req.
					B1T
L101		M91110002	ヒラネジ	Screw 11/64(40) × 8	2
L102		MN60A0172	イトルメダイ	Thread releasing bracket	1
L103		MN60A6572	ツルマキバネ	Spring	1
L104	C	M91005067	ミゾツキピン BXカク	Pin type BX 2.5X12	1
L105	C	M91004067	ミゾツキピン BXカク	Pin type BX 2.5X8	1
L106		MN60A0173	イトルメ	Thread releasing plate	1
L107		M91112015	ヒラネジ ダンツキ	Screw 11/64(40) × 5	1
L108		M91106004	フロマイネジ	Screw 11/64(40) × 8	4
L110	C	MP66E0746	フレキシブルワイヤクミタテ	Flexible wire assy.	1
L111		M91109004	ザカネツキフロマイネジ	Screw 11/64(40) × 9	1
L112		MP66A0780	ホルダ	Holder	1
L113	C	MN50A0780	ホルダ	Holder	2
L114		M94003099	ナイロンクリップ AB-3N	Nylon clip AB-3N	1
L115		MN60A0601	トリツケイタ	Mounting plate	1
L116	C	M91373045	ナット M5	Nut M5	4
L117	C	M91109002	ヒラネジ	Screw 11/64(40) × 7	3
L118		M91516002	ヒラネジ	Screw 15/64(28) × 8.5	2
L119		MN50A0750	ブッシュ	Bushing	1
L120		MP69A0350	イトキリカム	Thread Trimmer Cam	1
L121		M91602020	ロツカクアナツキトメネジ	Screw 1/4(40) × 10	2
L122		MN72A0350	カム	Cam	1
L123		M91055020	ロツカクアナツキトメネジ	Screw M4 × 4	2
L124		M91001020	ロツカクアナツキトメネジ	Screw 11/64(40) × 5	2
L125		M91111015	ヒラネジ ダンツキ	Screw (40) × 5.5	1
L126		MN60A0886	ヨウトウウテクミタテ	Crank for knife driving	1
L127		MN50A1411	コロ	Roller	1
L128		M90816002	ヒラネジ	Screw 1/8(44) × 4.5	1
L129		MP66A1572	ツルマキバネ	Spring	1
L130	C	M95007067	ミゾツキピン BXカク	Pin type BX φ5 × 14	1
L131		MN60E0950	イトルメレバークミタテ	Thread releasing lever	1
L132		MN60A5572	ツルマキバネ	Spring	1
L133		M91131015	ヒラネジ ダンツキ	Screw 11/64(40) × 3.6	1
L134		MN50A0411	コロ	Roller	1
L135		M91231015	ヒラネジ ダンツキ	Screw 3/16(28) × 5	1
L136		MN72A1601	トリツケイタ	Mounting plate	1
L137		MN72A1750	ブッシュ	Bushing	1
L138		MF36A0750	ブッシュ	Bushing	1
L139	C	M90825002	ヒラネジ	Screw 1/8(44) × 10	2
L140		M91201045	ナット	Nut 3/16(28) × 3	1
L141		M91107045	ナット	Nut 11/64(40)	1
L142		M91111030	トクシユネジ	Screw (40) × 4	1
L143		MN50A3454	ジク	Shaft	1
L144		MN60A0454	ジク	Shaft	1
L145		MN50A3572	ツルマキバネ	Spring	1
L146		MP66A0603	トリツケイタ	Set plate	1
L147		M95003067	ミゾツキピン BXカク	Pin type BX φ5 × 24	1
L148		M91102002	ヒラネジ	Screw 11/64(40) × 8.5	1
L149		M91111033	ピンネジ	Screw 11/64(40) × 6	1
L150		MN50A3950	レバ	Lever	1
L151		M91103016	マルヒラネジ ダンツキ	Screw (40) × 6.8	1
L153	C	M91101045	ナット	Nut 11/64(40)	1
L154	C	MP61E0228	ウテクミタテ	Arm assy.	1
L155		M91112002	ヒラネジ	Screw 11/64(40) × 12	1
L156		MP61E0519	ソレノイドクミタテ	Solenoid assy.	1
L157		MF10A0689	ホルダ	Holder	2
L158		MN50A3601	トリツケイタ	Mounting plate	1
L161		MN50A0477	ストッパ	Stopper	1
L163		M91602003	マルヒラネジ	Screw 1/4(24) × 13	1
L164		M91603003	マルヒラネジ	Screw 1/4(24) × 16	1
L165		M95001037	Pサラネジ	Screw M5 × 16	2
L166	C	M91002045	ナット	Nut M4	2
L167	C	M90401053	ハネサカネ	Spring washer 4	2

M 制御装置部分
CONTROL DEVICE COMPONENTS

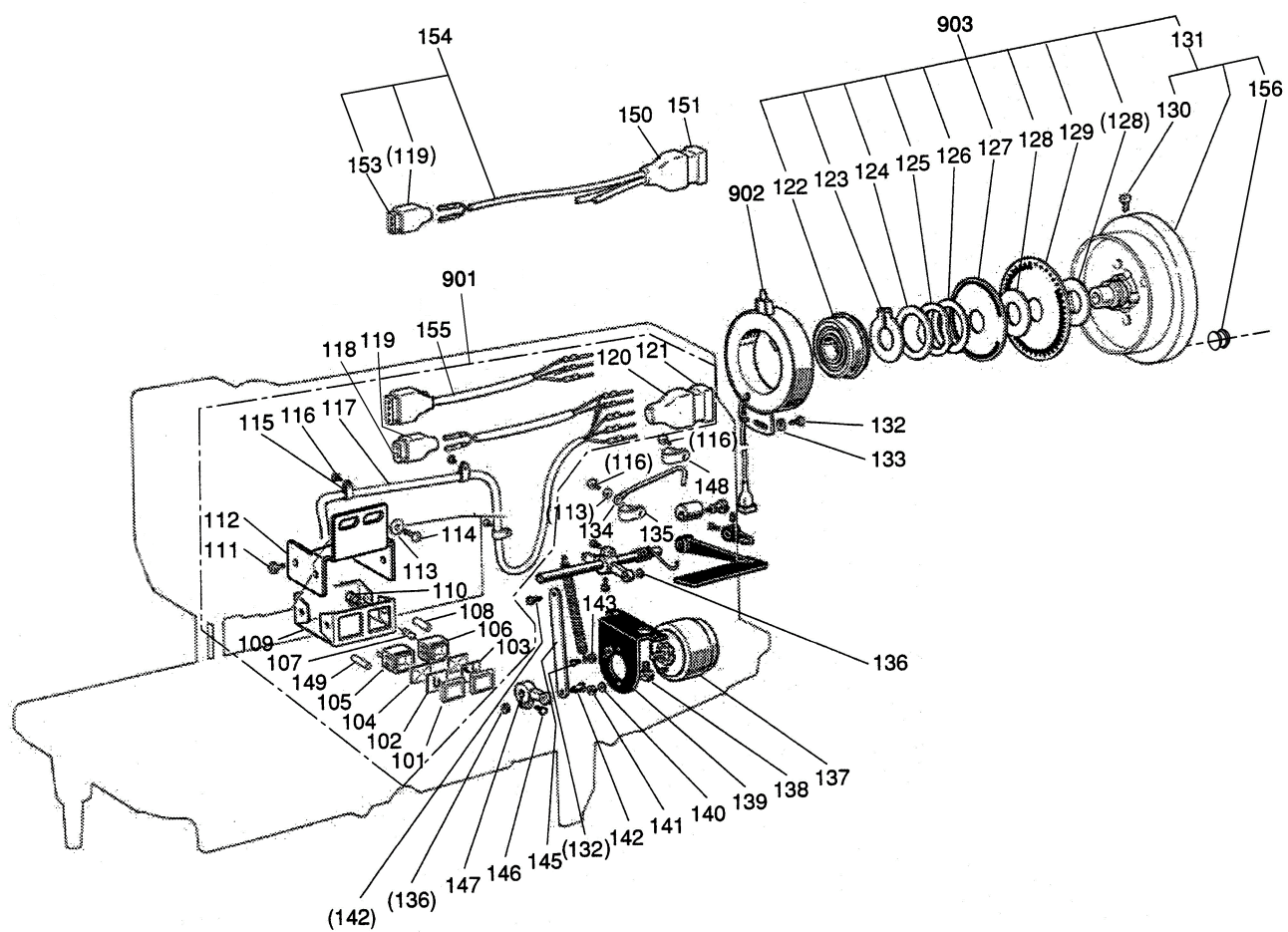

[M] 制御装置部分
CONTROL DEVICE COMPONENTS

Fig. No.	変更 Mod.	部品コード Parts. No.	部品名	Description	使用個数 Amt. Req.
					B1T
M101		MP47A0794	ボタン	Button	2
M102		MP47A0797	フィルム	Film	1
M103		MP47A1797	フィルム	Film	1
M104		MP47A0965	レンズ	Lens	2
M105		MP47A1484	スイッチ	Switch	1
M106	C	MP47A0484	スイッチ	Switch	1
M107		M91005094	テコウキ	Resistor 1W 220Ω	1
M108		MQ40A0567	シリコンチューブ	Tube	5
M109		MP47A1601	スイッチトリツケイタシタ	Mounting plate lower	1
M110	C	MP47A2620	バンド SKB-1M	Band SKB-1M	1
M111		M90859004	SW-PWツキ Pナベネジ	Screw M3×6	4
M112		MP67A0601	スイッチトリツケイタウエ	Mounting plate upper	1
M113		M90421050	ミガキサガネ	Washer	3
M114		M91110004	ブラマイネジ	Screw 11/64(40)×8	2
M115	C	MS14A1620	ナイロンクリップ AB-4N	Nylon clip AB-4N	3
M116		M91111008	ブラマイネジ	Screw 11/64(40)×10	5
M117		MP47A0508	コードクミタテ(OP-B)	Code assy. (OP-B)	1
M118		MP47A1422	コネクタ	Connector 2P	1
M119	C	MP47A0366	コネクタキャップ	Connector cap	2
M120		MQ40A0366	コネクタキャップ	Connector cap	1
M121		MP47A0422	コネクタ	Connector 15P	1
M122		MN10A1456	シクウケ 6204ZZNR	Ball bearing	1
M123		M90330065	Cカトメワシクヨウ 30	Retaining ring C-type 30	1
M124		M93001050	サガネ	Washer	1
M125		MF01A0259	ハンシャパンオサエスプリング	Supporter spring	1
M126		MF01A1476	スペーサ B	Spacer B	1
M127		MN72A1694	ハンシャパン F20	Speed command disk F20 (up)	1
M128		MF01A0476	スペーサ A	Spacer A	2
M129		MN82A0694	ハンシャパン F11	Speed command disk F11 (down)	1
M130		M91520002	ヒラネジ	Screw 15/64(28)×12	2
M131		MP67A0682	プーリクミタテ	Pulley assy.	1
M132	C	M91106004	ブラマイネジ	Screw 11/64(40)×8	2
M133		M93002050	サガネ	Washer	1
M134		M97085095	アースセンクミタテ	Ground wire assy.	1
M135		MN60A0620	ナイロンクリップ AB-5N	Nylon clip AB-5N	1
M136		M91502045	ナット	Nut 15/64(28)	2
M137		MN72E1519	ソレノイドクミタテ	Solenoid assy.	1
M138		M98005022	ボルト	Bolt M8×12	2
M139		MP47A2601	トリツケイタ	Mounting plate	1
M140		M90601053	ハネサガネ	Spring washer 6	2
M141	C	M91576045	ナット	Nut M6	2
M142		M91517015	ヒラネジ タンツキ	Screw 15/64(28)×14	2
M143	C	M91101045	ナット	Nut 11/64(40)	1
M145		MN50A2910	リンク	Link	1
M146		M91502022	ボルト	Bolt 15/64(28)×13	1
M147		MN50A5228	ウテ	Crank	1
M148		MB60A1620	ナイロンクリップ AB-8N	Nylon clip AB-8N	1
M149		MP47A2567	シリコンチューブ	Tube	1
M150	C	MG68A0366	コネクタキャップ	Connector cap	1
M151		M91018099	コネクタ	Connector 12P	1
M153		MP66A0422	コネクタ	Connector 3P	1
M154	C	MP47A1508	コードクミタテ	Code assy.	1
M155	C	MP67A0508	コードクミタテ	Code assy.	1
M156	C	MP60A0750	ブッシュA	Bushing	1
M901	C	MP52E0485	スイッチボックスクミタテ	Switch box assy.	1
M902	C	ME20A0406	ケンシュツキクミタテ	Detector bracket assy.	1
M903		MP67E0682	プーリクミタテ	Pulley assy.	1

N 給油機構
OIL LUBRICATION MECHANISM

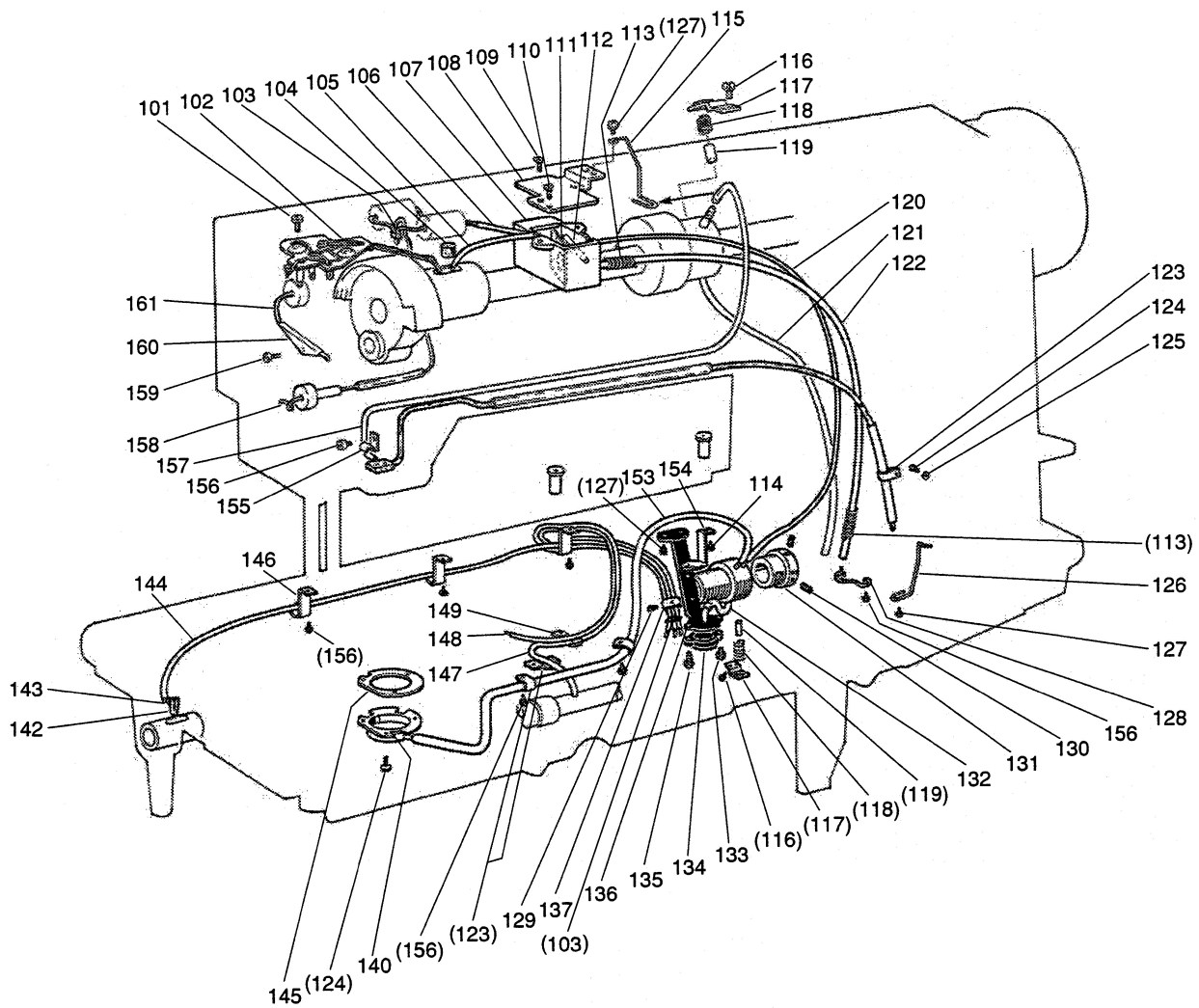

[N] 給油機構
OIL LUBRICATION MECHANISM

Fig. No.	変更 Mod.	部品コード Parts. No.	部品名	Description	使用個数 Amt. Req.
					B1T
N101		M90939002	ヒラネジ	Screw 9/64(40)×11	2
N102		MP47A6601	トリツケイタヒモクミタテ	Oil braid fitting plate	1
N103	C	MF80A0780	ホルダ	Clip	2
N104		MP40A3740	フェルト	Felt	1
N105		MP66E0688	ハ イフ ヒモクミタテ	Oil pipe wick assy.	1
N106		MP66E1688	ハ イフ ヒモクミタテ	Oil pipe wick assy.	1
N107		MN70E0138	オイルタンククミタテ	Oil reservoir assy.	1
N108		MP47A4601	トリツケイタ	Mounting plate	1
N109	D	M91069004	フ ラマイネジ	Screw M4×8	2
N110		M91106004	フ ラマイネジ	Screw 11/64(40)×8	1
N111	C	MN70A0780	ホルダ	Holder	1
N112		M90103064	ス プ リング ピ ン	Spring pin 1.6×10	1
N113		MP47A2572	ツルマキハネ	Coil spring	2
N114	C	M91120004	ザ カ ネツキフ ラマイネジ	Screw 11/64(40)×6.5	1
N115	C	MP47A3780	ホルダ	Holder	1
N116		M90805002	ヒラネジ	Screw 1/8(44)×4.8	2
N117		MN40A0705	ハ ネオサエ	Spring holder	2
N118		MN40A1572	ツルマキハネ	Spring	2
N119		M95007063	トクシユピ ン	Pin	2
N120		MP47A2688	ハ イフ	Oil pipe φ3×1×385	1
N121		MP47A1688	ハ イフ	Oil pipe φ3×1×320	1
N122		MP47A0688	ハ イフ	Oil pipe φ5×1×385	1
N123	C	MF10A0689	ホルダ	Holder	4
N124	C	M90903002	ヒラネジ	Screw 9/64(40)×6.5	4
N125		M90304053	ハ ネサ ガ ネ 3.5	Spring washer 3.5	1
N126		MP60A1689	ホルダ	Holder	1
N127		M91109004	ザ カ ネツキフ ラマイネジ	Screw 11/64(40)×8	4
N128		MP60A2689	ホルダ	Holder	1
N129		M90906002	ヒラネジ	Screw 9/64(40)×4.5	1
N130		M91111001	トメネジ	Screw 11/64(40)×10	2
N131		MP47A3750	フ ツシユ	Bushing	1
N132		MP40A2688	ハ イフ	Oil pipe φ3×1×90	1
N133		M90944003	マルヒラネジ	Screw 9/64(40)×5	1
N134		MP60A0337	フィルタクミタテ	Filter assy.	1
N135		M90905003	マルヒラネジ	Screw 9/64(40)×7	1
N136		MP60E0601	トリツケイタ クミタテ	Mounting plate assy.	1
N137		MP40A4689	ホルダ	Holder	1
N140		MN50E0742	フタクミタテス	Oil reservoir assy.	1
N142		MF10E2148	ヒモ	Oil wick φ2.5×65	2
N143		MF10E2148	ヒモ	Oil wick φ2.5×545	1
N144		MP40A5688	ハ イフ	Oil pipe φ3×0.5×380	1
N145	C	MP60A0691	ガ スケット	Gasket	1
N146		MN70A5780	ホルダ	Holder	2
N147		MP66E2688	ハ イフ ヒモクミタテ	Oil pipe wick assy.	1
N148		MP66E3688	ハ イフ ヒモクミタテ	Oil pipe wick assy.	1
N149		MQ60A2780	ホルダ	Holder	1
N153		MP66A0688	ハ イフ	Oil pipe φ3×1×430	1
N154		MQ60A0429	ササエイタ	Holding plate	1
N155		MN70A0689	ホルダ	Holder	1
N156		M91107002	ヒラネジ	Screw 11/64(40)×5.5	8
N157		MP66E0740	カンユフエルトクミタテ	Felt assy.	1
N158		MP47E2148	ハ イフ ヒモクミタテ	Oil pipe wick assy.	1
N159		M90802003	マルヒラネジ	Screw 1/8(44)×4.5	1
N160		MP66A1780	ホルダ	Oil wick holder	1
N161		MP47A0148	ヒモ	Oil wick φ2×450	1

P 付属品
ACCESSORIES

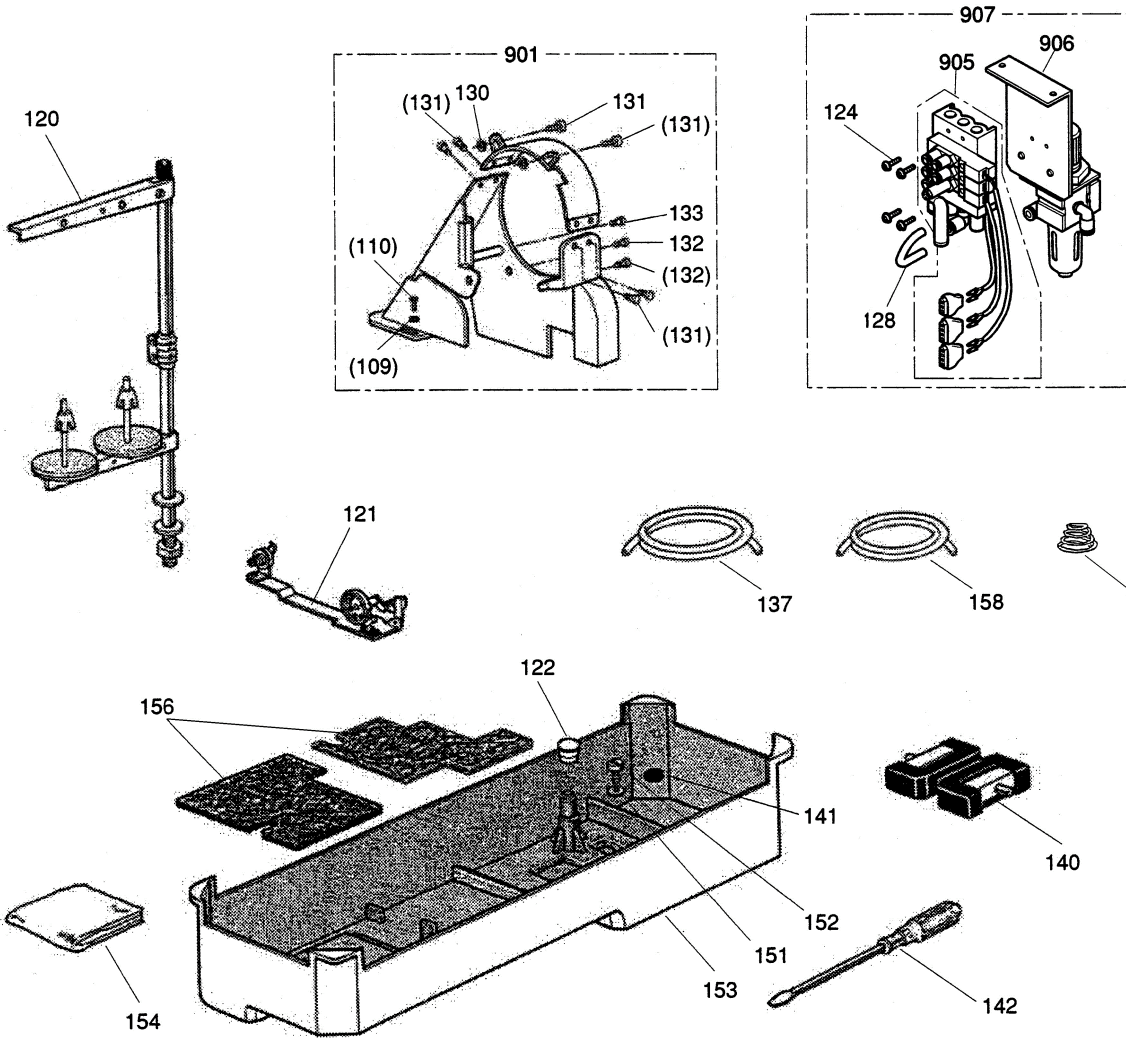
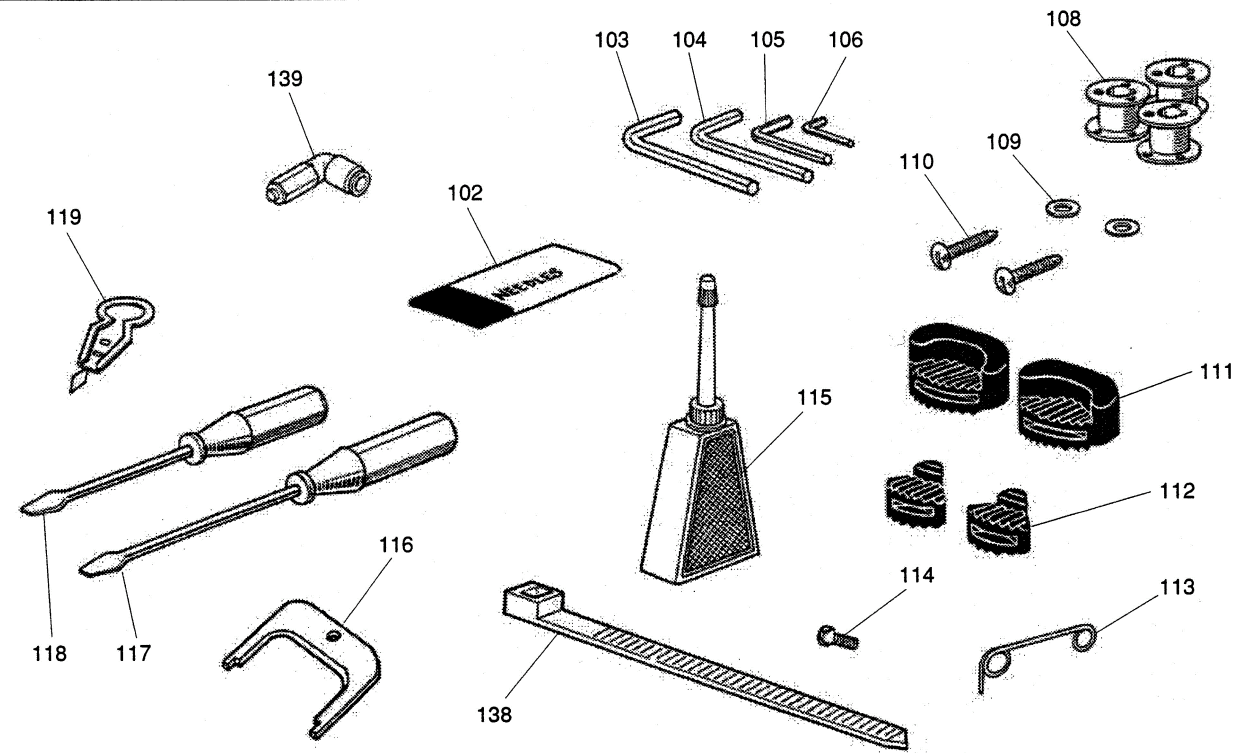

[P] 付属品
ACCESSORIES

Fig. No.	変更 Mod.	部品コード Parts. No.	部品名	Description	使用個数 Amt. Req.
					B1T
P102	C	ML75A0128	ミシンハリ DP×17-21	Needle DP×17-21	3
P103		MS01A1976	ロツカクホ ^ウ スハ ^ナ 4	Socket wrench 4	1
P104		MS02A2976	ロツカクホ ^ウ スハ ^ナ 3	Socket wrench 3	1
P105		MS02A1976	ロツカクホ ^ウ スハ ^ナ 2.5	Socket wrench 2.5	1
P106		MS02A0976	ロツカクホ ^ウ スハ ^ナ 2	Socket wrench 2	1
P108		MP60A0123	ボ ^ヒ ン	Bobbin	3
P109		M90511050	ミガ ^キ ザ ^ガ ネ	Washer	4
P110		M90409041	マルモクネジ	Screw 4.5×20	6
P111		MN70A0419	ボ ^ウ シンゴ ^ム	Vibration preventing rubber	2
P112		MN70A1419	ボ ^ウ シンゴ ^ム	Vibration preventing rubber	2
P113		MN82A0180	イトアンナイ	Thread guide	1
P114		M90305037	ナ ^ハ ネジ	Screw M3×6	1
P115		MF60A0137	ア ^フ ラサシ	Oiler	1
P116		MF01A0565	カク ^ト チヨウセイク	Adjusting plate for speed command disk	1
P117	D	MF06A0608	ネジ ^マ ワシ(チユウ)	Screw driver (middle)	1
P118	D	MF06A1608	ネジ ^マ ワシ(シヨウ)	Screw driver (small)	1
P119	C	MP47A0172	イトトオシキクミタテ	Thread a needle kit	1
P120	C	MH10E0193	イトタテアイ	Cotton stand	1
P121	C	MF08E0190	イトマキシカケ	Bobbin winder	1
P122		M90883080	ゴ ^ム セン	Rubber plug φ8.8	1
P124		M91066004	SW-PW フ ^ラ マイナ ^ハ ネジ	Screw M4×25	4
P128		MB20P1567	エ ^ア チユーブ	Tube	1
P130		M90453050	ザ ^ガ ネ	Washer 4.3	1
P131	C	M91120004	ザ ^ガ ネツキフ ^ラ マイネジ	Screw 11/64(40)×6.5	6
P132		M91508004	フ ^ラ マイネジ	Screw 15/64(28)×8	2
P133	C	M91075004	SW-PWツキ ^ナ ハ ^ネ ジ	Screw M4×14	1
P137		MP66E0567	エ ^ア チユーブ	Urethane Tube	2
P138	A	MB60A0201	ケツツクハ ^ン ト	Cable tie	1
P139		MP66A0571	ロンク ^{エル} ホ ^{ユニ} オン	Connector	2
P140		MF01E0418	チヨウハ ^ン セット	Hinge assy.	2
P141		M90701099	OP-S ジ ^ン ヤク	Magnet block for reservoir	1
P142		MF00A0608	ネジ ^マ ワシ(タ ^イ)	Screw driver large	1
P151		M97001052	トクシユザ ^ガ ネ	Washer	1
P152		M92002002	ヒラネジ	Screw 5/16(28)×10	1
P153		MP66A0139	ア ^フ ラソウ	Oil reservoir	1
P154	D	MP60A0734	ビ ^ニ ールカバ ^ー	Vinyl cover	1
P156	C	MN70E0740	フェルトクミタテ	Felt assy.	1
P158	C	MP47A1567	エ ^ア チユーブ	Urethane Tube	2
P159	C	MN52A1245	エ ^ン スイハ ^ネ	Spring	1
P901		MP70E1776	ベ ^ル トカバ ^ー セット	Belt cover assy.	1
P905		MP52E0599	デ ^ン ジ ^ベ ン ^ア センブ ^リ	Solenoid valve assy.	1
P906		MP52E0963	レ ^キ ユレ ^タ クミタテ	Solenoid valve assy.	1
P907		MP52E1599	レ ^キ ユレ ^タ クミタテ ^ン ジ ^ベ ン ^ク ミタテ	Solenoid valve assy.	1

索引 (I)
INDEX (I)

部品コード Parts. No.	ページ Page	Fig. No.	部品コード Parts. No.	ページ Page	Fig. No.	部品コード Parts. No.	ページ Page	Fig. No.	部品コード Parts. No.	ページ Page	Fig. No.
M90103064	P27	N112	M90906002	P27	N129	M91111004	P11	E130	M91513022	P17	H154
M90107024	P11	E126	M90906010	P21	K119	M91111004	P25	M116	M91515002	P07	C132
M90304053	P27	N125	M90907010	P21	K104	M91111015	P23	L125	M91516001	P07	C141
M90305037	P29	P114	M90909003	P05	B119	M91111030	P23	L142	M91516001	P17	H111
M90310064	P07	C109	M90910003	P05	B139	M91111033	P21	K126	M91516002	P15	G102
M90317065	P17	H119	M90910003	P19	J115	M91111033	P23	L149	M91516002	P23	L118
M90330065	P25	M123	M90911030	P21	K101	M91112002	P11	E116	M91516015	P15	G114
M90335065	P17	H148	M90915003	P05	B128	M91112002	P23	L155	M91517015	P25	M142
M90401050	P19	J116	M90920002	P03	A147	M91112004	P03	A103	M91519002	P15	G117
M90401053	P23	L167	M90927015	P05	B104	M91112015	P23	L107	M91520002	P25	M130
M90401061	P09	D102	M90928015	P05	B137	M91116002	P03	A108	M91552015	P17	H133
M90409041	P29	P110	M90939002	P27	N101	M91120004	P27	N114	M91572045	P17	H131
M90421050	P25	M113	M90944002	P21	K109	M91120004	P29	P131	M91576045	P03	A106
M90429060	P03	A110	M90944003	P13	F125	M91128003	P03	A125	M91576045	P25	M141
M90453050	P29	P130	M90944003	P27	N133	M91131015	P23	L133	M91601003	P03	A127
M90501053	P19	J113	M90949003	P09	D137	M91201011	P03	A150	M91602001	P07	C115
M90504065	P13	F110	M91000085	P15	G127	M91201020	P19	J119	M91602001	P11	E120
M90505065	P05	B108	M91001020	P23	L124	M91201045	P19	J126	M91602001	P17	H118
M90505065	P17	H108	M91001050	P19	J120	M91201045	P23	L140	M91602001	P19	J129
M90511050	P29	P109	M91002045	P23	L166	M91204003	P17	H144	M91602003	P23	L163
M90511056	P07	C157	M91004067	P23	L105	M91205030	P19	J125	M91602020	P23	L121
M90513065	P07	C125	M91005067	P23	L104	M91215002	P15	G120	M91603001	P17	H105
M90516060	P05	B140	M91005094	P25	M107	M91219015	P07	C107	M91603001	P19	J132
M90516065	P11	E113	M91010004	P27	N109	M91231015	P23	L135	M91603003	P09	D111
M90519050	P15	G141	M91018099	P25	M151	M91252045	P19	J114	M91603003	P17	H135
M90526065	P17	H115	M91055020	P23	L123	M91260030	P19	J110	M91603003	P23	L164
M90533060	P13	F111	M91066004	P29	P124	M91271015	P21	K132	M91606001	P07	C163
M90573080	P13	F135	M91075004	P29	P133	M91304080	P03	A142	M91606001	P09	D117
M90601053	P25	M140	M91101045	P05	B110	M91305080	P03	A153	M91610046	P05	B125
M90602002	P09	D118	M91101045	P23	L153	M91373045	P23	L116	M91611046	P05	B126
M90602050	P17	H132	M91101045	P25	M143	M91374045	P21	K134	M91652002	P19	J123
M90604011	P09	D104	M91101046	P05	B117	M91377045	P21	K136	M91652020	P03	A107
M90605002	P21	K111	M91102002	P15	G110	M91382045	P07	C160	M91654001	P17	H137
M90605063	P07	C123	M91102002	P23	L148	M91501007	P07	C118	M91655001	P19	J131
M90607050	P19	J122	M91102015	P11	E125	M91502002	P07	C116	M91681015	P13	F128
M90617063	P07	C128	M91103001	P13	F130	M91502002	P09	D108	M91801002	P07	C164
M90631050	P17	H155	M91103016	P23	L151	M91502022	P25	M146	M91802006	P07	C165
M90701099	P29	P141	M91104011	P03	A132	M91502045	P09	D115	M91910080	P03	A104
M90801010	P21	K108	M91106001	P11	E110	M91502045	P25	M136	M92002002	P29	P152
M90802001	P05	B131	M91106004	P05	B111	M91503001	P07	C134	M93001050	P25	M124
M90802003	P27	N159	M91106004	P15	G136	M91503001	P11	E104	M93002050	P25	M133
M90803020	P17	H151	M91106004	P23	L108	M91503001	P19	J127	M93202047	P13	F102
M90804016	P03	A143	M91106004	P25	M132	M91503007	P07	C131	M93222035	P13	F101
M90805002	P27	N116	M91106004	P27	N110	M91503031	P07	C150	M94001001	P07	C143
M90810002	P17	H160	M91106022	P21	K102	M91503031	P11	E137	M94003099	P23	L114
M90816002	P23	L128	M91107002	P27	N156	M91503031	P15	G142	M95001021	P11	E140
M90823002	P09	D122	M91107045	P23	L141	M91505002	P11	E108	M95001037	P23	L165
M90825002	P23	L139	M91108001	P07	C149	M91505002	P15	G109	M95002017	P15	G139
M90851015	P07	C140	M91108001	P11	E102	M91505004	P07	C153	M95002067	P07	C112
M90859004	P25	M111	M91108002	P13	F116	M91505007	P15	G103	M95003067	P23	L147
M90883080	P29	P122	M91109002	P23	L117	M91506001	P07	C135	M95004017	P15	G144
M90902011	P17	H123	M91109004	P03	A115	M91506001	P13	F104	M95004020	P03	A113
M90902015	P05	B101	M91109004	P09	D124	M91506001	P15	G115	M95004021	P17	H152
M90903002	P27	N124	M91109004	P23	L111	M91506002	P11	E128	M95007063	P27	N119
M90903010	P03	A130	M91109004	P27	N127	M91507015	P09	D114	M95007067	P23	L130
M90903010	P21	K106	M91110002	P23	L101	M91508004	P29	P132	M95008020	P15	G130
M90904011	P03	A136	M91110004	P03	A141	M91508030	P11	E121	M95010023	P21	K135
M90904060	P15	G105	M91110004	P25	M114	M91509002	P19	J102	M95014021	P15	G129
M90905003	P27	N135	M91111001	P13	F126	M91509022	P21	K131	M95045021	P07	C158
M90906002	P05	B106	M91111001	P27	N130	M91513001	P07	C136	M96062021	P15	G138

索引 (Ⅱ)

INDEX (Ⅱ)

部品コード Parts. No.	ページ Page	Fig. No.	部品コード Parts. No.	ページ Page	Fig. No.	部品コード Parts. No.	ページ Page	Fig. No.	部品コード Parts. No.	ページ Page	Fig. No.
M97001052	P29	P151	MN10A0131	P03	A152	MN60A0601	P23	L115	MP40A5688	P27	N144
M97008060	P05	B120	MN10A0292	P17	H104	MN60A0620	P25	M135	MP40E0453	P17	H116
M97085095	P25	M134	MN10A0302	P19	J109	MN60A0837	P21	K118	MP41A0245	P05	B123
M98005022	P25	M138	MN10A0343	P19	J121	MN60A0886	P23	L126	MP41A0270	P17	H110
MB20P1567	P29	P128	MN10A0476	P03	A151	MN60A0950	P21	K901	MP41A0572	P17	H109
MB60A0201	P29	P138	MN10A0500	P09	D130	MN60A2228	P21	K130	MP41A1270	P05	B114
MB60A1620	P25	M148	MN10A0771	P17	H122	MN60A2572	P15	G107	MP41B0838	P21	K107
MB62A0975	P21	K137	MN10A0851	P05	B103	MN60A2742	P21	K116	MP41E0642	P19	J130
ME20A0406	P25	M902	MN10A1456	P25	M122	MN60A5572	P23	L132	MP41E0644	P19	J902
MF00A0257	P15	G121	MN10A1476	P09	D105	MN60A6572	P23	L103	MP42A0740	P17	H159
MF00A0608	P29	P142	MN10A1851	P07	C119	MN60E0154	P21	K117	MP46A0181	P09	D121
MF00A0852	P15	G119	MN10A2456	P17	H121	MN60E0950	P23	L131	MP47A0148	P27	N161
MF00A0950	P15	G124	MN10A4742	P03	A123	MN70A0154	P05	B130	MP47A0152	P03	A114
MF01A0259	P25	M125	MN10A6740	P07	C106	MN70A0308	P05	B135	MP47A0172	P29	P119
MF01A0476	P25	M128	MN10E0301	P19	J901	MN70A0352	P09	D116	MP47A0180	P05	B118
MF01A0565	P29	P116	MN12B0342	P19	J118	MN70A0387	P09	D131	MP47A0234	P07	C113
MF01A0631	P15	G123	MN40A0180	P03	A105	MN70A0419	P29	P111	MP47A0252	P13	F120
MF01A1476	P25	M126	MN40A0273	P17	H141	MN70A0477	P05	B129	MP47A0267	P13	F103
MF01E0418	P29	P140	MN40A0325	P17	H125	MN70A0554	P05	B138	MP47A0281	P17	H153
MF02A0245	P15	G125	MN40A0454	P17	H126	MN70A0573	P05	B127	MP47A0286	P11	E103
MF06A0608	P29	P117	MN40A0456	P17	H114	MN70A0689	P27	N155	MP47A0291	P15	G101
MF06A1608	P29	P118	MN40A0669	P09	D110	MN70A0750	P05	B132	MP47A0305	P07	C137
MF08E0190	P29	P121	MN40A0705	P27	N117	MN70A0780	P27	N111	MP47A0359	P09	D123
MF10A0555	P05	B121	MN40A1325	P09	D107	MN70A1419	P29	P112	MP47A0366	P25	M119
MF10A0689	P23	L157	MN40A1454	P17	H130	MN70A1553	P05	B112	MP47A0422	P25	M121
MF10A0689	P27	N123	MN40A1572	P27	N118	MN70A2252	P07	C148	MP47A0434	P11	E138
MF10A1555	P05	B115	MN40A1956	P17	H124	MN70A2750	P19	J103	MP47A0456	P13	F122
MF10A2572	P15	G118	MN42A0383	P07	C161	MN70A5780	P27	N146	MP47A0476	P13	F106
MF10E2148	P09	D125	MN45A0154	P15	G137	MN70E0138	P27	N107	MP47A0484	P25	M106
MF10E2148	P17	H150	MN45A0352	P15	G132	MN70E0175	P05	B136	MP47A0508	P25	M117
MF10E2148	P19	J107	MN50A0192	P21	K110	MN70E0740	P29	P156	MP47A0510	P07	C144
MF10E2148	P19	J108	MN50A0278	P17	H145	MN70E1148	P17	H107	MP47A0523	P07	C121
MF10E2148	P27	N142	MN50A0411	P23	L134	MN70E1175	P05	B134	MP47A0567	P11	E139
MF10E2148	P27	N143	MN50A0417	P15	G113	MN72A0350	P23	L122	MP47A0572	P13	F105
MF10E3148	P09	D129	MN50A0426	P03	A128	MN72A0632	P15	G112	MP47A0590	P13	F119
MF36A0245	P05	B116	MN50A0477	P23	L161	MN72A0950	P05	B105	MP47A0621	P11	E136
MF36A0750	P23	L138	MN50A0507	P21	K112	MN72A0975	P21	K133	MP47A0631	P03	A111
MF60A0137	P29	P115	MN50A0750	P23	L119	MN72A1601	P23	L136	MP47A0688	P27	N122
MF70A0286	P17	H136	MN50A0780	P23	L113	MN72A1694	P25	M127	MP47A0729	P11	E129
MF80A0352	P07	C114	MN50A0839	P21	K103	MN72A1750	P23	L137	MP47A0750	P13	F108
MF80A0352	P11	E119	MN50A1411	P23	L127	MN72A1950	P15	G116	MP47A0767	P07	C117
MF80A0352	P17	H138	MN50A2910	P25	M145	MN72E1519	P25	M137	MP47A0794	P25	M101
MF80A0780	P17	H147	MN50A3454	P23	L143	MN82A0180	P29	P113	MP47A0797	P25	M102
MF80A0780	P27	N103	MN50A3572	P23	L145	MN82A0694	P25	M129	MP47A0841	P03	A112
MF90A0640	P15	G126	MN50A3601	P23	L158	MPO0B0346	P07	C127	MP47A0886	P09	D112
MG23C6740	P17	H102	MN50A3950	P23	L150	MPO0B0643	P19	J133	MP47A0910	P11	E124
MG43A1181	P03	A138	MN50A4572	P05	B113	MPO0B0729	P07	C126	MP47A0965	P25	M104
MG68A0366	P25	M150	MN50A5228	P25	M147	MPO0B0871	P07	C122	MP47A1148	P13	F113
MG75A0285	P11	E118	MN50A6228	P15	G108	MPO0B0952	P07	C129	MP47A1228	P11	E123
MG75A0460	P11	E101	MN50A6601	P05	B107	MPO0B1750	P07	C130	MP47A1252	P07	C145
MG75A0572	P03	A109	MN50E0220	P05	B102	MPO0B1910	P07	C124	MP47A1359	P13	F118
MG75A2910	P11	E114	MN50E0742	P27	N140	MP40A0148	P17	H127	MP47A1422	P25	M118
MG75A4454	P11	E109	MN52A0300	P19	J117	MP40A0148	P17	H129	MP47A1454	P17	H149
MG75A6454	P11	E112	MN52A0301	P19	J112	MP40A0340	P19	J111	MP47A1476	P03	A122
MG75A6956	P11	E111	MN52A1245	P29	P159	MP40A0452	P17	H106	MP47A1484	P25	M105
MG75E0463	P11	E107	MN52A2245	P19	J105	MP40A0740	P15	G135	MP47A1508	P25	M154
MH10E0193	P29	P120	MN60A0172	P23	L102	MP40A1740	P15	G133	MP47A1567	P29	P158
MH40A0556	P05	B122	MN60A0173	P23	L106	MP40A2688	P27	N132	MP47A1572	P13	F107
ML75A0128	P09	D120	MN60A0411	P21	K114	MP40A3740	P27	N104	MP47A1601	P25	M109
ML75A0128	P29	P102	MN60A0454	P23	L144	MP40A4689	P27	N137	MP47A1688	P27	N121

索引 (Ⅲ)

INDEX (Ⅲ)

部品コード Parts. No.	ページ Page	Fig. No.	部品コード Parts. No.	ページ Page	Fig. No.	部品コード Parts. No.	ページ Page	Fig. No.	部品コード Parts. No.	ページ Page	Fig. No.			
MP47A1740	P17	H143	MP60E0305	P17	H901	MP67A0454	P13	F127
MP47A1797	P25	M103	MP60E0601	P27	N136	MP67A0473	P03	A129
MP47A1910	P13	F131	MP60E1582	P09	D902	MP67A0508	P25	M155
MP47A2148	P13	F124	MP60E1635	P15	G131	MP67A0587	P09	D126
MP47A2567	P25	M149	MP61A0187	P05	B133	MP67A0601	P25	M112
MP47A2572	P27	N113	MP61A0192	P03	A124	MP67A0682	P25	M131
MP47A2601	P25	M139	MP61A0729	P15	G111	MP67A0691	P03	A117
MP47A2620	P25	M110	MP61A0742	P03	A134	MP67A0740	P09	D134
MP47A2688	P27	N120	MP61A2601	P05	B109	MP67A0830	P03	A135
MP47A2750	P17	H117	MP61E0228	P23	L154	MP67A0880	P03	A116
MP47A2910	P13	F114	MP61E0519	P23	L156	MP67A1956	P09	D113
MP47A3148	P13	F117	MP66A0107	P13	F132	MP67A2120	P19	J104
MP47A3454	P11	E117	MP66A0139	P29	P153	MP67E0232	P07	C105
MP47A3750	P27	N131	MP66A0148	P17	H146	MP67E0666	P09	D901
MP47A3780	P27	N115	MP66A0228	P07	C111	MP67E0682	P25	M903
MP47A3910	P13	F121	MP66A0267	P07	C138	MP69A0101	P03	A131
MP47A4454	P13	F112	MP66A0345	P19	J101	MP69A0104	P17	H156
MP47A4601	P27	N108	MP66A0411	P07	C108	MP69A0350	P23	L120
MP47A5454	P13	F123	MP66A0422	P25	M153	MP69A0434	P15	G901
MP47A6601	P27	N102	MP66A0434	P07	C155	MP69A0838	P21	K105
MP47E0228	P11	E115	MP66A0450	P17	H103	MP69A0841	P15	G122
MP47E0352	P11	E105	MP66A0454	P07	C152	MP70E1776	P29	P901
MP47E0704	P13	F109	MP66A0470	P03	A133	MQ40A0366	P25	M120
MP47E0768	P07	C901	MP66A0477	P07	C159	MQ40A0567	P25	M108
MP47E1210	P05	B901	MP66A0491	P17	H142	MQ60A0429	P27	N154
MP47E1228	P11	E135	MP66A0559	P11	E122	MQ60A2780	P27	N149
MP47E1352	P13	F129	MP66A0571	P29	P139	MS01A1976	P29	P103
MP47E1787	P11	E131	MP66A0572	P07	C110	MS02A0976	P29	P106
MP47E2148	P27	N158	MP66A0600	P03	A102	MS02A1976	P29	P105
MP52A0228	P15	G146	MP66A0601	P07	C156	MS02A2976	P29	P104
MP52A0237	P03	A120	MP66A0603	P23	L146	MS14A1620	P25	M115
MP52A0320	P15	G106	MP66A0660	P09	D101	MT60A0802	P05	B124
MP52A0601	P15	G140	MP66A0688	P27	N153					
MP52A0603	P15	G145	MP66A0691	P03	A101					
MP52A0665	P09	D135	MP66A0738	P07	C146					
MP52A0910	P15	G143	MP66A0750	P03	A119					
MP52A0956	P09	D133	MP66A0780	P23	L112					
MP52E0485	P25	M901	MP66A0833	P11	E106					
MP52E0599	P29	P905	MP66A0881	P13	F115					
MP52E0963	P29	P906	MP66A1228	P11	E127					
MP52E1599	P29	P907	MP66A1572	P23	L129					
MP60A0123	P19	J106	MP66A1601	P07	C154					
MP60A0123	P29	P108	MP66A1780	P27	N160					
MP60A0148	P09	D132	MP66A1880	P03	A118					
MP60A0180	P03	A146	MP66A2691	P03	A121					
MP60A0202	P03	A145	MP66E0451	P17	H101					
MP60A0321	P15	G902	MP66E0567	P29	P137					
MP60A0337	P27	N134	MP66E0688	P27	N105					
MP60A0584	P03	A140	MP66E0740	P27	N157					
MP60A0691	P27	N145	MP66E0746	P23	L110					
MP60A0734	P29	P154	MP66E0768	P07	C133					
MP60A0744	P17	H158	MP66E1688	P27	N106					
MP60A0750	P25	M156	MP66E2688	P27	N147					
MP60A0761	P15	G128	MP66E3688	P27	N148					
MP60A0956	P15	G104	MP67A0230	P07	C120					
MP60A1689	P27	N126	MP67A0253	P07	C147					
MP60A2572	P03	A144	MP67A0262	P07	C139					
MP60A2689	P27	N128	MP67A0265	P07	C142					
MP60E0106	P07	C151	MP67A0279	P17	H134					
MP60E0180	P03	A901	MP67A0417	P09	D136					

オプションパーツ
Option parts

LU2-4652オプションパーツ OPTION PARTS

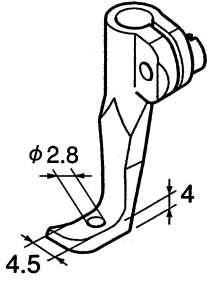
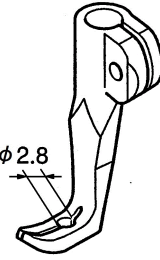
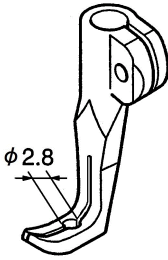
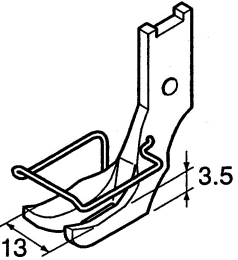
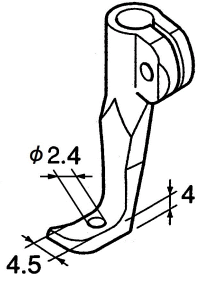
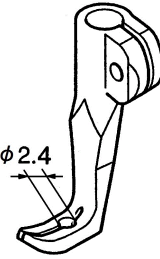
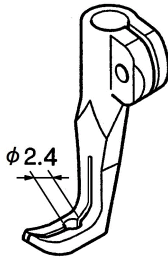
内押え Presser Foot (inside)			外押え Presser Foot (outside)
 <p>Technical drawing of Presser Foot MP60A3107. Dimensions: $\phi 2.8$, 4, 4.5.</p> <p>MP60A3107</p>	 <p>Technical drawing of Presser Foot MP66A0107. Dimension: $\phi 2.8$.</p> <p>MP66A0107</p>	 <p>Technical drawing of Presser Foot MP60A4107. Dimension: $\phi 2.8$.</p> <p>MP60A4107</p>	 <p>Technical drawing of Presser Foot MP60E0106. Dimensions: 3.5, 13.</p> <p>MP60E0106</p>
 <p>Technical drawing of Presser Foot MP60A5107. Dimensions: $\phi 2.4$, 4, 4.5.</p> <p>MP60A5107</p>	 <p>Technical drawing of Presser Foot MP66A1107. Dimension: $\phi 2.4$.</p> <p>MP66A1107</p>	 <p>Technical drawing of Presser Foot MP61A2107. Dimension: $\phi 2.4$.</p> <p>MP61A2107</p>	

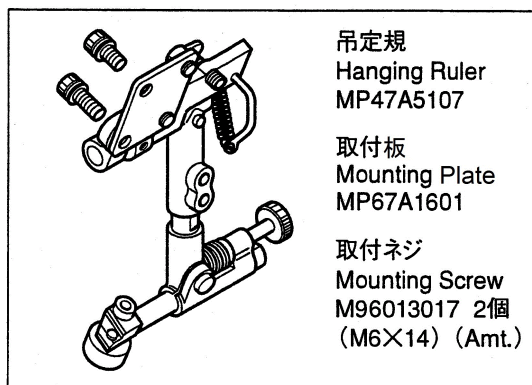

mitsubishi electric corporation

FACTORY AUTOMATION SYSTEM GROUP

2-7-3, Marunouchi Chiyoda-ku Tokyo 100-8310, Japan

Fax : +81-3-3218-6821