

# MITSUBISHI

## 三菱工業用ミシン部品カタログ

## Industrial Sewing Machine Parts Catalog

Model LS2-2210

	目次	CONTENTS	Page
A	本体関係	Arm bed & it's accessories .....	2
B	縫い機構 (I)	Sewing mechanism (I) .....	4
C	縫い機構 (II)	Sewing mechanism (II) .....	6
D	縫い機構(II)および水平送り軸 上下送り軸機構	Sewing mechanism (II) & Feed rock shaft, feed lifting Rock shaft mechanism .....	8
E	送り調節機構	Stitch length regulator mechanism .....	10
F	押え機構	Presser foot mechanism .....	12
G	糸切り機構	Knife actuating mechanism .....	14
H	タッチバック機構 および検出器機構	Touch back mechanism & Detector mechanism .....	16
J	ワイパー機構	Wiper mechanism .....	18
K	給油機構	Oil lubrication mechanism .....	20
L	付属品	Accessories .....	22
	索引	Index .....	24

# ミシン用部品コードの採番基準

## MITSUBISHI SPARE PARTS No. Designation system

注：※欄には英文字(A,B,...X,Y,Z)が入る。  
Remarks: Alphabet(A,B,...X,Y,Z) should be taken at ※ mark.

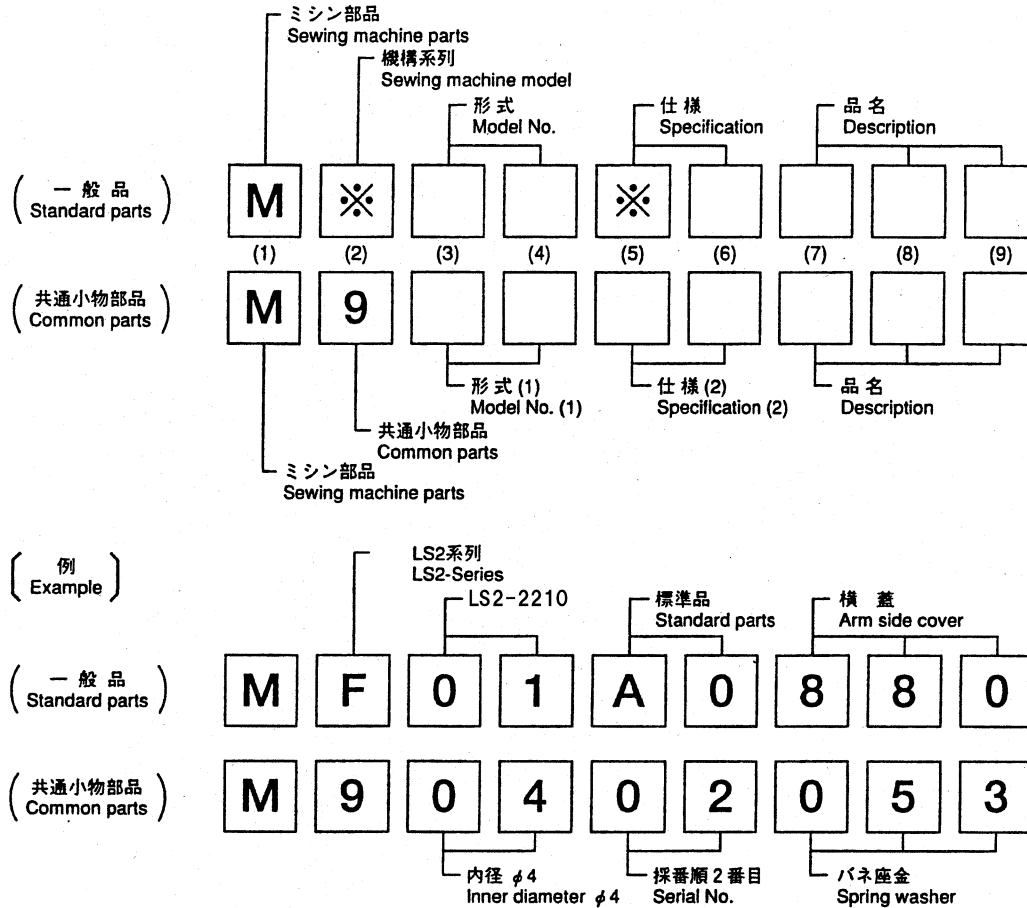

注：一般品についての機種形名は、その部品が最初に使用された機種形名を示します。従って長期に亘る場合は、機種の改廃が行われるため、当初の機種以外の機種で使用されている場合があります。  
Sewing machine Models, of Standard Parts are indicated model of these parts are registered firstly. Parts are used for not only the indicated model, but also another models, in reason of New development, improvement after.

### パーツカタログご利用に際して Information on use of the parts catalog

- 補用部品ご注文の際は、部品コードでご注文下さい。また、このパーツブックの管理番号と発行年月（表紙右下、例えば、P-1・・・201203）モデル機械番号を、合わせてご連絡頂ければ幸いです。
  - 一部の部品について、改良のため予告なしに変更になる場合がありますのでご了承下さい。
  - このパーツカタログは2012年3月のデータにもとづいて作成されたものです。
  - 部品コード欄が、—となっている部品は、補給いたしません。ただし組コードが記載されているものは、組部品として補給いたしますので、組コードでご注文下さい。
  - 使用個数欄の英数字組合せ文字は、このモデル番号のサブ機械番号をしめています。
  - 尚、本パーツブックの記載内容にお気付きの点がありましたら、お知らせ頂ければ幸いです。
- When ordering any spare part, please specify its part code. In addition, please specify the management number and issued date of this parts catalog (e. g. P-1・・・201203 indicated at bottom right of the front cover) and the machine model number.
  - Some parts are subject to change due to modification without notice.
  - This parts catalog is based the data as of Mar. 2012.
  - Any part marked-in the part code column will not be supplied. When a part has its assembly code, please specify the assembly code because that part is supplied as an assembly part.
  - Alphanumerical characters indicated in the required quantity column indicate the sub machine number of this model number.
  - Please write to us if you have any question on this parts catalog.

**A** 本体関係  
**ARM BED & IT'S ACCESSORIES**

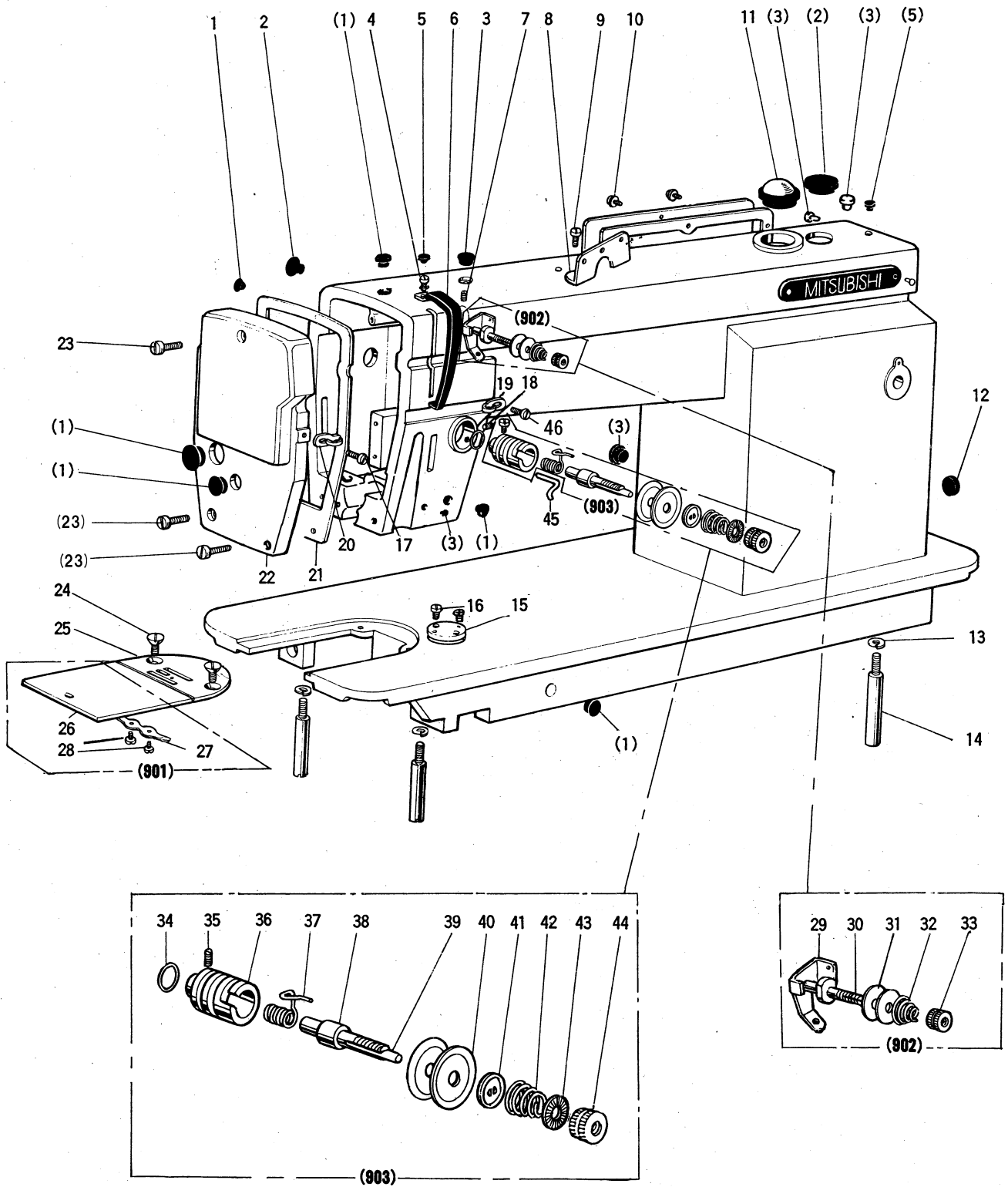

A 本体機構

ARM BED & IT'S ACCESSORIES

Fig. 変更		部品コード	部品名	Description	使用数
No.	Mod.	Parts.No.			Amt. Req.
A01		M91182080	ゴムセン	Rubber plug $\phi$ 11.8	6
A02		M91910080	ゴムセン	Rubber plug $\phi$ 19	2
A03		M90883080	ゴムセン	Rubber plug $\phi$ 8.8	5
A04		M91110004	ブライネジ	Screw 11/64(40)x8	1
A05		M90573080	ゴムセン	Rubber plug $\phi$ 5.7	2
A06		MN36A0584	テンビンカバー	Thread take-up cover	1
A07		M91108001	トメネジ	Set screw 11/64(40)x5.5	1
A08		MF36A1180	イトアンナイ	Thread guide (arm top)	1
A09		M91116002	ヒラネジ	Screw 11/64(40)x8	1
A10		M91109004	ザガネネジ	Screw 11/64(40)x8	6
A11		MF20A0135	アブラマド	Oil check window	1
A12		M92701080	セン	Rubber plug ( $\phi$ 27)	1
A13		M90106053	ハネサガネ6	Spring washer for leg 6	3
A14		MF10A0151	ササエ	Leg	3
A15		MF01A0601	トリツケイタ	Plate for guide	1
A16		M91107002	ヒラネジ	Screw 11/64(40)x5.5	2
A17		M90908003	マルヒラネジ	Screw 9/64(40)x6	1
A18		M91508001	トメネジ	Set screw 15/64(28)x6	1
A19		MF80A0181	イトアンナイ	Thread guide	1
A20		MF10A0181	イトアンナイ	Thread guide	1
A21		MN35A0691	ガスケット	Gasket for face plate	1
A22		MN36A0830	メンイタ	Face plate	1
A23		M91111004	ブライネジ	Screw 11/64(40)x10	3
A24		M91106011	マルサラネジ	Screw 11/64(40)x8	2
A25		MN35A1101	ハリイタ	Needle plate	1
A26		-	スベリイタ	Slide plate	1
A27		MF10A0471	イタハネ	Spring for slide plate	1
A28		M90604002	ヒラネジ	Screw 3/32(56)x2.4	2
A29		MF00A0181	イトアンナイ	Thread guide	1
A30		MF90A0553	チョウシホウ	Pre-tension stud	1
A31		MF10A1555	チョウシガラ	Tension discs for pre-tension	2
A32		MF36A0245	エンスイハネ	Pre-tension spring	1
A33		M91101046	ツマミナット	Pre-tension adjusting nut 11/64(40)	1
A34		M91501085	リング S15	O-ring S15	1
A35		M90901002	ヒラネジ	Screw 9/64(40)x4	1
A36		MF10A0709	ブツシュ	Thread tension regulator bushing	1
A37		MF10A0187	イトトリハネ	Thread take-up spring $\phi$ 0.6	1
A38		MF10A0553	チョウシホウ	Thread tension stud	1
A39		M90204060	ピン	Thread tension releasing pin $\phi$ 2x28.4	1
A40		MF10A0555	チョウシガラ	Thread tension discs	2
A41		MH40A0556	チョウシガラササエ	Thread tension releasing discs	1
A42		MF11D0245	エンスイハネ	Thread tension spring $\phi$ 1.0	1
A43		MT60A0802	マワリドメ	Thumb net revolution stopper	1
A44		M91610046	ツマミネジ	Thumb nut	1
A45		MF70A1180	イトアンナイ	Thread guide	1
A46		M90943003	マルヒラネジ	Screw 9/64(40)x6	1
A901		MF80E0470	スベリイタクミタテ	Slide plate complete	1
A902		MF00E0550	イトチョウセツキクミタテ	Pre-tension assy.	1
A903		MN36E0210	チョウセツキクミタテ	Thread tension regulator assy.	1

**B 縫機構 (I)**  
**SEWING MECHANISM (I)**

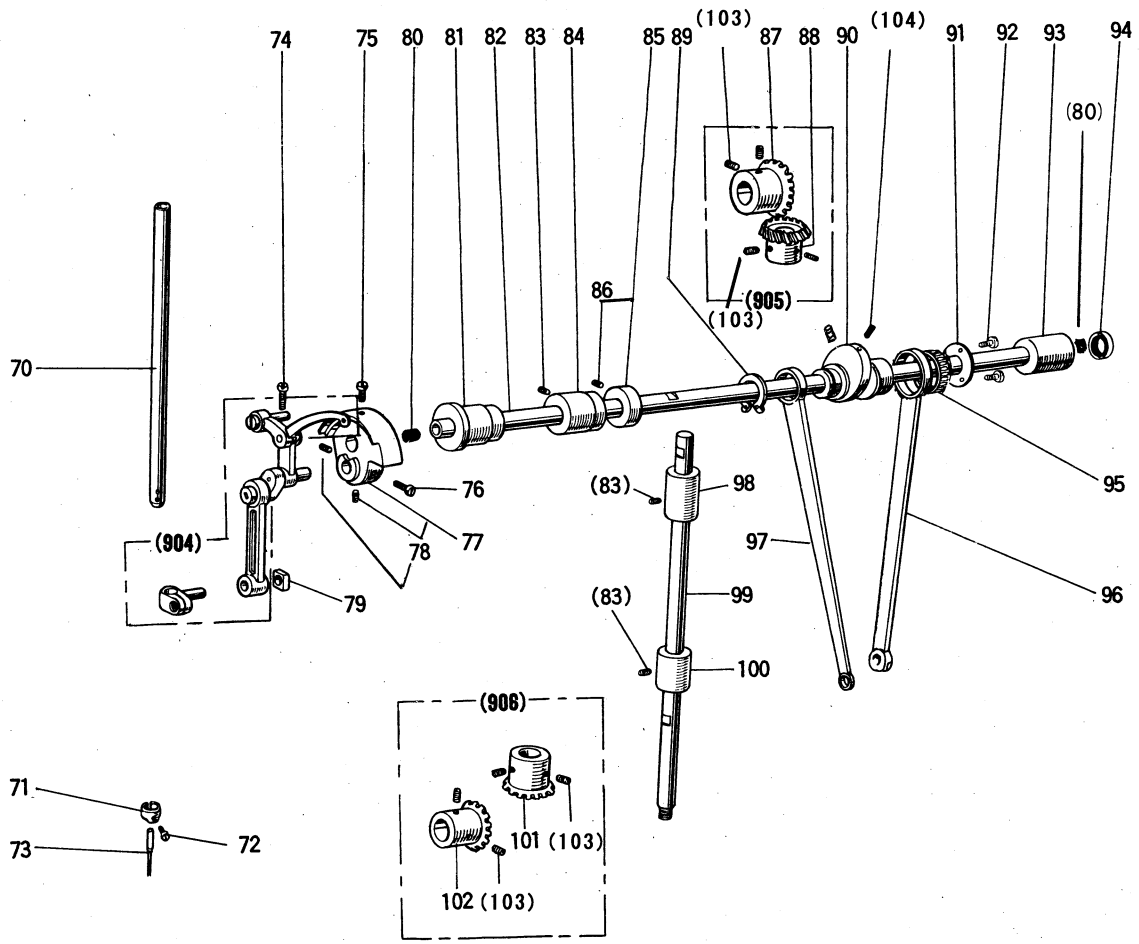

B 縫機構

SEWING MECHANISM (I)

Fig. 変更	部品コード			使用数	
No.	Mod.	Parts.No.	Description	Description	Amt. Req.
B70		MF05A0660	ハリ棒 ウクミタテ	Needle bar	1
B70		MN36A0660	ハリ棒 ウクミタテ	Needle bar (for U.S. CE)	1
B71		MN35A0181	イトアンナイ	Thread guide	1
B72		M90815002	ヒラネジ	Screw 1/8(44)x4.5	1
B73		MF70A0128	ミシンハリ DBX1-2 #14	Needle set DBX1-2 #14	1
B73		MV01A0128	ミシンハリ DPX5 #14	Needle set DPX5 #14 (for U.S. CE)	1
B74		M91113002	ヒラネジ	Screw 11/64(40)x15	1
B75		M91802006	ヒラネジ 棒 ウサキ	Screw 9/32(28)x14	1
B76		M91801002	ヒラネジ	Set screw 9/32(28)x13	1
B77		MF90A0383	クランクウクミタテ	Crank with screw	1
B78		M91606001	トメネジ	Set screw 1/4(40)x6	2
B79		MF10A0325	かくコマ	Square block	1
B80		M90740080	ゴムセキ	Rubber plug $\phi$ 7.4	2
B81		MF80A0232	ウワジ クメタルヒタリ	Upper shaft bushing (left)	1
B82		MN36E0230	ウワジ クミタテ(ゴムセキ)	Upper shaft	1
B83		M91513001	トメネジ	Set screw 15/64(28)x10	3
B84		MF05A0234	ウワジ クメタルナカ	Bushing for arm shaft(middle)	1
B85		MF80A0352	カラクミタテ	Thrust collar assy.	1
B86		M91602001	トメネジ	Set screw 1/4(40)x4	2
B87		MF40A0331	ウワジ クカサハグ ルマ	Bevel gear for arm shaft	1
B88		MF40A0333	タテジ クカサハグ ルマウエ	Bevel gear for vertical shaft(upper)	1
B89		M90320065	C ガ タトメウ ジクヨウ 20	C-type stop ling 20	1
B90		MN36A0492	ヘンシンリン	Feed drive eccentric cam	1
B91		M93008050	ザガネ	Thrust collar $\phi$ 36	1
B92		M90902011	マルサラネジ	Screw 3/16(28)x13	3
B93		MF01A0233	ウワジ クメタルミキ	Bushing for arm shaft(right)	1
B94		M91472086	オイルシール 91A-1192-R	Oil seal for arm shaft(right)	1
B95		MN35A0628	ベアリング	Needle bearing	1
B96		MF00A1386	レンセツカン	Connecting rod for feed cam	1
B97		MF70A0384	レンセツカン	Connecting rod for feed lifting cam	1
B98		MF00A0521	タテジ クメタルウエ	Bushing for vertical shaft(upper)	1
B99		MF10A0520	タテジ ク	Vertical shaft	1
B100		MF70A0522	タテジ クメタルシタ	Bushing for vertical shaft(lower)	1
B101		MF10A0334	タテジ クカサハグ ルマシタ	Bevel gear for vertical shaft(lower)	1
B102		MF10A0332	シタジ クカサハグ ルマ	Bevel gear for hook shaft	1
B103		M91610001	トメネジ	Set screw 1/4(40)x7	8
B104		M91516001	トメネジ	Set screw 15/64(28)x14	2
B904		MF05E0580	テンビンハリクミタテ	Thread take-up lever assy.	1
B905		MF01E0331	カサハグ ルマクミタテ	Bevel gear for arm shaft	1
B906		MF01E0332	カサハグ ルマクミタテ	Bevel gear for arm shaft	1

**㉞ 縫機構(Ⅱ)**  
**SEWING MECHANISM (Ⅱ)**

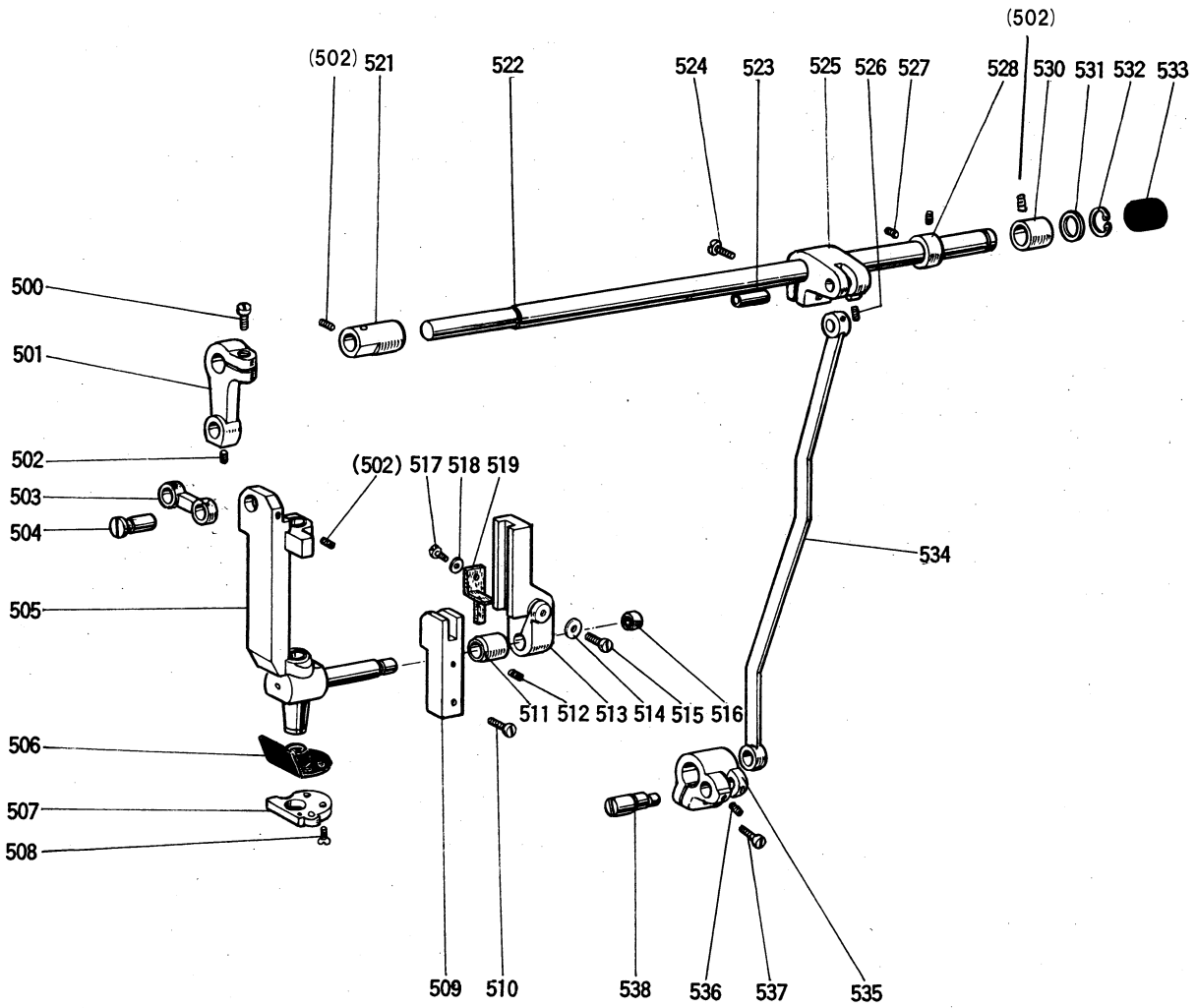

## C 縫機構 (II)

## SEWING MECHANISM (II)

Fig. No.	変更 No.	部品コード Parts.No.	Description	Description	使用数 Amt. Req.
C500		M91203002	ヒラネジ	Screw 3/16 (28) X15	1
C501		MN35A0273	ハリオクリウテ	lever	1
C502		M91108001	トメネジ	Screw 11/64 (40) X5.5	4
C503		MN35A0910	リンク	Link	1
C504		MN35A0530	ツバ ツキジク	Set pin	2
C505		MN35E0666	ハリボ ウサエジ クミタテ	Needle bar supportor assy.	1
C505		MN36E0666	ハリボ ウサエジ クミタテ	Needle bar supportor assy. (for U. S. CE)	1
C506		MN35A1691	ハ ツキン	Gasket	1
C507		MN35A0257	オサエイタ	Fitting plate	1
C508		M90904011	マルサラネジ	Screw 9/64 (40) X6.5	3
C509		MN35A0667	ハリボ ウサエカ イト	Guide bracket	1
C510		M91106004	プ ラマイネジ	Screw 11/64 (40) X8	2
C511		MN35A0833	ハリボ ウサエジ クメタル	Bushing	1
C512		M91106001	トメネジ	Set screw 11/64 (40) X4	1
C513		MN35A0662	ハリカ イト ウテ	Needle bar connecting link guide	1
C514		M90552050	コサ ガ ネ 5	Washer 5	1
C515		M91203002	ヒラネジ	Screw 3/16 (28) X15	1
C516		MN35A1628	ニード ルベ アリソク	Needle bearing	1
C517		M90806002	ヒラネジ	Screw 1/8 (44) X6	1
C518		M90311050	コサ ガ ネ M3	Washer 3	1
C519		MN35A0740	フェルト	Felt	1
C521		MN35A0285	ハリオクリジ クメタルヒタリ	Bushing	1
C522		MN35A0284	ハリオクリジ ク	Needle feed rock shaft	1
C523		MN35A0454	ジク	Pin	1
C524		M91204003	マルヒラネジ	Screw 3/16 (28) X12	1
C525		MN35A1273	ハリオクリウテ ミキ	Lever	1
C526		M91108001	トメネジ	Set screw 11/64 (40) X5.5	1
C527		M91601001	トメネジ	Set screw 1/4 (40) X2.7	2
C528		MT60A0352	カラー	Collar	1
C530		MN35A1285	ハリオクリジ クメタルミキ	Bushing	1
C531		M91402050	ザ ガ ネ	Washer	1
C532		M90312065	カ タトメワ 12	Retaining ring-C12	1
C533		M92005080	セン	Rubber plug	1
C534		MN35A1910	リンク	Link	1
C535		MN35A0392	ハリオクリク ウテ	Needle feed driving lever	1
C536		M91108001	トメネジ	Screw 11/64 (40) X5.5	1
C537		M91203002	ヒラネジ	Screw 3/16 (28) X15	1
C538		MN35A0761	ヘンソソジク	Eccentric pin	1



㊦ 縫機構(Ⅱ)および水平送り軸, 上下送り軸機構  
 SEWING MECHANISM (Ⅱ) FEED ROCK SHAFT, FEED LIFTING  
 ROCK SHAFT MECHANISM

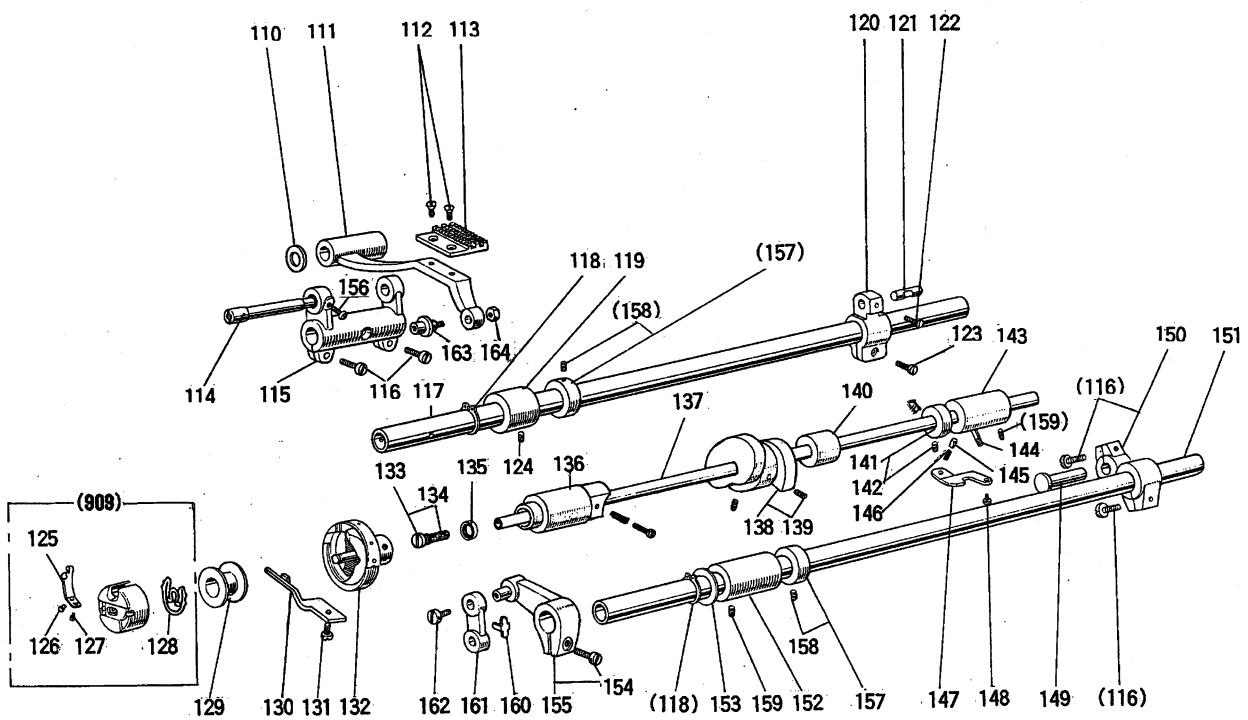

D 縫い機構 (II) および水平送り軸、上下送り軸機構

SEWING MECHANISM (II) FEED ROCK SHAFT, FEED LIFTING  
ROCK SHAFT MECHANISM

Fig.	変更	部品コード	部品名	Description	使用数
No.	Mod.	Parts.No.			Amt. Req.
D110		M90619050	サガネ	Washer φ10	1
D111		MN36E0281	オクリタ イミタ	Feed bar assy.	1
D112		M90806002	ヒラネジ	Screw 1/8(44)x6	2
D113		MN35A0104	オクリ	Feed dog	1
D114		MF90A0283	ヘンジンク	Shaft for feed bar (eccentric)	1
D115		MF90A0278	スィエイオクリウテ ヒタリ	Feed rock shaft crank (left)	1
D116		M91204003	マルヒラネジ	Screw 3/16(28)x12	4
D117		MF70A0491	スィエイオクリンク	Feed rock shaft	1
D118		M90315065	カ タトメ シクヨウ 15	Retaining ring-C type 15	2
D119		MG75A0285	オクリンクメタル	Bushing for feed rock shaft (left)	1
D120		MF00A0279	スィエイオクリウテ ミキ	Feed rock shaft crank (right)P=17.5	1
D121		MF00A0454	ジク	Feed rock shaft crank pin	1
D122		M91521002	ヒラネジ	Screw 11/64(40)x7	1
D123		M91113002	ヒラネジ	Screw 11/64(40)x15	1
D124		M91506001	トメネジ	Set screw 15/64(28)x7	1
D125		MF01A0557	イトヨウシハネ	Bobbin thread tension spring	1
D126		M97085030	イトヨウシネジ	Tension spring screw 3/32(100)x1.6	1
D127		M97087030	イトヨウシハネトメネジ	Tension regulating screw 1/16(80)x1.2	1
D128		MF01A1245	クウテンホウシハネ	Bobbin tension spring	1
D129		MF00A0123	ホビン	Bobbin	1
D130		MF10A0229	ウチガマトメ	Rotating hook positioner	1
D131		M91118002	ヒラネジ	Screw 11/64(40)x10	1
D132		MF13A0120	カマクミタ HSL-BTR	Rotary hook assy.	1
D133		M91259030	トクシユネジ フェルトクミ	Screw complete	1
D134		MF05A0740	フィルタ	Oil felt	1
D135		M90800086	オイルシール G8X12X3	Oil seal	1
D136		MF00A0451	シタジクメタルヒタリ	Lower shaft bushing (left)	1
D137		MF00A0450	シタジク	Lower shaft	1
D138		MF01E0350	イトキリカムミタ	Thread trimmer cam	1
D139		M91602020	ロツカクアナツキトメネジ	Soket set screw 1/4(40)x10	2
D140		MF00A0453	シタジクメタルナカ	Lower shaft bushing (middle)	1
D141		MF01E0352	カラクミタ	Thrust collar	1
D142		M91106001	トメネジ	Set screw 11/64(40)x3.75	2
D143		MF00A0452	シタジクメタルミキ	Bushing for hook shaft (right)	1
D144		MF80A0688	パイプ	Pipe	1
D145		MF00A0753	プランジャー	Plunger	1
D146		MF00A0572	ツルマキハネ	Spring	1
D147		MF80A0154	アンナイイタ	Guide plate	1
D148		M91515002	ヒラネジ	Screw 15/64(28)x10	1
D149		M90904060	ツバ ツキシク	Connecting rod stud	1
D150		MF80A0277	シヨウケオクリウテ ミキ	Feed lifting rock shaft crank (right)	1
D151		MF30A0460	シヨウケオクリンク	Feed lifting rock shaft	1
D152		MF70A0286	オクリンクメタル	Bushing for feed lifting rock shaft (left)	1
D153		M91502050	サガネ	Washer φ20.5	1
D154		M91112002	ヒラネジ	Screw 11/64(40)x12	1
D155		MN35E0276	シヨウケオクリウテ ヒタリクミタ	Feed lifting rock shaft crank (left)	1
D156		M91106004	プ ラマイネジ	Screw 11/64(40)x8	1
D157		MF80A0352	カラクミタ	Thrust collar assy.	2
D158		M91602001	トメネジ	Set screw 1/4(40)x4	4
D159		M91513001	トメネジ	Set screw 15/64(28)x9.5	2
D160		MF05A0780	ホルダ	holder	1
D161		MF05A0910	リンク	Link	1
D162		M90942003	マルヒラネジ	Screw 9/64(40)x6.5	2
D163		M91257030	トクシユネジ	Stud screw 3/16(32)x5	1
D164		M91252045	ナット	Nut 3/16(32)	1
D909		MN35A0125	ホビンケース	Bobbin case assy.	1

目 送り調節機構

STITCH LENGTH REGULATOR MECHANISM

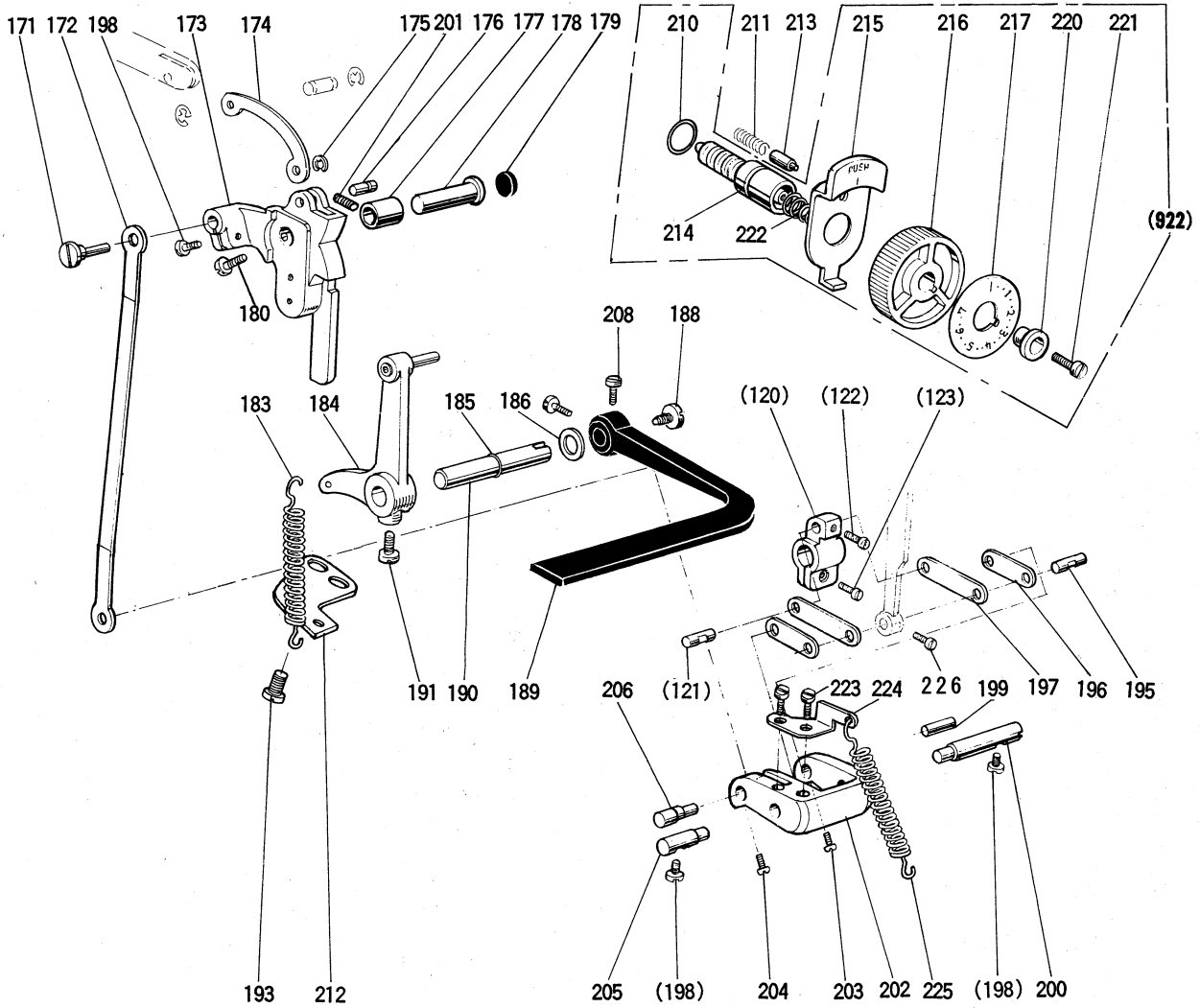

## E 送り調節機構

## STITCH LENGTH REGULATOR MECHANISM

Fig. 変更 No.	部品コード Mod. Parts.No.	部品名	Description	使用数 Amt. Req.
E171	MN35A1530	ダンツキジク	Connecting rod stud	1
E172	MF00A6910	リンク	Feed regulating link	1
E173	MF00A1152	オクリチヨウセツカム	Feed regulator	1
E174	MF00A7910	リンク	Link	1
E175	M90504065	Eタイプ 4	E-type stop ring 4	1
E176	M90519060	ピン	Pin	1
E177	MF70A0750	ブッシュ	Bushing for feed regulator	1
E178	M90904063	ダンツキジク	Set pin	1
E179	M92004080	セン	Rubber plug $\phi 20$	1
E180	M91516002	ヒラネジ	Screw 15/64(28)x8.5	1
E183	MF00A5572	ツルマキバネ	Coil spring	1
E184	MF00E1635	ヌイメカゲンウテクミダテ	Reverse lever shaft	1
E185	M90600085	Oリング 1AP6	O-ring ( $\phi 6$ ) (1AP6)	1
E186	M95003053	バネサガネ	Spring washer	1
E188	M91207003	マルヒラネジ	Screw 3/16(28)X6.5	1
E189	MF01A0632	ヌイメカゲンレバ	Reverse lever	1
E190	MF00A0633	ヌイメカゲンジク	Reverse lever shaft	1
E191	M91501007	マルヒラネジ ホウサキ	Screw 15/64(28)x14.5	1
E193	M91505002	ヒラネジ	Screw 15/64(28)X13.5	1
E195	MF00A1454	ジク	Link stud	1
E196	MF00A2910	リンク	Link	2
E197	MF00A3910	リンク	Link	2
E198	M91112002	ヒラネジ	Screw 11/64(40)x12	3
E199	MF00A2454	ジク	Link stud	1
E200	MN35A2530	ダンツキジク	Feed regulator shaft	1
E201	M91513001	トメネジ	Set screw 15/64(28)X9.5	1
E202	MF00A0289	オクリチヨウセツウテ	Stitch length adjusting crank	1
E203	M90905002	ヒラネジ	Screw 9/64(40)x8.5	1
E204	M90903002	ヒラネジ	Screw 9/64(40)x6.5	1
E205	MN35A3530	ダンツキジク	Feed regulator shaft	1
E206	MN35A4530	ダンツキジク	Link stud	1
E208	M91515002	ヒラネジ	Screw 15/64(28)X10	2
E210	M91000085	Oリング 1AP10A	O-ring ( $\phi 10$ ) (1AP10A)	1
E211	MF05A0572	ツルマキバネ	Spring	1
E212	MF00A3708	カケガネ	Spring holder	1
E213	MF00A0852	ピン	Stopper pin	1
E214	MF85A0640	オクリチヨウセツネジ	Screw bar	1
E215	MF00A0950	レバ	Releasing lever	1
E216	MF01A0631	ダイヤル	Dial for stitch length regulator	1
E217	MF01A0841	メモリイタ	Stitch length indicating plate	1
E220	MF00A0257	オサエガネ	Bushing	1
E221	M91215002	ヒラネジ	Screw 3/16(28)x12	1
E222	MF02A0245	エンスイバネ	Coil spring	1
E223	M90921002	ヒラネジ	Screw 9/64(40)X8	2
E224	MF00A4708	カケガネ	Spring holder	1
E225	MF00A6572	ツルマキバネ	Coil spring	1
E226	M91521002	ヒラネジ	Screw 11/64(40)x7	1
E922	MF01E0640	オクリチヨウセツネジクミ	Screw bar assy.	1

F 押え機構  
 PRESSER FOOT MECHANISM

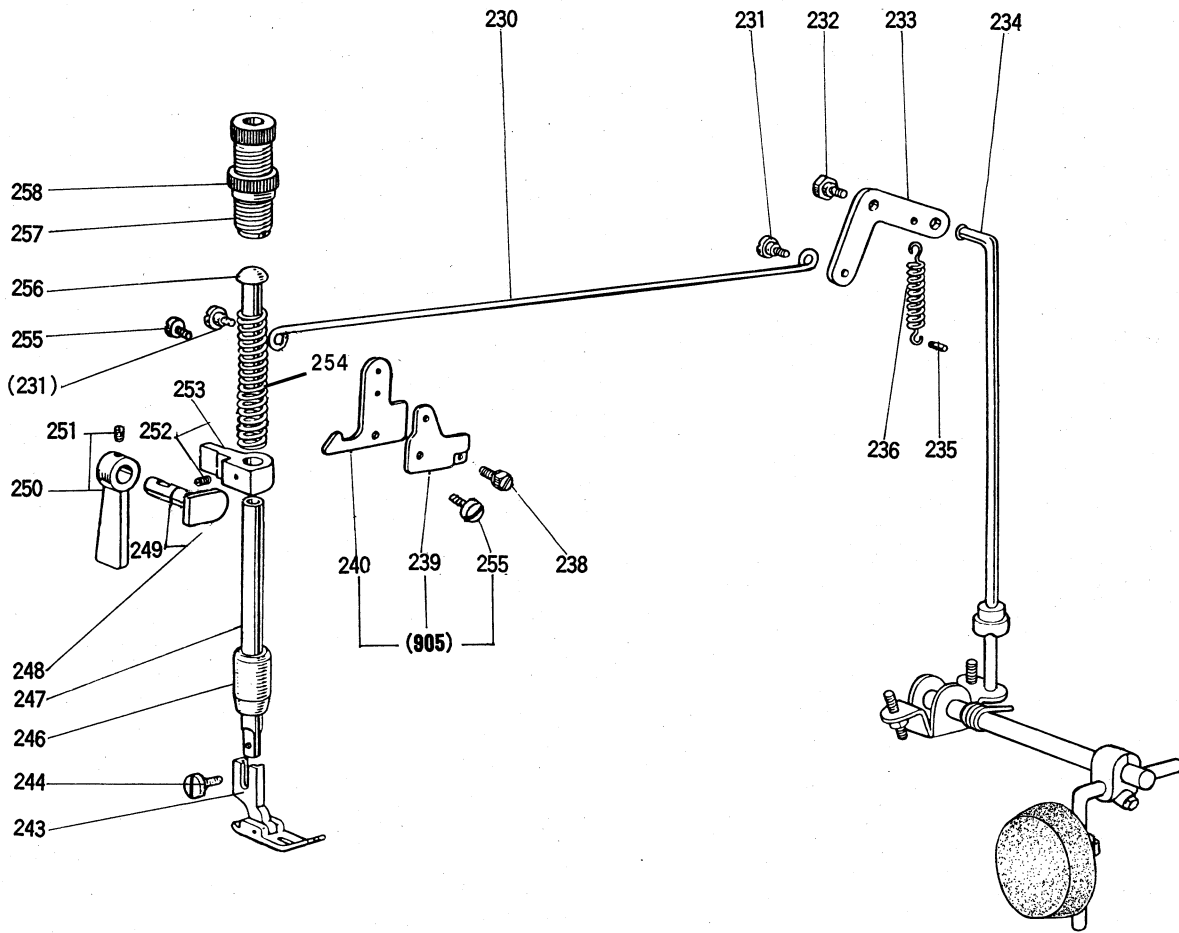

## F 押え機構

## PRESSER FOOT MECHANISM

Fig. 変更 No. Mod.	部品コード Parts.No.	部品名	Description	使用数 Amt. Req.
F230	MF70A0738	ヒキボウ	Knee liffter rod	1
F231	M91219015	ヒラネジ ダンツキ	Hinged screw 3/16(28)x7	2
F232	M91503031	ボルト	Bolt for knee liffter lever	1
F233	MF30A0252	オサエアゲレバ-ミキ	Knee liffter lever(right)	1
F234	MF70A0511	ソウサボウ	Knee liffter connecting rod	1
F235	M95003067	ミゾ ツキピン BX ガタ 5X24	Pin(BX-Type) (φ5x24)	1
F236	MF30A0572	ツルマキハネ	Spring for knee liffter lever	1
F238	M91504031	ボルト	Bolt 15/64(28)x13.5	1
F239	MF70A0350	イトルメカム	Tension releasing cam	1
F240	MF00A1950	オサエアゲレバ-ヒタリ	Knee liffter lever(left)	1
F243	MN36E0105	オサエクミタテ(フィンガード)	Presser foot(Finger guard)	1
F244	M90939002	ヒラネジ	Screw 9/64(40)x11	1
F246	MF00A0267	オサエボウメタル	Bushing for presser bar	1
F247	MF11D0262	オサエボウ	Presser bar	1
F248	MF00A0253	オサエアゲカムクミタテ	Presser bar lifting cam	1
F249	M90400085	O リング 1AP4	O-ring(1AP4)	1
F250	MF01E0252	オサエアゲクミタテ	Presser bar liffter	1
F251	M91108001	トメネジ	Set screw 11/64(40)x5.5	1
F252	M91506001	トメネジ	Set screw 15/64(28)x7	1
F253	MN35A0265	オサエボウウタキクミ	Presser bar guide bracket	1
F254	MF12B0259	ツルマキハネ	Presser spring	1
F255	M91131002	ヒラネジ	Screw 11/64(40)x6.5	1
F256	MF20A0703	アンナイボウ	Presser bar guide	1
F257	M93220035	ツマミネジ	Thumb screw 1/2(28)x63	1
F258	M93202047	トクシユナツト	Nut	1
F905	MF00E0252	オサエアゲレバ-ヒタリクミ	Knee liffter lever (left)	1

G 糸切り機構  
 KNIFE ACTUATING MECHANISM

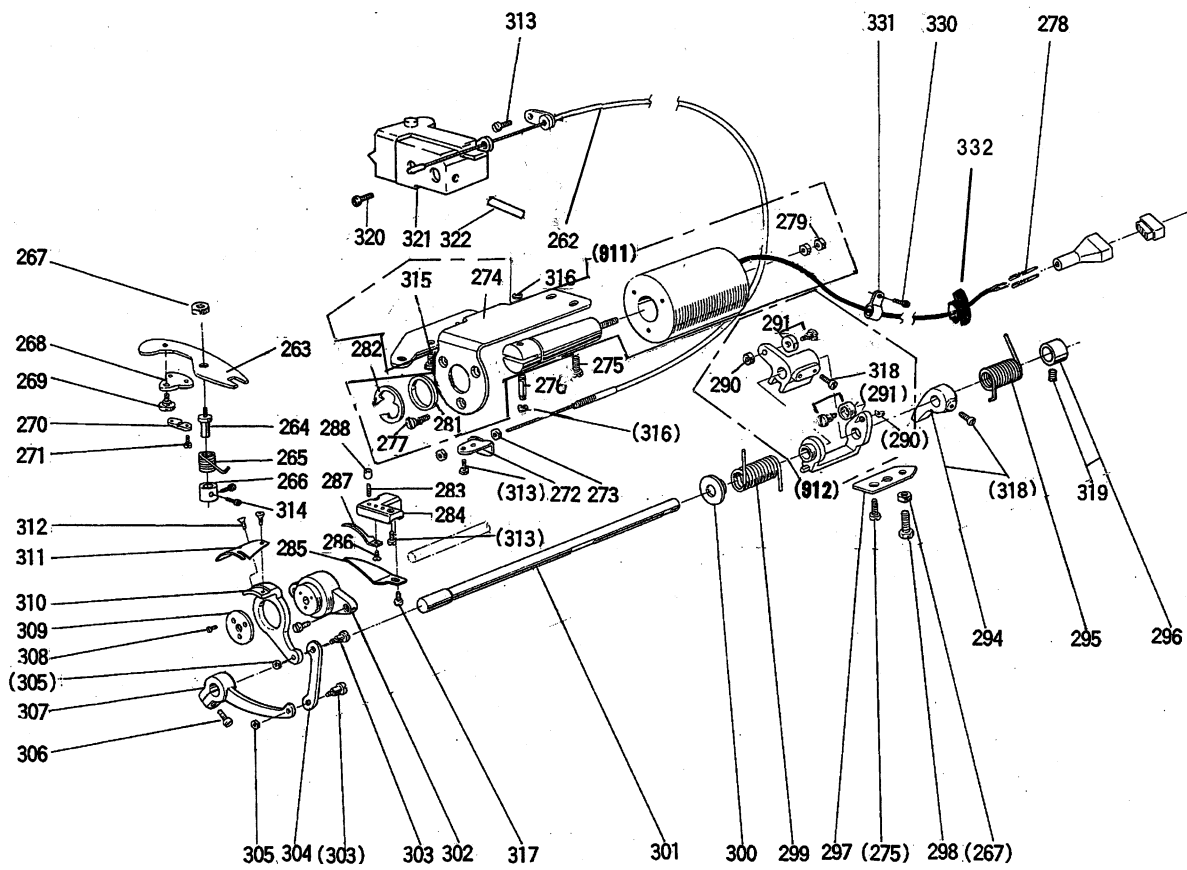

## G 系切り機構

## KNIFE ACTUATING MECHANISM

Fig. 変更 No.	部品コード Mod. Parts.No.	部品名	Description	使用数 Amt. Req.
G262	MF01E0746	フレキシブルワイヤクミタテ	Flexible wire assy.	1
G263	MF00A1391	クドウイタ	Thread trimmer driving lever	1
G264	M97082030	トクシュネジ	Stud screw 15/64(28)x7.5	1
G265	MF00A1729	ヒネリハネ	Trimming lever spring	1
G266	MF00A1352	カラー	Spring support collar	1
G267	M91502045	ナット	Nut 15/64(28)	2
G268	MF90A0361	カケガネ	Flexible wire holder	1
G269	M91127015	ヒラネジダツキ	Stud screw 11/64(40)x5	1
G270	MF36A0750	ブッシュ	Flexible wire presser	1
G271	M90802002	ヒラネジ	Screw 1/8(44)x7	2
G272	MF00A0780	ホルダ	Holder	1
G273	M91373045	ナット M5	Nut M5x4T	2
G274	MF00A1509	ソレノイドトリツケイタ	Solenoid mounting bracket	1
G275	M91510002	ヒラネジ	Screw 15/64(28)x12	4
G276	M90516063	ピン	Link stud	1
G277	M94008037	Pサラネジ M4x6	Screw M4x6	3
G278	M93003099	ターミナルピン	Terminal 1380TL	2
G279	M92074045	ナット M5	Nut M5	2
G281	MF01A0379	クッション	Cushion	1
G282	M90703065	Eタイプメウ 12	E-type stop ring 12	1
G283	M90913001	トメネジ	Set screw 9/64(40)x8.5	1
G284	MF00A1603	トリツケイタ	Bracket for fixed blade	1
G285	MF00A0180	イトアンナイ	Thread finger	1
G286	M90907010	サラネジ	Screw 9/64(40)x4.1	1
G287	MN35A0838	コテイメス	Fixed blade	1
G288	M91110045	ナット	Nut 9/64(40)	1
G290	M91201045	ナット	Nut 3/16(28)	2
G291	MF01E0411	コロ、コロジククミタテ	Cam follower, Shoulder screw assy.	2
G294	MF01E0477	ストツパクミタテ	Stopper lever assy.	1
G295	MF00A0729	ヒネリハネ	Coil spring	1
G296	MF00A0352	カラークミタテ	Thrust collar assy.	1
G297	MF00A1477	ストツパイタ	Lever stopper plate	1
G298	M91512022	ボルト	Bolt 15/64(28)x20	1
G299	MF00A9572	ツルマキハネ	Coil spring	1
G300	MF00A0750	ブッシュ	Bushing	1
G301	MF00A5454	メスヨウトウジク	Knife driving shaft	1
G302	MF00A1527	ダイザ	Knife holding bracket saddle	1
G303	M91111015	ヒラネジダツキ	Stud screw 11/64(40)x6.2	2
G304	MF00A8910	リンク	Link	1
G305	M91107045	ナット	Nut 11/64(40)	2
G306	M91117002	マルヒラネジ	Screw 11/64(40)x13	1
G307	MF00A1392	クドウウテ	Knife driving crank	1
G308	M90803010	サラネジ	Screw 1/8(44)x6	3
G309	M94006052	ザガネ	Thrust collar φ28	1
G310	MF00A0836	メスタイタリ	Knife base (left)	1
G311	MF00A0834	メスタリ (A)	Movable knife (left) (A)	1
G312	M91151010	サラネジ	Screw 11/64(40)x7	2
G313	M91106004	プライマイネジ	Screw 11/64(40)x8	6
G314	M90903002	ヒラネジ	Screw 9/64(40)x6.5	2
G315	M91118002	ヒラネジ	Screw 11/64(40)x10	1
G316	M90504065	Eタイプメウ 4	E-type stop ring 4	2
G317	M90921002	ヒラネジ	Screw 9/64(40)x8	1
G318	M91516002	ヒラネジ	Screw 15/64(28)x8.5	3
G319	M91602001	トメネジ	Set screw 1/4(40)x4	1
G320	M91113002	ヒラネジ	Screw 11/64(40)x15	2
G321	MN35E0173	イトルメタイクミタテ	Thread tension releasing bracket assy.	1
G322	M90520060	イトルメピン	Thread tension releasing pin	1
G330	M91109004	ザガネツキプライマイネジ	Screw 11/64(40)x8	1
G331	M94003099	ナイロンクリップ AB-3N	Cord holder	1
G332	M91004080	ゴムブッシュ	Rubber plug φ10	1
G911	MF06E3519	ソレノイドトリツケイタクミタテ	Thread trimming solenoid	1
G912	MF01E0351	カムツインユウテクミタテ	Cam follower crank assy.	1



**㊦ タッチバック機構および検出器機構**  
**TOUCH BACK MECHANISM & DETECTOR MECHANISM**

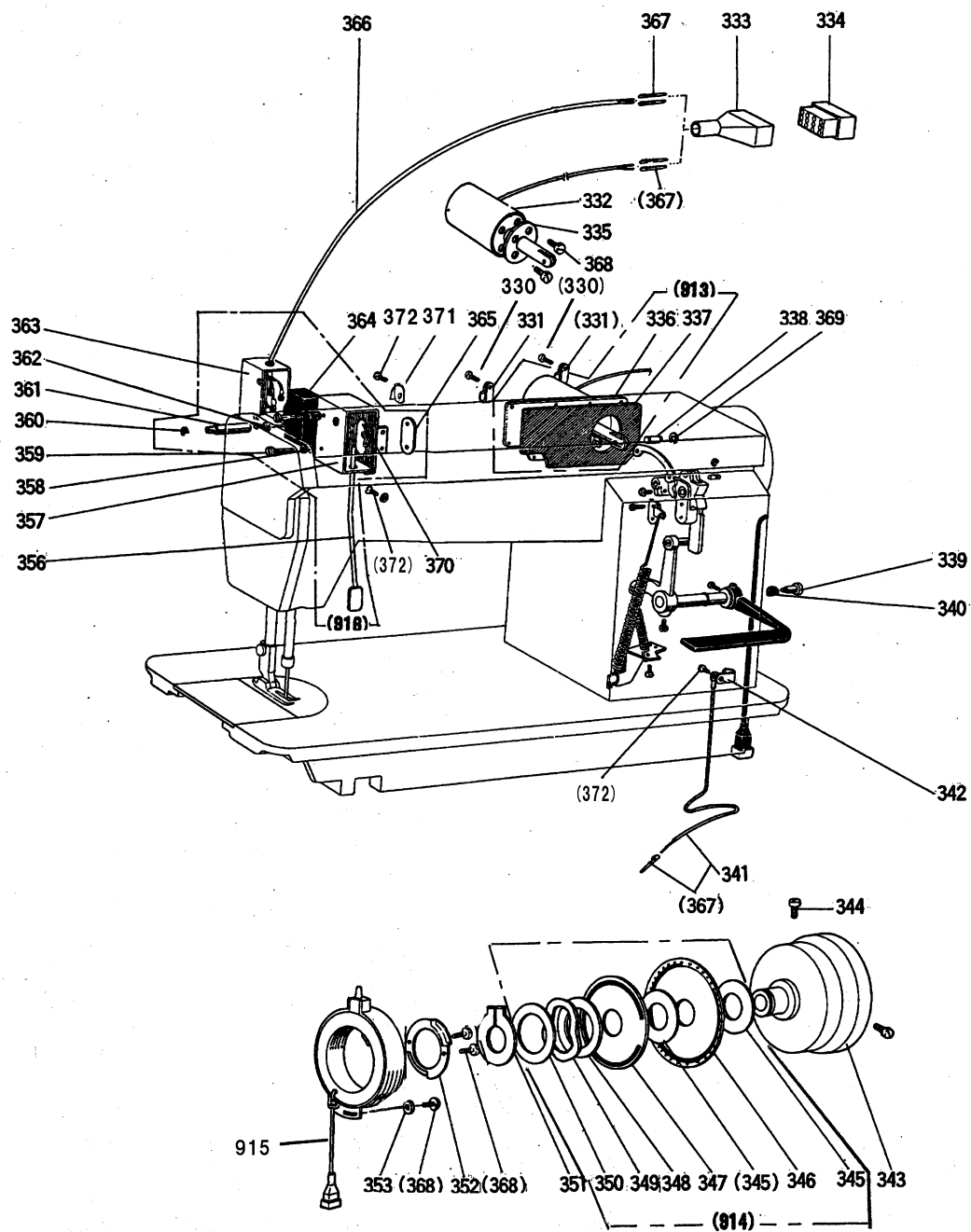

H タッチバック機構および検出器機構

TOUCH BACK MECHANISM & DETECTOR MECHANISM

Fig. 変更 部品コード				使用数
No.	Mod.	Parts.No.	部品名	Amt. Req.
H330		M91111004	ブ ラマイネジ	2
H331		MN60A0620	ナイロンクリップ AB-5N	2
H332		MG34E0519	ソレノイド	1
H333		MG68A0366	コネクタキャップ	1
H334		M91018099	コネクタ 1360-P	1
H335		MF01A0691	ガスケット	1
H336		MF01A0880	ヨコブタ	1
H337		MF00A1691	ガスケット	1
H338		M90516063	ピン	1
H339		M91515015	ヒラネジ タンツキ	1
H340		MN36A0417	ゴムワ	1
H341		M97003095	アースセンキタテ	1
H342		MB60A1620	ナイロンクリップ AB-8N	1
H343		MF01A0682	プ リー	1
H344		M91502002	ヒラネジ	2
H345		MF01A0476	スペーサ A	2
H346		MF01A0694	ハンシャパン B12(シタ)	1
H347		MF01A1694	ハンシャパン B21(ウエ)	1
H348		MF01A1476	スペーサ B	1
H349		MF01A0259	ハンシャパンオサエ スプ リング	1
H350		M93001050	ザ ガ ネ 30	1
H351		M90330065	カ タトメワ 30	1
H352		MF01A0257	オサエイタ	1
H353		M93002050	ザ ガ ネ	1
H356		MN35A0950	レバークミタテ	1
H357		MN36A0339	タッチスイッチカバー	1
H358		M90450050	ミガキザガネ	2
H359		M91276004	SW-PWツキ ブ ラマイネジ	2
H360		M90505065	エカ タトメワ 5	1
H361		MF40A1530	タンツキシク	1
H362		M91117002	マルヒラネジ	1
H363		MF40A3339	タンシホゴ カバ AA-8000	1
H364		M90204099	スイッチ AM13065	1
H365		MF40A3601	トリツケイタ	1
H366		M97104099	コードクミタテ	1
H367		M93003099	ピン 1380TL	5
H368		M91106004	ブ ラマイネジ	7
H369		M90504065	エカ タトメワ 4	2
H370		MF40A0729	ヒネリハネ	1
H371		MN50A0780	ホルダ	1
H372		M91109004	ザ ガ ネツキブ ラマイネジ	3
H913		MN36E0519	ヨコブ タクミタテ	1
H914		MN36E0694	エンパンセット	1
H915		ME20A0406	センサー (XC-K2000)	1
H916		MN36E0534	タッチスイッチクミタテ	1

J ワイパー機構  
WIPER MECHANISM

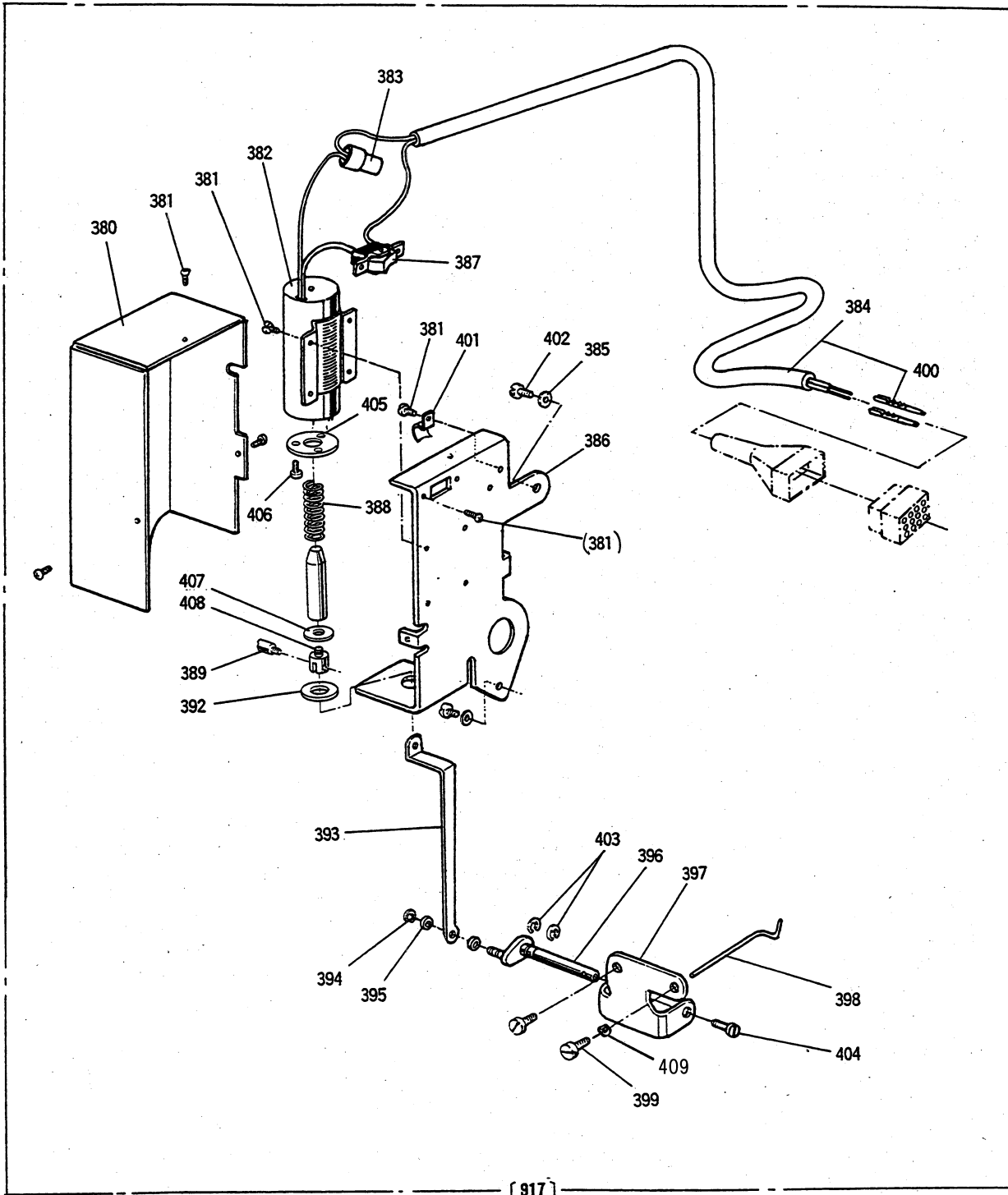

J ワイパー機構

WIPER MECHANISM

Fig. 変更		部品コード	部品名	Description	使用数
No.	Mod.	Parts.No.			Amt. Req.
J380		MF01A0339	カバー	Solenoid cover for wiper mech.	1
J381		M90308037	SW-PWツキナベネジ M3X6	Screw-SW-PW M3x6	10
J382		MF06A1519	チュウブソレノイド	Wiper solenoid	1
J383		M91019099	JST 1-SD	Connecting 1-SD	1
J384		M97061095	コードクミタテ	Cord assy.	1
J385		M90604050	ワッシャ 6	Washer 6	2
J386		MF01A2601	ソレノイドトリツケイタ	Solenoid bracket	1
J387		MF40E2484	ハドウスイッチ DS-035	Thread wiper switch	1
J388		MF06A0572	コイルバネ	Spring	1
J389		M90910033	ピンネジ	Plunger pin 9/64(40)x4	1
J392		MF00A0417	ゴムワ	Rubber cushion	1
J393		MF00A5910	リンク	Thread wiper connecting rod	1
J394		M90513065	Eタイプメ7 2.5	E-type stop ring 2.5	1
J395		M90454050	BS-ワッシャ 4	Washer 4	2
J396		MF01A0454	ワイパーシャフト	Wiper shaft	1
J397		MN35A0982	ワイパートリツケイタ	Thread wiper bracket	1
J398		MN35A0980	ワイパー	Thread wiper	1
J399		M91106003	マルチネジ	Screw 11/64(40)x20	2
J400		M93003099	ターミナルピン	Terminal 1380TL	2
J401		M94002099	ナイロンクリップ AB-2N	Cord holder	1
J402		M91515002	ヒラネジ	Screw 15/64(28)x10	2
J403		M90504065	Eタイプメワ 4	E-type stop ring 4	2
J404		M90806002	ヒラネジ	Screw 1/8(44)x6	1
J405		M74008052	ワッシャ	Spring guide	1
J406		M90309037	SW-PWツキナベネジ M3X5	Screw M3x5	3
J407		M70828050	ワッシャ	Retaine washer	1
J408		M78003033	ピンネジ	Stud screw	1
J409		M90421050	ワッシャ	Washer 4	1
J917		MN36E0984	ワイパーソウチクミタテ	Wiper devics assy.	1

**K** 給油機構  
**OIL LUBRICATION MECHANISM**

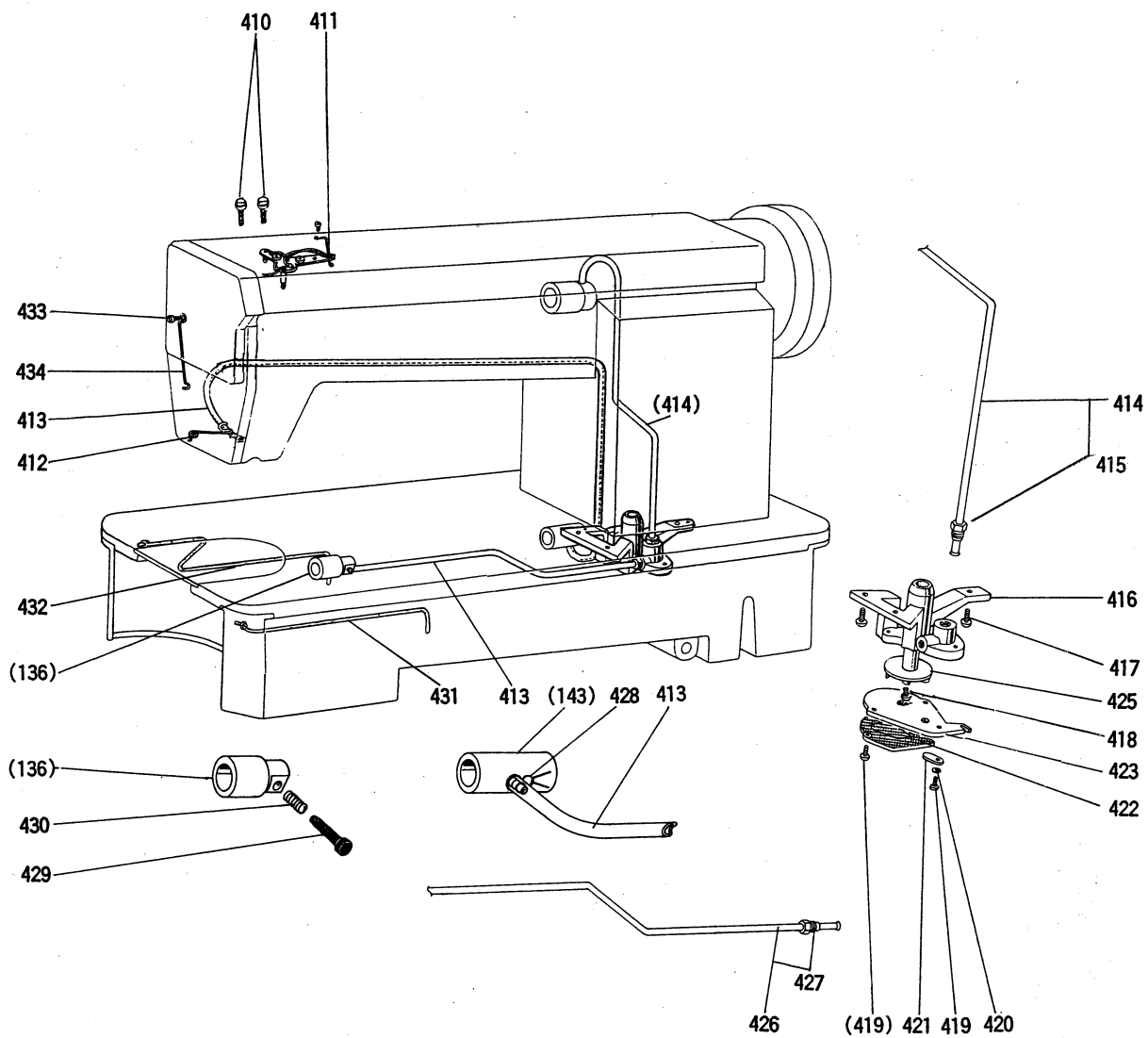

K 給油機構

OIL LUBRICATION MECHANISM

Fig. 変更 No. Mod.	部品コード Parts.No.	部品名	Description	使用数 Amt. Req.
K410	M90939002	ヒラネジ	Screw 9/64 (40) x11	2
K411	MN35A0601	トリツケイタヒモクミタテ	Oil wick fitting plate assy.	1
K412	MN35A0780	ホルダ	Holder	1
K413	MN36E0731	カンユパイクミタテ	Oil return pipe assy.	1
K414	MF80A1688	パイウエクミタテ	Upper shaft oil tube assy.	1
K415	MF40A1750	ブツシュ	Oil tube lock bushing 1/2 (28)	1
K416	MF80A0783	ポンプケース	Oil pump	1
K417	M91103004	ブラマインジ	Screw 11/64 (40) x13	3
K418	M90810002	ヒラネジ	Screw 1/8 (44) x6.5	1
K419	M90801004	ブラマインジ	Screw 1/8 (44) x13	3
K420	M90304053	ハネサガネ 3.5	Spring washer 3.5	1
K421	MF10A1742	フタ	Oil adjusting plate	1
K422	MF10E0337	アミクミタテ	Oil pump screen	1
K423	MF00A2601	トリツケイタ	Oil pump impeller cover	1
K425	MF10A0685	ハネクマ	Oil pump impeller	1
K426	MF00E0142	パイシタクミタテ	Oil pipe for hook assy.	1
K427	M92201047	ブツシュ	Oil tube lock bushing 11/32 (28)	1
K428	MF01A0378	タルマクリツフ 6	Holder for oil braid 6	1
K429	M97084030	トクシユネジ	Oil adjusting screw	1
K430	MF80A1572	ツルマキハネ	Spring	1
K431	MN70E0148	ヒモ	Oil wick	1
K432	MF95A0148	ヒモ	Oil wick	1
K433	M91108002	ヒラネジ	Screw 11/64 (40) x7	1
K434	MN35A1780	ホルダ	Holder	1

□ 付属品  
 ACCESSORIES

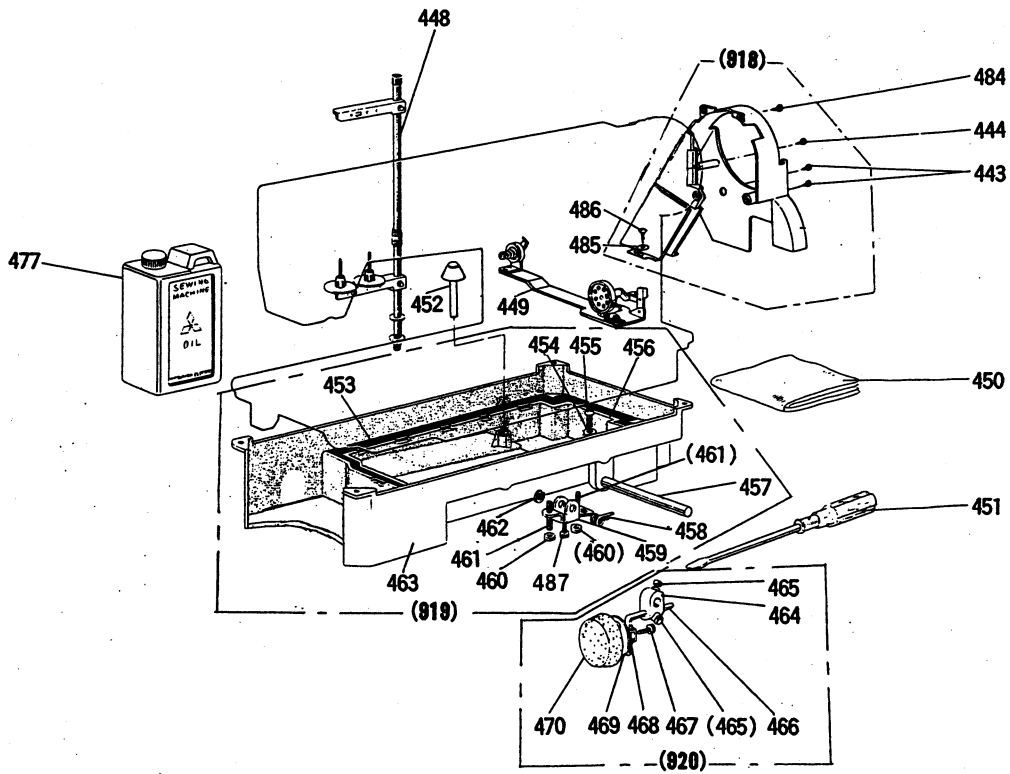
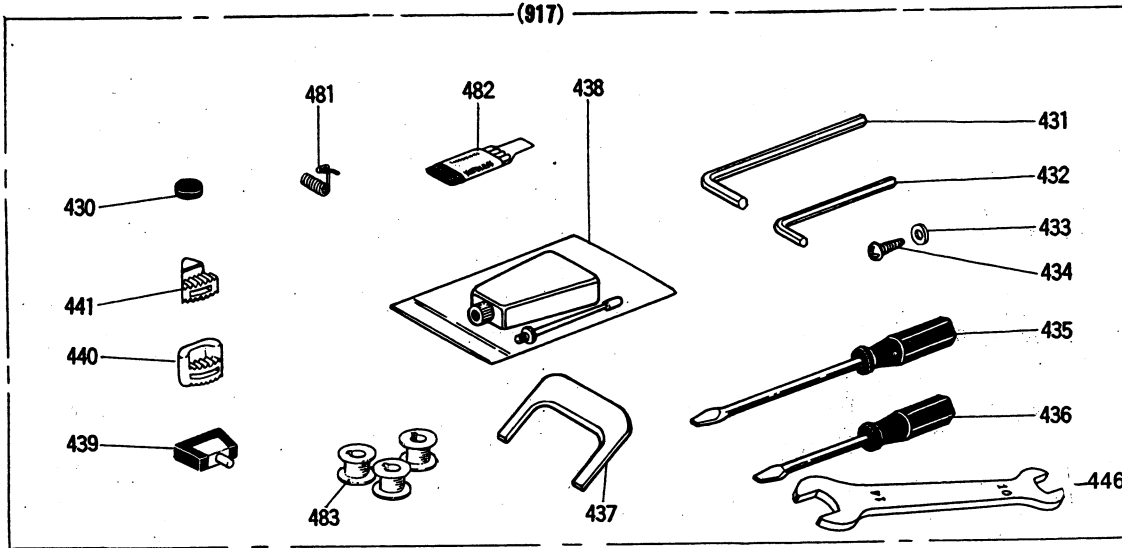

## L 付属品

## ACCESSORIES

Fig. 変更 部品コード				使用数
No.	Mod.	Parts.No.	部品名	Amt. Req.
L430		M90701099	OP-S ジシヤク	1
L431		MS02A2976	スパナ ロツカクホウ	1
L432		MS02A0976	ロツカクホウ スパナ 2	1
L433		M90550050	ミガキザガネ 5	2
L434		M90409041	マルモクネジ 4.5X20	2
L435		MF06A0608	ネジ マワシ(チウ)	1
L436		MF06A1608	ネジ マワシ(シヨウ)	1
L437		MF01A0565	カクト チヨウセイグ	1
L438		MF60A0137	アブラサシ	1
L439		MF01E0418	チヨウバンセット	2
L440		MF01A0419	ホウシンゴム	2
L441		MF01A1419	ホウシンゴム	2
L443		M91508004	ブライネジ	2
L444		M91075004	SW-PWツキ Ptハネジ	1
L446		MM10A1479	スパナ マルカタ	1
L448		MH10E0193	イトタテアイセット	1
L449		MF06E0190	イトマキシカケ	1
L450		MN70A0734	ビンニールカバー	1
L451		MF00A0608	ネジ マワシ(ダイ)	1
L452		MF70A0578	ヒザアゲピン	1
L453		MF20A3691	ガスケット	1
L454		M97001052	トクシヤガネ	1
L455		M92002002	ヒラネジ	1
L456		MF20A2691	ガスケット	1
L457		MG75A1723	ヒザアゲジク	1
L458		MF20A1729	ヒネリハネ	1
L459		MF20A1724	ヒザアゲレバ	1
L460		M91501045	ナット	2
L461		M91520001	トメネジ	2
L462		M90515065	Eガタメワ 9	1
L463		MF01A1139	アブラソウ	1
L464		MF40A0784	ツギテ	1
L465		M92003031	トクシヤホルト	2
L466		MF20A0728	ソウサホウ	1
L467		M91510022	ホルト	1
L468		MF40A0477	ストツパ	1
L469		MF40A0737	ヒザアテ	1
L470		MF40A1737	ヒザアテ	1
L477		MF10E0149	アブラカン	1
L481		MF10A0187	イトトリハネ	1
L482		MF06E0128	ハリセット	1
L482		MN36E0128	ハリセット	1
L483		MF00A0123	ホビン	3
L484		M91109004	ザガネツキブライネジ	2
L485		M90511050	ミガキザガネ 5	2
L486		M90409041	マルモクネジ 4.5X20	2
L487		M91502002	ヒラネジ	1
L918		MF01E0776	ベルトカバーセット	1
L918		MF33E0776	ベルトカバーセット	1
L919		MF90E0139	アブラソウセット	1
L920		MF40E0727	ヒザアテセット	1



## 索引

## INDEX-1

部品コード Parts. No.	ページ Page	Fig No.	部品コード Parts. No.	ページ Page	Fig No.	部品コード Parts. No.	ページ Page	Fig No.
M70828050	P18	J407	M90943003	P2	A46	M91502050	P8	D153
M74008052	P18	J405	M91000085	P10	E210	M91503031	P12	F232
M78003033	P18	J408	M91004080	P14	G332	M91504031	P12	F238
M90106053	P2	A13	M91018099	P16	H334	M91505002	P10	E193
M90204060	P2	A39	M91019099	P18	J383	M91506001	P8	D124
M90204099	P16	H364	M91075004	P22	L444	↑	P12	F252
M90304053	P20	K420	M91101046	P2	A33	M91508001	P2	A18
M90308037	P18	J381	M91103004	P20	K417	M91508004	P22	L443
M90309037	P18	J406	M91106001	P6	C512	M91510002	P14	G275
M90311050	P6	C518	↑	P8	D142	M91510022	P22	L467
M90312065	P6	C532	M91106003	P18	J399	M91512022	P14	G298
M90315065	P8	D118	M91106004	P6	C510	M91513001	P4	B83
M90320065	P4	B89	↑	P8	D156	↑	P8	D159
M90330065	P16	H351	↑	P14	G313	↑	P10	E201
M90400085	P12	F249	↑	P16	H368	M91515002	P8	D148
M90409041	P22	L434	M91106011	P2	A24	↑	P10	E208
↑	P22	L486	M91107002	P2	A16	↑	P18	J402
M90421050	P18	J409	M91107045	P14	G305	M91515015	P16	H339
M90450050	P16	H358	M91108001	P2	A07	M91516001	P4	B104
M90454050	P18	J395	↑	P6	C502	M91516002	P10	E180
M90504065	P10	E175	↑	P6	C526	↑	P14	G318
↑	P14	G316	↑	P6	C536	M91520001	P22	L461
↑	P16	H369	↑	P12	F251	M91521002	P8	D122
↑	P18	J403	M91108002	P20	K433	↑	P10	E226
M90505065	P16	H360	M91109004	P2	A10	M91601001	P6	C527
M90511050	P22	L485	↑	P14	G330	M91602001	P4	B86
M90513065	P18	J394	↑	P16	H372	↑	P8	D158
M90515065	P22	L462	↑	P22	L484	↑	P14	G319
M90516063	P14	G276	M91110004	P2	A04	M91602020	P8	D139
↑	P16	H338	M91110045	P14	G288	M91606001	P4	B78
M90519060	P10	E176	M91111004	P2	A23	M91610001	P4	B103
M90520060	P14	G322	↑	P16	H330	M91610046	P2	A44
M90550050	P22	L433	M91111015	P14	G303	M91801002	P4	B76
M90552050	P6	C514	M91112002	P8	D154	M91802006	P4	B75
M90573080	P2	A05	↑	P10	E198	M91910080	P2	A02
M90600085	P10	E185	M91113002	P4	B74	M92002002	P22	L455
M90604002	P2	A28	↑	P8	D123	M92003031	P22	L465
M90604050	P18	J385	↑	P14	G320	M92004080	P10	E179
M90619050	P8	D110	M91116002	P2	A09	M92005080	P6	C533
M90701099	P22	L430	M91117002	P14	G306	M92074045	P14	G279
M90703065	P14	G282	↑	P16	H362	M92201047	P20	K427
M90740080	P8	B80	M91118002	P8	D131	M92701080	P2	A12
M90800086	P4	D135	↑	P14	G315	M93001050	P16	H350
M90801004	P20	K419	M91127015	P14	G269	M93002050	P16	H353
M90802002	P14	G271	M91131002	P12	F255	M93003099	P14	G278
M90803010	P14	G308	M91151010	P14	G312	↑	P16	H367
M90806002	P6	C517	M91182080	P2	A01	↑	P18	J400
↑	P8	D112	M91201045	P14	G290	M93008050	P4	B91
↑	P18	J404	M91203002	P6	C500	M93202047	P12	F258
M90810002	P20	K418	↑	P6	C515	M93220035	P12	F257
M90815002	P4	B72	↑	P6	C537	M94002099	P18	J401
M90883080	P2	A03	M91204003	P6	C524	M94003099	P14	G331
M90901002	P2	A35	↑	P8	D116	M94006052	P14	G309
M90902011	P4	B92	M91207003	P10	E188	M94008037	P14	G277
M90903002	P10	E204	M91215002	P10	E221	M95003053	P10	E186
↑	P14	G314	M91219015	P12	F231	M95003067	P12	F235
M90904011	P6	C508	M91252045	P8	D164	M97001052	P22	L454
M90904060	P8	D149	M91257030	P8	D163	M97003095	P16	H341
M90904063	P10	E178	M91259030	P8	D133	M97061095	P18	J384
M90905002	P10	E203	M91276004	P16	H359	M97082030	P14	G264
M90907010	P14	G286	M91373045	P14	G273	M97084030	P20	K429
M90908003	P2	A17	M91402050	P6	C531	M97085030	P8	D126
M90910033	P18	J389	M91472086	P4	B94	M97087030	P8	D127
M90913001	P14	G283	M91501007	P10	E191	M97104099	P16	H366
M90921002	P10	E223	M91501045	P22	L460	MB60A1620	P16	H342
↑	P14	G317	M91501085	P2	A34	ME20A0406	P16	H915
M90939002	P12	F244	M91502002	P16	H344	MF00A0123	P8	D129
↑	P20	K410	↑	P22	L487	↑	P22	L483
M90942003	P8	D162	M91502045	P14	G267	MF00A0180	P14	G285

## 索引

## INDEX - 2

部品コード Parts. No.	ページ Page	Fig No.	部品コード Parts. No.	ページ Page	Fig No.	部品コード Parts. No.	ページ Page	Fig No.
MF00A0181	P2	A29	MF01A0632	P10	E189	MF30A0460	P8	D151
MF00A0253	P12	F248	MF01A0682	P16	H343	MF30A0572	P12	F236
MF00A0257	P10	E220	MF01A0691	P16	H335	MF33E0776	P22	L918
MF00A0267	P12	F246	MF01A0694	P16	H346	MF36A0245	P2	A32
MF00A0279	P8	D120	MF01A0841	P10	E217	MF36A0750	P14	G270
MF00A0289	P10	E202	MF01A0880	P16	H336	MF36A1180	P2	A08
MF00A0352	P14	G296	MF01A1139	P22	L463	MF40A0331	P4	B87
MF00A0417	P18	J392	MF01A1245	P8	D128	MF40A0333	P4	B88
MF00A0450	P8	D137	MF01A1419	P22	L441	MF40A0477	P22	L468
MF00A0451	P8	D136	MF01A1476	P16	H348	MF40A0729	P16	H370
MF00A0452	P8	D143	MF01A1694	P16	H347	MF40A0737	P22	L469
MF00A0453	P8	D140	MF01A2601	P18	J386	MF40A0784	P22	L464
MF00A0454	P8	D121	MF01E0252	P12	F250	MF40A1530	P16	H361
MF00A0521	P4	B98	MF01E0331	P4	B905	MF40A1737	P22	L470
MF00A0572	P8	D146	MF01E0332	P4	B906	MF40A1750	P20	K415
MF00A0608	P22	L451	MF01E0350	P8	D138	MF40A3339	P16	H363
MF00A0633	P10	E190	MF01E0351	P14	G912	MF40A3601	P16	H365
MF00A0729	P14	G295	MF01E0352	P8	D141	MF40E0727	P22	L920
MF00A0750	P14	G300	MF01E0411	P14	G291	MF40E2484	P18	J387
MF00A0753	P8	D145	MF01E0418	P22	L439	MF60A0137	P22	L438
MF00A0780	P14	G272	MF01E0477	P14	G294	MF70A0128	P4	B73
MF00A0834	P14	G311	MF01E0640	P10	E922	MF70A0286	P8	D152
MF00A0836	P14	G310	MF01E0746	P14	G262	MF70A0350	P12	F239
MF00A0852	P10	E213	MF01E0776	P22	L918	MF70A0384	P4	B97
MF00A0950	P10	E215	MF02A0245	P10	E222	MF70A0491	P8	D117
MF00A1152	P10	E173	MF05A0234	P4	B84	MF70A0511	P12	F234
MF00A1352	P14	G266	MF05A0572	P10	E211	MF70A0522	P4	B100
MF00A1386	P4	B96	MF05A0660	P4	B70	MF70A0578	P22	L452
MF00A1391	P14	G263	MF05A0740	P8	D134	MF70A0738	P12	F230
MF00A1392	P14	G307	MF05A0780	P8	D160	MF70A0750	P10	E177
MF00A1454	P10	E195	MF05A0910	P8	D161	MF70A1180	P2	A45
MF00A1477	P14	G297	MF05E0580	P4	B904	MF80A0154	P8	D147
MF00A1509	P14	G274	MF06A0572	P18	J388	MF80A0181	P2	A19
MF00A1527	P14	G302	MF06A0608	P22	L435	MF80A0232	P4	B81
MF00A1603	P14	G284	MF06A1519	P18	J382	MF80A0277	P8	D150
MF00A1691	P16	H337	MF06A1608	P22	L436	MF80A0352	P4	B85
MF00A1729	P14	G265	MF06E0128	P22	L482	↑	P8	D157
MF00A1950	P12	F240	MF06E0190	P22	L449	MF80A0688	P8	D144
MF00A2454	P10	E199	MF06E3519	P14	G911	MF80A0783	P20	K416
MF00A2601	P20	K423	MF10A0151	P2	A14	MF80A1572	P20	K430
MF00A2910	P10	E196	MF10A0181	P2	A20	MF80A1688	P20	K414
MF00A3708	P10	E212	MF10A0187	P2	A37	MF80E0470	P2	A901
MF00A3910	P10	E197	↑	P22	L481	MF85A0640	P10	E214
MF00A4708	P10	E224	MF10A0229	P8	D130	MF90A0278	P8	D115
MF00A5454	P14	G301	MF10A0325	P4	B79	MF90A0283	P8	D114
MF00A5572	P10	E183	MF10A0332	P4	B102	MF90A0361	P14	G268
MF00A5910	P18	J393	MF10A0334	P4	B101	MF90A0383	P4	B77
MF00A6572	P10	E225	MF10A0471	P2	A27	MF90A0553	P2	A30
MF00A6910	P10	E172	MF10A0520	P4	B99	MF90E0139	P22	L919
MF00A7910	P10	E174	MF10A0553	P2	A38	MF95A0148	P20	K432
MF00A8910	P14	G304	MF10A0555	P2	A40	MG34E0519	P16	H332
MF00A9572	P14	G299	MF10A0685	P20	K425	MG68A0366	P16	H333
MF00E0142	P20	K426	MF10A0709	P2	A36	MG75A0285	P8	D119
MF00E0252	P12	F905	MF10A1555	P2	A31	MG75A1723	P22	L457
MF00E0550	P2	A902	MF10A1742	P20	K421	MH10E0193	P22	L448
MF00E1635	P10	E184	MF10E0149	P22	L477	MH40A0556	P2	A41
MF01A0233	P4	B93	MF10E0337	P20	K422	MM10A1479	P22	L446
MF01A0257	P16	H352	MF11D0245	P2	A42	MN35A0104	P8	D113
MF01A0259	P16	H349	MF11D0262	P12	F247	MN35A0125	P8	D909
MF01A0339	P18	J380	MF12B0259	P12	F254	MN35A0181	P4	B71
MF01A0378	P20	K428	MF13A0120	P8	D132	MN35A0257	P6	C507
MF01A0379	P14	G281	MF20A0135	P2	A11	MN35A0265	P12	F253
MF01A0419	P22	L440	MF20A0703	P12	F256	MN35A0273	P6	C501
MF01A0454	P18	J396	MF20A0728	P22	L466	MN35A0284	P6	C522
MF01A0476	P16	H345	MF20A1724	P22	L459	MN35A0285	P6	C521
MF01A0557	P8	D125	MF20A1729	P22	L458	MN35A0392	P6	C535
MF01A0565	P22	L437	MF20A2691	P22	L456	MN35A0454	P6	C523
MF01A0601	P2	A15	MF20A3691	P22	L453	MN35A0530	P6	C504
MF01A0631	P10	E216	MF30A0252	P12	F233	MN35A0601	P20	K411

## 索引

## INDEX-3

部品コード Parts. No.	ページ Page	Fig No.
MN35A0628	P4	B95
MN35A0662	P6	C513
MN35A0667	P6	C509
MN35A0691	P2	A21
MN35A0740	P6	C519
MN35A0761	P6	C538
MN35A0780	P20	K412
MN35A0833	P6	C511
MN35A0838	P14	G287
MN35A0910	P6	C503
MN35A0950	P16	H356
MN35A0980	P18	J398
MN35A0982	P18	J397
MN35A1101	P2	A25
MN35A1273	P6	C525
MN35A1285	P6	C530
MN35A1530	P10	E171
MN35A1628	P6	C516
MN35A1691	P6	C506
MN35A1780	P20	K434
MN35A1910	P6	C534
MN35A2530	P10	E200
MN35A3530	P10	E205
MN35A4530	P10	E206
MN35E0173	P14	G321
MN35E0276	P8	D155
MN35E0666	P6	C505
MN36A0339	P16	H357
MN36A0417	P16	H340
MN36A0492	P4	B90
MN36A0584	P2	A06
MN36A0660	P4	B70
MN36A0830	P2	A22
MN36E0105	P12	F243
MN36E0128	P22	L482
MN36E0210	P2	A903
MN36E0230	P4	B82
MN36E0281	P8	D111
MN36E0519	P16	H913
MN36E0534	P16	H916
MN36E0666	P6	C505
MN36E0694	P16	H914
MN36E0731	P20	K413
MN36E0984	P18	J917
MN50A0780	P16	H371
MN60A0620	P16	H331
MN70A0734	P22	L450
MN70E0148	P20	K431
MS02A0976	P22	L432
MS02A2976	P22	L431
MT60A0352	P6	C528
MT60A0802	P2	A43
MV01A0128	P4	B73



お問い合わせは下記へどうぞ

FAシステム事業本部 機器計画部 駆動機器グループ 〒100-8310 東京都千代田区丸の内 2-7-3 (東京ビル)

代表電話番号 (03)3218-6631 代表FAX番号 (03)3218-6823



FACTORY AUTOMATION SYSTEM GROUP

2-7-3, Marunouchi Chiyoda-ku Tokyo 100-8310, Japan

Fax : +81-3-3218-6821