



INDUSTRIAL SEWING MACHINE

MODEL

XC-G500-Y (Mitsubishi Limiservo X G, K series)

TECHNICAL MANUAL

CONTROL-SWICH PANEL

Thank you for choosing the XC-G500-Y control panel. Please read this user manual carefully prior to usage.

Contents	Page
1. HANDLING INSTRUCTIONS	1
2. INSTALLATION PROCEDURE	1
3. SELECTION OF MODE	2
4. KEY NAMES AND FUNCTIONS	2
5. OPERATION PROCEDURES	5
Straight Lock Stitching	5
Backtacking	5
Continuous Backtacking	6
Using the Trimming Key	6
Using the Automatic Key	7
Using the Needle Up Key	7
Using the Manual Stitching Key	7
Setting the Pattern by Teaching Input	8
Setting the Pattern by Program Input	9
Correcting the Data Programmed for Patterns A to H	10
Using the Continuous Key	11
Using the Function Key	12
Using the Sensor Key	12
Using the Program Keys	13
Settings Data Copy Function	13
6. ERROR DISPLAY	13

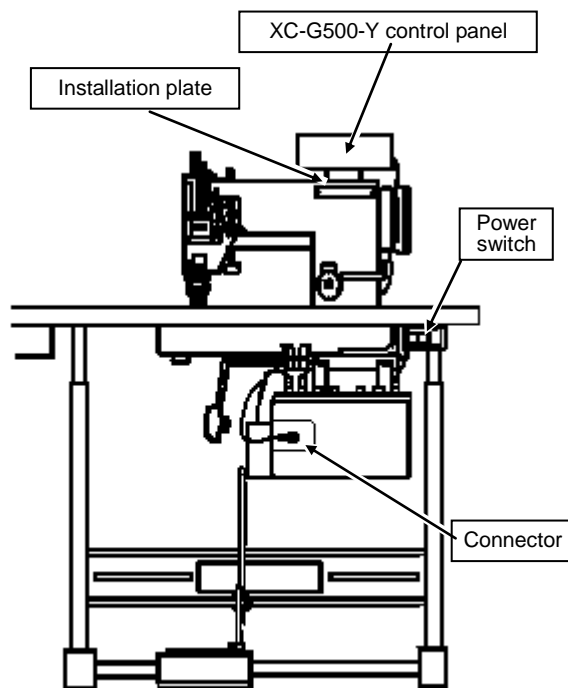

Fig. 1 Configuration

1. HANDLING INSTRUCTIONS

- (1) Ensure to always connect the XC-G500-Y control panel to the Limi-Servo XC-G or XC-K Series control box. The XC-G500-Y control panel cannot be used with other control boxes (XC-E, XC-F, XC-H Series etc.).
- (2) In the interests of safety, always turn OFF the power switch before inserting and removing the connector. Please be aware that the control panel or control box may be damaged, and the memory contents may be corrupted if the connector is inserted or removed with the power ON.
- (3) Wipe off any machine oil adhering to the control panel with a soft cloth. There is a possibility of color change, deformation, or peeling of the surface sheet if the control panel is left with oil adhering to it. Please wipe with a neutral detergent if excessively dirty. Use of solvent will result in color change and deformation, and therefore should not be used.

2. INSTALLATION PROCEDURE (See Fig. 1.)

- (1) Turn OFF the power switch.
- (2) Use the installation plate and screws provided, and install using the machine arm back plate tightening screws and so forth.
- (3) Exercise extreme caution to ensure lead wires do not come into contact with the rotating body like the belt, pulley and so on.
- (4) Connect the control panel connector firmly to the control box connector (see Fig. 1).
- (5) The pattern display area are lighted when the power is turned ON.

3. SELECTION OF MODE

There are 2 kinds of modes in the control panel

- 1) G10 mode : Display of setting data for control box like sewing machine direction, sewing machine speed and so on (The same display as the XC-G10 control panel)
- 2) Control panel mode : Display of backtacking data, program input data, teaching input data and so on. (The specific display of the XC-G500 control panel)

Please select them for your purpose.
(Factory setting is G10 mode)

How to change mode

Press the **F** key while pressing the **STEP** key
The previous mode is returned at the same operation.

Note: Mode is not changed while the **INPUT** is lighted on control panel mode.

Press the **OUTPUT** key and after the **INPUT** is turned of the light, it is possible to change mode.

Please refer to the instruction manual of XC-G or XC-K Series to operate G10 mode.

The control panel mode is described in this technical information as below.

4. KEY NAMES AND FUNCTIONS

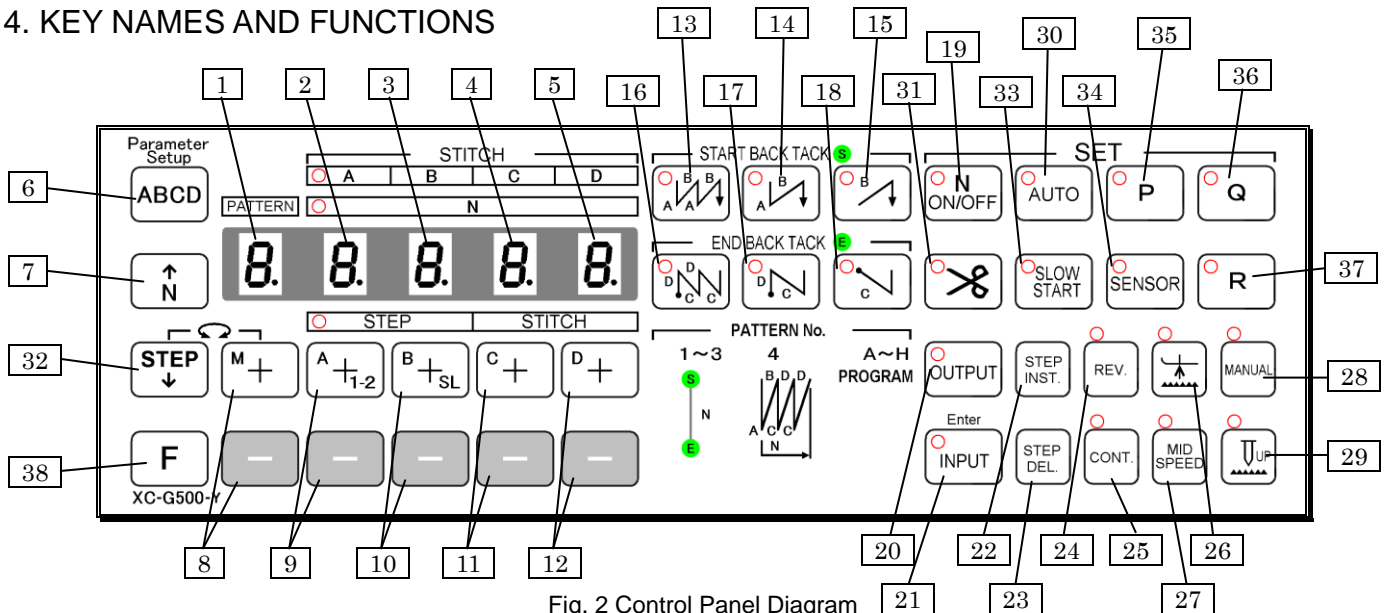

Fig. 2 Control Panel Diagram

Keys Related to Start/end backtacking

1 **PATTERN**
8. Pattern display area
Displays the pattern number.

2 **8. 8. 8. 8.**
3
4
5
Stitch number display area
Displays the stitch number for start, end backtacking and fixed-stitch stitching, and steps etc.

6 **ABCD** Backtacking stitch number display selection key **⚙️ A B C D**
Used to change the display at the stitch number display area to the backtacking stitch number. The LED illuminates when enabled.

7 **↑ N** Stitch number (N) display selection key for fixed-stitch stitching **⚙️ N**
Used to change the display at the stitch number display area to the stitch number (N) for fixed-stitch stitching. The LED illuminates when enabled.

Pattern No.	Pattern
1 to 3	Straight lock stitching/Back tacking/Stitching with fixed stitches
4	Continuous backtacking
A to H	Programming/teaching



8 Pattern number setting key (some of the setting value selection keys)
 Used to select a pattern.
 Patterns 1 to 3: Standard lock stitching/fixed-stitch stitching
 Pattern 4: Continuous backtacking
 Patterns A to H: Programming/teaching

9 Setting value selection key
 These other keys are used to change the setting values above the keys.
10
11
12

13
14
15 Start backtacking selection key
 Used to select start backtacking.
: W-shaped backtack : N-shaped backtack : V-shaped backtack
 No selection: Backtacking not performed.

When these 3 keys are pressed simultaneously, it is possible to specify a repeat operation count from 1 to 7 times. (The maximum number of times can be set using the Program mode (D mode) "BTM" function.) (Factory setting is 6 times.)

16
17
18 End backtacking selection key
 Used to select end backtacking.
: W-shaped backtack : N-shaped backtack : V-shaped backtack
 No selection: Backtacking not performed.

When these 3 keys are pressed simultaneously, it is possible to specify a repeat operation count from 1 to 7 times. (The maximum number of times can be set using the Program mode (D mode) "BTM" function.) (Factory setting is 6 times.)

19 Fixed-stitch stitching ON/OFF selection key
 Used to enable or disable fixed-stitch stitching (N).

Keys Related to Program/Teaching

20 Output keys (used for patterns A to H)

21 Input keys (used for patterns A to H)

22 Step insert key (used for patterns A to H)
 Used to insert a step during program correction when the key is lighted.

23 Step delete key (used for patterns A to H)
 Used to delete a step during program correction when the key is lighted.

24 Reverse stitching key (used for patterns A to H)
 Used for reverse stitching during stitching operation.

25 Continuous key (used for patterns A to H)
 Used for continuous stitching of steps during stitching operation.
 See Using the Continuous Key for further details. (Page 11)

26 Presser foot up key (used for patterns A to H)
 Used for presser foot lifting at the end of stitching

27 Middle speed key (used for patterns A to H)
 Used for middle-speed stitching for the corresponding step during stitching operation



Manual key (used for patterns A to H)

Used for manual stitching for the corresponding step during stitching operation.

See [Using the Manual Key](#) for further details. (Page 7)

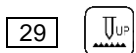

Needle up key (used for patterns A to H)

By pressing this key when the needle is not at the UP position, the sewing machine rotates to the needle UP position and stops.

See [Using the Needle UP Key](#) for further details. (Page 7)

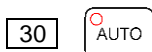

Automatic key

Used for stitching by toeing the pedal once during stitching operation. See [Using the Automatic Key](#) for further details. (Page 7)



Trimming key

Used for thread trimming at the end of step. See [Using the Trimming Key](#) for further details. (Page 6)



Step display selection key (used for patterns A to H)

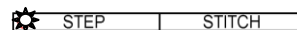

Used to change the display at the stitch number display area to step, stitch number. The LED illuminates when enabled.

Other Keys



Slow start key

Used for slow start at the start of stitching.

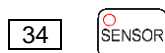

Sensor key

Used for the edge sensor and so on. See [Using the Sensor Key](#) for further details. (Page 12)

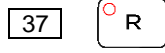
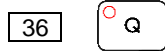

Program key

This can be used for customizing (arbitrary input function) using the functions on the main unit control box. See [Using the Program Key](#) for details of simple usage methods. (Page 13)



Function key

Used to change the display mode. See [Using the Function Key](#) for further details. (Page 12)

5. OPERATION PROCEDURES

With the exception of the keys, all key operations are disabled during stitching (during machine operation). (Cannot be changed even by pressing the keys.)

Straight Lock Stitching

(1) Standard lock stitching (manual stitching)

Press pattern number setting key while watching pattern number display area to select from patterns 1 to 3.

Setting the stitch edge: Turn all start backtacking buttons and end backtacking buttons OFF.

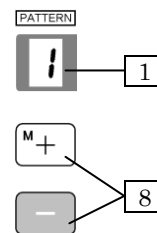

(2) Fixed-stitch stitching

Press pattern number setting key while watching pattern number display area to select from patterns 1 to 3.

Press the key and setting the number of stitches for fixed-stitch stitching is valid.

Setting the stitch edge: Turn all start backtacking buttons and end backtacking buttons OFF.

Setting the number of stitches for fixed-stitch stitching: Press the key to change the display to "N". Set the number of stitches using setting value selection keys when the LED illuminates. A setting value of "0" to "9999" is possible. (Manual stitching is performed if set to "0".)

Backtacking

Press pattern number setting key while watching pattern number display area to select from patterns 1 to 3.

(1) Start backtacking

*Select the start backtacking type from the start backtacking selection keys (, ,) (Start backtacking is not performed if no selection is made.)

*Press the key () to set the number of start backtacking stitches. The LED illuminates and the number of backtacking stitches (A, B) displays at the stitch number display area (,) . While watching these values, set the number of stitches using the setting value selection keys (,) .



(2) End backtacking

*Select the end backtacking type from the end backtacking selection keys (, ,) (End backtacking is not performed if no selection is made.)

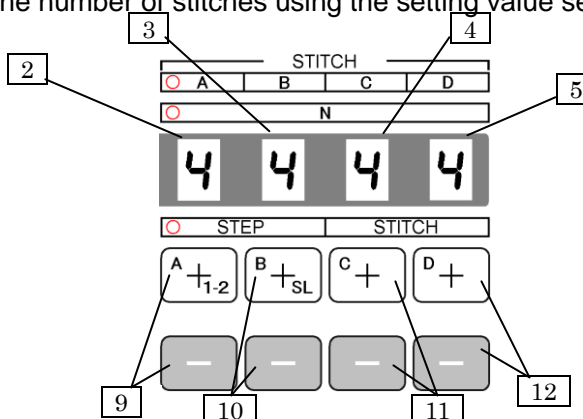

*Press the key () to set the number of end backtacking stitches. The LED illuminates and the number of backtacking stitches (C, D) displays at the stitch number display area (,) . While watching these values, set the number of stitches using the setting value selection keys (,) .





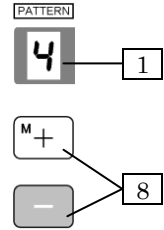







Continuous Backtacking









While watching pattern number display area , select pattern 4 using pattern selection key .



*Press the  key () to set the number of stitches.

The  A B C D LED illuminates and the number of stitches (A, B, C, D) displays at the stitch number display area (, , , ). While watching these values, set the number of stitches using the setting value selection keys (, , , ).

*Press the  key () to set the number of times the operation is performed.

The  N LED illuminates and the number of times (N) displays at the stitch number display area (, , , ). While watching these values, set the number of times using the setting value selection keys (, , , ).





Press the  key and setting the number of stitches for fixed-stitch stitching is valid.

- Notes**
1. When forced full pedal heeling is performed during the pattern, end backtacking will be performed.
 2. The pattern and start backtacking cannot be changed when stopped during the pattern. End backtacking type can be changed.
 3. Change of the pattern, start and end backtacking have to be done after full pedal heeling.

Using the Trimming Key











Basically, thread trimming is performed when the LED in the upper left of the trimming key  is illuminated. The operation, however, will differ depending on the condition. Please refer to the following for further details.

1. Standard lock stitching (manual stitching) (continuous backtacking) Patterns 1 to 4 :To trim the thread at the end of stitching (pedal heeling operation), press the  key to turn ON the LED in the upper left of the key. To cancel thread trimming at the end of stitching (pedal heeling operation), press the  key to turn OFF the LED in the upper left of the key. Thread trimming will not be performed when the LED is not illuminated. (This only applies when the sewing machine stops at the UP position after the set end backtacking is performed.)
2. Fixed-stitch stitching (continuous backtacking) Patterns 1 to 4 :To stop the sewing machine after fixed-stitch stitching is complete (with the pedal pressed down), press the  key before stitching to turn OFF the LED in the upper left of the key. When the LED is not illuminated, the machine stops at the specified position (UP or DOWN) following the completion of fixed-stitch stitching. Next, heel the pedal to perform the set end backtacking and thread trimming.
3. Patterns A to H :To cancel thread trimming at the end of stitching at the corresponding step in the program/teaching input mode, press the  key to turn OFF the LED in the upper left of the key. In the output mode, the sewing machine stops after stitching that step. (If the pedal is fully heeled, the thread is trimmed, and the machine returns to step 1.) The  key is disabled when in the output mode.



Using the Automatic Key



1. Standard lock stitching
Fixed-stitch stitching
Patterns 1 to 3
:When the  key is pressed and the LED in the upper left of the key turns OFF, the speed varies based on the amount of pressure applied to the pedal. (The sewing machine stops when the pedal is at the neutral position.)
When the  key is pressed and the LED in the upper left of the key turns ON, the speed is fixed at high-speed regardless of the amount of pressure applied to the pedal.
2. Continuous backtacking
Pattern 4
:The  key can be turned ON or OFF and backtacking speed is constant. (Variable speed operation can be performed by setting at the control box.)
3. Patterns A to H
:To stop the sewing machine by setting the pedal to the neutral position during stitching of the corresponding step in program/teaching input mode, press the  key to turn OFF the LED after  key to turn On. To continue automatic stitching to the end of the step even with the pedal at the neutral position during stitching of that step, press the  key to turn ON the LED after  key to turn ON. The  key is disabled when in the output mode.

Using the Needle Up Key





1. When stitching
:The needle does not rise even when the  needle UP key is pressed.
2. When in program/teaching input mode
:When the needle is not at the needle UP position, press the  needle UP key to turn ON the LED when in the program/teaching input mode to rotate to the needle UP position and stop.
Press the  needle UP key to turn ON the LED when in the program/teaching input mode to stop at the needle UP position at the end of that step in output mode.

Using the Manual Stitching Key



(The manual stitching key is only valid for patterns A to H.)

1. Input mode
:Manual stitching is performed at the step where the  manual stitching key is pressed to turn ON the LED. Raise the presser foot to shift to the next step during output of a step programmed for manual stitching.
2. Output mode
:By pressing the  manual stitching key to turn ON the LED, stitching is stopped at the current output step and manual stitching is enabled. To return to pattern stitching, press the  key again to turn OFF the LED. Stitching is then resumed from the point at which it was interrupted. Stitching is resumed from the step after the interrupted step, however, if the presser foot is raised when in manual stitching mode.

Setting the Pattern by Teaching Input

Input

Fig. 3 is used here as an example to explain pocket stitching.

(1) Set the required pattern number from A to H.

(2) Press the  input key to select input mode.
(The input LED turns ON.)

(3) Ensure that step "1" displays and stitch number "0" is flashing. (Fig. 4)

If the stitch number is not flashing, press the  key () repeatedly until stitch number "0" starts flashing.

(4) Select start backtacking using the  start backtacking selection keys,

or end backtacking using the  end backtacking selection keys. (See [Backtacking](#) for further details. Page 5)

(5) Perform actual stitching of area A shown in Fig. 3.

(5.1) Set the fabric and toe the pedal to perform straight lock stitching after performing the set start backtacking. When the pedal is returned to the neutral position after stitching area A in Fig. 3, the number of stitches made displays and flashes at the stitch number display area shown in Fig. 4.

(5.2) Next, raise the presser foot (by light heeling or by the foot switch), change the fabric direction, and lower the presser foot. Step "2" then displays at the step display area shown in Fig. 4 and stitch number "0" starts flashing at the stitch number display area.

(This completes input of the stitch number and presser foot lifting for area A.)

(6) Stitch areas B, C and D in the same manner. (This completes input of the stitch number and presser foot lifting for areas B, C and D.) Push the pedal down fully (S2 = ON) after completing stitching of area D. The set end backtacking is then performed and the threads are trimmed. (This completes final input for the stitch number and presser foot lifting.)

(7) Teaching input is complete at the above step. Next, press the  output key.

The step automatically changes to "1" and output mode is selected. If the stitch number exceeds 99 for any step, the machine automatically continues to the next set step.

(E.g. If the stitch number for area A is 140, 99 stitches are input to step 1, the  key turns ON, and the remaining 41 stitches are input to step 2.)

Caution: Ensure to press the  key after input is complete.

Input patterns are not stored in the memory if the power is turned OFF with the  key still ON (input mode).

Output

The pocket stitching input at the previous item is used here as an example to explain output.

(1) Press the  key to turn ON the LED in the upper left of the key.
The output mode is now selected.

(2) Set the pattern number for the pattern to be stitched. (The diagram on the right indicates that pattern A has been set.)

(3) The display shows step "1" and the stitch number input for area A (Fig. 3).

(4) Set the fabric and press the pedal to perform fixed-stitch stitching of area A (input stitch number) after performing the set start backtacking, and the presser foot rises automatically after the needle stops at the DOWN position. Next, change the fabric direction. At this time, the display automatically indicates the next step to be stitched.

(5) Stitch areas B, C and D in the same manner.

The set end backtacking is performed when fixed-stitch stitching of area D is complete, and the presser foot rises after the threads have been trimmed. This completes output, however, the step number has already returned to "1", and the same stitching is repeated when the pedal is pressed again.

- Notes:**
1. The pattern cannot be changed when stopped during program or teaching output. Always ensure to fully heel the pedal or perform thread trimming.
 2. The step always returns to the first step (step 1) if thread trimming is performed during output of the program or teaching.
 3. Only end backtacking can be changed when stopped during program or teaching output. The end backtacking stitch number, however, cannot be changed.

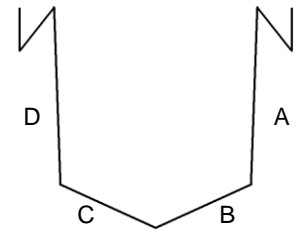
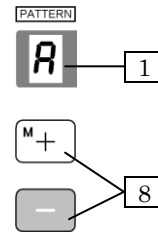

Fig. 3 Pocket stitching



Fig. 4 Step and stitch number display

Setting the Pattern by Program Input

Input

Fig. 5 is used here as an example to explain label stitching.

- (1) Set the required pattern number from A to H.
- (2) Press the  input key to select input mode.
- (3) Ensure that step "1" displays and stitch number "0" is flashing. (Fig. 6)

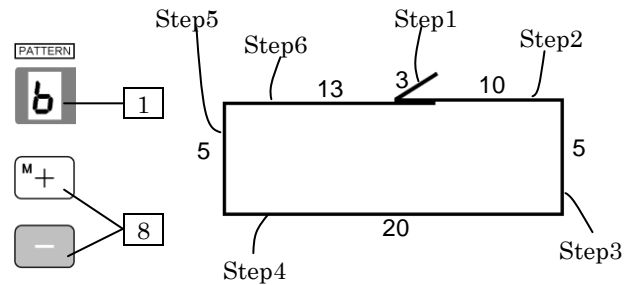



Fig. 5 Label stitching



Fig. 6 Step and stitch number display

If the stitch number is not flashing, press the  key (**23**) repeatedly until stitch number "0" starts flashing.

- (4) Step 1 can be input even with the  start backtacking key, however, the method explained here does not use this key, and therefore start and end backtacking are not performed.

- (5) Setting step 1 (Backward stitching of 3 stitches at middle speed without stopping)

(5.1) Press the setting value selection key (**12**) and set the stitch number to "3".



(5.2) Press the  middle speed key (**27**) to turn ON the LED. (Middle speed when in output mode)

(5.3) Press the  continuous key (**25**) to proceed to the next step without stopping.

(5.4) Press the  reverse stitching key (**24**) to specify reverse stitching.

(5.5) Step 1 setting is now complete. Press the  step key (**10**) to change the displayed step to "2". At this time, the number of stitches displayed is "0" and flashes.

- (6) Setting step 2 (10 stitches at pedal speed, presser foot lifted and stopped)



(6.1) Press the    setting value selection keys (**11**, **12**) and set the stitch number to "10".

(6.2) Press the  presser foot up key to lift the presser foot after stopping.

(6.3) Step 2 setting is now complete. Press the  step key (**10**) to change the displayed step to "3". At this time, the number of stitches displayed is "0" and flashes.

- (7) Set steps 3 to 5 in the same manner.

- (8) Setting step 6 (13 stitches at pedal speed with automatic thread trimming followed by presser foot lifting)

(8.1) Press the    setting value selection keys (**11**, **12**) and set the stitch number to "13".

(8.2) Press the  trim key (**31**) to turn ON the LED and perform thread trimming.

(8.3) Press the  presser foot up key to lift the presser foot after stopping.

- (9) Program input is complete at the above step. Next, press the  output key (**20**). The step automatically changes to "1" and output mode is selected.



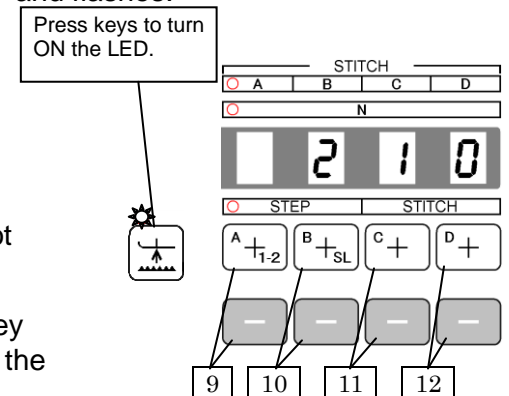
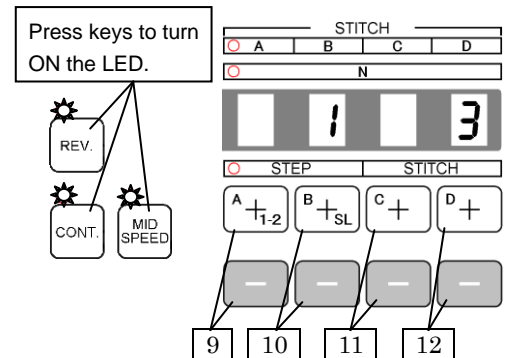

Caution: Ensure to press the  key after input is complete.

Input patterns are not stored in the memory if the power is turned OFF with the  key still ON (input mode).



Output

The label stitching input at the previous item is used here as an example to explain output.

- (1) Press the  output key (**20**) to turn ON the LED in the upper left of the key. The output mode is now selected.
- (2) Set the pattern number by pressing the pattern number setting key. (The drawing on the right shows the case when B is set.)
- (3) The display shows step "1", a stitch number of "3", and the    key LEDs are illuminated. (Fig. 7)

- (4) Press down the pedal to perform backtacking at middle speed followed by label pattern stitching. (3 stitches back, 10 stitches forward, stop, presser foot lift, 5 stitches forward, stop, presser foot lift, 20 stitches forward, stop, presser foot lift, 5 stitches forward, stop, presser foot lift, 20 stitches forward, stop, presser foot lift, 5 stitches forward, stop, presser foot lift, 13 stitches forward, thread trimming stop, presser foot lift) After stitching, the step will automatically return to step 1 as shown in Fig. 7. The same stitching is repeated when the pedal is pressed again.

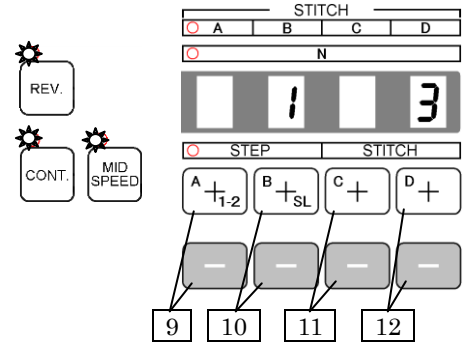
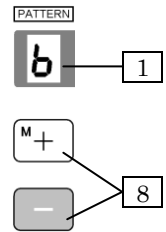









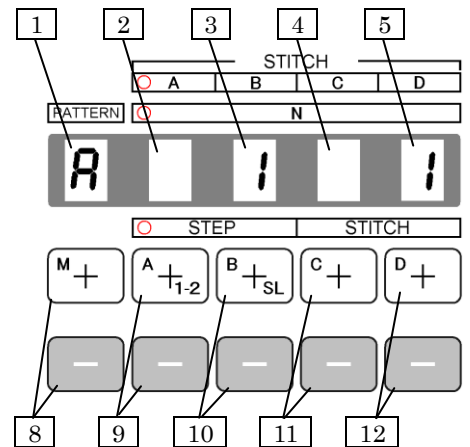

Fig. 7 Output mode display

Correcting the Data Programmed for Patterns A to H











1. Correcting the Stitch Number

- (1) Press the   pattern selection keys (**8**) to set the number for the pattern to be corrected while watching the pattern number display area (**1**).
- (2) Press the  input key (**21**) to select input mode.
- (3) Next, press the    step selection keys (**9**, **10**) to set the (process) number for the step to be corrected while watching the step display area (**2**, **3**).
- (4) Next, press the    stitch number selection keys (**11**, **12**) to set the stitch number to be corrected while watching the stitch number display area (**4**, **5**).
- (5) Press the  output key (**20**) to select output mode.



2. Inserting Steps





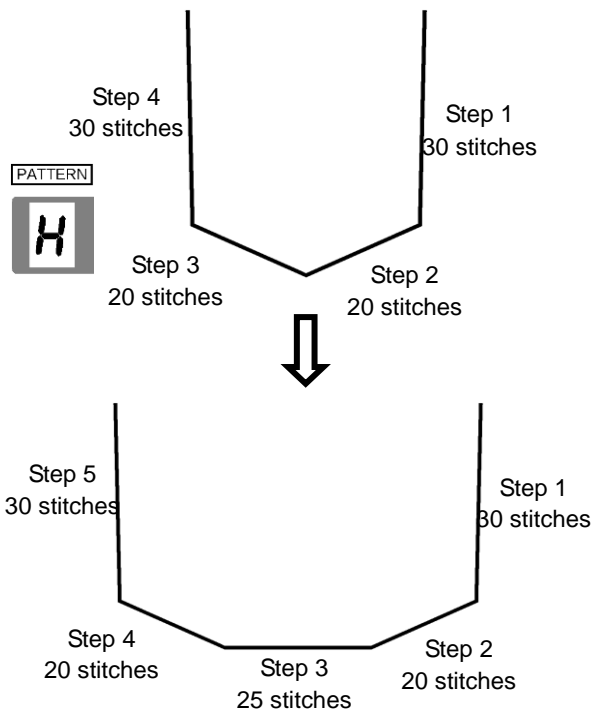



To insert a process of 25 stitches between steps 2 and 3 in a pattern with a pocket as shown in the diagram on the right, for example, please proceed as follows.

- (1) Press the   pattern selection keys (**8**) to set the pattern number for the step to be inserted while watching the pattern display area.
- (2) Press the  input key (**21**) to select input mode.
- (3) Next, set the step to "3" using the    step selection keys (**9**, **10**).
- (4) Press the  step insert key (**22**) to change the stitch number for step 3 to "0" and shift the patterns originally at step 3 and after to step 4 and after.
- (5) Set the stitch number for step 3 to "25" by pressing the    stitch number selection keys (**11**, **12**).
- (6) Input is complete at the above step. Next, press the  output key (**20**). The step automatically changes to "1" and output mode is selected.



3. Deleting Steps

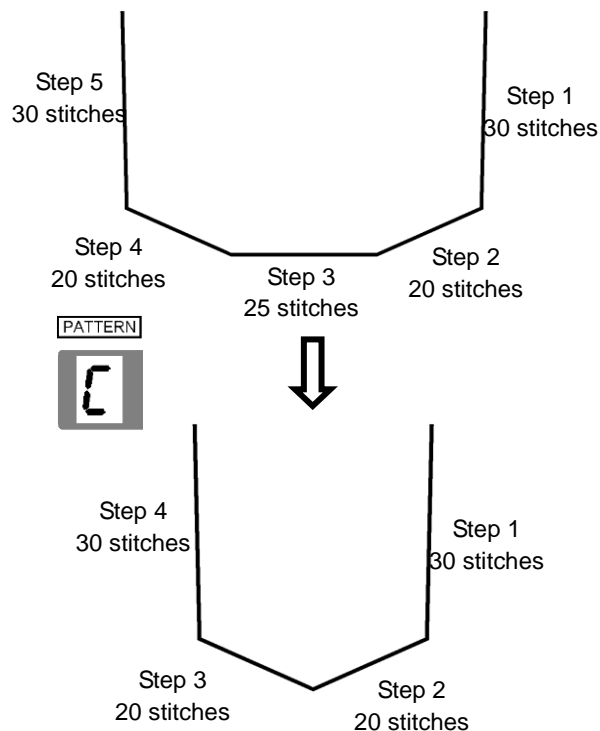

To delete step 3 from a pattern with a pocket as shown in the diagram on the right, for example, please proceed as follows.

- (1) Press the   pattern selection keys (**8**) to set the pattern number for the step to be deleted while watching the pattern display area.
- (2) Press the  input key (**21**) to select input mode.
- (3) Next, set the step to "3" using the    step selection keys (**9**, **10**).
- (4) Press the  step delete key (**23**) to delete step 3 and move step 4 and after one place up to step 3 and after.
- (5) Input is complete at the above step. Next, press the  output key (**20**). The step automatically changes to "1" and output mode is selected.





Using the Continuous Key



When inputting a program, press the  key to turn ON the LED and enable steps to be continuously stitched. Furthermore, if the  key is pressed at the final step (any step from 2 to 24) during program/teaching input and the stitch number is "0", stitching is performed sequentially with the next pattern. Use this function when the number of stitches (99) in one step, or the number of steps in one pattern (24 steps) is insufficient.

Using the Function Key

F

The  function key is enabled at times other than when performing program or teaching input (when the  LED is OFF). Turn the  key ON to escape from this mode.

The display when the  key is turned ON will be as follows based on the program mode (C mode) "CNF" function at the control box.

Program mode (C mode)	CNF=UP setting, U is displayed, which means UP counter display
Program mode (C mode)	CNF=DN setting, D is displayed, which means DOWN counter display
Program mode (C mode)	CNF=SE setting, SEN is displayed, which means Sensor stitch No. display for patterns 1 to 4
Program mode (C mode)	CNF=SP setting, S is displayed, which means Speed display

The following settings are required in order to operate the UP/DOWN counters.

To operate the UP counter:

Program mode (B mode) Set to other than P = 0 and to UPC = ON.

To operate the DOWN counter:

Program mode (B mode) Set to other than N = 0 and to DNC = ON.

Various settings can be made for the UP/DOWN counters using program "B" mode at the control box (Thread trimming count, stitch number counter etc.) Refer to the technical information manual for further details.

Notes:



1. The display is changed from U to P, Up counter setting, after Up counter clear signal is input to ON with  key when CNF is set to Up. After that U is back to on display when operating.
2. The display is changed from D to N, Down counter setting, after Down counter clear signal is input to ON when CNF is set to Dn. After that D is back to on display when operating.

Using the Sensor Key





This key is extremely handy when stitching is to be automatically stopped at the edge of the fabric. Refer to the machine technical documentation for details of the connectors to which the sensors are connected.

1. Patterns 1 to 4: The sensor is enabled when the  key is pressed and the LED illuminates.

Set the stitch number from sensor detection until the machine stops using the   keys.

- Notes:**
1. The sensor ON/OFF status and the number of stitches until the machine stops following sensor detection can be set for each pattern.
 2. Refer to the machine technical documentation for details of the needle position at sensor stoppage.

2. Patterns A to H: The sensor at the specified step is enabled when the  key is pressed and the LED illuminates when performing input. Set the stitch number from sensor detection until the machine stops using the   keys. During output, "SE" is displayed on the stitch number display.

- Notes:**
1. The stitch number which is input on the specified step will be the number of stitches at sensor stoppage.
 2. Manual stitching and sensors cannot be used simultaneously when inputting.
 3. During output, if the sensor is not to be used in a step for which it is set, move to the next step by lightly heeling the pedal, or by turning the manual stitching key

ON ( LED ON). Move to the next step by lightly heeling the pedal after manual stitching is complete.

4. The needle position at sensor stoppage can be selected using the  key. (Valid only when inputting.)

Using the Program Keys



These keys can be customized (arbitrary input functions) using the functions at the machine control box. The LED to the upper left of this key can also be customized (arbitrary display function) using the functions at the machine control box. The default settings for this key are as follows.

*Switch input functions:

: UP counter clear(CCU) : Not used (NO) : Not used (NO)

*Lamp output functions:

: Not used (NO)

Refer to the machine technical documentation for details on setting methods used for customization.

Settings Data Copy Function (Functionality is expanded when connected to the XC-G control box. Refer to the XC-G technical documentation for further details.)

The control panel can be used to read the machine control box settings data and write to another control box.

Reading Settings Data (Control Box → Control Panel)

- (1) Turn ON the power while pressing the key. The display will indicate .
- (2) Turn the key ON to copy the settings data from the control box to the control panel.
- (3) Copying is completed successfully if the normal display appears after several tens of seconds. If M5 () displays, an error has occurred. Use the following procedure to perform the operation again.
 - 1) Turn the power OFF. → 2) Turn OFF the M5 display.
 - 3) Inspect the connector connection. → 4) Repeat the operation from step 1.

Writing Settings Data (Control Panel → Control Box)

- (1) Turn ON the power while pressing the key. The display will indicate .
- (2) Turn the key ON to copy the settings data from the control panel to the control box.
- (3) Copying is completed successfully if the normal display appears after several tens of seconds. If M5 () displays, an error has occurred. Use the following procedure to perform the operation again.
 - 1) Turn the power OFF. → 2) Turn OFF the M5 display. → 3) Check the control box voltage/model.
 - 4) Inspect the connector connection. → 5) Repeat the operation from step 1.

Notes: 1. The settings data cannot be written if the voltage and model (control box model name) do not match. (M5 () displays.)
 2. Never disconnect the control panel while reading or writing settings data. Control box operation after disconnection cannot be guaranteed.

6. ERROR DISPLAY

The following error codes display at the stitch number display area in the unlikely case that an error occurs at the motor, control box or detector and so forth. Turn OFF the power switch after checking the error code and perform inspection according to Table 1. If the error persists, please contact your sales representative.

Table 1 : Error Codes and Inspection Details

Error Code	Inspection Details
/ POWER.OF	Check whether the power supply voltage is low, or the power supply capacity is insufficient. The same display appears when the power is turned OFF, however, this does not indicate a breakdown.
/ E1	Check whether the wiring to the motor has shorted, or the machine load torque is excessively large.
/ E3	Check that the motor and encoder connectors are properly connected. Also check to ensure that the machine is not locked.
/ E9	Check to ensure that the wiring to all solenoids (thread trim, presser foot lift etc.) is correct. Check to ensure that the coils for each solenoid have not shorted.
/ M5	This error occurred when copying from the control panel. Check that the control panel connector is properly connected. Check to ensure that the control box voltage and model (control box model name) match.

Refer to the technical information manual for XC-G or XC-K series for details of errors other than those above.

mitsubishi
MITSUBISHI ELECTRIC CORPORATION

TOKYO 100-8310, Japan

Printed in Japan