

JUKI®

INDUSTRIAL SEWING MACHINE

MODEL

PLK-J4040RH

TECHNICAL MANUAL

SEWING MACHINE HEAD

FOR SAFE USE

Before the installation, operation, and inspection for this product, read the “FOR SAFE USE” and the technical manuals carefully. Also read the other technical manuals, “Control Unit” and “Operation Panel” describing some instructions, which are not in this manual, and use the sewing machine properly.

SAFETY INDICATIONS

| | | |
|--|----------------|--|
| | DANGER | Indicates that incorrect handling may cause hazardous conditions, resulting in death or severe injury. |
| | CAUTION | Indicates that incorrect handling may cause hazardous conditions, resulting in medium or slight personal injury or physical damage. Note that CAUTION level may lead to a serious consequence according to the circumstances. Always follow the instructions of both levels because they are important to personal safety. |

CAUTION INDICATIONS

| No. | Caution indication | Description |
|-----|--------------------|--|
| 1 | | <p><u>Precaution for sewing machine operation:</u></p> <p>Indicates that removing the safety and operating the sewing machine for some other purposes with power-on are prohibited.</p> <ul style="list-style-type: none"> ● Please do not operate the sewing machine without protective equipment such as a needle guard, an eye guard, a belt cover or the others. ● Please turn off the power switch when threading, changing a needle and a bobbin, cleaning, and lubricating. |
| 2 | | <p><u>Caution for fingers injury:</u></p> <p>Indicates a possibility of fingers (hands) injury in a certain condition.</p> |
| 3 | | <p><u>Caution for squeezing fingers:</u></p> <p>Indicates a possibility of squeezing fingers in a certain condition.</p> |

SAFETY PRECAUTIONS



To prevent from receiving an electric shock, always turn off a power switch and unplug power supply when opening a control box, and then open after ten minutes passes.



USAGE ENVIRONMENT

Please do not operate the sewing machine under the following conditions.

- (1) In the ambient temperature of 35 degrees (95°F) or more than 35 degrees, or the ambient temperature of 5 degrees or less than 5 degrees (41°F).
- (2) In the ambient temperature of 55 degrees (131°F) or more than 55 degrees, or the ambient temperature of -10 degrees or less than -10 degrees (18°F) during transportation.
- (3) In the relative humidity exceeding 85% or less than 45%.
- (4) In the open-air place or the location that receives direct sunlight.
- (5) In the place near heat sources such as heating devices.
- (6) In the atmosphere filled with dust, explosive gas, or corrosive gas.
- (7) In the place where the fluctuation in the power voltage of 10% or more than 10%, or the power voltage of -10% or less than -10% of the fixed power voltage.
- (8) In the place where the power source cannot supply enough voltage to keep the motor running.
- (9) In the place filled with strong electric noises such as high-frequency welders.

INSTALLATION

- (1) Please have some specialists, who have enough experience for the sewing machine installations, install the sewing machine.
- (2) Please have a qualified electrician perform necessary electric wiring.
- (3) Please do not operate until the sewing machine is repaired when any damage or fault is found on the sewing machine at the installation.
- (4) Please do not refurbish the sewing machine.
- (5) The sewing machine is heavy. For the safety, please make sure to install the sewing machine head by more than one person.
- (6) Please make sure to fit the safety protective equipment (the motor cover or the others) and the accessory protective equipment (the eye guard) that removed temporarily for installation.

SEWING

- (1) Please make sure to turn the power switch off before installing or replacing needles.
- (2) Please pay attention for the fingers not to be injured by the needle point.
- (3) Please make sure to turn power switch off before lubricating.
- (4) Please pay attention that oil does not get on your skin or in your eyes as it may cause an inflammation.
- (5) Please make sure to keep oil out of the reach of children who may drink oil by mistake.
- (6) Please make sure to turn the power switch off before threading a needle.
- (7) Before starting the sewing, please make sure the position and the function of the halt switch.
- (8) Please do not touch the operating parts during sewing operation.
- (9) It is very dangerous to operate the sewing machine without safety guards (eye guards, belt covers, link covers, finger guards or the others).
Please make sure to operate the sewing machine with safety guards.
- (10) Please make sure to turn the power switch off when stopping the sewing machine temporarily.

ADJUSTMENT

- (1) Please make sure to turn the power switch off before adjusting the sewing machine.
- (2) If the adjustment is required while the power switch on, do not step on the foot switch by mistake.
- (3) Please be careful not to be injured by a sharp part such as the needle and the shuttle hook point.
- (4) Please make sure to put the safety guards (eye guards, belt guards, link covers, and finger guards or the others) back on the initial position after the sewing machine adjustment.

CONTENTS

| | |
|--|----|
| 1. STRUCTURE OF THE SEWING MACHINE | 1 |
| 2. SPECIFICATIONS | 2 |
| 3. INSTALLATION | 3 |
| 3-1. Installation of the foot switch | 3 |
| 3-2. Connection of the air tube | 4 |
| 3-3. Installation of the thread stand | 4 |
| 3-4. Installation of the eye guard | 5 |
| 3-5. Installation of the rubber cushion | 5 |
| 4. LUBRICATION | 6 |
| 4-1. Filling the oil tank | 6 |
| 5. PROPER OPERATION | 7 |
| 5-1. Installation of the needles | 7 |
| 5-2. Threading the needle thread | 8 |
| 5-3. Winding the bobbin thread | 9 |
| 5-4. How to opening the bobbin access door | 10 |
| 5-5. Setting the bobbin | 11 |
| 5-6. Setting the inner hook | 11 |
| 5-7. How to operating the jig eject system | 12 |
| 5-8. Operation of the halt switch | 13 |
| 5-9. Adjustment of the thread tension | 14 |
| 5-10. Adjustment of upper thread tension | 14 |
| 6. STANDARD ADJUSTMENT | 15 |
| 6-1. Adjustment of the needle bar position | 15 |
| 6-2. Adjustment of the position between the needle and the rotating hook | 16 |
| 6-2-1. Adjustment of the clearance between the hook point and the needle | 16 |
| 6-2-2. Adjustment of the main shaft detector | 18 |
| 6-2-3. Adjustment of the timing between hook and needle motion | 20 |
| 6-3. Adjustment of the hook positioner's position | 23 |
| 6-4. Adjustment of the oil lubrication | 24 |
| 6-5. Setting of the pressor foot movement | 25 |

| | |
|---|-----------|
| 6-6. Adjustment of the thread take up spring | 25 |
| 6-6-1. Adjusting movable range of the thread take up spring | 25 |
| 6-6-2. Adjusting intensity of the thread take up spring | 26 |
| 6-7 Adjustment of the air pressure | 26 |
| | |
| 7. VARIOS ADJUSTMENT | 27 |
| 7-1. How to exchanging the tension spring of the needle thread tensioner unit | 27 |
| 7-2. Adjustment of the detector position of the presser foot unit | 29 |
| 7-3. How to replace with a special pressor foot | 32 |
| 7-4. Adjustment of the pressor foot holder position | 35 |
| 7-5. Adjustment of the thread trimmer | 36 |
| 7-5-1. Adjustment of the movable knife | 36 |
| 7-5-2. Adjustment of the fixed knife | 37 |
| 7-5-3. Adjustment of the trimmer cam detector position | 38 |
| 7-6. How to remove the XY cover | 39 |
| 7-7. Adjustment of the XY table detector | 40 |
| 7-7-1. Adjustment of X direction | 41 |
| 7-7-2. Adjustment of Y direction | 42 |
| 7-8. Adjustment of the Y timing belt tension | 43 |
| | |
| 8. MAINTENANCE | 44 |
| 8-1. Cleaning | 44 |
| 8-2. Greasing | 44 |
| 8-3. Disposing of oil waste | 46 |
| | |
| 9. TROUBLESHOOTING | 47 |
| | |
| 10. APPENDIX | |
| 10-1. The positional relationship between the sewing area and jig eject system | |
| 10-2. Air piping drawing | |

1. STRUCTURE OF THE SEWING MACHINE

PLK-J4040RH industrial sewing machine consists of the following main parts.

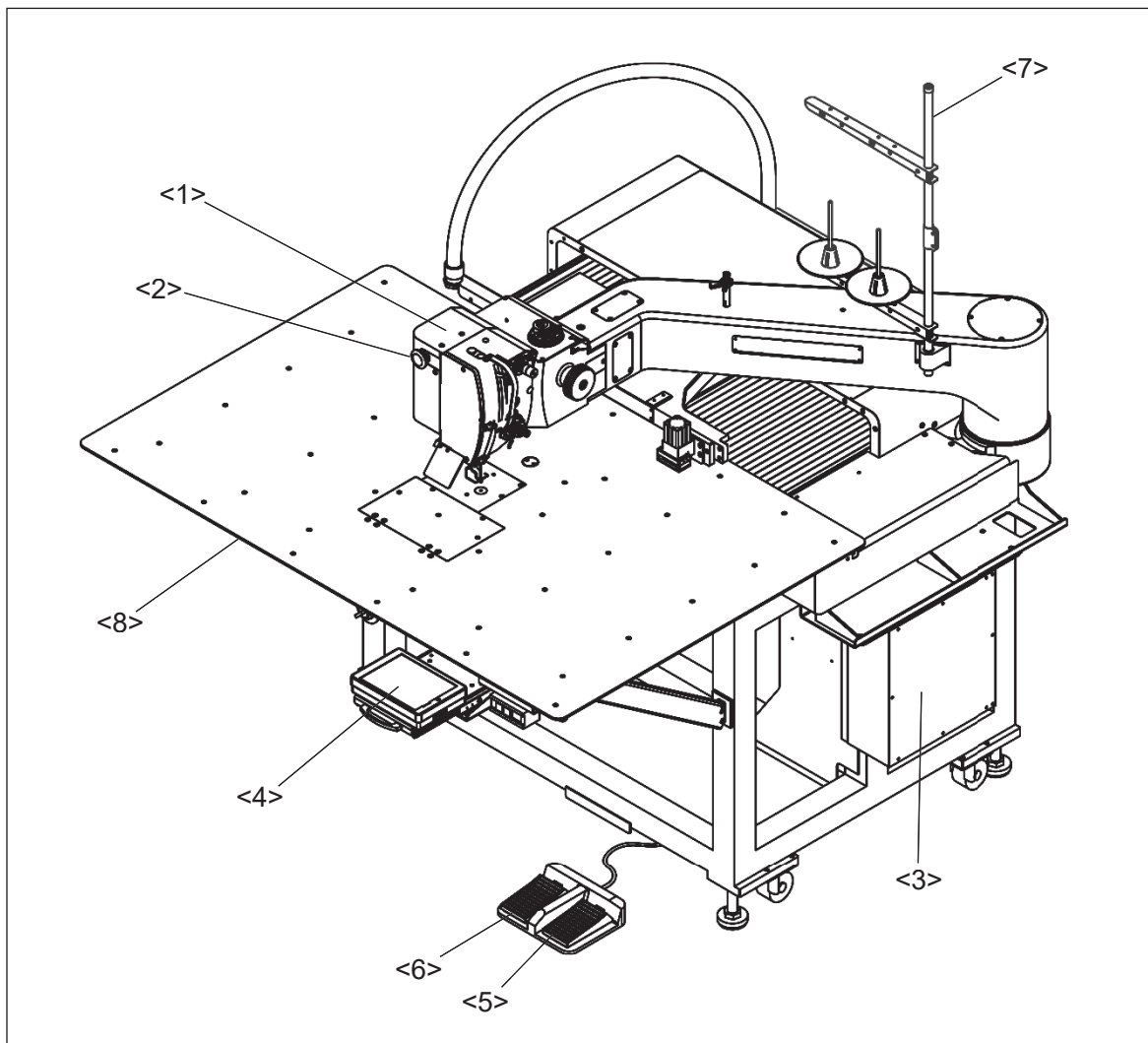

<1>: Sewing machine head <2>: Halt switch <3>: Control box <4>: Operation panel
<5>: Work holder switch <6>: Start switch <7>: Thread stand <8>: Sewing machine table

2. SPECIFICATIONS

| | |
|-----------------------------------|--|
| Model | PLK-J4040RH |
| Stitch type | Single needle lock stitch |
| Hook | Extra large size rotating hook |
| Class of needle | DDx1#26 |
| Sewing area | X-direction (left/right) 400 mm |
| | Y-direction (front / back) 400 mm |
| Maximum sewing speed *1 | 1,000rpm (Continuous feeding) 1,000rpm (M3 feeding) |
| Setting speed | 10 speed levels in 200 rpm to 1,000 rpm (M3 feeding) |
| Stitch length | 0.1 to 20.0 mm (min. resolution 0.1 mm) |
| Maximum number of needles | 20,000 per pattern |
| Storable sewing data item | 9,000 patterns *2 |
| Data memory | USB memory |
| Type of motor (Needle side) | 750W direct servo motor |
| Type of motor (Hook side) | 400W direct servo motor |
| Work holder | Jig eject system |
| Needle bar stroke | 50.8 mm |
| Thread take up lever stroke | 100 mm |
| Presser foot drive | Direct drive by stepping motor |
| Presser foot lift | 15.0 mm (max. 30.0 mm) Variable in 0.1 mm step |
| Presser foot stroke *3 | Digital adjustment stroke: 0.0 to 10.0 mm |
| Upper thread tensioner | Manual / automatic / Setting on pattern (switchover) |
| Oil lubrication | Spray method: Spray time adjustment |
| Operation panel | 6.5-inch color LCD touch panel with USB port |
| External device I/F | USB port, Terminal I/O: 16 input, 16 output |
| Thread trimmer system | Horizontal engagement with fixed knife and movable knife Only bobbin thread trimming *4 |
| Machine dimensions (W)x(L)x(H) | 1,350mm x 1,570mm x1,250mm |
| Weight | 460kg |
| Power | In 200V to 240V single-phase or three-phase |

*1: Sewing speed may be limited by the operation or sewing condition.

*2: The max. patterns may be limited depending on the number of stitches of each pattern in the memory.

*3: Standard value is 8.0 mm.

*4: This sewing machine cannot trim the needle thread.

3. INSTALLATION



- (1) Please have some specialists, who have enough experience for the sewing machine installations, install the sewing machine.
- (2) Please have a Qualified Electrician perform necessary electric wiring.
- (3) Please do not operate until the sewing machine is repaired when any damage or fault is found on the sewing machine at the installation.
- (4) Please do not refurbish the sewing machine.

3-1. Installation of the foot switch

Connect the foot switch to the connector CON L. The foot switch is enclosed in the accessory box.

NOTE Refer to the instructions in the paragraph "[4] Name of each part, wiring and grounding" in the **CONTROL UNIT** technical manual.

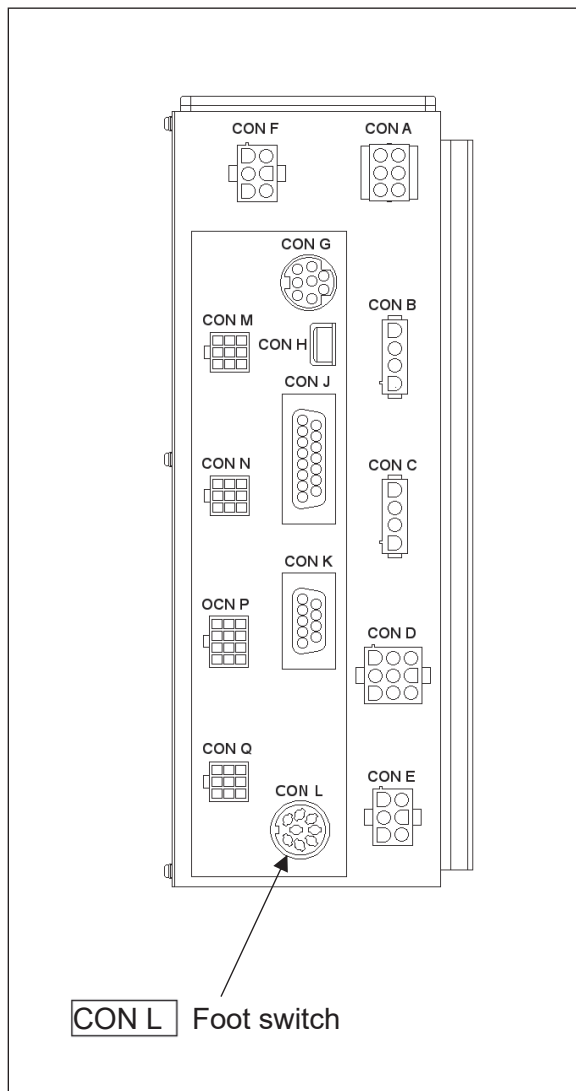

3-2. Connection of the air tube

Insert the one end of the air tube (8mm Diameter) into the intake air fitting (No.3) of the filter regulator (No.2) then, join the other end of the air tube with the suitable air coupling to be adopted with the air supply source provided in your factory. One of the air couplings (No.4) is enclosed in the accessory box.

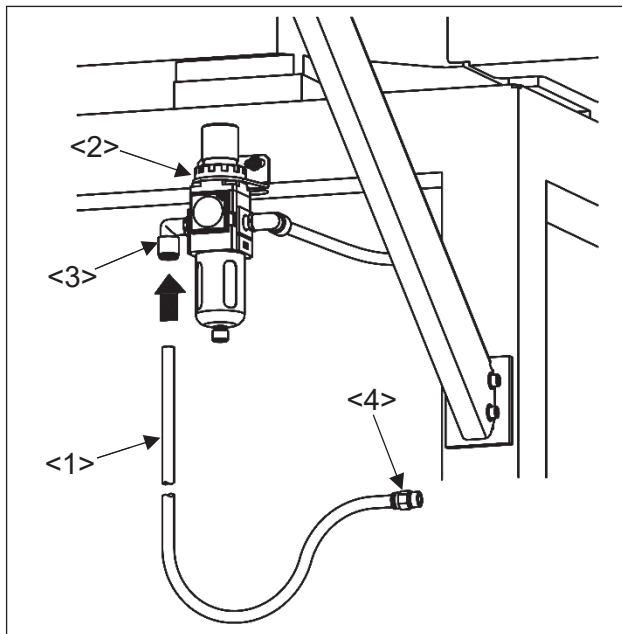

- <1>: Air tube (8mm Diameter)
- <2>: Filter regulator
- <3>: Intake air fitting
- <4>: Air coupling

3-3. Installation of the thread stand

(1) Assemble the parts of the thread stand as shown on the figure.

(2) Fit the thread stand into the hole at the far right on the machine arm with the nut (No.14) and the washer (No.12) and cushion (No.13).

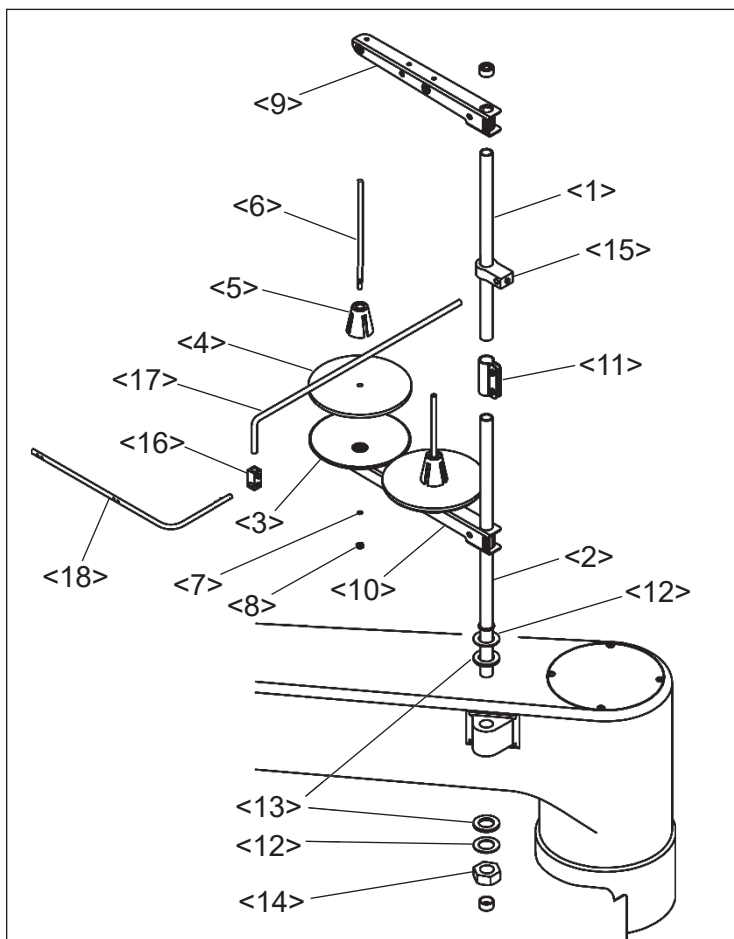

- <1>: Upper column pipe
- <2>: Lower column pipe
- <3>: Spool stand base
- <4>: Spool mat
- <5>: Spool holder
- <6>: Spool shaft
- <7>: Spring washer
- <8>: Nut
- <9>: Thread hunger
- <10>: Spool holder
- <11>: Column joint
- <12>: Washer
- <13>: Cushion
- <14>: Nut
- <15>: Bracket (large)
- <16>: Bracket (small)
- <17>: Holder
- <18>: Thread guide

3-4. Installation of the eye guard

(1) Mount the eye guard (No.1) with screw (No.2) to sewing machine head.

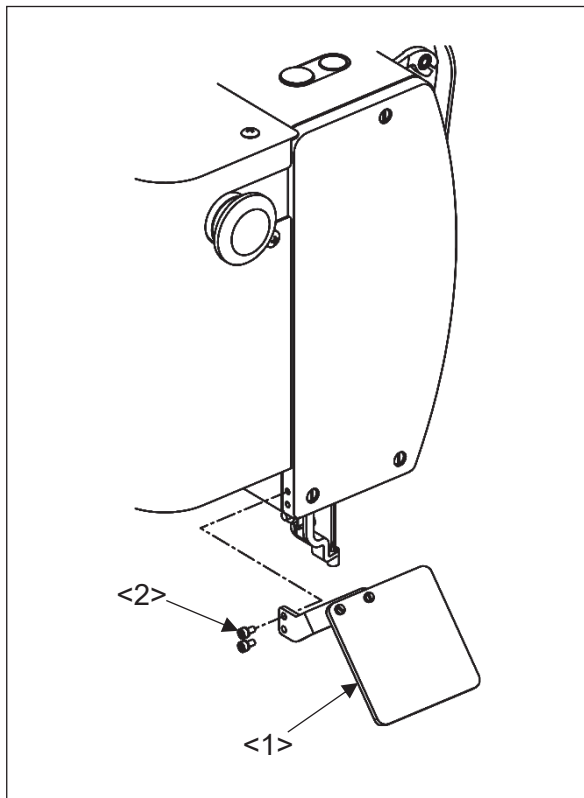

<1>: Eye guard unit

<2>: Screw

3-5. Installation of the rubber cushion

(1) Screw the adjust foot (No.2) in the direction of "a" arrow and locate the rubber cushion (No.1) between the adjust foot and floor which included in accessory box. For the other three rubber cushions, the procedure is same.

(2) Screw the adjust foot (No.2) in the direction of "b" arrow and adjust the adjust foot height so that the each hour caster (No.3) is to be raised from the floor by several millimeters. After adjustment please check if there is no inclination about the machine table.

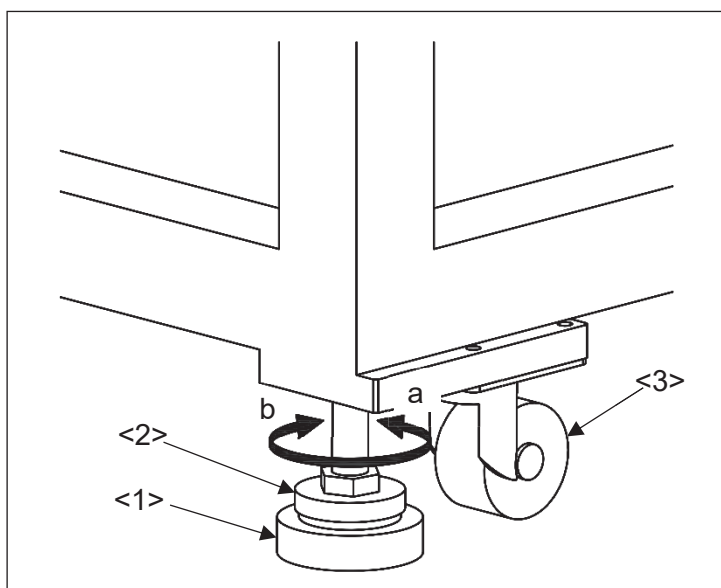

<1>: Rubber cushion

<2>: Adjust foot

<3>: Caster

4. LUBRICATION



CAUTION

- (1) Please make sure to turn power switch off before lubricating.
- (2) Please pay attention that oil does not get on your skin or in your eyes as it may cause an inflammation.
- (3) Please make sure to keep oil out of the reach of children who may drink oil by mistake.

NOTICE Please make sure to lubricate when operating for the first time after the installation. Also, please make sure to check the amount of oil when the machine has not been used for a long time.

4-1. Filling the oil tank

Pour the oil through the oil hole (No.1) to the oil tank (No.2) on the machine arm. Pour the oil through the oil hole (No.3) which has machine table to the oil tank (No.4). Please fill with the oil over level mark (No.5) of the oil tank.

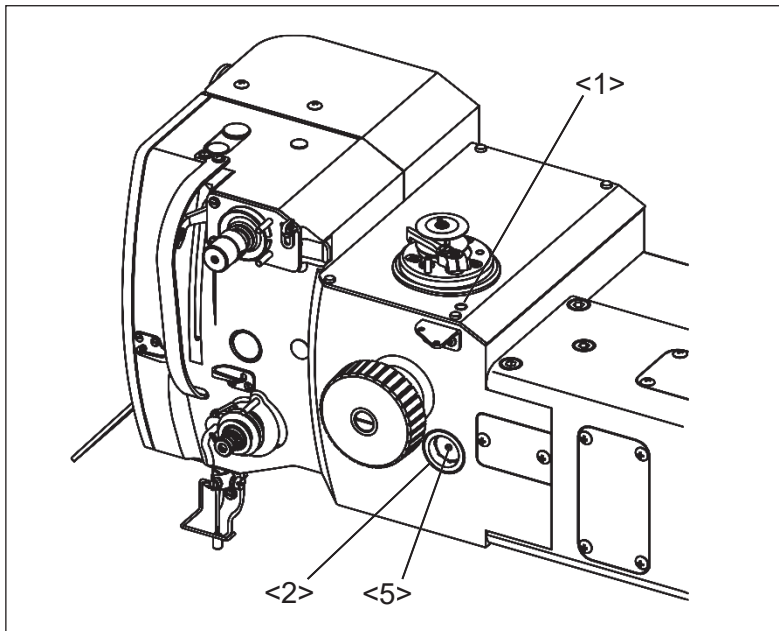

- <1>: Oil hole
- <2>: Oil tank
- <5>: Level mark

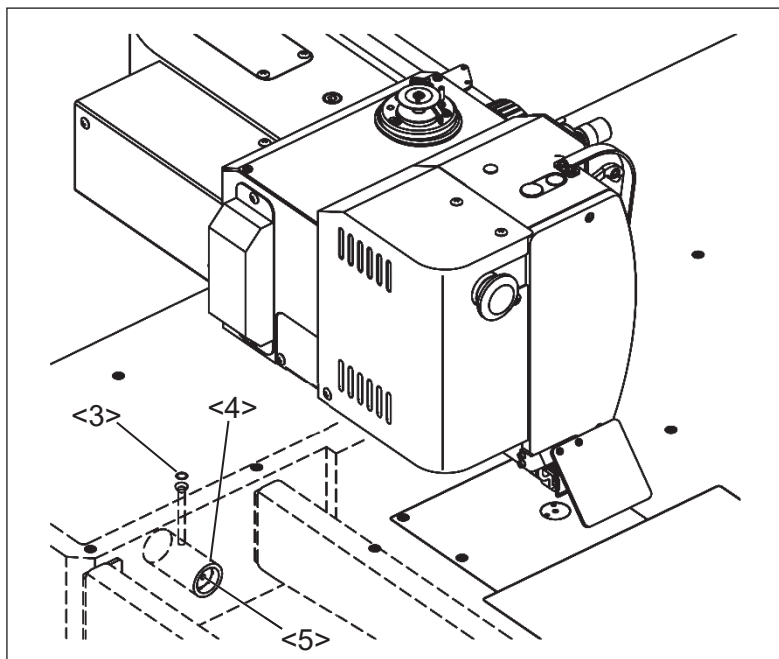

- <3>: Oil hole
- <4>: Oil tank
- <5>: Level mark

5. PROPER OPERATION

5-1. Installation of the needle



- (1) Please make sure to turn the power switch off before installing or replacing needles.
- (2) Please pay attention for the fingers not to be injured by the needle point.

- (1) Attach the needle holder (No.2) to the needle bar (No.1) then, insert a new needle (No.3) until the needle head is reached the end of the guide groove of the needle bar (No.1).
- (2) Tighten the set screw (No.5) with facing the needle groove (No.4) to the front.

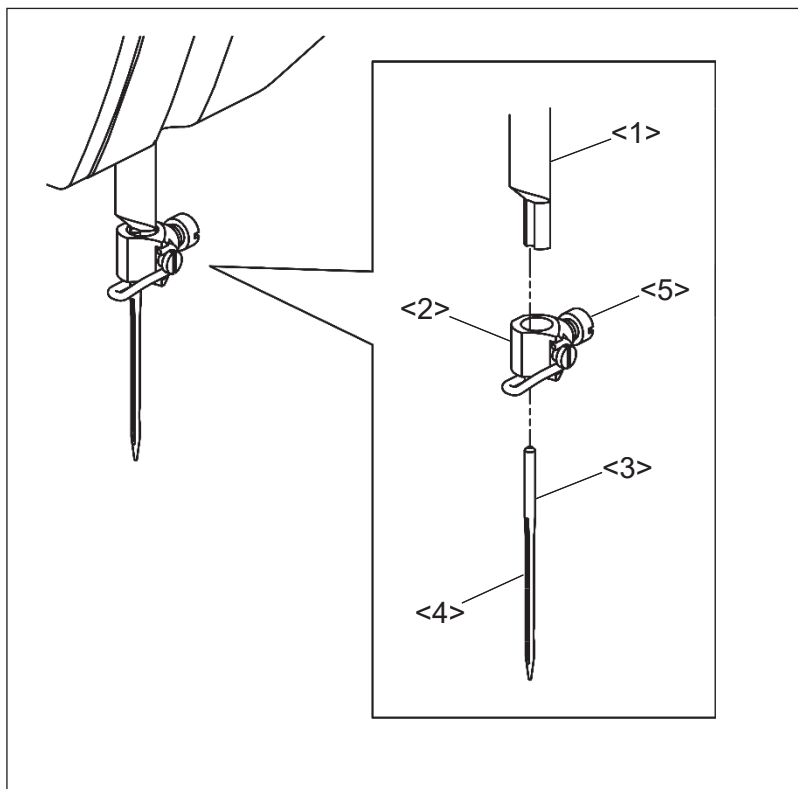

- <1>: Needle bar
- <2>: Needle holder
- <3>: Needle
- <4>: Needle groove
- <5>: Set screw

5-2. Threading the needle thread



(1) Please turn the power switch off when threading a needle.

(1) Thread the needle thread as shown on the figure.

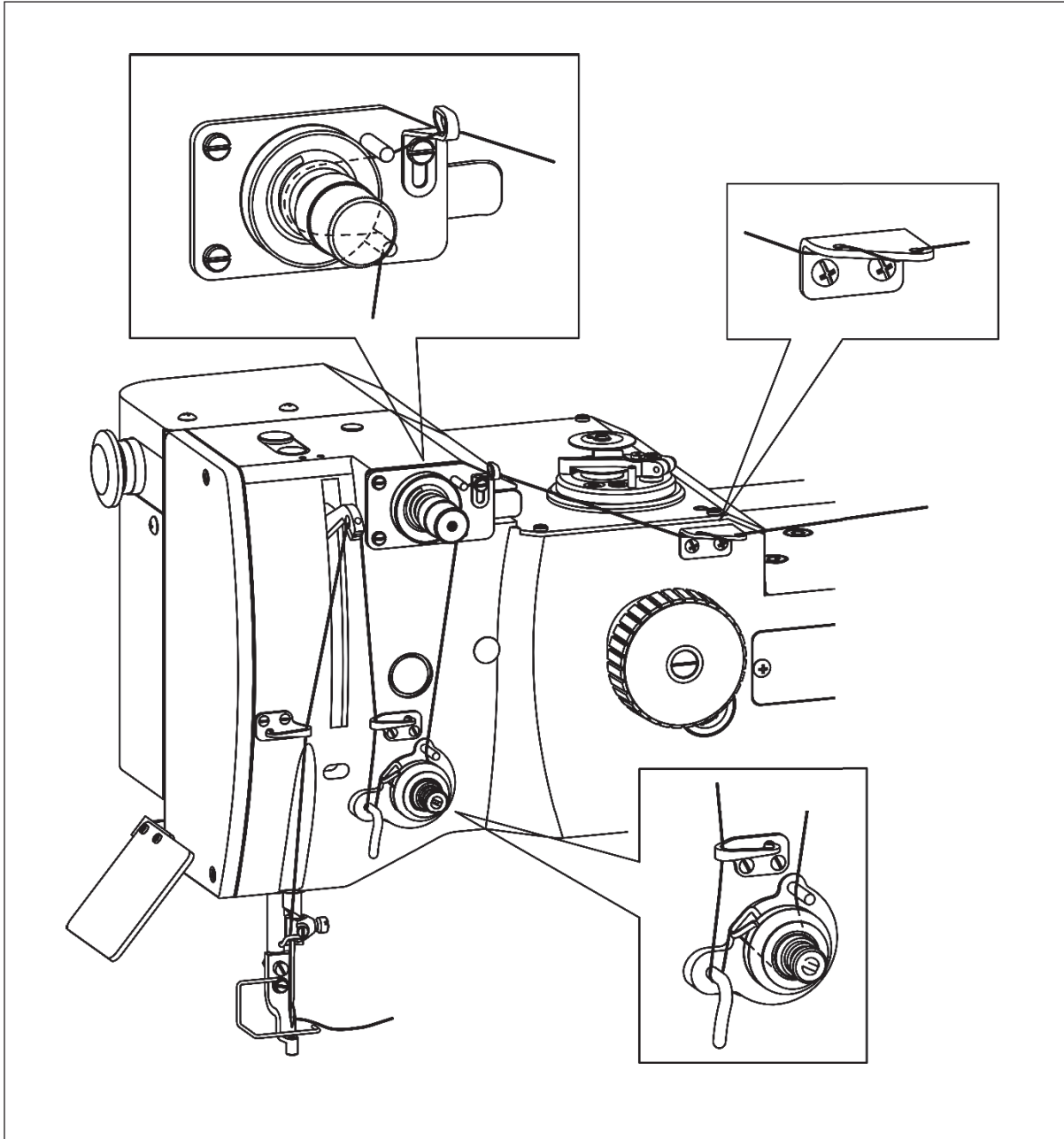

5-3. Winding the bobbin thread



(1) Please do not touch the rotating part during winding thread. Doing so may cause injury and/or the machine failure.

- (1) Fit the bobbin (No.1) to the bobbin winder (No.2). In this time, insert the pin (No.5) which has bobbin winder (No.2) to the hole of the bobbin (No.1).
- (2) Route the thread as shown in the below figure then, wind the thread to the bobbin (No.1) in the direction of "a" arrow several times and push the bobbin presser arm (No.3).
- (3) With the machine in the Bobbin Wind Mode, step on the work holder foot switch first and then the start switch second so that the thread continues winding to the bobbin while the start switch is stepped on.
- (4) When the bobbin finishes winding a certain amount (80 to 90 % of the outside diameter of bobbin) of thread, the bobbin presser arm is returned to the initial position. Adjust the amount of the winding thread with the subsidiary arm (No.4).
- (5) To wind the bobbin thread during the sewing operation, carry out the procedure (2) above then, the bobbin winding is performed automatically.

For the bobbin winding mode, refer to the instructions in the paragraph "[3] Explanations of basic screen, icons and operation "7. The Bobbin Winding screen" is explained below" in the

OPERATION PANEL technical manual.

NOTICE When winding in the bobbin winding screen please make sure to pull out the upper thread from the needle.

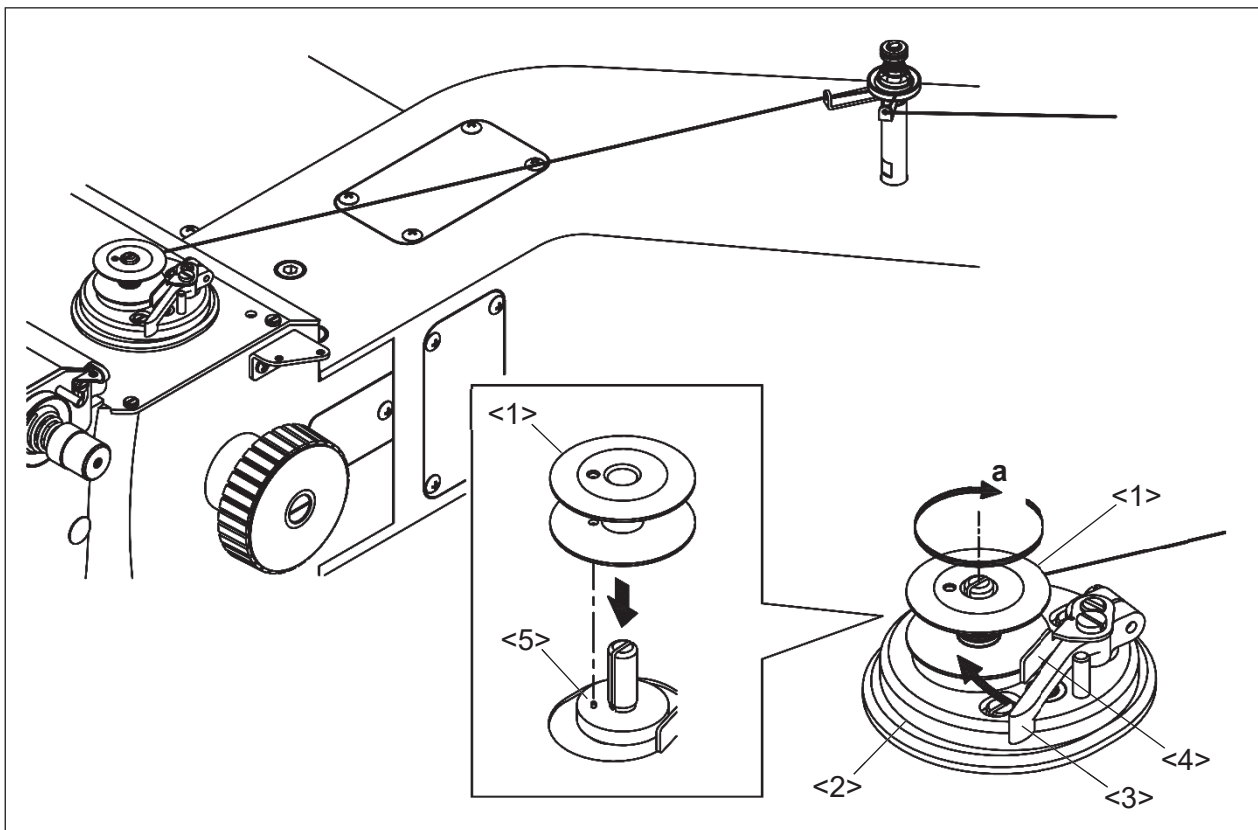

<1>: Bobbin <2>: Bobbin winder <3>: Bobbin presser arm <4>: Subsidiary arm <5>: Pin

5-4.How to opening the bobbin access door

When exchanging the bobbin, please open the bobbin access door (No.1) referring the following paragraph.
The bobbin access door has center of the machine table.

(1) Turn the opening switch (No.2) in the direction of the arrow which has front lower side of the table. The bobbin access door opens when opening switch (No.2) becomes state in showing in below figure.

(2) When closing the bobbin access door (No.1), turn the opening switch (No.2) in the opposite direction from state in .

NOTE When start the sewing unless the bobbin access door (No.1) is opened, the start prohibition signal is valid.

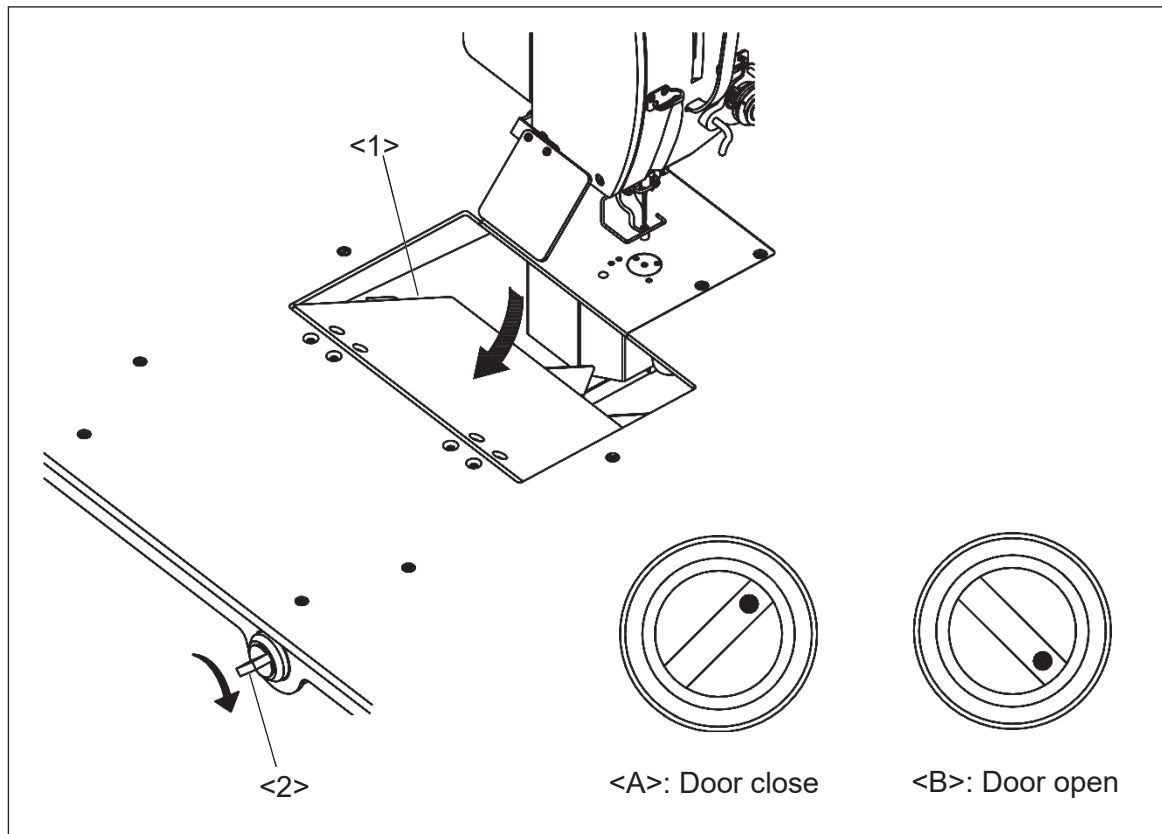

<1>: Bobbin access door <2>: Opening switch

5-5. Setting the bobbin

- (1) Insert the bobbin (No.2) to the inner hook (No.1).
- (2) Close the inner hook latch (No.3) and set the bobbin (No.2).
- (3) Pull the bobbin thread (No.4) into the slit (No.5) and pass through the thread hole (No.6).
- (4) Pull the bobbin thread (No.4) then, check with the bobbin (No.2) if it is rotated to the arrow direction. If it is not, set the bobbin (No.2) into the inner hook (No.1) over again to get the proper rotation.

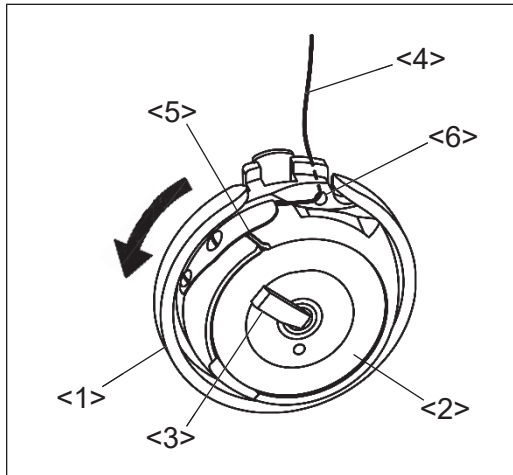

- <1>: Inner hook
- <2>: Bobbin
- <3>: Inner hook latch
- <4>: Bobbin thread
- <5>: Slit
- <6>: Thread hole

5-6. Setting the Inner hook

- (1) Pull the bobbin thread about 30 mm out of the thread hole of the inner hook (No.1).
- (2) Open the bobbin access door.
- (3) Open the hook holding arm (No.2) in the arrow direction.
- (4) By Inserting the top of inner hook (No.1) between the hook positioner (No.3) and hook (No.4), set the inner hook (No.1) securely.
- (5) Close the hook holding arm (No.2) for preventing come-off the inner hook (No.1).

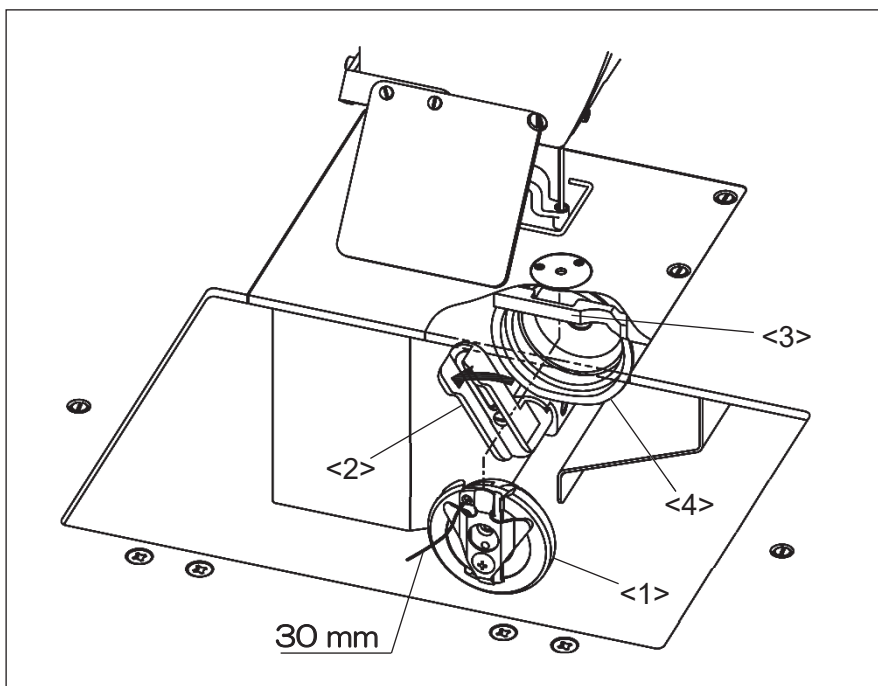

- <1>: Inner hook
- <2>: Hook holding arm
- <3>: Hook positioner
- <4>: Hook

5-7.How to operating the jig eject system

(1) Prepare the type of the work holder for jig eject system, and install the cassette jig right (No.1) and cassette jig left (No.2) which are enclosed in accessory box.

NOTE For more information concerning about dimension, please refer to the last chapter <10-1.>.

(2) Install the cassette jig right (No.1) and cassette jig left (No.2) to the inmost part of the each jig eject system (No.3).

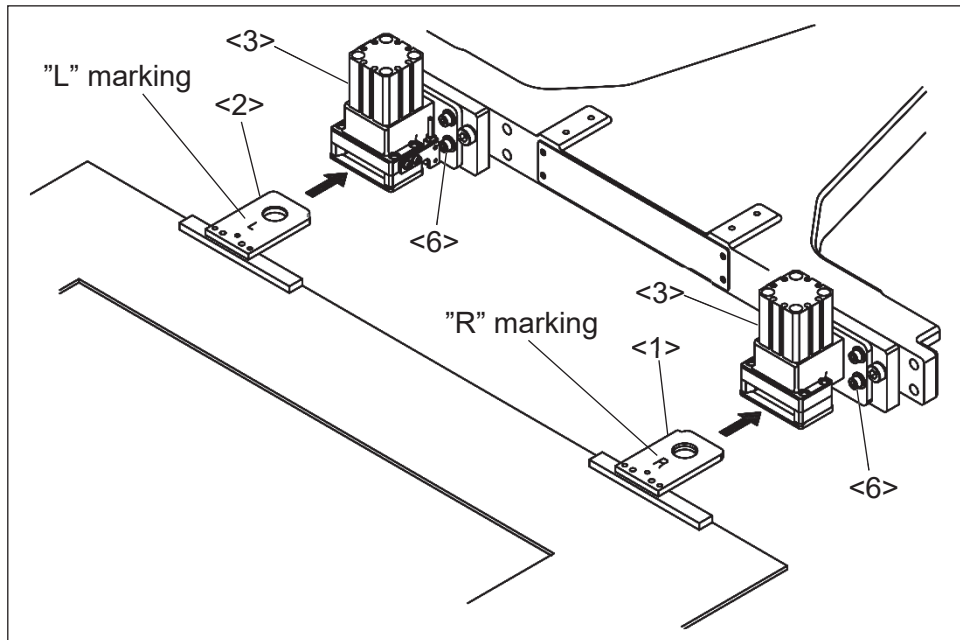

<1>: Cassette jig right <2>: Cassette jig left <3>: Jig eject system
 <6>: Jig eject system install screw

(3) Step on the work holder (black colored) foot pedal. The work holder become fixed when both of locate pin (No.4) which has each jig eject system actuated. Please make sure if the work holder is fixed securely after step on the foot pedal. The work holder is not fixed due to the insufficient actuation of locate pin (No.4) when either or both cassette jig are not installed enough.

NOTE Please make sure if the bottom surface of cassette jig (A) and lower plate (No.5) are in same level. If different, loosen the each four of Jig eject system install screws (No.6) and adjust the jig eject system (No.3) height.

NOTICE Please note that the lower plate (No.5) does not touch directly to the slide plate.

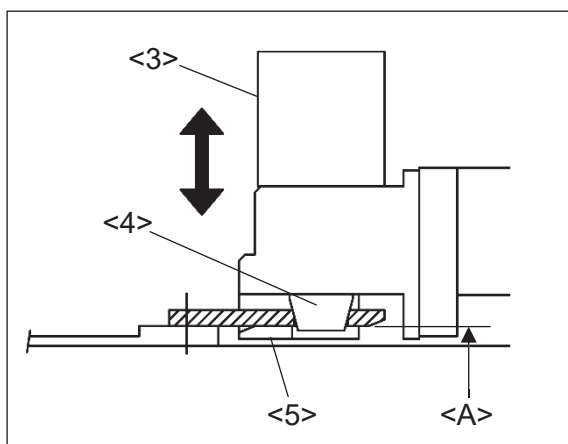

<3>: Jig eject system
 <4>: Locate pin
 <5>: Lower plate
 <A>: Bottom surface of cassette jig

5-8. Operation of the halt switch

- (1) If accidents such as a thread breakage, needle breakage and others happened during the sewing, press the halt switch immediately. The sewing machine stops instantly.
- (2) To cancel the halt state, press the halt switch again.
- (3) When continuing sewing, step on the grey foot switch to restart at the halted position. (Press the jogging in forward/reverse direction icon so that the sewing start position will move.)
- (4) To cancel sewing, press the home position return icon .

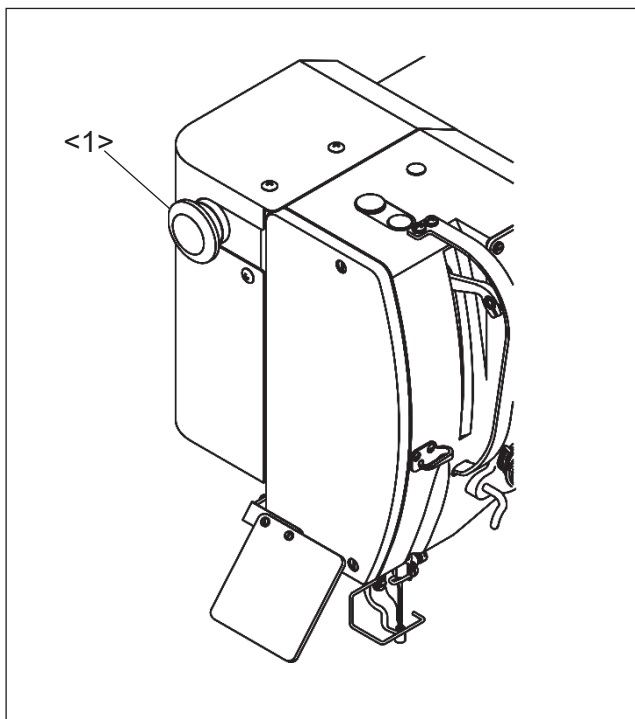

<1>: Halt switch

5-9. Adjustment of the thread tension

(1) Adjust the bobbin thread tension with the thread tension adjusting screw (No.2) on the inner hook (No.1). The thread tension become loose if turn the thread tension adjusting screw (No.2) to the counterclockwise, and the thread tension becomes tight if turn it to the clockwise.

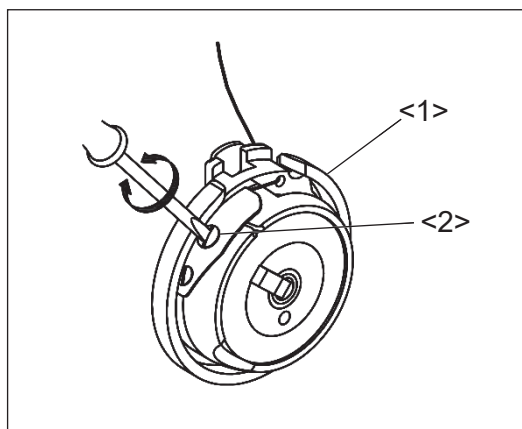

<1>: Inner hook
<2>: Adjusting screw

5-10. Adjustment of upper thread tension

Adjust the upper thread tension corresponding to the bobbin thread tension. The upper thread tension becomes tight when tightening the thread tension adjusting nut (No.1) clockwise, and the upper thread tension becomes loose when loosening the thread tension adjusting nut counterclockwise.

NOTE It is possible to adjust the upper thread tension automatically. Please refer to the instructions **OPERATION PANEL** technical manual concerning about [Digital tension].

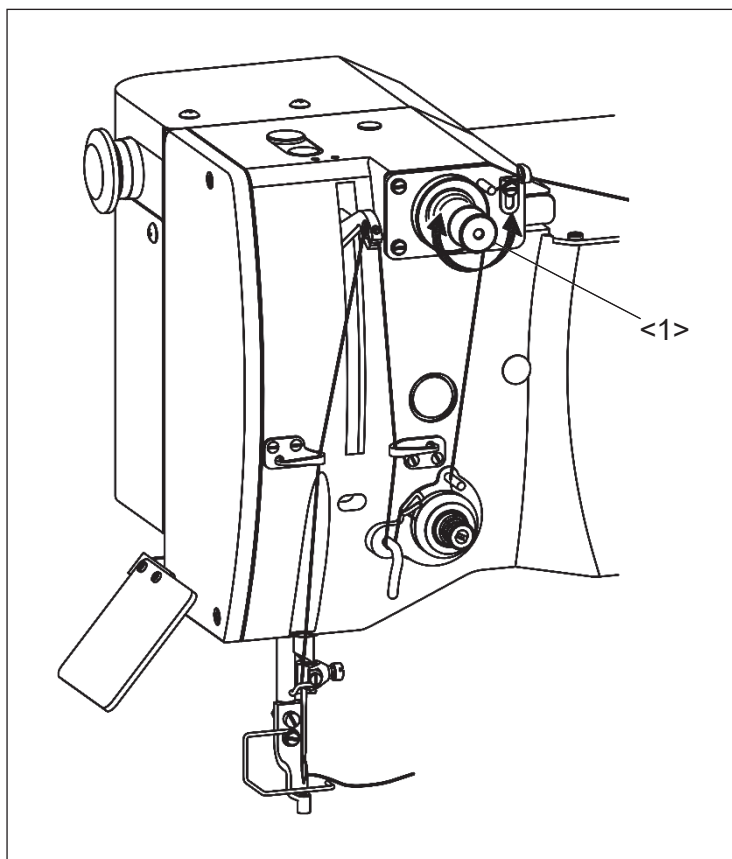

<1>: Thread tension adjusting nut

6. STANDARD ADJUSTMENT



CAUTION

- (1) Please make sure to turn the power switch off before adjusting the sewing machine.
- (2) When adjusting the sewing machine with the power switch on, please be careful not to step on the foot switch by mistake.
- (3) Please be careful not to be injured by a sharp part such as the needle and the hook point.
- (4) Please make sure to put the safety guards (eye guards, link covers, and finger guards or the others) back on the initial position after the sewing machine adjustment.

6-1. Adjustment of the needle bar position

- (1) Turn the power switch off then, remove the presser foot attaching screw (No.1) and nut (No.2) and remove the presser foot (No.3).
- (2) Turn the hand pulley (No.4) by hand in the direction of arrow and stop the needle bar (No.5) at the lowest position.

NOTE The needle shaft and the hook shaft are controlled by synchronous operation only when the power switch is on. In this reason, there is a risk that the needle may collide with hook when down the needle bar without removing the needle.

- (3) Make sure the clearance between the bottom of needle bar (No.5) and top of the needle plate is 23.5 mm.
- (4) If it is not correct, remove the face cover and eye guard then loosen the two of needle bar holder set screw (No.7) and adjust the needle bar position. For removing the face cover and eye guard, please refer to the paragraph [7-2. Adjustment of the detector position of the presser foot unit]

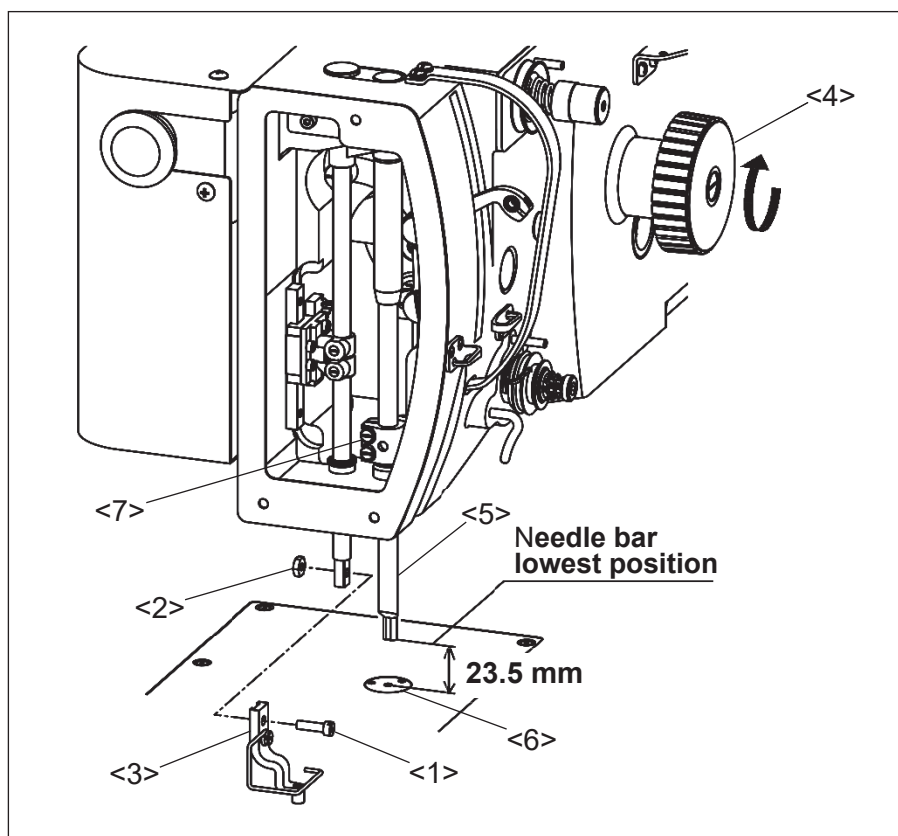

- <1>: Presser foot attaching screw
- <2>: Nut
- <3>: Presser foot
- <4>: Hand pulley
- <5>: Needle bar
- <6>: Needle plate
- <7>: Needle bar holder set screw

6-2. Adjustment of the position between the needle and the rotating hook

6-2-1. Adjustment of the clearance between the hook point and the needle

(1) Turn the power switch OFF.

(2) Open the bobbin access door.

(3) Remove the four screws (No.2) and remove the sliding plate (No.1). In this time, the trimmer link (No.4) is removed from the driving lever (No.3).

NOTE The trimmer lever (No.4) is fitted with drive lever (No.3) by entering the locate pin with have driving lever (No.3) into the trimmer lever (No.4) hole. When remove the trimmer lever (No.4), hold the trimmer lever (No.4) by hand as in the below drawing and lift the sliding plate (No.1). The trimmer link (No.4) is removed from the driving lever (No.3) smoothly.

(4) To entering the locate pin with have driving lever (No.3) into the trimmer lever (No.4) hole smoothly, aligning the center of the trimmer link (No.4) hole with the reference hole (No.5) when back the sliding plate (No.1).

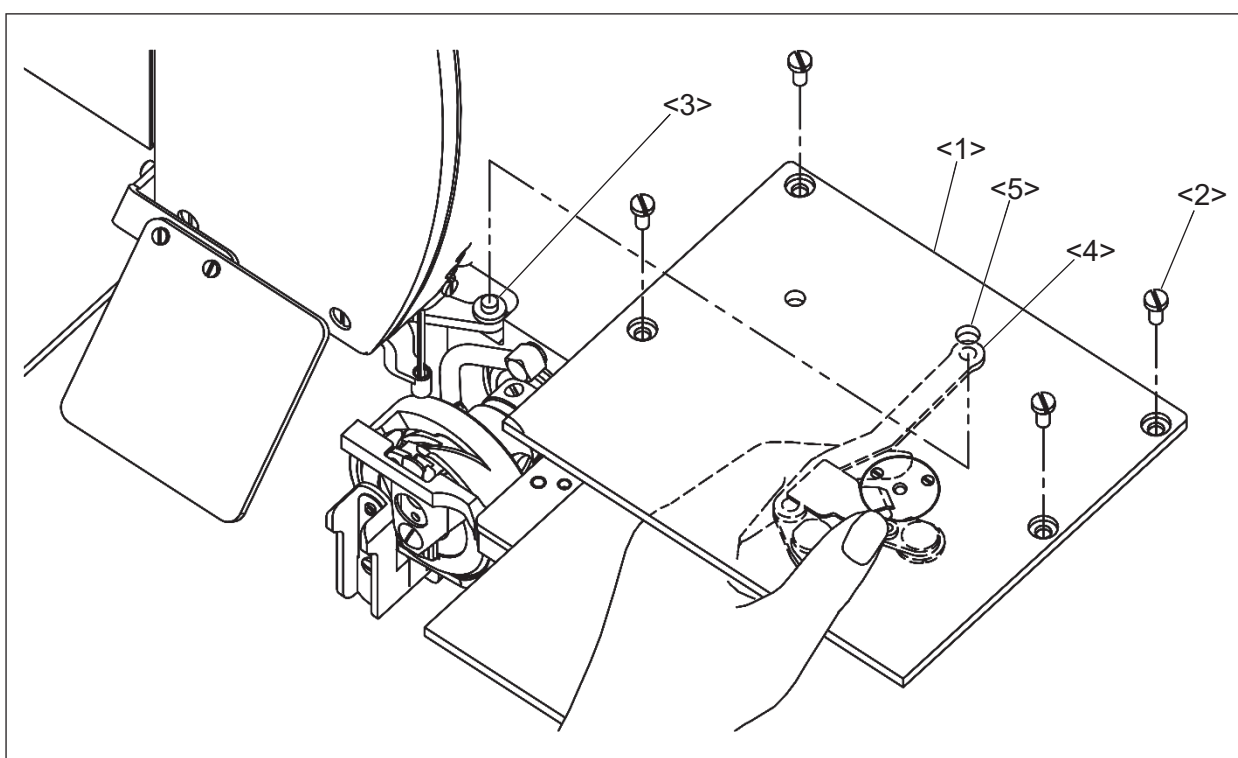

<1>: Sliding plate <2>: Screw <3>: Driving lever <4>: Trimmer lever
<5>: Reference hole

- (5) Turn the hand pulley and stop it at the position where the needle bar lifted 4.5 mm from its lowest position.
 (6) Turn the hook by hand and stop it at the position where the hook point (No.6) meets with the center line of the needle (No.7).

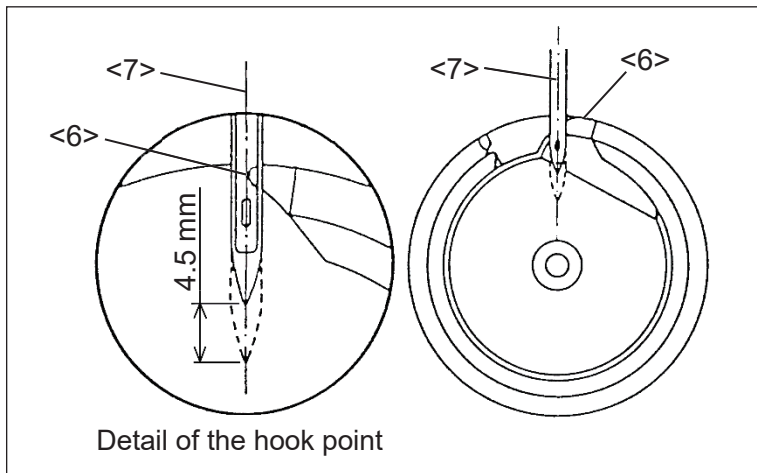

<6>: Hook point
 <7>: Needle

- (7) Loosen the three of the hook set screw (No.9) then, move the hook by hand and adjust the clearance between the hook point and the needle to be about 0.05 mm.

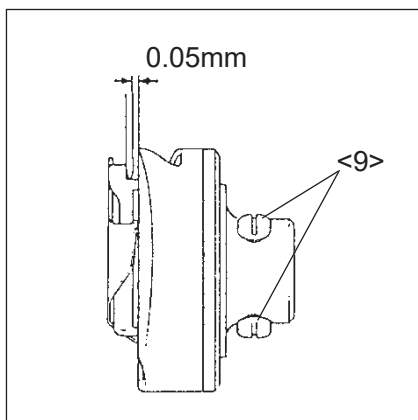

<9>: Hook set screw

- (8) Hold the hook and tighten the three of hook set screws (No.9) securely.

6-2-2. Adjustment of the main shaft detector

The main shaft detectors original position has to be adjusted when the state of needle bar upper position. When remove the parts of main shaft detector component, please adjust the main shaft detector position according to the following procedures.

- (1) Remove the two screws (No.6) and remove the detector cover (No.5).
- (2) Insert the hexagon wrench from the detector cover (No.5) opening and loosen the set screw (No.3) which has detector plate (No.2).

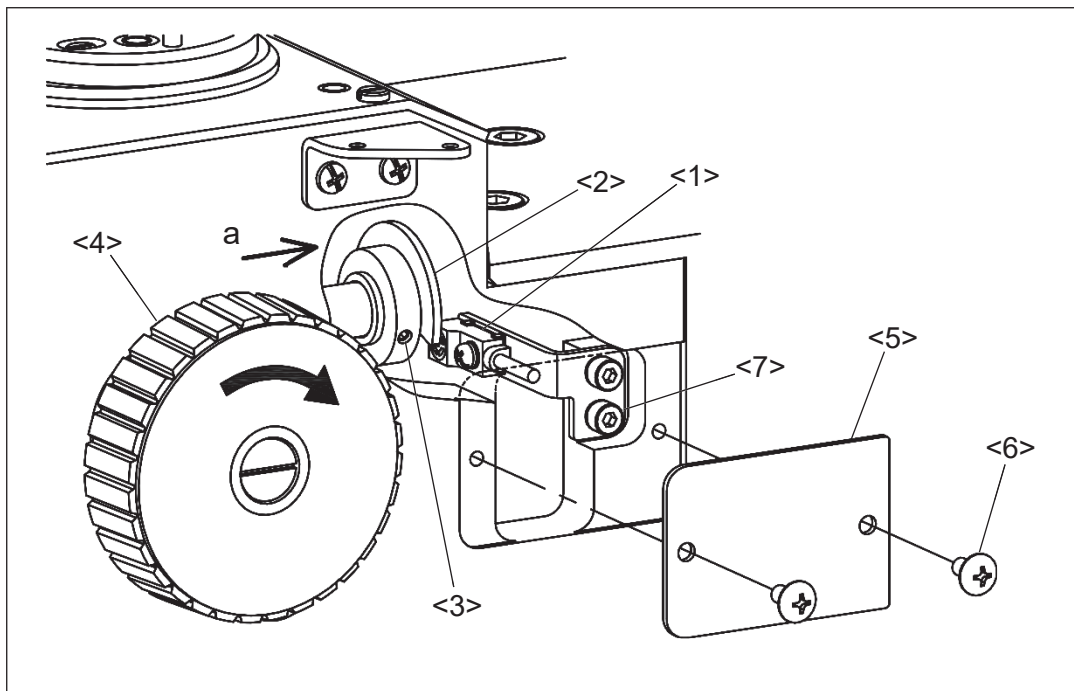

<1>: Main shaft detector <2>: Detector plate <3>: Set screw <4>: Hand pulley
<5>: Detector cover <6>: Screw <7>: Detector attaching screw

- (3) Remove the all of any parts, tools and screws on the sliding table. After make sure the work environment safety, Turn the power switch on. At this time, do not press the home position return icon .

- (4) After removing the face cover, turn the hand pulley (No.4) and stop it to the position where the needle bar upper position. In this state, the crank rod of needle bar (No.9) becomes vertical.

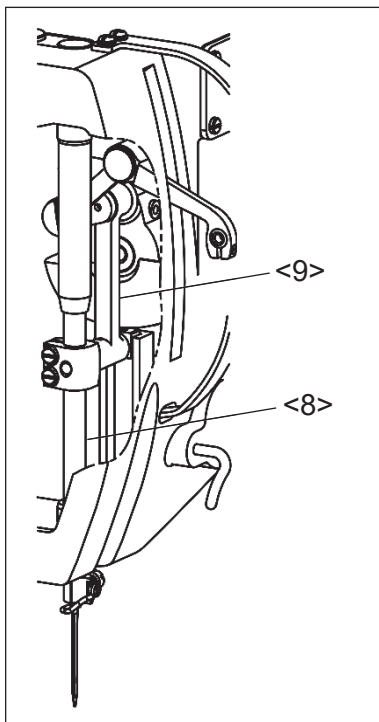

<8>: Needle bar
<9>: Crank rod of needle bar

- (5) Confirm the clearance between main shaft detector (No.1) and detector plate (No.2) is in the range of 1 to 1.5 mm. If it is not correct, loosen the detector attaching screw (No.7) and adjust the clearance.
- (6) Keep the needle bar position upper and move only the detector plate (No.2) little by little in the direction of arrow from the state of <A> as showing in below drawing. Stop the detector plate (No.2) and tighten the screw (No.3) at the position where the detection lamp lighted which has main shaft detector (No.1). In this state, the detector plate (No.2) is in the state of .

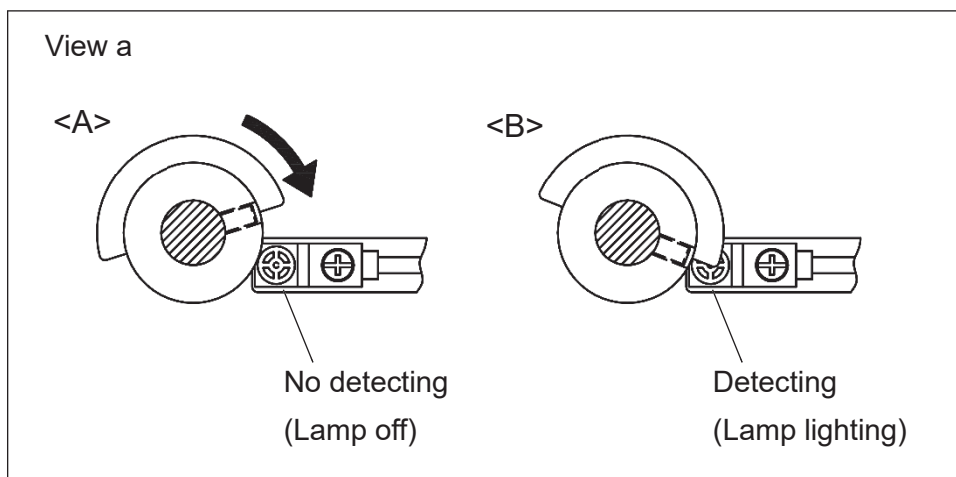

- (7) After adjustment, attach the detector cover and continue the adjustment according to the next paragraph [6-2-3. Adjustment of the timing between the hook and the needle motion].

6-2-3. Adjustment of the timing between the hook and the needle motion

The timing between hook and needle motion can be adjusted by operation panel. Please refer to the **OPERATION PANEL** technical manual if needed.

NOTE From the first home position returning after turn on the power switch, the hook and needle timing information is stored. This timing information cannot be overwritten when the power switch turned on. In this reason, please operate this adjustment before press the home position return icon.

(1) Press the  icon from the function mode.

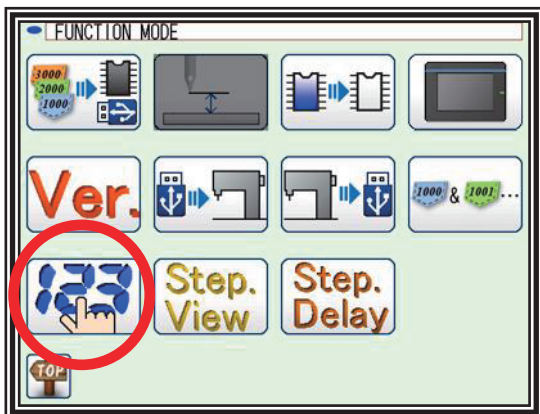



(2) Input the pass word, and press the  icon.

NOTE If press the home position return icon, the  icon is displayed with shading  and

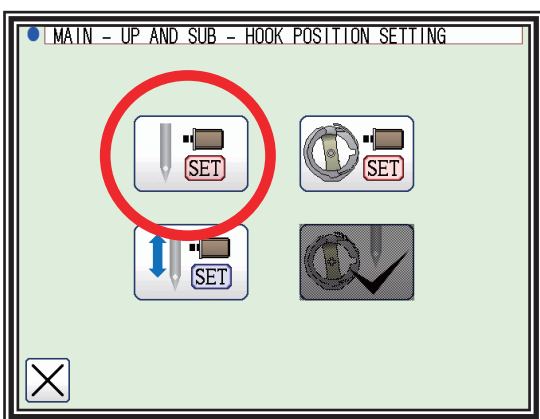
(3) Press the main motor up position setting icon.



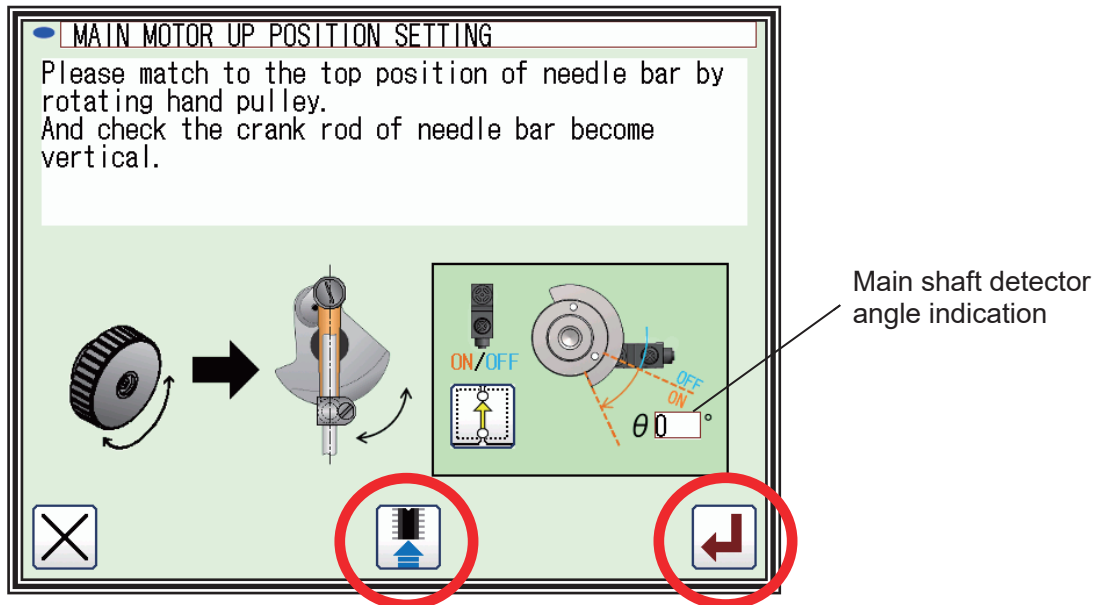

(4) Turn the hand pulley and match the main shaft detector angle indication to zero from main motor up position setting screen. In this position the needle bar becomes up position. After the completion of setting, press the  icon and then press the  icon.

NOTE The angle indication becomes zero degree when the main shaft detector detect the detector plate. For the adjustment of the main shaft detector see the previous paragraph [6-2-2.].



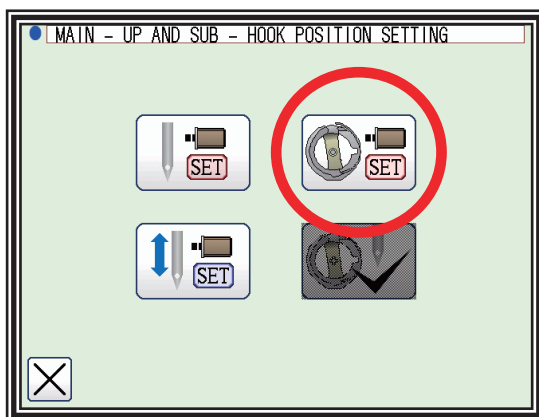

(5) Press the sub motor hook position setting icon.

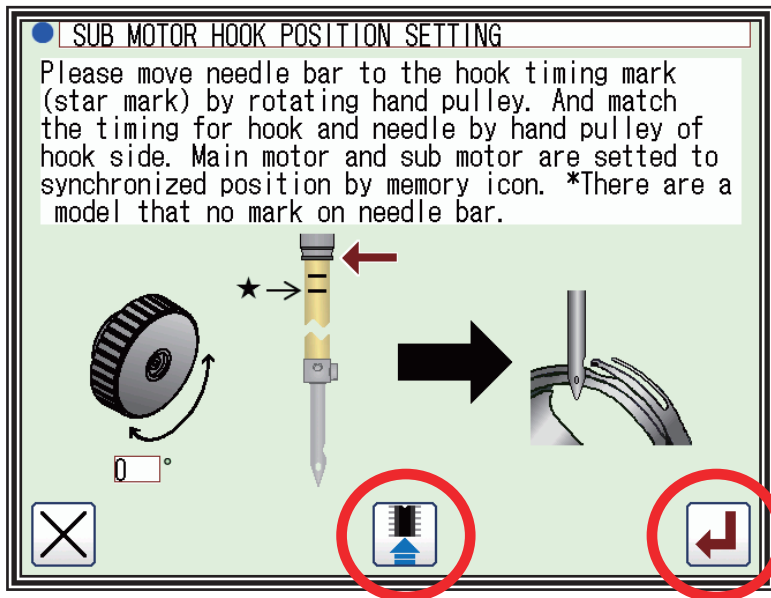

(6) Turn the hand pulley and stop it at the position where the needle bar lifted 4.5 mm from its lowest position. Turn the hook by hand and stop it at the position where the hook point meets with the center line of the needle. After the completion of setting, press the  icon and then press the  icon.

NOTICE The needle bar of this sewing machine does not have timing mark. Please refer to above description when setting the needle bar position.



(7) Press the home position return icon . After completing the origin return operation, press the  on the standard screen. Turn the hand pulley by hand and make sure the timing between hook and needle motion is performed sufficiently as described above.

(8) After adjustment turn the power switch off.

(9) After adjustment, put the sliding plate and bobbin case to the original locations and close the bobbin access door.

(10) When put the sliding plate back on the sewing machine, in order for the needle (No.1) to come into the right center of the needle hole of the needle plate (No.2), make sure that the needle plate hole center matches with the needle point then, tighten the set screws.

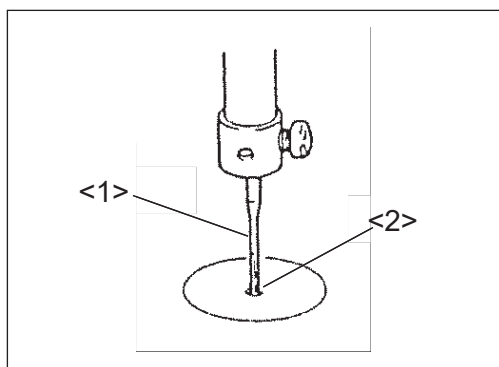

<1>: Needle

<2>: Center of the needle hole

6-3. Adjustment of the hook positioner's position

- (1) Remove the sliding plate.
- (2) Turn the inner hook by hand in the direction of arrow and contact to the "A" part of hook positioner.
- (3) In this time, confirm if the needle (No.3) is not contact with the "B" part of the inner hook opening (No.4) shown on the figure.
- (4) If the adjustment is necessary, loosen the hook positioner set screw (No.5) and adjust the hook positioner (No.1) position.
- (5) After the adjustment, put the sliding plate back on the sewing machine.

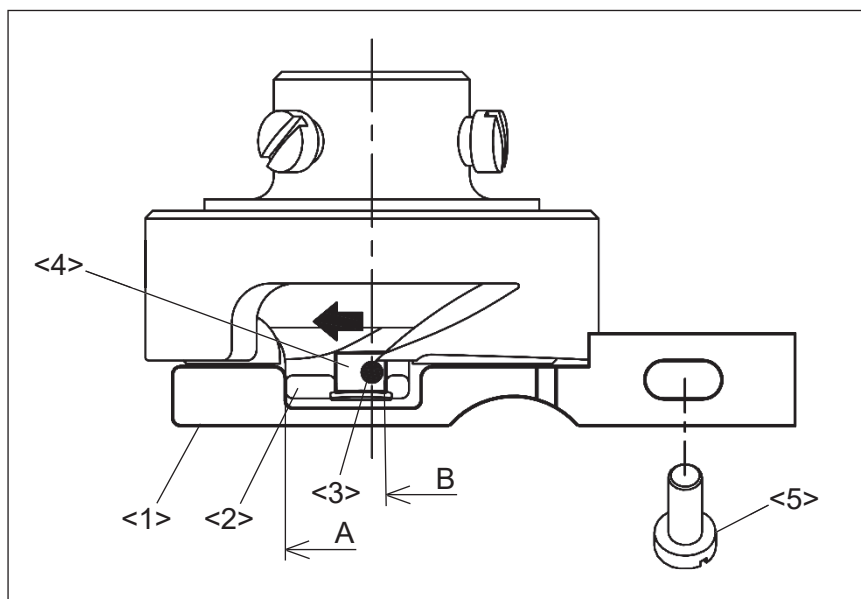

NOTE When put the sliding plate back on the sewing machine, in order for the needle to come into the right center of the needle hole of the needle plate, make sure that the needle plate hole center matches with the needle point. Refer to the previous paragraph [6-2-3 (10)].



- <1>: Hook positioner <2>: Inner hook <3>: Needle <4>: Inner hook opening
<5>: Hook positioner set screw

6-4. Adjustment of the oil lubrication

(1) Amount of oil supply is controlled by specified injection time for every specified stitch number. The lubrication oil is injected by compressed air.

Press the  on the standard screen, and press the  icon.

Select the  icon and enter the setting mode.

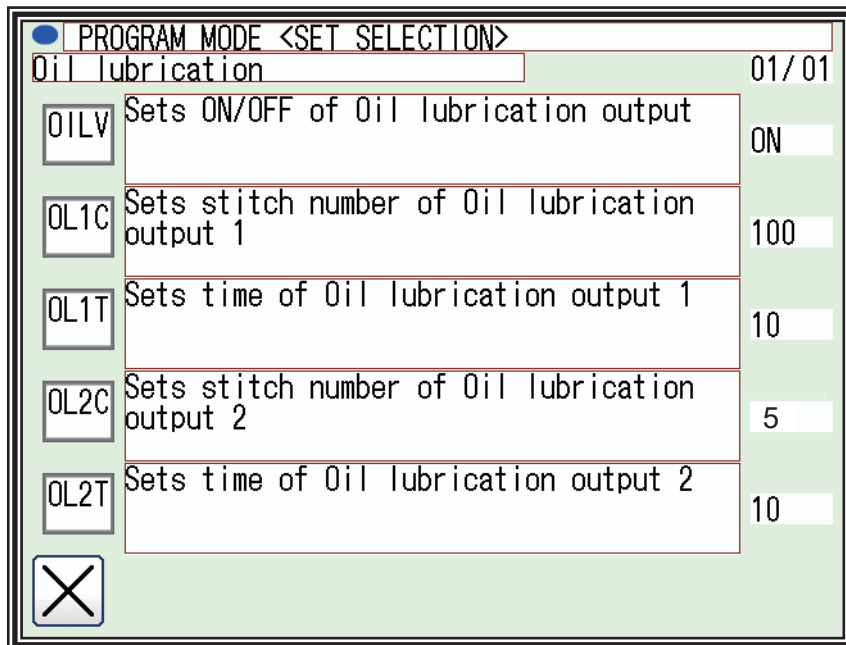

O1C: Setting of the machine head oil injection timing for every stitch number.

O1T: Setting of the machine head oil injection time.

O2C: Setting of the rotating hook oil injection timing for every stitch number.

O2T: Setting of the rotating hook oil injection time.

Default oil injection setting is described below.



Machine head: one second for every ten thousand stitches.



Rotating hook: one second for every five hundred stitches.

NOTE1 Please adjust the oiling amount for each sewing condition. For example, increase the (O1C,O2C) value or shorten the oil injection time (O1T, O2T) when much oil is consumed. However it is necessary to note the machine seizing when limit the oiling amount.

NOTE2 When shorten the oil injection time (O1T, O2T), set the value to 3-5 as a guide.

(2) It is also possible to lubricate once at the sewing start, instead of setting the oil injection timing for every stitch number (O1C, O2C). Please change the set value as following.

Press the  on the standard screen, and press the  icon.

Select the  >  > ST [Valid the oil lubrication output at start of sewing] in order. However, oil consume may increase when use this function. In this case, shorten the oil injection time (O1T, O2T).

6-5. Setting of the presser foot movement

It is not necessary to adjust the presser foot movement with operating the mechanical unit. Please refer to the instructions **OPERATION PANEL** technical manual and change each setting in matching with the sewing conditions.

(1) Adjustment of the presser foot height position:

Please refer to [9] Controlling the Presser Foot.

(2) Adjustment of the presser foot timing and stroke:

Please refer to [18] [Easy setting] 1-(3) [PF motion setting].

(3) Adjustment of the presser foot lift:

Please refer to [18] [Easy setting] 3-(2) [PF rising position adjustment].

6-6. Adjustment of the thread take up spring

6-6-1. Adjusting movable range of the thread take up spring

(1) To adjust the movable range of the thread take up spring (No.3) loosen the set screw (No.2) and turn the whole thread take up spring unit (No.1).

(2) Adjust the thread take up spring (No.3) stroke to be 18 mm, which is standard stroke.

(3) After adjustment tighten the set screw (No.2).

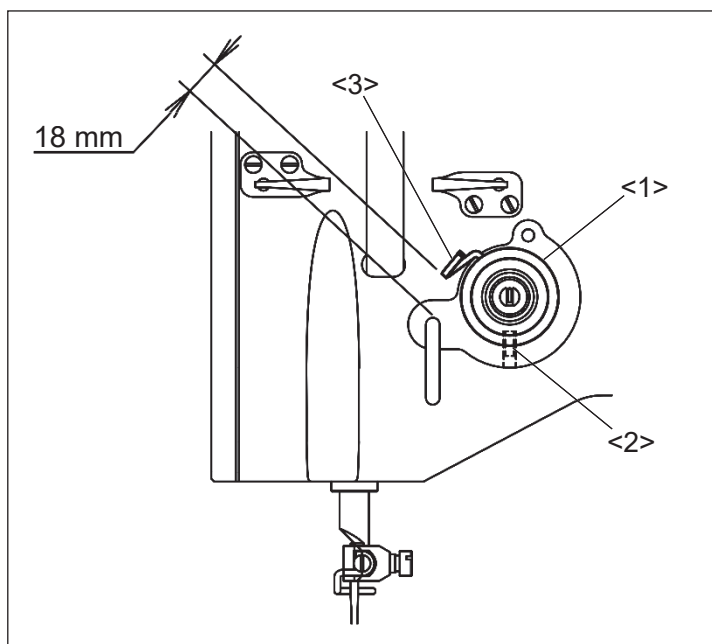

<1>: Thread take up spring unit
<2>: Set screw
<3>: Thread take up spring

6-6-2. Adjusting intensity of the thread take up spring

(1) Insert the screw driver into the slit of the adjusting shaft (No.1) and turn it to the counterclockwise. The adjusting bushing (No.2) come to loose.

NOTE To prevent the deforming or breaking of the adjusting shaft (No.1), loosen the adjusting nut until the adjusting shaft end before operating above.

(2) Turn the adjusting busing (No.2) to adjust the thread take up spring intensity. When turn it to clockwise, the thread take up spring tension becomes tight, and when turn it to counterclockwise, the thread take up spring tension becomes loose.

(3) The standard tension is approximately 2.5 N. To obtain the standard tension, loosen the adjust bushing (No.2) and reduce the tension of take-up spring to 0 then, tighten the adjust bushing (No.2) from that position.

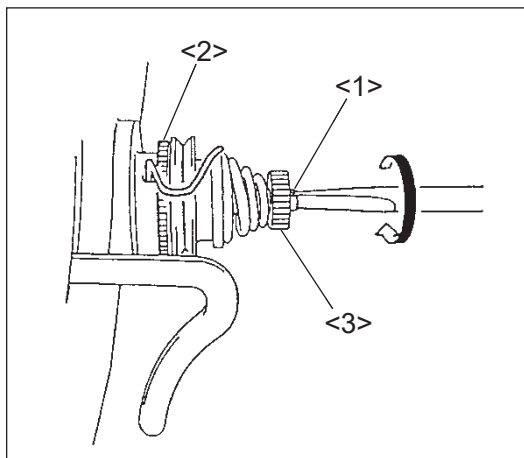

- <1>: Adjusting shaft
- <2>: Adjusting bushing
- <3>: Adjusting nut

6-7. Adjustment of the air pressure



★ If the secondary side air pressure is set too high, trouble such as operation faults may occur. Always set the pressure to within 0.4MPa.

(1) Air pressure is provided from an air source. Lift and turn the air regulator's adjustment knob (No.1) located under the table to adjust the air pressure.

(2) If turn the adjusting knob (No.1) to the clockwise, the air pressure is increased.

(3) If turn the adjusting knob (No.1) to counter clockwise, the air pressure is decreased.

(4) 0.4MPa (4kgf/cm²) is the standard air pressure as a normal sewing operation.

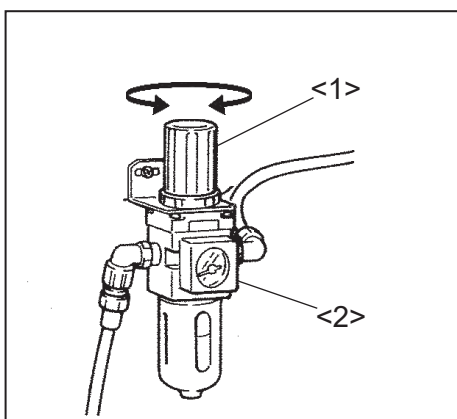

- <1>: Adjusting knob
- <2>: Air regulator

7. VARIOS ADJUSTMENT



CAUTION

- (1) Please make sure to turn the power switch off before adjusting the sewing machine.
- (2) When adjusting the sewing machine with the power switch on, please be careful not to step on the foot switch by mistake.
- (3) Please be careful not to be injured by a sharp part such as the needle and the hook point.
- (4) Please make sure to put the safety guards (eye guards, link covers, and finger guards or the others) back on the initial position after the sewing machine adjustment.

7-1. How to exchanging the tension spring of the needle thread tensioner unit

According to following procedures, exchange the tension spring (No.1).

NOTICE It is required to use the factory original tension spring.

- (1) Turn the thumb screw (No.2) and decrease the tension spring pressure.
- (2) Loosen the set screw (No.4) and then remove the set screw (No.3) and remove the thumb screw (No.2).

The set screw (No.3) and (No.4) are same parts.

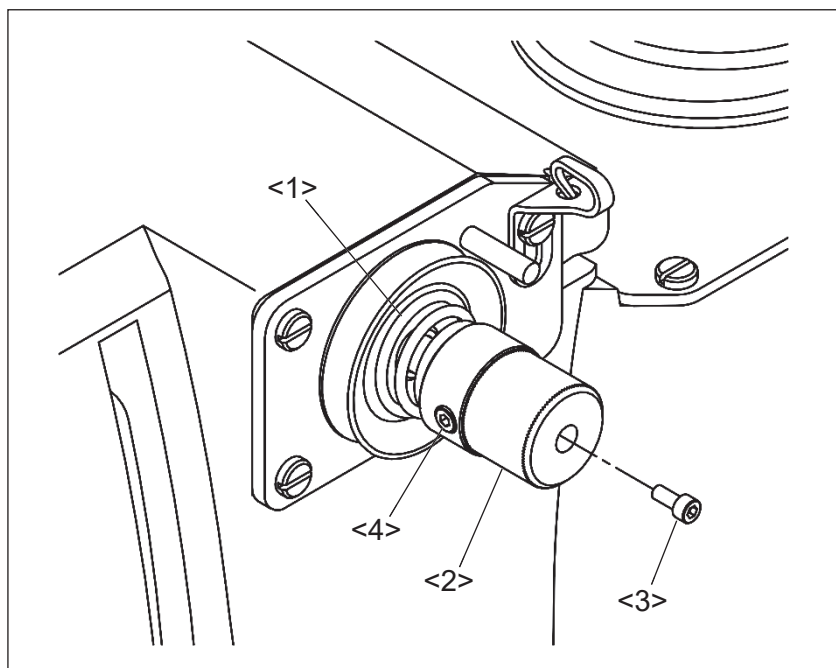

<1>: Tension spring <2>: Thumb screw <3>: Set screw <4>: Set screw

(3) Pull out the thumb screw (No.2) from tensioner shaft (No.5). In this time the bearing (No.6) is removed too.

(4) Remove the tension spring (No.1).

(5) After exchanging the tension spring (No.1) back the bearing (No.6) and thumb screw (No.2) in order.

Then tighten the set screw (No.4) and screw (No.3) in order.

NOTE 1 Bearing (No.6) is consist of three parts. Please taking care not to make misassembling by referring following figure.

NOTE 2 Locate the groove of the tension disc (No.9) to the thread release pin (No.11) when removed tension disc (No.9), (No.10).

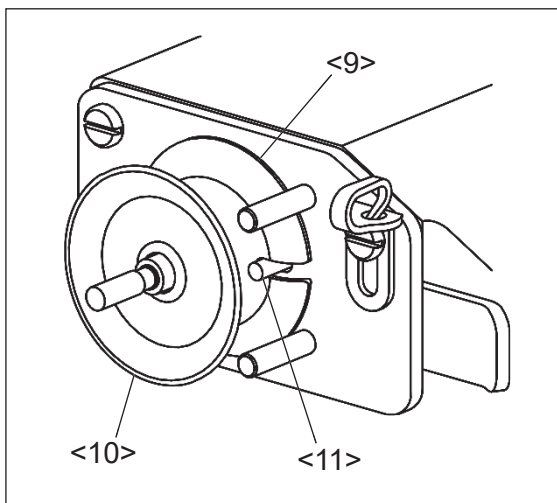
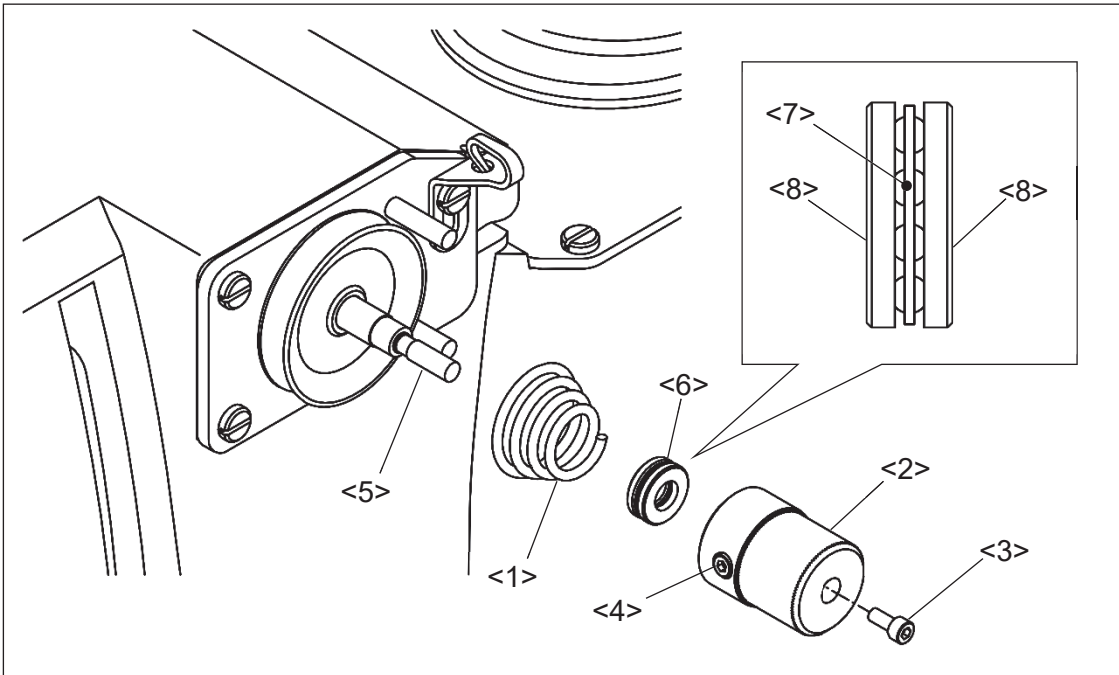

- <1>: Tension spring <2>: Thumb screw <3>: Set screw <4>: Set screw
<5>: Tensioner shaft <6>: Bearing <7>: Bearing holder <8>: Washer
<9>: Tension disc <10>: Tension disc <11>: Thread release pin

7-2. Adjustment of the detector position of the presser foot unit

According to following procedures, adjust the detector position in case of parts replacement etc.

NOTE The presser foot lifting position is setting by 15 mm from top of the sliding plate.

NOTICE The presser foot movement is based on the origin detection position. To prevent the sewing trouble and parts breaking, adjust the detector position exactly.

(1) Remove the eye guard (No.1) by referencing the previous paragraph [3-4. Installation of the eye guard]

(2) Remove the three of fixing screws (No.2) and remove the face cover (No.3).

(3) Remove the needle (No.4).

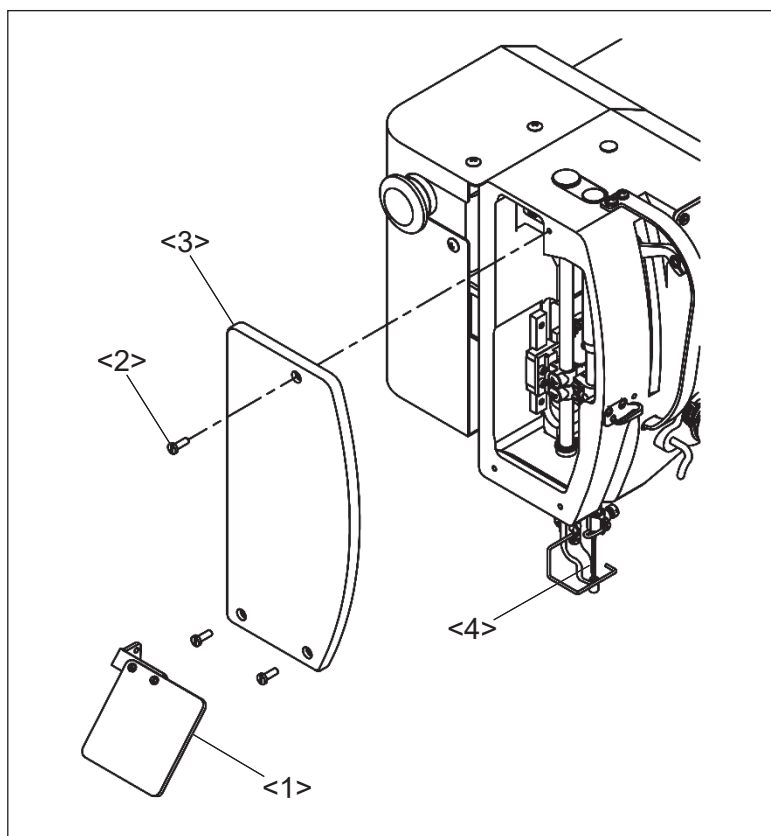

<1>: Eye guard <2>: Fixing screw <3>: Face cover <4>: Needle



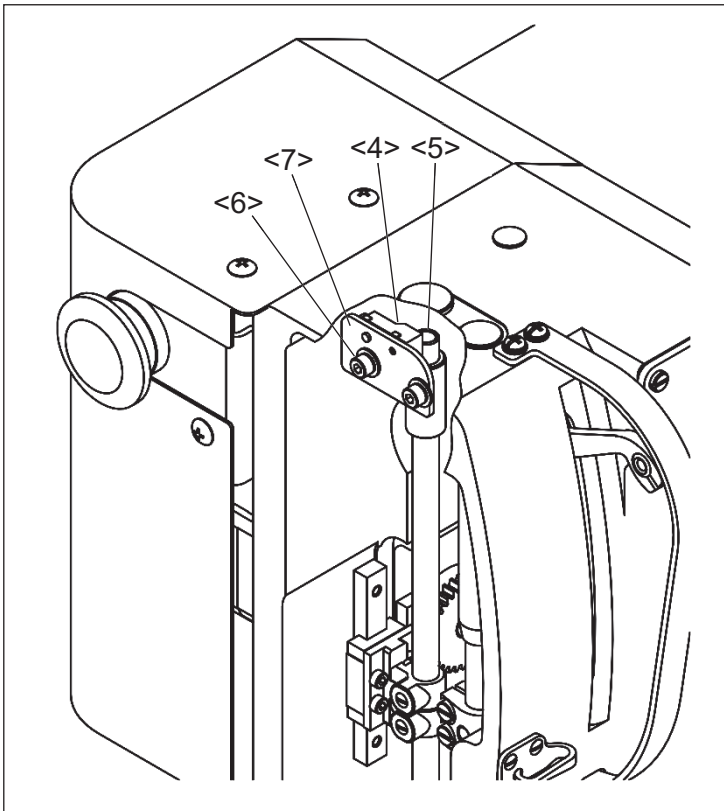

(4) Detector (No.4) is installed in machine head. Detector (No.4) detects end of the presser bar (No.5).



Before adjustment, it is necessary to make sure following items.



- <4>: Detector
- <5>: End of presser bar
- <6>: Fixing screw
- <7>: Detector bracket

(a) Press the  from standard screen and check if the presser foot height value (ZTHK) is [***].
(No setting) If different, please change to the initial set value.

(b) Press the  >  >  >  from standard screen and check if the presser foot lifting value is [15.0 mm]. If different, please change to the initial set value [15.0 mm].

(c) Press the  >  >  > ZNPP [Distance from PF sensor edge to the top surface of slide plate]. Check if the value is [300] (30.0 mm). If different, please change to the initial set value [300].

(d) For prevent the detection error, please use the factory default presser foot.

- (5) Loosen the fixing screw (No.6) and move the detector bracket (No.7) upward in advance then tighten the fixing screw (No.6) temporarily.
- (6) Remove the sewing material and work holder and any parts. After make sure the work environment safety, Turn the power switch on.
- (7) After finish the origin movement, make sure the clearance between the bottom of presser foot and top of the sliding plate is 15 mm. If this clearance is more, loosen the fixing screw (No.6) and move downward the detector bracket (No.7) and tighten the screw again and press the origin return icon.

NOTICE Please be careful not to step on the foot switch by mistake.

- (8) Continue the above adjustment up to be a correct distance 15 mm.

NOTICE From the second home position returning, it does not use the home position return sensor. Make sure to turn the power switch off to change the mechanical home position.

To use the sensor from the second returning, press **Program** > **home position** > **SHP**

[Home returning method since the second time returning] on the standard screen and set it ON.

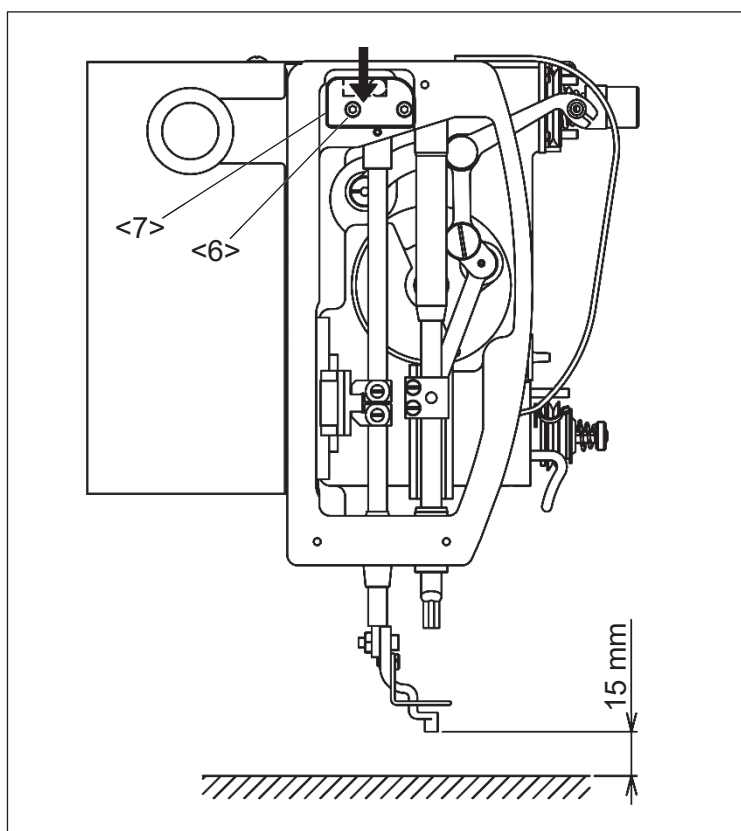

<6>: Fixing screw

<7>: Detector bracket

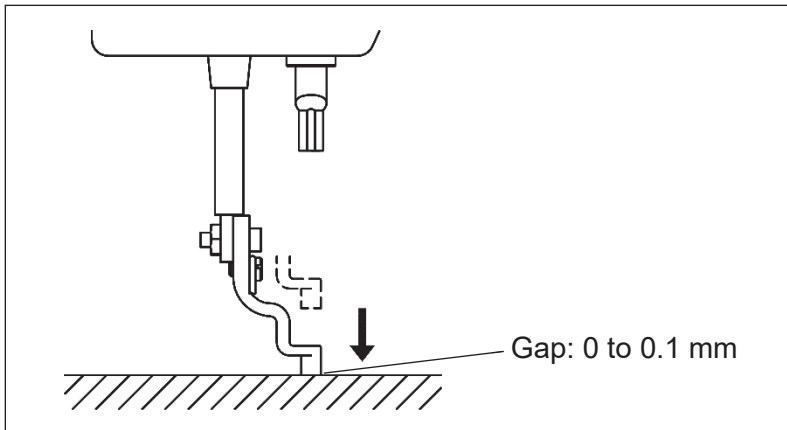

(9) Press the presser foot down icon and check the gap between bottom of presser foot and top of sliding plate is 0 to 0.1 mm. If there is any collision sounds when down the presser foot, please readjust above. If the gap more than 0.1 mm, please readjust too.

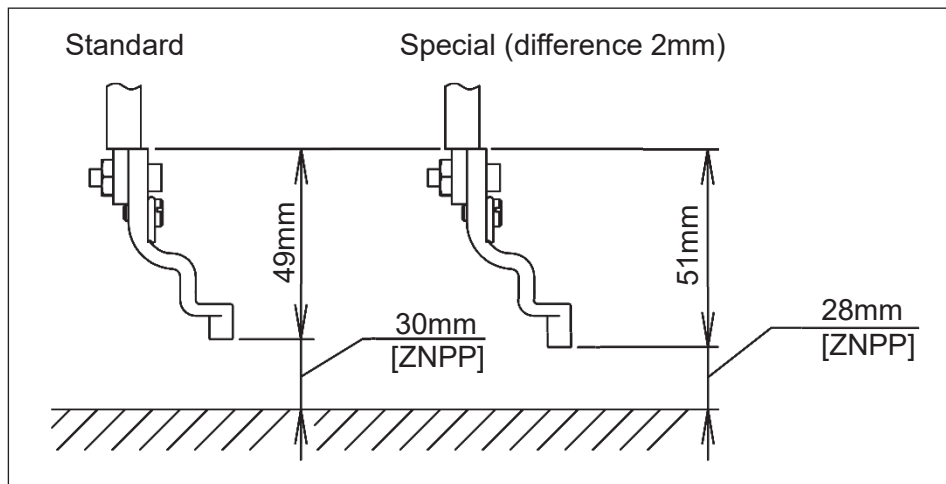

7-3. How to replace with a special presser foot

When replace the standard presser foot only at needed, it is necessary to change the ZNPP [Distance from PF sensor edge to the top surface of needle plate] from default value. For example, to using a special presser foot which length is 2 mm longer, change the value to [280] (28.0 mm) from default value [300] (30.0 mm) as showing in the following figure. According to the following procedures change the ZNPP value.



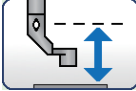

(1) Press the  >  >  >  [PF position adjustment] from standard screen.

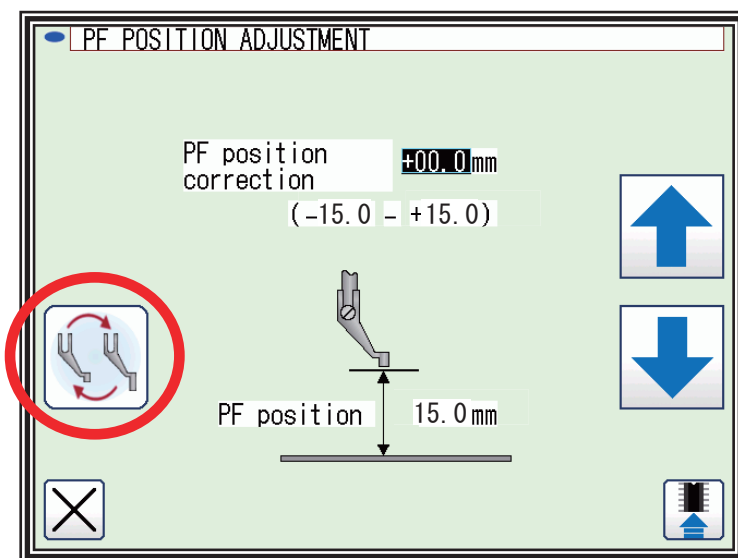
(2) Press the  icon from the [PF position adjustment] screen.





(3) Replace the presser foot with standard one.

(4) Press the   icon and down the presser foot to the top of the needle plate. In this time, set the gap between bottom of presser foot and top of needle plate to be 0 to 0.1 mm. The screen indicates ZNPP default value (Upper) and current value (Lower).

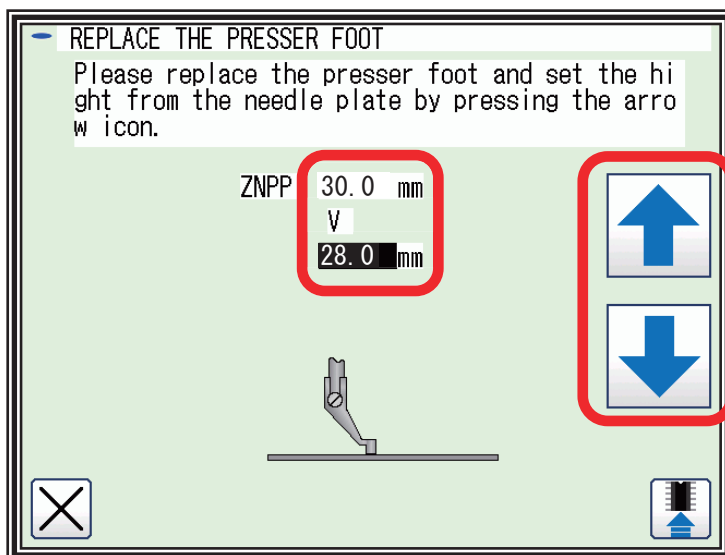
NOTE The ZNPP value can be set every 0.1 mm.



(5) After the completion of setting, press the memory icon  and then press the  icon.

NOTE The ZNPP value is flickering until press the  icon.

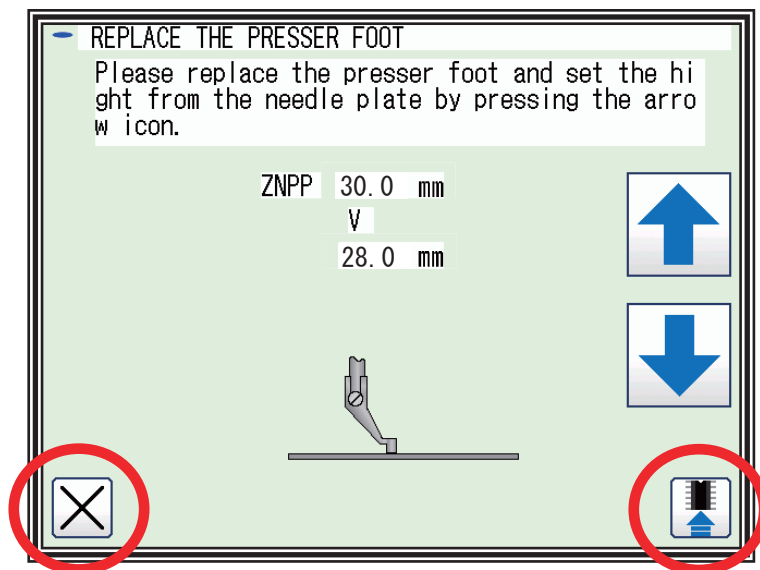

(6) Following the screen indication, put the power switch off.

7-4. Adjustment of the presser foot holder position

- (1) Turn off the machine power and down the presser foot (No.7) by hand to the top of the sliding plate.
- (2) Loosen the each of set screws (No.5) which has presser foot holder (upper) (No.3) and presser foot holder (lower) (No.4).
- (3) Align the bottom of the rack gear (No.1) with bottom of the guide rail (No.2) by moving the presser foot holder (upper) (No.3) and presser foot holder (lower) (No.4) position.
- (4) After adjustment make sure if the presser foot (No.7) is remaining on the sliding plate. On the other hand, adjust the presser foot hole position to the needle (No.8) with turning the presser bar.
- (5) Then tighten the each of set screws (No.5) securely while holding the block (No.9) by both presser foot holders (No.3), (No.4) and make sure if there are no gap between both presser foot holders (No.3), (No.4) and block (No.9).

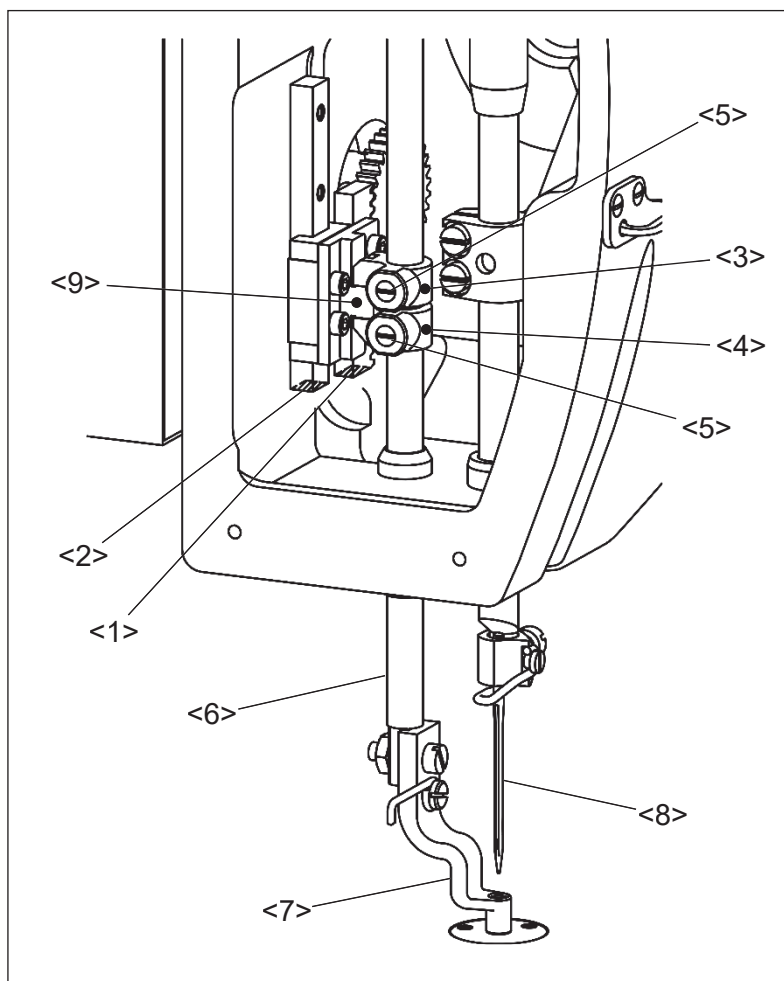

- <1>: Bottom of the rack gear
- <2>: Bottom of the guide rail
- <3>: Presser foot holder (upper)
- <4>: Presser foot holder (lower)
- <5>: Set screw
- <6>: Presser bar
- <7>: Presser foot
- <8>: Needle
- <9>: Block

7-5. Adjustment of the thread trimmer

When remove the component of the thread trimmer mechanism for maintenance, please refer to following adjustment procedures.

7-5-1. Adjustment of the movable knife

(1) Remove the sliding plate (No.1) by referring to the paragraph <6-2-1>.

(2) Aligning the center of the trimmer link hole (No.2) with the reference hole (No.3) as below figure.

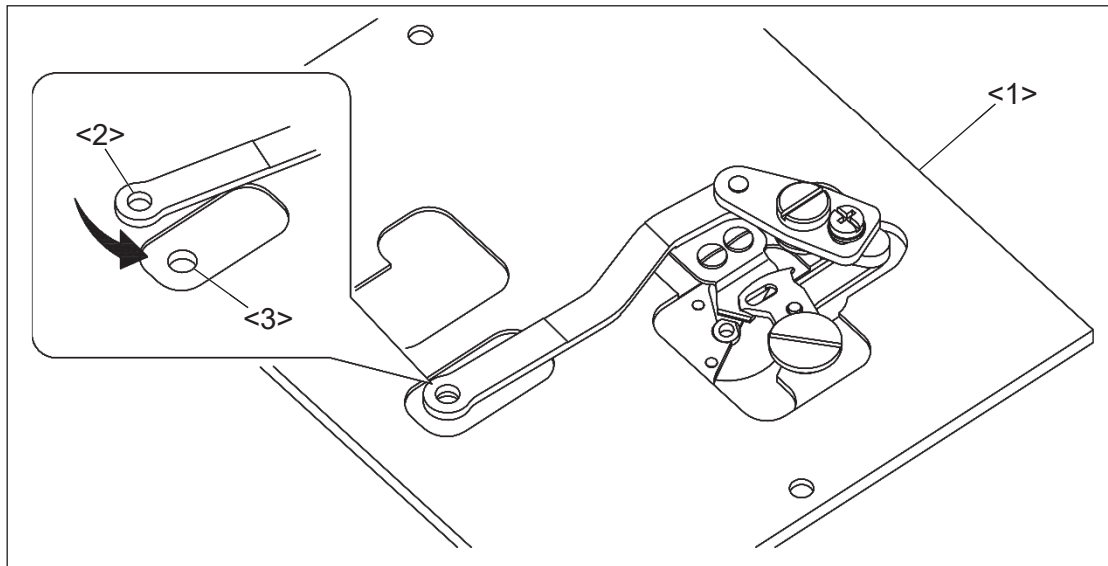

<1>: Sliding plate <2>: Trimmer link hole <3>: Reference hole

(3) Please confirm if the tip of movable knife (No.5) is on a virtual plane of the machining surface of sliding plate (No.4) as below figure. In this time, keep aligning the center of the trimmer link hole (No.2) and the reference hole (No.3).

(4) If different, loosen the screw (No.6) and adjust the tip of movable knife (No.5) position by moving in the arrow direction. In this time, keep aligning the center of the trimmer link hole (No.2) and the reference hole (No.3) too.

(5) After adjustment, tighten the screw (No.6) and reconfirm the tip of movable knife (No.5) position.

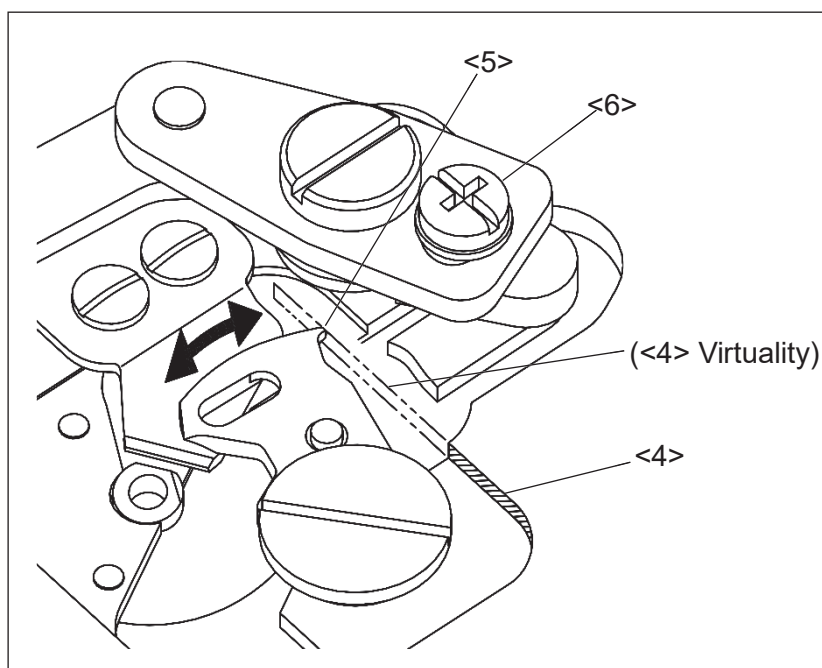

<4>: Machining surface
<5>: Tip of movable knife
<6>: Screw

7-5-2. Adjustment of the fixed knife

(1) Confirm the clearance between blade edge of fixed knife (No.1) and edge of the needle plate (No.2) is 1.5 mm.

(2) If different, loosen the screw (No.3) and adjust the clearance.

NOTE If the clearance is smaller than 1.5 mm, it may cause any trimming failure or unstable trimming length.

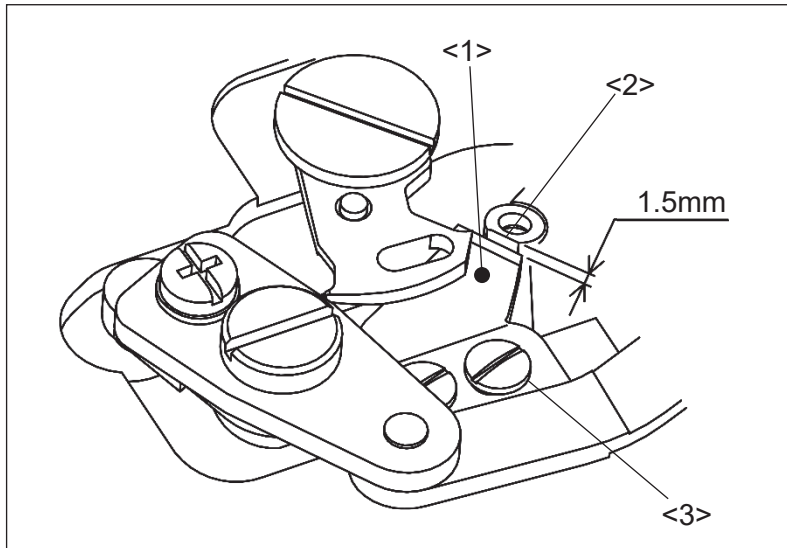

<1>: Fixed knife

<2>: Edge of the needle plate

<3>: Screw

7-5-3. Adjustment of the trimmer cam detector position

The trimmer system has origin detector (No.2) which detects outer periphery of the cam roller (No.5). The trimmer system's home position is the movable knife standby position which described previous paragraph <7-5-1. Adjustment of the movable knife >. According to following procedures, adjust the detector (No.2) position.

- (1) Turn the power switch off.
- (2) Put the machine power on and press the home position icon from standard screen.
- (3) After finish the origin movement, please check the clearance from "A" direction between trimmer cam (No.1) and cam roller (No.5) is 0.5 mm or less.

NOTE It is necessary readjust the detector position when the trimmer cam (No.1) contact with cam roller (No.5). In this case, movable knife position may different.

- (4) Turn the machine power off and loosen the two of the screws (No.3) and change the detector bracket (No.4) position by moving in the either of arrow direction and confirm above condition.

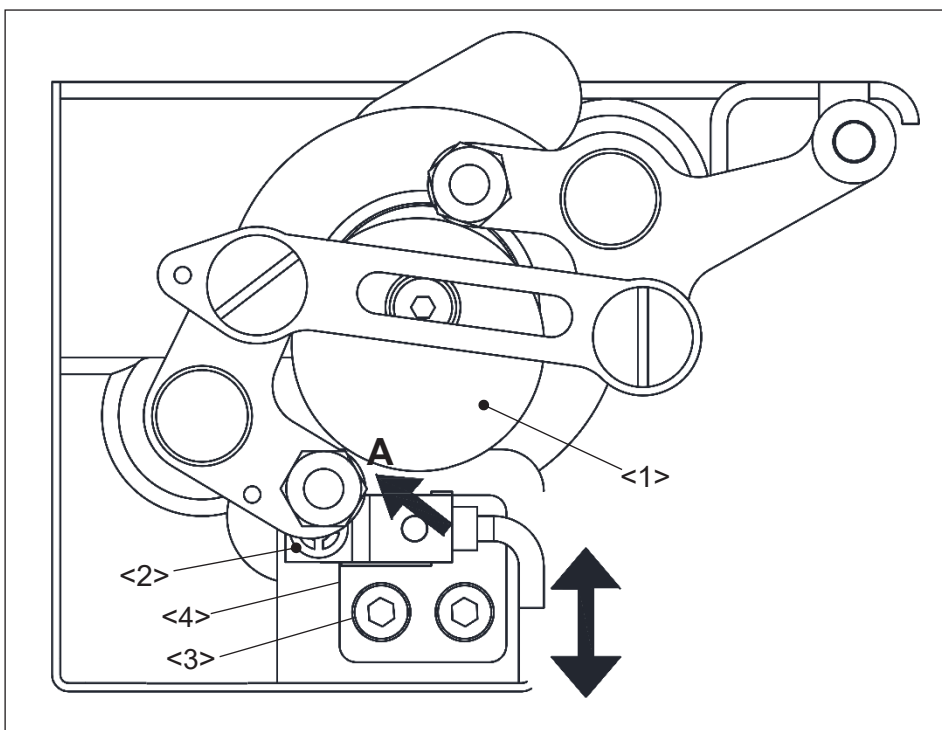

- <1>: Trimmer cam
- <2>: Detector
- <3>: Screw
- <4>: Detector bracket
- <5>: Cam roller

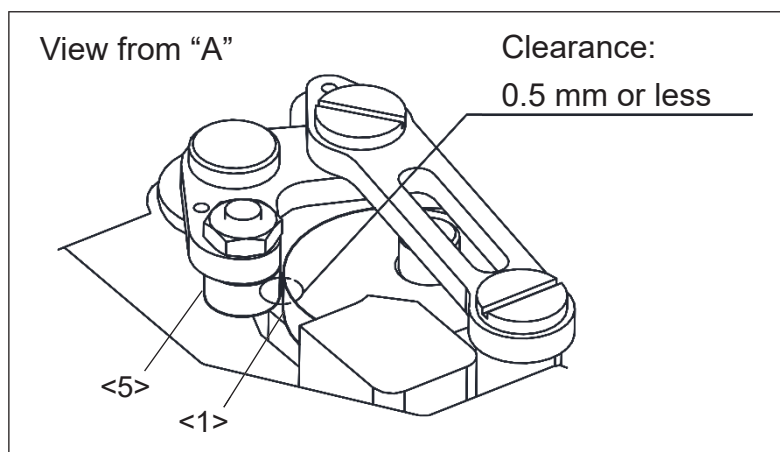

7-6. How to remove the XY cover

When remove the XY cover (No.1) by maintenance, please refer to the following procedures.

NOTICE For the safety, please operate more than one person.

(1) Remove the each one of the screw (No.2) and (No.3) from machine right side.

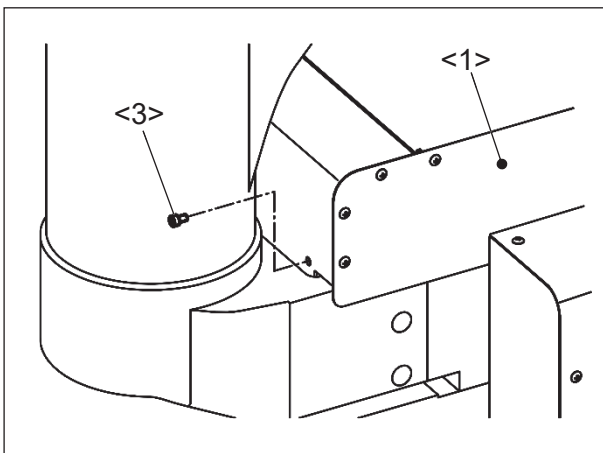
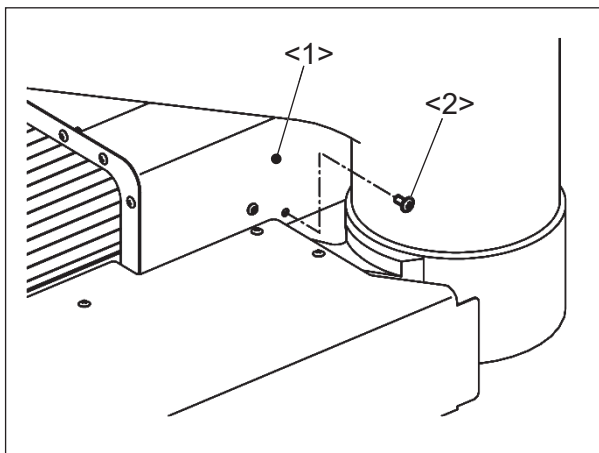

(2) Remove the two of the screws (No.2) from machine left side.

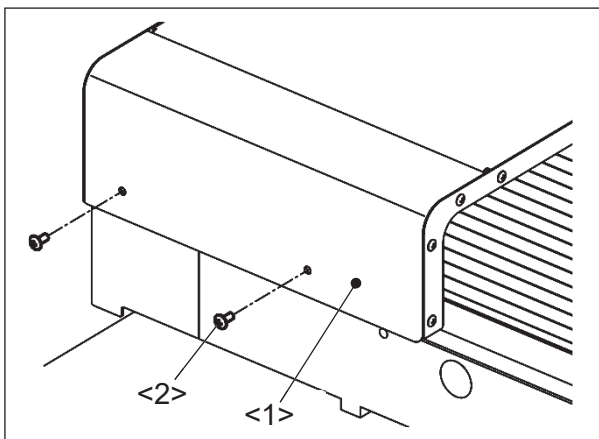

(3) Lift up the XY cover (No.1) up to the bottom of machine arm and move in the arrow direction. XY cover (No.1) can be removed. Please operate more than one person and pay attention to XY table and flexible tube.

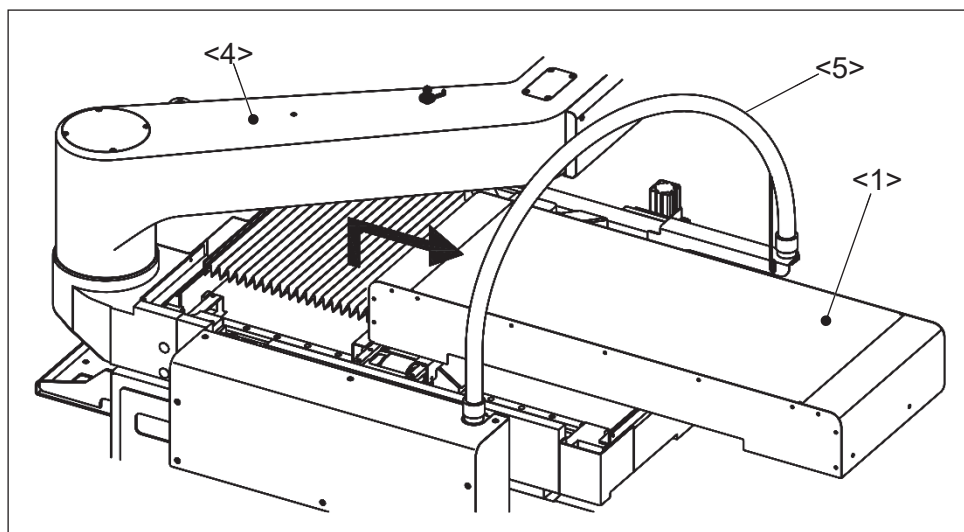

<1>: XY cover <2>: Screw <3>: Screw <4>: Machine arm <5>: Flexible tube

7-7. Adjustment of the XY table detector

XY table detecting position is front left corner of sawing area to the needle center. At the first origin movement when turn the machine power on, XY table moves toward above position. After detection, XY table is back to the center of the sawing area. Before adjusting, it is necessary to remove the XY cover. Please refer to the previous paragraph [7-6.].

[NOTE] When modify the home position somewhere other than the center of sewing area, please refer to the instructions **OPERATION PANEL** technical manual [18] [Easy setting 3-(5)].

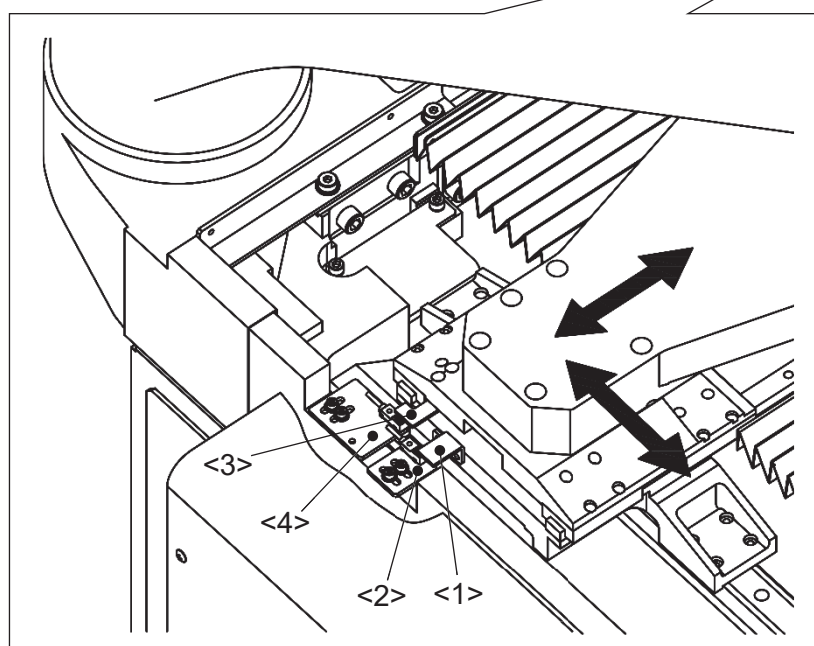
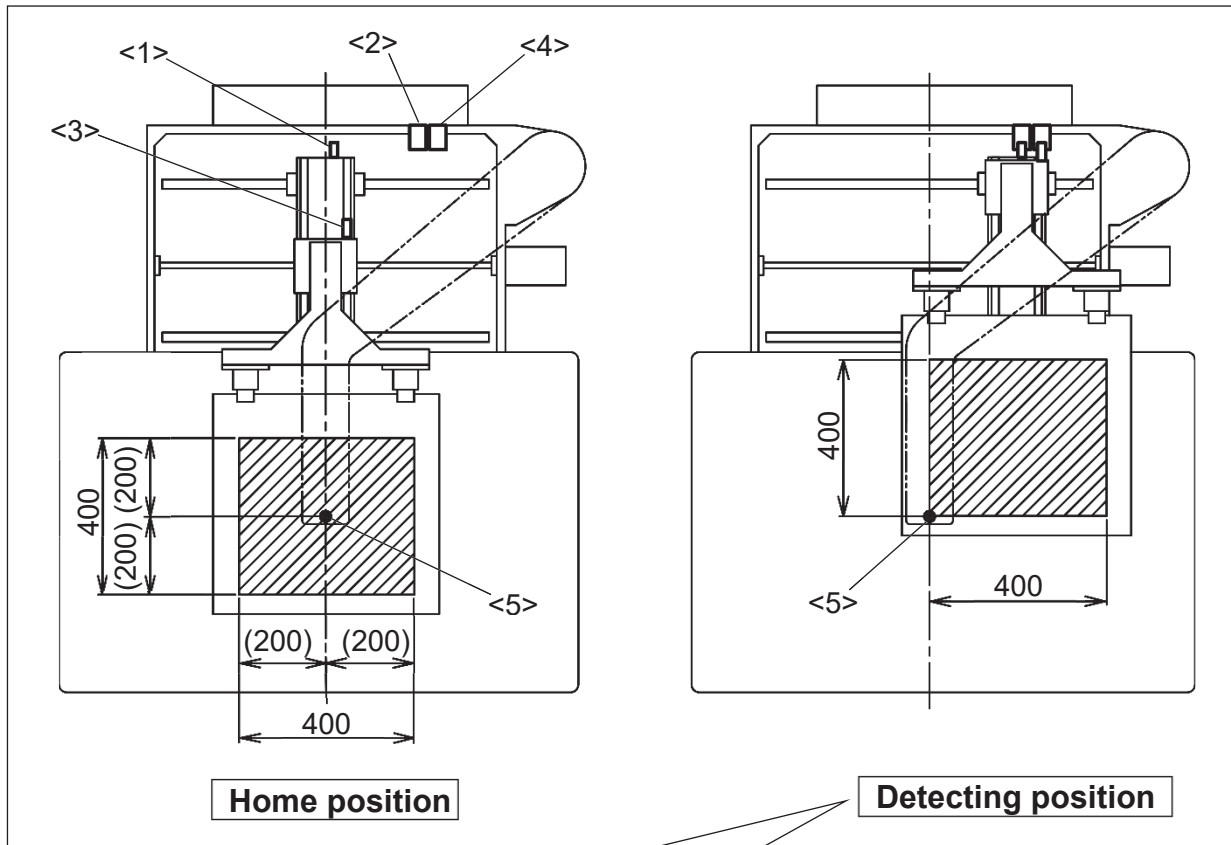

- <1>: X detect plate
- <2>: X detector
- <3>: Y detect plate
- <4>: Y detector
- <5>: Needle

NOTICE The machine has a function that the motor memorizes the home position at the first home position returning operation after the switch is turned on. Therefore, from the second home position returning, it does not use the home position return sensor. Make sure to turn the power switch off to change the mechanical home position.

To use the sensor from the second returning, press **Program** > **home position** > **SHP** [Home returning method since the second time returning] on the standard screen and set it ON.

7-7-1. Adjustment of X direction

- (1) Turn the power switch on and press the home position return icon .
- (2) Turn the power switch off when finish the origin return movement.
- (3) Confirm the distance between X stopper (No.6) and Movable frame (No.7) which showing in hatched area is 210 mm. If different, loosen the two screws (No.8) of the X detector (No.2) and adjust the detectors position. When above distance is more than 210 mm, move the X detector (No.2) in arrow “b” direction. When less than 210 mm, move the X detector (No.2) in arrow “a” direction.
- (4) After adjustment, tighten the screw (No.8) and check again above (1) to (3) procedures.
- (5) Confirm the clearance between detector and detect plate is in the range of 1 to 1.5 mm. If it has any damage with detector or the detect plate, this clearance may different.

NOTICE For the safety, turn the power switch off every time.

NOTE XY table mechanical home position is the center of the sawing area to the needle center. If modified the home position by control panel, please return the setting to default value in advance.

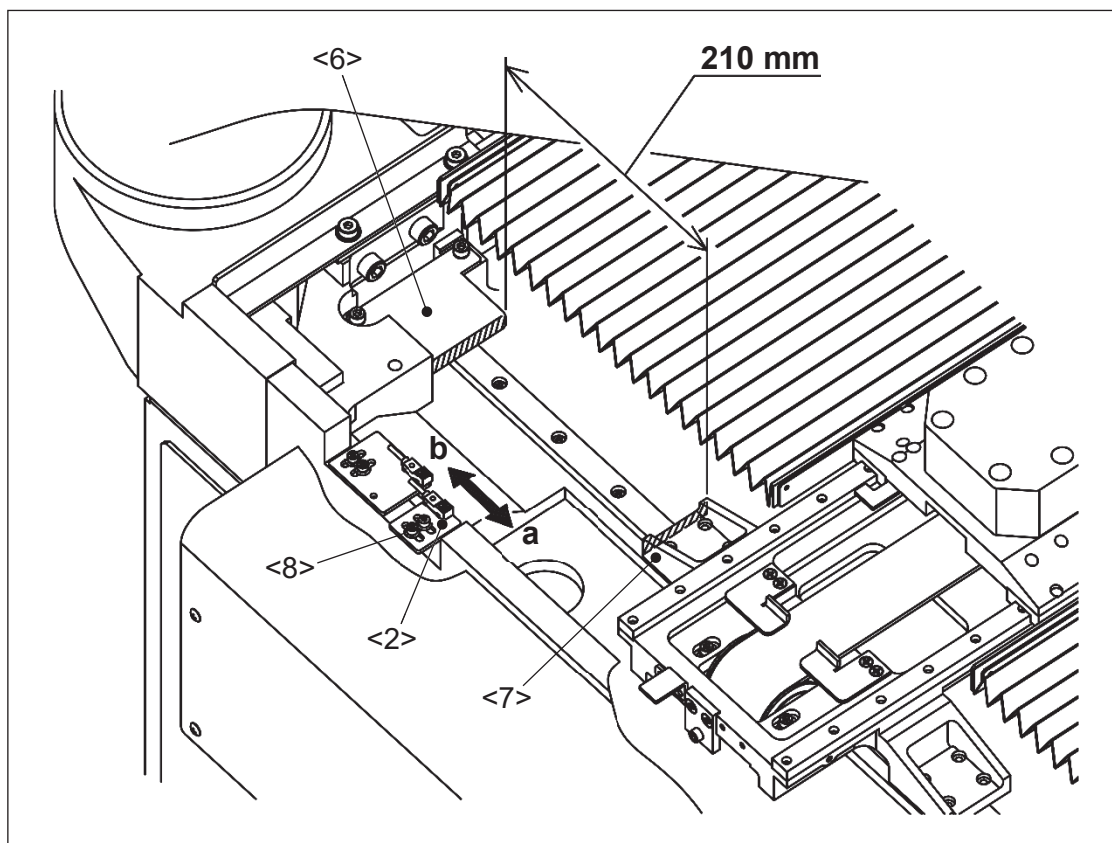

<2>: X detector <6>: X stopper <7>: Movable frame <8>: Screw

7-7-2. Adjustment of Y direction

(1) Turn the power switch on and press the home position return icon .

(2) Turn the power switch off when finish the origin return movement.

(3) Confirm the distance between Y stopper (No.10) and Y Movable race (No.9) which showing in hatched area is 120 mm. If different, loosen the two screws (No.8) of the Y detector (No.4) and adjust the detectors position. When above distance is more than 120 mm, move the Y detector (No.4) in arrow “b” direction. When less than 120 mm, move the Y detector (No.4) in arrow “a” direction.

(4) After adjustment, tighten the screw (No.8) and check again above (1) to (3) procedures.

(5) Confirm the clearance between detector and detect plate is in the range of 1 to 1.5 mm. If it has any damage with detector or the detect plate, this clearance may different.

NOTICE For the safety, turn the power switch off every time.

NOTE XY table mechanical home position is the center of the sawing area to the needle center. If modified the home position by control panel, please return the setting to default value in advance.

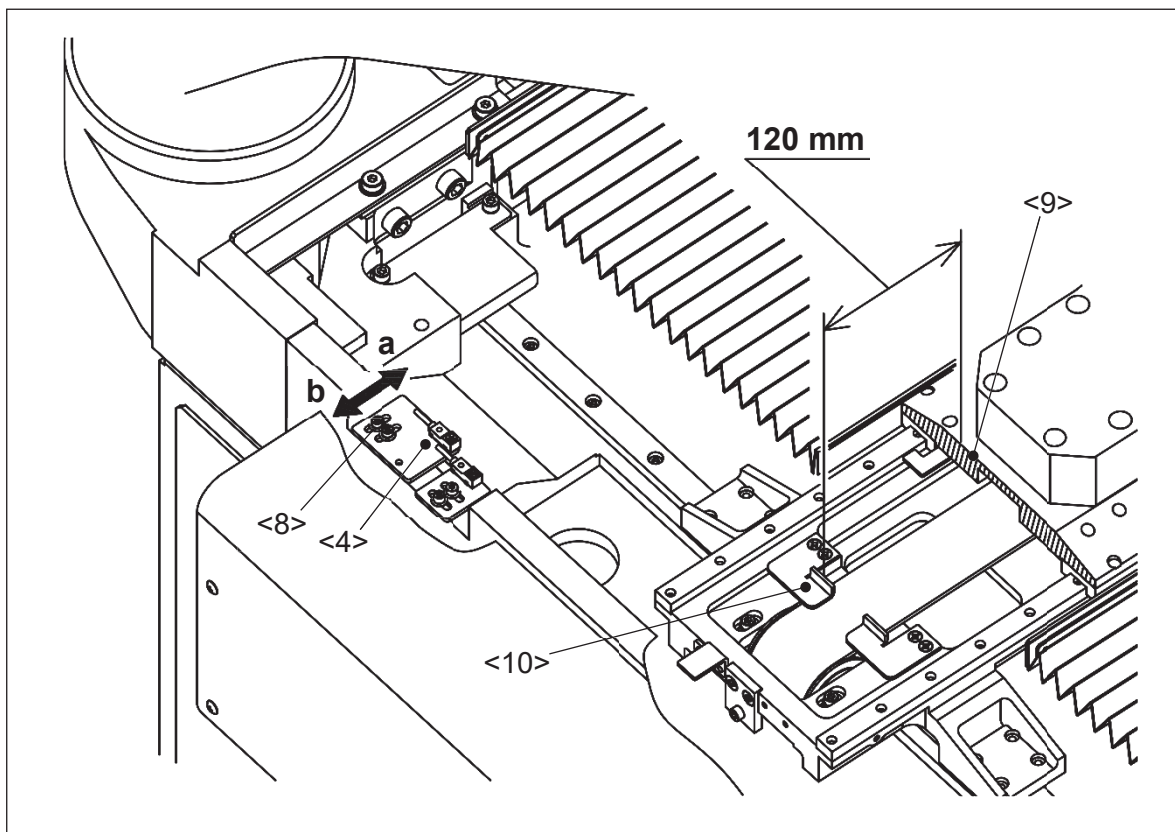

<4>: Y detector <8>: Screw <9>: Y movable race <10>: Y stopper

7-8. Adjustment of the Y timing belt tension

- (1) Remove the XY cover.
- (2) Loosen the two screws (No.1) of the pulley bracket.
- (3) Tighten the adjust screw (No.2), the timing belt (No.3) tension will be increased.
- (4) After the adjustment, tighten the screws (No.1).

Reference Y timing belt tension has been adjusted by 440 (N).

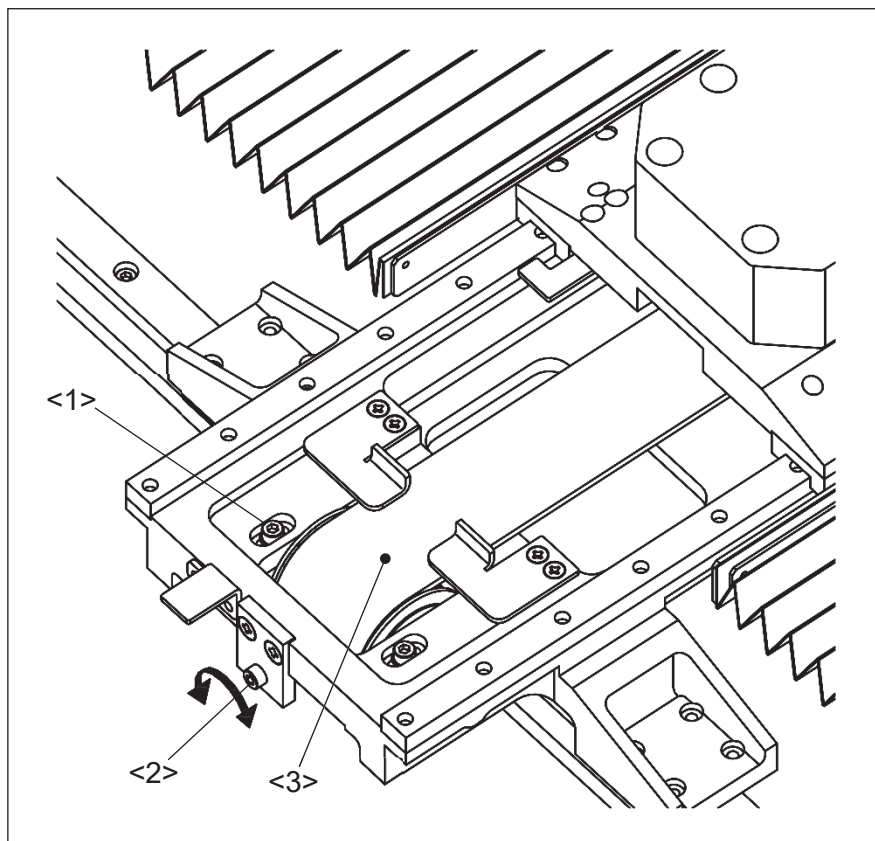

- <1>: Screw
- <2>: Adjust screw
- <3>: Timing belt

8. MAINTENANCE



- (1) Please make sure to turn the power switch off before cleaning the sewing machine.
- (2) Please pay attention to that staining your skin or eyes with oil may cause an inflammation.

8-1. Cleaning

- (1) Remove the dust and the thread waste sticking regularly.

8-2. Greasing

- (1) The dust or the like sticking absorbs lubrication oil on the rails and significantly lowers the slide guide running life. Remove the dust and the thread waste sticking regularly and greasing every six months.
- (2) For the guide rail, grease to the both side of guide groove. For the spline shaft and ball screw shaft, grease to the surface of shaft. After greased, apply the grease uniformly by moving the XY table by hand.

NOTE This operation required to removing the XY cover and shutter.

- <1>: X guide rail
- <2>: Y guide rail
- <3>: Spline shaft
- <4>: Ball screw shaft

Recommended grease: Lithium grease 2

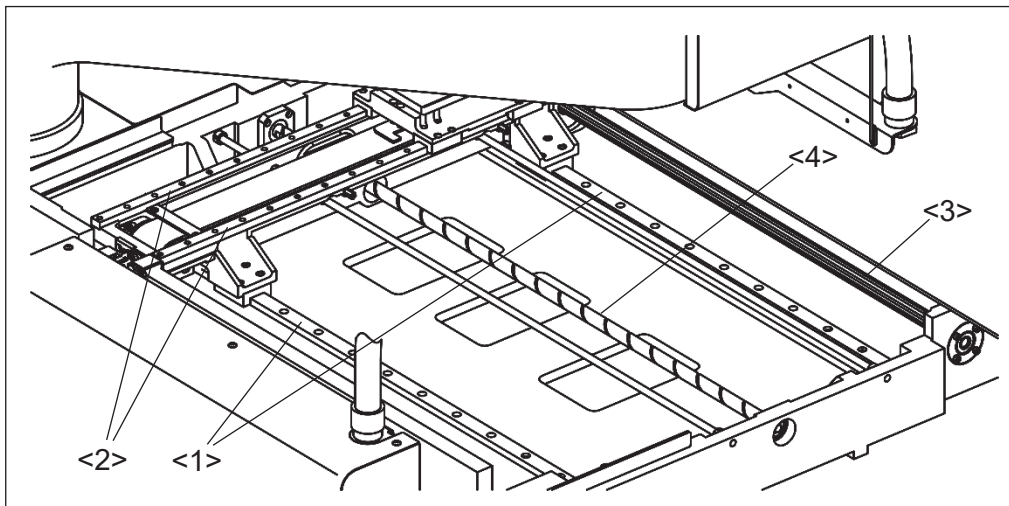

(3) Grease every six months to the following units which consisted by gear mechanism.

NOTE Remove the face cover and motor cover in advance.

<5>: Rack gear which has presser foot unit.

<6>: Gear of the needle thread tensioner drive unit.

Recommended grease: Molybdenum disulfide grease

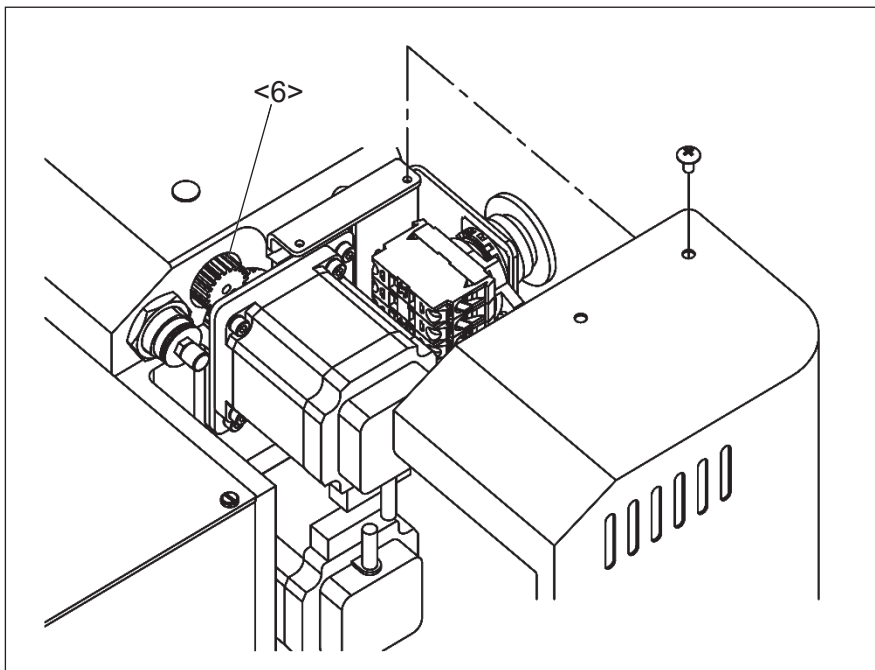
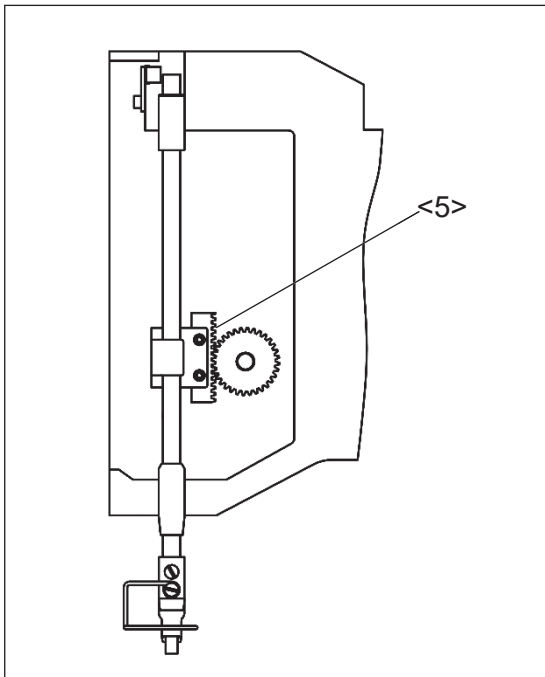

8-3. Disposing of oil waste

If the waste oil pan is full filled in the oil bottle (No.1), remove the oil bottle then dispose of the waste oil.

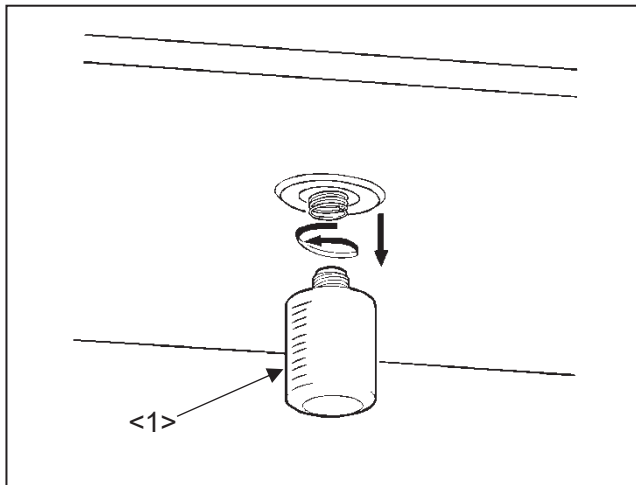

<1>: Oil bottle

9. TROUBLESHOOTING



CAUTION

(1) Please make sure to turn the power switch off before adjusting the sewing machine.

(2) If the adjustment is required while the power switch on, do not step on the foot switch by mistake.

| Condition | Cause | Corrective action | Reference |
|---|--|--|-------------------------|
| Upper thread is broken. | Upper thread tension is too tight. | Adjust thread tension. | 5-10 |
| | Strength of thread take up spring is inappropriate. | Adjust thread take up spring. | 6-6-2 |
| | Parts on needle plate, hook, and presser foot touching thread are damaged. | Grind parts or change parts. | - |
| | The needle size is bigger than the thread size. | Change the needle size to suitable size. | 5-1 |
| | Thread melts with heat. | Slow down the sewing speed | Operation panel section |
| Use needle cooler. | | - | |
| Bobbin thread is broken. | Bobbin thread tension is too tight. | Adjust thread tension. | 5-9 |
| | Parts on needle plate and presser foot touching thread are damaged. | Buff parts or change parts. | - |
| Upper thread is pulled from needle hole when starting sewing. | Thread take up spring tension is too much. | Adjust thread take up spring tension. | 6-6-2 |
| | Sewing speed is inappropriate when starting sewing | Use [e-stitch] function. (Program mode > Sewing speed group > OPLC is ON) | Operation panel section |

| | | | |
|----------------------------------|--|--|-------------------------|
| Frequent skip stitching happens. | Clearance between needle and hook is too big. | Adjust clearance between needle and hook properly. | 6-2-1 |
| | Timing of needle and hook is not proper. | Adjust position of needle and hook properly. | 6-2-3 |
| | Needle is bent. | Change needle. | 5-1 |
| | Needle is at wrong position. | Fix position properly. | 5-1 |
| | Presser foot position is not proper. | Adjust presser foot position. | 6-5 |
| | Presser foot up and down timing is not proper. | Adjust presser foot up and down properly. | 6-5 |
| Trimming is not functioned. | Fixed knife is dull. | Sharpen fixed knife or change fixed knife. | - |
| | Movable knife is dull. | Sharpen Movable knife or change fixed knife. | - |
| | Movable knife home position is not proper. | Adjust movable knife home position. | 7-5-1 |
| | Setting of trimming timing is not proper | Adjust the trimming timing. | Operation panel section |
| | Trimming setting is off. | Turn trimming setting on. | Operation panel section |
| Stitch forming is loose. | Upper thread tension is too loose. | Adjust upper thread tension. | 5-10 |
| | Bobbin thread tension is too loose. | Adjust bobbin thread tension. | 5-9 |
| | Strength of thread take up spring is inadequate. | Adjust strength of thread take up spring. | 6-6-2 |
| | Presser foot position is not proper. | Adjust presser foot position properly. | 6-5 |

| | | | |
|------------------------------------|---|---|-------------------------|
| | Presser foot up and down timing is not proper. | Adjust presser foot up and down properly. | 6-5 |
| | Sewing material is not held | Hold the sewing material sufficiently. | - |
| Jig eject system does not work. | Foot switch is broken. | Change foot switch. | - |
| | Air presser is not strong enough | Increase air presser | 6-7 |
| Sewing pattern is changed. | Work holder is not held by jig eject system. | Modify the cassette jig position. | 5-7 |
| | Sewing material in work clamp slips. | Put slip stopper on presser plate. | - |
| | Sewing material is too heavy. | Slow down sewing speed. | Operation panel section |
| | Y timing belt tension is loose. | Adjust timing belt tension properly. | 7-8 |
| Returned home position is changed. | Ambient temperature is out of use range. | Use sewing machine in ambient temperature in 5 degrees to 35 degrees. | - |
| | Clearance between detector and detecting subject is too wide. | Adjust clearance in 1 to 1.5mm. | 7-7 |
| Oil consumption is too much | Oil amount is too much. | Reduce the oil amount | 6-4 |
| Hook noise is loud | Oil amount is less | Increase the oil amount | 6-4 |

10-1. The positional relationship between the sewing area and jig eject system

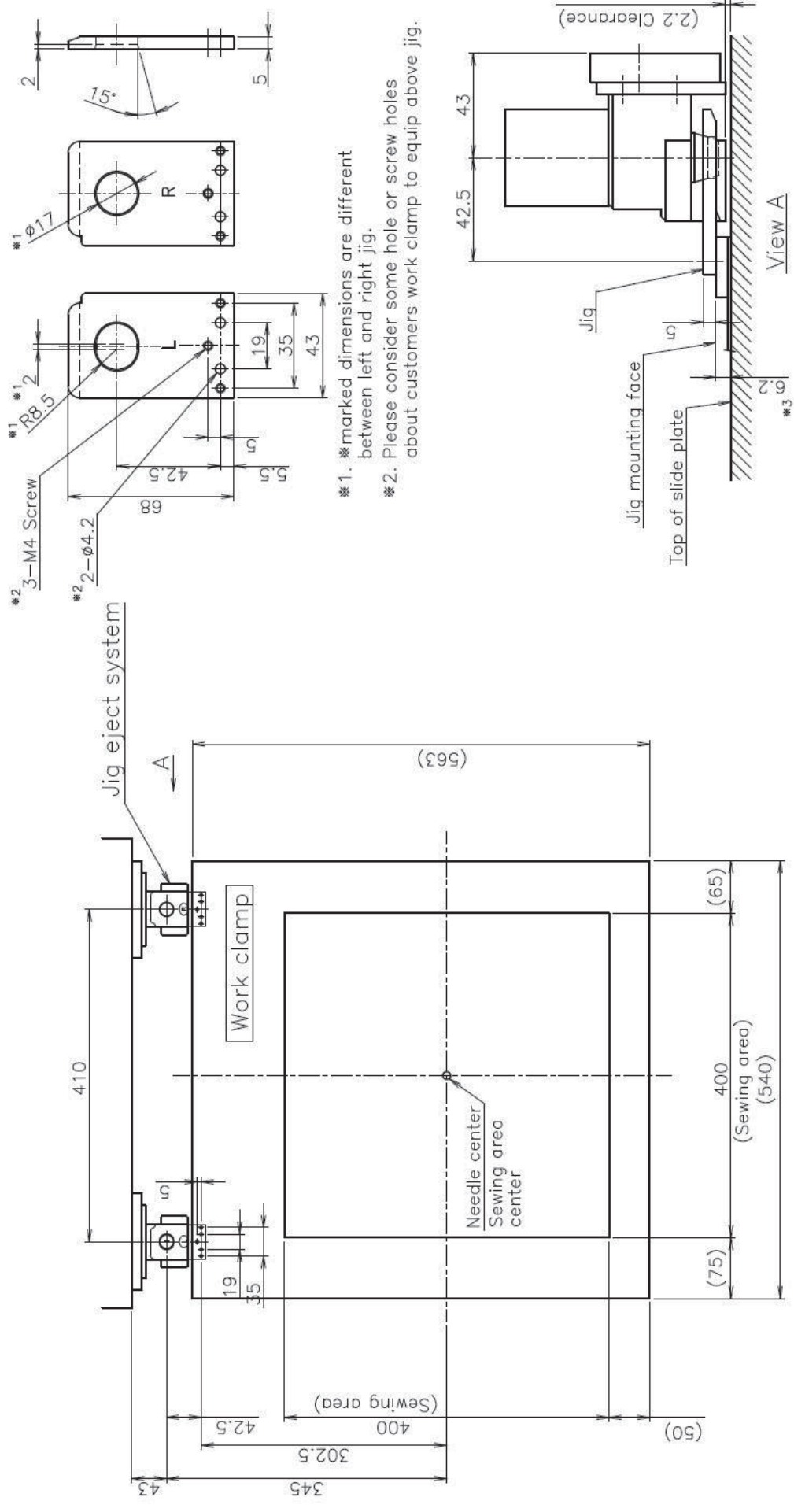

- *1. *marked dimensions are different between left and right jig.
- *2. Please consider some hole or screw holes about customers work clamp to equip above jig.

*3. Reference height of the jig mounting face

10-2. Air piping drawing

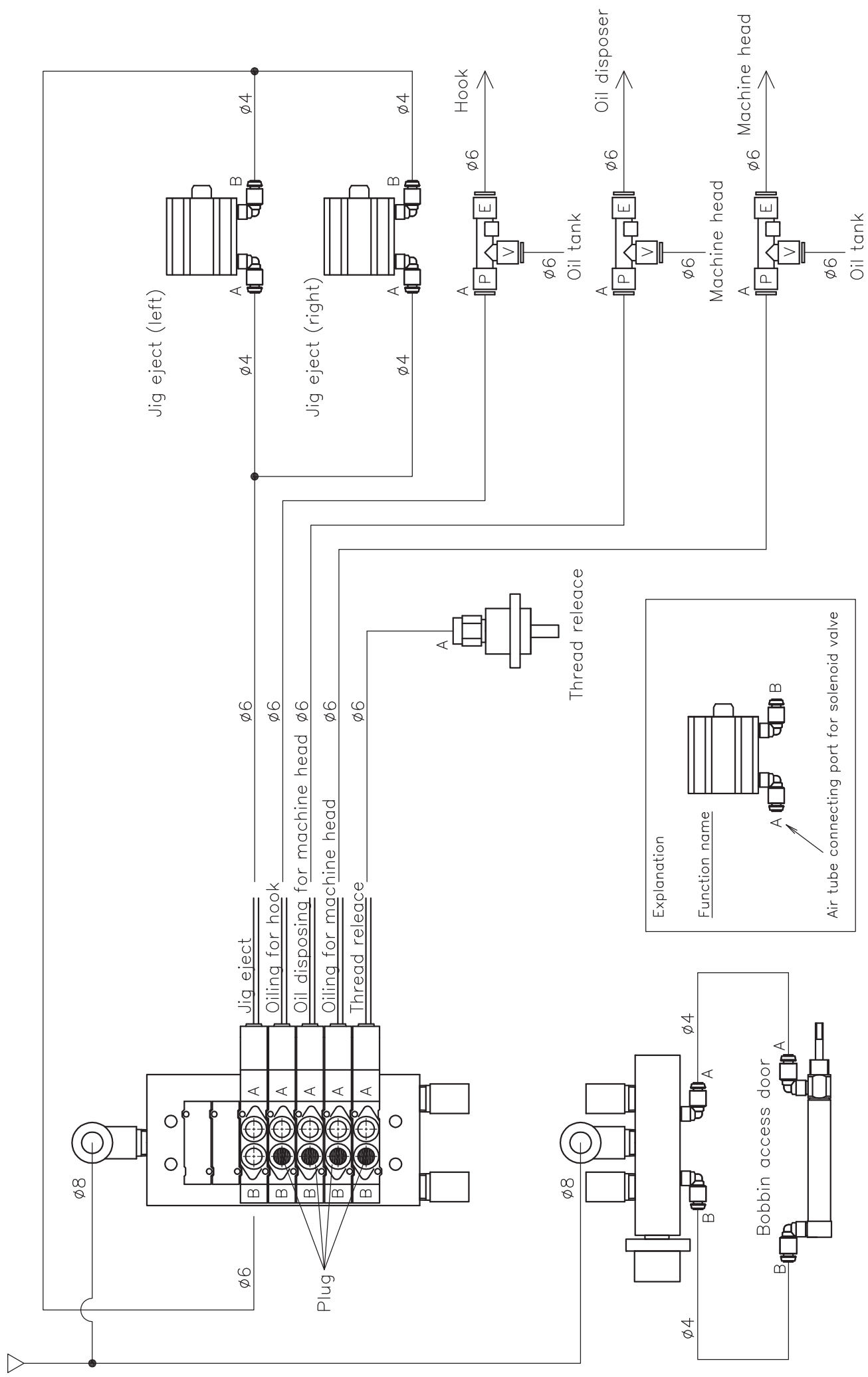

Explanation

| Function name |
|---|
| Air tube connecting port for solenoid valve |

MEMO

A large rectangular area for writing, bounded by a solid line on the top and sides, and a solid line at the bottom. The interior is filled with horizontal dashed lines, providing a guide for writing.

MEMO

A large rectangular area for writing, bounded by a solid line on the top and sides, and a solid line at the bottom. The interior is filled with horizontal dashed lines, providing a guide for writing.

JUKI CORPORATION

Printed in Japan