

JUKI®

INDUSTRIAL SEWING MACHINE

MODEL

PLK-J4040

TECHNICAL MANUAL

SEWING MACHINE HEAD

FOR SAFE USE

Before the installation, operation, and inspection for this product, read the “FOR SAFE USE” and the technical manuals carefully. Also read the other technical manuals, “Control Unit” and “Operation Panel” describing some instructions, which are not in this manual, and use the sewing machine properly.

SAFETY INDICATIONS

	DANGER	Indicates that incorrect handling may cause hazardous conditions, resulting in death or severe injury.
	CAUTION	Indicates that incorrect handling may cause hazardous conditions, resulting in medium or slight personal injury or physical damage. Note that CAUTION level may lead to a serious consequence according to the circumstances. Always follow the instructions of both levels because they are important to personal safety.

CAUTION INDICATIONS

No.	Caution indication	Description
1		<p><u>Precaution for sewing machine operation:</u></p> <p>Indicates that removing the safety and operating the sewing machine for some other purposes with power-on are prohibited.</p> <ul style="list-style-type: none"> ● Please do not operate the sewing machine without protective equipment such as a needle guard, an eye guard, a belt cover or the others. ● Please turn off the power switch when threading, changing a needle and a bobbin, cleaning, and lubricating.
2		<p><u>Caution for fingers injury:</u></p> <p>Indicates a possibility of fingers (hands) injury in a certain condition.</p>
3		<p><u>Caution for squeezing fingers:</u></p> <p>Indicates a possibility of squeezing fingers in a certain condition.</p>

SAFETY PRECAUTIONS



To prevent from receiving an electric shock, always turn off a power switch and unplug power supply when opening a control box, and then open after ten minutes passes.



USAGE ENVIRONMENT

Please do not operate the sewing machine under the following conditions.

- (1) In the ambient temperature of 35 degrees (95°F) or more than 35 degrees, or the ambient temperature of 5 degrees or less than 5 degrees (41°F).
- (2) In the ambient temperature of 55 degrees (131°F) or more than 55 degrees, or the ambient temperature of -10 degrees or less than -10 degrees (18°F) during transportation.
- (3) In the relative humidity exceeding 85% or less than 45%.
- (4) In the open-air place or the location that receives direct sunlight.
- (5) In the place near heat sources such as heating devices.
- (6) In the atmosphere filled with dust, explosive gas, or corrosive gas.
- (7) In the place where the fluctuation in the power voltage of 10% or more than 10%, or the power voltage of -10% or less than -10% of the fixed power voltage.
- (8) In the place where the power source cannot supply enough voltage to keep the motor running.
- (9) In the place filled with strong electric noises such as high-frequency welders.

INSTALLATION

- (1) Please have some specialists, who have enough experience for the sewing machine installations, install the sewing machine.
- (2) Please have a qualified electrician perform necessary electric wiring.
- (3) Please do not operate until the sewing machine is repaired when any damage or fault is found on the sewing machine at the installation.
- (4) Please do not refurbish the sewing machine.
- (5) The sewing machine is heavy. For the safety, please make sure to install the sewing machine head by more than one person.
- (6) Please make sure to fit the safety protective equipment (the motor cover or the others) and the accessory protective equipment (the eye guard) that removed temporarily for installation.

SEWING

- (1) Please make sure to turn the power switch off before installing or replacing needles.
- (2) Please pay attention for the fingers not to be injured by the needle point.
- (3) Please make sure to turn power switch off before lubricating.
- (4) Please pay attention that oil does not get on your skin or in your eyes as it may cause an inflammation.
- (5) Please make sure to keep oil out of the reach of children who may drink oil by mistake.
- (6) Please make sure to turn the power switch off before threading a needle.
- (7) Before starting the sewing, please make sure the position and the function of the halt switch.
- (8) Please do not touch the operating parts during sewing operation.
- (9) It is very dangerous to operate the sewing machine without safety guards (eye guards, belt covers, link covers, finger guards or the others).
Please make sure to operate the sewing machine with safety guards.
- (10) Please make sure to turn the power switch off when stopping the sewing machine temporarily.

ADJUSTMENT

- (1) Please make sure to turn the power switch off before adjusting the sewing machine.
- (2) If the adjustment is required while the power switch on, do not step on the foot switch by mistake.
- (3) Please be careful not to be injured by a sharp part such as the needle and the shuttle hook point.
- (4) Please make sure to put the safety guards (eye guards, belt guards, link covers, and finger guards or the others) back on the initial position after the sewing machine adjustment.

CONTENTS

1. STRUCTURE OF THE SEWING MACHINE	1
2. SPECIFICATIONS	2
3. INSTALLATION	3
3-1. Installation of the foot switch	3
3-2. Connection of the air tube	4
3-3. Installation of the thread stand	4
3-4. Installation of the eye guard	5
3-5. Installation of the rubber cushion	5
4. LUBRICATION	6
4-1. Filling the oil tank	6
5. PROPER OPERATION	7
5-1. Installation of the needles	7
5-2. Threading the needle thread	8
5-3. Winding the bobbin thread	9
5-4. How to opening the bobbin access door	10
5-5. Setting the bobbin	11
5-6. Setting the bobbin case	11
5-7. How to operating the jig eject system	12
5-8. Operation of the halt switch	13
5-9. Adjustment of the thread tension	14
5-10. Adjustment of upper thread tension	14
6. STANDARD ADJUSTMENT	15
6-1. Adjustment of the needle bar position	15
6-2. Adjustment of the position between the needle and the shuttle hook	16
6-2-1. How to remove the sliding plate	16
6-2-2. Adjustment of the driver position	17
6-2-3. Adjustment of the clearance between the shuttle hook and the needle	19
6-2-4. Adjustment of the clearance between the driver and the needle	21
6-2-5. Adjustment of the shuttle race thread guide	22
6-2-6. Adjustment of the timing between the hook and the needle motion	23
6-4. Adjustment of the oil lubrication	26
6-5. Setting of the pressor foot movement	27

6-6. Adjustment of the wiper	24
6-7. Adjustment of the thread take up spring	25
6-7-1. Adjusting movable range of the thread take up spring	25
6-7-2. Adjusting intensity of the thread take up spring	25
6-8. Adjustment of the thread tail after the trimming	26
6-9 Adjustment of the air pressure	26
7. VARIOS ADJUSTMENT	30
7-1. How to exchanging the tension spring of the needle thread tensioner unit	30
7-2. Adjustment of the detector position of the presser foot unit	32
7-3. How to replace with a special pressor foot	35
7-4. Adjustment of the pressor foot holder position	38
7-5. Adjustment of the thread trimmer	39
7-5-1. Adjustment of the movable knife	39
7-5-2. Adjustment of the fixed knife	40
7-5-3. Adjustment of the trimmer cam detector position	41
7-6. How to remove the XY cover	42
7-7. Adjustment of the XY table detector	43
7-7-1. Adjustment of X direction	44
7-7-2. Adjustment of Y direction	45
7-8. Adjustment of the Y timing belt tension	46
8. MAINTENANCE	47
8-1. Cleaning	47
8-2. Greasing	47
8-3. Disposing of oil waste	49
9. TROUBLESHOOTING	50
10. APPENDIX	
10-1. The positional relationship between the sewing area and jig eject system	
10-2. Air piping drawing	

1. STRUCTURE OF THE SEWING MACHINE

PLK-J4040 Industrial sewing machine consists of the following main parts.

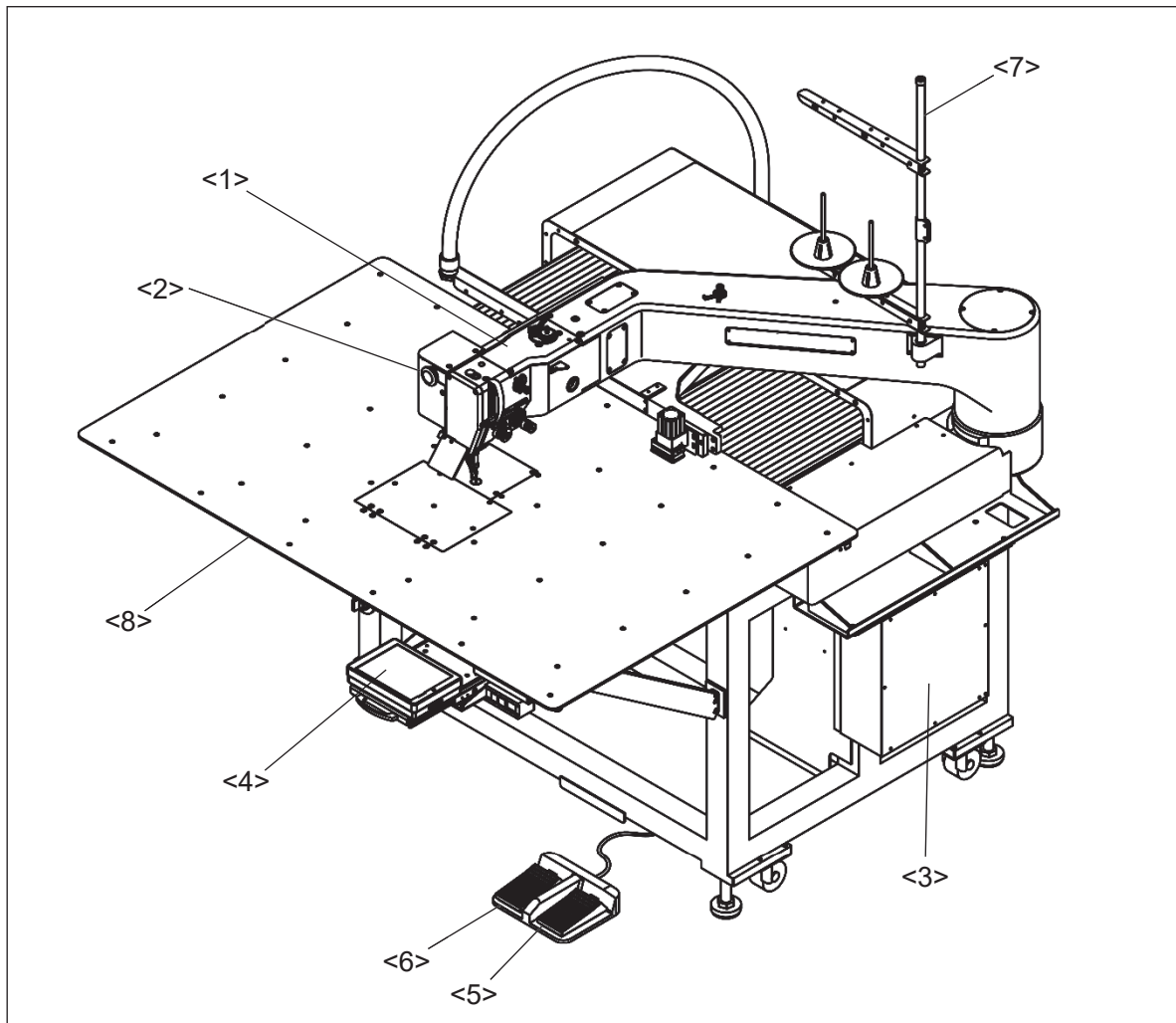

<1>: Sewing machine head <2>: Halt switch <3>: Control box <4>: Operation panel
<5>: Work holder switch <6>: Start switch <7>: Thread stand <8>: Sewing machine table

2. SPECIFICATIONS

Model	PLK-J4040
Stitch type	Single needle lock stitch
Hook	Large size shuttle hook
Class of needle	DPX17#18
Sewing area	X-direction (left/right) 400 mm
	Y-direction (front / back) 400 mm
Maximum sewing speed *1	2,000rpm (Continuous feeding) 2,000rpm (M3 feeding)
Maximum sewing speed	10 speed levels in 200 rpm to 2,000 rpm (M3 feeding)
Stitch length	0.1 to 20.0 mm (min. resolution 0.1 mm)
Maximum number of needles	20,000 per pattern
Storable sewing data item	9,000 patterns *2
Data memory	USB memory
Type of motor (Needle side)	750W direct servo motor
Type of motor (Hook side)	400W direct servo motor
Work holder	Jig eject system
Needle bar stroke	41.2 mm
Thread take up lever stroke	68.0 mm
Presser foot drive	Direct drive by stepping motor
Presser foot lift	18.0 mm (max. 24.0 mm) Variable in 0.1 mm step
Presser foot stroke	Digital adjustment stroke: 0.1 to 10.0 mm
Upper thread tensioner	Manual / automatic / Setting on pattern (switchover)
Wiper system	Back to front wiping system
Oil lubrication	Spray method: Spray time adjustment
Operation panel	6.5-inch color LCD touch panel with USB port
External device I/F	USB port, Terminal I/O: 16 input, 16 output
Thread trimmer system	Horizontal engagement with fixed knife and movable knife
Machine dimensions (W)x(L)x(H)	1,350mm x 1,570mm x1,205mm
Weight	440kg
Power	In 200V to 240V single-phase or three-phase

*1: Sewing speed may be limited by the operation or sewing condition.

*2: The max. patterns may be limited depending on the number of stitches of each pattern in the memory.

*3: Standard value is 8.0 mm.

3. INSTALLATION



- (1) Please have some specialists, who have enough experience for the sewing machine installations, install the sewing machine.
- (2) Please have a Qualified Electrician perform necessary electric wiring.
- (3) Please do not operate until the sewing machine is repaired when any damage or fault is found on the sewing machine at the installation.
- (4) Please do not refurbish the sewing machine.

3-1. Installation of the foot switch

Connect the foot switch to the connector CON L. The foot switch is enclosed in the accessory box.

NOTE Refer to the instructions in the paragraph "[4] Name of each part, wiring and grounding" in the **CONTROL UNIT** technical manual.

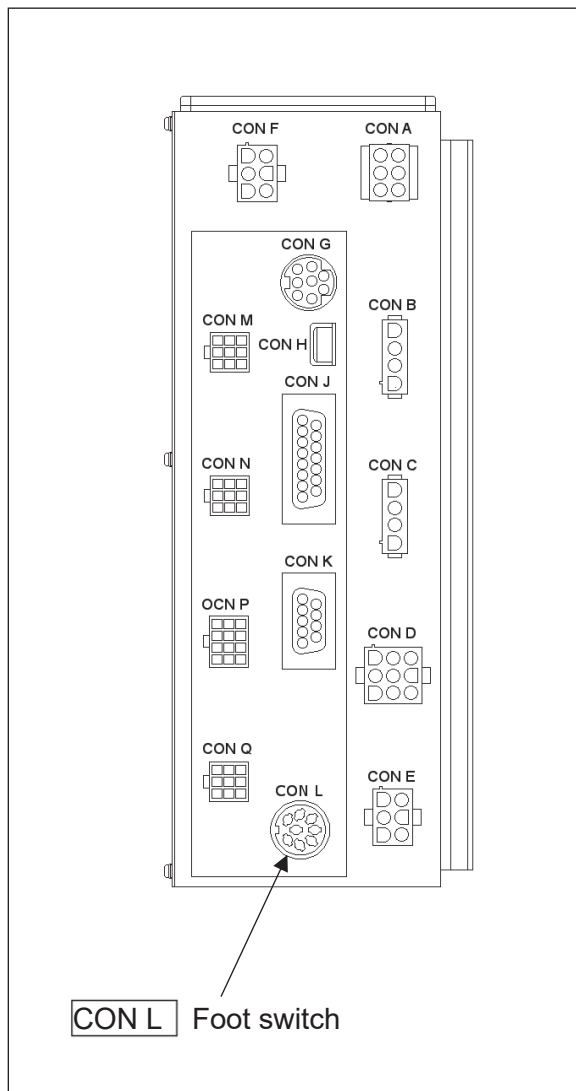

3-2. Connection of the air tube

Insert the one end of the air tube (8mm Diameter) into the intake air fitting (No.3) of the filter regulator (No.2) then, join the other end of the air tube with the suitable air coupling to be adopted with the air supply source provided in your factory. One of the air couplings (No.4) is enclosed in the accessory box.

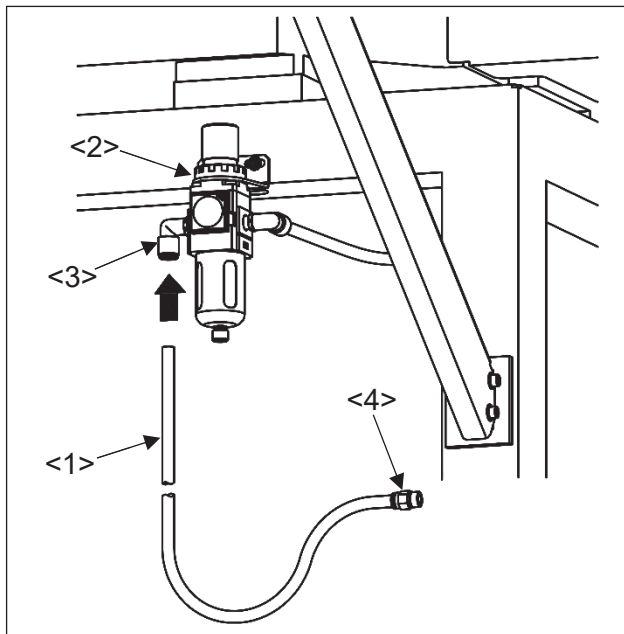

- <1>: Air tube (8mm Diameter)
- <2>: Filter regulator
- <3>: Intake air fitting
- <4>: Air coupling

3-3. Installation of the thread stand

(1) Assemble the parts of the thread stand as shown on the figure.

(2) Fit the thread stand into the hole at the far right on the machine arm with the nut (No.14) and the washer (No.12) and cushion (No.13).

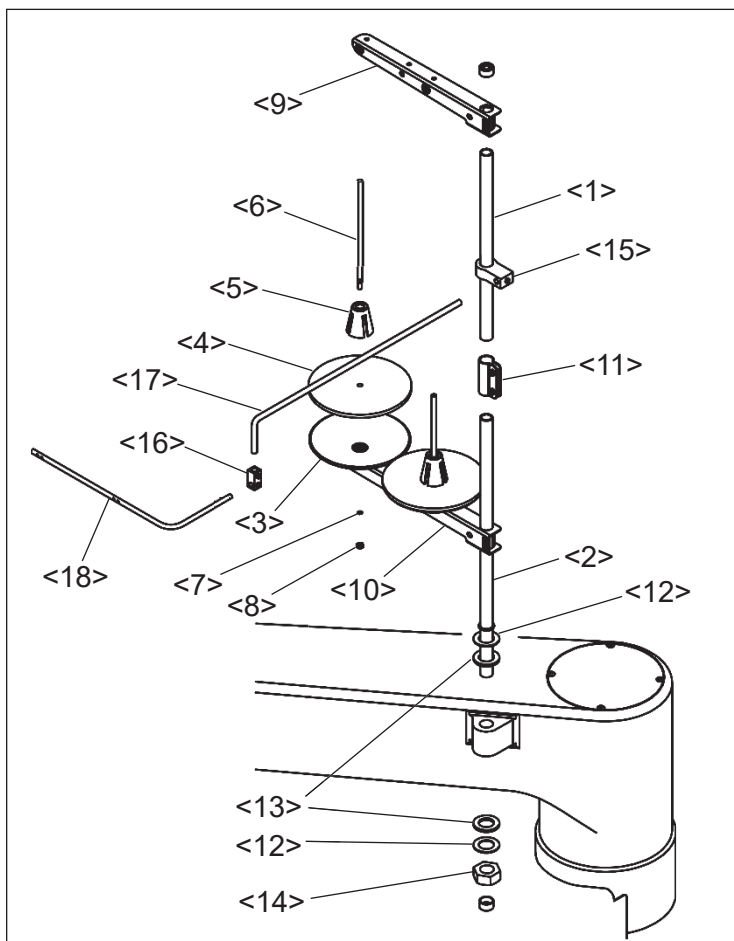

- <1>: Upper column pipe
- <2>: Lower column pipe
- <3>: Spool stand base
- <4>: Spool mat
- <5>: Spool holder
- <6>: Spool shaft
- <7>: Spring washer
- <8>: Nut
- <9>: Thread hunger
- <10>: Spool holder
- <11>: Column joint
- <12>: Washer
- <13>: Cushion
- <14>: Nut
- <15>: Bracket (large)
- <16>: Bracket (small)
- <17>: Holder
- <18>: Thread guide

3-4. Installation of the eye guard

(1) Mount the eye guard (No.1) with screw (No.2) to sewing machine head.

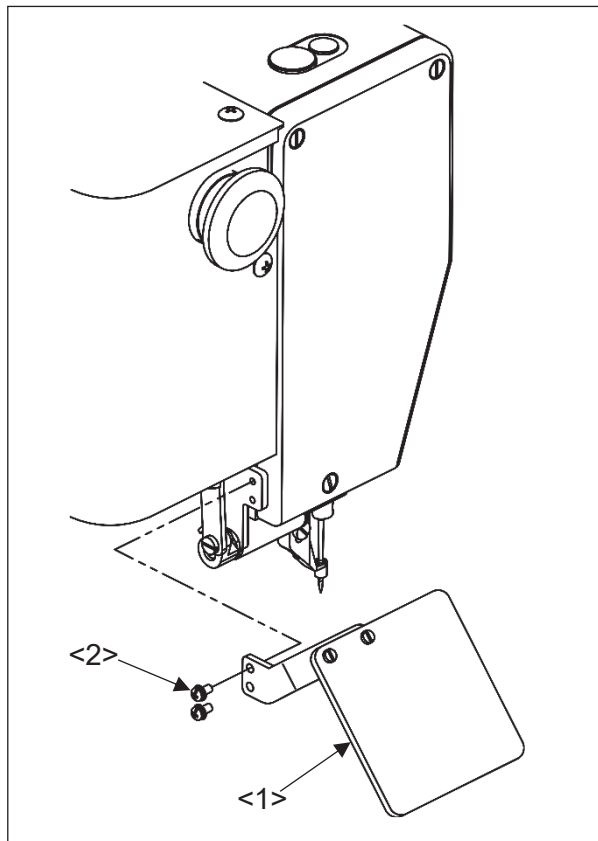

<1>: Eye guard unit

<2>: Screw

3-5. Installation of the rubber cushion

(1) Screw the adjust foot (No.2) in the direction of "a" arrow and locate the rubber cushion (No.1) between the adjust foot and floor which included in accessory box. For the other three rubber cushions, the procedure is same.

(2) Screw the adjust foot (No.2) in the direction of "b" arrow and adjust the adjust foot height so that the each hour caster (No.3) is to be raised from the floor by several millimeters. After adjustment please check if there is no inclination about the machine table.

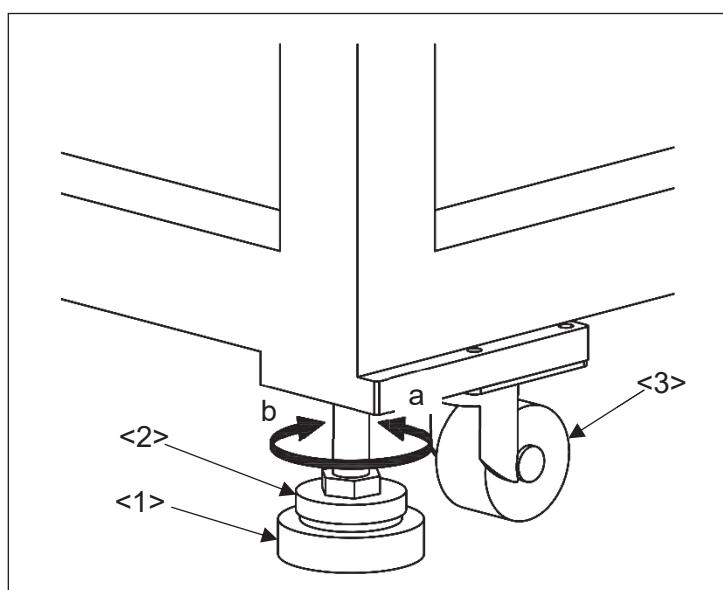

<1>: Rubber cushion

<2>: Adjust foot

<3>: Caster

4. LUBRICATION



- (1) Please make sure to turn power switch off before lubricating.
- (2) Please pay attention that oil does not get on your skin or in your eyes as it may cause an inflammation.
- (3) Please make sure to keep oil out of the reach of children who may drink oil by mistake.

NOTICE Please make sure to lubricate when operating for the first time after the installation. Also, please make sure to check the amount of oil when the machine has not been used for a long time.

4-1. Filling the oil tank

Pour the oil through the oil hole (No.1) to the oil tank (No.2) on the machine arm. Pour the oil through the oil hole (No.3) which has machine table to the oil tank (No.4). Please fill with the oil over level mark (No.5) of the oil tank.

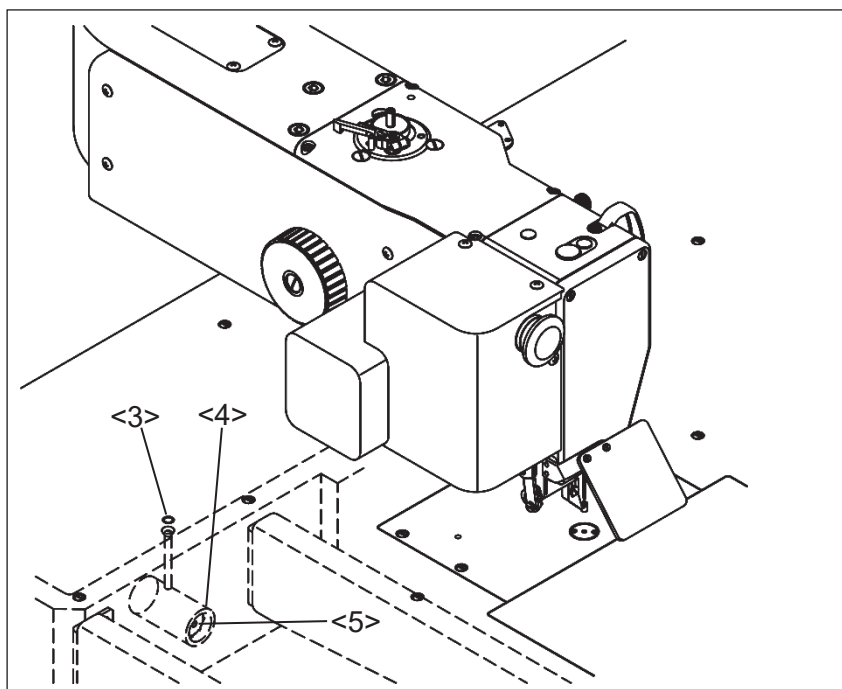
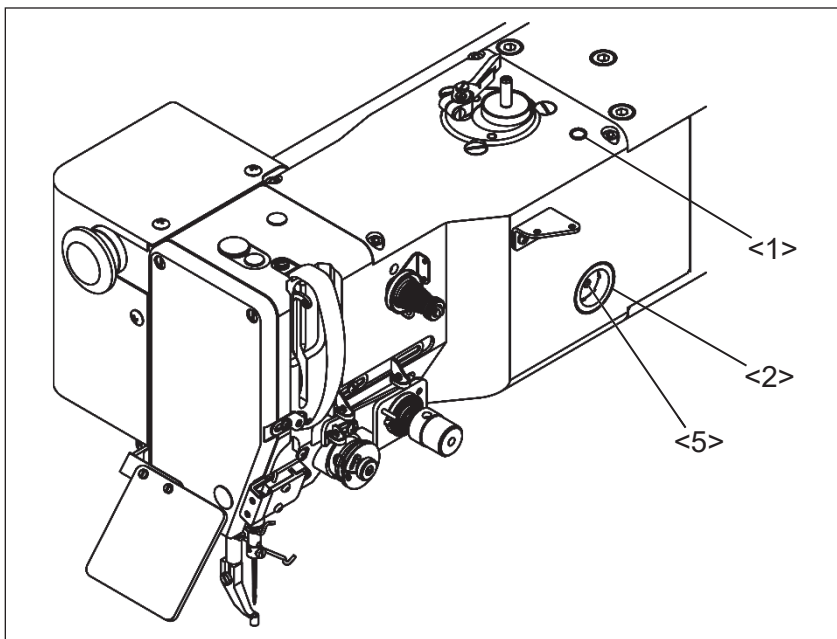

5. PROPER OPERATION

5-1. Installation of the needle



(1) Please make sure to turn the power switch off before installing or replacing needles.

(2) Please pay attention for the fingers not to be injured by the needle point.

(1) Loosen the set screw (No.1) then, insert a new needle (No.2) until the needle head is reached the end of the hole of the needle bar (No.3).

(2) Tighten the set screw (No.1) with facing the needle groove (No.4) to the front.

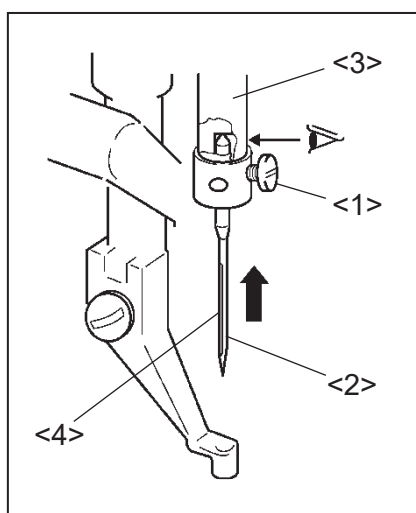

<1>: Set screw

<2>: Needle

<3>: Needle bar

<4>: Needle groove

5-2. Threading the needle thread



(1) Please turn the power switch off when threading a needle.

(1) Thread the needle thread as shown on the figure.

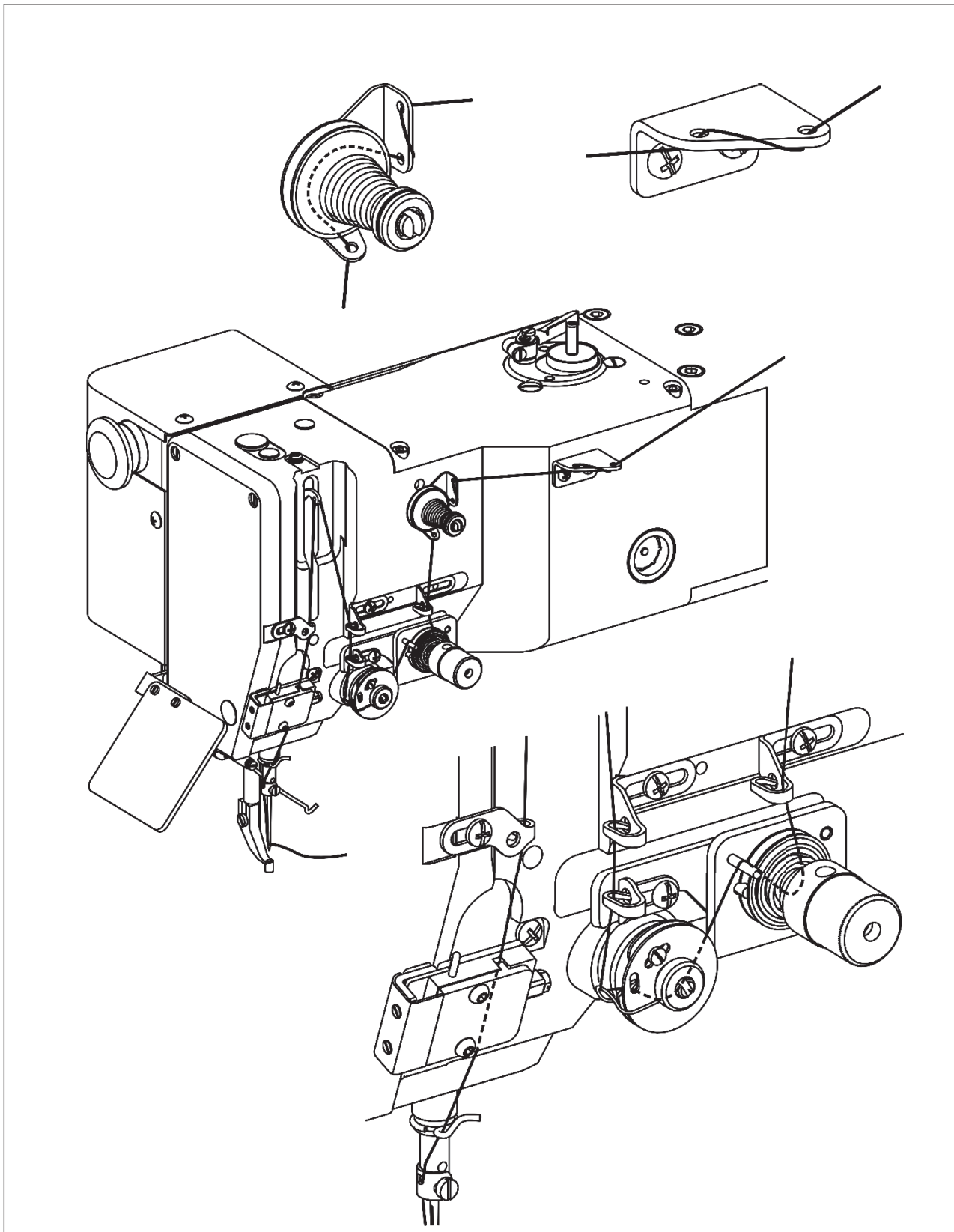

5-3. Winding the bobbin thread



CAUTION

(1) Please do not touch the rotating part during winding thread. Doing so may cause injury and/or the machine failure.

NOTICE Please make sure to pull the upper thread out of the needle before winding the bobbin thread.

- (1) Route the thread as shown in the below figure then, wind the thread to the bobbin (No.1) in the direction of "a" arrow several times. Then fit the bobbin to the bobbin winder (No.2) and push in the bobbin presser arm (No.3).
- (2) With the machine in the Bobbin Wind Mode, step on the work holder foot switch first and then the start switch second so that the thread continues winding to the bobbin while the start switch is stepped on.
- (3) When the bobbin finishes winding a certain amount (80 to 90 % of the outside diameter of bobbin) of thread, the bobbin presser arm is returned to the initial position. Adjust the amount of the winding thread with the subsidiary arm (No.4).
- (4) To wind the bobbin thread during the sewing operation, carry out the procedure (1) above then, the bobbin winding is performed automatically.

For the bobbin winding mode, refer to the instructions in the paragraph "[3] Explanations of basic screen, icons and operation "7. The Bobbin Winding screen" is explained below" in the

OPERATION PANEL technical manual.

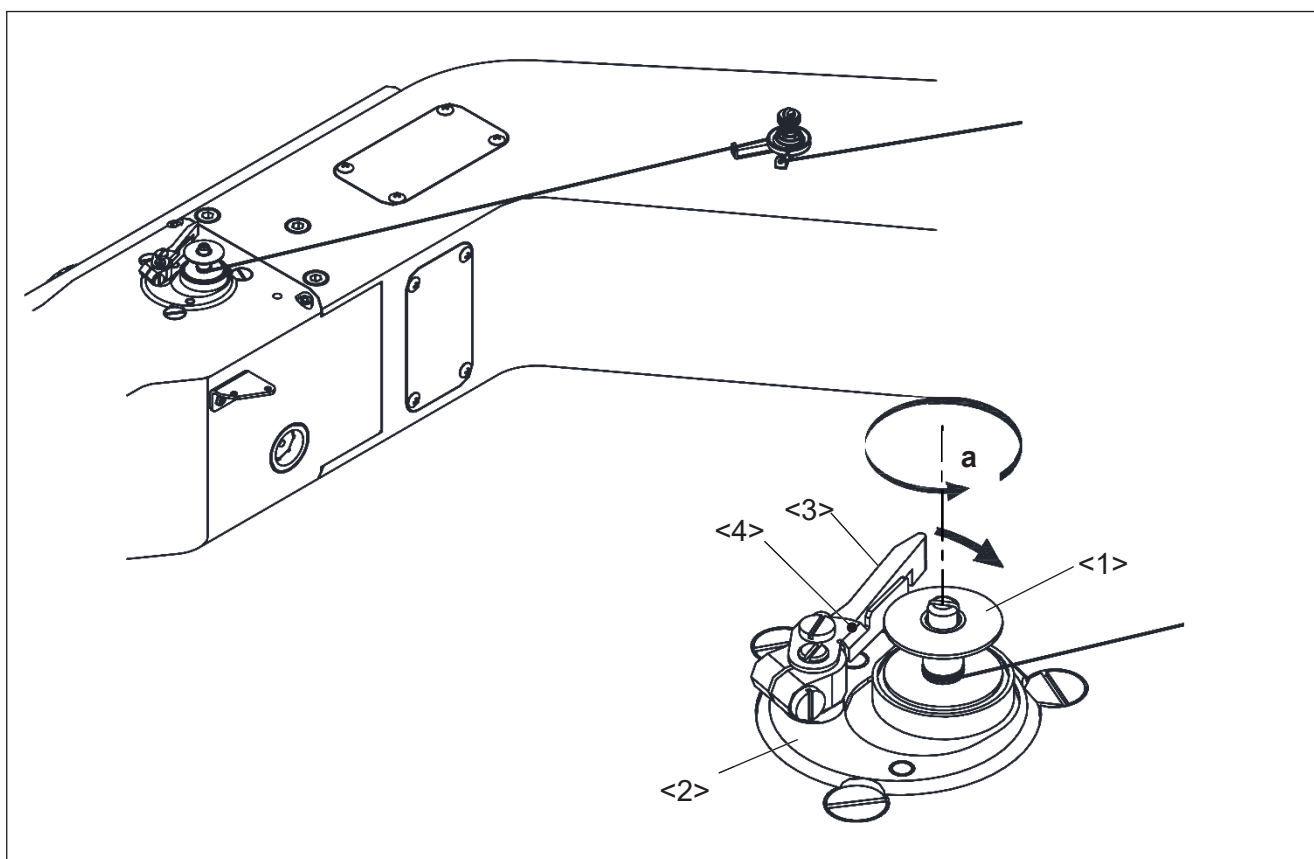

<1>: Bobbin <2>: Bobbin winder <3>: Bobbin presser arm <4>: Subsidiary arm

5-4.How to opening the bobbin access door

When exchanging the bobbin, please open the bobbin access door (No.1) referring the following paragraph.
The bobbin access door has center of the machine table.

(1) Turn the opening switch (No.2) in the direction of the arrow which has front lower side of the table. The bobbin access door opens when opening switch (No.2) becomes state in showing in below figure.

(2) When closing the bobbin access door (No.1), turn the opening switch (No.2) in the opposite direction from state in .

NOTE When start the sewing unless the bobbin access door (No.1) is opened, the start prohibition signal is valid.

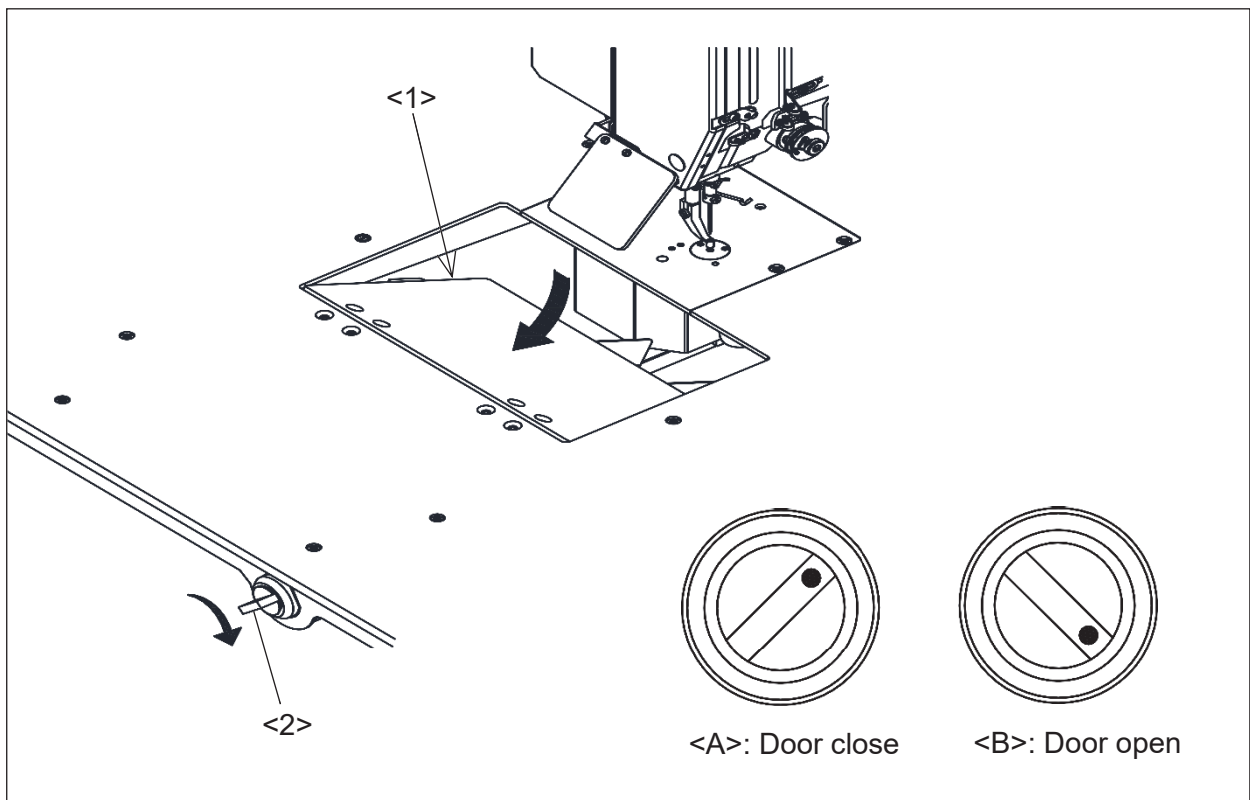

<1>: Bobbin access door <2>: Opening switch

5-5. Setting the bobbin

(1) Set the bobbin (No.2) into the bobbin case (No.1).

(2) Pull the bobbin thread (No.3) into the slit (No.4) and pass through the thread hole (No.5).

At this time, pull the bobbin thread (No.3) then, check with the bobbin (No.2) if it is rotated to the arrow direction. If it is not, set the bobbin (No.2) into the bobbin case (No.1) over again to get the proper rotation.

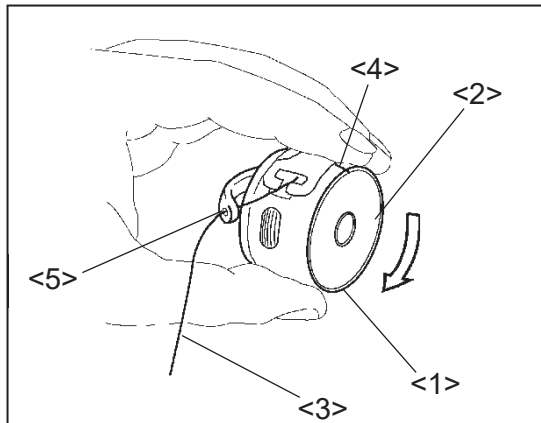

- <1>: Bobbin case
- <2>: Bobbin
- <3>: Thread
- <4>: Bobbin case slit
- <5>: Bobbin case thread hole

5-6. Setting the bobbin case

(1) Pull the bobbin thread about 25mm out of the thread hole of the bobbin case (No.1).

(2) Open the bobbin access door.

(3) Open the bobbin case latch (No.2) and hold it then, fit it securely in the shuttle hook (No.3).

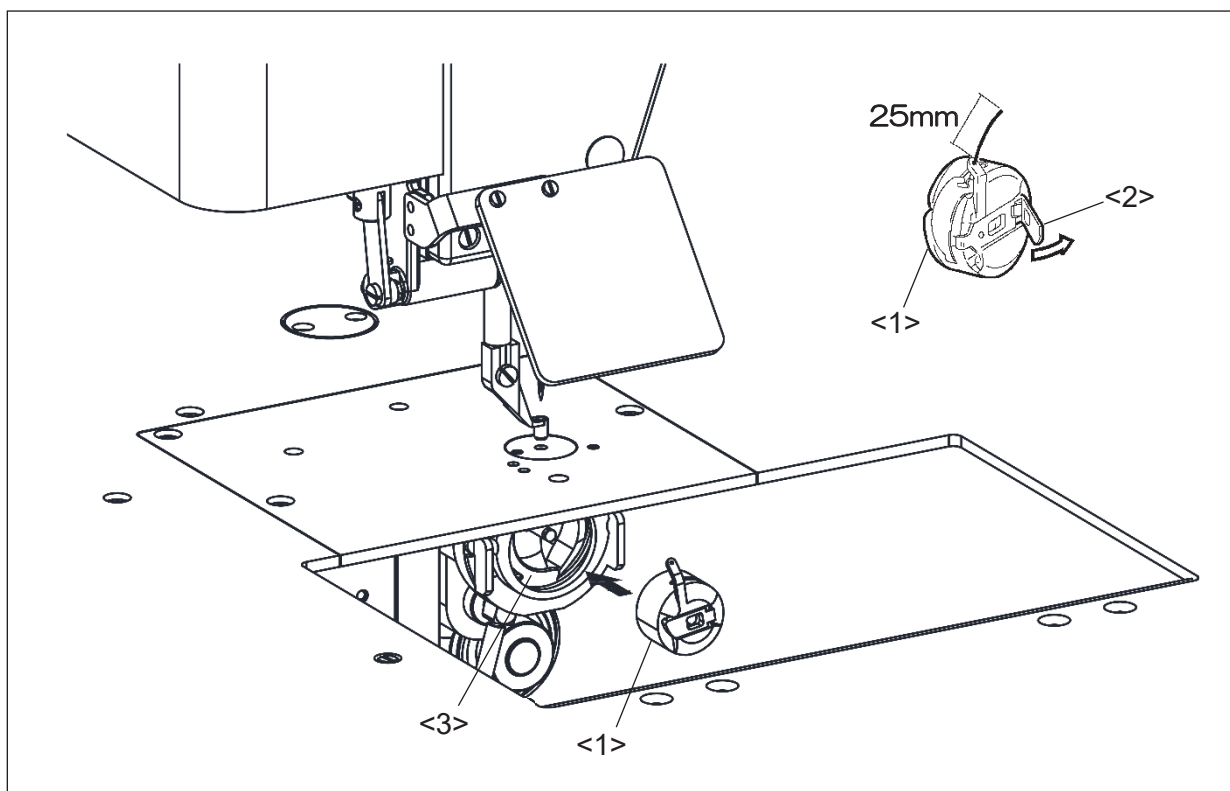

- <1>: Bobbin case
- <2>: Bobbin case latch
- <3>: Shuttle hook

5-7. How to operating the jig eject system

(1) Prepare the type of the work holder for jig eject system, and install the cassette jig right (No.1) and cassette jig left (No.2) which are enclosed in accessory box.

NOTE For more information concerning about dimension, please refer to the last chapter <10-1.>.

(2) Install the cassette jig right (No.1) and cassette jig left (No.2) to the inmost part of the each jig eject system (No.3).

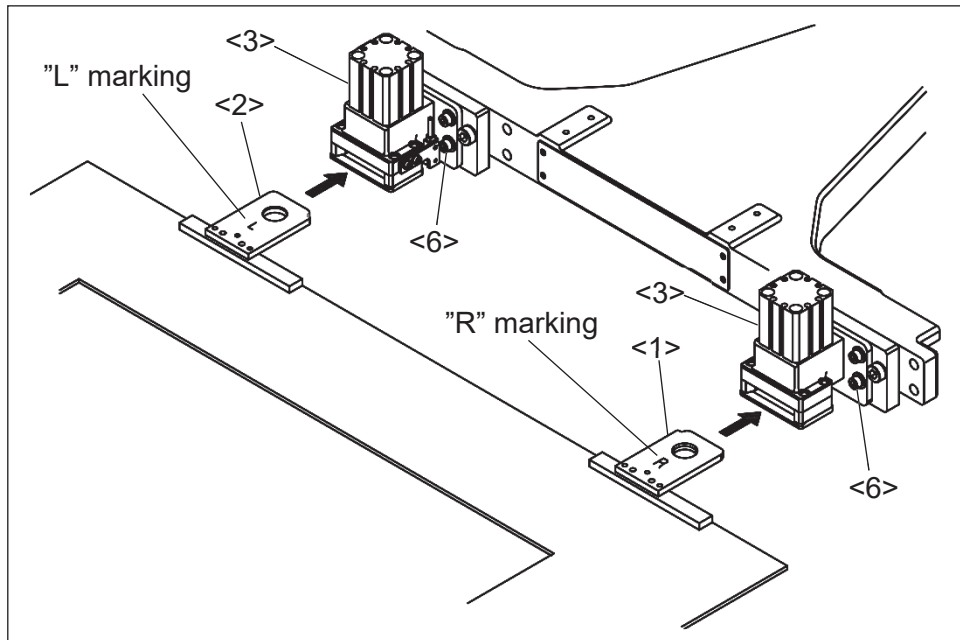

<1>: Cassette jig right <2>: Cassette jig left <3>: Jig eject system
 <6>: Jig eject system install screw

(3) Step on the work holder (black colored) foot pedal. The work holder become fixed when both of locate pin (No.4) which has each jig eject system actuated. Please make sure if the work holder is fixed securely after step on the foot pedal. The work holder is not fixed due to the insufficient actuation of locate pin (No.4) when either or both cassette jig are not installed enough.

NOTE Please make sure if the bottom surface of cassette jig (A) and lower plate (No.5) are in same level. If different, loosen the each four of Jig eject system install screws (No.6) and adjust the jig eject system (No.3) height.

NOTICE Please note that the lower plate (No.5) does not touch directly to the slide plate.

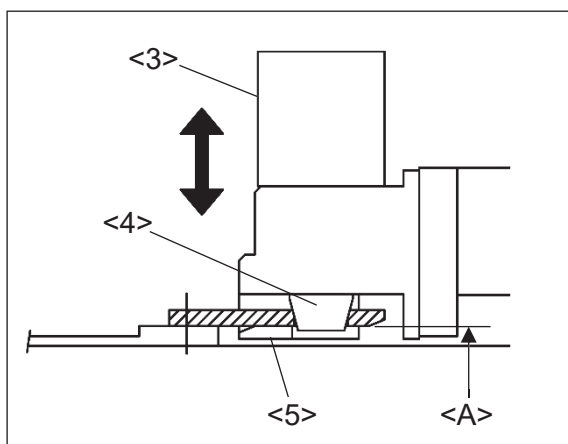

<3>: Jig eject system
 <4>: Locate pin
 <5>: Lower plate
 <A>: Bottom surface of cassette jig

5-8. Operation of the halt switch

- (1) If accidents such as a thread breakage, needle breakage and others happened during the sewing, press the halt switch immediately. The sewing machine stops instantly.
- (2) To cancel the halt state, press the halt switch again.
- (3) When continuing sewing, step on the grey foot switch to restart at the halted position. (Press the jogging in forward/reverse direction icon so that the sewing start position will move.)
- (4) To cancel sewing, press the home position return icon .

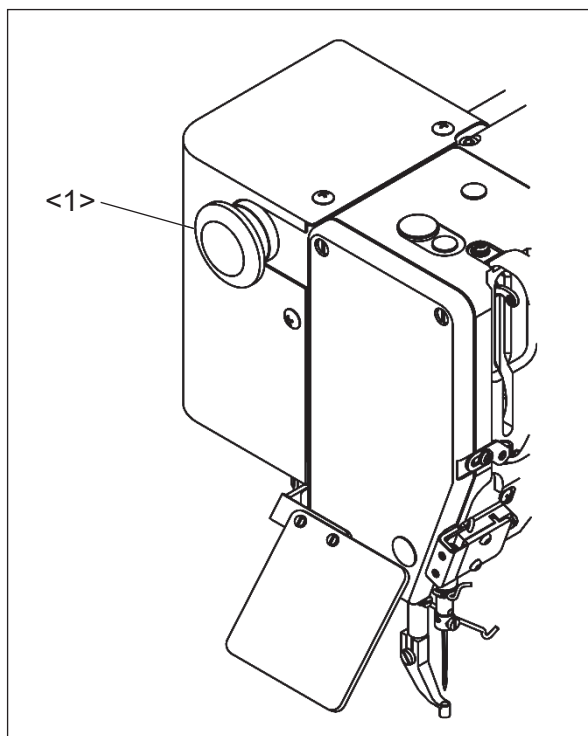

<1>: Halt switch

5-9. Adjustment of the thread tension

(1) Adjust the bobbin thread tension with the thread tension adjusting screw (No.2) on the bobbin case (No.1). The thread tension become loose if turn the thread tension adjusting screw (No.2) to the counterclockwise, and the thread tension becomes tight if turn it to the clockwise.

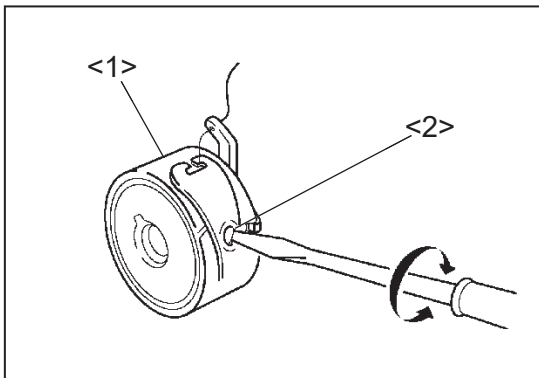

<1>: Bobbin case
<2>: Adjusting screw

5-10. Adjustment of upper thread tension

Adjust the upper thread tension corresponding to the bobbin thread tension. The upper thread tension becomes tight when tightening the thread tension adjusting nut (No.1) clockwise, and the upper thread tension becomes loose when loosening the thread tension adjusting nut counterclockwise.

NOTE It is possible to adjust the upper thread tension automatically. Please refer to the instructions **OPERATION PANEL** technical manual concerning about [Digital tension].

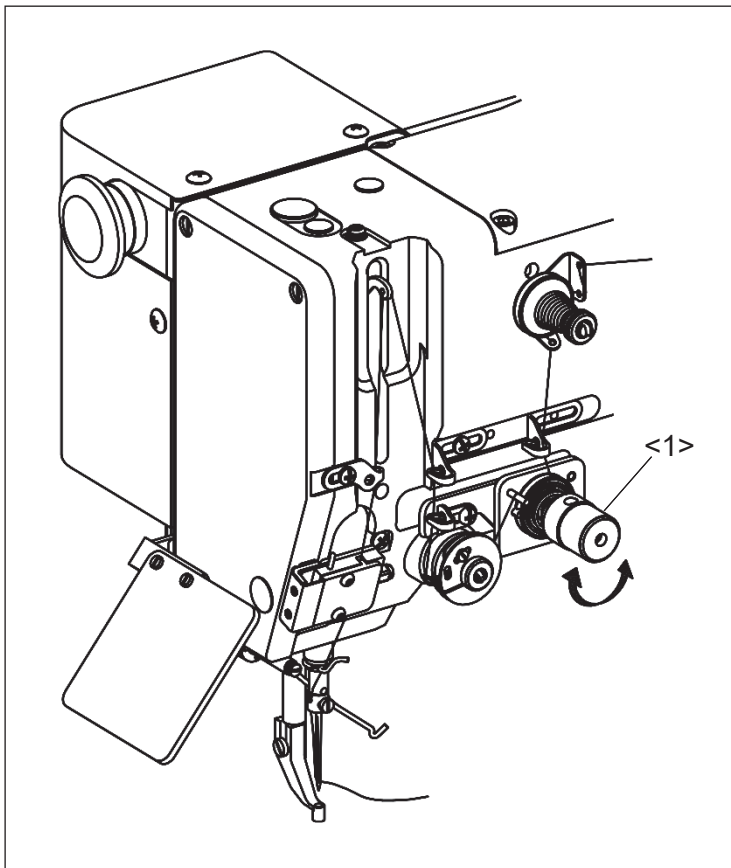

<1>: Thread tension adjusting nut

6. STANDARD ADJUSTMENT



CAUTION

- (1) Please make sure to turn the power switch off before adjusting the sewing machine.
- (2) When adjusting the sewing machine with the power switch on, please be careful not to step on the foot switch by mistake.
- (3) Please be careful not to be injured by a sharp part such as the needle and the hook point.
- (4) Please make sure to put the safety guards (eye guards, link covers, and finger guards or the others) back on the initial position after the sewing machine adjustment.

6-1. Adjustment of the needle bar position

(1) Turn the power switch off and remove the needle then, stop the needle bar (No.1) at the lowest position.

NOTE The needle shaft and the hook shaft are controlled by synchronous operation only when the power switch is on. In this reason, there is a risk that the needle may collide with hook when down the needle bar without removing the needle.

(2) Move the needle bar (No.1) to the position where the needle bar timing mark A is matched to the needle bar bushing (No.2) bottom line. (For the needle class DP × 17)

(3) If the position of the needle bar timing mark A is not matched to the needle bar bushing bottom line, remove the rubber plug (No.3) from the face cover then, loosen the needle bar holder set screw (No.4).

(4) For the needle class DP×5, move the needle bar to the position where the needle bar timing mark B is matched to the needle bar bushing (No.2) bottom line.

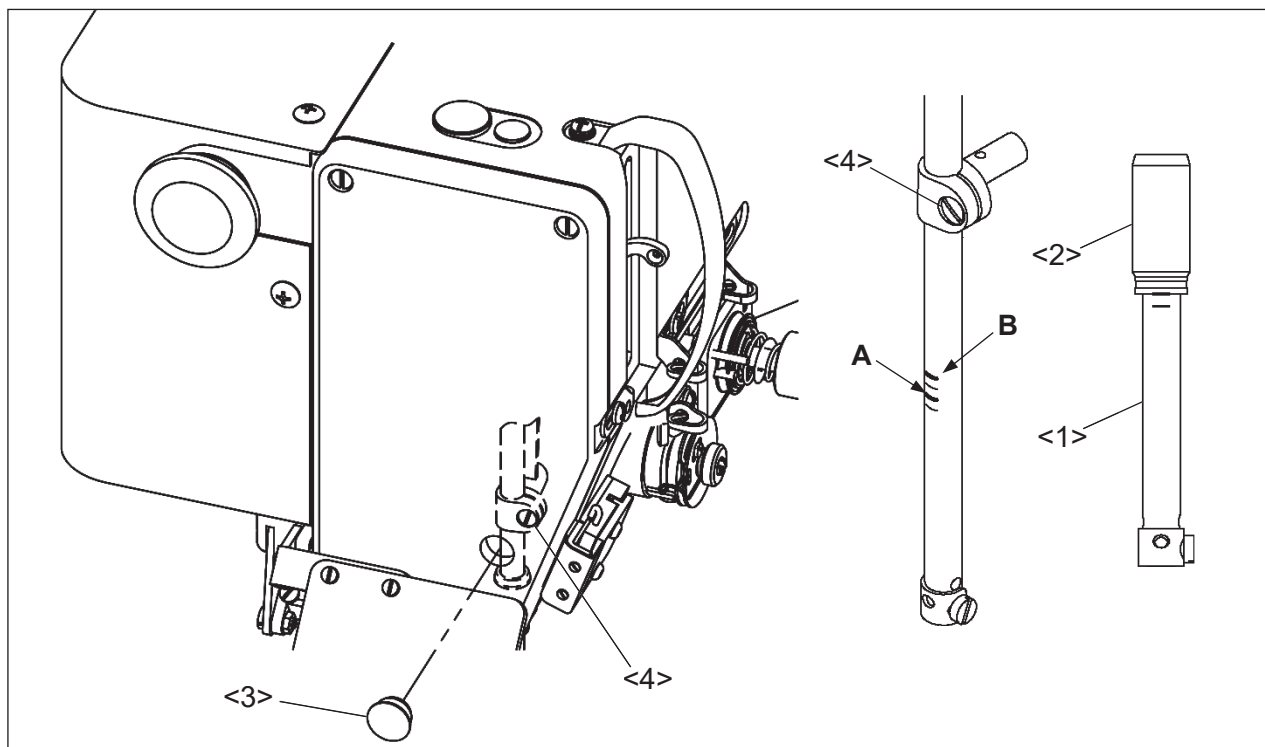

<1>: Needle bar <2>: Needle bar bushing <3>: Rubber plug <4>: Needle bar holder set screw

Timing mark A: For the needle class DP×17

Timing mark B: For the needle class DP×5

6-2. Adjustment of the position between the needle and the shuttle hook

6-2-1. How to remove the sliding plate

- (1) Turn the power switch OFF.
- (2) Open the bobbin access door.
- (3) Remove the four screws (No.2) and remove the sliding plate (No.1). In this time, the trimmer link (No.4) is removed from the driving lever (No.3).

NOTE The trimmer lever (No.4) is fitted with drive lever (No.3) by entering the locate pin with drive lever (No.3) into the trimmer lever (No.4) hole. When remove the trimmer lever (No.4), hold the trimmer lever (No.4) by hand as in the below drawing and lift the sliding plate (No.1). The trimmer link (No.4) is removed from the driving lever (No.3) smoothly.

- (4) To entering the locate pin with drive lever (No.3) into the trimmer lever (No.4) hole smoothly, aligning the center of the trimmer link (No.4) hole with the reference hole (No.5) when back the sliding plate (No.1).

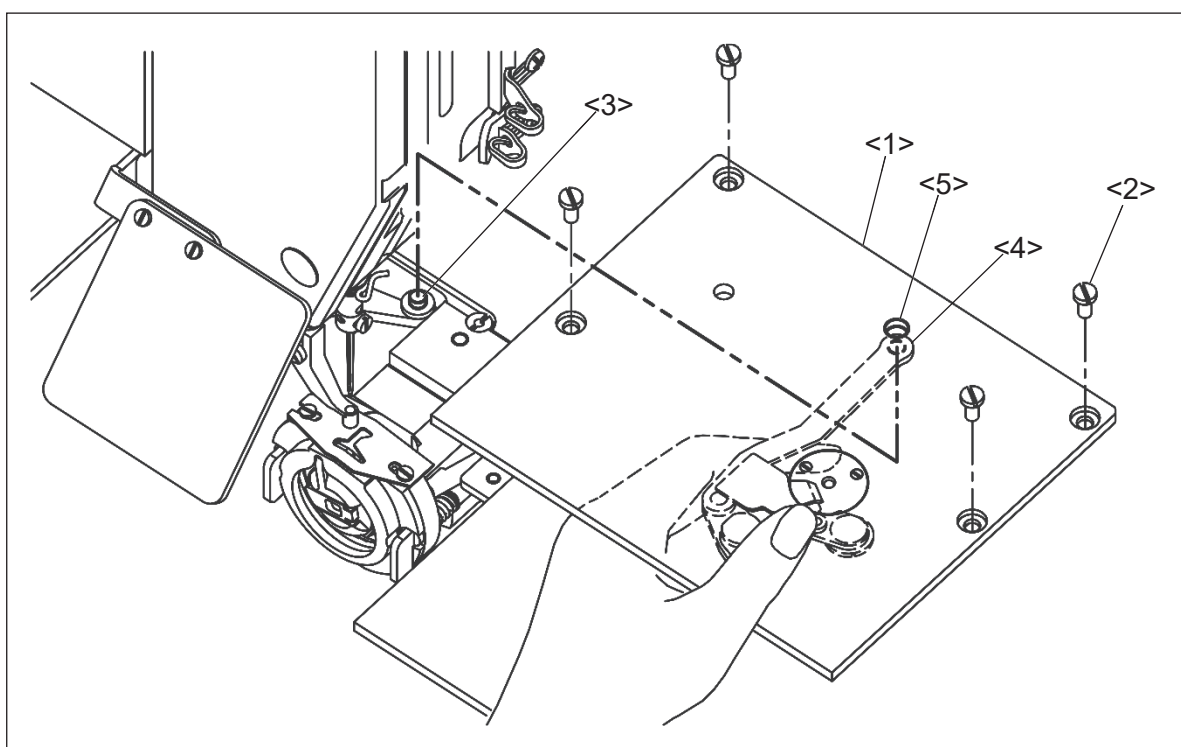

<1>: Sliding plate <2>: Screw <3>: Driving lever <4>: Trimmer lever
<5>: Reference hole

6-2-2. Adjustment of the driver position

- (1) Remove the bobbin case (No.1) and turn the hook retainer arm (No.3) then, remove the hook retainer (No.2).
- (2) Remove the two screws (No.7) and remove the shuttle race thread guide (No.6).
- (3) Taking care not to drop the shuttle hook (No.4), turn the hand pulley for hook shaft (No.5) in the arrow direction. The shuttle hook (No.4) rotates reciprocally.

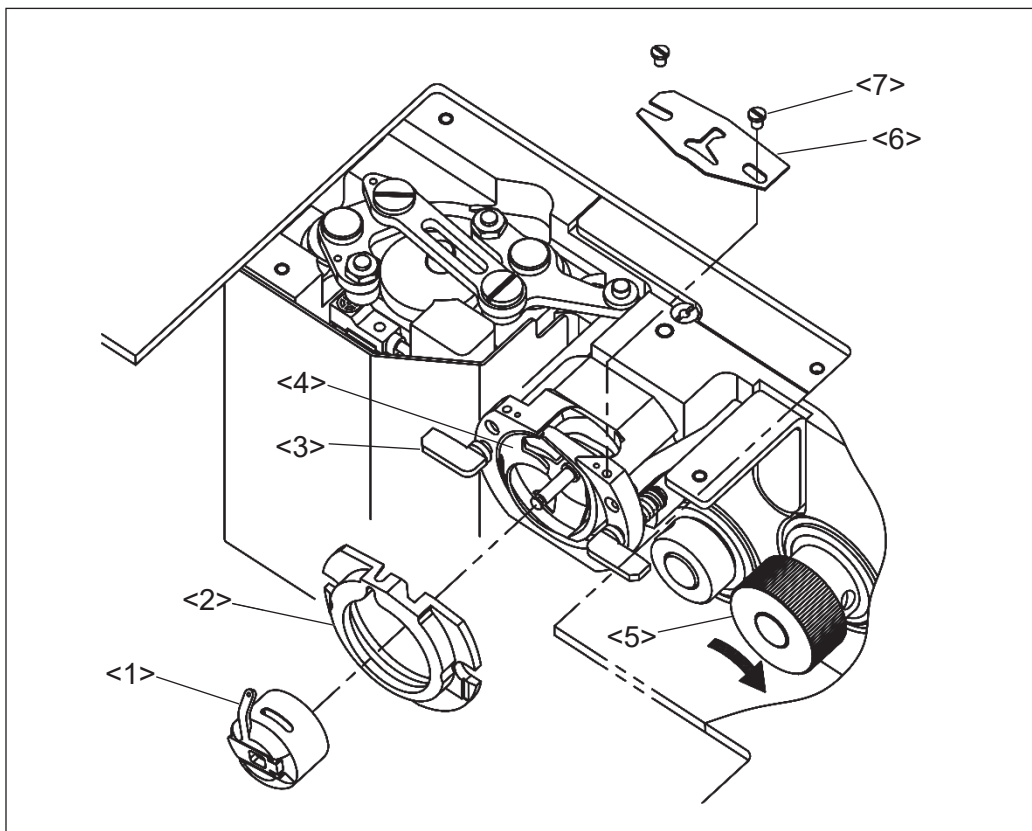

<1>: Bobbin case <2>: Hook retainer <3>: Hook retainer arm <4>: Shuttle hook
<5>: Hand pulley for hook shaft <6>: Shuttle race thread guide <7>: Screw

- (4) By rotating the shuttle hook (No.4) and stop its rotation where the rotate direction changed to clock wise from counter clock wise viewed from the front of the shuttle hook (No.4). In this time, please confirm if the hook edge (No.8) corresponded to the shuttle race end (No.9) as showed in below figure.
- (5) If different, remove the shuttle hook (No.4) and loosen the driver set screw (No.11) with hexagon wrench (No.12) and adjust the driver (No.10) position in the rotating direction. After adjustment tighten the driver set screw (No.11) and reconfirm the hook edge (No.8) position according to above procedures.
- NOTE** Please note that the end of the hook shaft (No.13) does not protrude from driver (No.10) face. In this case, end of the hook shaft (No.13) prevents normal thread passing and it may causes sewing defects.

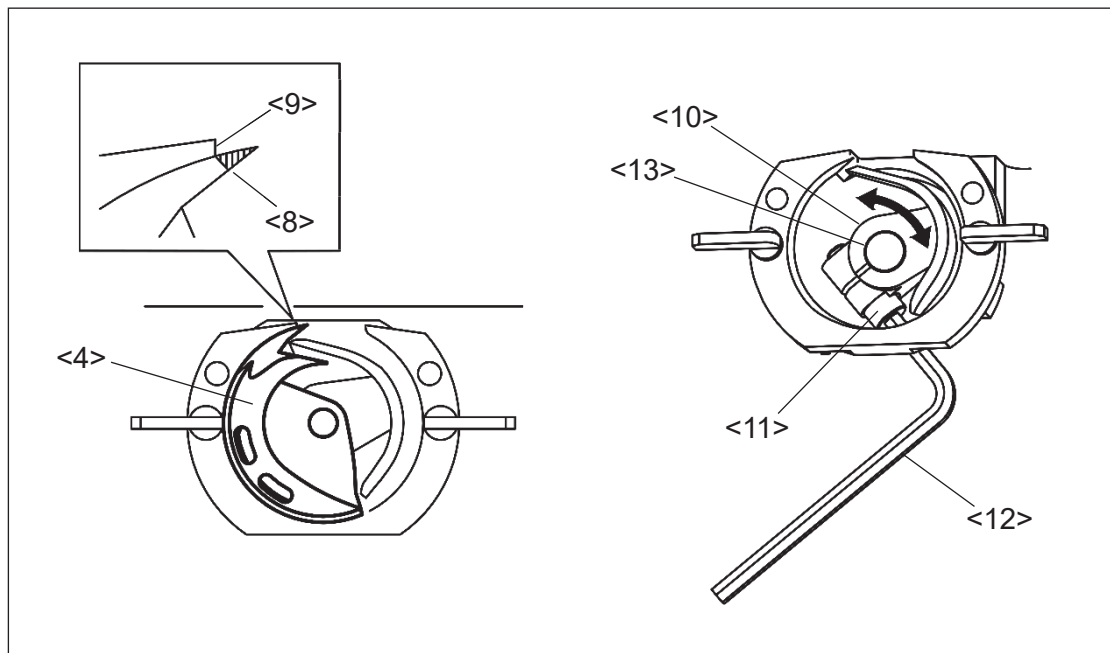

<4>: Shuttle hook <8>: Hook edge <9>: Shuttle race end <10>: Driver
 <11>: Driver set screw <12>: Hexagon wrench <13>: Hook shaft

6-2-3. Adjustment of the clearance between the shuttle hook and the needle

- (1) To prevent the needle collision, please remove the shuttle hook or place the shuttle hook according to the previous paragraph <6-2-2. Adjustment of the driver position>.
- (2) Turn the hand pulley (No.1) by hand in the direction of the arrow then, move up the needle bar (No.2) from the lowest position and stop it at the position where the needle bar timing mark C is matched to the needle bar bushing bottom line (No.3).

NOTE If the needle class is DPx5, match the needle bar timing mark D to the needle bar bushing bottom line (No.3).

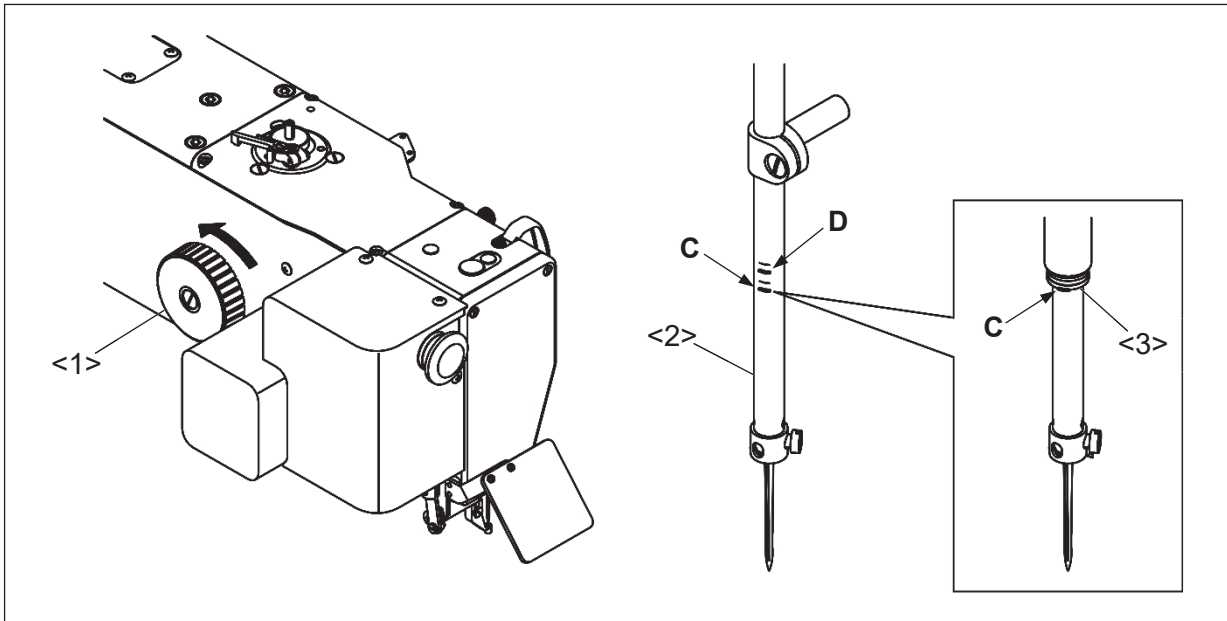

<1>: Hand pulley <2>: Needle bar <3>: Needle bar bushing bottom line

Timing mark C: For the needle class DPx17

Timing mark D: For the needle class DPx5

- (3) Turn the hand pulley (No.1) for hook shaft by hand and stop it at the position where the hook point (No.4) meets with the center line of the needle (No.5).

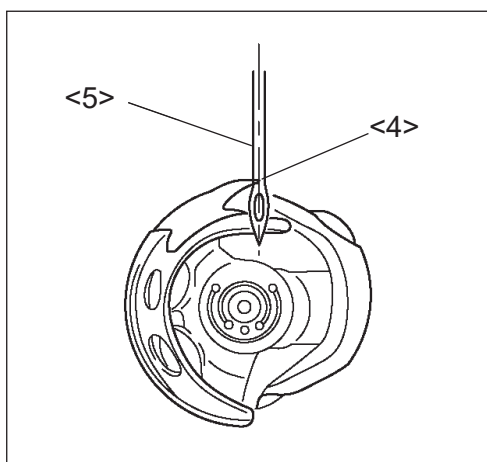

<4>: Hook point

<5>: Needle

- (4) Set the clearance between the shuttle hook point (No.4) and the needle (No.5) in 0.05 to 0.1 mm.
This is the standard position.
- (5) Loosen the shuttle race set screw (No.6) and turn the eccentric pin (No.7) to move the hook back and forth for adjustment. Adjust the clearance to be standard, and tighten set screw (No.6). (*1)
- (6) After adjusting, move up the needle (No.5) and check that the pulley can be turned lightly by hand.
- *1: Be careful not to tighten the shuttle race set screw (No.6) excessively because a load is applied to the rotating shaft and it causes trouble.

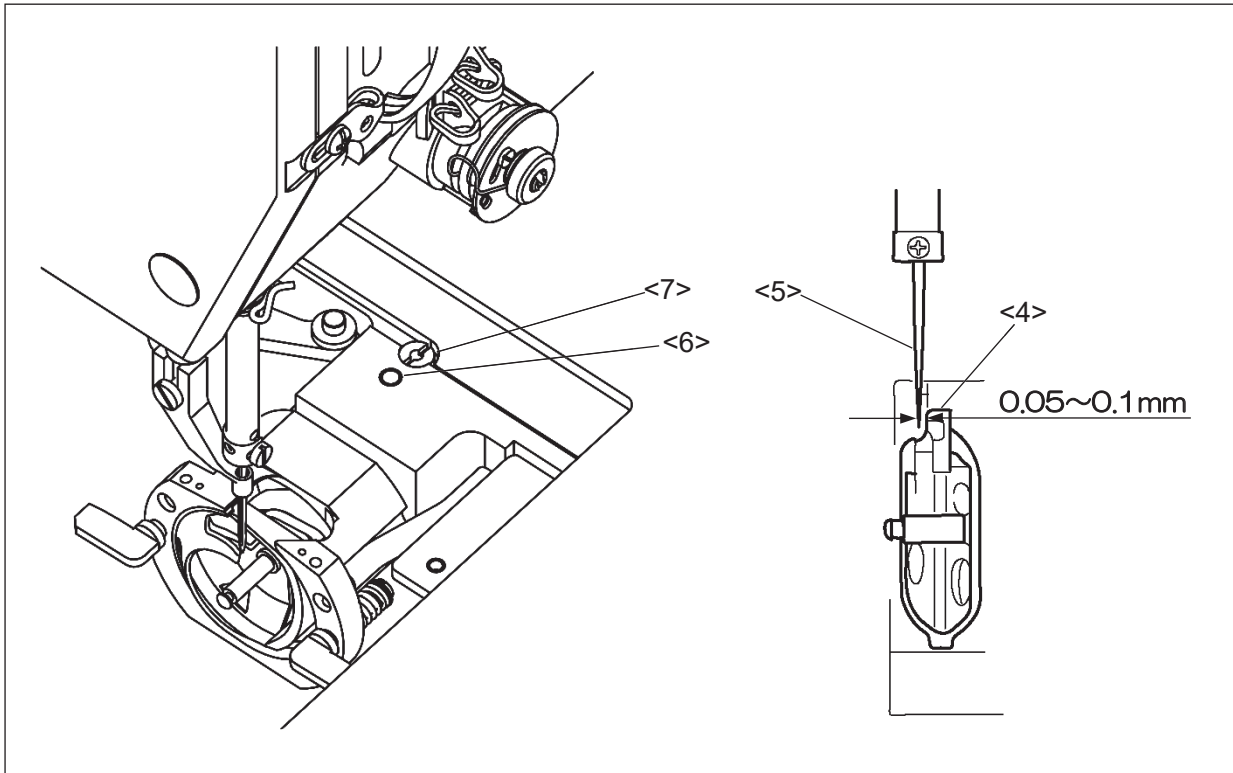

<4>: Shuttle hook point <5>: Needle <6>: Shuttle race set screw <7>: Eccentric pin

6-2-4. Adjustment of the clearance between the driver and the needle

- (1) Remove the two screws (No.1) and remove the screw cover (No.2).
- (2) Check the clearance between the shuttle hook point and the needle has been adjusted in 0.05 to 0.1mm.
- (3) Loosen the lower shaft bushing screw (No.3) and turn the eccentric pin (No.4) so that the driver (No.6) moves back and forth. Adjust the clearance between the needle (No.5) and the driver (No.6) in 0 to 0.05mm, and tighten set screw (No.3). (*1) After adjusting, check that the pulley can be turned lightly by hand.

*1: Be careful not to tighten the lower shaft bushing screw (No.3) excessively because a load is applied to the rotating shaft and it causes trouble.

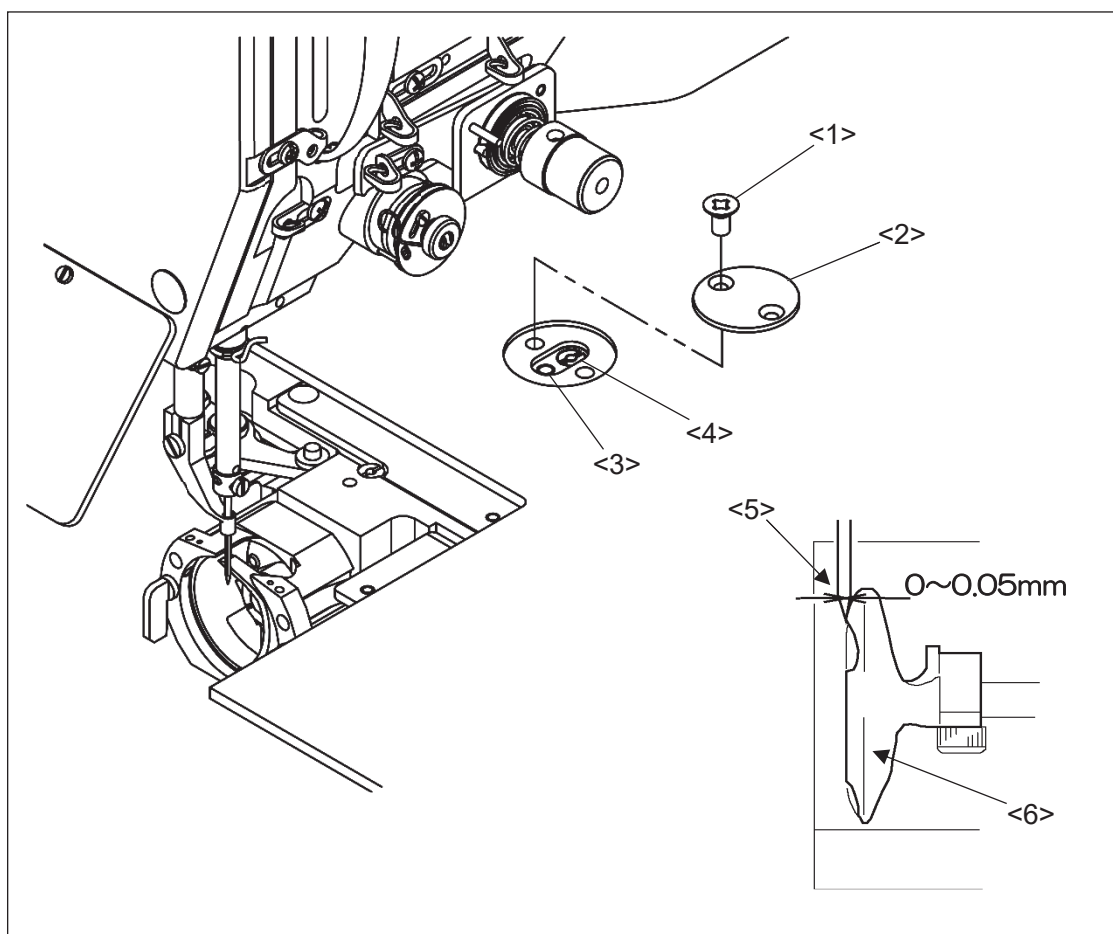

<1>: Screw <2>: Screw cover <3>: Lower shaft bushing screw <4>: Eccentric pin
<5>: Needle <6>: Driver

6-2-5. Adjustment of the shuttle race thread guide

According to following procedures, assemble the removed shuttle race thread guide.

- (1) Match the hole in the shuttle race thread guide (No.1) with the needle bar center line (No.3) so that the shoulder (No.4) of the shuttle race thread guide matches with the rear side line of the needle (No.6). At this time, make sure that there is a clearance between the hook retainer (No.7) and the hole of shuttle race thread guide (No.2) at least the thread can be passed through. (The standard clearance is 0.8mm.) The wide clearance causes the trimming failure. After adjustment tighten the screws (No.5).

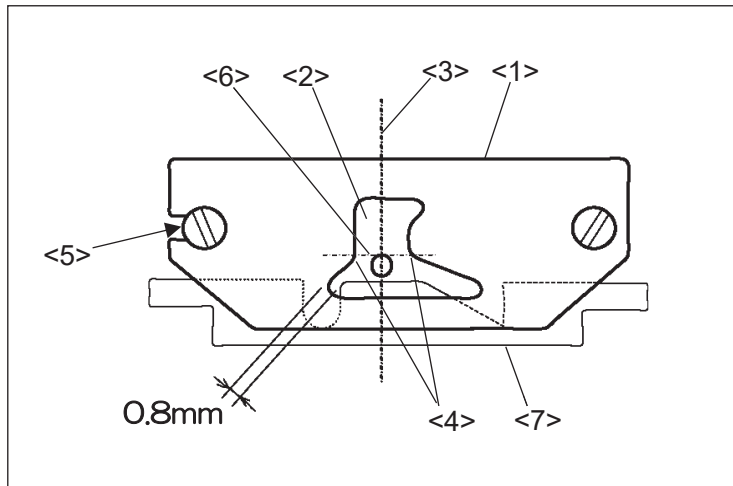

- <1>: Shuttle race thread guide
- <2>: Hole of shuttle race thread guide
- <3>: Needle bar center line
- <4>: Shoulder
- <5>: Screw
- <6>: Rear side line of the needle
- <7>: Hook retainer

6-2-6. Adjustment of the timing between the hook and the needle motion

The timing between hook and needle motion can be adjusted by operation panel. Please refer to the **OPERATION PANEL** technical manual if needed.

(1) Remove the all of any parts, tools and screws on the sliding table. After make sure the work environment safety, Turn the power switch on. At this time, do not press the home position return icon .

NOTE From the first home position returning after turn on the power switch, the hook and needle timing information is stored. This timing information cannot be overwritten when the power switch turned on. In this reason, please operate this adjustment before press the home position return icon.

(2) Press the  icon from the function mode.

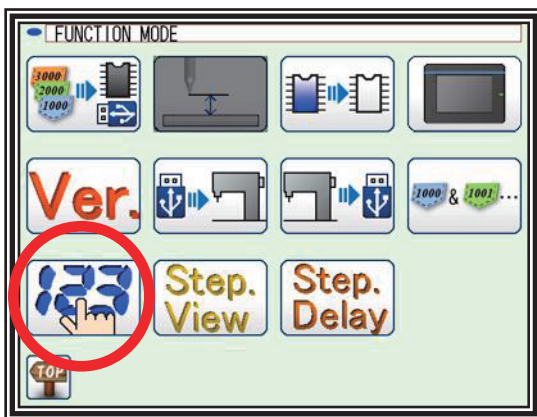

(3) Input the pass word, and press the  icon.

NOTE If press the home position return icon, the  icon is displayed with shading  and

(4) Press the main motor up position setting icon.

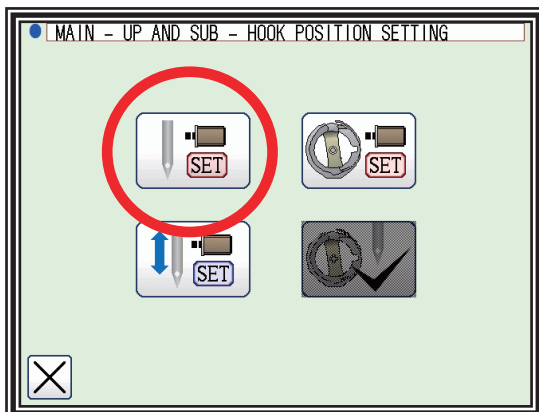

(5) Following the screen indication, set up the main motor up position.

After the completion of setting, press the  icon and then press the  icon.

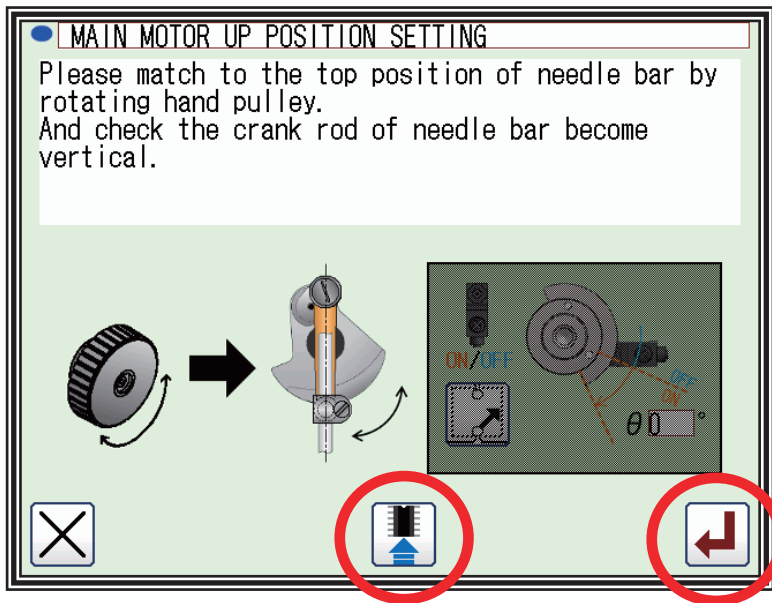

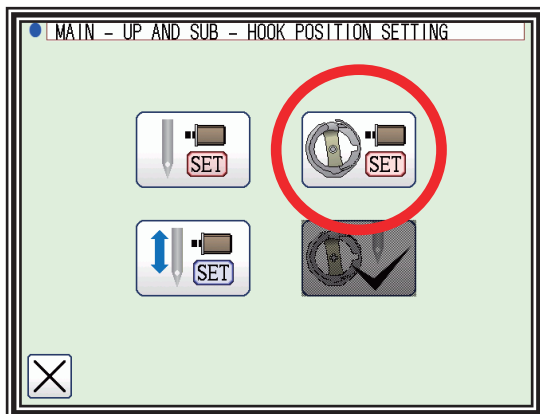

(6) Press the sub motor hook position setting icon.

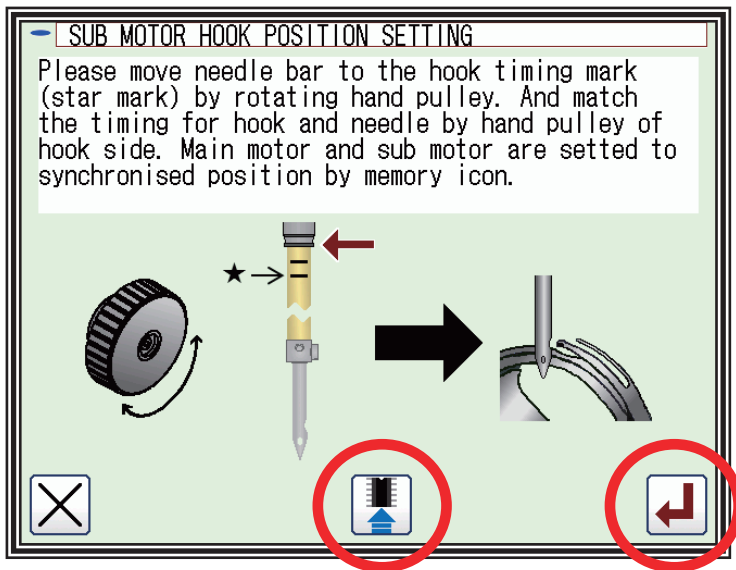

(7) Following the screen indication, set up the sub motor hook position.

After the completion of setting, press the  icon and then press the  icon.



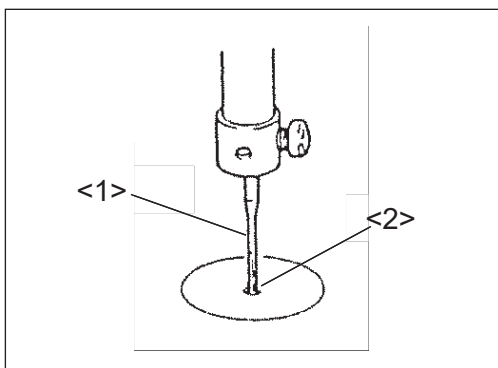

- (8) Press the home position return icon . After completing the origin return operation, press the  on the standard screen. Turn the hand pulley by hand and make sure the timing between hook and needle motion is performed sufficiently as described above.
- (9) After adjustment turn the power switch off.
- (10) After adjustment, put the sliding plate and bobbin case to the original locations and close the bobbin access door.
- (11) When put the sliding plate back on the sewing machine, in order for the needle (No.1) to come into the right center of the needle hole of the needle plate (No.2), make sure that the needle plate hole center matches with the needle point then, tighten the set screws.



<1>: Needle
<2>: Center of the needle hole

6-3. Adjustment of the oil lubrication

(1) Amount of oil supply is controlled by specified injection time for every specified stitch number. The lubrication oil is injected by compressed air.

Press the  on the standard screen, and press the  icon.

Select the  icon and enter the setting mode.

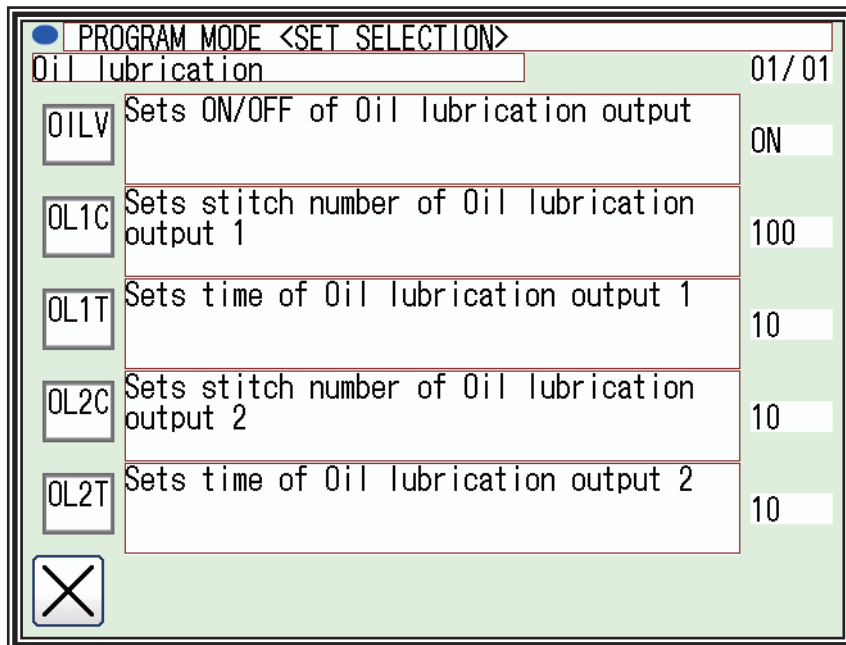

O11C: Setting of the machine head oil injection timing for every stitch number.

O11T: Setting of the machine head oil injection time.

O12C: Setting of the shuttle hook oil injection timing for every stitch number.

O12T: Setting of the shuttle hook oil injection time.

Default oil injection setting is described below.



Machine head: one second for every ten thousand stitches.



Shuttle hook: one second for every one thousand stitches.

NOTE1 Please adjust the oiling amount for each sewing condition. For example, increase the (O11C, O12C) value or shorten the oil injection time (O11T, O12T) when much oil is consumed. However it is necessary to note the machine seizing when limit the oiling amount.

NOTE2 When shorten the oil injection time (O11T, O12T), set the value to 3-5 as a guide.

(2) It is also possible to lubricate once at the sewing start, instead of setting the oil injection timing for every stitch number (O11C, O12C). Please change the set value as following.

Press the  on the standard screen, and press the  icon.

Select the  >  > ST [Valid the oil lubrication output at start of sewing] in order. However, oil consume may increase when use this function. In this case, shorten the oil injection time (O11T, O12T).

6-4. Setting of the presser foot movement

It is not necessary to adjust the presser foot movement with operating the mechanical unit. Please refer to the instructions **OPERATION PANEL** technical manual and change each setting in matching with the sewing conditions.

(1) Adjustment of the presser foot height position:

Please refer to [9] Controlling the Presser Foot.

(2) Adjustment of the presser foot timing and stroke:

Please refer to [18] [Easy setting] 1-(3) [PF motion setting].

(3) Adjustment of the presser foot lift:

Please refer to [18] [Easy setting] 3-(2) [PF rising position adjustment].

6-5. Adjustment of the wiper

(1) Shut off the air supply and loosen the wiper set screw (No.3) and adjust the wiper (No.1) to be positioned where the wiper (No.1) passes under the needle (No.2) point with a clearance of about 2mm right after the sewing machine stops at the take up lever upper position.

(2) When setting the presser foot (No.4) to upper position during the sewing of thick material, the setting may not leave the clearance of passing wiper. The wiper cannot be used in this case.

(3) The wiper does not work enough, loosen the wiper adjust screw (No.5) and adjust the wiper position.

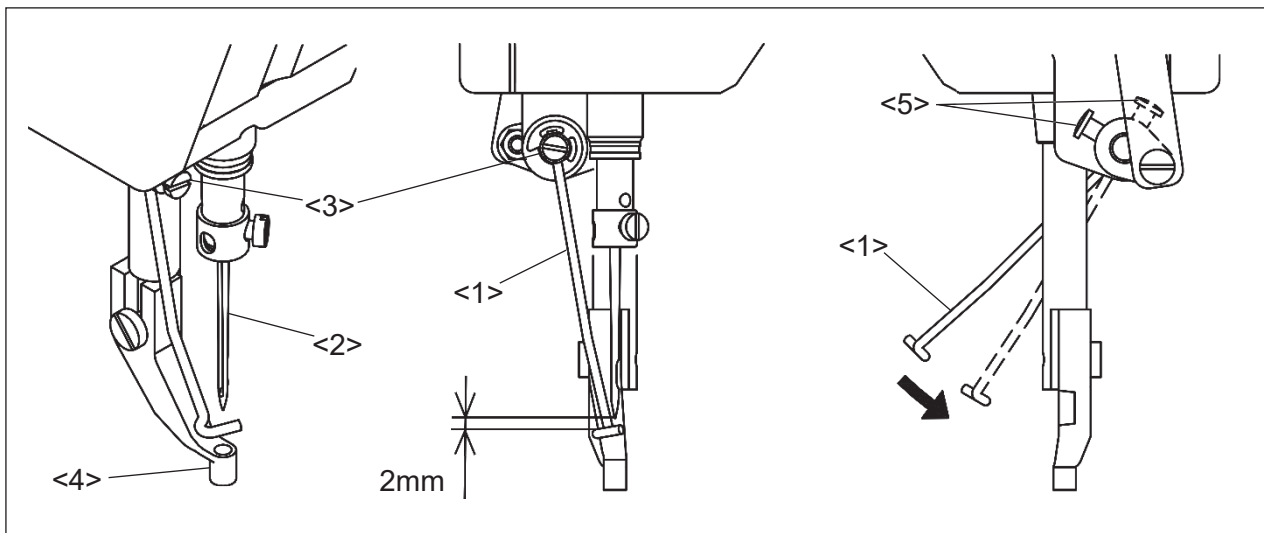



<1>: Wiper <2>: Needle <3>: Wiper set screw <4>: Presser foot <5>: Wiper adjust screw

(4) When the wiper function is not be used (not able to be used), set the following.

Set the wiper function to off.

Press the  on the standard screen to open the MENU mode.

(5) Press the  >  >  [Wiper ON/OFF] in order.

(6) Select the  on the [Wiper ON/OFF] screen, and press the .

6-6. Adjustment of the thread take up spring

6-6-1. Adjusting movable range of the thread take up spring

(1) To adjust the thread take up spring (No.1), loosen the stopper stop screw (No.2) and move the stopper (No.3). When moved the stopper (No.3) in the arrow direction, movable range of the thread take up spring (No.1) is increased.

(2) After adjustment tighten the stopper stop screw (No.2).

NOTE Standard stopper (No.3) position is showing in following figure. The take up spring (No.1) position is set to be the almost same height of the center line <A> of the thread take up spring unit (No.4).

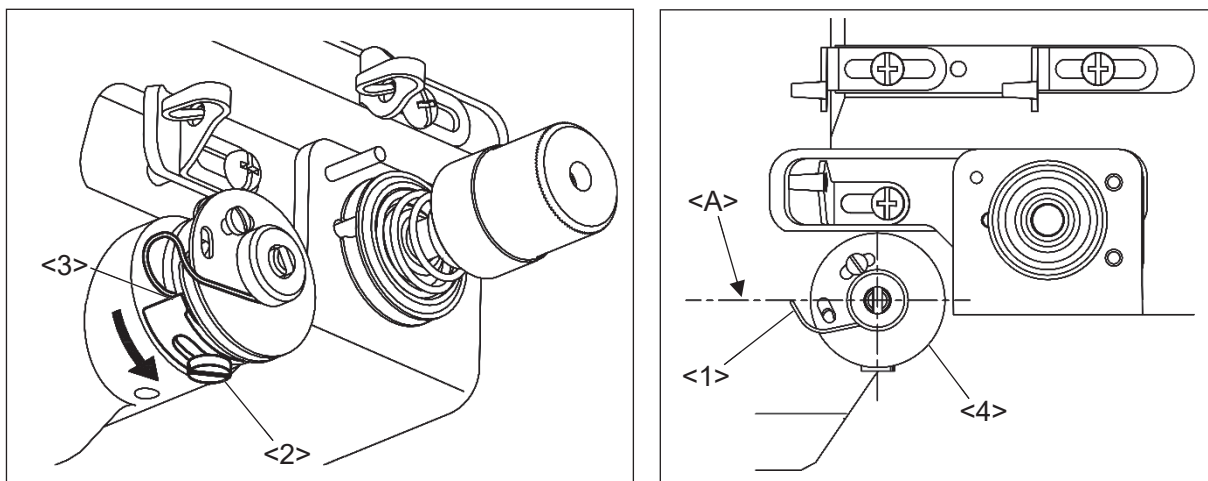

<1>: Thread take up spring <2>: Stopper stop screw <3>: Stopper <4>: Thread take up spring unit

6-6-2. Adjusting intensity of the thread take up spring

(1) Loosen the lock nut (No.1) and turn the adjusting shaft (No.2) with screw driver. When the adjusting shaft (No.2) won't screw well, loosen the set screw (No.3) slightly. When tightening the screw driver clockwise, the thread take up spring tension becomes loose, and when loosening the screw driver counterclockwise, the thread take up spring tension becomes tight.

(2) After adjustment, tighten the lock nut (No.1).

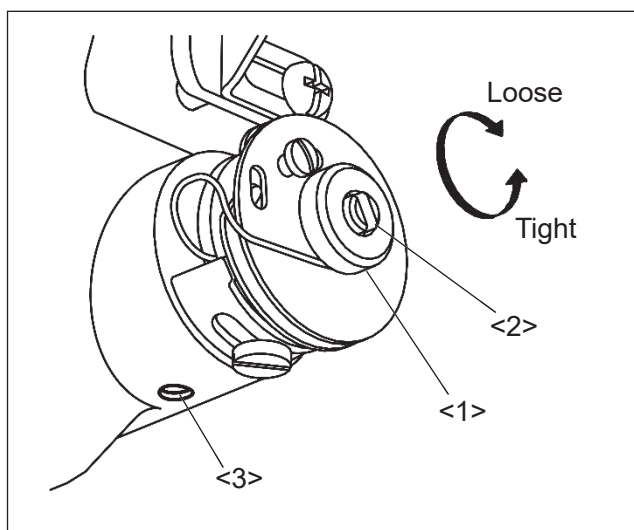

<1>: Lock nut
<2>: Adjusting shaft
<3>: Set screw

6-7. Adjustment of the thread tail after the trimming

- (1) Adjust the thread tail with the pre-tension (No.1).
- (2) When turning the nut (No.2) clockwise, the thread tail becomes shorter. When turning the nut (No.2) counterclockwise, the thread tail becomes longer.

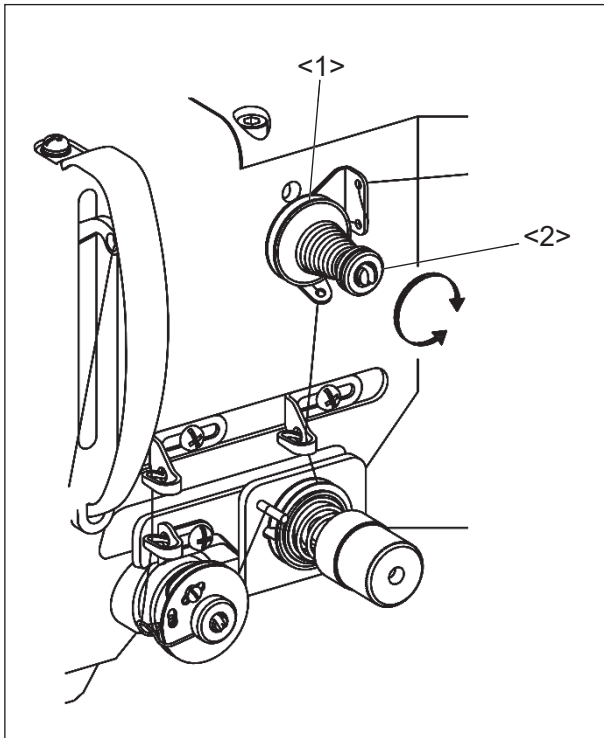

<1>: Pre-tension

<2>: Nut

6-8. Adjustment of the air pressure



★ If the secondary side air pressure is set too high, trouble such as operation faults may occur. Always set the pressure to within 0.4Mpa.

- (1) Air pressure is provided from an air source. Lift and turn the air regulator's adjustment knob (No.1) located under the table to adjust the air pressure.
- (2) If turn the adjusting knob (No.1) to the clockwise, the air pressure is increased.
- (3) If turn the adjusting knob (No.1) to counter clockwise, the air pressure is decreased.
- (4) 0.4Mpa (4kgf/cm²) is the standard air pressure as a normal sewing operation.

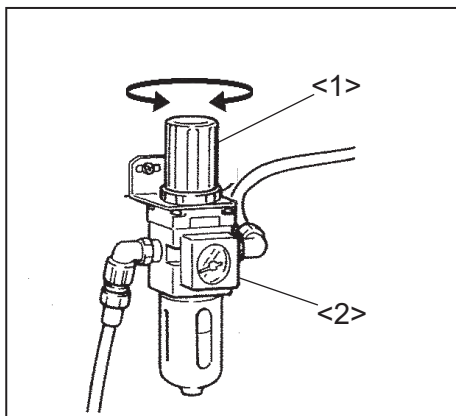

<1>: Adjusting knob

<2>: Air regulator

7. VARIOS ADJUSTMENT



CAUTION

- (1) Please make sure to turn the power switch off before adjusting the sewing machine.
- (2) When adjusting the sewing machine with the power switch on, please be careful not to step on the foot switch by mistake.
- (3) Please be careful not to be injured by a sharp part such as the needle and the hook point.
- (4) Please make sure to put the safety guards (eye guards, link covers, and finger guards or the others) back on the initial position after the sewing machine adjustment.

7-1. How to exchanging the tension spring of the needle thread tensioner unit

According to following procedures, exchange the tension spring (No.1). It is same way to exchanging the optional stronger tension spring.

NOTICE It is required to use the factory original tension spring.

- (1) Turn the thumb screw (No.2) and decrease the tension spring pressure.
- (2) Loosen the set screw (No.4) and then remove the set screw (No.3) and remove the thumb screw (No.2).

The set screw (No.3) and (No.4) are same parts.

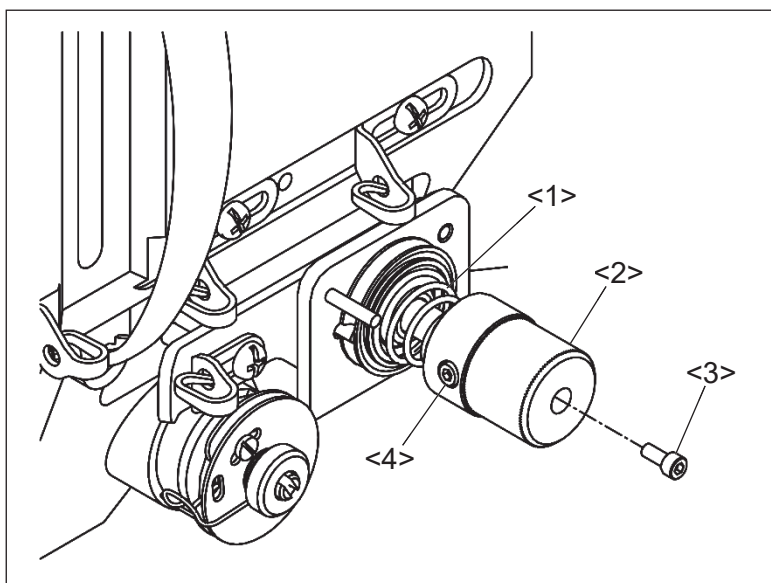

<1>: Tension spring

<2>: Thumb screw

<3>: Set screw

<4>: Set screw

(3) Pull out the thumb screw (No.2) from tensioner shaft (No.5). In this time the bearing (No.6) is removed too.

(4) Remove the tension spring (No.1).

(5) After exchanging the tension spring (No.1) back the bearing (No.6) and thumb screw (No.2) in order.

Then tighten the set screw (No.4) and screw (No.3) in order.

NOTE 1 Bearing (No.6) is consist of three parts. Please taking care not to make misassembling by referring following figure.

NOTE 2 Locate the groove of the tension disc (No.9) to the thread release pin (No.12) when removed tension disc (No.9), (No.10) and tension disc holder (No.11).

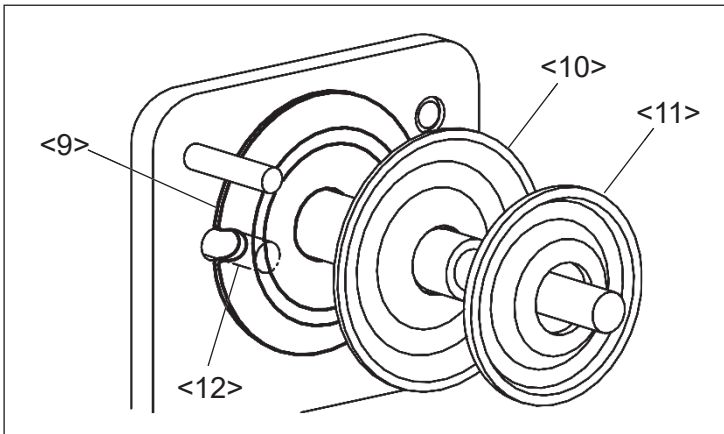
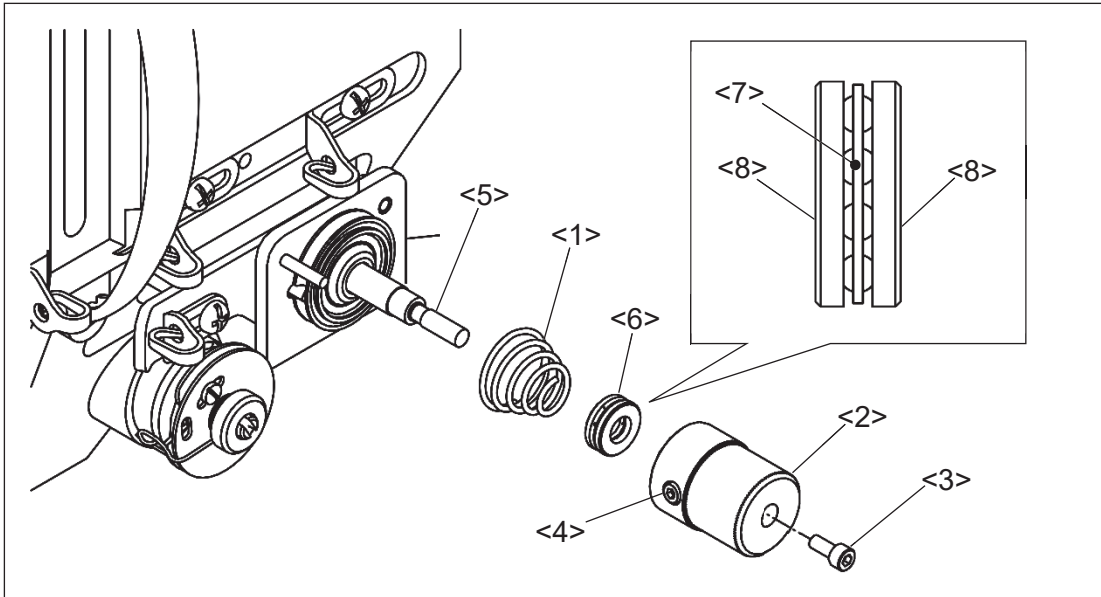

- <1>: Tension spring <2>: Thumb screw <3>: Set screw <4>: Set screw
<5>: Tensioner shaft <6>: Bearing <7>: Bearing holder <8>: Washer
<9>: Tension disc <10>: Tension disc <11>: Tension disc holder
<12>: Thread release pin

7-2. Adjustment of the detector position of the presser foot unit

According to following procedures, adjust the detector position in case of parts replacement etc.

NOTE The presser foot lifting position is setting by 18 mm from top of the sliding plate.

NOTICE The presser foot movement is based on the origin detection position. To prevent the sewing trouble and parts breaking, adjust the detector position exactly.

(1) Remove the eye guard (No.1) by referencing the previous paragraph [3-4. Installation of the eye guard]

(2) Remove the three of fixing screws (No.2) and remove the face cover (No.3). In this time not to pull the cable of the abnormal stitch detector (No.5).

(3) Remove the needle (No.4).

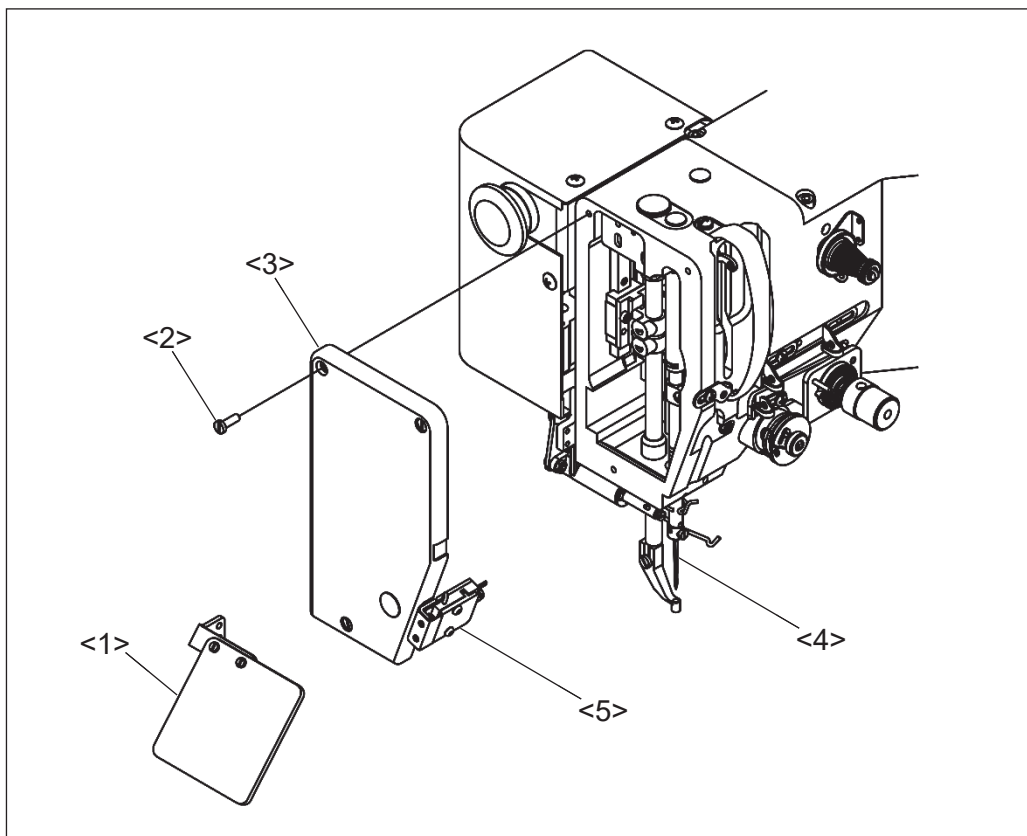

<1>: Eye guard <2>: Fixing screw <3>: Face cover <4>: Needle
<5>: Abnormal stitch detector



(4) Detector (No.4) is installed in machine head. Detector (No.4) detects end of the presser bar (No.5).

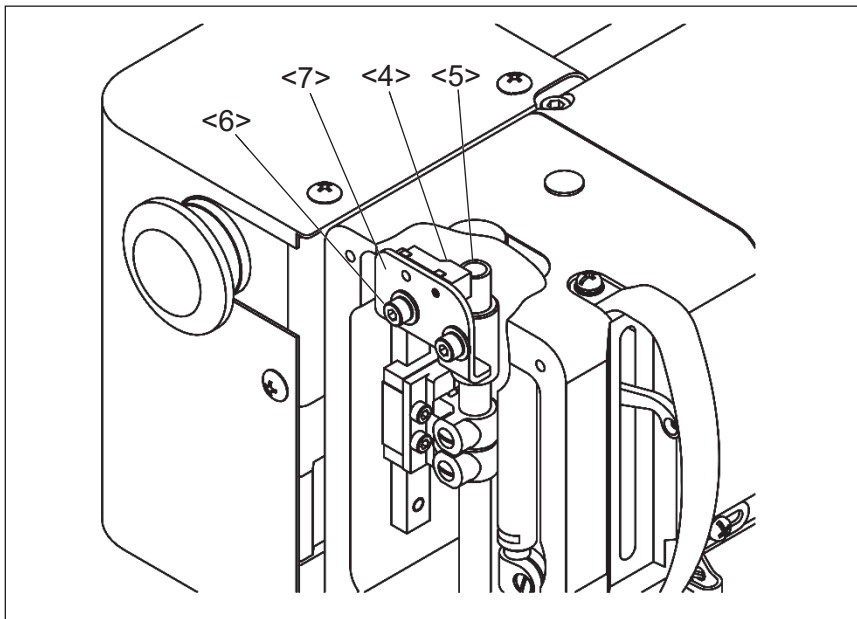

Before adjustment, it is necessary to make sure following items.

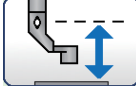

- <4>: Detector
- <5>: End of presser bar
- <6>: Fixing screw
- <7>: Detector bracket

(a) Press the  from standard screen and check if the presser foot height value (ZTHK) is [***].
(No setting) If different, please change to the initial set value.

(b) Press the  >  >  >  from standard screen and check if the presser foot lifting value is [18.0 mm]. If different, please change to the initial set value [18.0 mm].

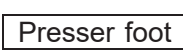
(c) Press the  >  >  > ZNPP [Distance from PF sensor edge to the top surface of slide plate]. Check if the value is [240] (24.0 mm). If different, please change to the initial set value [240].

(d) For prevent the detection error, please use the factory default presser foot.

(e) For prevent the detection error and miss positioning of presser foot height, please check if the presser foot installed fully to the presser bar's mounting face.

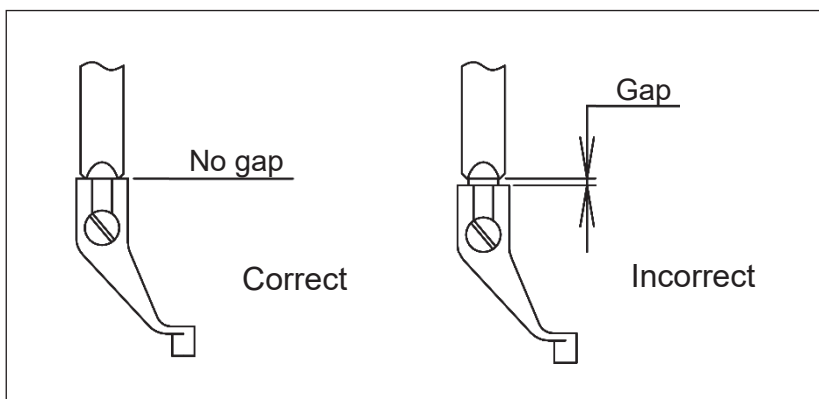

- (5) Loosen the fixing screw (No.6) and move the detector bracket (No.7) upward in advance then tighten the fixing screw (No.6) temporarily.
- (6) Remove the sewing material and work holder and any parts. After make sure the work environment safety, Turn the power switch on.
- (7) After finish the origin movement, make sure the clearance between the bottom of presser foot and top of the sliding plate is 18 mm. If this clearance is more, loosen the fixing screw (No.6) and move downward the detector bracket (No.7) and tighten the screw again and press the origin return icon.

NOTICE Please be careful not to step on the foot switch by mistake.

- (8) Continue the above adjustment up to be a correct distance 18 mm.

NOTICE From the second home position returning, it does not use the home position return sensor. Make sure to turn the power switch off to change the mechanical home position.

To use the sensor from the second returning, press **Program** > >

[Home returning method since the second time returning] on the standard screen and set it ON.

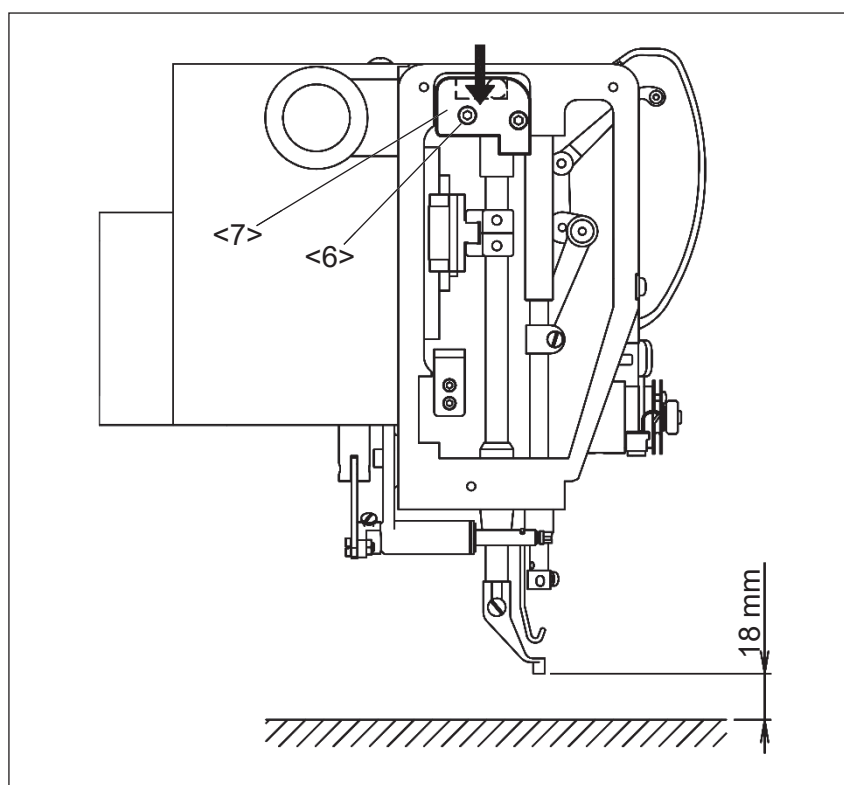

<6>: Fixing screw
<7>: Detector bracket

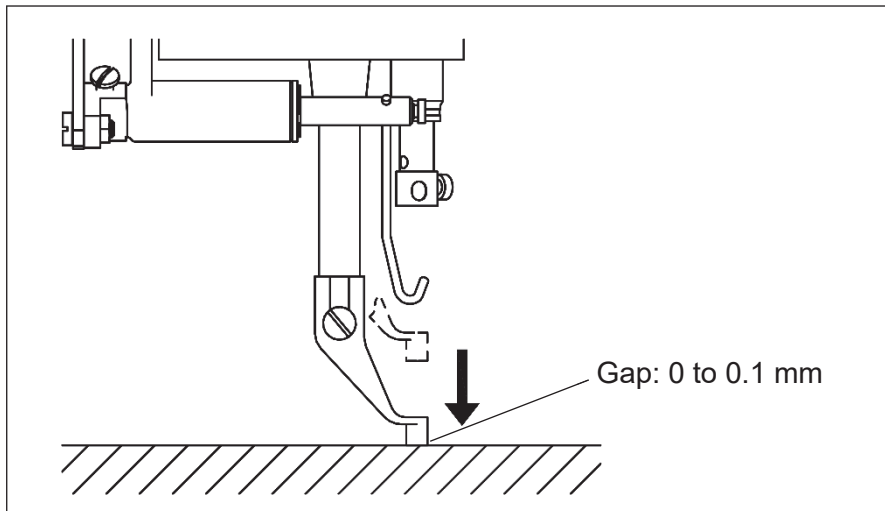

(9) Press the presser foot down icon and check the gap between bottom of presser foot and top of sliding plate is 0 to 0.1 mm. If there is any collision sounds when down the presser foot, please readjust above. If the gap more than 0.1 mm, please readjust too.

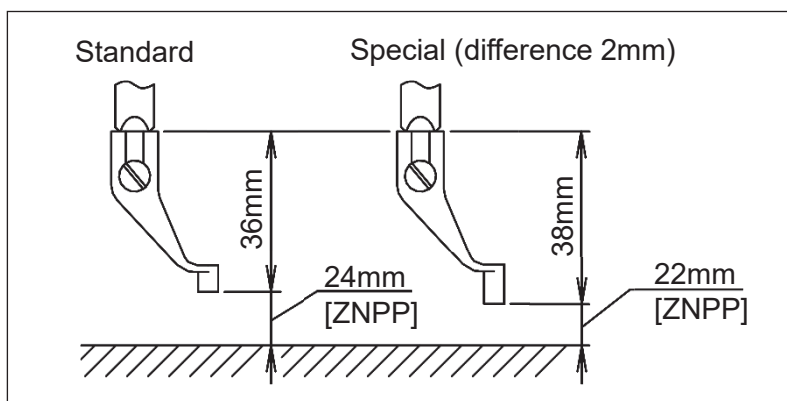

7-3. How to replace with a special presser foot

When replace the standard presser foot only at needed, it is necessary to change the ZNPP [Distance from PF sensor edge to the top surface of needle plate] from default value. For example, to using a special presser foot which length is 2 mm longer, change the value to [220] (22.0 mm) from default value [240] (24.0 mm) as showing in the following figure. According to the following procedures change the ZNPP value.



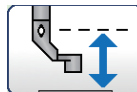

(1) Press the  >  >  >  [PF position adjustment] from standard screen.

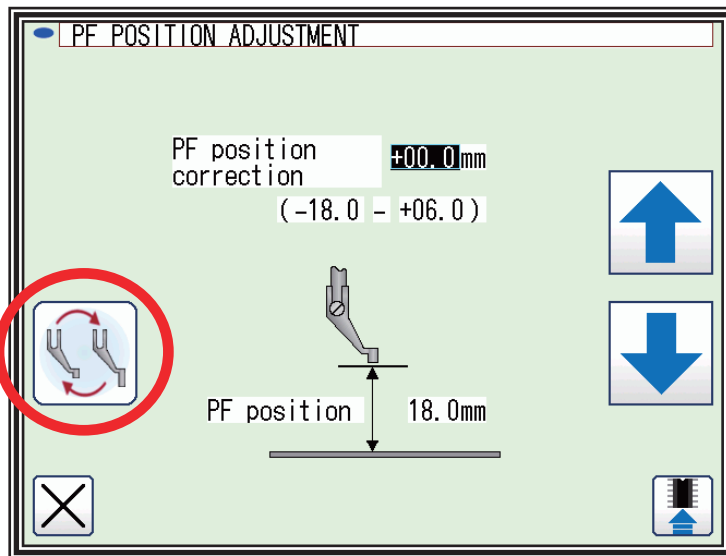
(2) Press the  icon from the [PF position adjustment] screen.





(3) Replace the presser foot with standard one.

(4) Press the   icon and down the presser foot to the top of the needle plate. In this time, set the gap between bottom of presser foot and top of needle plate to be 0 to 0.1 mm. The screen indicates ZNPP default value (Upper) and current value (Lower).

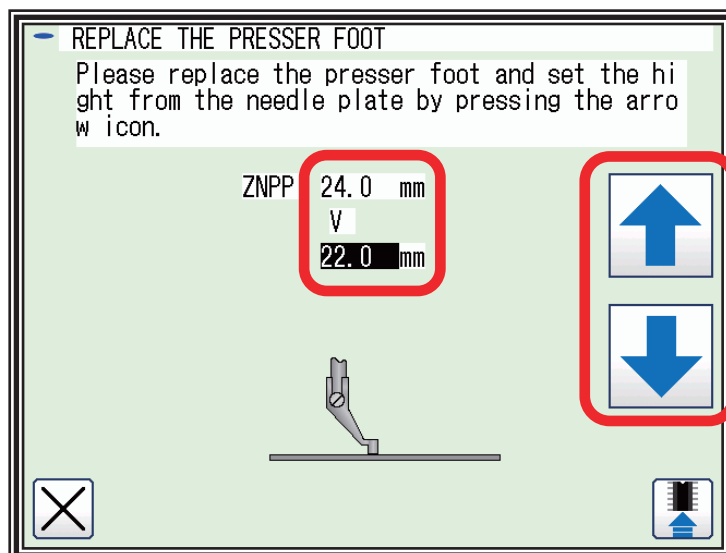
NOTE The ZNPP value can be set every 0.1 mm.



(5) After the completion of setting, press the memory icon  and then press the  icon.

NOTE The ZNPP value is flickering until press the  icon.

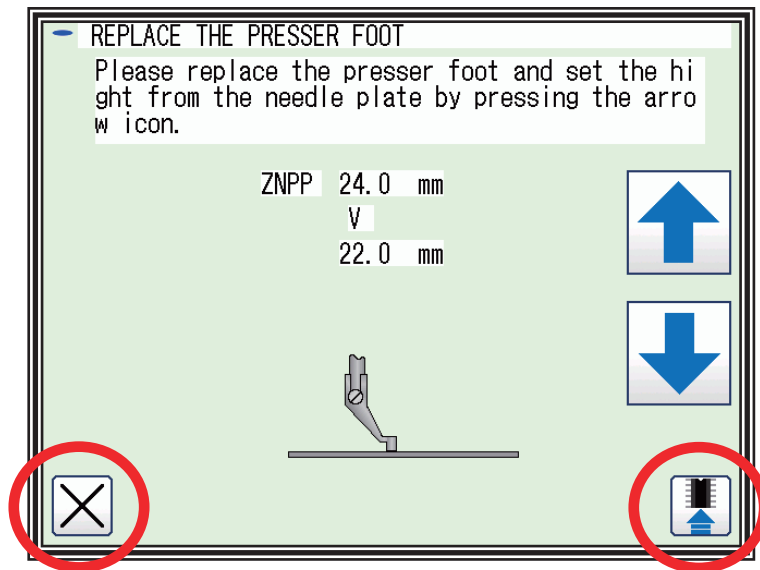

(6) Following the screen indication, put the power switch off.

7-4. Adjustment of the presser foot holder position

- (1) Turn off the machine power and down the presser foot (No.7) by hand to the top of the sliding plate.
- (2) Loosen the each of set screws (No.5) which has presser foot holder (upper) (No.3) and presser foot holder (lower) (No.4).
- (3) Adjust the clearance between the rack gear (No.1) to stopper (No.2) becomes 5 mm by moving the presser foot holder (upper) (No.3) and presser foot holder (lower) (No.4) position.
- (4) After adjustment make sure if the presser foot (No.7) is remaining on the sliding plate. On the other hand, adjust the presser foot hole position to the needle (No.8) with turning the presser bar.
- (5) Then tighten the each of set screws (No.5) securely while holding the block (No.9) by both presser foot holders (No.3), (No.4) and make sure if there are no gap between both presser foot holders (No.3), (No.4) and block (No.9).

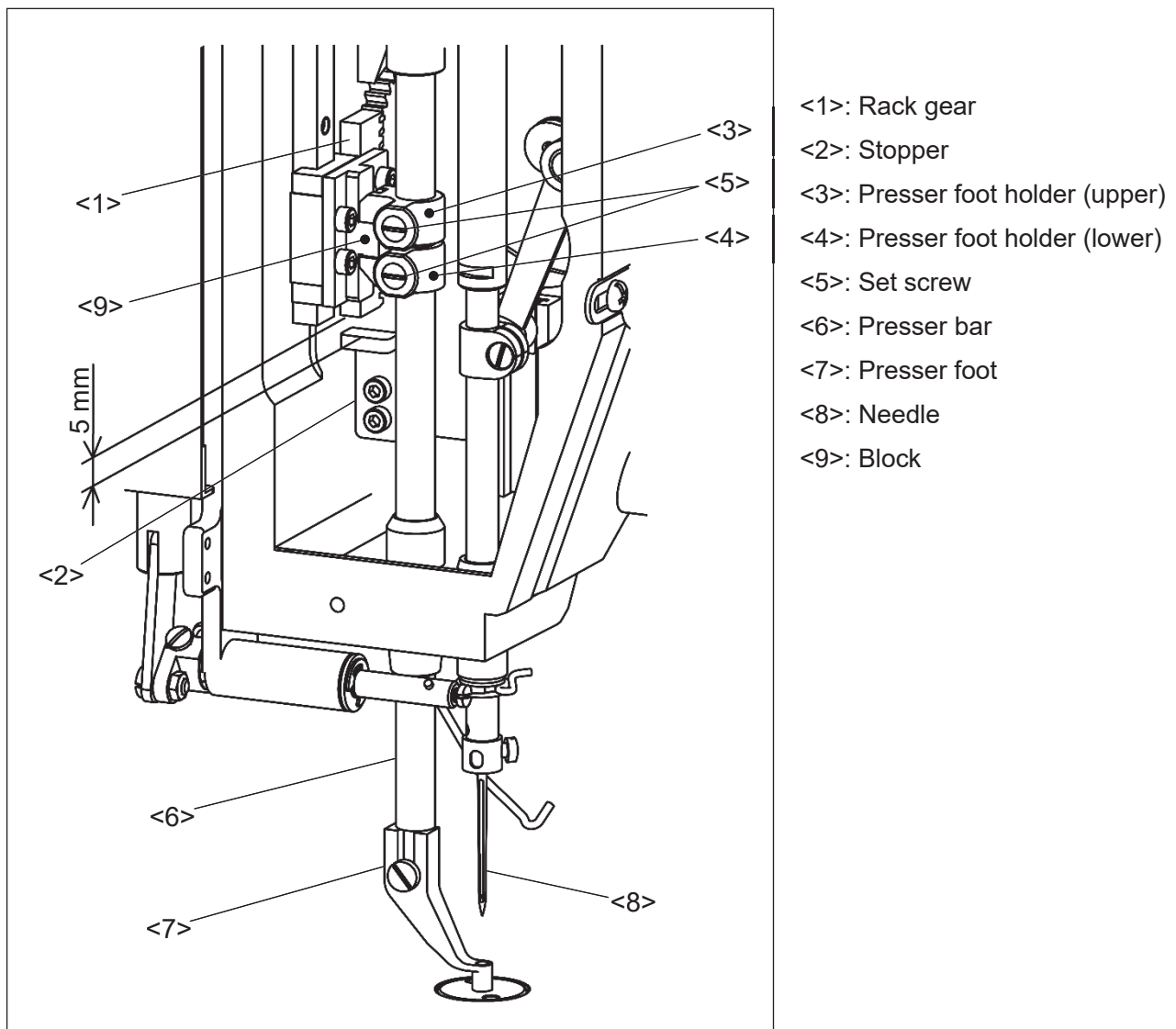

7-5. Adjustment of the thread trimmer

When remove the component of the thread trimmer mechanism for maintenance, please refer to following adjustment procedures.

7-5-1. Adjustment of the movable knife

(1) Remove the sliding plate (No.1) by referring to the paragraph <6-2-1>.

(2) Aligning the center of the trimmer link hole (No.2) with the reference hole (No.3) as below figure.

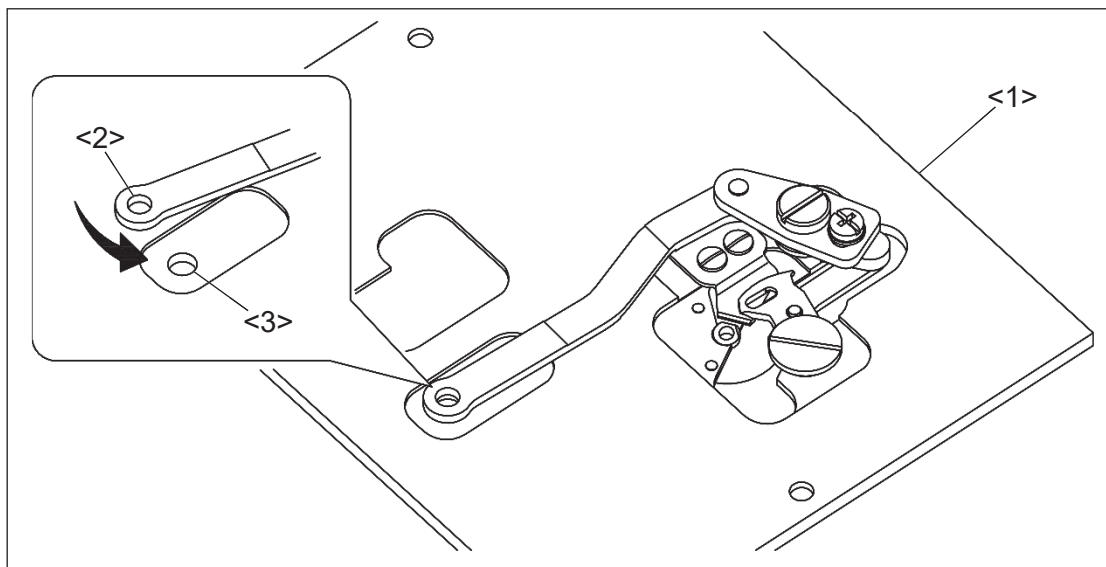

<1>: Sliding plate <2>: Trimmer link hole <3>: Reference hole

(3) Please confirm if the tip of movable knife (No.5) is on a virtual plane of the machining surface of sliding plate (No.4) as below figure. In this time, keep aligning the center of the trimmer link hole (No.2) and the reference hole (No.3).

(4) If different, loosen the screw (No.6) and adjust the tip of movable knife (No.5) position by moving in the arrow direction. In this time, keep aligning the center of the trimmer link hole (No.2) and the reference hole (No.3) too.

(5) After adjustment, tighten the screw (No.6) and reconfirm the tip of movable knife (No.5) position.

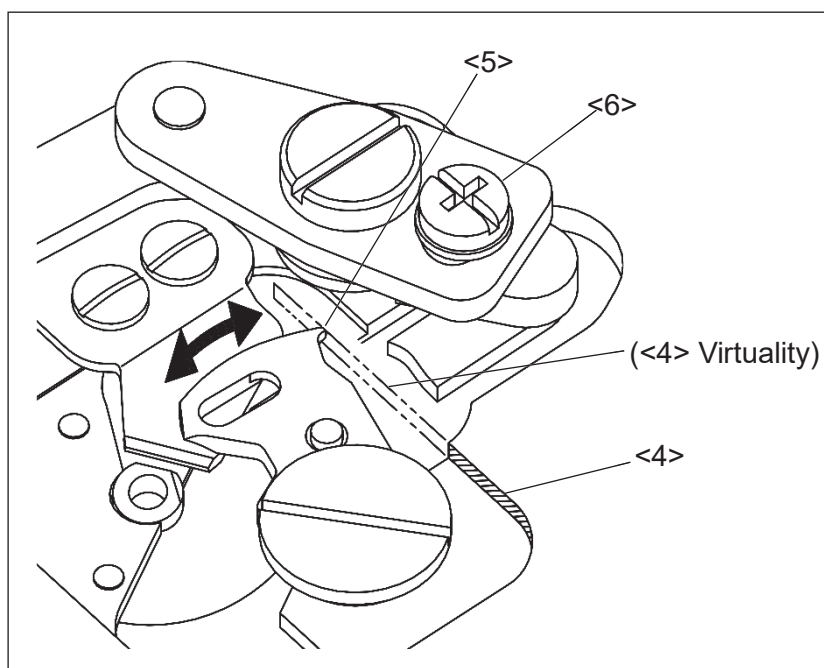

<4>: Machining surface
<5>: Tip of movable knife
<6>: Screw

7-5-2. Adjustment of the fixed knife

(1) Confirm the clearance between blade edge of fixed knife (No.1) and edge of the needle plate (No.2) is 1.5 mm.

(2) If different, loosen the screw (No.3) and adjust the clearance.

NOTE If the clearance is smaller than 1.5 mm, it may cause any trimming failure or unstable trimming length.

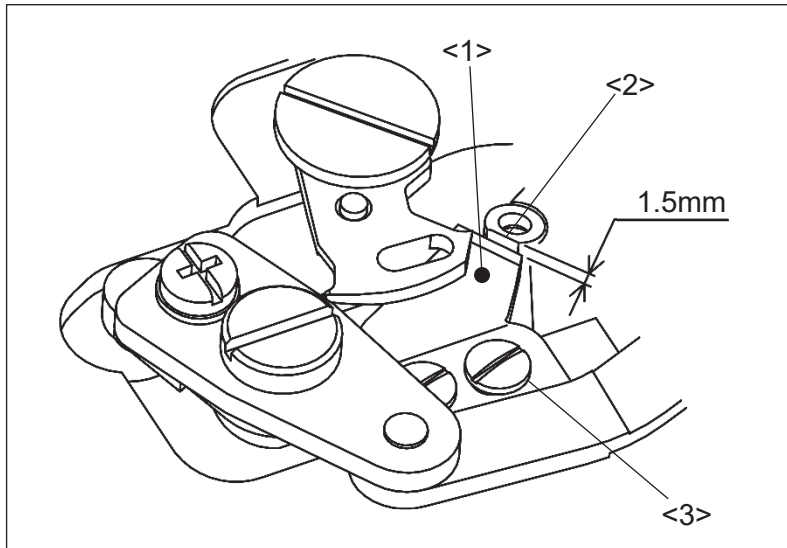

- <1>: Fixed knife
- <2>: Edge of the needle plate
- <3>: Screw

7-5-3. Adjustment of the trimmer cam detector position

The trimmer system has origin detector (No.2) which detects outer periphery of the cam roller (No.5). The trimmer system's home position is the movable knife standby position which described previous paragraph <7-5-1. Adjustment of the movable knife >. According to following procedures, adjust the detector (No.2) position.

- (1) Turn the power switch off.
- (2) Put the machine power on and press the home position icon from standard screen.
- (3) After finish the origin movement, please check the clearance from "A" direction between trimmer cam (No.1) and cam roller (No.5) is 0.5 mm or less.

NOTE It is necessary readjust the detector position when the trimmer cam (No.1) contact with cam roller (No.5). In this case, movable knife position may different.

- (4) Turn the machine power off and loosen the two of the screws (No.3) and change the detector bracket (No.4) position by moving in the either of arrow direction and confirm above condition.

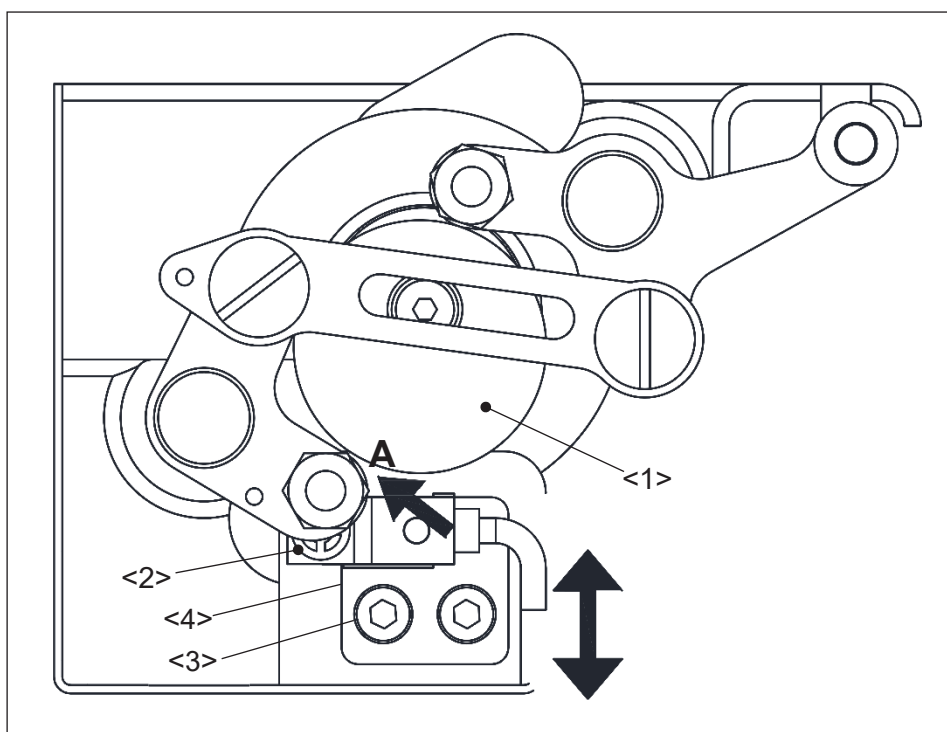

- <1>: Trimmer cam
- <2>: Detector
- <3>: Screw
- <4>: Detector bracket
- <5>: Cam roller

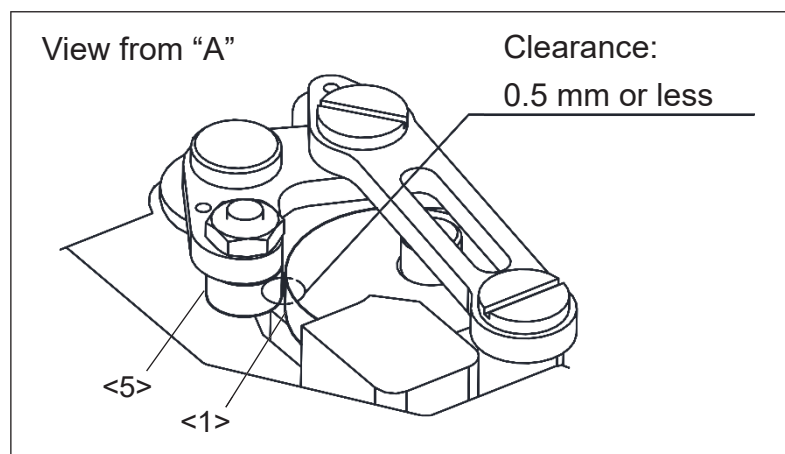

7-6. How to remove the XY cover

When remove the XY cover (No.1) by maintenance, please refer to the following procedures.

NOTICE For the safety, please operate more than one person.

(1) Remove the each one of the screw (No.2) and (No.3) from machine right side.

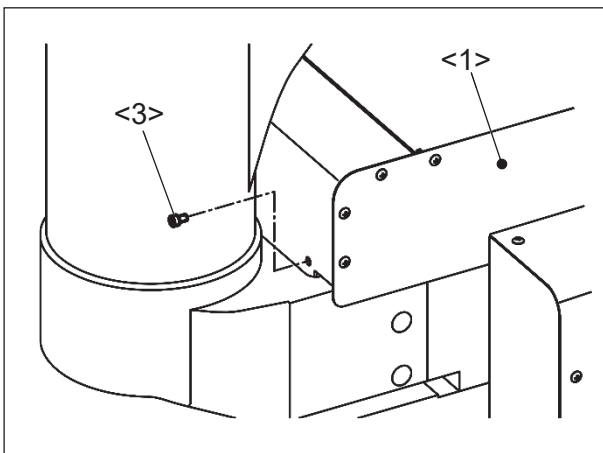
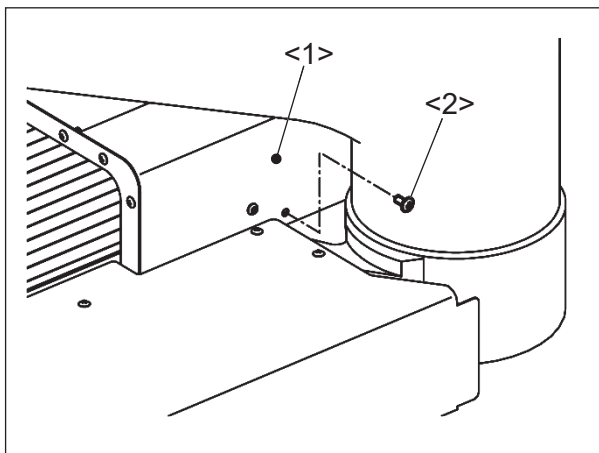

(2) Remove the two of the screws (No.2) from machine left side.

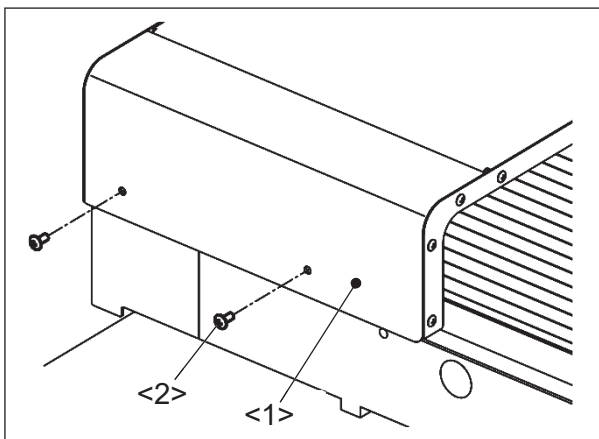

(3) Lift up the XY cover (No.1) up to the bottom of machine arm and move in the arrow direction. XY cover (No.1) can be removed. Please operate more than one person and pay attention to XY table and flexible tube.

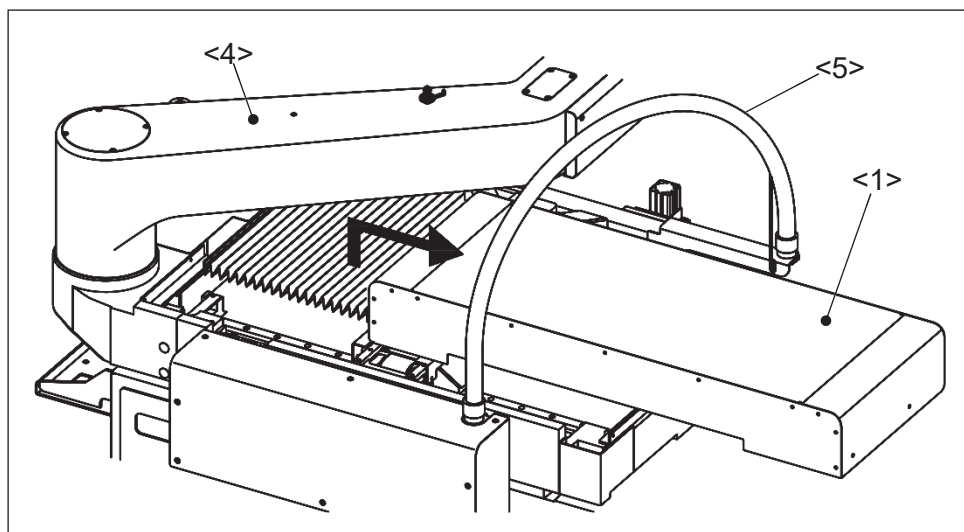

<1>: XY cover <2>: Screw <3>: Screw <4>: Machine arm <5>: Flexible tube

7-7. Adjustment of the XY table detector

XY table detecting position is front left corner of sawing area to the needle center. At the first origin movement when turn the machine power on, XY table moves toward above position. After detection, XY table is back to the center of the sawing area. Before adjusting, it is necessary to remove the XY cover. Please refer to the previous paragraph [7-6.].

[NOTE] When modify the home position somewhere other than the center of sewing area, please refer to the instructions **[OPERATION PANEL]** technical manual [18] [Easy setting 3-(5)].

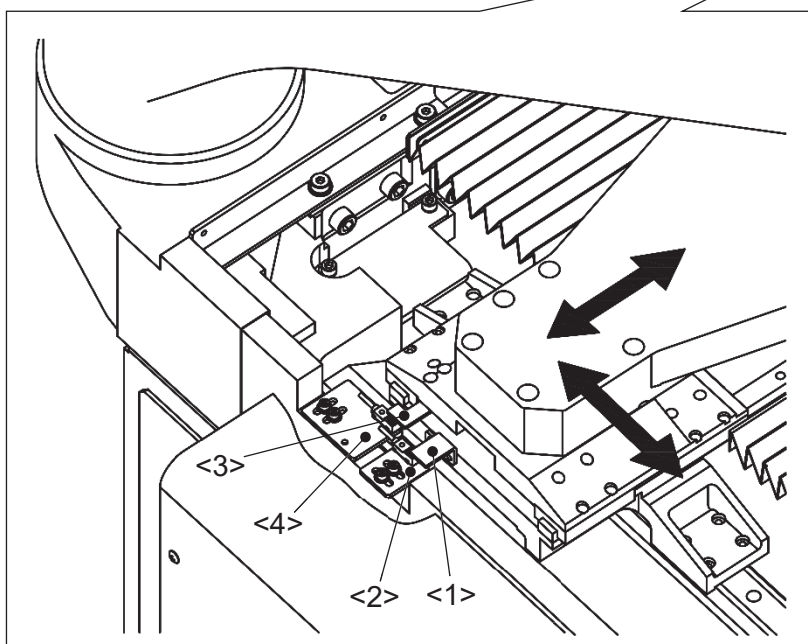
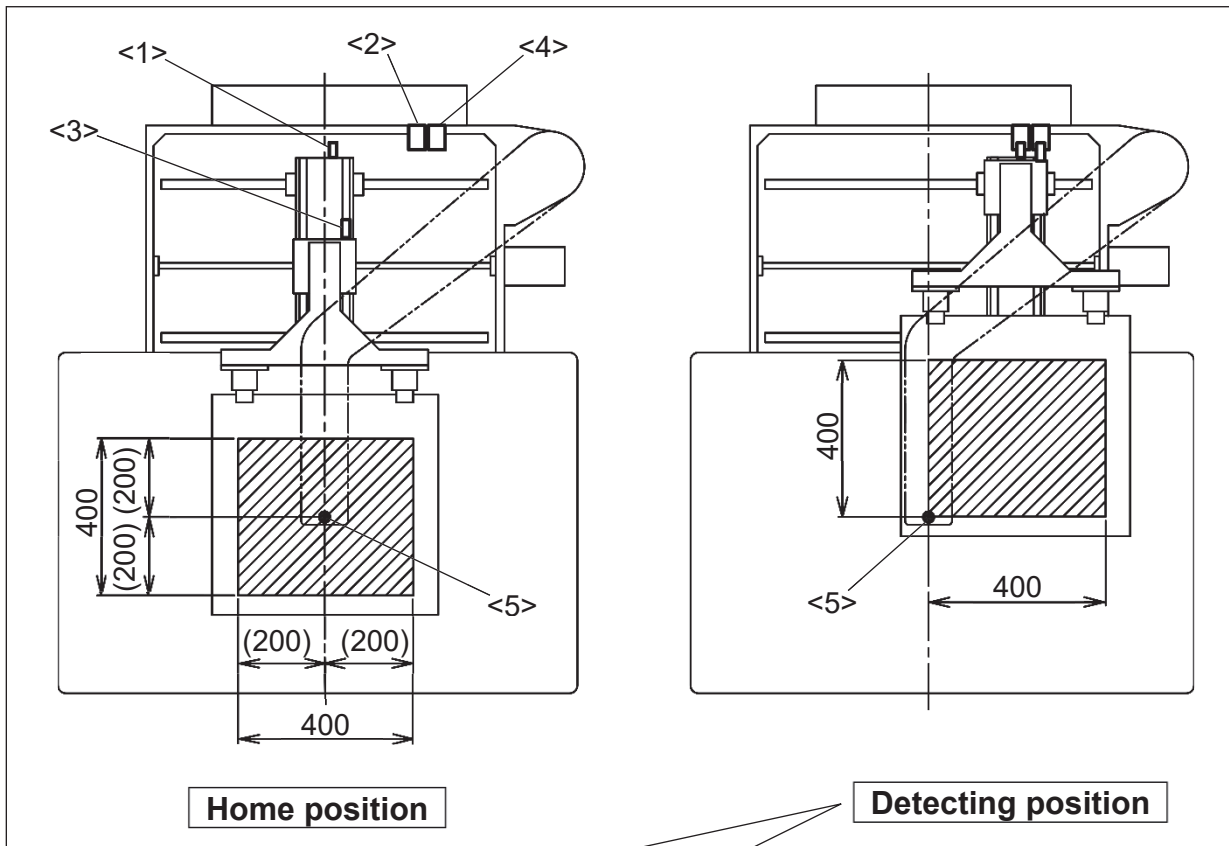

- <1>: X detect plate
- <2>: X detector
- <3>: Y detect plate
- <4>: Y detector
- <5>: Needle

NOTICE The machine has a function that the motor memorizes the home position at the first home position returning operation after the switch is turned on. Therefore, from the second home position returning, it does not use the home position return sensor. Make sure to turn the power switch off to change the mechanical home position.

To use the sensor from the second returning, press **Program** > **home position** > **SHP** [Home returning method since the second time returning] on the standard screen and set it ON.

7-7-1. Adjustment of X direction

- (1) Turn the power switch on and press the home position return icon .
- (2) Turn the power switch off when finish the origin return movement.
- (3) Confirm the distance between X stopper (No.6) and Movable frame (No.7) which showing in hatched area is 210 mm. If different, loosen the two screws (No.8) of the X detector (No.2) and adjust the detectors position. When above distance is more than 210 mm, move the X detector (No.2) in arrow “b” direction. When less than 210 mm, move the X detector (No.2) in arrow “a” direction.
- (4) After adjustment, tighten the screw (No.8) and check again above (1) to (3) procedures.
- (5) Confirm the clearance between detector and detect plate is in the range of 1 to 1.5 mm. If it has any damage with detector or the detect plate, this clearance may different.

NOTICE For the safety, turn the power switch off every time.

NOTE XY table mechanical home position is the center of the sawing area to the needle center. If modified the home position by control panel, please return the setting to default value in advance.

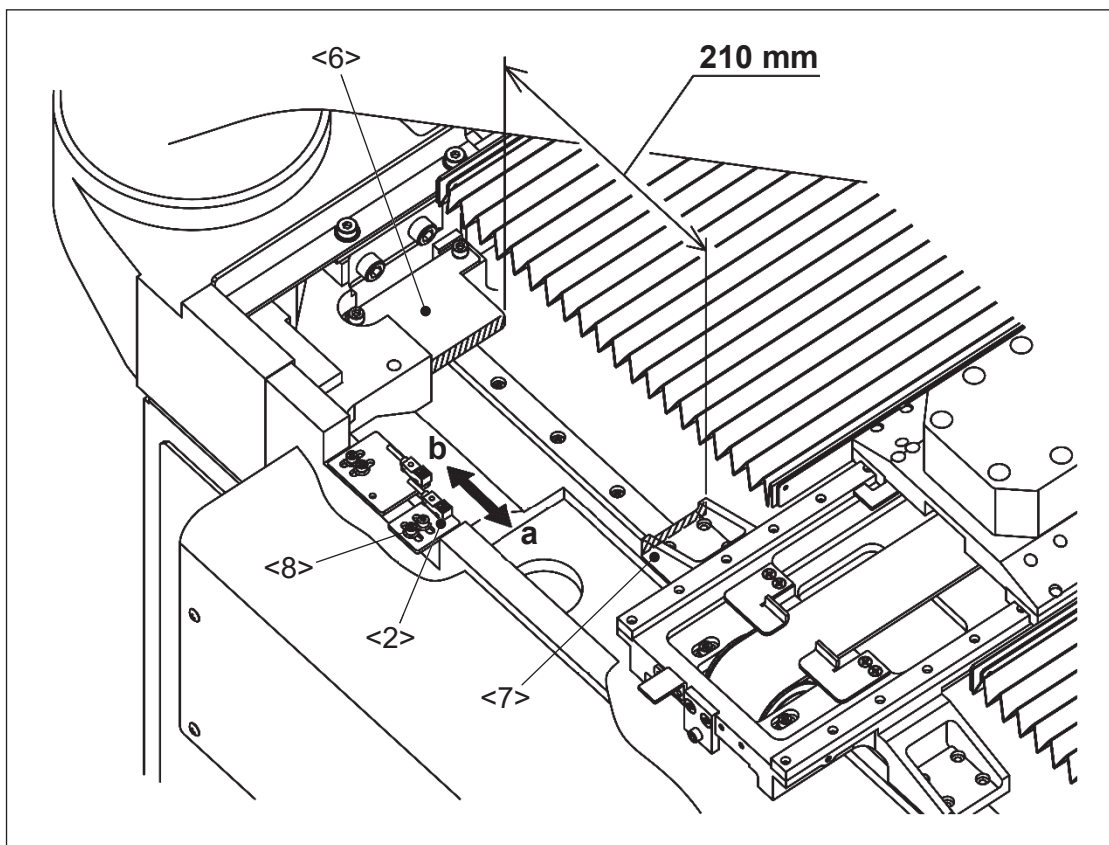

<2>: X detector <6>: X stopper <7>: Movable frame <8>: Screw

7-7-2. Adjustment of Y direction

(1) Turn the power switch on and press the home position return icon .

(2) Turn the power switch off when finish the origin return movement.

(3) Confirm the distance between Y stopper (No.10) and Y Movable race (No.9) which showing in hatched area is 120 mm. If different, loosen the two screws (No.8) of the Y detector (No.4) and adjust the detectors position. When above distance is more than 120 mm, move the Y detector (No.4) in arrow “b” direction. When less than 120 mm, move the Y detector (No.4) in arrow “a” direction.

(4) After adjustment, tighten the screw (No.8) and check again above (1) to (3) procedures.

(5) Confirm the clearance between detector and detect plate is in the range of 1 to 1.5 mm. If it has any damage with detector or the detect plate, this clearance may different.

NOTICE For the safety, turn the power switch off every time.

NOTE XY table mechanical home position is the center of the sawing area to the needle center. If modified the home position by control panel, please return the setting to default value in advance.

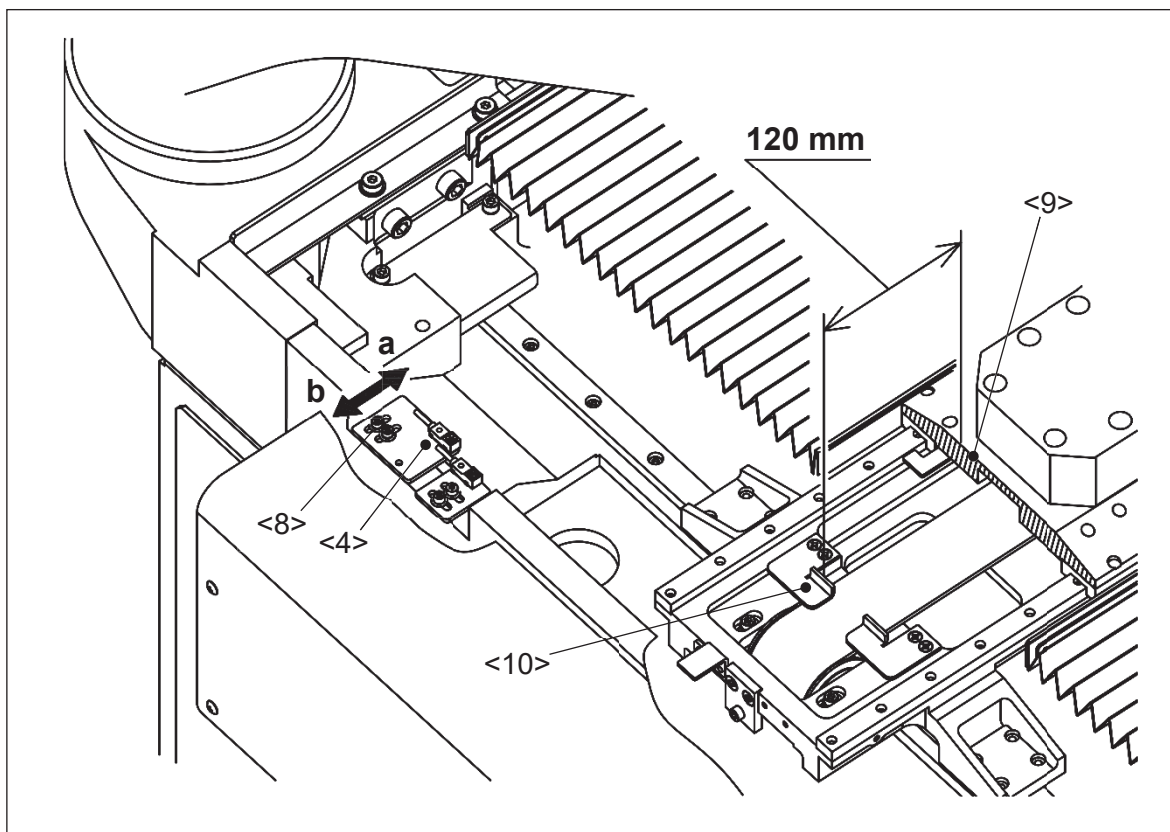

<4>: Y detector <8>: Screw <9>: Y movable race <10>: Y stopper

7-8. Adjustment of the Y timing belt tension

- (1) Remove the XY cover.
- (2) Loosen the two screws (No.1) of the pulley bracket.
- (3) Tighten the adjust screw (No.2), the timing belt (No.3) tension will be increased.
- (4) After the adjustment, tighten the screws (No.1).

Reference Y timing belt tension has been adjusted by 440 (N).

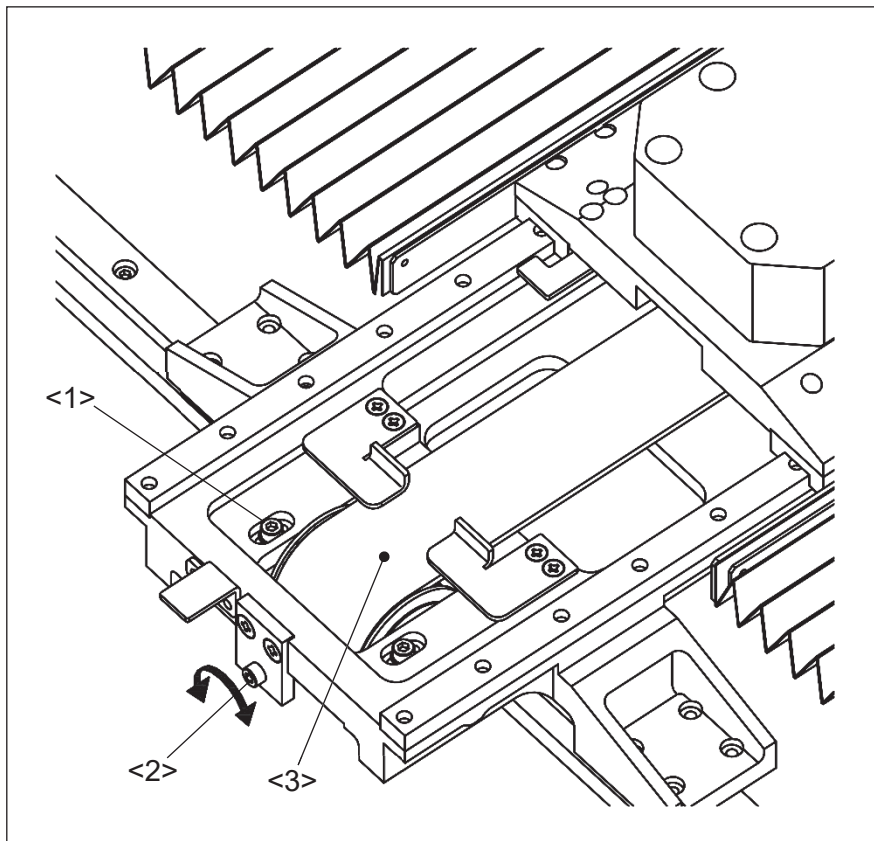

- <1>: Screw
- <2>: Adjust screw
- <3>: Timing belt

8. MAINTENANCE



- (1) Please make sure to turn the power switch off before cleaning the sewing machine.
- (2) Please pay attention to that staining your skin or eyes with oil may cause an inflammation.

8-1. Cleaning

- (1) Remove the dust and the thread waste sticking regularly.

8-2. Greasing

- (1) The dust or the like sticking absorbs lubrication oil on the rails and significantly lowers the slide guide running life. Remove the dust and the thread waste sticking regularly and greasing every six months.
- (2) For the guide rail, grease to the both side of guide groove. For the spline shaft and ball screw shaft, grease to the surface of shaft. After greased, apply the grease uniformly by moving the XY table by hand.

NOTE This operation required to removing the XY cover and shutter.

- <1>: X guide rail
- <2>: Y guide rail
- <3>: Spline shaft
- <4>: Ball screw shaft

Recommended grease: Lithium grease 2

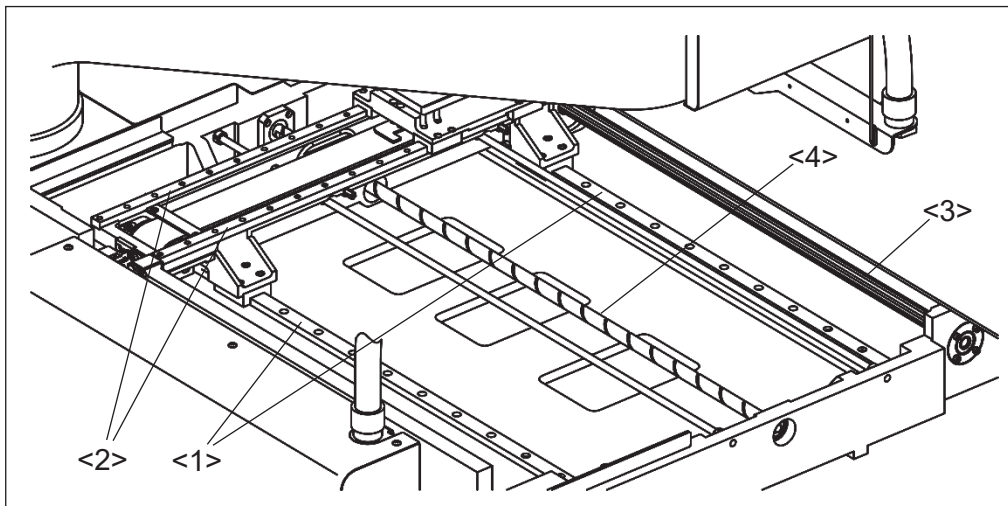

(3) Grease every six months to the following units which consisted by gear mechanism.

NOTE Remove the face cover and other covers in advance.

<5>: Rack gear which has presser foot unit.

<6>: Gear of the needle thread tensioner drive unit.

<7>: Sector gear of the hook rotating unit.

Recommended grease: Molybdenum disulfide grease

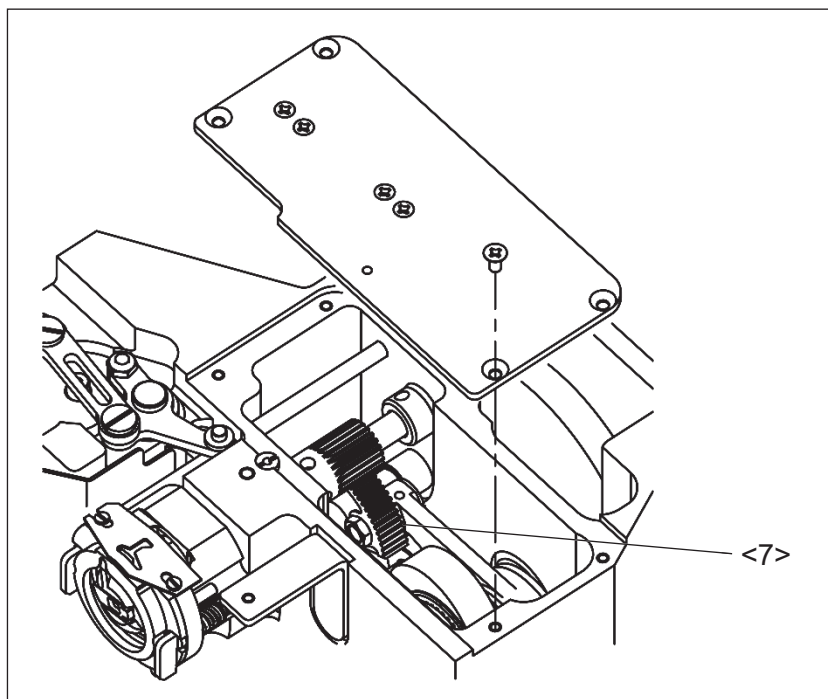
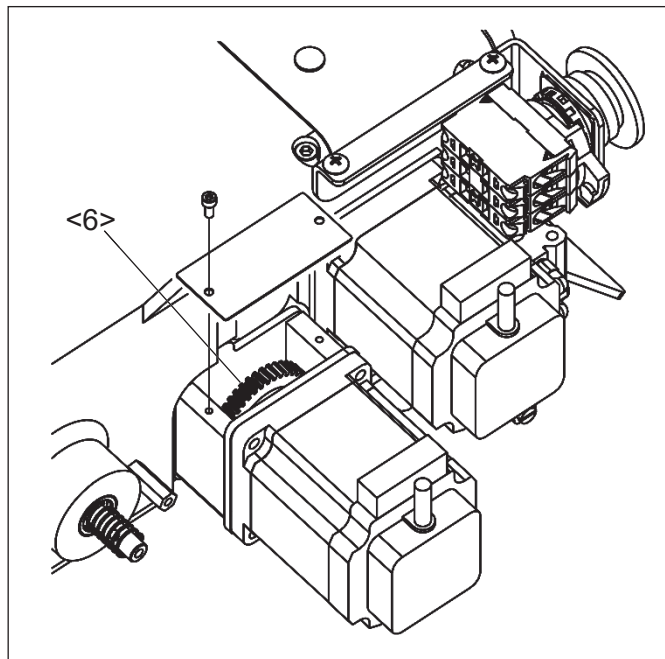
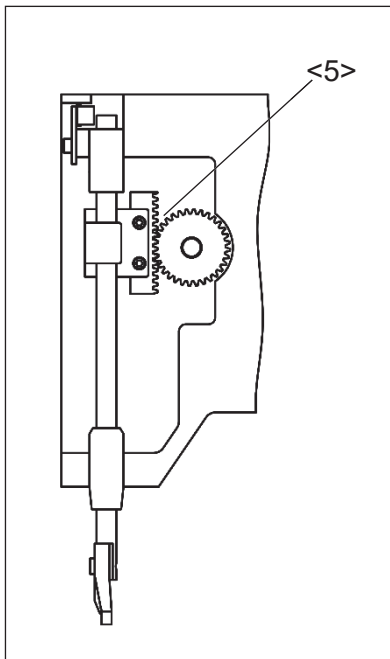

8-3. Disposing of oil waste

If the waste oil pan is full filled in the oil bottle (No.1), remove the oil bottle then dispose of the waste oil.

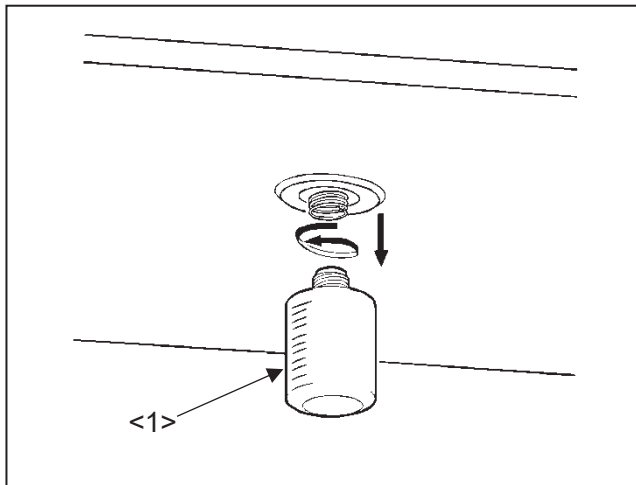

<1>: Oil bottle

9. TROUBLESHOOTING



CAUTION

(1) Please make sure to turn the power switch off before adjusting the sewing machine.

(2) If the adjustment is required while the power switch on, do not step on the foot switch by mistake.

Condition	Cause	Corrective action	Reference
Upper thread is broken.	Upper thread tension is too tight.	Adjust thread tension.	5-10
	Strength of thread take up spring is inappropriate.	Adjust thread take up spring.	6-6-2
	Parts on needle plate, hook, and presser foot touching thread are damaged.	Grind parts or change parts.	-
	The needle size is bigger than the thread size.	Change the needle size to suitable size.	5-1
	Thread melts with heat.	Slow down the sewing speed	Operation panel section
Use needle cooler.		-	
Bobbin thread is broken.	Bobbin thread tension is too tight.	Adjust thread tension.	5-9
	Parts on needle plate and presser foot touching thread are damaged.	Buff parts or change parts.	-
	Bobbin case size is smaller than the thread size.	Change the thread size to suitable size.	-
Upper thread is pulled from needle hole when starting sewing.	Thread take up spring tension is too much.	Adjust thread take up spring tension.	6-6-2
	Thread tail is short. (Pre-tensioner spring is too tight.)	Adjust thread tail with pre-tension.	6-7
	Sewing speed is inappropriate when starting sewing	Use [e-stitch] function. (Program mode > Sewing speed group > OPLC is ON)	Operation panel section

Frequent skip stitching happens.	Clearance between needle and hook is too big.	Adjust clearance between needle and hook properly.	6-2-3
	Timing of needle and hook is not proper.	Adjust position of needle and hook properly.	6-2-6
	Contact between needle and driver is too tight.	Adjust clearance between needle and driver properly.	6-2-4
	Needle is bent.	Change needle.	5-1
	Needle is at wrong position.	Fix position properly.	5-1
	Presser foot position is not proper.	Adjust presser foot position.	6-4
	Presser foot up and down timing is not proper.	Adjust presser foot up and down properly.	6-4
Trimming is not functioned.	Fixed knife is dull.	Sharpen fixed knife or change fixed knife.	-
	Movable knife is dull.	Sharpen Movable knife or change fixed knife.	-
	Movable knife home position is not proper.	Adjust movable knife home position.	7-5-1
	Skip stitching happens in trimming.	Refer to the condition "Frequent skip stitching happens".	-
	Setting of trimming timing is not proper	Adjust the trimming timing.	Operation panel section
	Trimming setting is off.	Turn trimming setting on.	Operation panel section
Needle thread is pulled from needle hole after trimming	Thread release timing is not proper.	Adjust the thread release timing.	Operation panel section
	Threading way of the needle thread is not proper.	Thread the needle thread properly.	5-2
	Pre-tensioner spring is too tight. (Thread tail is short.)	Adjust the intensity of the pre-tensioner spring.	6-7
Stitch forming is loose.	Upper thread tension is too loose.	Adjust upper thread tension.	5-10
	Bobbin thread tension is too loose.	Adjust bobbin thread tension.	5-9
	Strength of thread take up spring is inadequate.	Adjust strength of thread take up spring.	6-6-2

	Presser foot position is not proper.	Adjust presser foot position properly.	6-4
	Presser foot up and down timing is not proper.	Adjust presser foot up and down properly.	6-4
	Sewing material is not held	Hold the sewing material sufficiently.	-
Jig eject system does not work.	Foot switch is broken.	Change foot switch.	-
	Air presser is not strong enough	Increase air presser	6-8
Stitch on back comes apart.	Thread is not divided with thread guide properly.	Adjust thread guide position.	6-2-5
	Needle thread is too long.	Adjust needle thread with pre-tension.	6-7
Wiper system does not work.	Wiper hits needle or presser foot.	Adjust wiper position.	6-5
	Wiper setting is turned off.	Turn wiper setting on.	6-5
Sewing pattern is changed.	Work holder is not held by jig eject system.	Modify the cassette jig position.	5-7
	Sewing material in work clamp slips.	Put slip stopper on presser plate.	-
	Sewing material is too heavy.	Slow down sewing speed.	Operation panel section
	Y timing belt tension is loose.	Adjust timing belt tension properly.	7-8
Returned home position is changed.	Ambient temperature is out of use range.	Use sewing machine in ambient temperature in 5 degrees to 35 degrees.	-
	Clearance between detector and detecting subject is too wide.	Adjust clearance in 1 to 1.5mm.	7-7
Oil consumption is too much	Oil amount is too much.	Reduce the oil amount	6-3
Hook noise is loud	Oil amount is less	Increase the oil amount	6-3

10. APPENDIX

10-1. The positional relationship between the sewing area and jig eject system

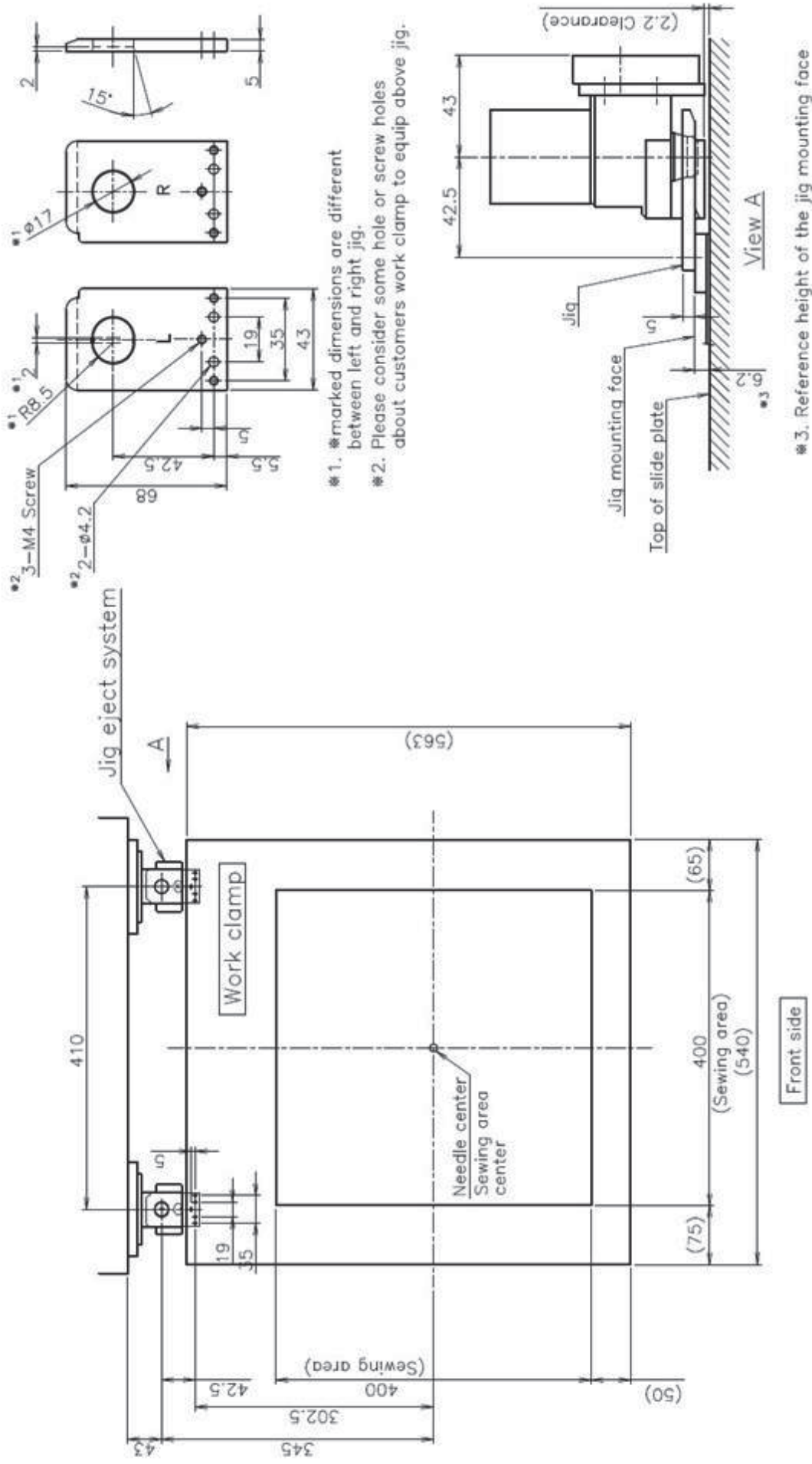

10-2. Air piping drawing

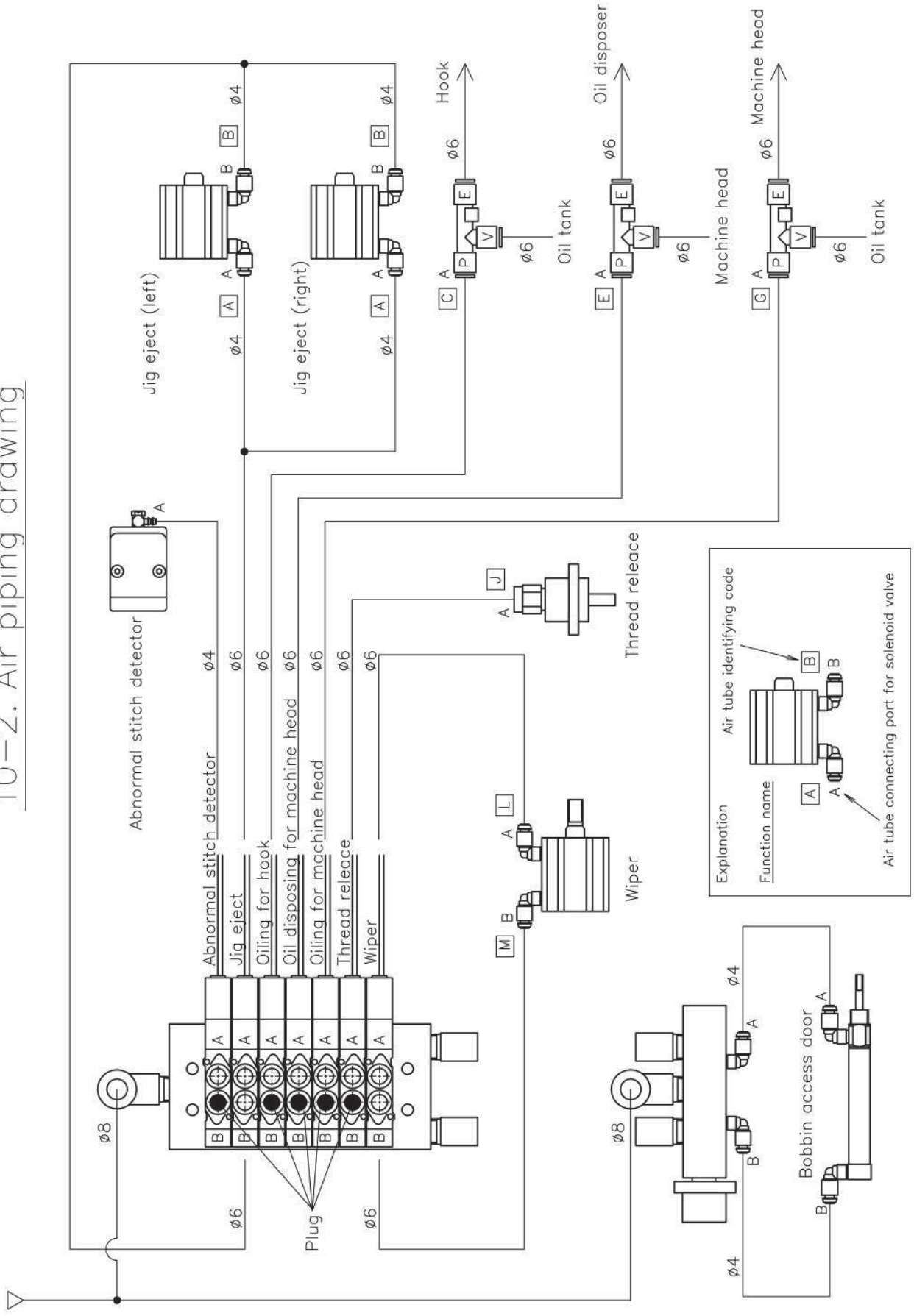

MEMO

A large rectangular area for writing, bounded by a solid line on the top and sides, and a solid line at the bottom. The interior of this area is filled with horizontal dashed lines, providing a guide for writing.

MEMO

A large rectangular area for writing, bounded by a solid line on the top and sides, and a solid line at the bottom. The interior of this area is filled with horizontal dashed lines, providing a guide for writing.

MEMO

A large rectangular area for writing, bounded by a solid line on the top and left, and a solid line on the bottom and right. The interior is filled with horizontal dashed lines, providing a guide for writing.

JUKI CORPORATION

Printed in Japan