

JUKI®

INDUSTRIAL SEWING MACHINE

MODEL

PLK-J2516R-YU

TECHNICAL MANUAL

SEWING MACHINE HEAD

FOR SAFE USE

Before the installation, operation, and inspection for this product, read the “FOR SAFE USE” and the technical manuals carefully. Also read the other technical manuals, “Control Unit” and “Operation Panel” describing some instructions, which are not in this manual, and use the sewing machine properly.

SAFETY INDICATIONS

	DANGER	Indicates that incorrect handling may cause hazardous conditions, resulting in death or severe injury.
	CAUTION	Indicates that incorrect handling may cause hazardous conditions, resulting in medium or slight personal injury or physical damage. Note that CAUTION level may lead to a serious consequence according to the circumstances. Always follow the instructions of both levels because they are important to personal safety.

CAUTION INDICATIONS

No.	Caution indication	Description
1		<p><u>Precaution for sewing machine operation:</u></p> <p>Indicates that removing the safety and operating the sewing machine for some other purposes with power-on are prohibited.</p> <ul style="list-style-type: none"> ● Please do not operate the sewing machine without protective equipment such as a needle guard, an eye guard, a belt cover or the others. ● Please turn off the power switch when threading, changing a needle and a bobbin, cleaning, and lubricating.
2		<p><u>Caution for fingers injury:</u></p> <p>Indicates a possibility of fingers (hands) injury in a certain condition.</p>
3		<p><u>Caution for squeezing fingers:</u></p> <p>Indicates a possibility of squeezing fingers in a certain condition.</p>

SAFETY PRECAUTIONS



To prevent from receiving an electric shock, always turn off a power switch and unplug power supply when opening a control box, and then open after ten minutes passes.



USAGE ENVIRONMENT

Please do not operate the sewing machine under the following conditions.

- (1) In the ambient temperature of 35 degrees (95°F) or more than 35 degrees, or the ambient temperature of 5 degrees or less than 5 degrees (41°F).
- (2) In the ambient temperature of 55 degrees (131°F) or more than 55 degrees, or the ambient temperature of -10 degrees or less than -10 degrees (18°F) during transportation.
- (3) In the relative humidity exceeding 85% or less than 45%.
- (4) In the open-air place or the location that receives direct sunlight.
- (5) In the place near heat sources such as heating devices.
- (6) In the atmosphere filled with dust, explosive gas, or corrosive gas.
- (7) In the place where the fluctuation in the power voltage of 10% or more than 10%, or the power voltage of -10% or less than -10% of the fixed power voltage.
- (8) In the place where the power source cannot supply enough voltage to keep the motor running.
- (9) In the place filled with strong electric noises such as high-frequency welders.

INSTALLATION

- (1) Please have some specialists, who have enough experience for the sewing machine installations, install the sewing machine.
- (2) Please have a qualified electrician perform necessary electric wiring.
- (3) Please do not operate until the sewing machine is repaired when any damage or fault is found on the sewing machine at the installation.
- (4) Please do not refurbish the sewing machine.
- (5) The sewing machine is heavy. For the safety, please make sure to install the sewing machine head by more than one person.
- (6) Please make sure to fit the safety protective equipment (the motor cover or the others) and the accessory protective equipment (the eye guard) that removed temporarily for installation.

SEWING

- (1) Please make sure to turn the power switch off before installing or replacing needles.
- (2) Please pay attention for the fingers not to be injured by the needle point.
- (3) Please make sure to turn power switch off before lubricating.
- (4) Please pay attention that oil does not get on your skin or in your eyes as it may cause an inflammation.
- (5) Please make sure to keep oil out of the reach of children who may drink oil by mistake.
- (6) Please make sure to turn the power switch off before threading a needle.
- (7) Before starting the sewing, please make sure the position and the function of the halt switch.
- (8) Please do not touch the operating parts during sewing operation.
- (9) It is very dangerous to operate the sewing machine without safety guards (eye guards, belt covers, link covers, finger guards or the others).
Please make sure to operate the sewing machine with safety guards.
- (10) Please make sure to turn the power switch off when stopping the sewing machine temporarily.

ADJUSTMENT

- (1) Please make sure to turn the power switch off before adjusting the sewing machine.
- (2) If the adjustment is required while the power switch on, do not step on the foot switch by mistake.
- (3) Please be careful not to be injured by a sharp part such as the needle and the shuttle hook point.
- (4) Please make sure to put the safety guards (eye guards, belt guards, link covers, and finger guards or the others) back on the initial position after the sewing machine adjustment.

CONTENTS

1. STRUCTURE OF THE SEWING MACHINE	1
2. SPECIFICATIONS	2
3. INSTALLATION	3
3-1. Preparation of the table	3
3-2. Preparation of the steel stand	4
3-3. Installation of the control box	4
3-4. Installation of the operation panel	4
3-5. Installation of the power switch and foot switch	4
3-6. Installation of the oil pan	5
3-7. Installation of the machine head	5
3-8. Installation of gas spring	6
3-9. Installation of the tilting detect switch	7
3-10. Connection of the electric cables	8
3-10-1. How to remove the motor cover	9
3-10-2. Connection of the PF axis cables	9
3-10-3. Connection of the XY axis cables	10
3-10-4. Connection of the main servo cables	11
3-10-5. Connection of the I/F board cables	12
3-10-6. Connection of the optional output connector	13
3-10-7. Fixing of the cables	13
3-11. Connection of the air tube	14
3-11-1. Installation of the filter regulator and air piping	14
3-11-2. Piping of the oil drainage tube	15
3-12. Installation of the thread stand	17
3-13. Installation of the eye guard	17
4. LUBRICATION	18
4-1. Filling the oil tank	18

5. PROPER OPERATION	19
5-1. Setting of the main servo motor upper positon	19
5-2. Installation of the needle	21
5-3. Threading the needle thread	22
5-4. Winding the bobbin thread	23
5-5. Setting the bobbin	24
5-6. Setting the bobbin case	24
5-7. Operation of the halt switch	25
5-8. Adjustment of the thread tension	25
5-9. Adjustment of upper thread tension	26
6. STANDARD ADJUSTMENT	27
6-1. Adjustment of the needle bar position	27
6-2. Adjustment of the position between the needle and the rotating hook	28
6-3. Adjustment of the hook positioner's position	30
6-4. Adjustment of the oil lubrication for the rotating hook	31
6-5. Adjustment of the oil lubrication for the machine head	32
6-6. Setting of the presser foot movement	33
6-7. Adjustment of the wiper	33
6-8. Adjustment of the thread take up spring	34
6-8-1. Adjusting movable range of the thread take up spring	34
6-8-2. Adjusting intensity of the thread take up spring	34
6-9. Adjustment of the thread tail after the trimming	35
6-10. Adjustment of the air pressure	35
6-11 Changing the work holder	36

7. VARIOS ADJUSTMENT	37
7-1. How to exchanging the tension spring of the needle thread tensioner unit	37
7-2. Adjustment of the detector position of the presser foot unit	39
7-3. How to replace with a special pressor foot	42
7-4. Adjustment of the pressor foot holder position	45
7-5. Adjustment of the thread trimmer	46
7-5-1. Structure of the thread trimmer mechanism	46
7-5-2. Assembling and readjustment of the thread trimmer mechanism	46
7-5-2.1 Attaching the knife bracket and the knife mounting unit	46
7-5-2.2 Mutual relation among the movable and stationary knife edge	47
7-5-2.3 Connection of the knife bracket and the driving crank	48
7-5-2.4 Adjustment of the component parts of the knife driving mechanism	48
7-5-2.5 Adjustment of the mounting position of the air cylinder	49
7-5-2.6 Adjustment of the mounting position of the thread trimmer cam	49
7-5-2.7 Adjustment of the knife engagement	51
7-6. Adjustment of the X-Y table detector	53
7-6-1. Adjustment of the X-Y mechanical home position	53
7-6-2. Adjustment of the X direction	54
7-6-3. Adjustment of the Y direction	55
7-6-4. The X-Y drive timing belt tension	55
8. MAINTENANCE	56
8-1. Cleaning	56
8-2. Greasing	56
8-3. Disposing of oil waste	57
9. TROUBLESHOOTING	58
10. APPENDIX	
10-1. Air piping drawing	
10-2. Steel stand drawings	

1. STRUCTURE OF THE SEWING MACHINE

PLK-J2516R-YU sewing machine consists of the following main parts.

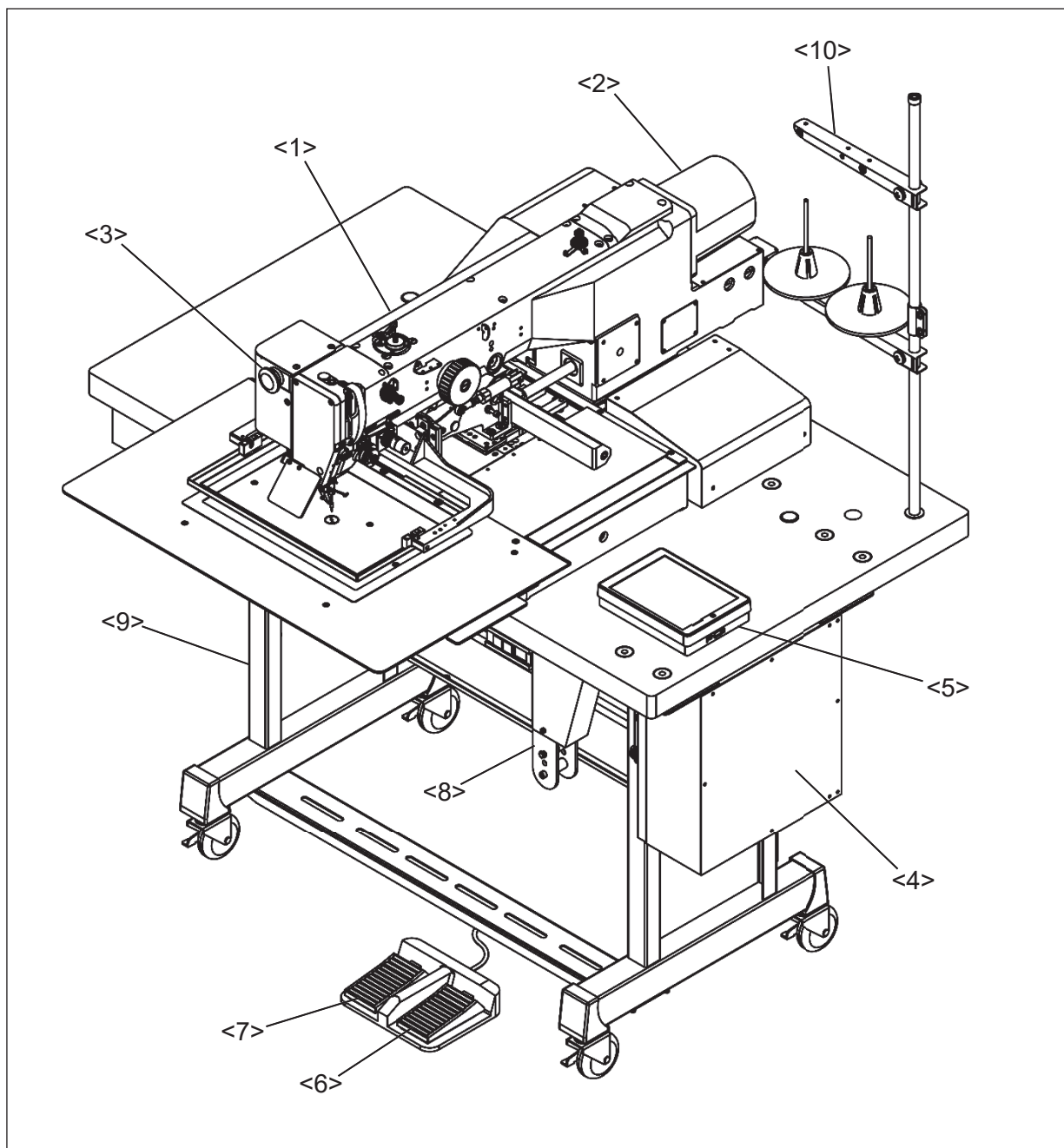

<1>: Sewing machine head <2>: Main shaft motor <3>: Halt switch <4>: Control box
<5>: Operation panel <6>: Work holder switch <7>: Start switch <8>: Gas spring
<9>: Steel stand <10>: Thread stand

2. SPECIFICATIONS

Model	PLK-J2516R-YU
Stitch type	Single needle lock stitch
Hook	Double size rotating hook
Class of needle	DPX17#18
Sewing area	X-direction (left/right) 300 mm
	Y-direction (front / back) 200 mm
Maximum sewing speed *1	2,300rpm (Continuous feeding) 2,300rpm (M3 feeding)
Setting speed	10 speed levels in 200 rpm to 2,300 rpm (M3 feeding)
Stitch length	0.1 to 20.0 mm (min. resolution 0.1 mm)
Maximum number of needles	20,000 per pattern
Storable sewing data item	9,000 patterns *2
Data memory	USB memory
Type of motor	750W direct servo motor
Work holder lift	30 mm
Needle bar stroke	40.0 mm
Thread take up lever stroke	73.0 mm
Presser foot drive	Direct drive by stepping motor
Presser foot lift	18.0 mm (max. 24.0 mm) Variable in 0.1 mm step
Presser foot stroke *3	Digital adjustment stroke: 0.1 to 10.0 mm
Upper thread tensioner	Manual / Automatic / Setting on pattern (switchover)
Wiper system	Back to front wiping system
Oil lubrication	Replenishment with the oil braids from the oil tanks. Spray method (Inside of the sewing machine head only).
Operation panel	6.5-inch color LCD touch panel with USB port
External device I/F	USB port, Terminal I/O: 16 input, 16 output
Thread trimmer system	Arc engagement with fixed knife and movable knife
Machine dimensions (W)x(L)x(H)	1,200mm x 1,144mm x1,230mm
Weight	187kg
Power	In 200V to 240V single-phase or three-phase

*1: Sewing speed may be limited by the operation or sewing condition.

*2: The max. patterns may be limited depending on the number of stitches of each pattern in the memory.

*3: Standard value is 8.0 mm.

3. INSTALLATION



- (1) Please have some specialists, who have enough experience for the sewing machine installations, install the sewing machine.
- (2) Please have a Qualified Electrician perform necessary electric wiring.
- (3) Please do not operate until the sewing machine is repaired when any damage or fault is found on the sewing machine at the installation.
- (4) Please do not refurbish the sewing machine.

3-1. Preparation of the table

- (1) If the table is not original, the thickness of the table is required to have 40mm and that is strong enough to withstand the weight and Vibration of the sewing machine.
- (2) Manufacture the table as shown on the figure below.

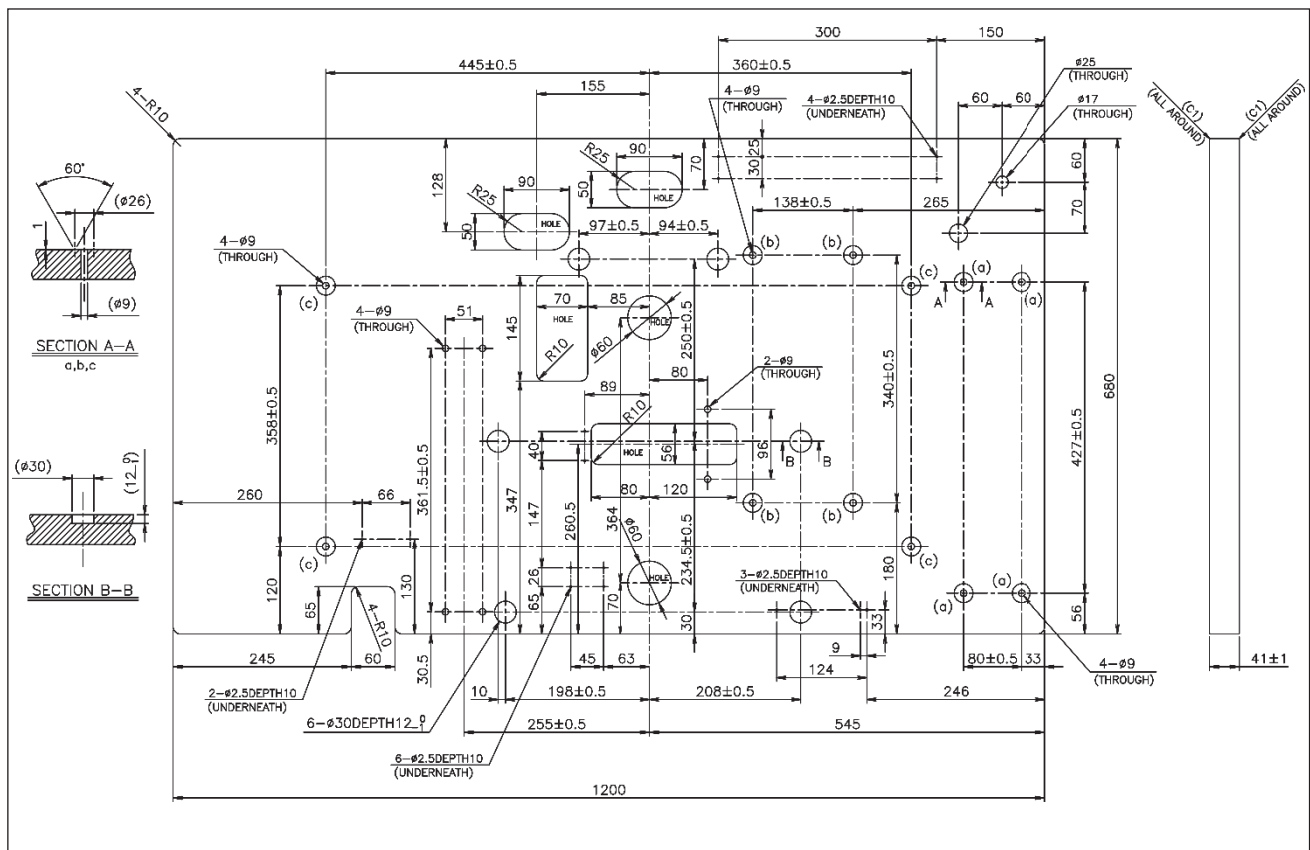

3-2. Preparation of the steel stand

- (1) If the steel stand is not original, please refer to the dimensions shown on the figure at the right.
- (2) When fitting the caster to the steel stand, the steel stand has to be strong enough to withstand the weight and vibration of the sewing machine.
- (3) If the steel stand is PLK-J2516R-YU original, assemble the steel stand with the assembling instructions enclosed in the packing.

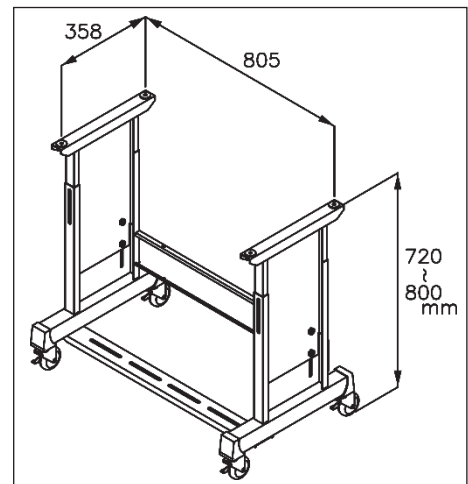

3-3. Installation of the control box

Install the control box with the instructions in the paragraph “[3] Installation” in the **CONTROL UNIT** technical manual.

3-4. Installation of the operation panel

Connect the operation panel PLK-G-PAL with the CON G on the rear of the control box.

3-5. Installation of the power switch and foot switch

- (1) Mount the power switch (No.1) with the wood screw (No.2) at the position as shown on the figure.
- (2) Hook up the connector (No.3) of the power switch to the control box CON F.
- (3) Attach the power plug (No.5) to the incoming electrical cable (No.4).
- (4) Fix the electric cables with the staples (No.6) to prevent the cables from hanging down.
- (5) Hook up the connector (No.8) of the foot switch (No.7) to the control box CON L.
- (6) As for the control box connector, refer to the instructions in the paragraph “3-10.Connection of the electric cables” in this manual.

NOTICE Power plug (No.5) is not included in accessory box.

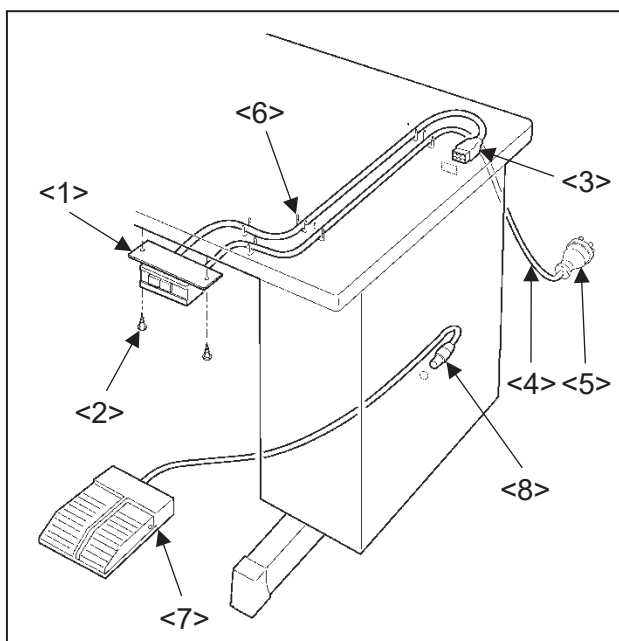

- <1>: Power switch
- <2>: Wood screw
- <3>: Power switch connector
- <4>: Electrical cable
- <5>: Power plug
- <6>: Staple (six staples)
- <7>: Foot switch
- <8>: Foot switch connector

3-6. Installation of the oil pan

- (1) Remove the oil pan (No.1) from the accessory box then, set the oil bottle (No.2) to the oil pan (No.1).
- (2) Put the oil pan at the position shown on the figure then, fix the oil pan with staples (No.3).
- (3) Set the damper cushions (No.4) to the table.

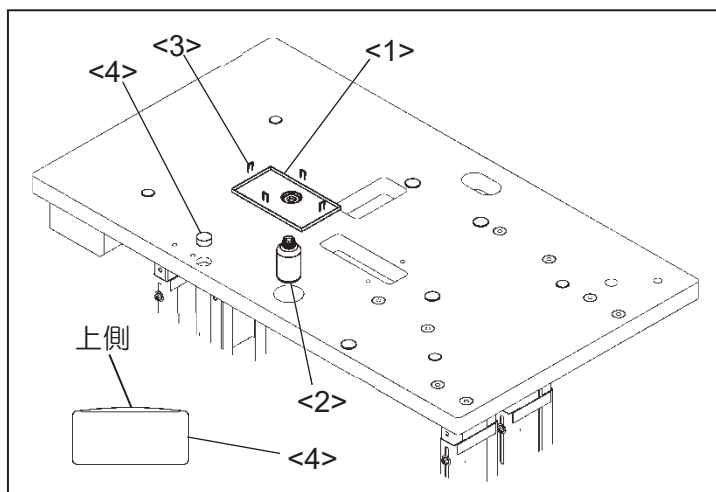

- <1>: Oil pan
- <2>: Oil bottle
- <3>: Staple (four staples)
- <4>: Damper cushion
(six cushions)

3-7. Installation of the machine head

⚠ CAUTION

- (1) The sewing machine is heavy. For the safety, please make sure to install the sewing machine head by more than one person.
- (2) When tilting the sewing machine, please stand at the hinge side and hold the sewing machine with both hands. Also, please lock the caster on the steel stand.
- (3) When tilting the sewing machine, the work clamp slides toward the hinges. Remember to move the work clamps fully to the right side of the table and attach the stopper before tilting the sewing head.

- (1) Put the machine head carefully on the damper cushion.
- (2) Insert the hinge shafts (No.1) into the hole on the machine and fix with set screws (No.2).
- (3) Fit the hinge rubbers (No.4) and the support plates (No.5) into the holes of the hinges (No.3) then, set the hinges to the hinge shafts.
- (4) Fit the screw holes of the hinges (No.3) to the bolt setting holes then, fix the machine with the socket bolts (No.6) and the flat washers (No.7).

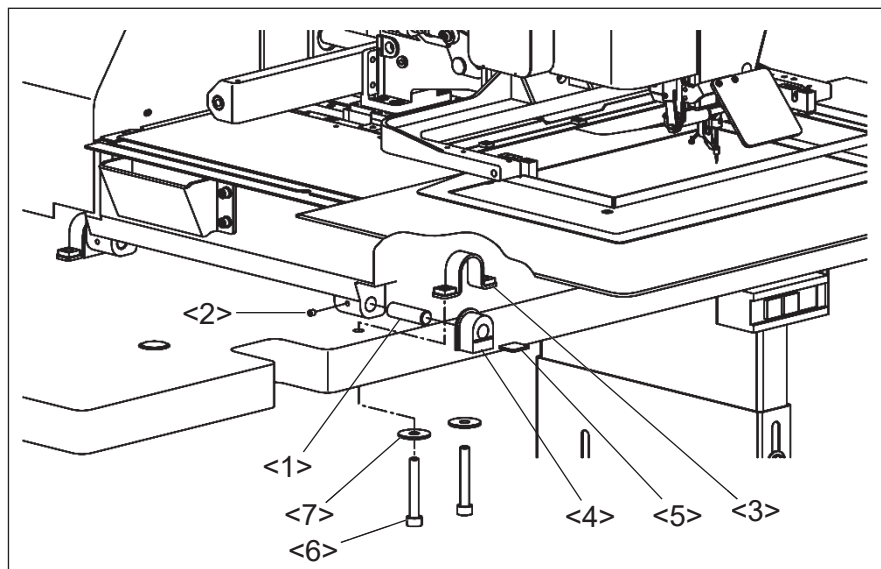

- <1>: Hinge shaft (two shafts)
- <2>: Set screw (two screws)
- <3>: Hinge (two hinges)
- <4>: Hinge rubber (two rubbers)
- <5>: Support plate (two plates)
- <6>: Socket bolt (four bolts)
- <7>: Flat washer (four washers)

3-8. Installation of gas spring



DANGER

- (1) The sewing machine is heavy. For the safety, please make sure to install the sewing machine head by more than one person.
- (2) When tilting the sewing machine, please stand at the hinge side and hold the sewing machine with both hands. Also, please lock the caster on the steel stand.
- (3) When tilting the sewing machine, the work clamp slides toward the hinges. Remember to move the work clamps fully to the right side of the table and attach the stopper before tilting the sewing head.

- (1) Before tilting the sewing machine, insert the accessory stopper (No.1) into the hole of work clamp to prevent the sliding of work clamp.
- (2) Set up the gas spring unit (No.2) on the sewing table, and temporarily fix it with the socket bolts (No.3), the flat washers (No.4 & 5), and the nuts (No.6) so that it can be still movable.
- (3) Fit the holes of the gas spring head side to the bracket (No.7) hole then, insert the shaft (No.8).
- (4) Attach the snap pin (No.10) and the flat washer (No.9).
- (5) Adjust the position of the gas spring unit (No.2) when the machine head returned to the initial position. Fix the gas spring unit not to be inclined when the machine head is in initial position.
- (6) After install the gas spring unit, remove the stopper (No.1).

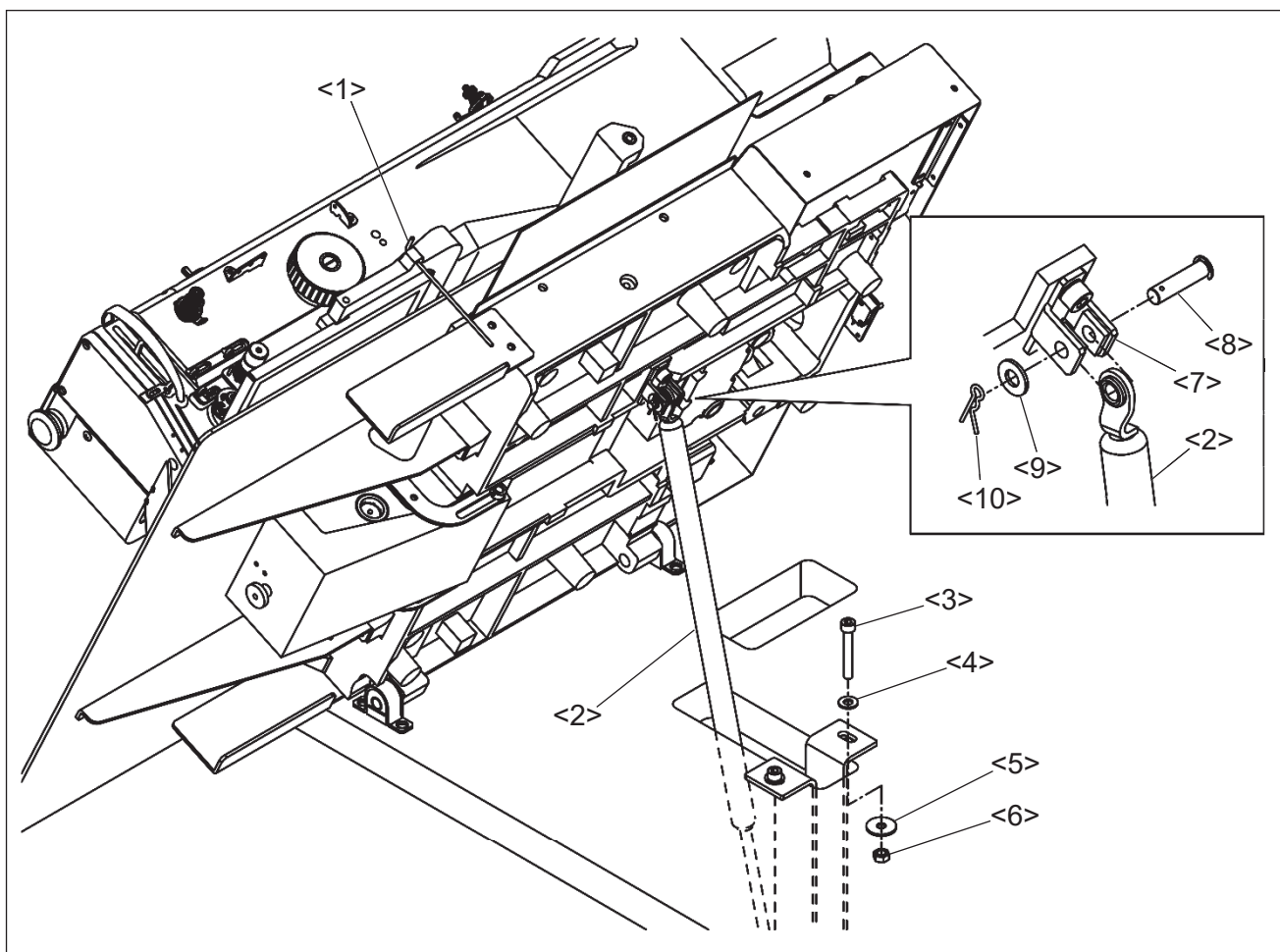

- <1>: Stopper <2>: Gas spring unit <3>: Socket bolt (two bolts) <4>: Flat washer (two washers)
<5>: Flat washer (large) (two washers) <6>: Nut (two nuts) <7>: Bracket <8>: Shaft
<9>: Flat washer <10>: Snap pin

(7) Attach the cover (No.11) to the gas spring unit with the screws (No.12).

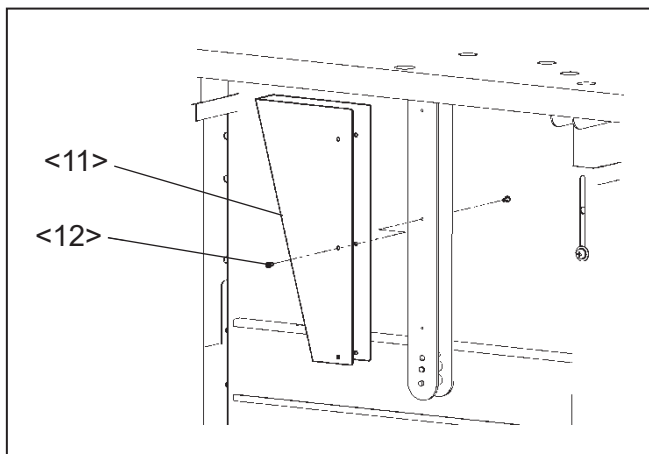

<11>: Cover
<12>: Screw (six screws)

3-9. Installation of the tilting detect switch

(1) Install the switch units (No.1) with the Screws (No.2).

(2) Adjust the switch units (No.1) position so that the machine table push the switch when the machine head in initial position and turns on the switch.

NOTE The switch unit (No.1) is temporarily fixed at the back side of the sewing machine bed. Fix it to the proper place as shown on the below figure.

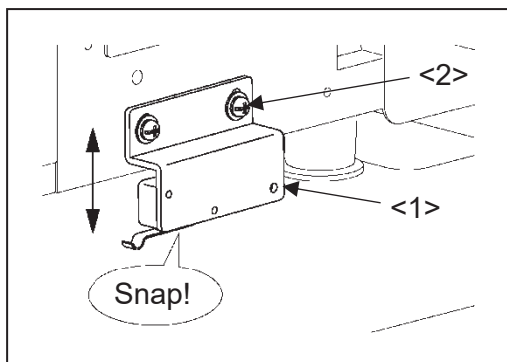

<1>: Switch units
<2>: Screw (two screws)

NOTICE if the switch is not turned on, error [M-038] will occur.

3-10. Connection of the electric cables

⚠ CAUTION

(1) Please make sure to ground the place where there is a  mark. Failure to do so may cause electric shock and/or malfunction.

Connect the machine head and the control box with cables as following below instruction.

Connect each connector fully to ensure sufficient contact.

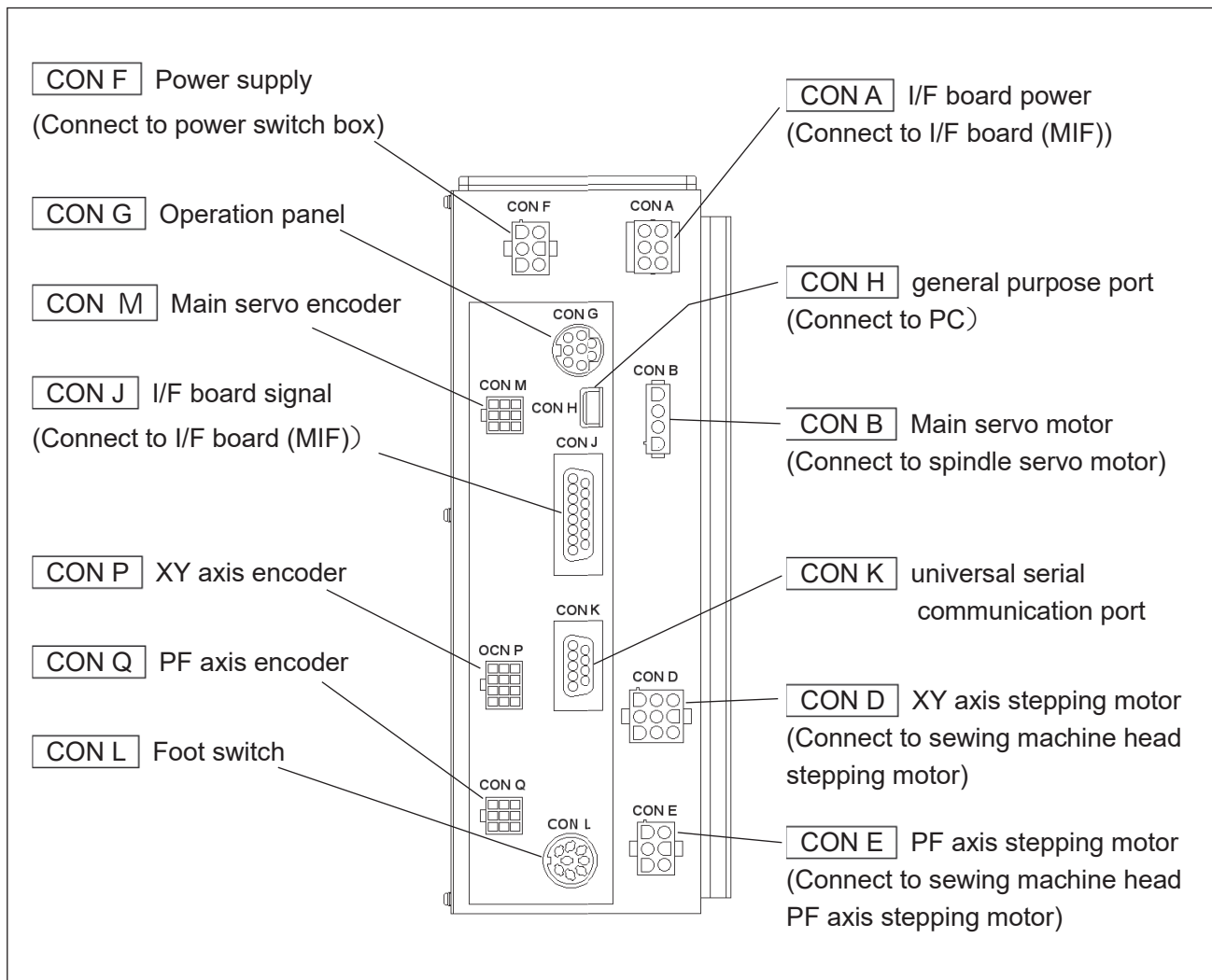

3-10-1. How to remove the motor cover

(1) Remove the five of screws (No.2) and remove the motor cover (No.1).

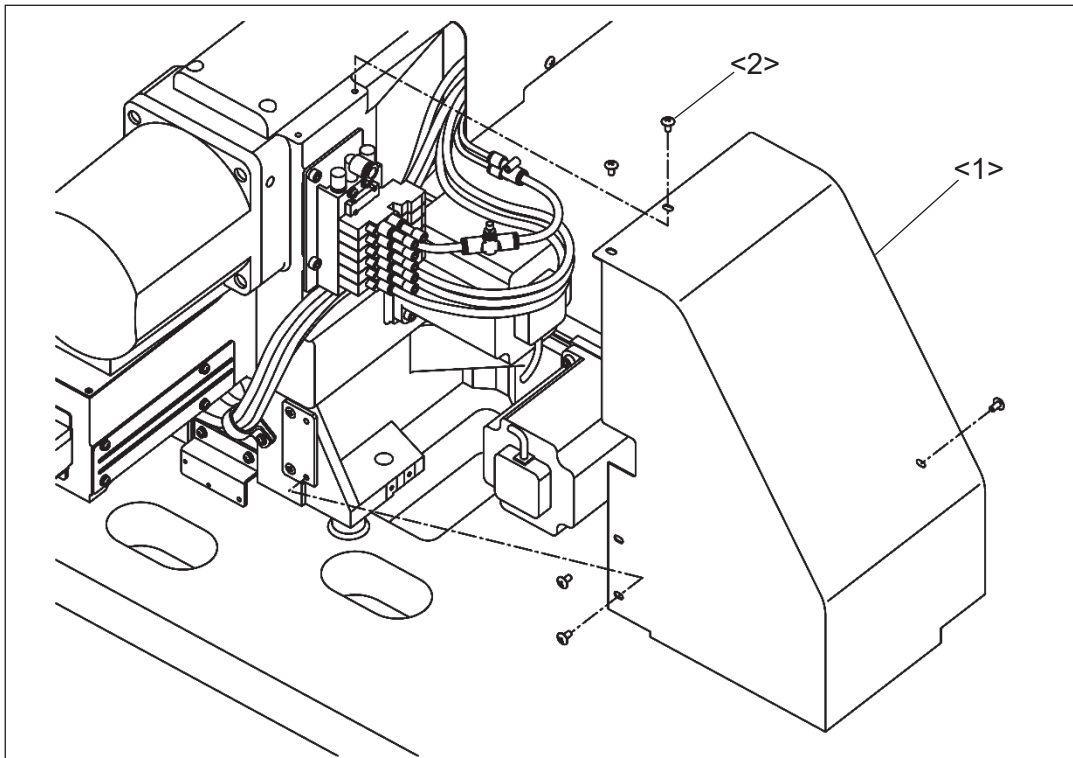

<1>: Motor cover <2>: Screw

3-10-2. Connection of the PF axis cables

(1) Prepare the PF axis motor cable (No.1) and PF axis encoder cable (No.2) which housed in the motor cover and wiring that to the back side of the table by passing through the square hole.

(2) Connect each of the PF axis motor cable (No.1) and PF axis encoder cable (No.2) to CON E and CON Q connector which has control box. Please refer to previous paragraph [3-10. Connection of the electric cables] for detail of connector position.

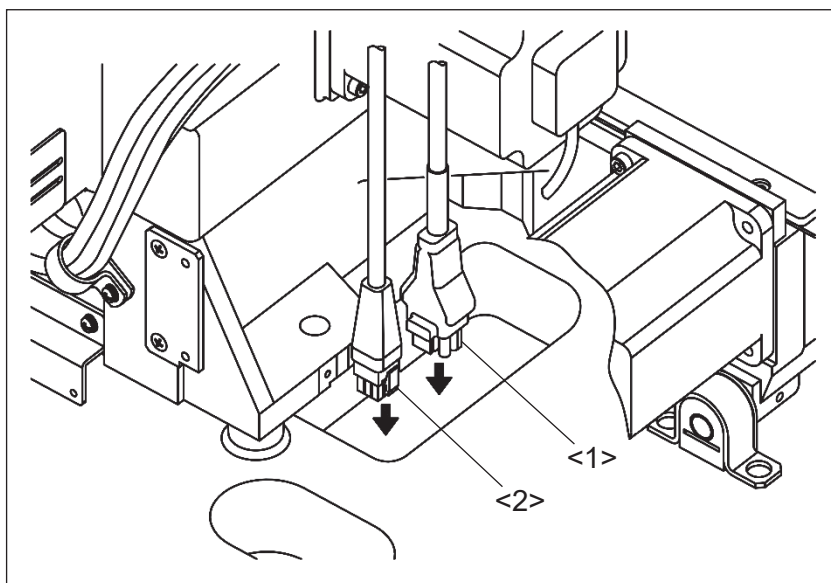

<1>: PF axis motor cable <2>: PF axis encoder cable

3-10-3. Connection of the XY axis cables

- (1) Install the XY motor cable (No.1) to the sewing machine with nylon clip FG (No.3) and screw (No.4) which are enclosed in accessory box.
- (2) Install the XY encoder cable (No.2) to the sewing machine with nylon clip (No.5) and screw (No.6) which are enclosed in accessory box.
- (3) Connect each of the XY axis motor cable (No.1) and XY axis encoder cable (No.2) to the each cable of machine motor.

NOTICE The cable connector has X, Y difference. When connecting the cable, match the connectors identify mark shown in each connector.

- (4) Connect each of the XY axis motor cable (No.1) and XY axis encoder cable (No.2) to CON D and CON P connector which has control box. Please refer to previous paragraph [3-10. Connection of the electric cables] for detail of connector position.

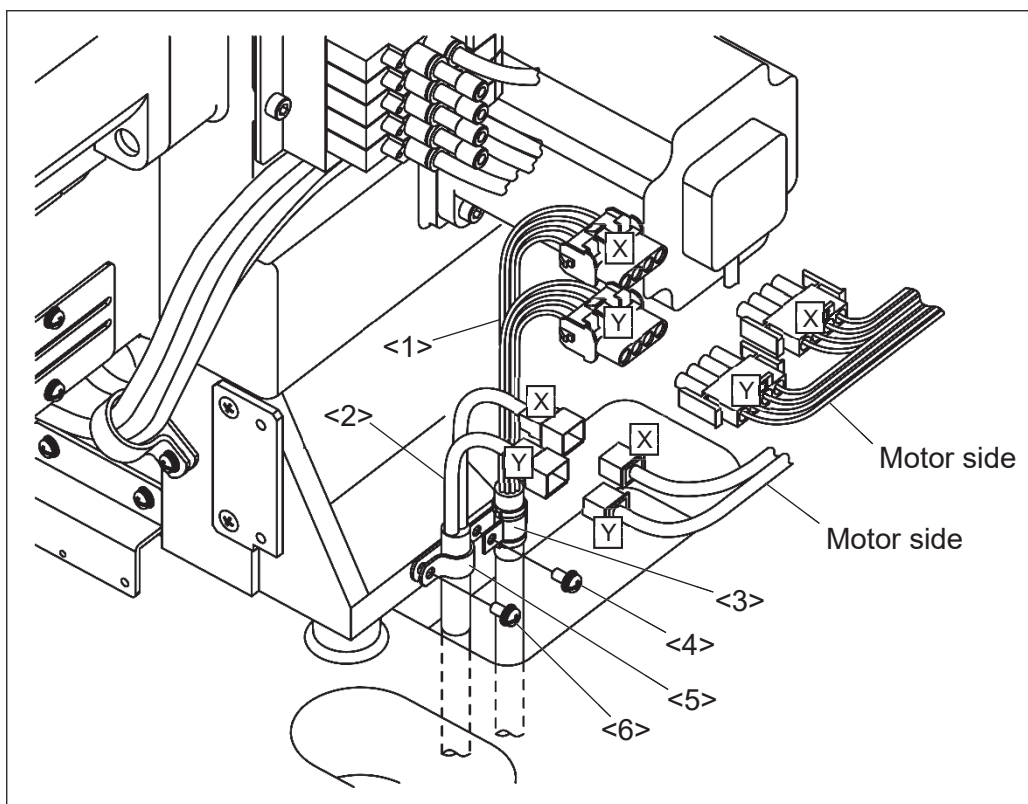

- <1>: XY axis motor cable <2>: XY axis encoder cable
<3>: Nylon clip FG <4>: Screw <5>: Nylon clip <6>: Screw

3-10-4. Connection of the main servo cables

- (1) Wiring the main servo motor cable (No.1) and main servo encoder cable (No.2) to the back side of the table by passing through the long hole.
- (2) Connect each of the main servo motor cable (No.1) and main servo encoder cable (No.2) to CON B and CON M connector which has control box. Please refer to previous paragraph [3-10. Connection of the electric cables] for detail of connector position.

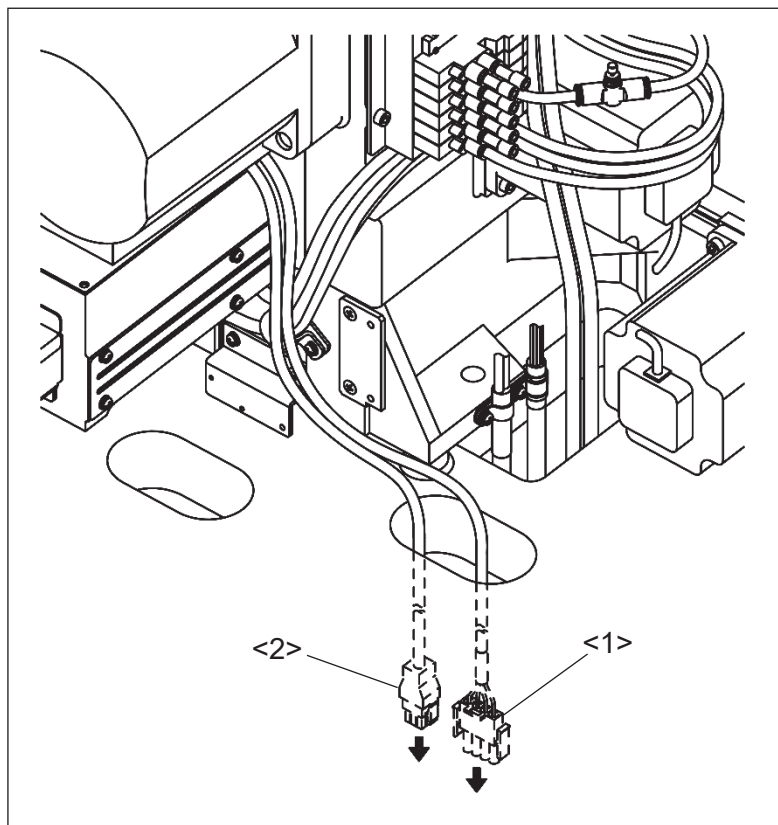

<1>: Main servo motor cable
<2>: Main servo encoder cable

3-10-5. Connection of the I/F board cables

- (1) Connect the I/F board signal cable (No.1) to the I/F board connector which enclosed in accessory box.
- (2) Connect the I/F board power cable (No.2) to the I/F board connector which enclosed in accessory box.
- (3) Wiring the I/F board signal cable (No.1) and I/F board power cable (No.2) to the back side of the table by passing through the long hole.
- (4) Connect each of the I/F board signal cable (No.1) and I/F board power cable (No.2) to CON J and CON A connector which has control box. Please refer to previous paragraph [3-10. Connection of the electric cables] for detail of connector position.

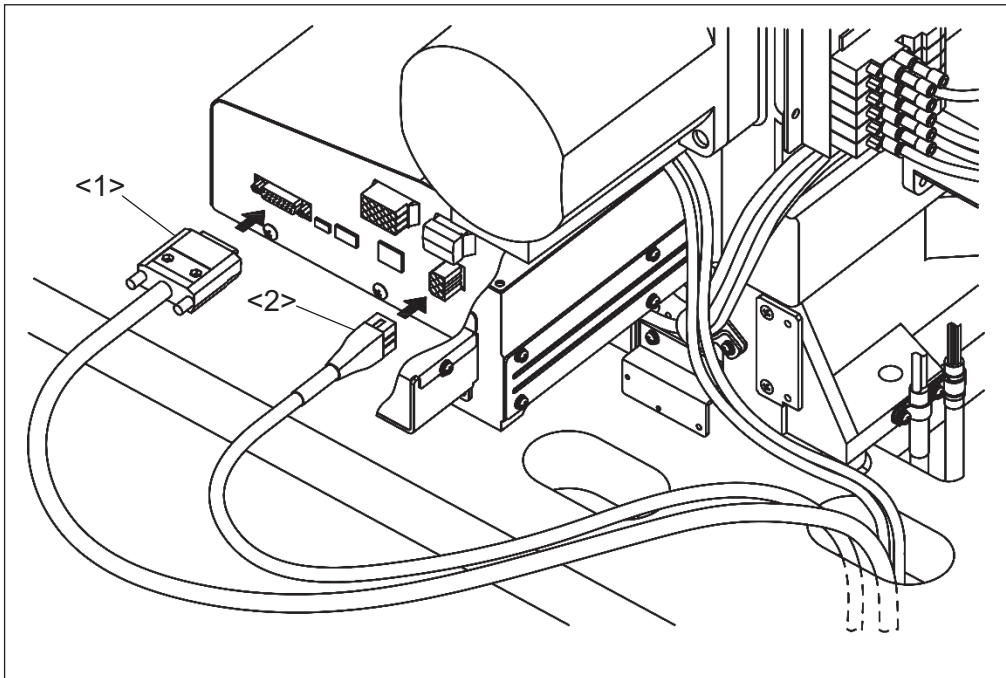

<1>: I/F board signal cable <2>: I/F board power cable

3-10-6. Connection of the optional output connector

(1) Connect the optional output connector (No.1) to the I/F board connector.

NOTE If not connected this connector, the oil discharging function does not work.

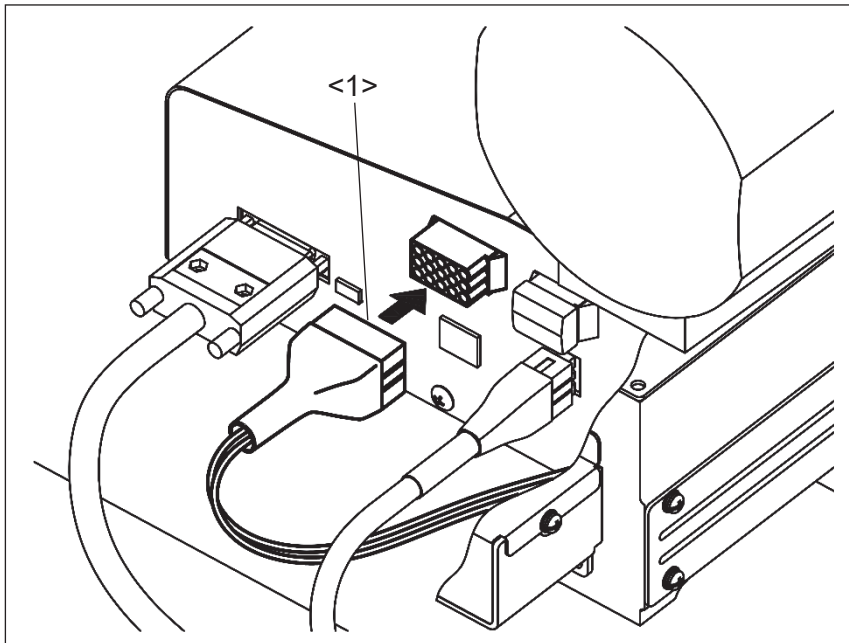

<1>: Optional output connector

3-10-7. Fixing of the cables

(1) Attach the two of tie holders (No.1) with wood screws (No.2) which enclosed in accessory box. There are wood screw prepared holes for the tie holders (No.1) on the rear surface of the table.

(2) Insert the cord tie (No.3) to the tie holder (No.1) and fix the cables as shown in the below figure. At this time, please make any allowance for the machine side cables so as not to pull the cables when tilting the sewing machine.

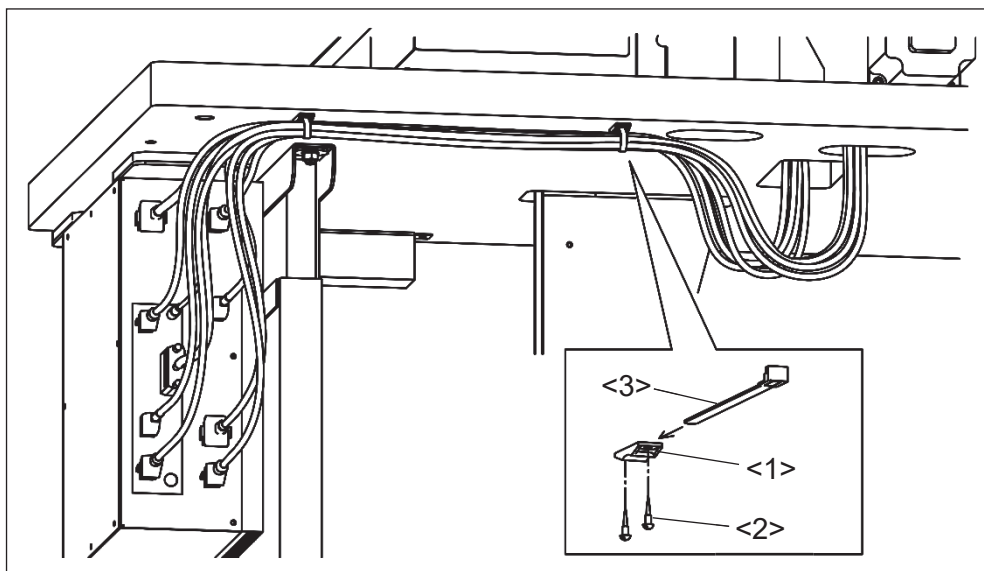

<1>: Tie holder <2>: Wood screw <3>: Cord tie

3-11. Connection of the air tube

3-11-1. Installation of the filter regulator and air piping

(1) Attach the air presser regulator assembly (No.1) underneath the table with the wood screws (No.2).

The prepared holes are provided for the wood screws on the rear surface of the table.

(2) Cut the part of size $\phi 8$ air tube (No.3) enclosed in the accessory box into about 1 meter length then, insert one end of this air tube into the intake air fitting (No.8) of the magnet valve assembly (No.7) The magnet valve assembly (No.7) is located at the left side surface of the sewing machine head. Beside, pass the other end of the air tube (No.3) through the cut out hole of the table top then, insert it into the air outlet fitting (No.5) of the air presser regulator (No.1).

(3) Insert the one end of the resting air tube into the intake air fitting (No.4) of the air coupling to be adopted with the air supply source provided in your factory. One of the air couplings (No.6) is enclosed in the accessory box.

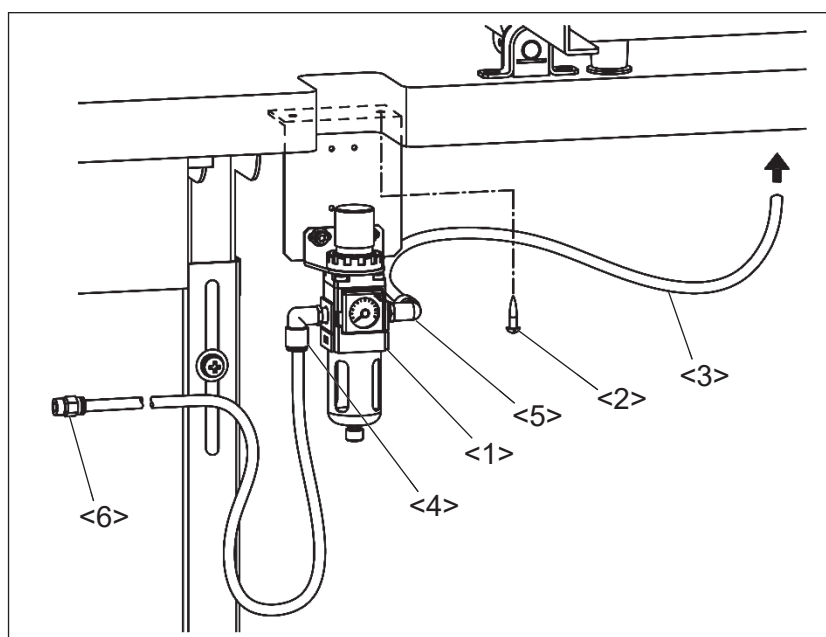

- <1>: Air presser regulator unit
- <2>: wood screw (two screws)
- <3>: Air tube (size $\phi 8$)
- <4>: Intake air fitting
- <5>: Air outlet fitting
- <6>: Air coupling
- <7>: Magnet valve assembly
- <8>: Intake air fitting

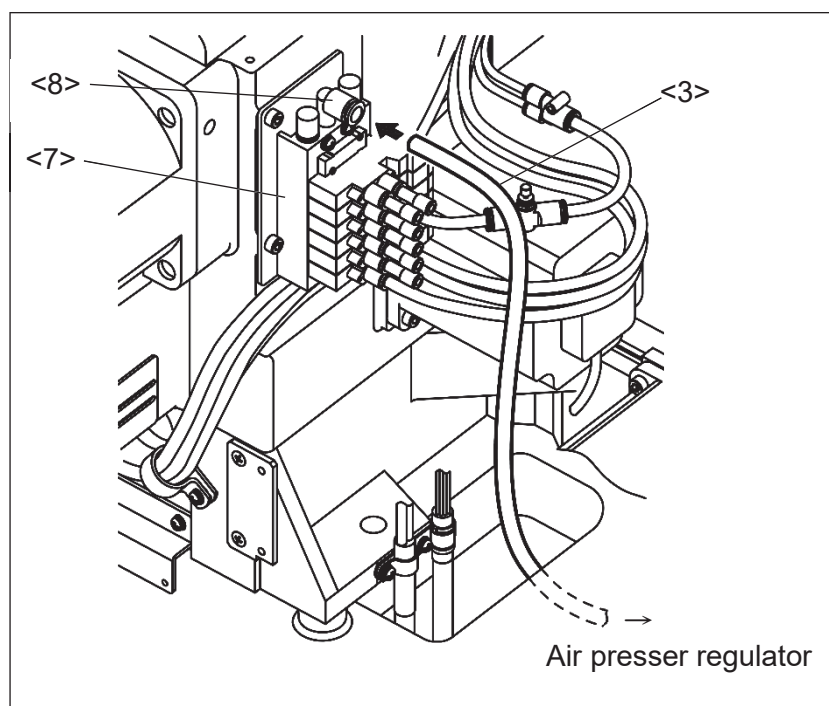

3-11-2. Piping of the oil drainage tube

According to following procedures, piping the oil discharging unit which is capable of reducing the excess of lubrication oil.

- (1) Prepare the oil drainage tube (No.3) which connected with air ejector (No.2) which is also connected with magnet valve assembly (No.1). The oil drainage tube (No.3) is housed in the motor cover in bundled state.

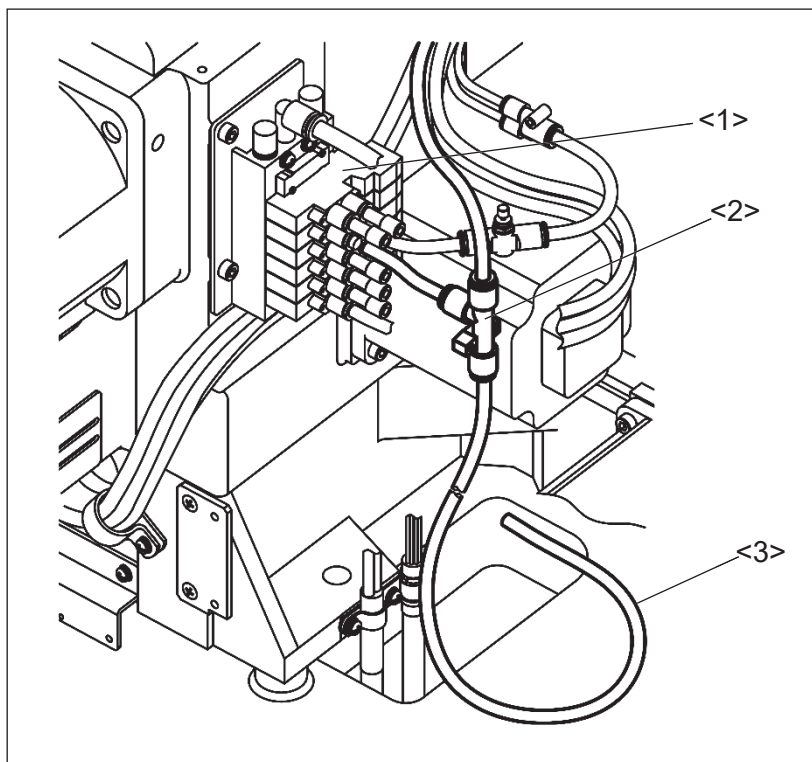

<1>: Magnet valve assembly

<2>: Air ejector

<3>: Oil drainage tube

- (2) While paying attention to the matters described in previous paragraph [3-8. Installation of gas spring].
- (3) Drive the two of staples (No.4) to the table. In this time please check if the oil drainage tube (No.3) is to be arranged as below drawing in advance. To prevent damage to the oil drainage tube (No.3), not to drive the staples (No.4) in state of the oil drainage tube (No.3) is inserted into it. Besides, to prevent the oil drainage tube (No.3) pressed by machine bed, avoid the oil drainage tube (No.3) placed near the damper cushions (No.7).
- (4) Insert the end of the oil drainage tube (No.3) into the hole of the oil pan (No.5) about 50 mm. If the oil drainage tube (No.3) has bended near the oil pan (No.5), cut off the excessive length of the oil drainage tube (No.3).
- NOTICE** When the oil bottle (No.6) filled with waste oil, the outflow pressure from drainage tube will scatter the waste oil to the outside of the oil pan (No.5). Please dispose the waste oil regularly.
- (5) Return the tilted machine to the initial position slowly. In this time check the oil drainage tube (No.3) has no crushing and bending. If it has any abnormal condition like as described, please redo the above piping operation.

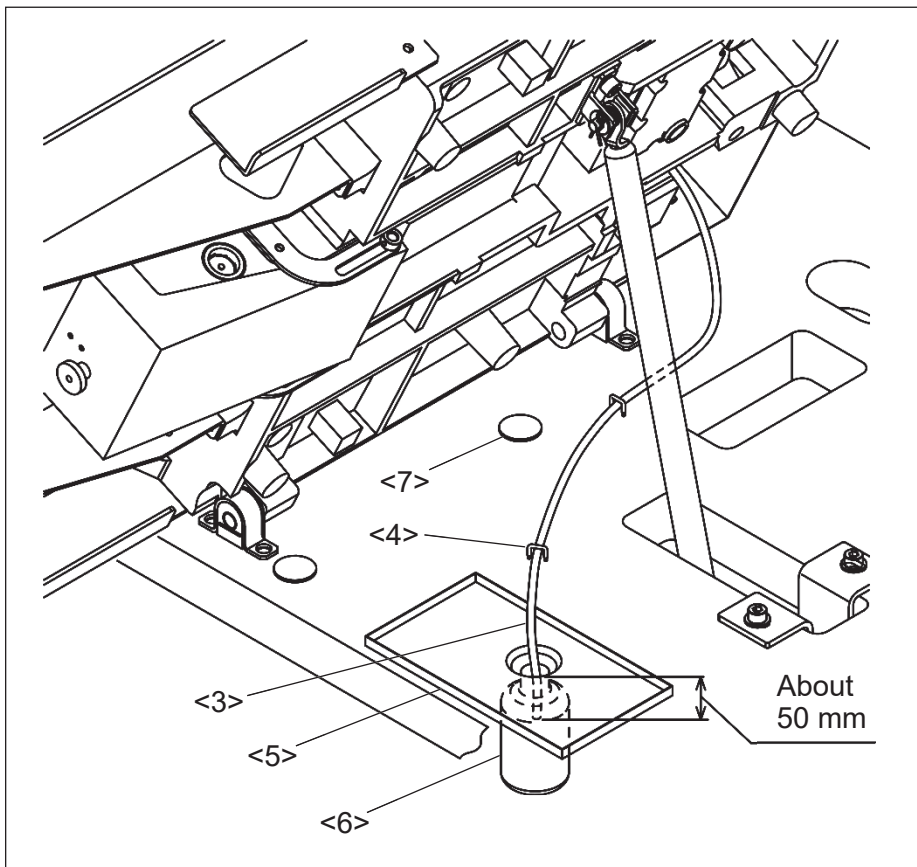

3-12. Installation of the thread stand

- (1) Assemble the parts of the thread stand as shown on the figure.
- (2) Fit the thread stand into the hole at the far right on the machine table with the nut (No.13) and the washer (No.12).

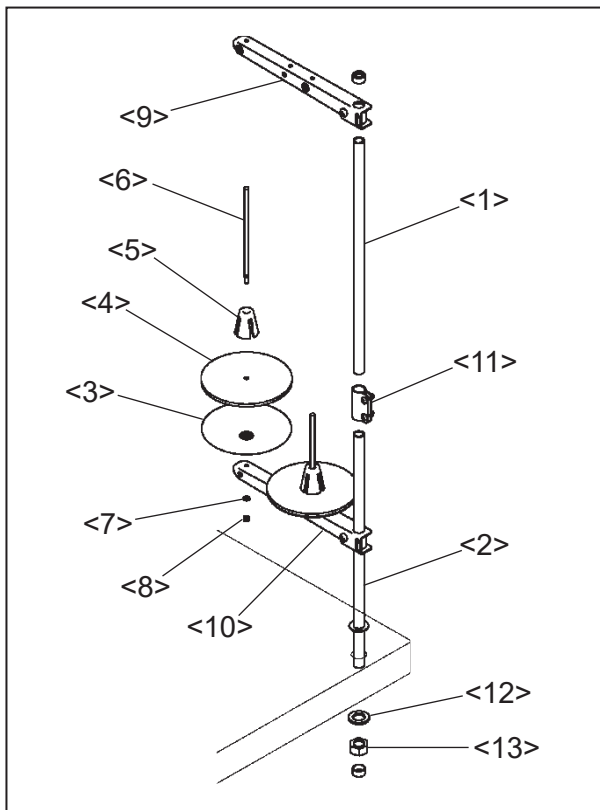

- <1>: Upper column pipe
- <2>: Lower column pipe
- <3>: Spool stand base
- <4>: Spool mat
- <5>: Spool holder
- <6>: Spool shaft
- <7>: Spring washer
- <8>: Nut
- <9>: Thread hunger
- <10>: Spool holder
- <11>: Column joint
- <12>: Washer
- <13>: Nut

3-13. Installation of the eye guard

- (1) Mount the eye guard (No.1) with screw (No.2) to sewing machine head.

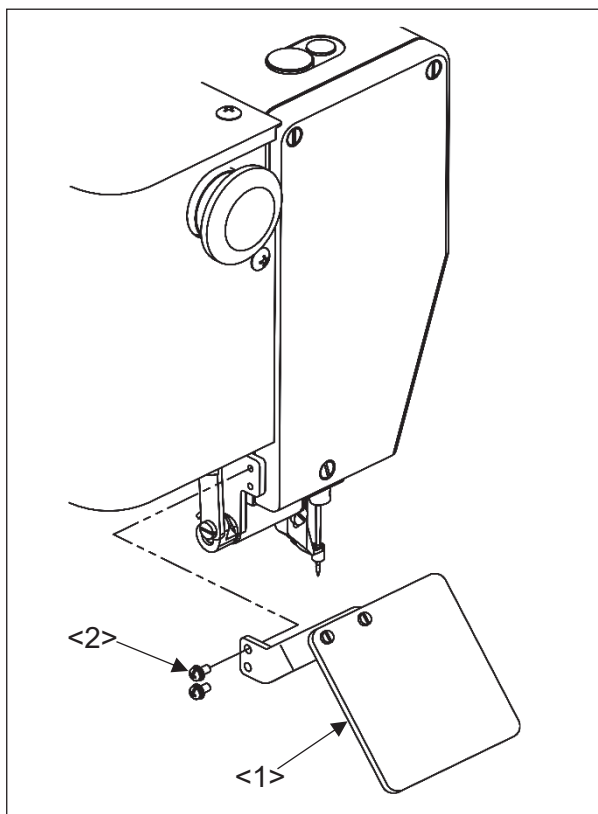

- <1>: Eye guard unit
- <2>: Screw

4. LUBRICATION

4-1. Filling the oil tank

CAUTION

- (1) Please make sure to turn power switch off before lubricating.
- (2) Please pay attention that oil does not get on your skin or in your eyes as it may cause an inflammation.
- (3) Please make sure to keep oil out of the reach of children who may drink oil by mistake.

NOTICE Please make sure to check the amount of oil when operating for the first time after the installation. Also, please lubricate directly to the internal mechanism of machine head such as thread take up lever unit, needle bar and presser bar. The above is the same when the machine has not been used for a long time.

- (1) The oil tanks are set at three places of the machine. Pour oil through the oil holes of (No.1 to No.3) to the oil tanks.
- (2) The oil tank (No.1) and (No.2) have level marks (at the center of the tank). Running out the oil may cause the machine to make abnormal noise and seize up. When the amount of oil decreases to one-third or less than one-third, make sure to fill the tank with oil. Also, do not pour oil more than the level marks. When tilting the machine head, it may cause oil leak.
- (3) The oil tank (No.3) shows the oil amount by the tip of the indicator. The appropriate oil amount is between level marks (high and low red lines).

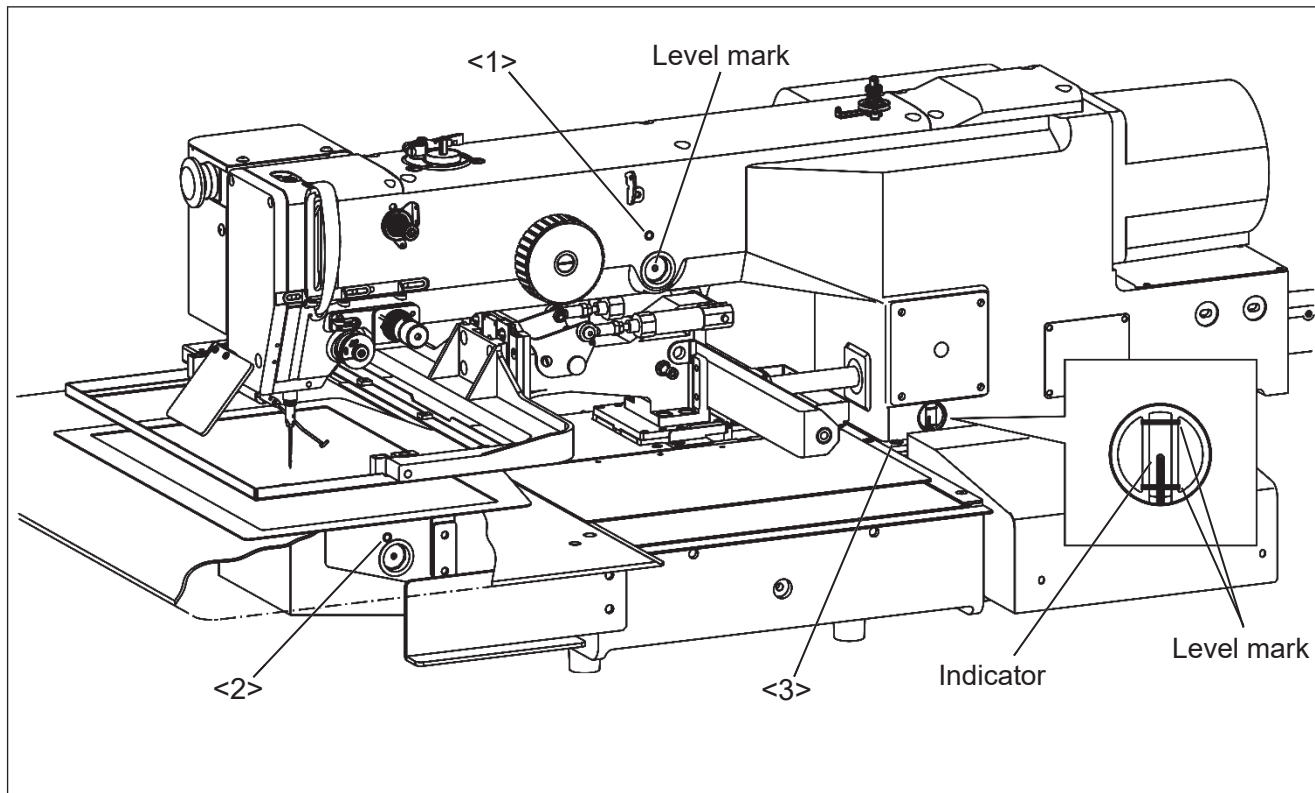

5. PROPER OPERATION

5-1. Setting of the main servo motor upper position.

NOTICE When install the removed main servo motor for adjustment or the like, it is necessary to reset the main servo motor upper position. Please refer to following procedures reset the main servo motor upper position.

(1) Remove the all of any parts, tools and screws on the sliding table. After make sure the work environment safety, Turn the power switch on. At this time, do not press the home position return icon .

(2) Press the  icon from the function mode.

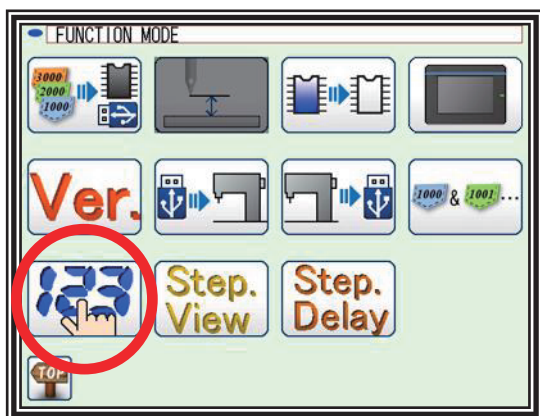

(3) Input the pass word, and press the  icon.

NOTE If press the home position return icon, the  icon is displayed with shading  and cannot display the next setting screen.

(4) Press the main motor up position setting icon.

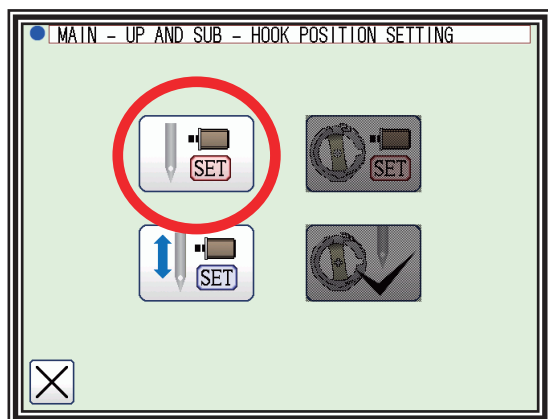

(5) Following the screen indication, set up the main motor up position.

After the completion of setting, press the  icon and then press the  icon.

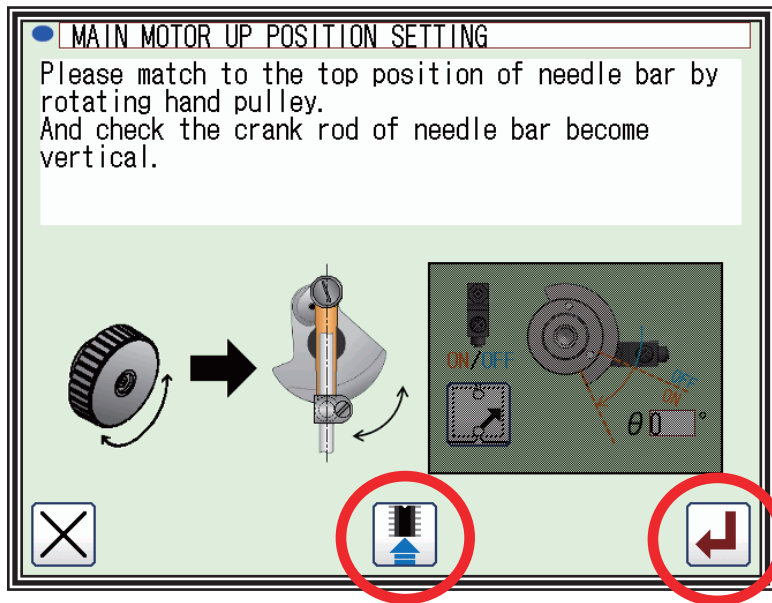

(6) After adjustment turn the power switch off.

5-2. Installation of the needle



(1) Please make sure to turn the power switch off before installing or replacing needles.

(2) Please pay attention for the fingers not to be injured by the needle point.

(1) Loosen the set screw (No.1) then, insert a new needle (No.2) until the needle head is reached the end of the hole of the needle bar (No.3).

(2) Tighten the set screw (No.1) with facing the needle groove (No.4) to the front.

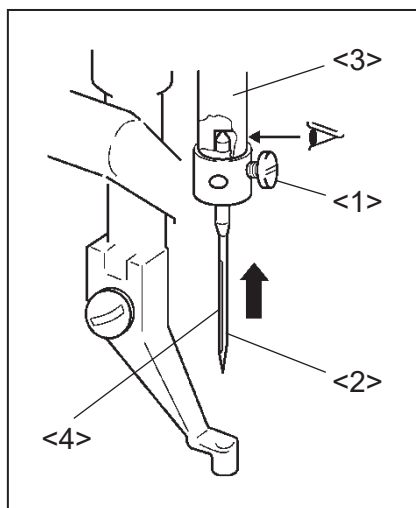

<1>: Set screw

<2>: Needle

<3>: Needle bar

<4>: Needle groove

5-3. Threading the needle thread



(1) Please turn the power switch off when threading a needle.

Thread the needle thread as shown on the figure.

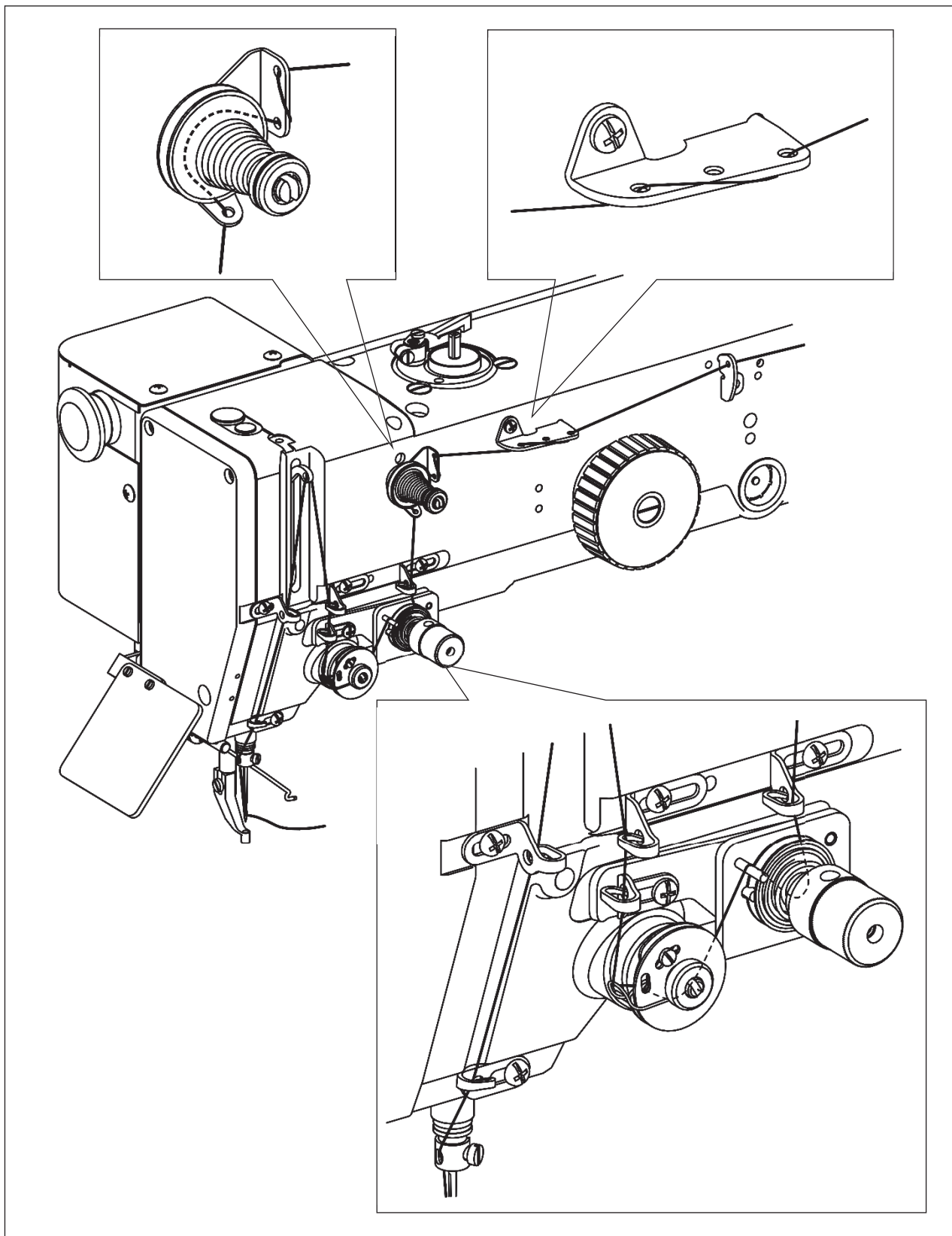

5-4. Winding the bobbin thread



(1) Please do not touch the rotating part during winding thread. Doing so may cause injury and/or the machine failure.

- (1) Route the thread as shown in the below figure then, wind the thread to the bobbin (No.1) in the direction of "a" arrow several times. Then fit the bobbin to the bobbin winder (No.2) and push in the bobbin presser arm (No.3).
- (2) With the machine in the Bobbin Wind Mode, step on the work holder foot switch first and then the start switch second so that the thread continues winding to the bobbin while the start switch is stepped on.
- (3) When the bobbin finishes winding a certain amount (80 to 90 % of the outside diameter of bobbin) of thread, the bobbin presser arm is returned to the initial position. Adjust the amount of the winding thread with the subsidiary arm (No.4).
- (4) To wind the bobbin thread during the sewing operation, carry out the procedure (1) above then, the bobbin winding is performed automatically.

For the bobbin winding mode, refer to the instructions in the paragraph "[3] Explanations of basic screen, icons and operation "7. The Bobbin Winding screen" is explained below" in the **OPERATION PANEL** technical manual.

NOTICE When winding in the bobbin winding screen please make sure to pull out the upper thread from the needle.

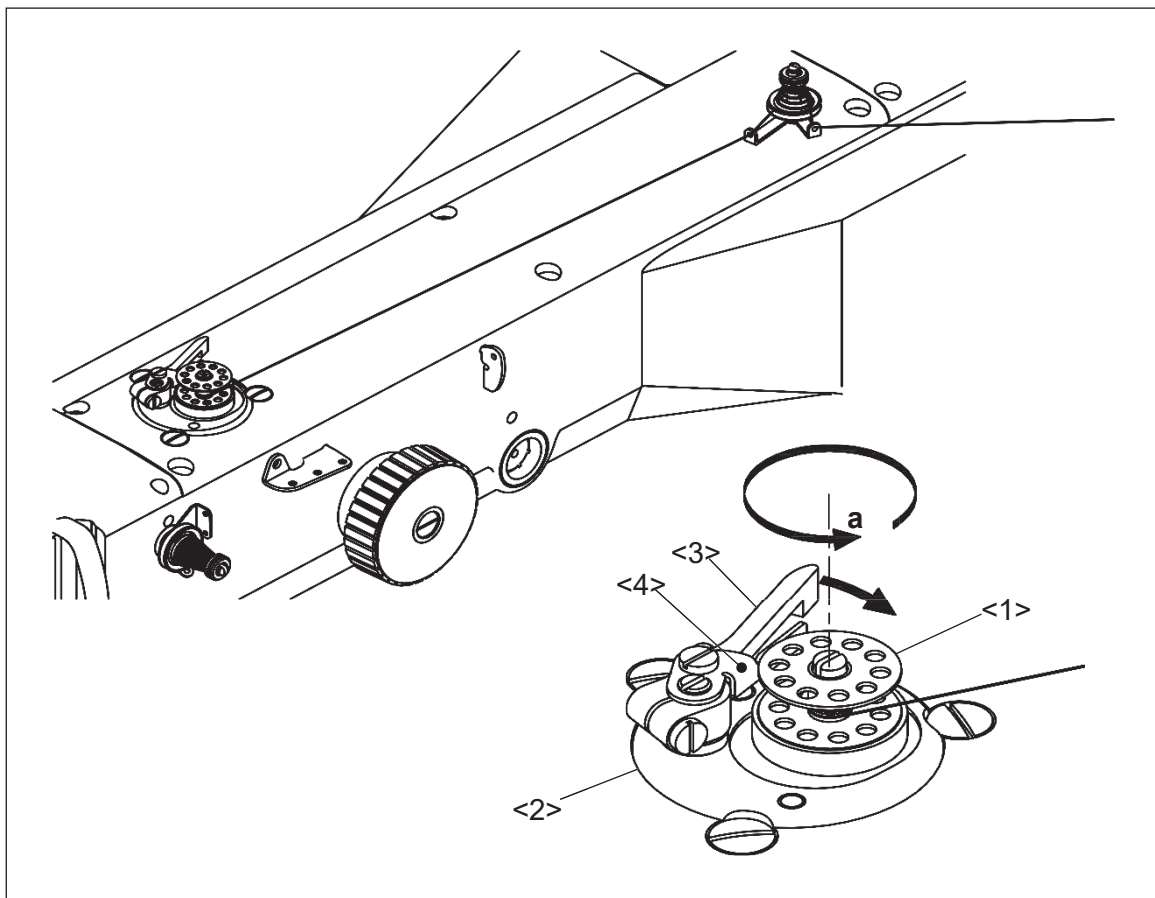

<1>: Bobbin <2>: Bobbin winder <3>: Bobbin presser arm <4>: Subsidiary arm

5-5. Setting the bobbin

(1) Set the bobbin (No.2) into the bobbin case (No.1).

(2) Pull the bobbin thread (No.3) into the slit (No.4) and pass through the thread hole (No.5).

At this time, pull the bobbin thread (No.3) then, check with the bobbin (No.2) if it is rotated to the arrow direction. If it is not, set the bobbin (No.2) into the bobbin case (No.1) over again to get the proper rotation.

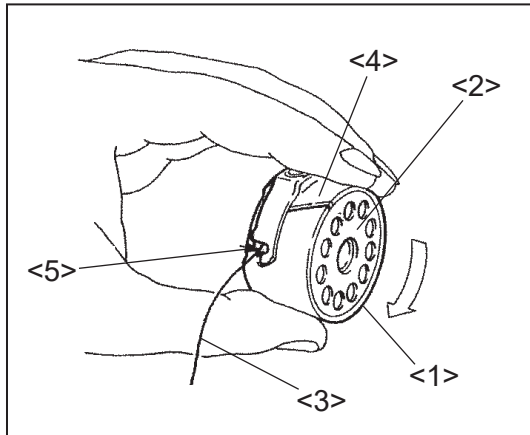

<1>: Bobbin case

<2>: Bobbin

<3>: Thread

<4>: Bobbin case slit

<5>: Bobbin case thread hole

5-6. Setting the bobbin case

(1) Pull the bobbin thread about 50mm out of the thread hole of the bobbin case (No.4).

(2) Open the cylinder cover (No.1).

(3) Open the bobbin case latch (No.2) and hold it then, fit it securely in the shuttle hook (No.3).

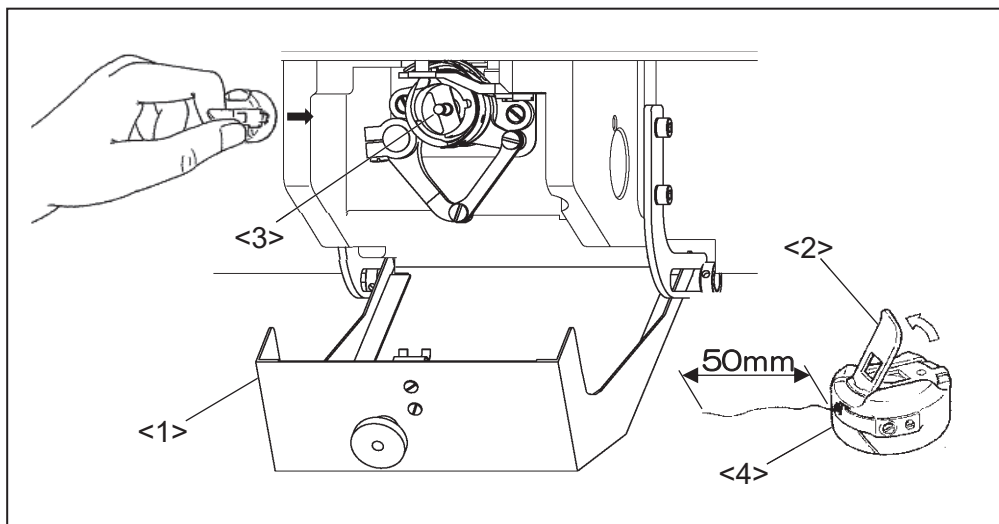

<1>: Cylinder cover <2>: Bobbin case latch <3>: Inner hook

<4>: Bobbin case

5-7. Operation of the halt switch

- (1) If accidents such as a thread breakage, needle breakage and others happened during the sewing, press the halt switch (No.1) immediately. The sewing machine stops instantly.
- (2) To cancel the halt state, press the halt switch again.
- (3) When continuing sewing, step on the grey foot switch to restart at the halted position. (Press the jogging in forward/reverse direction icon so that the sewing start position will move.)
- (4) To cancel sewing, press the home position return icon .

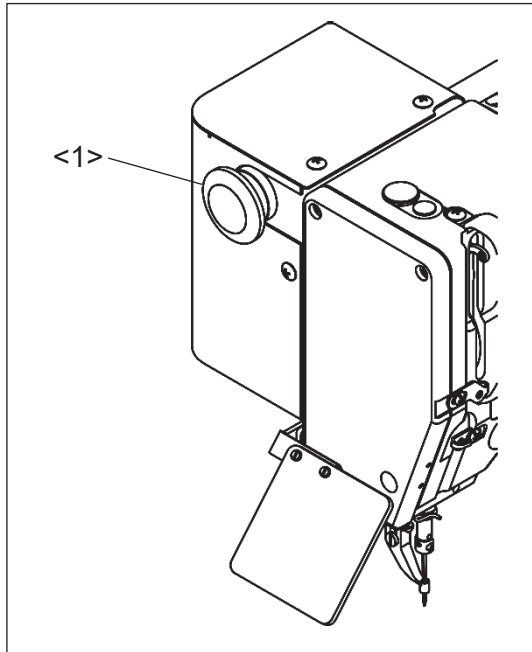

<1>: Halt switch

5-8. Adjustment of the thread tension

- (1) Adjust the bobbin thread tension with the thread tension adjusting screw (No.2) on the bobbin case (No.1). The thread tension become loose if turn the thread tension adjusting screw (No.2) to the counterclockwise, and the thread tension becomes tight if turn it to the clockwise.

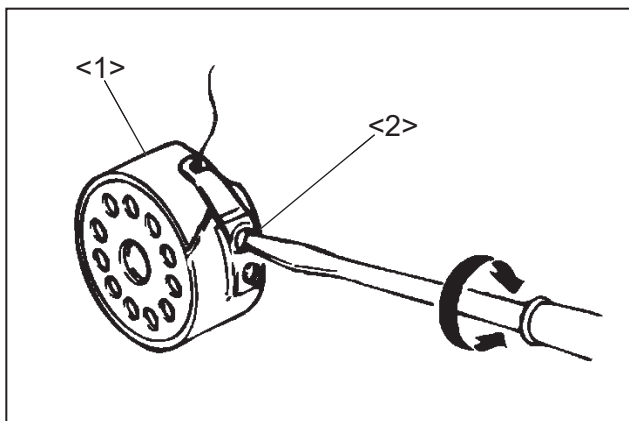

<1>: Bobbin case

<2>: Adjusting screw

5-9. Adjustment of upper thread tension

Adjust the upper thread tension corresponding to the bobbin thread tension. The upper thread tension becomes tight when tightening the thread tension adjusting nut (No.1) clockwise, and the upper thread tension becomes loose when loosening the thread tension adjusting nut counterclockwise.

NOTE It is possible to adjust the upper thread tension automatically. Please refer to the instructions **OPERATION PANEL** technical manual concerning about [Digital tension].

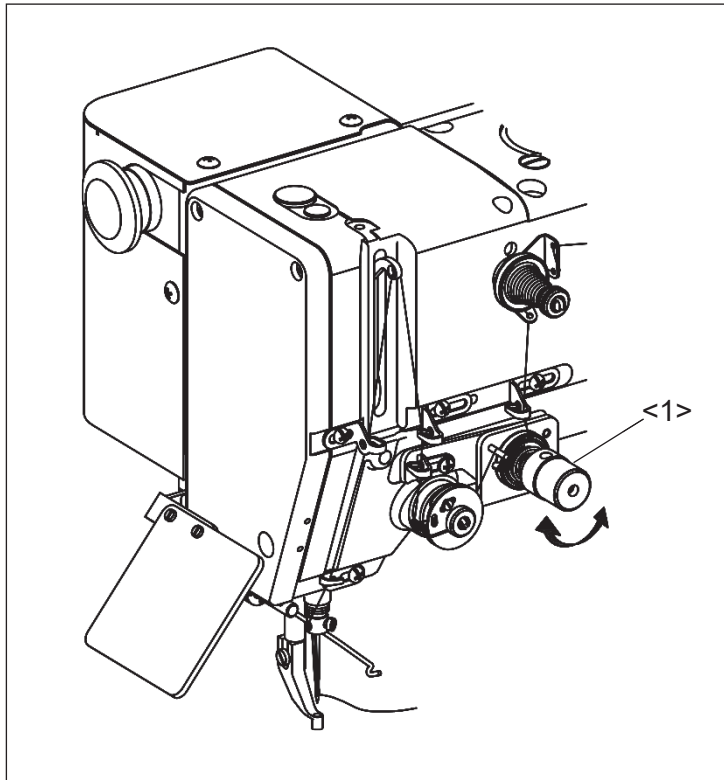

<1>: Thread tension adjusting nut

6. STANDARD ADJUSTMENT



CAUTION

- (1) Please make sure to turn the power switch off before adjusting the sewing machine.
- (2) When adjusting the sewing machine with the power switch on, please be careful not to step on the foot switch by mistake.
- (3) Please be careful not to be injured by a sharp part such as the needle and the hook point.
- (4) Please make sure to put the safety guards (eye guards, link covers, and finger guards or the others) back on the initial position after the sewing machine adjustment.

6-1. Adjustment of the needle bar position

- (1) Turn the power switch off then, stop the needle bar (No.1) at the lowest position.
- (2) Move the needle bar to the position where the needle bar timing mark A is matched to the needle bar bushing (No.2) bottom line. (For the needle class DPx17)
- (3) If the position of the needle bar timing mark A is not matched to the needle bar bushing bottom line, remove the rubber plug (No.3) from the face cover then, loosen the needle bar holder set screw (No.4).
- (4) For the needle class DPx5, move the needle bar to the position where the needle bar timing mark B is matched to the needle bar bushing (No.2) bottom line.

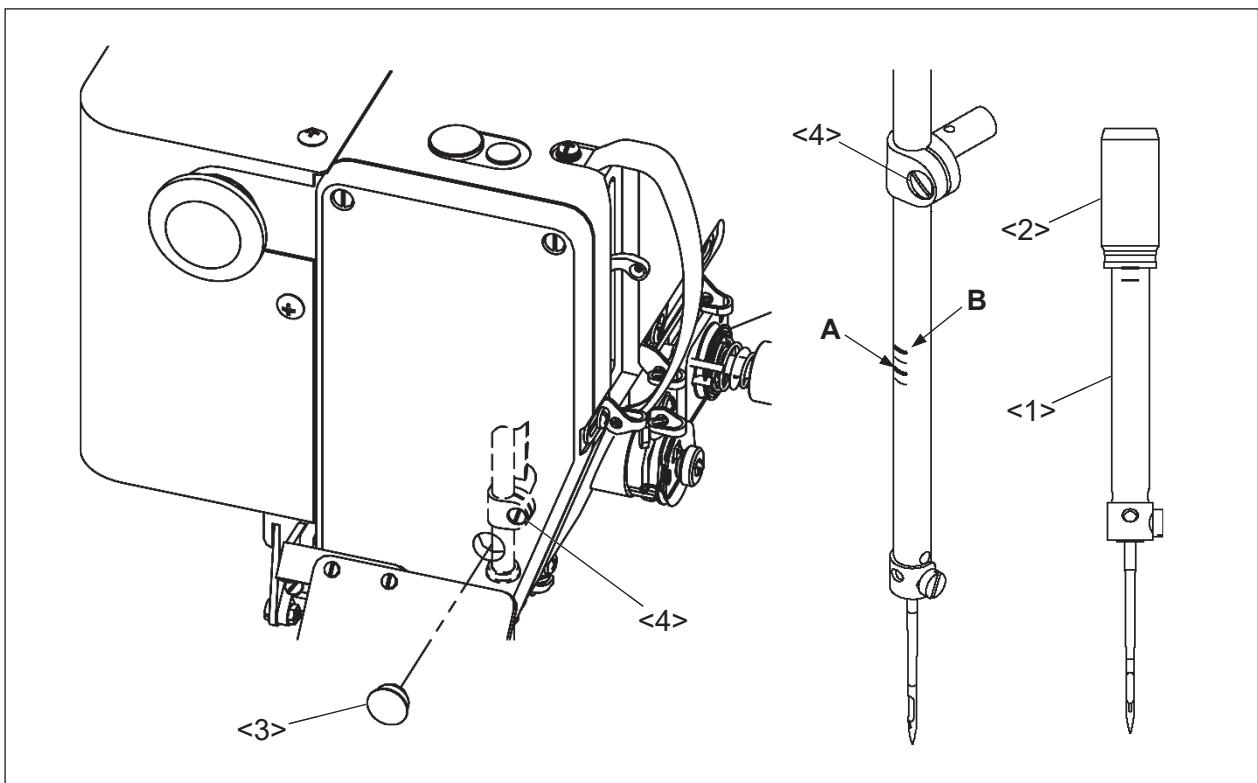

<1>: Needle bar <2>: Needle bar bushing <3>: Rubber plug <4>: Needle bar holder set screw

Timing mark A: For the needle class DPx17

Timing mark B: For the needle class DPx5

6-2 Adjustment of the position between the needle and the rotating hook

- (1) Turn the power switch OFF.
- (2) Open the cylinder cover (No.1).
- (3) Remove the bobbin case (No.2).
- (4) Remove the sliding plate (No.3).
- (5) Loosen the three of hook set screws (No.4).

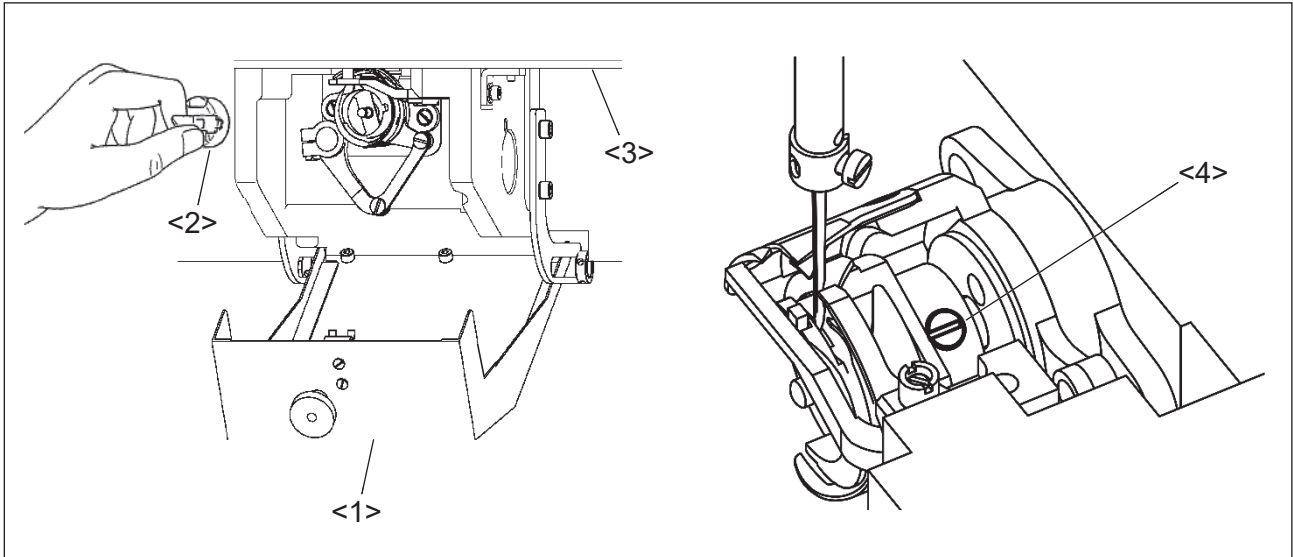

<1>: Cylinder cover <2>: Bobbin case <3>: Sliding plate <4>: Hook set screw

- (6) Turn the sewing machine pulley by hand then, move up the needle bar (No.5) from the lowest position and stop it at the position (No.6) where the needle bar timing mark C is matched to the needle bar bushing bottom line.

NOTE If the needle class is DPX5, match the needle bar timing mark D to the needle bar bushing bottom line.

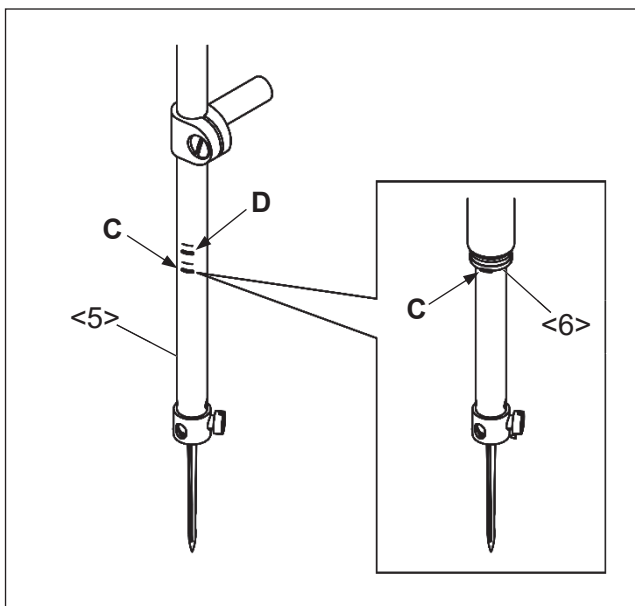

<5>: Needle bar <6>: Needle bar bushing bottom line

Timing mark C: For the needle class DP×17

Timing mark D: For the needle class DP×5

(7) Turn the hook by hand and stop it at the position where the hook point (No.7) meets with the center line of the needle (No.8).

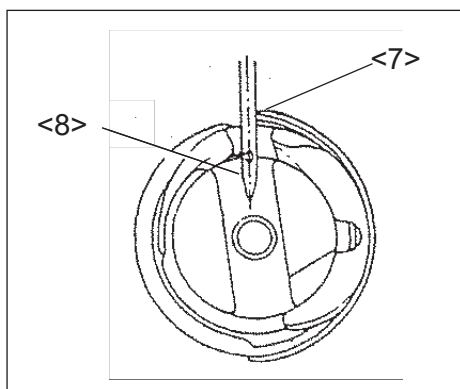

<7>: Hook point
<8>: Needle

(8) Move the hook by hand and adjust the clearance between the hook point and the needle to be about 0.05 mm.

(9) Hold the hook and tighten the three of hook set screws (No.4) securely.

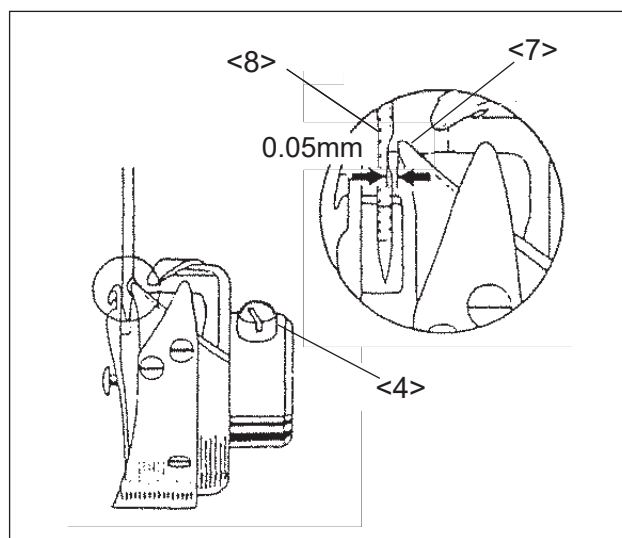

<4>: Hook set screw
<7>: Hook point
<8>: Needle

(10) After the adjustment, put the sliding plate and bobbin case back to the original locations and close the cylinder cover.

(11) When put the sliding plate back on the sewing machine, in order for the needle (No.8) to come into the right center of the needle hole of the needle plate (No.9), make sure that the needle plate hole center matches with the needle point then, tighten the set screws securely.

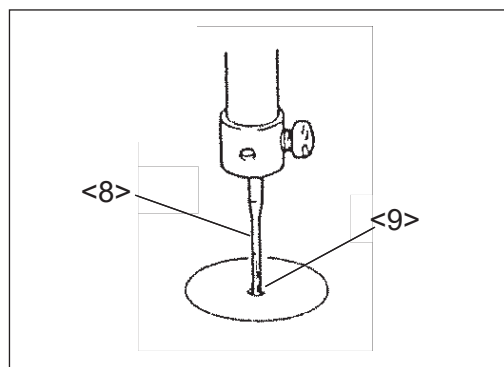

<8>: Needle
<9>: Needle hole

6-3. Adjustment of the hook positioner's position

- (1) Remove the sliding plate.
- (2) Loosen the hook positioner set screw (No.4) and adjust the hook positioner (No.1) position to align the right side of the projection (No.3) with the right side of the needle (No.2) as shown on the figure.
- (3) After the adjustment, securely tighten the hook positioner set screw (No.4) and put the sliding plate back on the sewing machine.

NOTE When put the sliding plate back on the sewing machine, in order for the needle to come into the right center of the needle hole of the needle plate, make sure that the needle plate hole center matches with the needle point. Refer to the previous paragraph [6-2(11)].

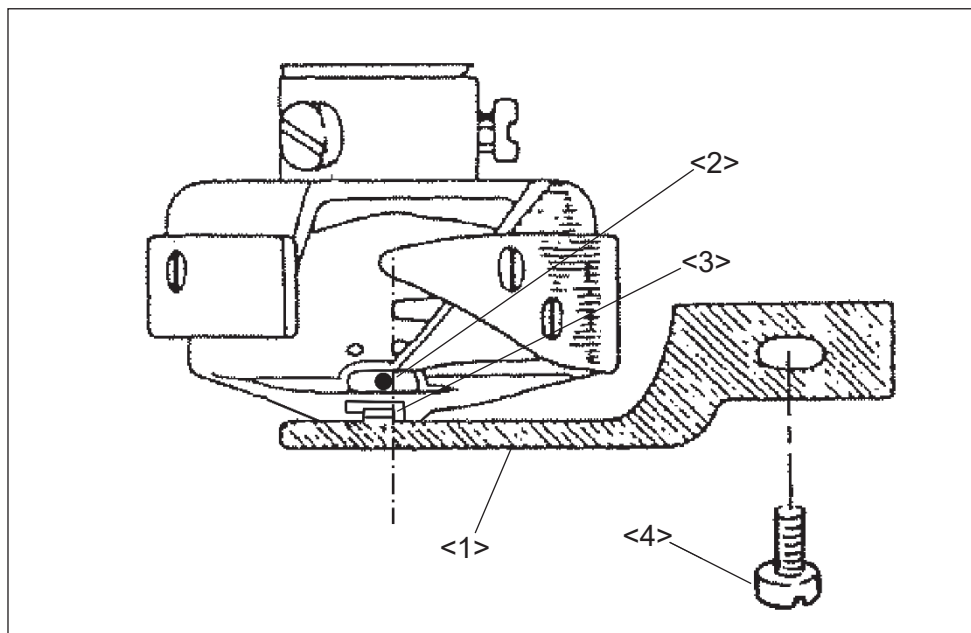

<1>: Hook positioner <2>: Needle <3>: Right side of hook positioner
<4>: Hook positioner set screw

6-4 Adjustment of the oil lubrication for the rotating hook

(1) Open the cylinder cover (No.1).

(2) Tighten the oil flow adjusting screw (No.2) lightly by fingers or a screw driver until it is stopped the turn.

NOTE Do not tight the oil flow adjusting screw (No.2) too much.

(3) Adjust the oil flow in the range of one reverse turn from the deadlock position of the oil flow adjusting screw (No.2). The oil flow is decreased if loose the oil flow adjusting screw (No.2).

(4) It can be checked the oil flow with the situation that the oil splashes on the paper covered over the running rotating hook.

(5) After the adjustment, close the cylinder cover (No.1).

NOTICE The oil flow is adjusted for the sewing speed at 2,300rpm as the factory default setting. When using other speeds, adjust the oil flow each time.

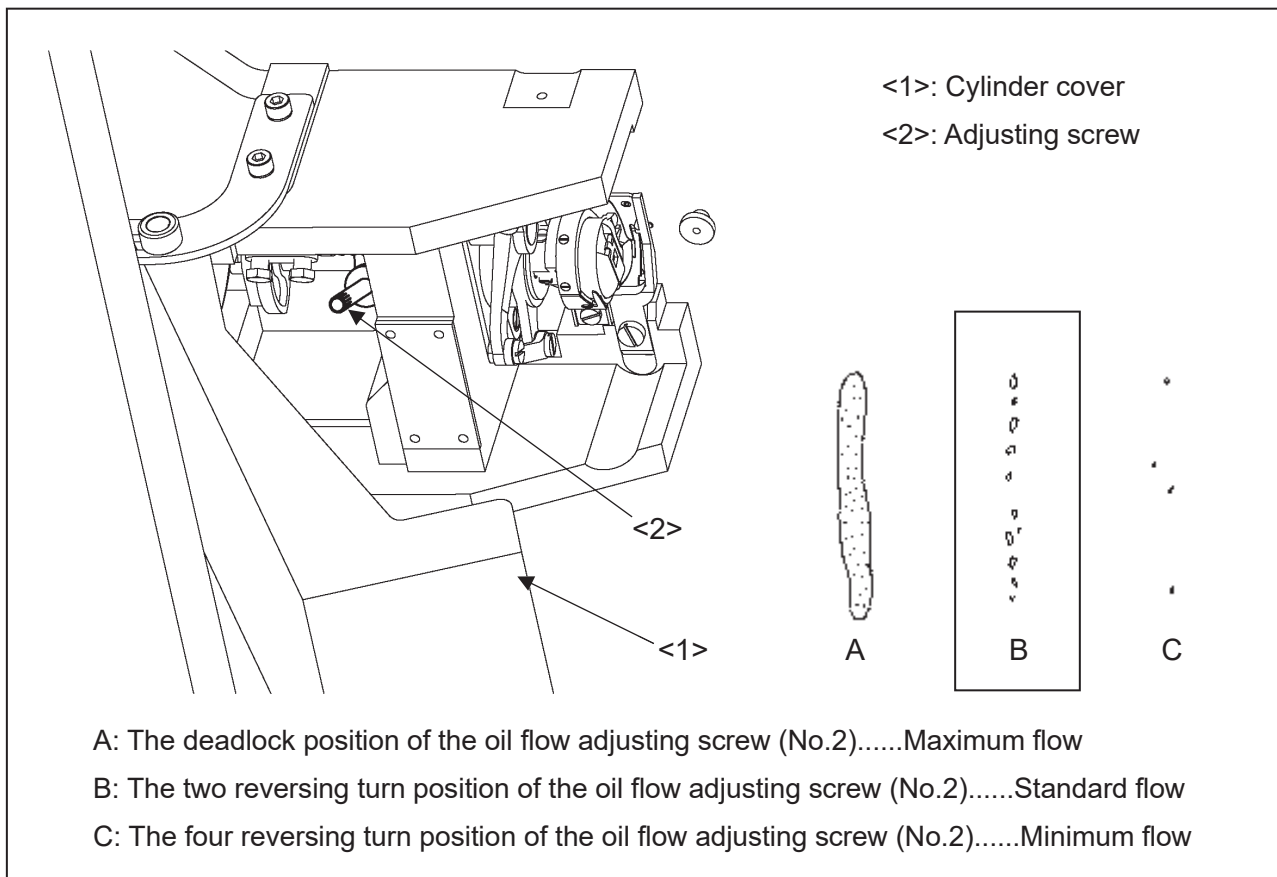

6-5. Adjustment of the oil lubrication for the machine head

(1) Amount of oil supply for the machine head is controlled by specified injection time for every specified stitch number. The lubrication oil is injected by compressed air.

Press the  on the standard screen, and press the **Program** icon.

Select the **OIL LUBRICATION** icon and enter the setting mode.

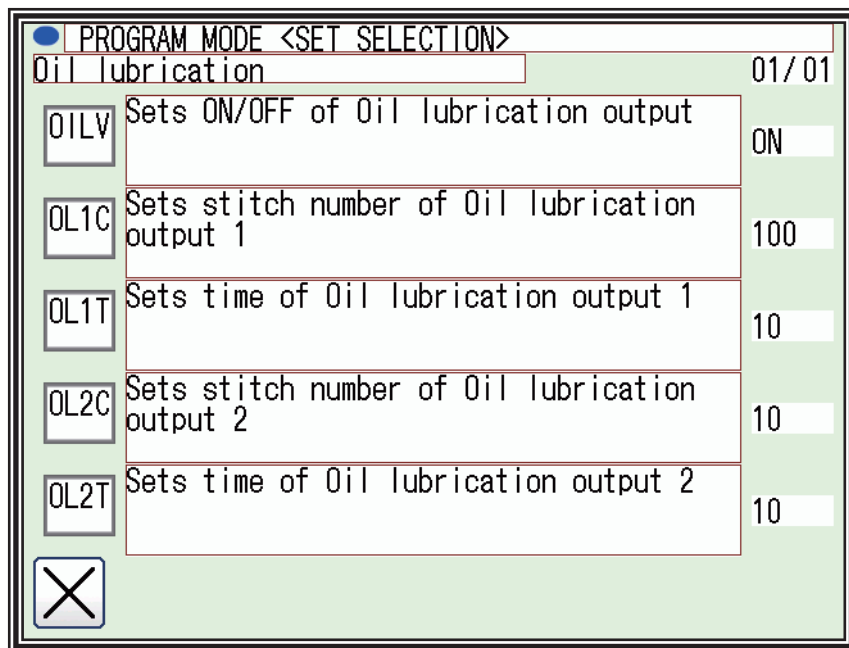

OL1C: Setting of the machine head oil injection timing for every stitch number.

OL1T: Setting of the machine head oil injection time.

OL2C: No use

OL2T: No use

Default oil injection setting is described below.

Machine head: one second for every ten thousand stitches.

NOTE1 Please adjust the oiling amount for each sewing condition. For example, increase the (OL1C) value or shorten the oil injection time (OL1T) when much oil is consumed. However it is necessary to note the machine seizing when limit the oiling amount.

NOTE2 When shorten the oil injection time (OL1T), set the value to 3-5 as a guide.

(2) It is also possible to lubricate once at the sewing start, instead of setting the oil injection timing for every stitch number (OL1C). Please change the set value as following.

Press the  on the standard screen, and press the **Program** icon.

Select the **OIL LUBRICATION** > **OILV** > ST [Valid the oil lubrication output at start of sewing] in order. However, oil consume may increase when use this function. In this case, shorten the oil injection time (OL1T).

6-6. Setting of the presser foot movement

It is not necessary to adjust the presser foot movement with operating the mechanical unit. Please refer to the instructions **OPERATION PANEL** technical manual and change each setting in matching with the sewing conditions.

(1) Adjustment of the presser foot height position:

Please refer to [9] Controlling the Presser Foot.

(2) Adjustment of the presser foot timing and stroke:

Please refer to [18] [Easy setting] 1-(3) [PF motion setting].

(3) Adjustment of the presser foot lift:

Please refer to [18] [Easy setting] 3-(2) [PF rising position adjustment].

6-7. Adjustment of the wiper

(1) Shut off the air supply and loosen the wiper set screw (No.3) and adjust the wiper (No.1) to be positioned where the wiper (No.1) passes under the needle (No.2) point with a clearance of about 2mm right after the sewing machine stops at the take up lever upper position.

(2) When setting the presser foot (No.4) to upper position during the sewing of thick material, the setting may not leave the clearance of passing wiper. The wiper cannot be used in this case.

(3) The wiper does not work enough, loosen the wiper adjust screw (No.5) and adjust the wiper position.

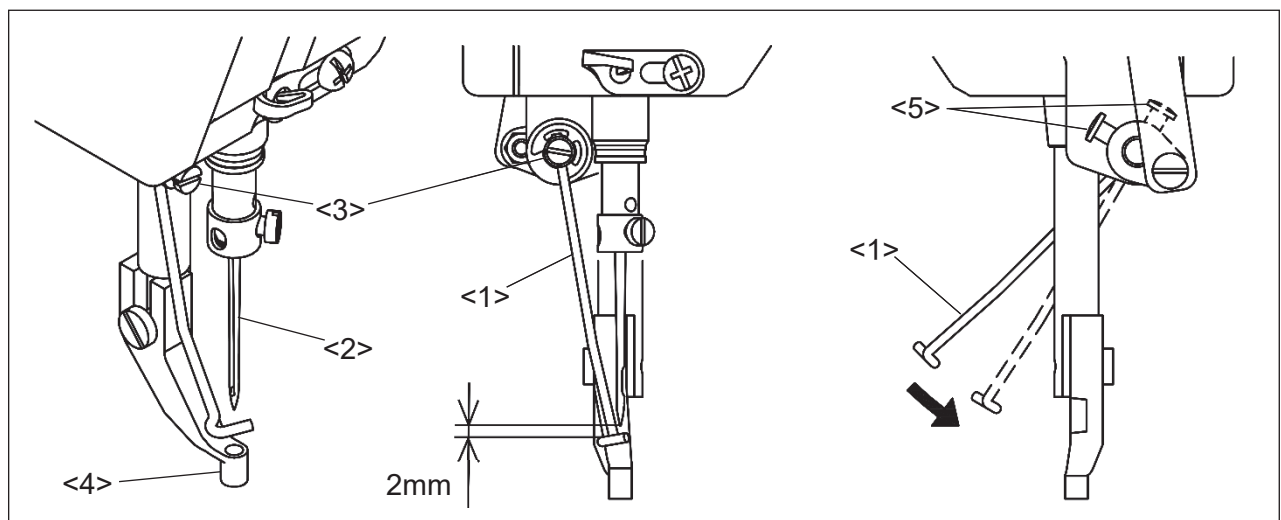



<1>: Wiper <2>: Needle <3>: Wiper set screw <4>: Presser foot <5>: Wiper adjust screw

(4) When the wiper function is not be used (not able to be used), set the following.

Set the wiper function to off.

Press the  on the standard screen to open the MENU mode.

(5) Press the  >  >  [Wiper ON/OFF] in order.

(6) Select the  on the [Wiper ON/OFF] screen, and press the .

6-8. Adjustment of the thread take up spring

6-8-1. Adjusting movable range of the thread take up spring

(1) To adjust the thread take up spring (No.1), loosen the stopper stop screw (No.2) and move the stopper (No.3). When moved the stopper (No.3) in the arrow direction, movable range of the thread take up spring (No.1) is increased.

(2) After adjustment tighten the stopper stop screw (No.2).

[NOTE] Standard stopper (No.3) position is showing in following figure. The take up spring (No.1) position is set to be the almost same height of the center line <A> of the thread take up spring unit (No.4).

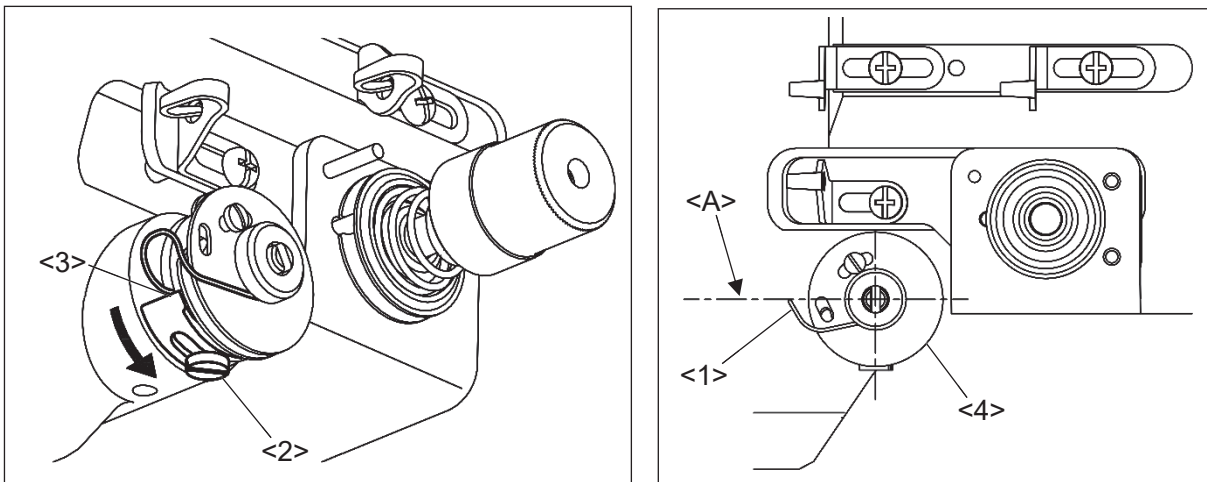

<1>: Thread take up spring <2>: Stopper stop screw <3>: Stopper <4>: Thread take up spring unit

6-8-2. Adjusting intensity of the thread take up spring

(1) Loosen the lock nut (No.1) and turn the adjusting shaft (No.2) with screw driver. When the adjusting shaft (No.2) won't screw well, loosen the set screw (No.3) slightly. When tightening the screw driver clockwise, the thread take up spring tension becomes loose, and when loosening the screw driver counterclockwise, the thread take up spring tension becomes tight.

(2) After adjustment, tighten the lock nut (No.1).

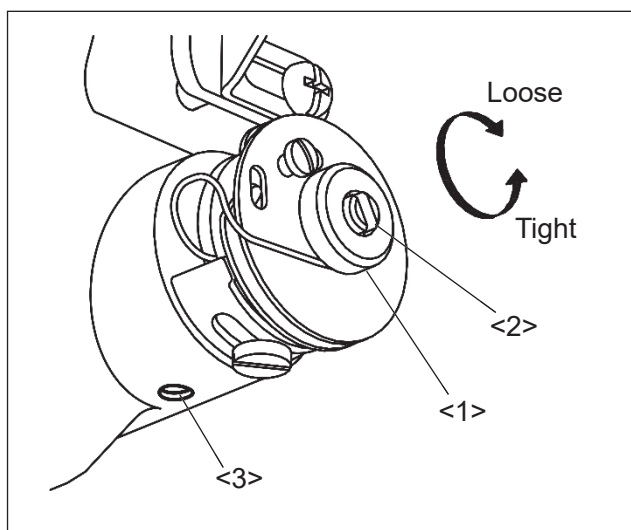

<1>: Lock nut
<2>: Adjusting shaft
<3>: Set screw

6-9. Adjustment of the thread tail after the trimming

- (1) Adjust the thread tail with the pre-tension (No.1).
- (2) When turning the nut (No.2) clockwise, the thread tail becomes shorter. When turning the nut (No.2) counterclockwise, the thread tail becomes longer.

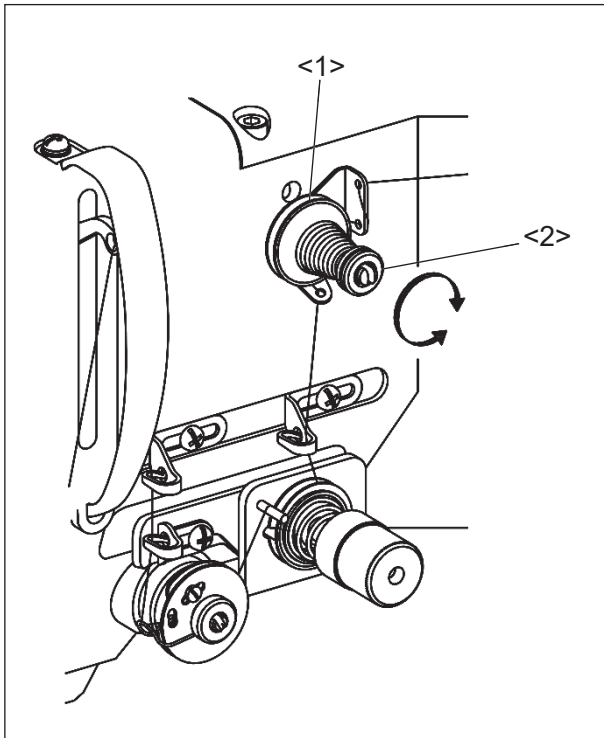

<1>: Pre-tension
<2>: Nut

6-10. Adjustment of the air pressure



★ If the secondary side air pressure is set too high, trouble such as operation faults may occur. Always set the pressure to within 0.4MPa.

- (1) Air pressure is provided from an air source. Lift and turn the air regulator's adjustment knob (No.1) located under the table to adjust the air pressure.
- (2) If turn the adjusting knob (No.1) to the clockwise, the air pressure is increased.
- (3) If turn the adjusting knob (No.1) to counter clockwise, the air pressure is decreased.
- (4) 0.4MPa (4kgf/cm²) is the standard air pressure as a normal sewing operation.

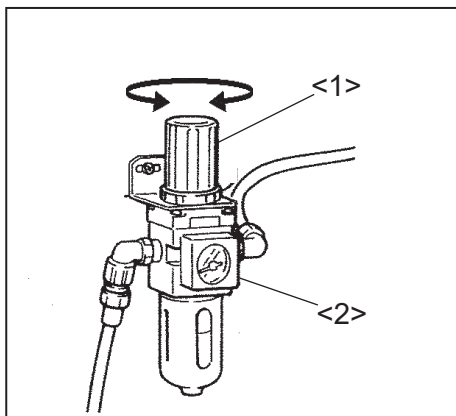

<1>: Adjusting knob
<2>: Air regulator

6-11 Changing the work holder

- (1) Remove the work holder (No.1) by pressing it down from the engaged area with the pin (No.2) of the clamp adapter.
- (2) Prepare another work holder and securely engaged its U shaped mortise (No.3) with the pin (No.2) of the clamp adapter.

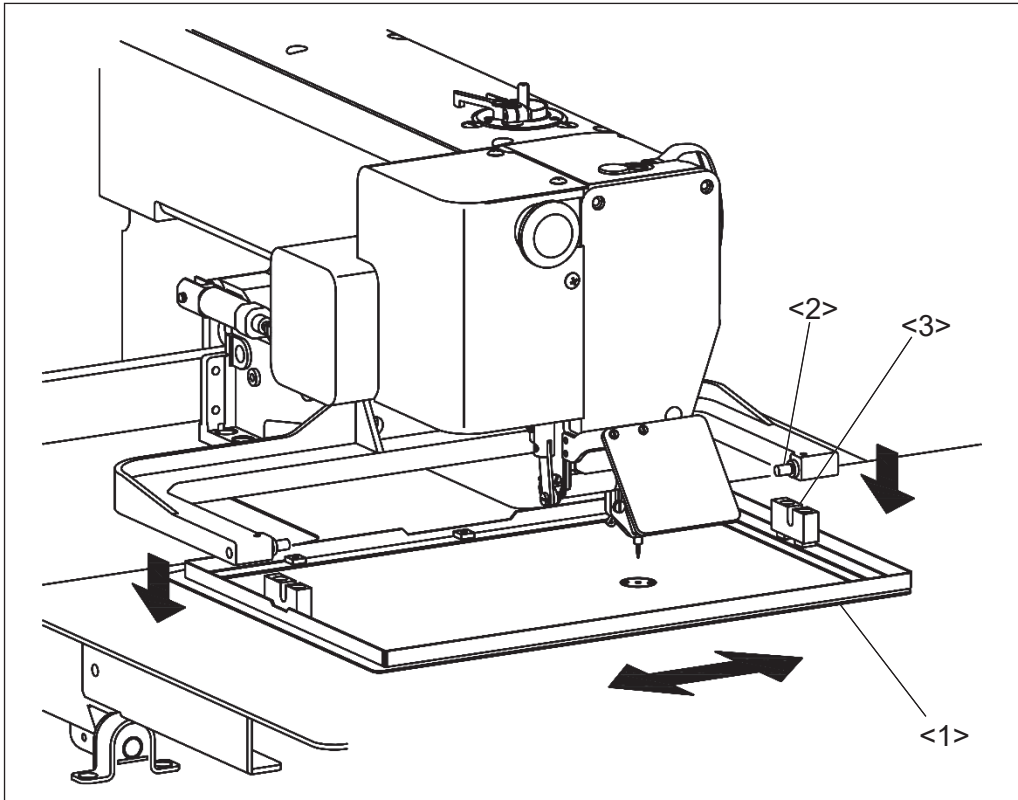

<1>: Work holder <2>: Pin <3>: U shaped mortise

7. VARIOS ADJUSTMENT



CAUTION

- (1) Please make sure to turn the power switch off before adjusting the sewing machine.
- (2) When adjusting the sewing machine with the power switch on, please be careful not to step on the foot switch by mistake.
- (3) Please be careful not to be injured by a sharp part such as the needle and the hook point.
- (4) Please make sure to put the safety guards (eye guards, link covers, and finger guards or the others) back on the initial position after the sewing machine adjustment.

7-1. How to exchanging the tension spring of the needle thread tensioner unit

According to following procedures, exchange the tension spring (No.1). It is same way to exchanging the optional stronger tension spring.

NOTICE It is required to use the factory original tension spring.

- (1) Turn the thumb screw (No.2) and decrease the tension spring pressure.
- (2) Loosen the set screw (No.4) and then remove the set screw (No.3) and remove the thumb screw (No.2).

The set screw (No.3) and (No.4) are same parts.

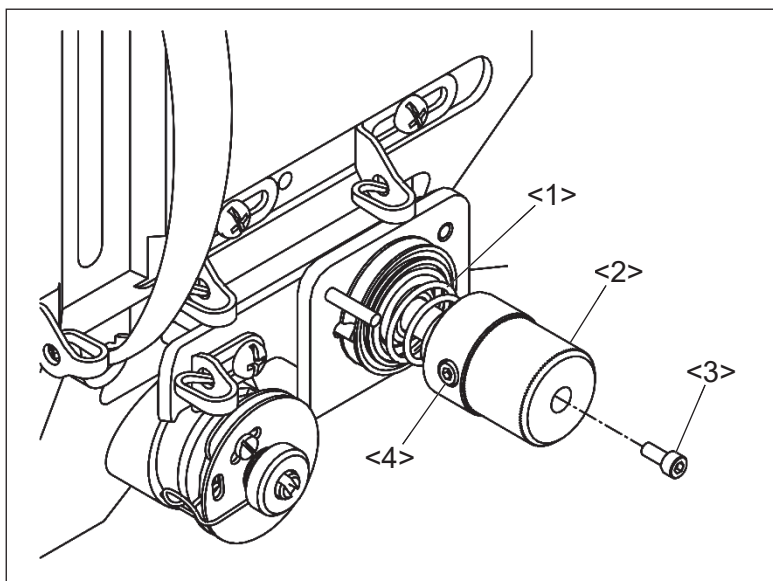

<1>: Tension spring

<2>: Thumb screw

<3>: Set screw

<4>: Set screw

(3) Pull out the thumb screw (No.2) from tensioner shaft (No.5). In this time the bearing (No.6) is removed too.

(4) Remove the tension spring (No.1).

(5) After exchanging the tension spring (No.1) back the bearing (No.6) and thumb screw (No.2) in order.

Then tighten the set screw (No.4) and screw (No.3) in order.

NOTE 1 Bearing (No.6) is consist of three parts. Please taking care not to make misassembling by referring following figure.

NOTE 2 Locate the groove of the tension disc (No.9) to the thread release pin (No.12) when removed tension disc (No.9), (No.10) and tension disc holder (No.11).

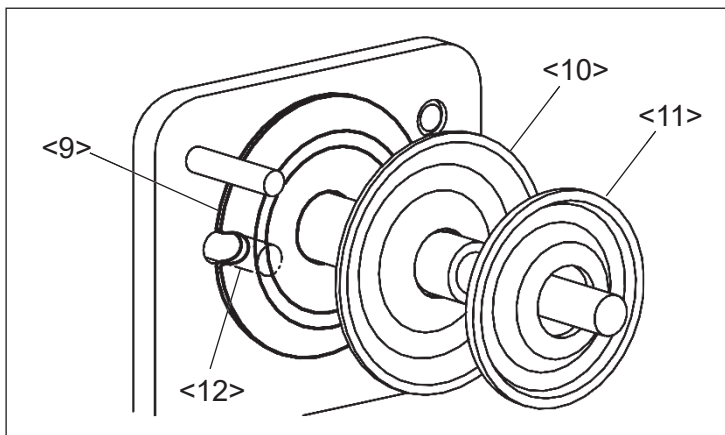
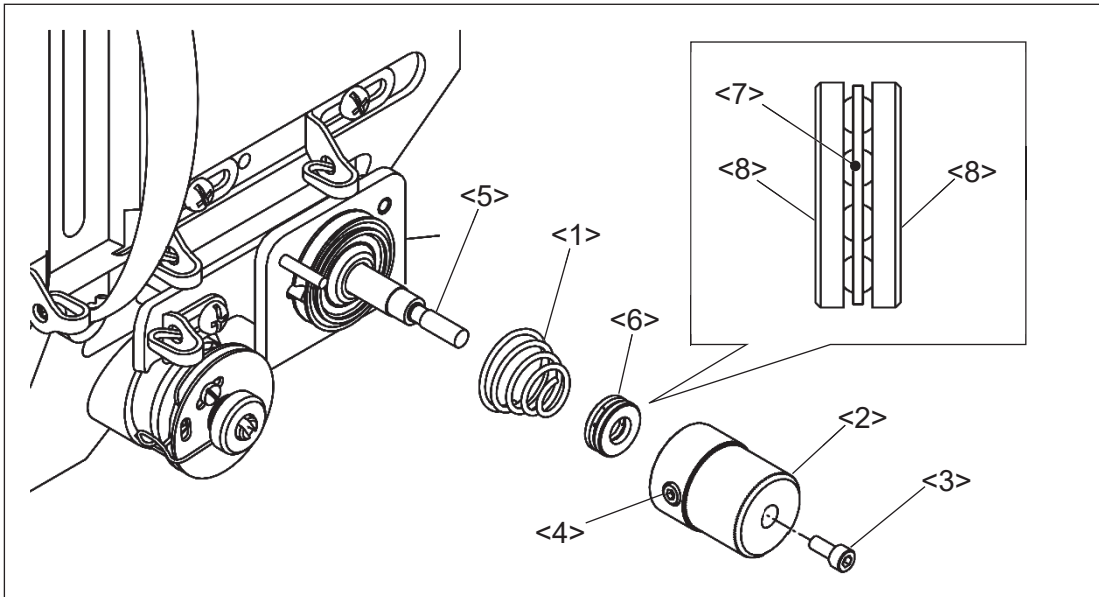

- <1>: Tension spring <2>: Thumb screw <3>: Set screw <4>: Set screw
<5>: Tensioner shaft <6>: Bearing <7>: bearing holder <8>: Washer
<9>: Tension disc <10>: Tension disc <11>: Tension disc holder
<12>: Thread release pin

7-2. Adjustment of the detector position of the presser foot unit

According to following procedures, adjust the detector position in case of parts replacement etc.

NOTE The presser foot lifting position is setting by 18 mm from top of the sliding plate.

NOTICE The presser foot movement is based on the origin detection position. To prevent the sewing trouble and parts breaking, adjust the detector position exactly.

- (1) Remove the eye guard (No.1) by referencing the previous paragraph [3-13. Installation of the eye guard]
- (2) Remove the three of fixing screws (No.2) and remove the face cover (No.3).
- (3) Remove the needle (No.4).

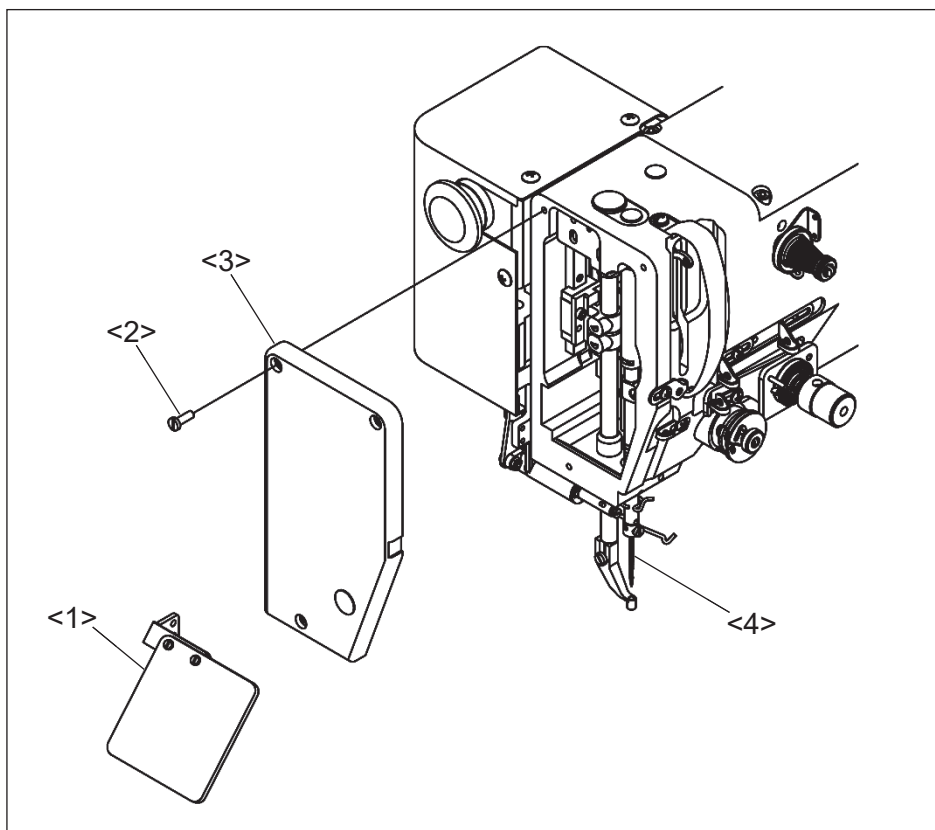

<1>: Eye guard <2>: Fixing screw <3>: Face cover <4>: Needle



(4) Detector (No.4) is installed in machine head. Detector (No.4) detects end of the presser bar (No.5).

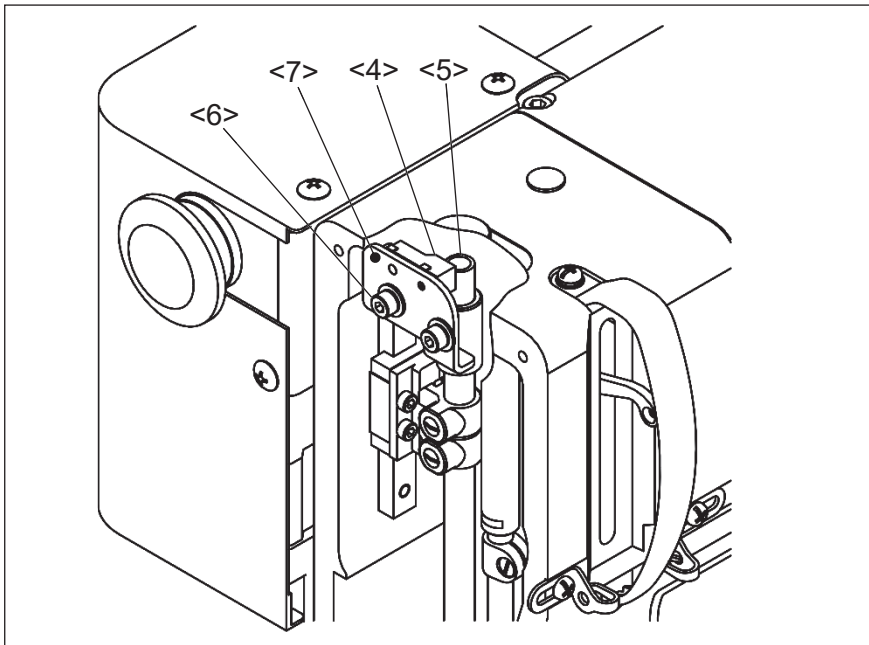

Before adjustment, it is necessary to make sure following items.

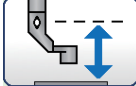

- <4>: Detector
- <5>: End of presser bar
- <6>: Fixing screw
- <7>: Detector bracket

(a) Press the  from standard screen and check if the presser foot height value (ZTHK) is [***].
(No setting) If different, please change to the initial set value.

(b) Press the  >  >  >  from standard screen and check if the presser foot lifting value is [18.0 mm]. If different, please change to the initial set value [18.0 mm].

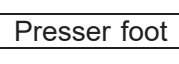
(c) Press the  >  >  > ZNPP [Distance from PF sensor edge to the top surface of slide plate]. Check if the value is [240] (24.0 mm). If different, please change to the initial set value [240].

(d) For prevent the detection error, please use the factory default presser foot.

(e) For prevent the detection error and miss positioning of presser foot height, please check if the presser foot installed fully to the presser bar's mounting face.

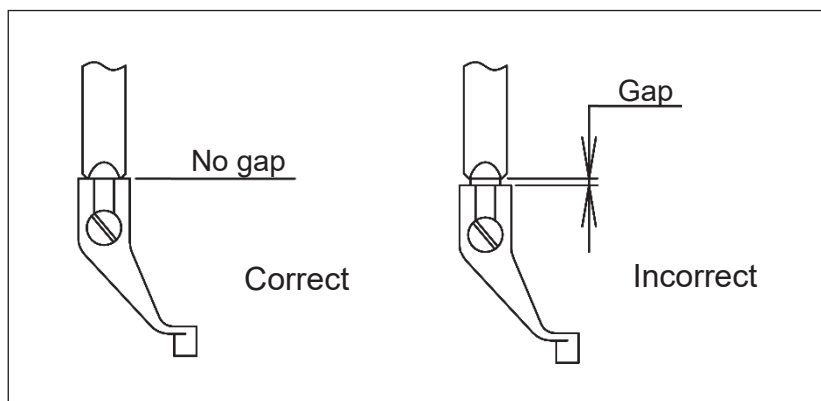

- (5) Loosen the fixing screw (No.6) and move the detector bracket (No.7) upward in advance then tighten the fixing screw (No.6) temporarily.
- (6) Remove the sewing material and work holder and any parts. After make sure the work environment safety, turn the power switch on.
- (7) After finish the origin movement, make sure the clearance between the bottom of presser foot and top of the sliding plate is 18 mm. If this clearance is more, loosen the fixing screw (No.6) and move downward the detector bracket (No.7) and tighten the screw again and press the origin return icon.

NOTICE Please be careful not to step on the foot switch by mistake.

- (8) Continue the above adjustment up to be a correct distance 18 mm.

NOTICE From the second home position returning, it does not use the home position return sensor. Make sure to turn the power switch off to change the mechanical home position.

To use the sensor from the second returning, press **Program** > **home position** > **SHP**

[Home returning method since the second time returning] on the standard screen and set it ON.

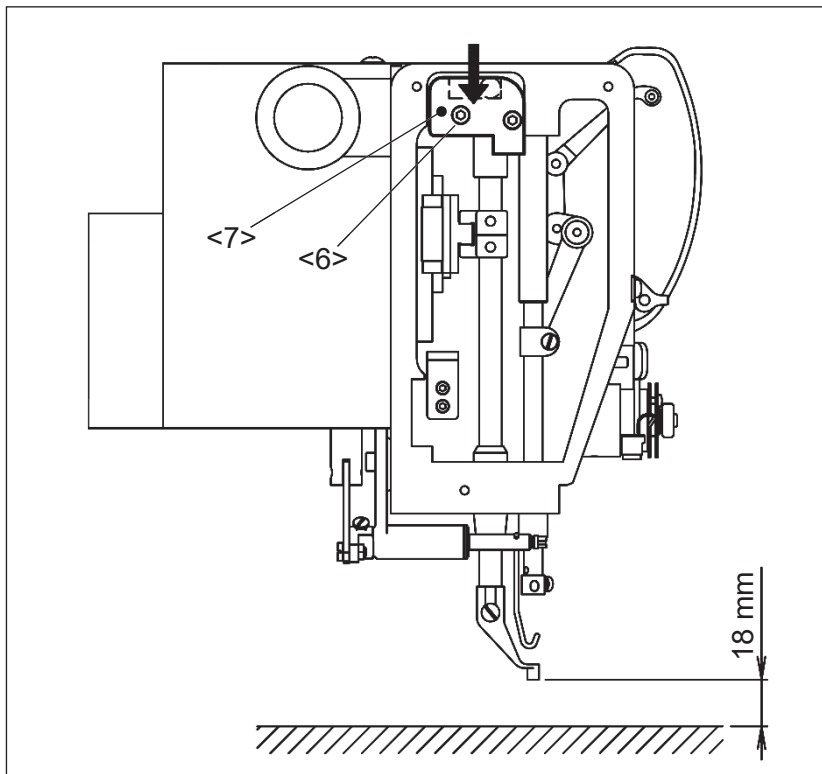

<6>: Fixing screw
<7>: Detector bracket

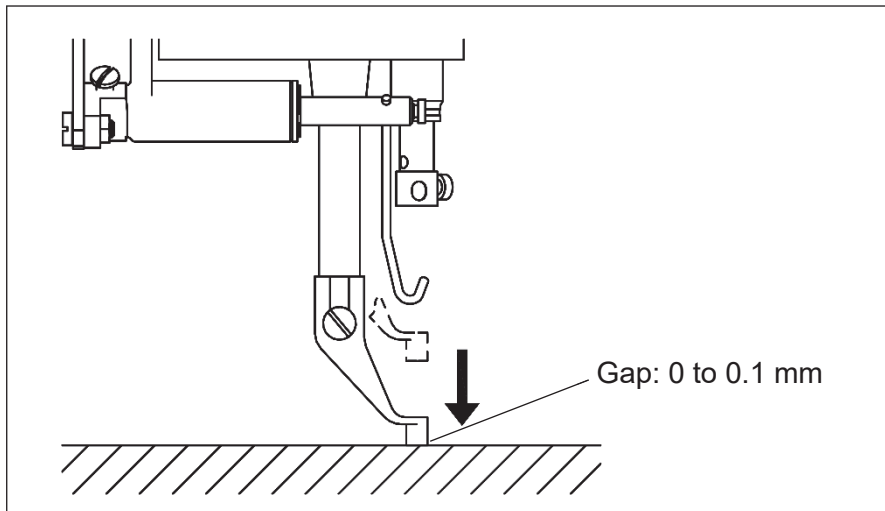

(9) Press the presser foot down icon and check the gap between bottom of presser foot and top of sliding plate is 0 to 0.1 mm. If there is any collision sounds when down the presser foot, please readjust above. If the gap more than 0.1 mm, please readjust too.

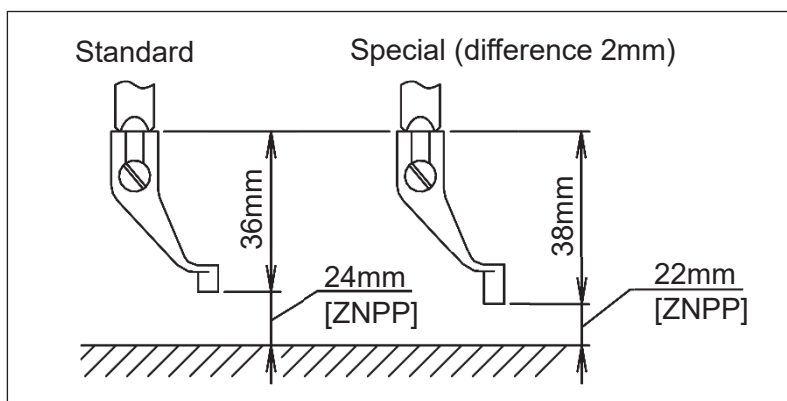

7-3. How to replace with a special presser foot

When replace the standard presser foot only at needed, it is necessary to change the ZNPP [Distance from PF sensor edge to the top surface of needle plate] from default value. For example, to using a special presser foot which length is 2 mm longer, change the value to [220] (22.0 mm) from default value [240] (24.0 mm) as showing in the following figure. According to the following procedures change the ZNPP value.



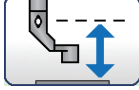

(1) Press the  >  >  >  [PF position adjustment] from standard screen.

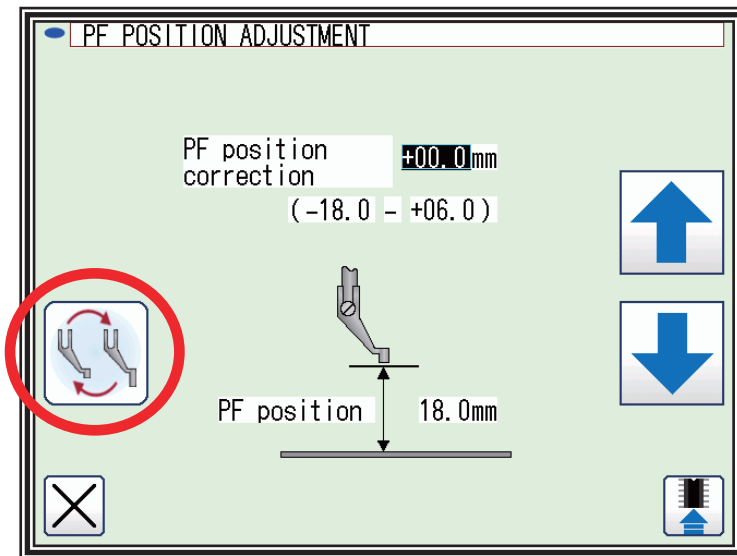
(2) Press the  icon from the [PF position adjustment] screen.





(3) Replace the presser foot with standard one.

(4) Press the   icon and down the presser foot to the top of the needle plate. In this time, set the gap between bottom of presser foot and top of needle plate to be 0 to 0.1mm. The screen indicates ZNPP default value (Upper) and current value (Lower).

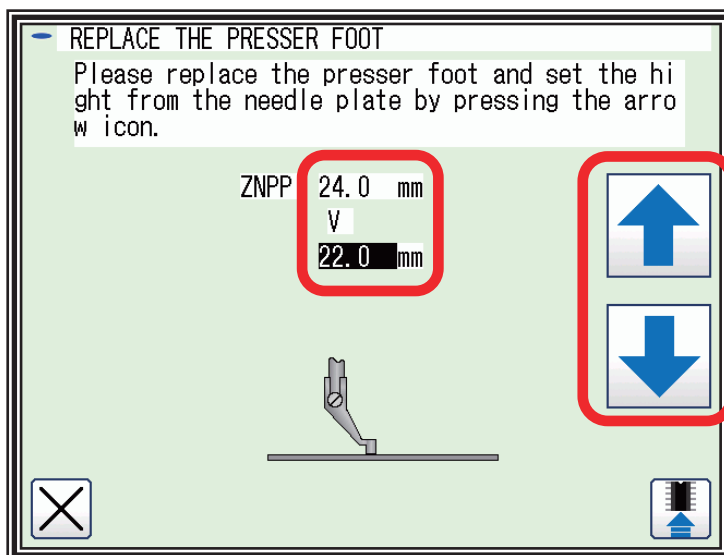
NOTE The ZNPP value can be set every 0.1 mm.



(5) After the completion of setting, press the memory icon  and then press the  icon.

NOTE The ZNPP value is flickering until press the  icon.

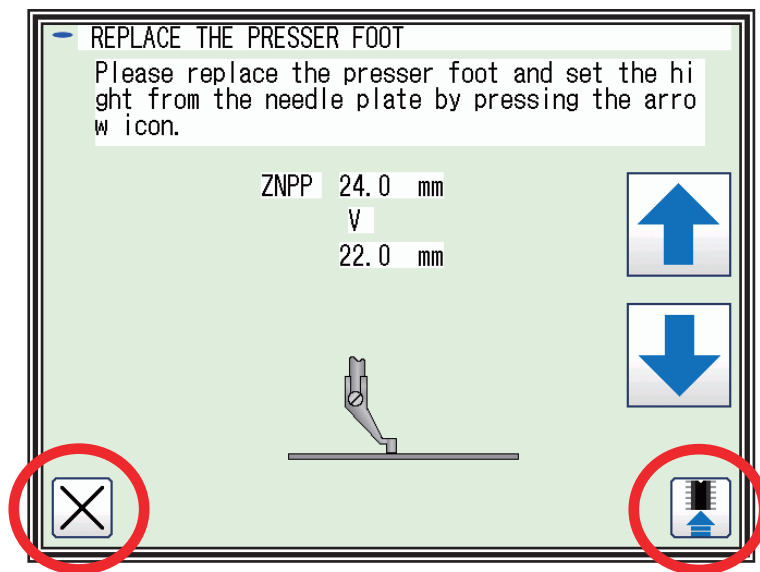

(6) Following the screen indication, put the power switch off.

7-4. Adjustment of the presser foot holder position

- (1) Turn off the machine power and down the presser foot (No.7) by hand to the top of the sliding plate.
- (2) Loosen the each of set screws (No.5) which has presser foot holder (upper) (No.3) and presser foot holder (lower) (No.4).
- (3) Adjust the clearance between the rack gear (No.1) to stopper (No.2) becomes 5 mm by moving the presser foot holder (upper) (No.3) and presser foot holder (lower) (No.4) position.
- (4) After adjustment make sure if the presser foot (No.7) is remaining on the sliding plate. On the other hand, adjust the presser foot hole position to the needle (No.8) with turning the presser bar.
- (5) Then tighten the each of set screws (No.5) securely while holding the block (No.9) by both presser foot holders (No.3), (No.4) and make sure if there are no gap between both presser foot holders (No.3), (No.4) and block (No.9).

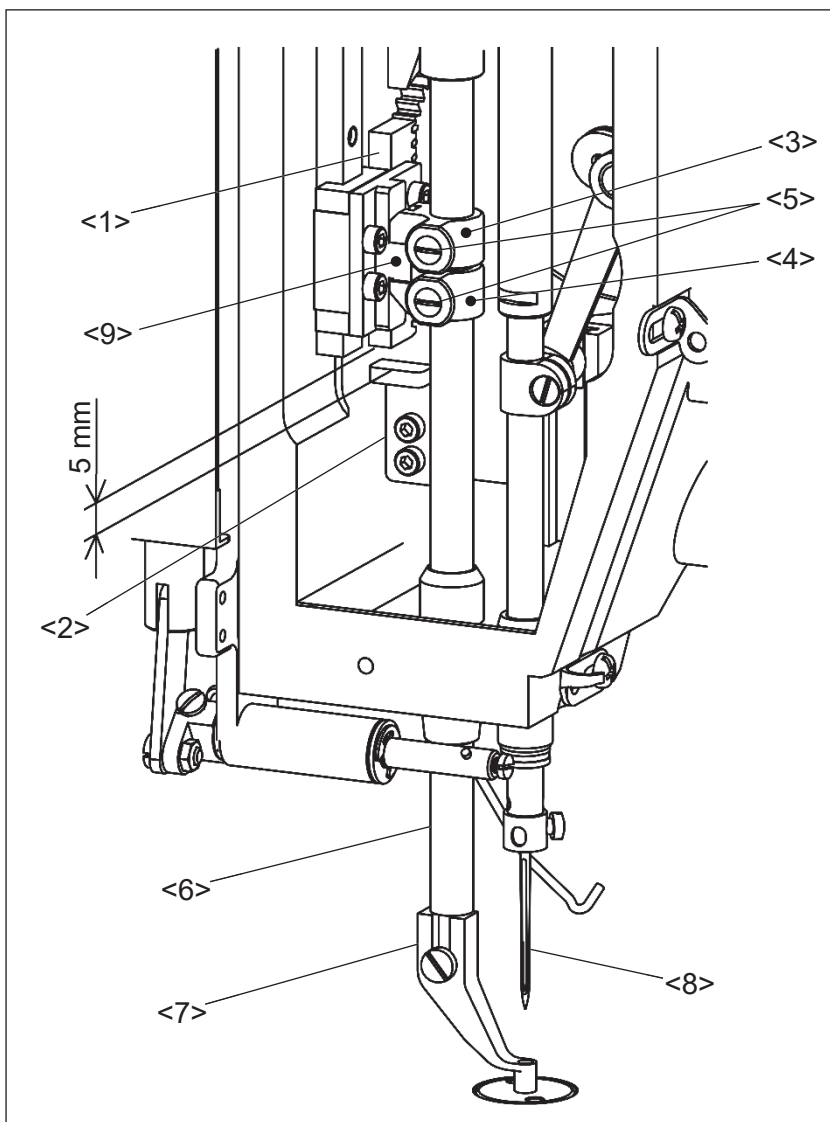

- <1>: Rack gear
- <2>: Stopper
- <3>: Presser foot holder (upper)
- <4>: Presser foot holder (lower)
- <5>: Set screw
- <6>: Presser bar
- <7>: Presser foot
- <8>: Needle
- <9>: Block

7-5 Adjustment of the thread trimmer

7-5-1 Structure of the thread trimmer mechanism

The thread trimmer mechanism of sewing machine is shown on the figure.

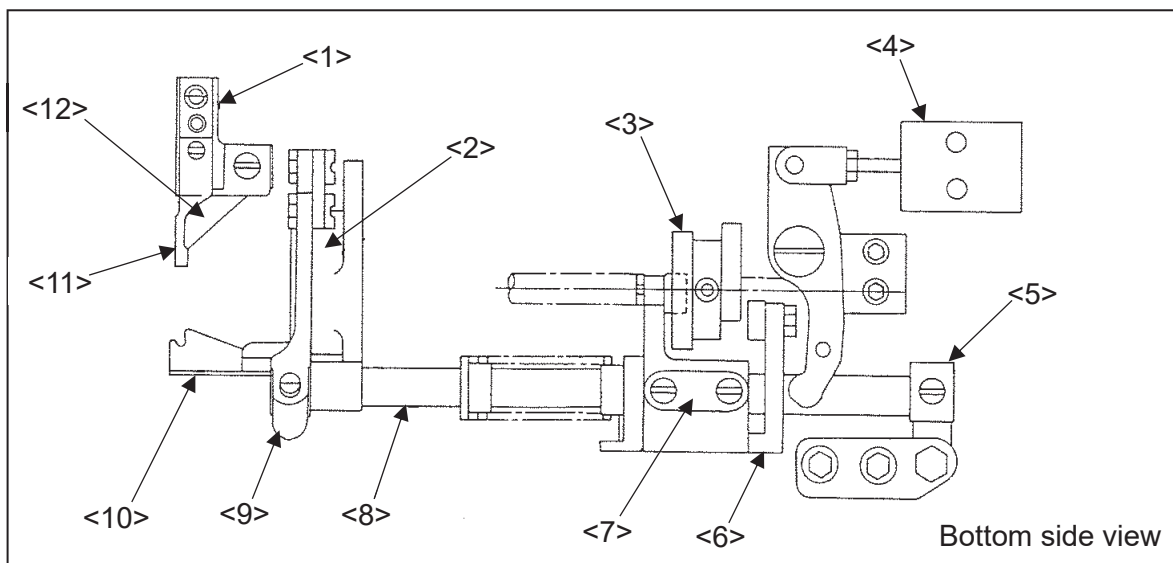

<1>: Knife mounting unit <2>: Knife bracket <3>: Trimming cam <4>: Air cylinder <5>: Stopper
 <6>: Cam follower crank 2 <7>: Cam follower crank 1 <8>:Knife driving shaft <9>:Driving crank
 <10>: Movable knife <11>: Stationary knife <12>: Thread guide

! CAUTION

★A lower shaft cam method is incorporated for the thread trimmer mechanism. When adjusting the sewing machine, if the thread trimmer air cylinder is in the operable state (state in which the cam follower crank 2 arm is engaged with the thread trimmer cam) and the upper shaft is rotated, the movable knife will collide with the needle and cause damage.

For avoiding this incident, always activate the air cylinder only in the regular trimming cycle which the needle moves from its lower to upper position.

7-5-2 Assembling and readjustment of the thread trimmer mechanism

If take the trimmer mechanism apart and assemble it again, please refer to the following instructions for the readjustment.

7-5-2.1 Attaching the knife bracket and the knife mounting unit

(1) Knife bracket

Under the condition that the rotating hook and the hook positioner are removed, put the knife bracket (No.1) on the lower shaft left bushing (No.2) and fix it with the two set screws (No.3).

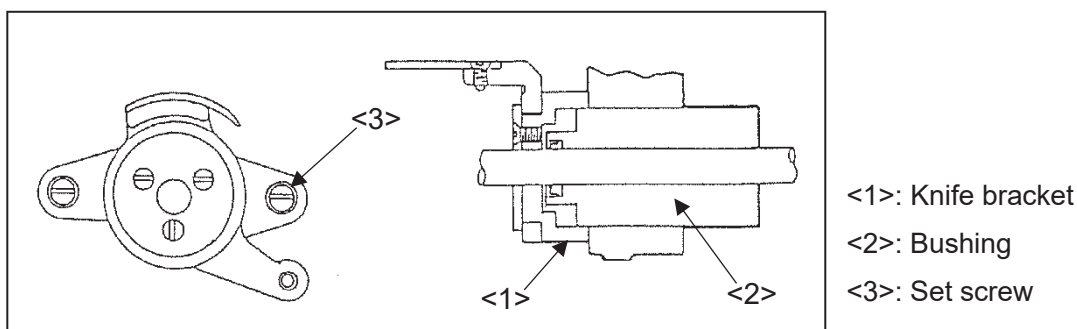

(2) Knife mounting unit

Under the condition that the rotating hook and the hook positioner are removed, attach the knife mounting unit (No.1) with the set screw (No.2).

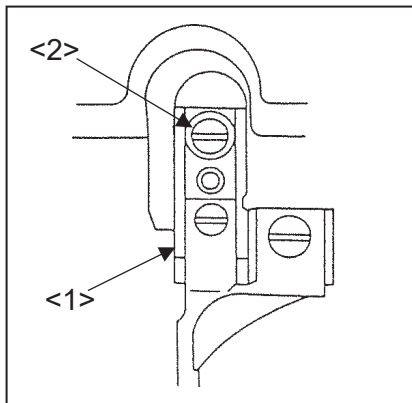

<1>: Knife mounting unit

<2>: Set screw

7-5-2.2 Mutual relation among the movable and stationary knife edge

(1) Rotate the movable knife (No.1) by hand when it is engaged with the stationary knife (No.2), there is 0.3mm space between the movable and stationary knife edges. This is standard condition.

(2) If this space is too wide, it causes a thread tail from the needle to be pulled out after the automatic thread trimming. If it is too narrow, it causes the failure of the trimming. For avoiding these incidents, adjust this space precisely.

(3) For this adjustment, suitably move the knife bracket or the knife mounting unit mentioned at above 7-5-2.1.

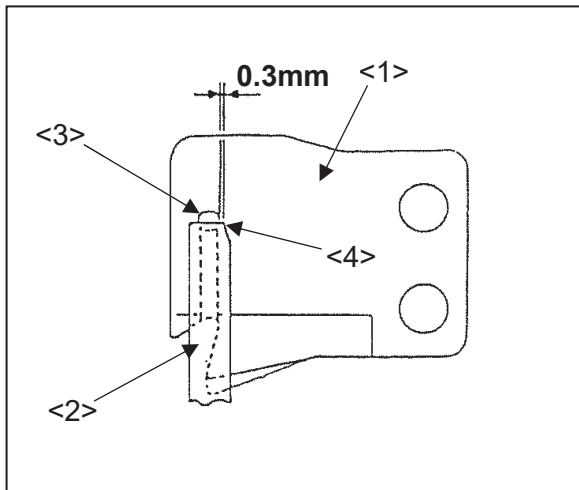

<1>: Movable knife

<2>: Stationary knife

<3>: Movable knife edge

<4>: Stationary knife edge

7-5-2.3 Connection of the knife bracket and the driving crank

- (1) Connect the knife bracket (No.1) and the driving crank (No.2) with the link (No.3).
- (2) Loosen the driving crank set screw (No.4) and adjust the attaching position of the driving crank (No.2) in the right and left direction so that the link (No.3) can contact with the same flat surface of the knife bracket (No.1) and the driving crank (No.2) without any distortion. After the adjustment, tighten the driving crank set screw (No.4) securely.

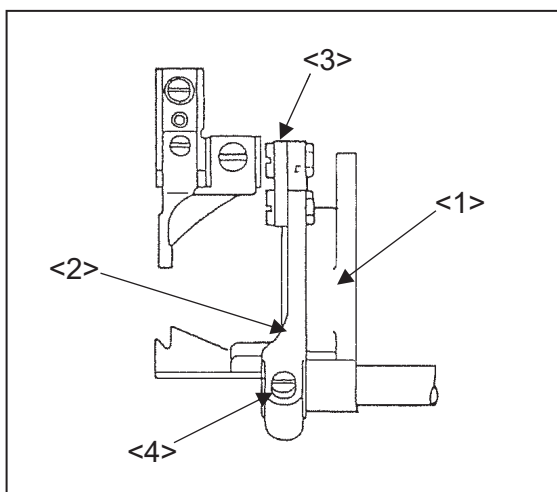

- <1>: Knife bracket
- <2>: driving crank
- <3>: Link
- <4>: Set screw

7-5-2.4 Adjustment of the component parts of the knife driving mechanism

- (1) Attach the component parts of the knife driving mechanism and adjust the locations as shown on the figure.
- (2) When assembling the parts always, firstly insert the knife driving shaft (No.6) into the driving crank (No.1).
- (3) Fix the cam follower crank 1 (No.3) on the knife driving shaft (No.6) at the right end position 77mm away from the front surface of the sewing machine bed as shown on the figure.
- (4) Fix the stopper (No.5) on the knife driving shaft (No.6) by tightening the set screw (No.7) at the flat cut of the shaft. At the time, make sure there is no play on the knife driving shaft (No.6) in the axial direction and it can be rotated smoothly.

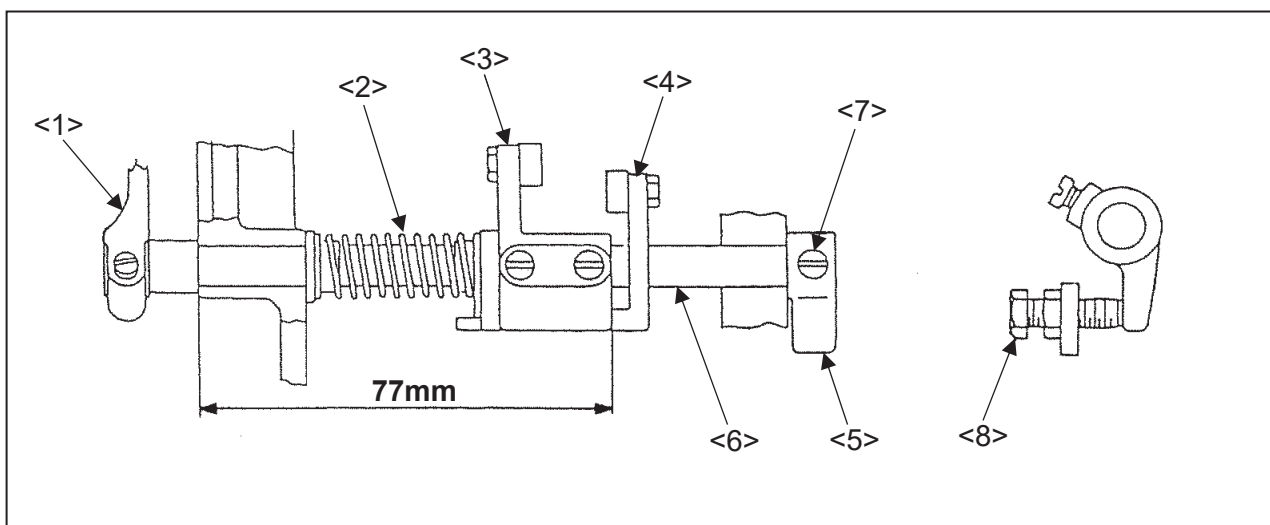

- <1>: Driving crank
- <2>: Spring
- <3>: Cam follower crank 1
- <4>: Cam follower crank 2
- <5>: Stopper
- <6>: Knife driving shaft
- <7>: Set screw
- <8>: Adjusting bolt

7-5-2.5 Adjustment of the mounting position of the air cylinder

(1) Attach the thread trimmer air cylinder (No.1) by fixing with the bolt (No.2). When the thread trimmer air cylinder (No.1) is released, there will be a clearance of approx. 1mm at section **A**. To adjust this clearance, loosen the set screw (No.4) for the mounting plate (No.3), and move the entire mounting plate (No.3).

After adjusting, securely tighten the set screw (No.4) for the mounting plate (No.3).

(2) When the thread trimmer air cylinder (No.1) is activated, there will be a clearance of 0.5mm between the cam follower crank 1 (No.5) and cam follower crank 2 (No.6). This is the standard state. This clearance can be adjusted by loosening nut (No.7) for the air cylinder (No.1), and rotating the shaft section (No.8) of the air cylinder (No.1). After adjusting, securely tighten the nut (No.7) for the air cylinder (No.1).

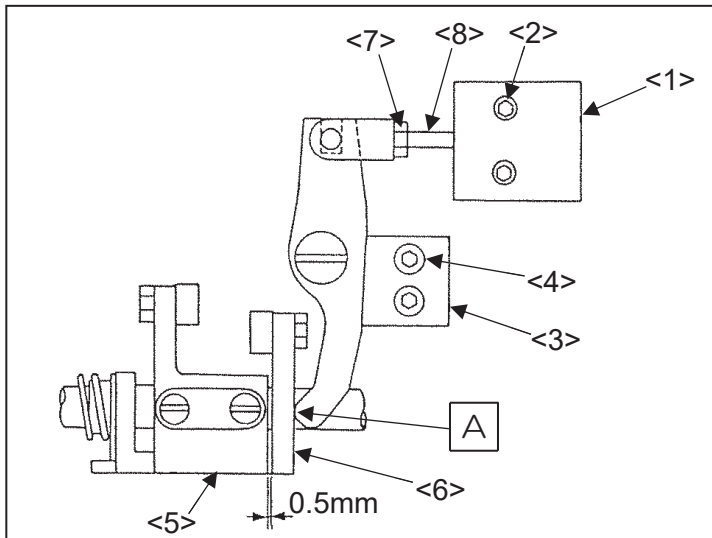

- <1>: Air cylinder
- <2>: Bolt
- <3>: mounting plate
- <4>: Set screw
- <5>: Cam follower crank 1
- <6>: Cam follower crank 2
- <7>: Nut
- <8>: Shaft

7-5-2.6 Adjustment of the mounting position of the thread trimmer cam

Before the trimmer mechanism is activated, the cam follower crank 2 (No.1) is located under the condition that a point of tangency of the cam follower (No.4) is over the tangential line of the knife driving shaft (No.2) and the lower shaft (No.3) at 1.5mm distance. This is the standard condition. Make the following adjustments based upon this standard condition. If this standard condition is changed by such removing the stopper (No.5), set the cam follower crank 2 (No.1) back to the standard condition with the adjusting bolt (No.6).

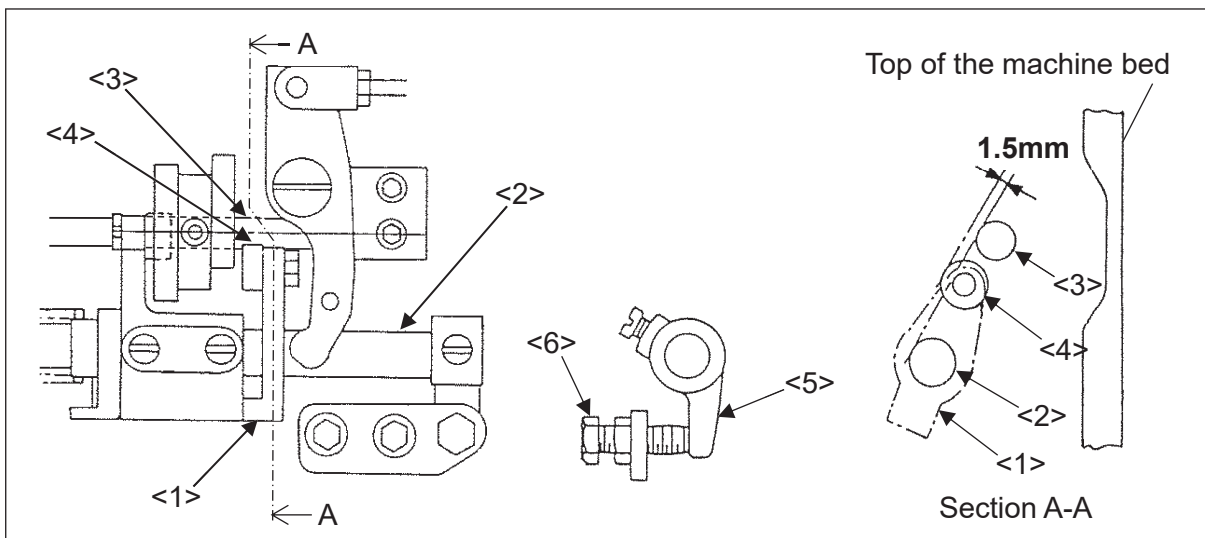

- <1>: Cam follower crank 2
- <2>: Knife driving shaft
- <3>: Lower shaft
- <4>: Cam follower
- <5>: Stopper
- <6>: Adjusting bolt

- (1) Loosen 2 set screws (No.9) of the thread trimmer cam (No.8). Remove the slide plate and place the 4mm thickness gauge (No.10) on the top of sewing machine bed. Move the needle bar downward from its upper position and slide the gauge (No.11) in between the needle bar and the 4mm thickness gauge (No.10). Use the 26.2mm part of T side.
- (2) Make the air cylinder activated condition, then turn the thread trimmer cam (No.8) in the arrow B direction by hand. Fix the thread trimmer cam (No.8) with the two set screws (No.9) at the point where the thread trimmer cam (No.8) contacts with the cam follower (No.13).

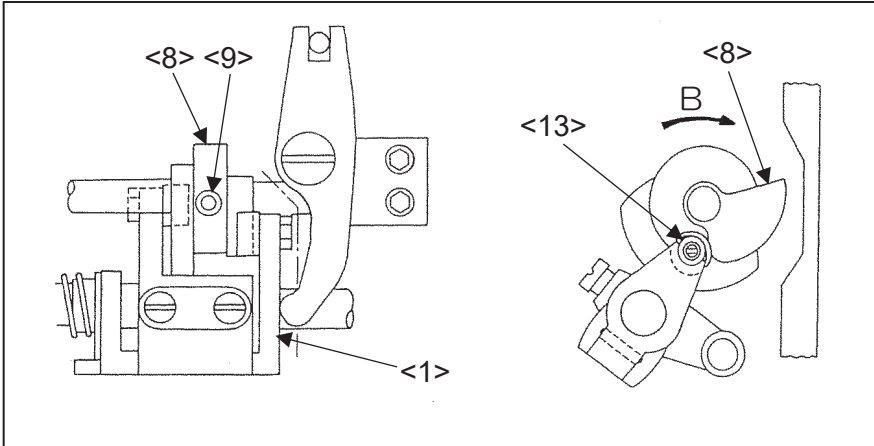

- <1>: Cam follower crank 2
- <8>: Trimmer cam
- <9>: Set screw
- <13>: Cam follower

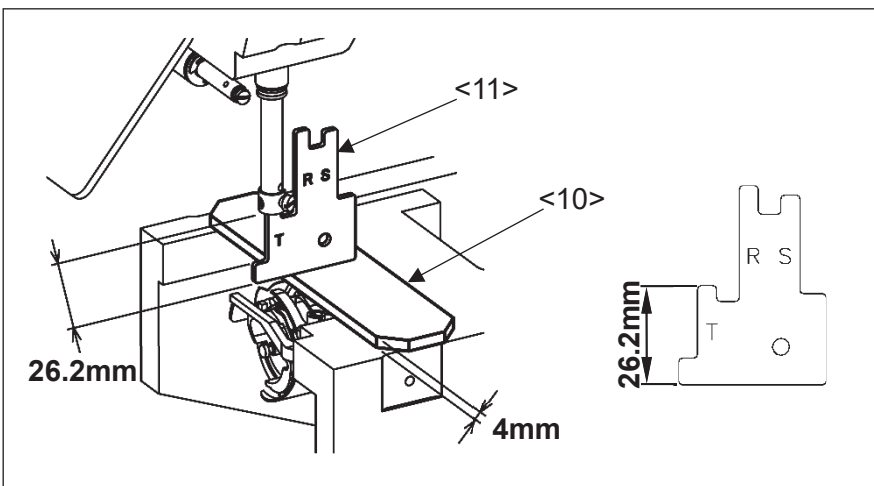

- <10>: 4mm thickness gauge
- <11>: Gauge

- (3) Make sure that the clearance between the thread trimmer cam (No.8) right end and the cam follower (No.13) left end is 0.5mm to 1.0mm when the cam follower crank 2 (No.1) is returned to the C arrow direction after the air cylinder is set back to the original condition. This is the standard condition.

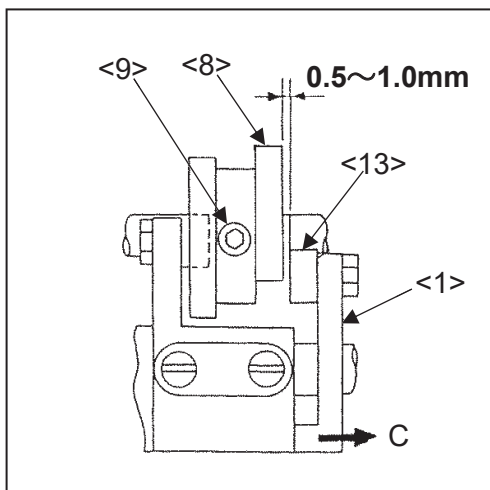

- <1>: Cam follower crank 2
- <8>: Trimmer cam
- <9>: Set screw
- <13>: Cam follower

7-5-2.7 Adjustment of the knife engagement

(1) The standard position for the movable and stationary knife

The standard mutual position for the movable knife (No.1) and stationary knife (No.2) is as shown on the figure.

(2) Adjustment of the amount for the knife engagement

Activate the thread trimmer air cylinder, and rotate the upper shaft. The movable knife (No.1) will rotate with the thread trimmer cam. When the edge of movable knife (No.1) is reached at most left position, the amount of the engagement with the stationary knife (No.2) becomes 1.5mm to 2.0mm. This is the standard condition. For this adjustment, loosen the set screw (No.4) of the driving crank (No.5), then move the driving crank (No.5) to have the proper engagement. After the adjustment, tighten the set screw (No.4) of the driving crank (No.5) securely.

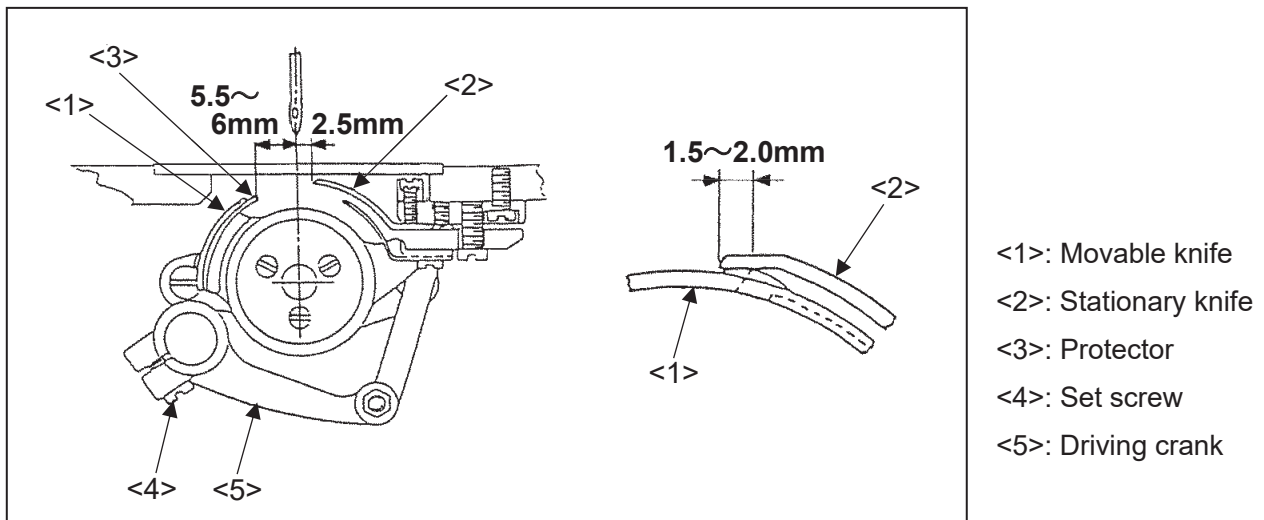

(3) Adjustment of the engaging presser for the knives

- a) The engaging presser for the movable knife (No.1) and stationary knife (No.2) can be controlled with adjusting the height of the stationary knife (No.2). When the movable knife (No.1) is rotated, the contact of the both knives starts from the position where the distance between the edge of the stationary knife (No.2) and the cut out line of the movable knife (No.1) is 3mm. This is the standard condition.
- b) If the trimming condition is not sharp enough to a bigger thread, it can be improved with increasing the knife engaging presser a little.
- c) For the adjustment of this knife engaging presser, after removing the slide plate and loosening the lock nut (No.4), use the adjusting screw (No.5). If tighten the adjusting screw (No.5), the knife engaging presser becomes tight and if loosen the adjusting screw (No.5), it becomes loose. After the adjustment, tighten the lock nut (No.4) securely.

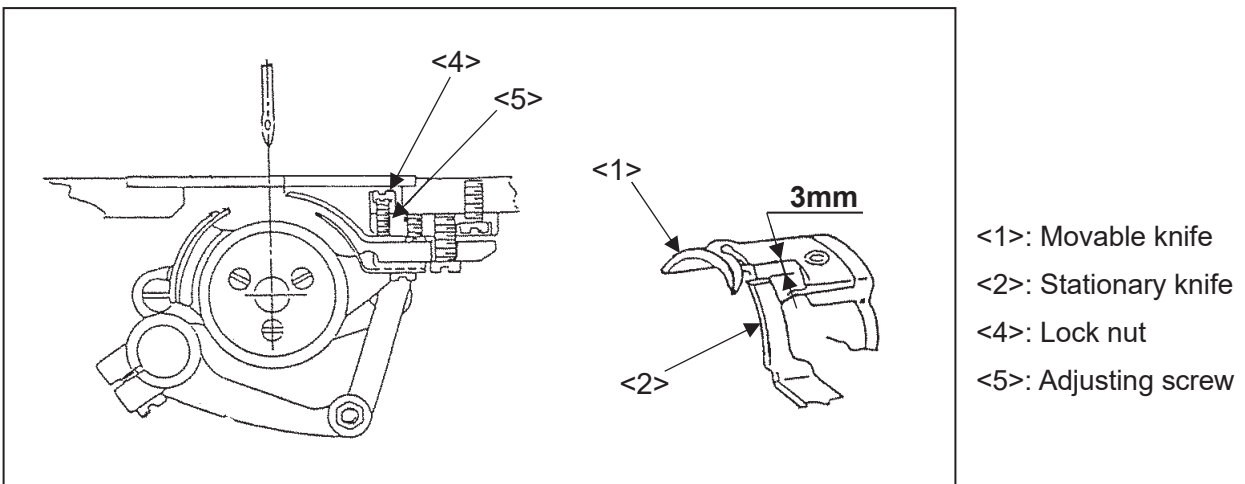

(4) Adjustment of the attaching position of the protector

Attach the protector (No.6) underneath the movable knife (No.1) and fix it with the same set screw (No.7) for the movable knife (No.1) at the position where the point of the protector (No.6) is off 0.5mm left from the needle center (No.8) and 4mm backward from the point of the movable knife (No.1).

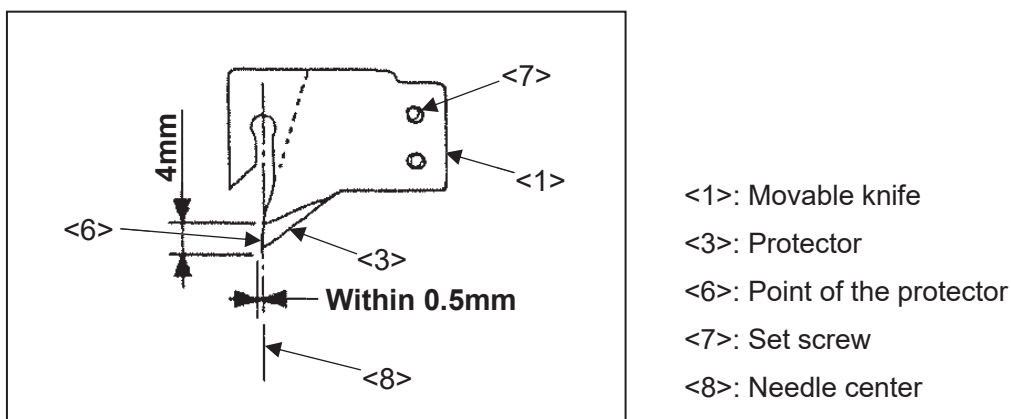

7-6. Adjustment of the X-Y table detector

7-6-1. Adjustment of the X-Y mechanical home position

The mechanical home position (No.1) is fixed at the center of the sewing area as the factory default setting.

The machine can be moved within the area (No.2) covered with diagonal lines.

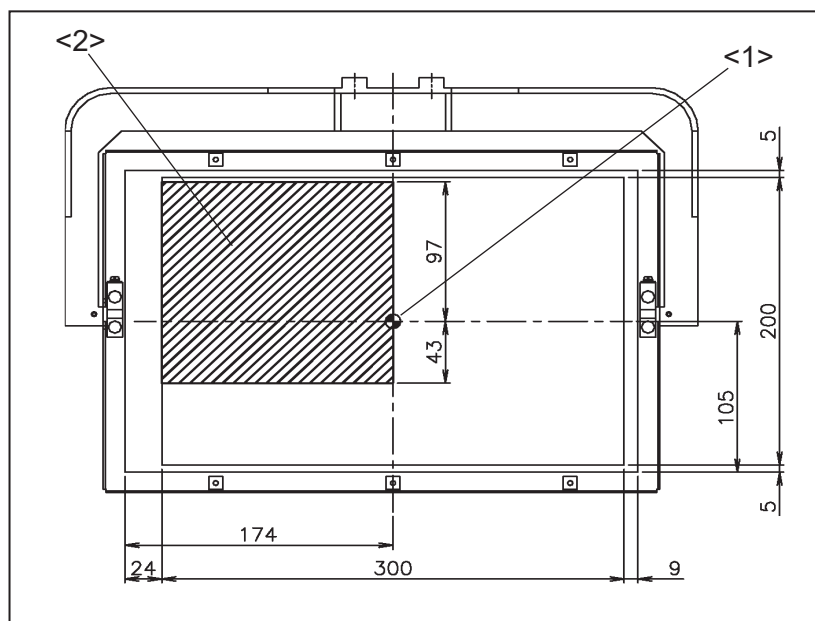



<1>: Home position as the factory default <2>: Adjustable area

(1) After canceling the sewing area limit, change the mechanical home position.

(2) Press the  on the standard screen to open the MENU mode.

(3) Press the  ->  ->  [Cancellation of sewing area limit] in order.

(4) Select the  on the [Cancellation of sewing area limit] screen, and press the .

(5) When turning the power off then, the setting of the sewing area limit is cancelled.

NOTE When modify the home position somewhere other than the center of sewing area, please refer to the instructions **OPERATION PANEL** technical manual [18] [Easy setting 3-(5)].

7-6-2. Adjustment of the X direction

- (1) Turn the power switch off.
- (2) Remove the covers on the top of the sewing machine bed.
- (3) The mechanical home position of the X direction is the position where the detector (No.2) can detect the edge of the detector plate X (No.1).
- (4) For the adjustment of the X direction mechanical home position, loosen the detector plate set screws (No.3) at the left and right side then, move the detector plate X in the arrow direction as shown on the figure. Set the clearance between the detector plate X and the detector within the range of 1.0 to 1.5mm.
- (5) Turn the power switch on. Press the home position return icon , and check the mechanical home position.
- (6) If the mechanical home position is not the desired position, carry out the same procedure (4) and (5) again. In that case, turn the power switch off each time.

NOTICE The machine has a function that the motor memorizes the home position at the first home position returning operation after the switch is turned on. Therefore, from the second home position returning, it does not use the home position return sensor. Make sure to turn the power switch off to change the mechanical home position.

To use the sensor from the send returning, press **Program** → home position → **SHP**

[Home returning method since the second time returning] on the standard screen and set it ON.

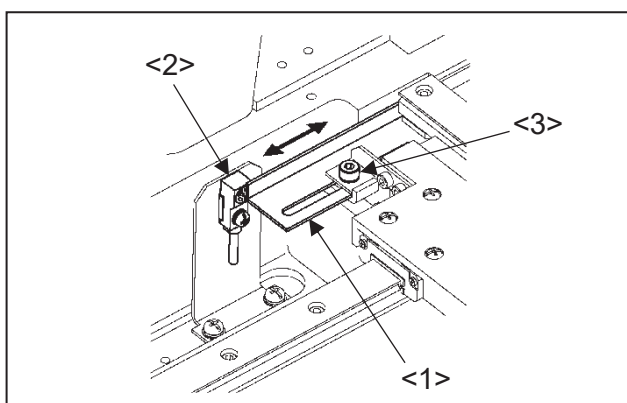

- <1>: Detector plate X
- <2>: Detector
- <3>: Detector plate set screw

7-6-3. Adjustment of the Y direction

- (1) Turn the power switch off.
- (2) The mechanical home position of the Y direction is the position where the detector (No.2) can detect the edge of the Y drive shaft (No.1).
- (3) For the adjustment of the Y direction mechanical home position, loosen the detector set screw (No.3) then, move the detector to the arrow direction as shown on the figure.
- (4) Turn the power switch on. Press the home position return icon , and check the mechanical home position.
- (5) If the mechanical home position is not the desired position, carry out the same procedure (3) and (4) again. In that case, turn the power switch off each time.

NOTICE The machine has a function that the motor memorizes the home position at the first home position returning operation after the switch is turned on. Therefore, from the second home position returning, it does not use the home position return sensor. Make sure to turn the power switch off to change the mechanical home position.

To use the sensor from the send returning, press **Program** → **home position** → **SHP**

[Home returning method since the second time returning] on the standard screen and set it ON.

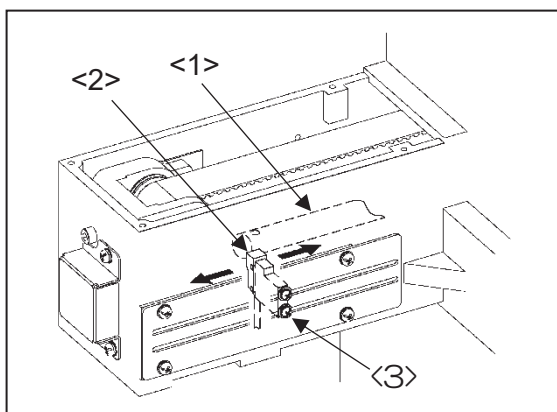

- <1>: Y drive shaft
- <2>: Detector
- <3>: Detector set screw

7-6-4. The X-Y drive timing belt tension

The X-Y drive timing belt tension is as follows as the factory default setting.

X : 200 (N) ± 10% Y : 200 (N) ± 10%

8. MAINTENANCE



- (1) Please make sure to turn the power switch off before cleaning the sewing machine.
- (2) Please pay attention to that staining your skin or eyes with oil may cause an inflammation.

8-1. Cleaning

Remove the dust and the thread waste sticking regularly.

8-2. Greasing

- (1) The dust or the like sticking absorbs lubrication oil on the rails and significantly lowers the slide guide running life. Remove the dust and the thread waste sticking regularly and greasing every six months. For the guide rail, grease to the both side of guide groove. After greased, apply the grease uniformly by moving the XY table by hand.

Recommended grease: Lithium grease 2

- (2) Grease every six months to the following units which consisted by gear mechanism.

NOTE Remove the face cover and other covers in advance.

<1>: Rack gear which has presser foot unit.

<2>: Gear of the needle thread tensioner drive unit.

Recommended grease: Molybdenum disulfide grease

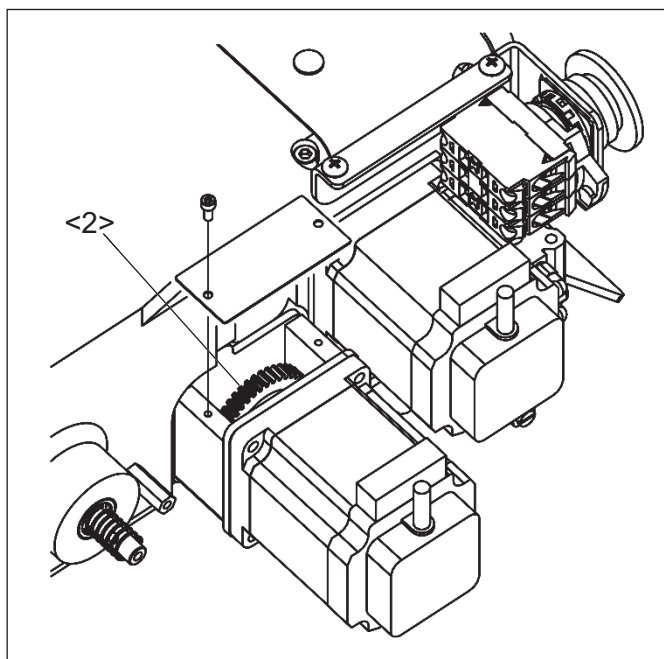
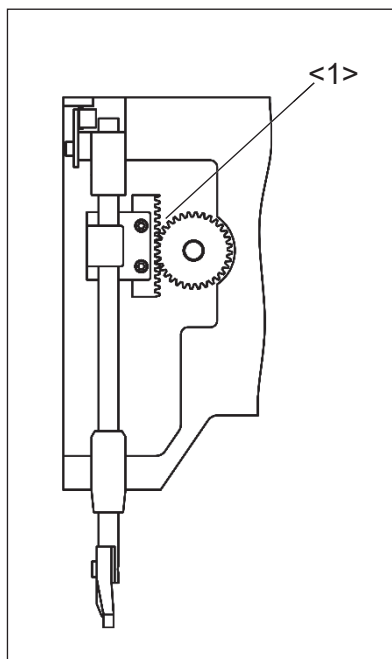

8-3. Disposing of oil waste

If the oil bottle (No.1) is full filled with waste oil, remove the oil bottle and dispose it regularly.

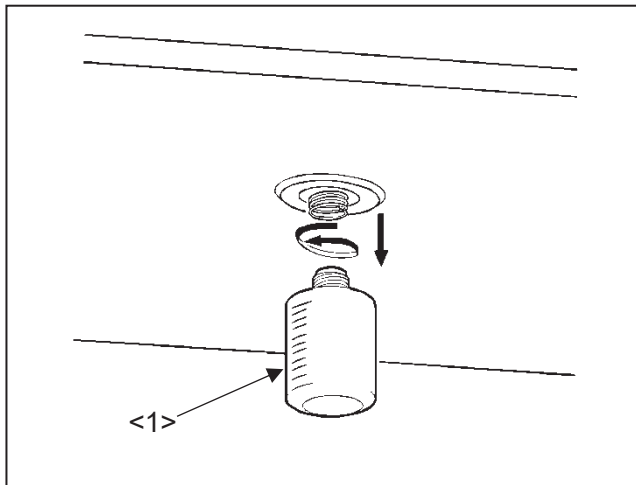

<1>: Oil bottle

9. TROUBLESHOOTING



CAUTION

(1) Please make sure to turn the power switch off before adjusting the sewing machine.

(2) If the adjustment is required while the power switch on, do not step on the foot switch by mistake.

Condition	Cause	Corrective action	Reference
Upper thread is broken.	Upper thread tension is too tight.	Adjust thread tension.	5-9
	Strength of thread take up spring is inappropriate.	Adjust thread take up spring.	6-8-2
	Parts on needle plate, hook, and presser foot touching thread are damaged.	Grind parts or change parts.	-
	The needle size is bigger than the thread size.	Change the needle size to suitable size.	5-2
	Thread melts with heat.	Slow down the sewing speed	Operation panel section
Use needle cooler.		-	
Bobbin thread is broken.	Bobbin thread tension is too tight.	Adjust thread tension.	5-8
	Parts on needle plate and presser foot touching thread are damaged.	Buff parts or change parts.	-
	Bobbin case size is smaller than the thread size.	Change the thread size to suitable size.	-
Upper thread is pulled from needle hole when starting sewing.	Thread take up spring tension is too much.	Adjust thread take up spring tension.	6-8-2
	Thread tail is short. (Pre-tensioner spring is too tight.)	Adjust thread tail with pre-tension.	6-9
	Sewing speed is inappropriate when starting sewing	Use [e-stitch] function. (Program mode > Sewing speed group > OPLC is ON)	Operation panel section

Frequent skip stitching happens.	Clearance between needle and hook is too big.	Adjust clearance between needle and hook properly.	6-2
	Timing of needle and hook is not proper.	Adjust position of needle and hook properly.	6-2
	Needle is bent.	Change needle.	5-2
	Needle is at wrong position.	Fix position properly.	5-2
	Presser foot position is not proper.	Adjust presser foot position.	6-6
	Presser foot up and down timing is not proper.	Adjust presser foot up and down properly.	6-6
Trimming is not functioned.	Fixed knife is dull.	Sharpen fixed knife or change fixed knife.	-
	Movable and fixed knife position is not proper.	Adjust movable and fixed knife position.	7-5-2.7
	Knife engaging presser is not proper.	Adjust the knife engaging presser.	7-5-2.7
	Skip stitching happens in trimming.	Refer to the condition "Frequent skip stitching happens".	-
	Setting of trimming timing is not proper	Adjust the trimming timing.	Operation panel section
	Trimming setting is off.	Turn trimming setting on.	Operation panel section
Needle thread is pulled from needle hole after trimming	Thread release timing is not proper.	Adjust the thread release timing.	Operation panel section
	Threading way of the needle thread is not proper.	Thread the needle thread properly.	5-3
	Pre-tensioner spring is too tight. (Thread tail is short.)	Adjust the intensity of the pre-tensioner spring.	6-9

Stitch forming is loose.	Upper thread tension is too loose.	Adjust upper thread tension.	5-9
	Bobbin thread tension is too loose.	Adjust bobbin thread tension.	5-8
	Strength of thread take up spring is inadequate.	Adjust strength of thread take up spring.	6-8-2
	Presser foot position is not proper.	Adjust presser foot position properly.	6-6
	Presser foot up and down timing is not proper.	Adjust presser foot up and down properly.	6-6
	Sewing material is not held	Hold the sewing material sufficiently.	-
Work holder does not fall.	Foot switch is broken.	Change foot switch.	-
	Air presser is not strong enough	Increase air presser	6-10
Wiper system does not work.	Wiper hits needle or presser foot.	Adjust wiper position.	6-7
	Wiper setting is turned off.	Turn wiper setting on.	6-7
Sewing pattern is changed.	Sewing material is not pressed properly.	Adjust work holder pressure.	6-10
	Sewing material in work holder slips.	Put slip stopper on presser plate.	-
	Sewing material is too heavy.	Slow down sewing speed.	Operation panel section
	X-Y timing belt tension is loose.	Adjust timing belt tension properly.	7-6-4
Returned home position is changed.	Ambient temperature is out of use range.	Use sewing machine in ambient temperature in 5 degrees to 35 degrees.	-
	Clearance between detector and detecting subject is too wide.	Adjust clearance in 1 to 1.5mm.	7-6-2
Oil consumption of the machine head is too much	Oil amount is too much.	Reduce the oil amount	6-5
Oil consumption of the hook is too much	Oil amount is too much.	Reduce the oil amount	6-4

10-1. Air piping drawing

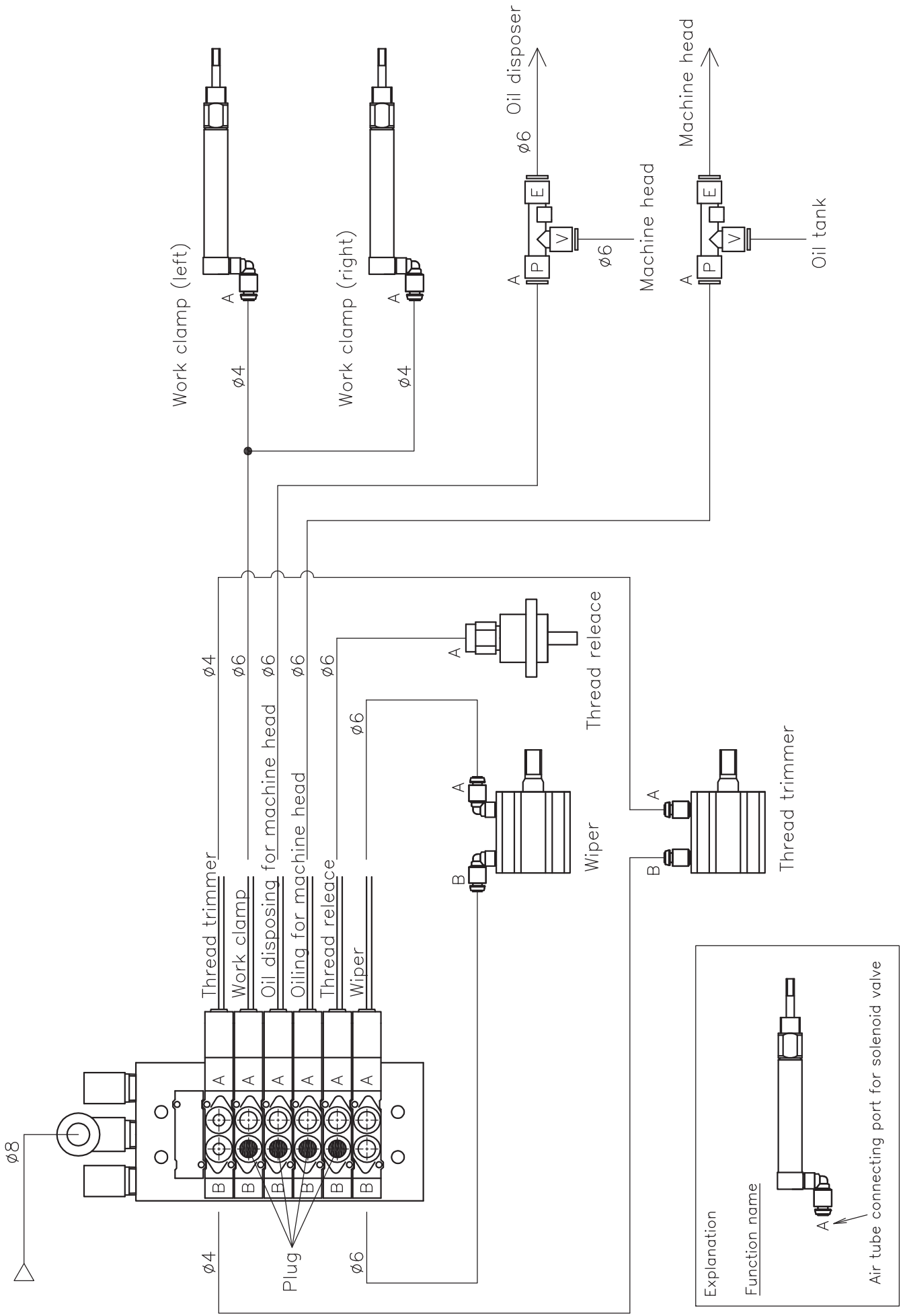

10-2. Steel stand drawings

MEMO If the steel stand is not original, produce the parts with reference to the following drawings.

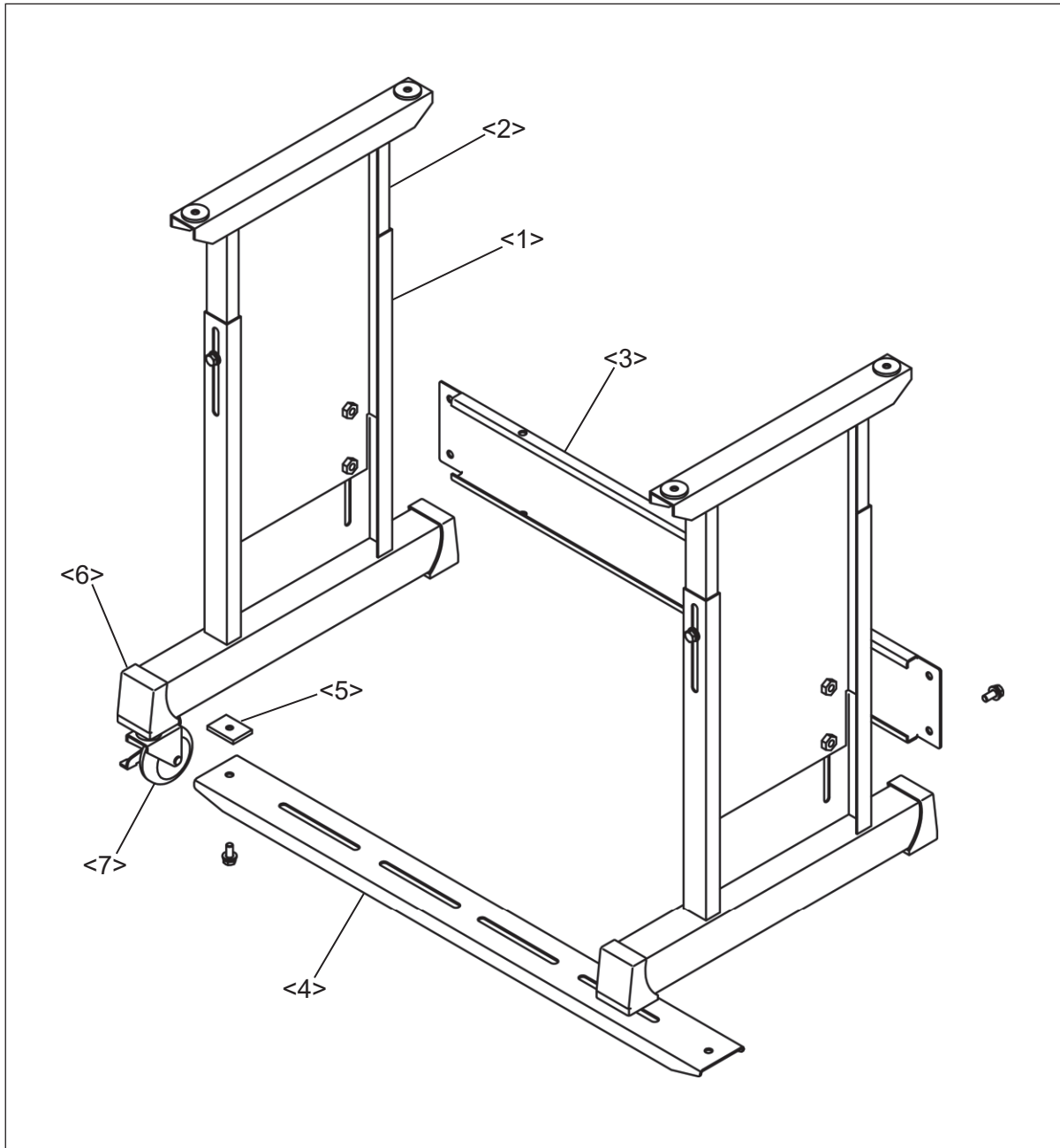

Stand part <1>...Thickness 2mm

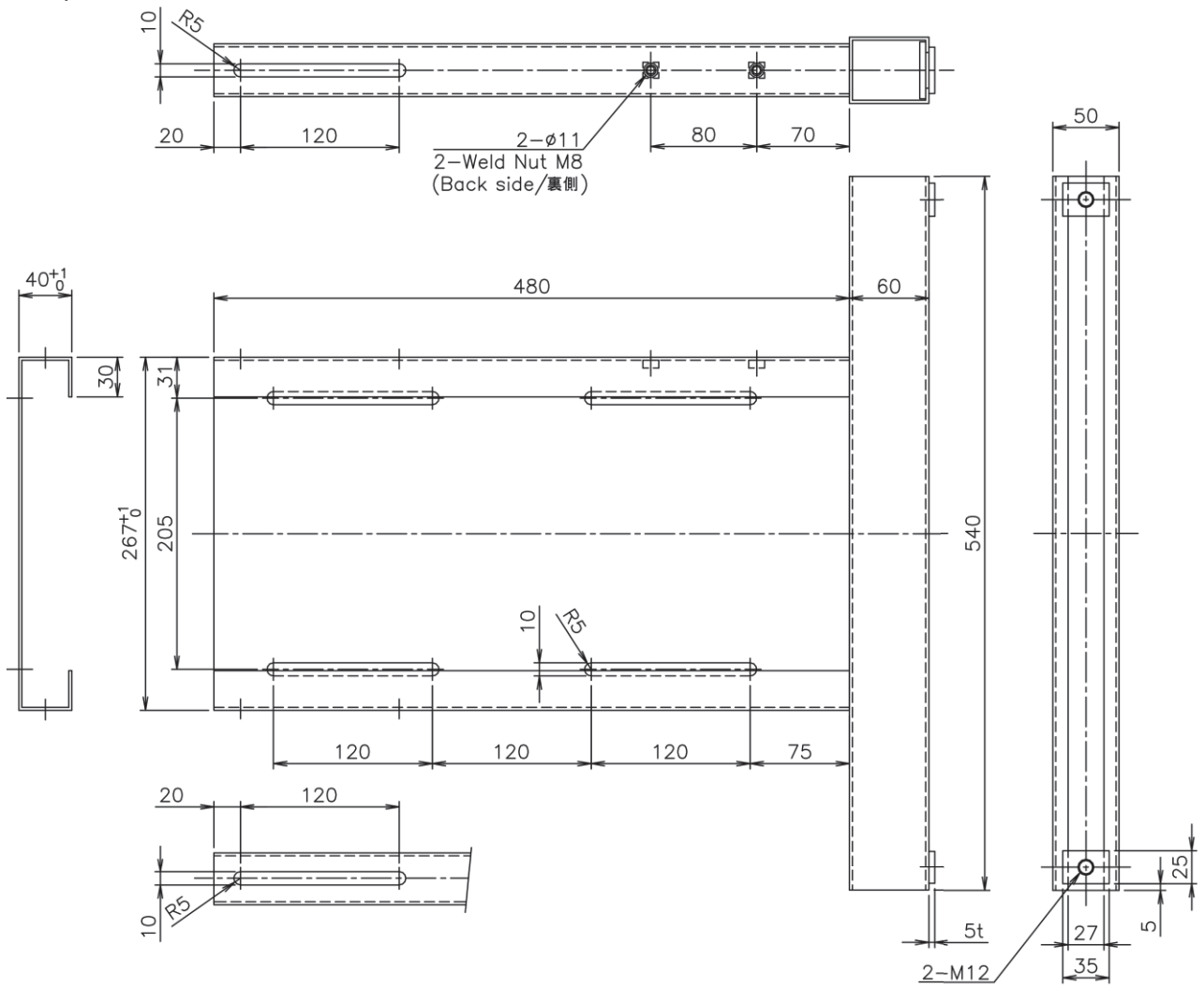

Stand part <2>...Thickness 2mm

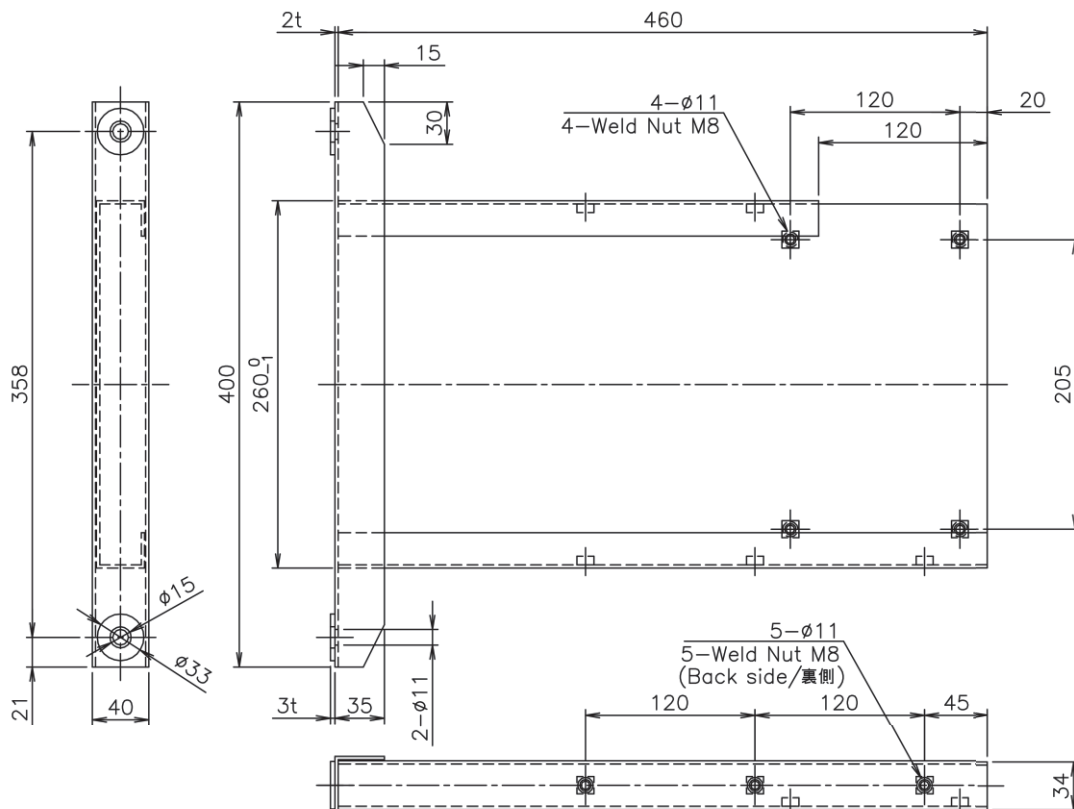

Stand part <3>...Thickness 2mm

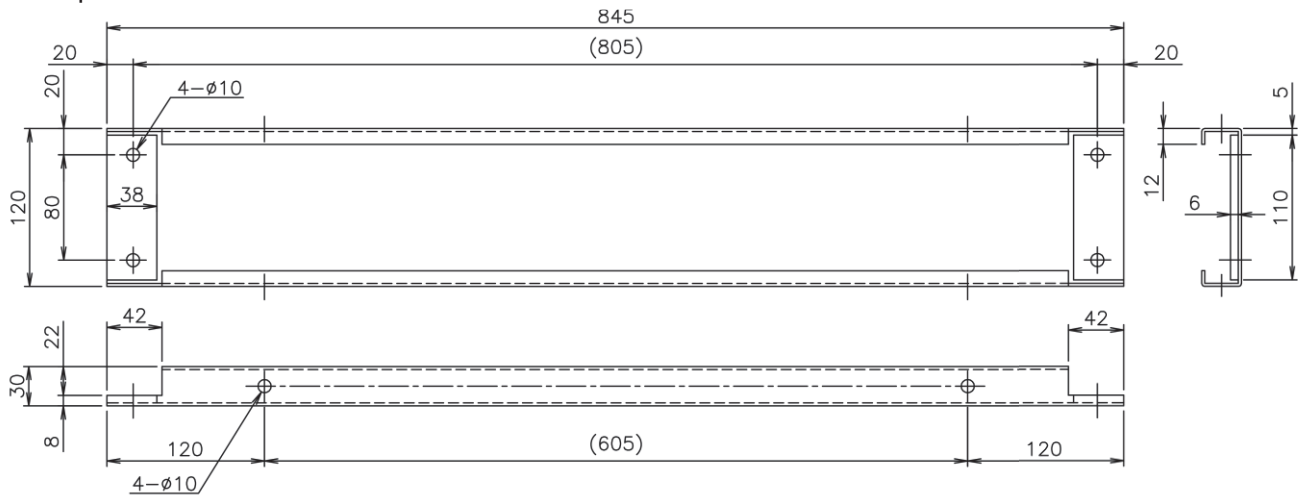

Stand part <4>...Thickness 2mm

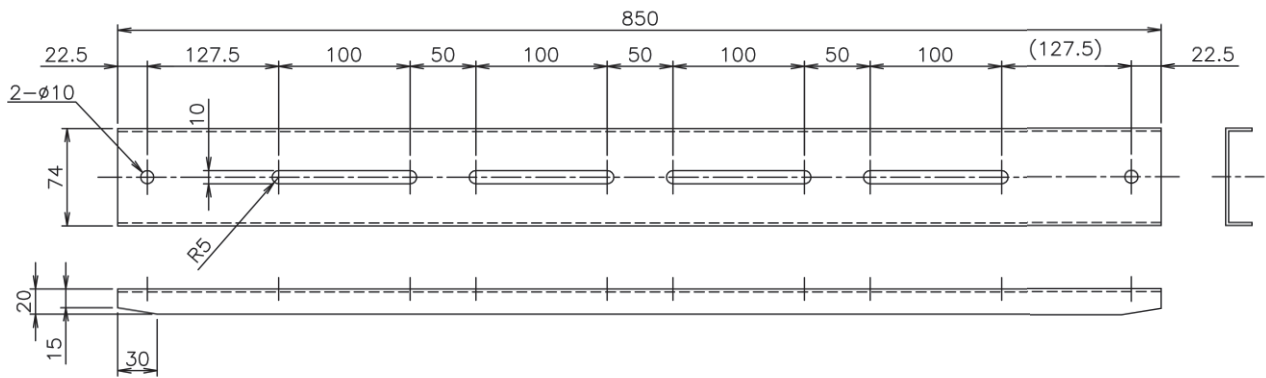

Stand part <5>...Thickness 5mm

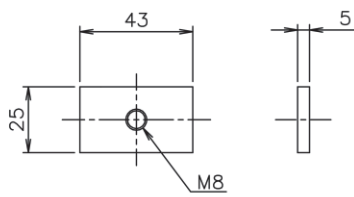

Stand part <6>...Rubber thickness 2.5mm

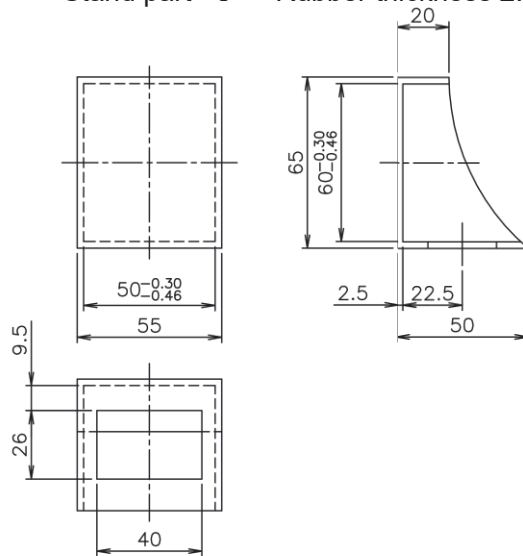

Stand part <7>...Permissible load more than 60kg
(Per wheel)

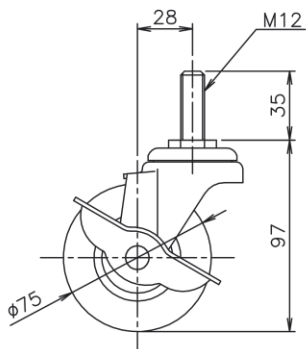

JUKI CORPORATION

Printed in Japan