

ENGLISH

**MF-7900
INSTRUCTION MANUAL**

CONTENTS

I . SPECIFICATIONS	1
II . CONFIGURATION OF THE MACHINE COMPONENTS	2
III . INSTALLATION	3
1. Installing the machine head onto the table	3
2. Selecting the motor pulley and the belt.....	9
3. Installing the motor.....	9
4. Setting the belt	9
5. Installing the belt cover.....	10
6. Installing the chain	10
7. Installing the thread guide	10
8. Installing the needle bar thread take-up cover	11
IV . LUBRICATION AND OILING	11
1. Lubricating oil	11
2. Oiling.....	11
3. Silicon oil lubricating unit.....	12
V . OPERATION.....	12
1. Needle	12
2. Attaching the needle.....	12
3. Threading the machine head	13
(1) Standard threading	13
4. Adjusting the stitch length.....	14
5. Adjusting the differential feed ratio	14
6. Adjusting the presser foot pressure.....	15
7. Adjusting the thread tension	15
VI . ADJUSTING THE SEWING MACHINE.....	16
1. Adjusting the silicon container thread guide.....	16
2. Adjusting the needle bar thread take-up thread receiver	16
3. Adjusting the rocking thread take-up	17
4. Adjusting the spreader thread guide	17
5. Adjusting the looper thread cam thread guide and the looper thread cam	17
6. Adjusting the looper	18
7. Adjusting the height of the needle	18
8. Adjusting the rear needle guard.....	19
9. Relation between the rocking thread take-up timing and the needle thread loop	19
(1) Adjustment by the crank	19
(2) Adjustment by the eccentric cam	20
10. Adjusting the height of the feed dog	21
11. Installing position of the spreader	21
12. Adjusting the spreader thread guide and the needle clamp thread guide.....	22
13. Adjusting the front needle guard	22
14. Adjusting the presser foot lift.....	23
15. Adjusting the micro-lifter	23
16. Adjusting the feed locus	24
(1) Retarding the feed driving motion.....	24
(2) Retarding the feed rocking motion.....	25
17. Adjustment value of balloon.....	26
VII . MAINTENANCE	28
1. Cleaning the sewing machine.....	28
2. Replacing the lubricating oil	28
3. Inspecting and replacing the oil filter	28

I . SPECIFICATIONS

Model name	High-speed, cylinder-bed coverstitch machine
Model	MF-7900 series
Stitch type	ISO standard 406, 407, 602, and 605
Example of application	Hemming and covering for knits and general knitted fabrics
Sewing speed	Max. 6,500 sti/min (at the time of intermittent operation) V-belt type 6,000 sti/min (at the time of intermittent operation) Direct-drive type Speed of stitch at the delivery. 4,500 sti/min (at the time of intermittent operation)
Needle gauge	3-needle ... 5.6 mm and 6.4 mm 2-needle ... 3.2 mm, 4.0 mm and 4.8 mm
Differential feed ratio	1 : 0.9 to 1 : 1.8 (stitch length : less than 2.5 mm) (1:0.6 to 1:1.1, when the differential link hinge screw is changed) Micro-differential feed adjustment mechanism is provided. (Micro-adjustment)
Stitch length	0.9 mm to 3.6 mm (can be adjusted up to 4.5 mm)
Needle	UY128GAS #9S to #12S (standard #10S)
Needle bar stroke	31mm (33 mm, when the eccentric pin is changed)
Dimensions	(Height) 450 x (Width) 468 x (Length) 264
Weight	42 kg
Lift of presser foot	8 mm (needle gauge : 5.6 mm without top covering), and 5 mm (with top covering) Micro-lifter mechanism is provided.
Feed adjustment method	Main feed ... dial type stitch pitch adjustment method Differential feed ... lever adjustment method (micro-adjustment mechanism is provided.)
Looper mechanism	Spherical rod drive method
Lubricating system	Forced lubrication method by gear pump
Lubricating oil	JUKI GENUINE OIL 18
Oil reservoir capacity	Oil gauge lower line : 600 cc to upper line : 900 cc
Installation	Table-fixed type, Semi-submerged type
Noise	- Equivalent continuous emission sound pressure level (L_{pA}) at the workstation : A-weighted value of 79.5 dB; (Includes $K_{pA} = 2.5$ dB); according to ISO 10821- C.6.2 -ISO 11204 GR2 at 4,500 sti/min.

II. CONFIGURATION OF THE MACHINE COMPONENTS

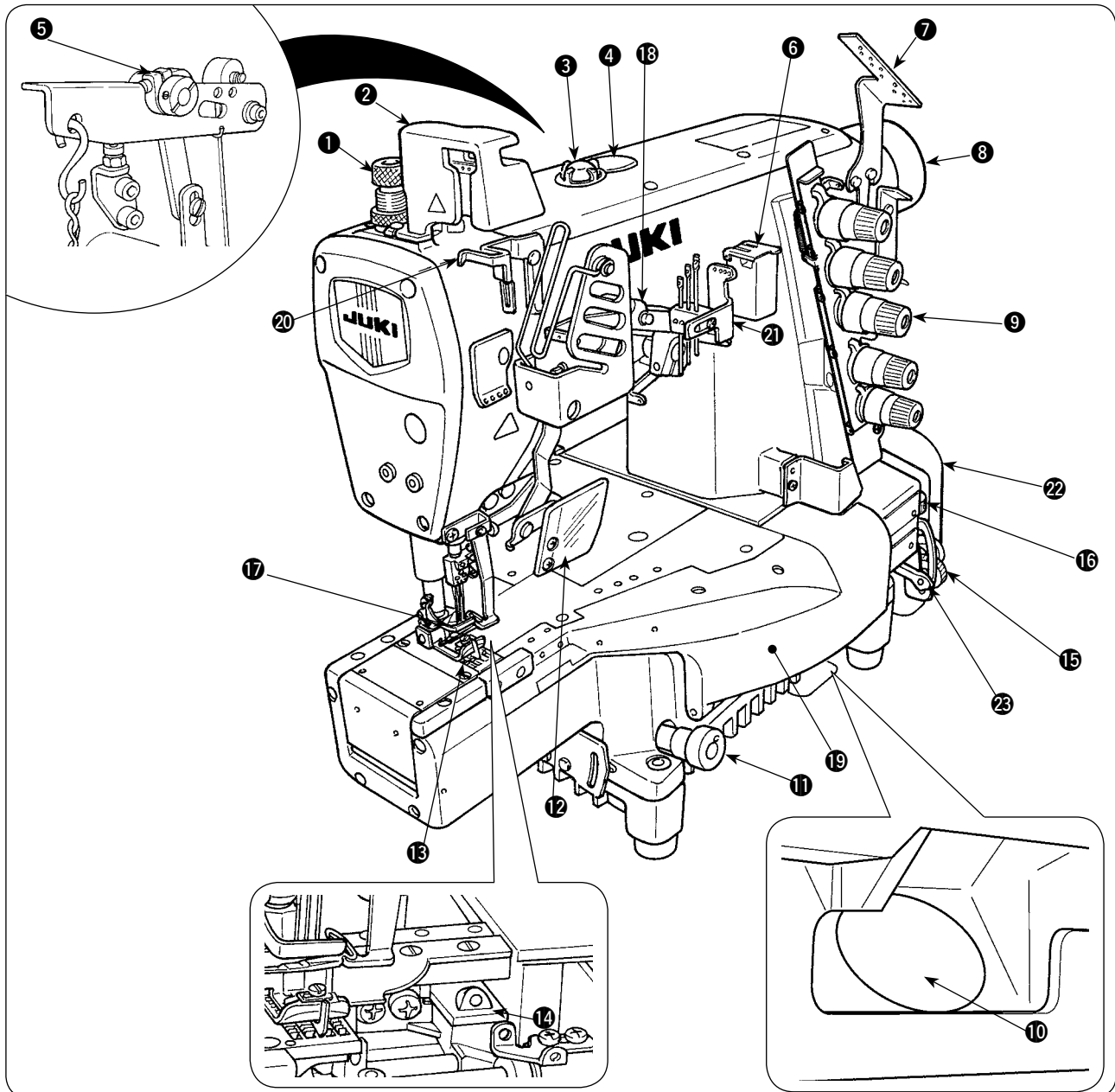

- | | |
|--|---|
| ① Presser spring regulator | ⑭ Needle tip silicon oil lubricating unit |
| ② Needle bar thread take-up cover | ⑮ Differential lock nut |
| ③ Oil circulation inspection windows | ⑯ Micro-adjustment knob |
| ④ Oil hole cap | ⑰ Finger guard |
| ⑤ Micro-lifter | ⑱ Rocking thread take-up |
| ⑥ Needle thread silicon oil lubricating unit | ⑲ Front cover |
| ⑦ Thread guide No. 1 | ⑳ Needle bar thread take-up thread receiver |
| ⑧ Upper pulley | ㉑ Silicon container thread guide |
| ⑨ Thread tension nut | ㉒ Belt cover |
| ⑩ Oil gauge | ㉓ Differential feed regulating lever |
| ⑪ Feed regulating knob | |
| ⑫ Eye guard cover | |
| ⑬ Throat plate | |

III. INSTALLATION



WARNING :

Do not insert the power plug of the motor into the receptacle until all works have been completed. There is a danger of injury by being caught in the machine.

1. Installing the machine head onto the table



WARNING :

The weight of the sewing machine is more than 42 kg. Be sure to perform the work with two persons or more in case of unpacking, transportation or installation.

[For the V-belt type]

Table-fixed type

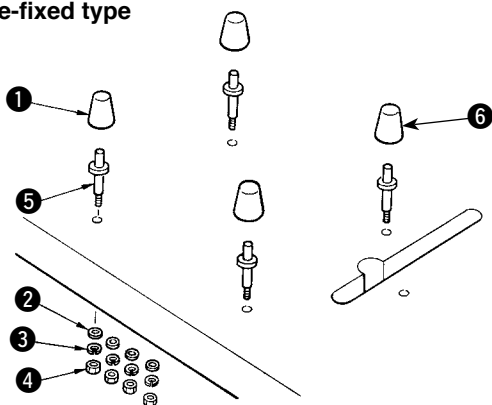

Attach the pins and the rubber cushions as shown in the illustration and properly install the sewing machine.

- ① Rubber cushion (Black) x 3
- ② Washer
- ③ Spring washer
- ④ Nut
- ⑤ Pin
- ⑥ Rubber cushion (Gray) x 1

Semi-submerged type

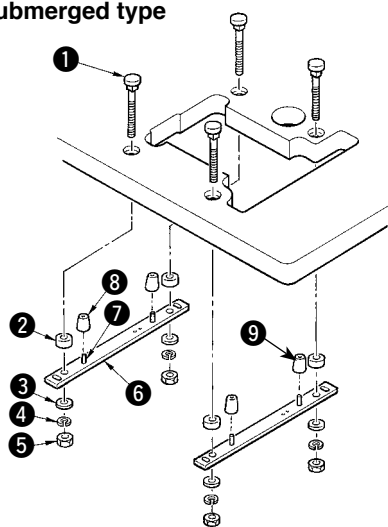

Attach the supporting board and the rubber seats as shown in the illustration and properly install the sewing machine.

- ① Bolt
- ② Spacer
- ③ Washer
- ④ Spring washer
- ⑤ Nut
- ⑥ Supporting board
- ⑦ Spring pin
- ⑧ Rubber cushion (Black) x 3
- ⑨ Rubber cushion (Gray) x 1

■ Installing the rubber cushion

Install the gray dust-proof rubber to section A only.

	Part No.	Part name	Q'ty
①	40072505	Dust-proof rubber (Gray)	1
②	13155403	Dust-proof rubber (Black)	3

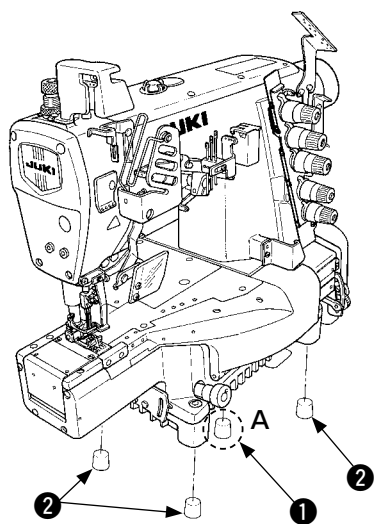

[For the direct-drive type]

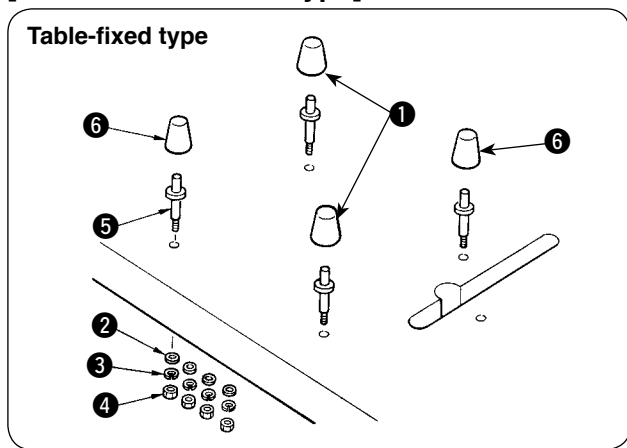

Attach the pins and the rubber cushions as shown in the illustration and properly install the sewing machine.

- ❶ Rubber cushion (Black) x 2
- ❷ Washer
- ❸ Spring washer
- ❹ Nut
- ❺ Pin
- ❻ Rubber cushion (Gray) x 2

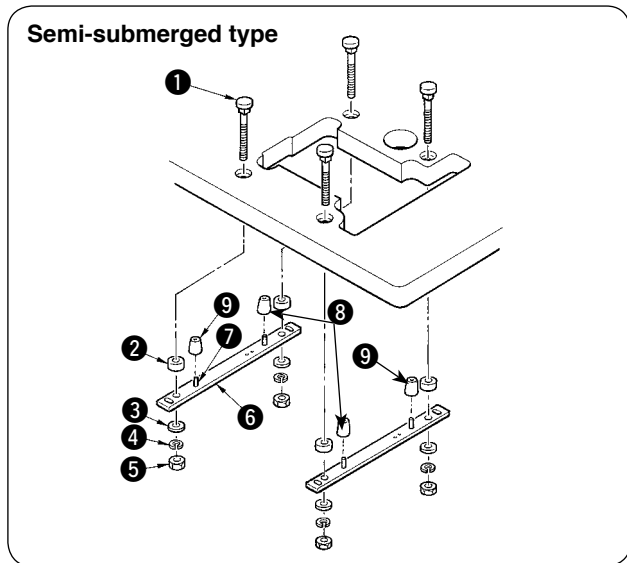

Attach the supporting board and the rubber seats as shown in the illustration and properly install the sewing machine.

- ❶ Bolt
- ❷ Spacer
- ❸ Washer
- ❹ Spring washer
- ❺ Nut
- ❻ Supporting board
- ❼ Spring pin
- ❽ Rubber cushion (Black) x 2
- ❾ Rubber cushion (Gray) x 2

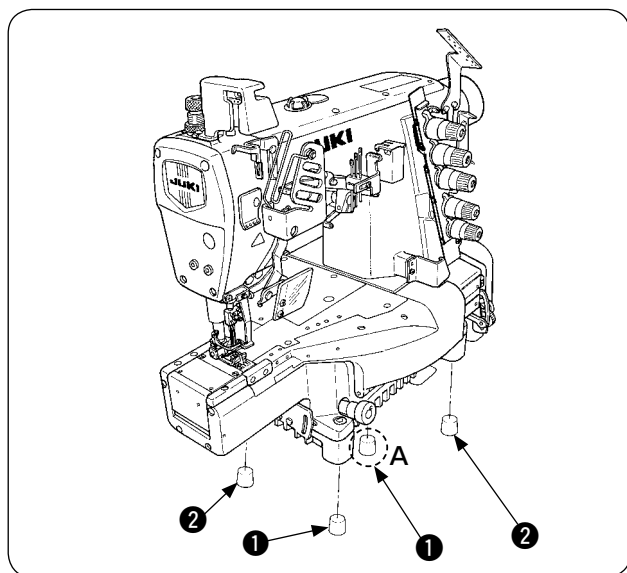

■ Installing the rubber cushion

Install the gray dust-proof rubber to section A only.

	Part No.	Part name	Q'ty
❶	40072505	Dust-proof rubber (Gray)	2
❷	13155403	Dust-proof rubber (Black)	2

① DRAWING OF TABLE (TABLE-FIXED TYPE) V-BELT TYPE

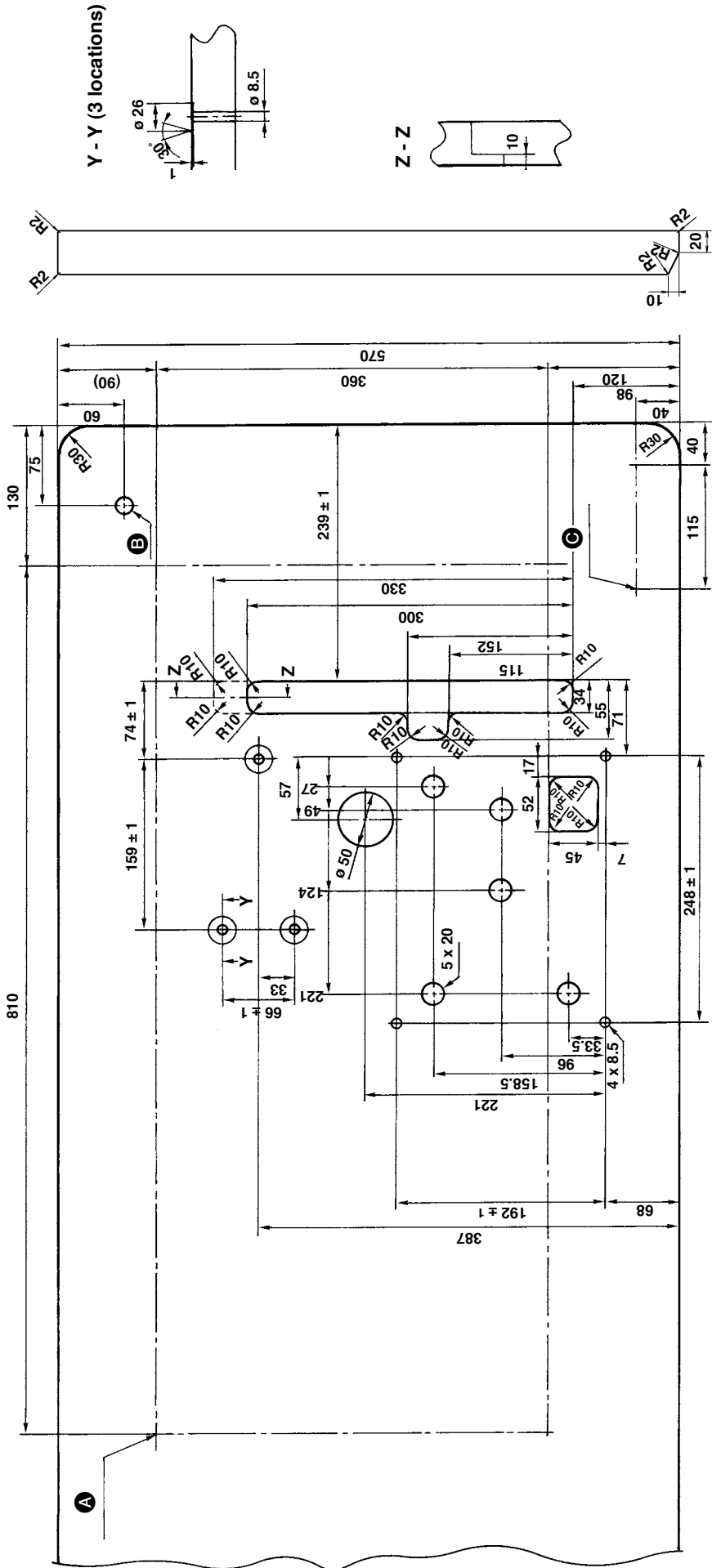

Ⓐ 4- ϕ 3.4 on the bottom surface, depth 20 (Drill a hole at the time of set-up.)

Ⓑ Drilled hole 17

Ⓒ 2- ϕ 3.4 on the bottom surface, depth 10 (Drill a hole at the time of set-up.)

② DRAWING OF TABLE (TABLE-FIXED TYPE) DIRECT-DRIVE TYPE

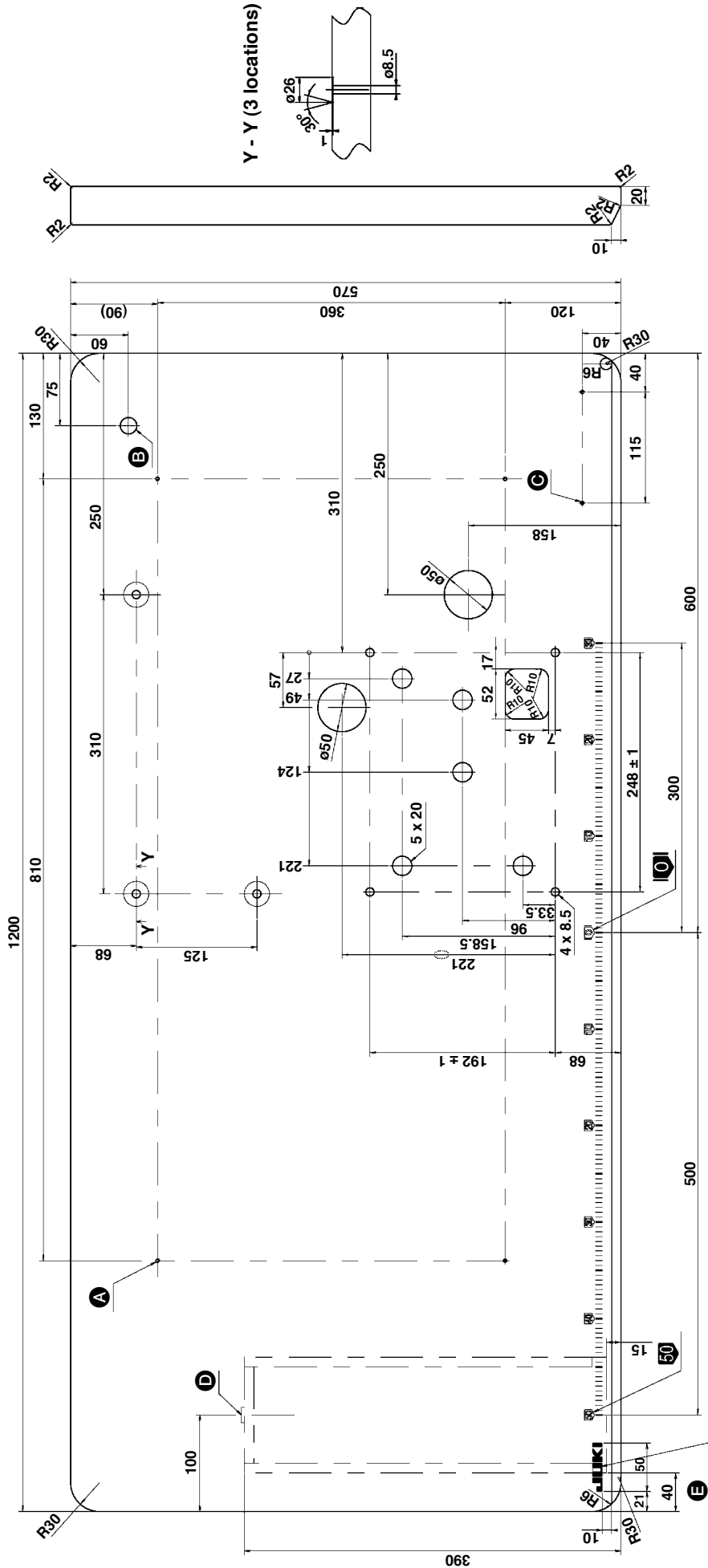

- A 4 - ϕ 3.4 on the bottom surface, depth 20 (Drill a hole at the time of set-up.)
- B Drilled hole 17
- C 2 - ϕ 3.4 on the bottom surface, depth 10 (Drill a hole at the time of set-up.)
- D Installing position of drawer stopper (on the reverse side)
- E JUKI logotype

③ DRAWING OF TABLE (SEMI-SUBMERGED TYPE) V-BELT TYPE

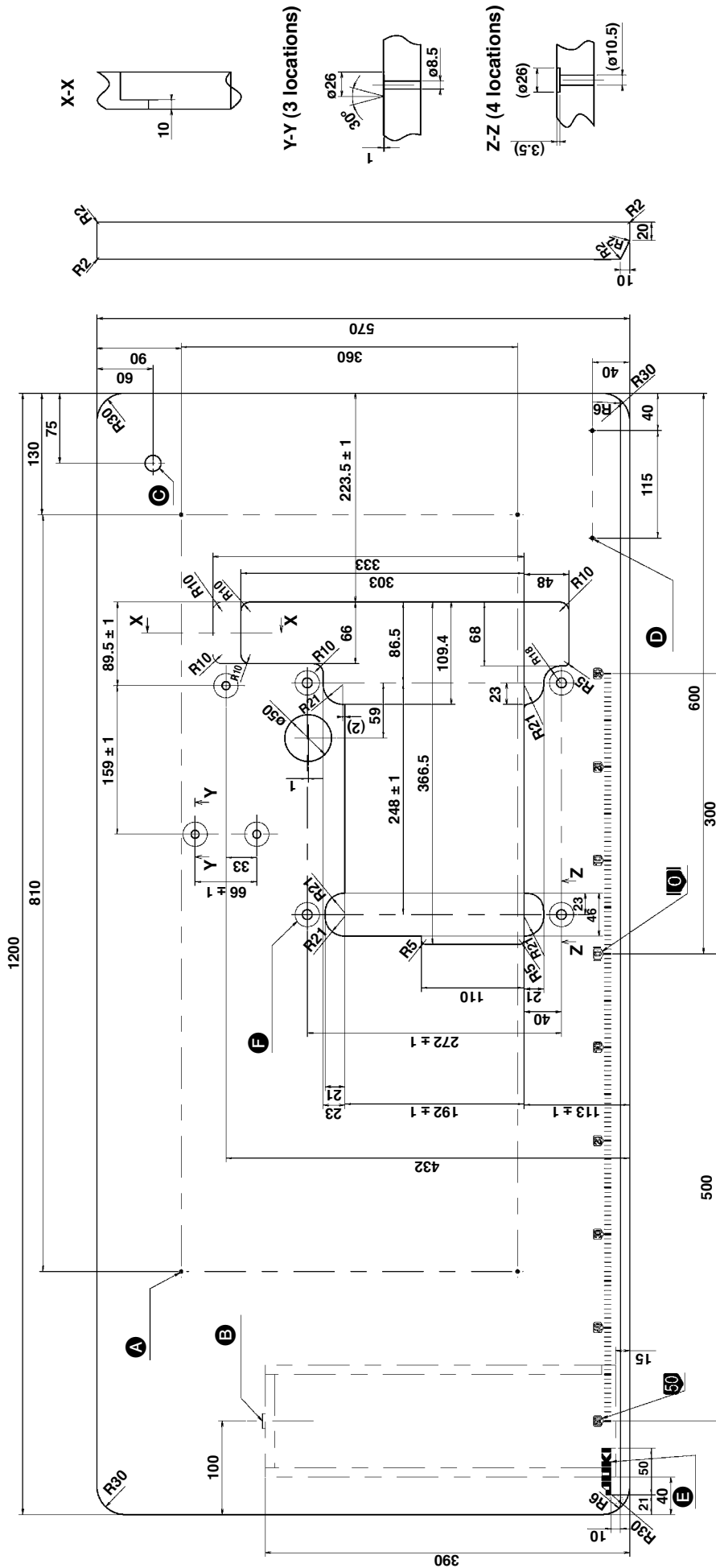

- A** 4 - ϕ 3.4 on the bottom surface, depth 20 (Drill a hole at the time of set-up.)
- B** Installing position of drawer stopper (on the reverse side)
- C** Drilled hole 17
- D** 2 - ϕ 3.4 on the bottom surface, depth 10 (Drill a hole at the time of set-up.)
- E** JUKI logotype
- F** 4 - 10.5 hole, 26 hole facing depth 3.5

2. Selecting the motor pulley and the belt

Motor pulley and belt

Speed of stitch (sti/min)	50Hz		60Hz	
	Pulley size	Belt size	Pulley size	Belt size
4,500	ø 100	M-39	ø 85	M-38
4,800	ø 110	M-40	ø 90	M-38
5,000	ø 115	M-40	ø 95	M-39
5,500	ø 125	M-41	ø 105	M-39
5,800	ø 135	M-42	ø 110	M-40
6,000	ø 140	M-42	ø 115	M-40
6,200	ø 145	M-43	ø 120	M-41
6,500	ø 150	M-43	ø 125	M-41



When you use a new sewing machine, use the machine at a speed of 4,500 sti/min or less for the first 200 hours (approximately one month). A good result can be obtained in terms of the durability.

* The table shows the numbers when a 3-phase 2-pole 400 W clutch motor (1 / 2 HP) is used.

* The commercially-available motor pulley near to the counted value is designated since the outside diameter of the commercially-available motor pulley counts by 5 mm.



Use a motor pulley which is adaptable to this sewing machine. The sewing speed exceeds the max. sewing speed of this sewing machine and machine trouble will be caused unless a motor pulley which is adaptable to this sewing machine is used.

3. Installing the motor

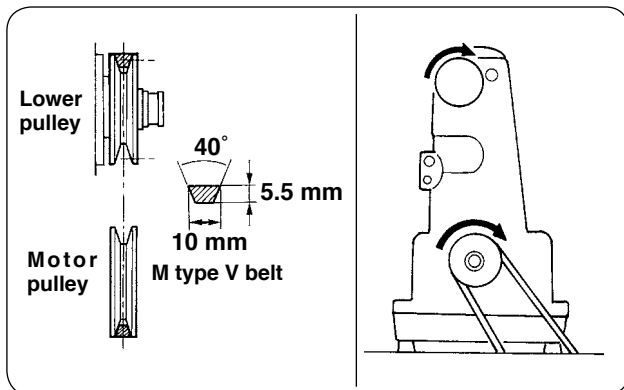

Use a clutch motor of 3-phase, 2-pole, 400 W (1/2HP). Use the M type V belt.

1) The motor pulley shifts to the left-hand side when depressing the pedal. At this time, install the motor so that the centers of motor pulley and lower pulley align with each other.

* For the installing procedure of the motor pulley, refer to the Instruction Manual for motor.

2) Install the motor so that the pulley rotates clockwise.



If the machine pulley rotates in the reverse direction, normal lubrication cannot be performed. As a result, machine trouble will be caused.

4. Setting the belt



WARNING :

When replacing the belt, be sure to turn OFF the power to the motor and ascertain that the motor has totally stopped rotating before starting the work. There is a danger of injury since hands or clothes may be caught in the belt.

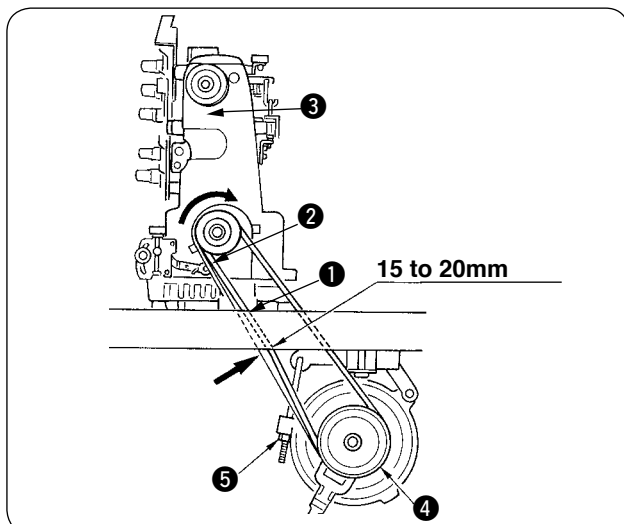

1) Fit belt ① to lower pulley ②.

2) Turning upper pulley ③, set the other side of the belt to motor pulley ④.

3) Adjust the belt tension so that the belt sags 15 to 20 mm when the center of the belt is pressed with an approximate 10N (1.02 kgf) load.

4) Securely fix the belt with lock nut ⑤ when the belt has been set.



If the deflection of the belt is excessive when the sewing machine is operated, check again the belt tension.

5. Installing the belt cover



WARNING :

Be sure to install the belt cover. If it is not installed, there is a danger of injury since hands or clothes may be caught in the machine or a danger of damage of the machine since sewing products may be caught in the machine.

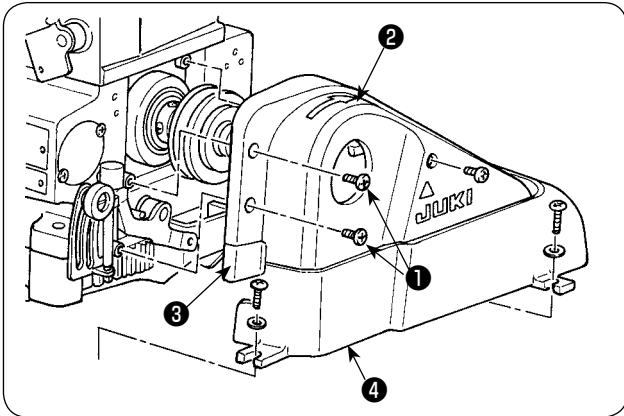

Install belt cover **2** as shown in the illustration.

The setscrews **1** are the fixation screws of belt cover **2**.

* When installing the belt cover, use the cover with part **3** cut out.

* When the semi-submerged type table is used with the machine, cover **4** is not used.

6. Installing the chain

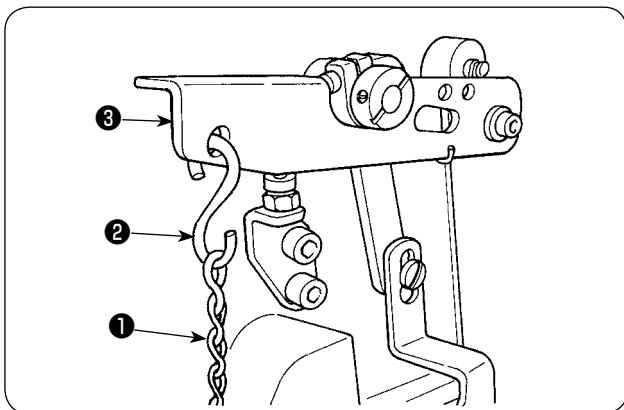

1) Hang hook **2** of chain **1** to presser bar lifting lever **3**.

2) Hook the other side of the chain **1** to the pedal.

7. Installing the thread guide

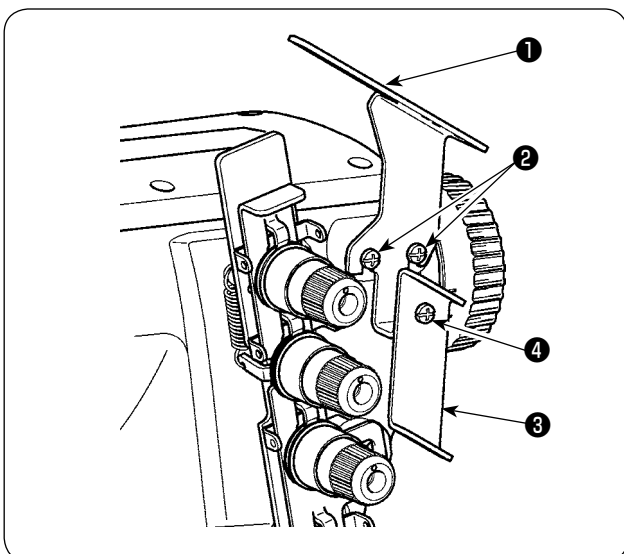

1) Install thread guide No. 1 **1** supplied as accessories on the machine arm with screws (black, screw shank length 6 mm) **2**.

2) Install thread guide **3** on thread guide No. 1 **1** with screw (black, screw shank length 6 mm) **4**.

8. Installing the needle bar thread take-up cover

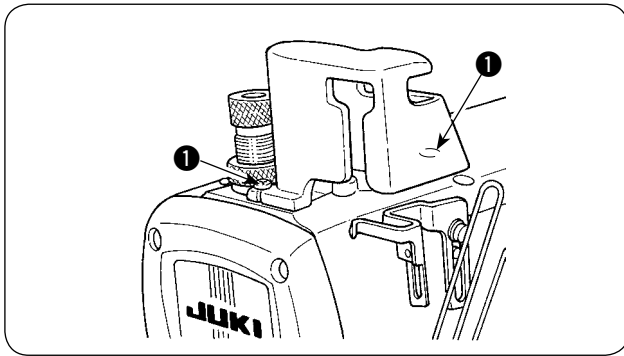

Install the needle bar thread take-up cover supplied with the unit on the machine arm with two screws ①.

IV. LUBRICATION AND OILING

1. Lubricating oil

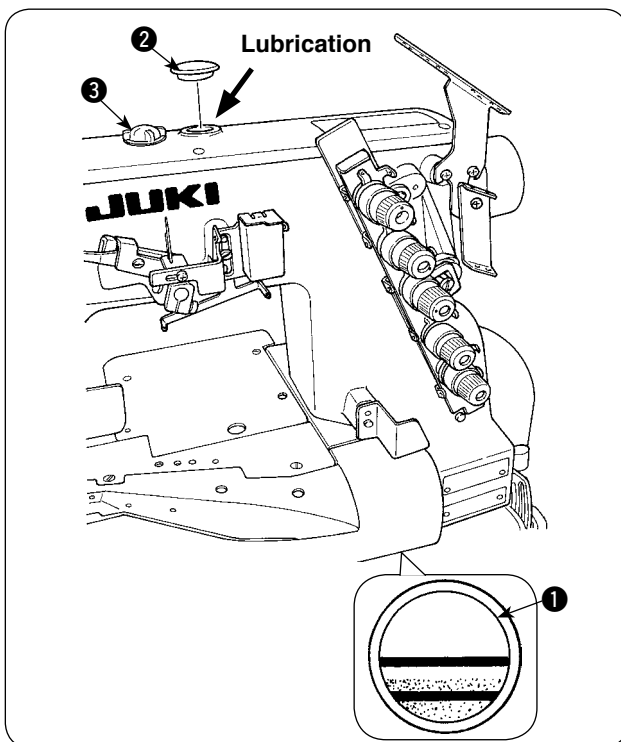

<When using the sewing machine for the first time>

Lubricating oil has been taken out at the time of delivery. Be sure to supply lubricating oil before using the sewing machine for the first time.

• Oil used : JUKI GENUINE OIL 18

Caution Do not use oil addition agent since deterioration of lubricating oil or machine trouble will be caused.

Remove oil hole cap ② on which "OIL" is indicated and fill the oil reservoir with lubricating oil up to the level between the upper and lower engraved marker lines.

<Checking before using the sewing machine>

- 1) Check oil gauge ① and make sure that lubricating oil level is between the upper and lower two lines. When lubricating oil level lowers below the lower line, supply lubricating oil.
- 2) Make sure that lubricating oil comes out from the nozzle of oil circulation identification window ③ when rotating the sewing machine. When lubricating oil does not come out, perform "[VII-3. Inspecting and replacing the oil filter](#)" p.28.

2. Oiling



WARNING :

To protect against possible personal injury due to abrupt start of the machine, be sure to start the following work after turning the power off and ascertaining that the motor is at rest.

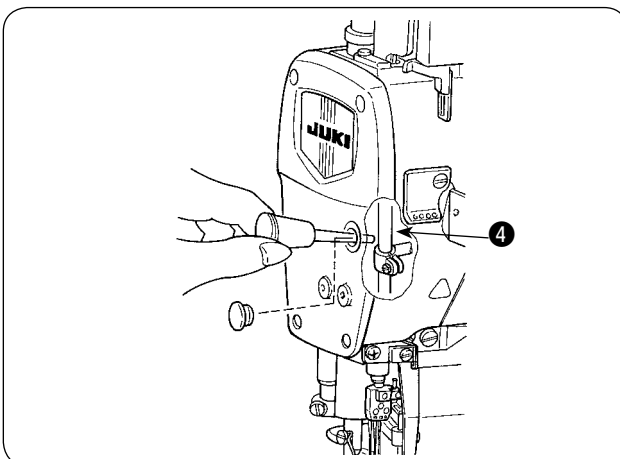

When you operate the sewing machine for the first time or after an extended period of disuse, be sure to apply 2 to 3 drops of lubricating oil to needle bar ④.

For the lubricating oil, use JUKI GENUINE OIL 18.

3. Silicon oil lubricating unit

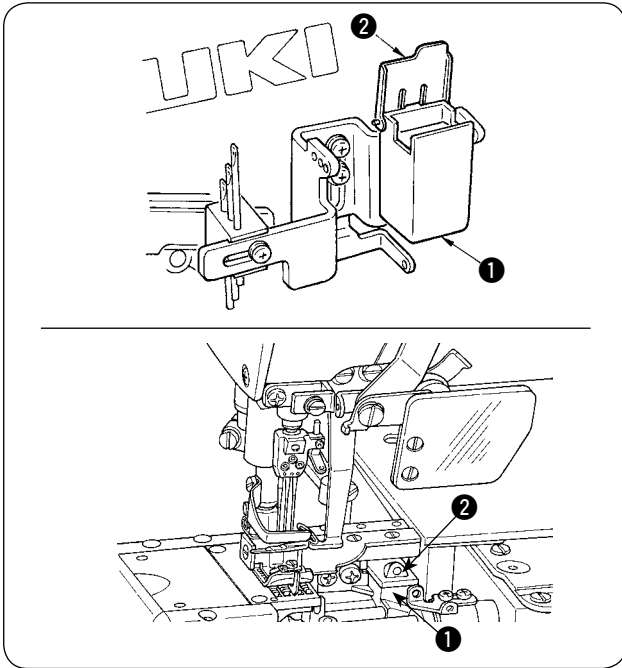

This sewing machine is provided with the silicon oil lubricating unit as standard. In case of sewing at a high speed, or using chemical thread or chemical fabric, use the silicon oil lubricating unit to prevent thread breakage or stitch skipping.

Oil used is silicon oil (dimethyl silicon).

Open cover 2 of silicon container 1 and make sure that silicon oil enters needle thread, needle tip and silicon oil lubricating unit. If silicon oil is insufficient there, supply it (dimethyl silicon).

When silicon oil adhered to the components other than the silicon oil lubricating unit, be sure to wipe it out. If the components to which silicon oil adhered are kept without wiping out the oil, sewing machine trouble will be caused.



V. OPERATION

1. Needle

Japan No.	9	10	11	12	14
German No.	65	70	75	80	90

The needle used for this sewing machine is UY128GAS.

For the needle No., select a proper needle in accordance with the sewing conditions.

2. Attaching the needle



WARNING :

To protect against possible personal injury due to abrupt start of the machine, be sure to start the following work after turning the power off and ascertaining that the motor is at rest.

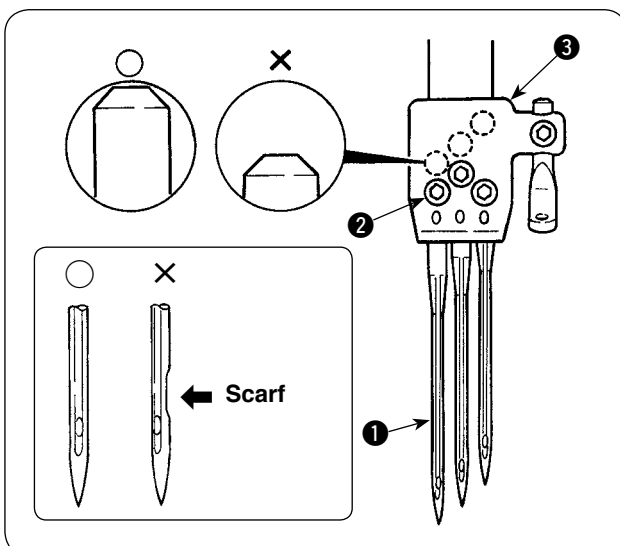

- 1) Loosen setscrew 2 of needle 1 with a screwdriver.
- 2) Hold the new needle with indented part facing to the rear and insert it into the hole in needle clamp 3 until the end of hole is reached.
- 3) Securely tighten setscrew 2 of the needle.

3. Threading the machine head



WARNING :

To protect against possible personal injury due to abrupt start of the machine, be sure to start the following work after turning the power off and ascertaining that the motor is at rest. If threading is wrong, stitch skipping, thread breakage, needle breakage or irregular stitches will be caused. So, be careful.

(1) Standard threading

Thread the machine head according to the following threading illustrations.

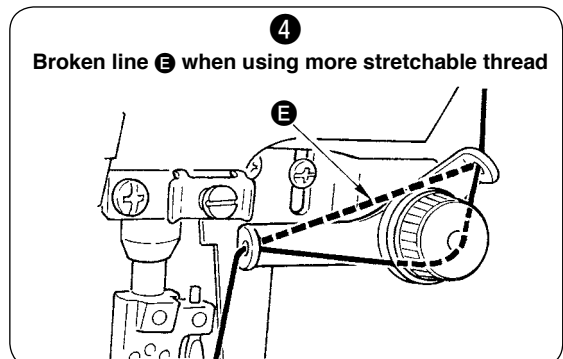
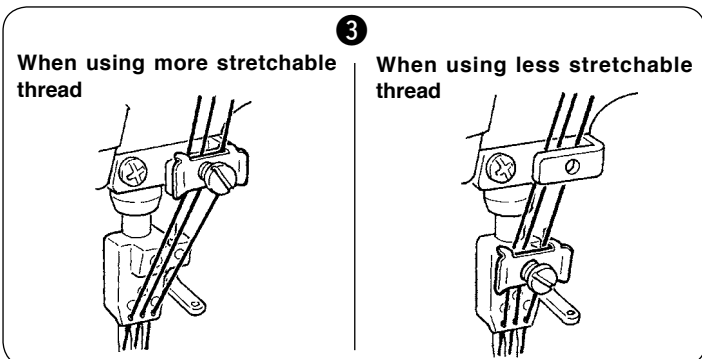
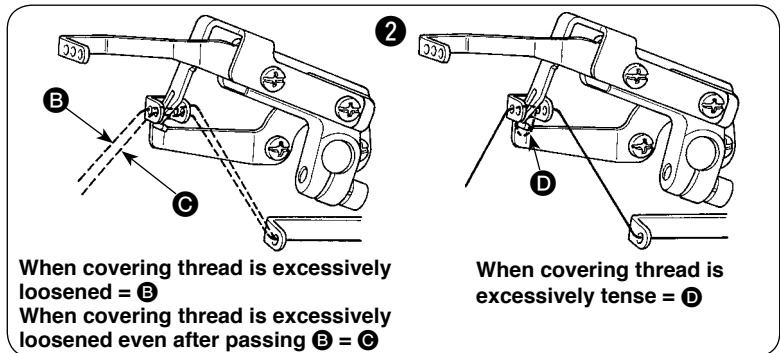
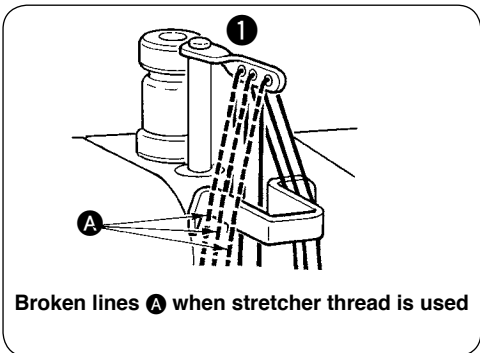
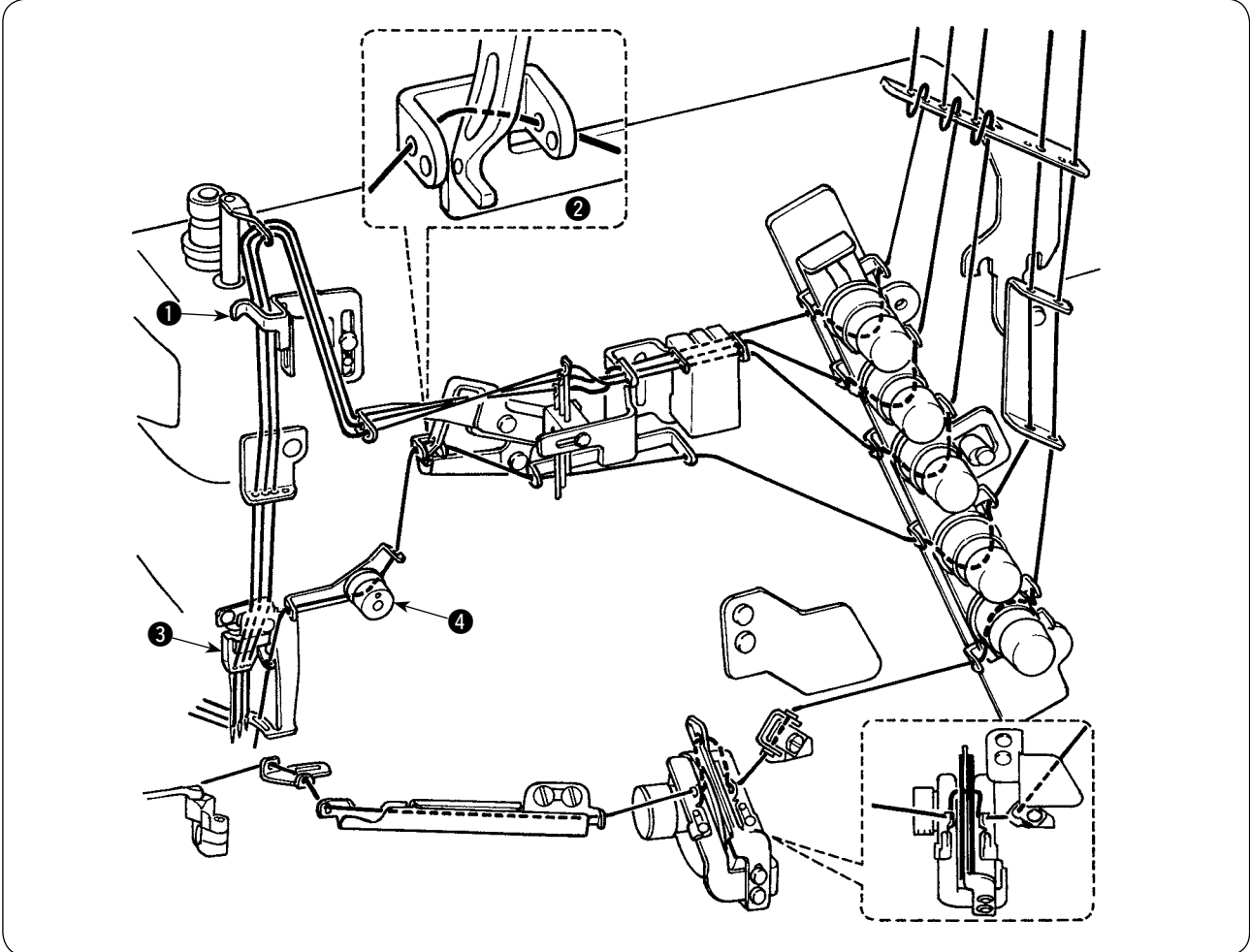

4. Adjusting the stitch length



WARNING :

To protect against possible personal injury due to abrupt start of the machine, be sure to start the following work after turning the power off and ascertaining that the motor is at rest.

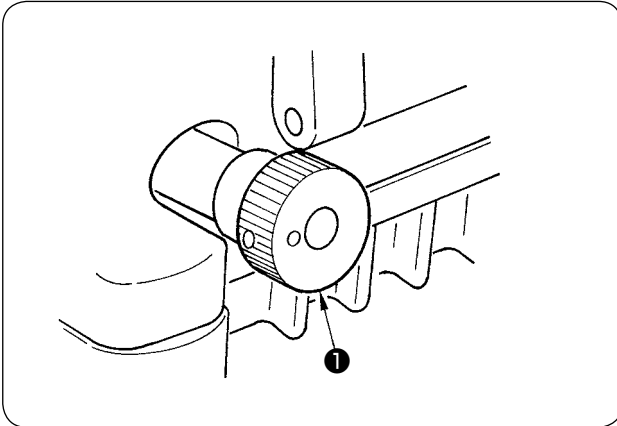

The stitch length can be infinitely adjusted from 0.9 mm to 3.6 mm.

* The actually sewn stitch length varies in accordance with kind and thickness of the materials.

[How to change the stitch length]

Turn clockwise feed regulating knob ① to increase the stitch length.

Turn it counterclockwise to decrease the stitch length.

• **When making the stitch length 3.6 mm or more**
Loosen screw ② and turn clockwise feed regulating knob ① to regulate the stitch length.

Push pin ③ until it goes to the end, and fix it with screw ②. Use the machine within the range where feed dogs or feed dog and throat plate do not come in contact with each other.

5. Adjusting the differential feed ratio

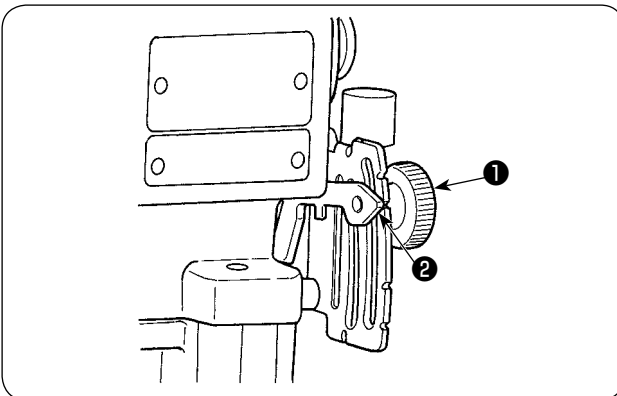

Loosen differential lock nut ① and move lever ② up to increase the differential feed ratio. Then the sewn material is gathered. Move lever ② down to decrease the differential feed ratio. Then the sewn material is stretched.

Fine adjustment of the differential feed ratio can be performed with micro-adjustment knob ③.

[When setting the differential feed ratio to 1 : 0.6 to 1 : 0.9]

Remove setscrew ④ in differential feed link ⑤.

Tighten differential feed link ⑤ to screw hole ⑥ with setscrew ④ which has been removed.

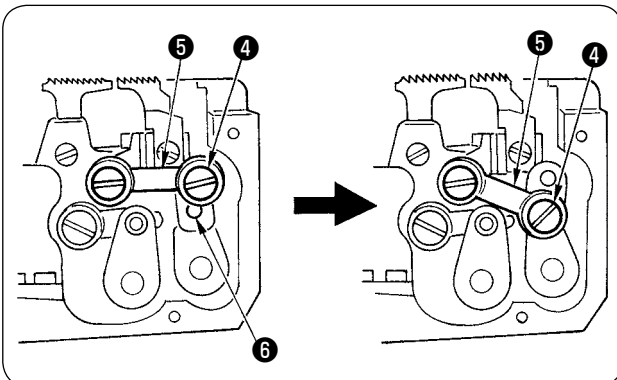

Caution
There is a case where feed dogs or feed dog and throat plate come in contact with each other by the aforementioned adjustment according to the relation between the stitch length and the differential feed ratio. So, be very careful.

The differential feed ratio can be changed from A to B by changing the position of differential feed link ⑤ to screw hole ⑥ with setscrew ④.

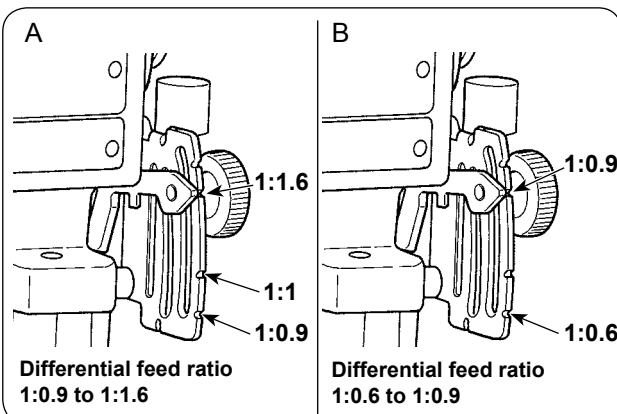

6. Adjusting the presser foot pressure

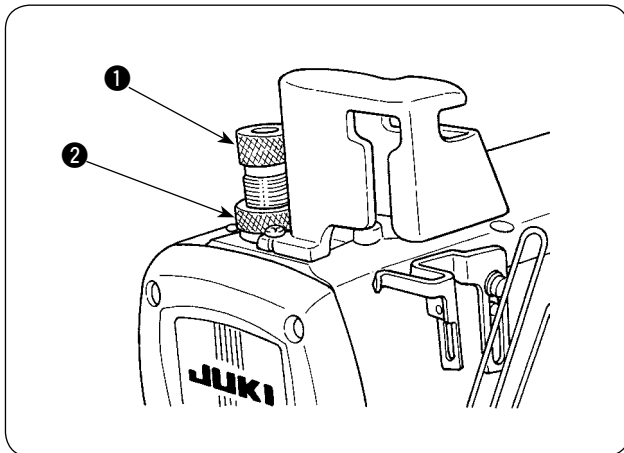

Decrease the presser foot pressure as low as possible to such an extent that stitches are stabilized.

To adjust the pressure, loosen lock nut **2** of presser spring regulator **1** and turn presser spring regulator **1**.

After the adjustment, tighten lock nut **2**.

Turning it clockwise to increase the pressure.

Turning it counterclockwise to decrease the pressure.

7. Adjusting the thread tension

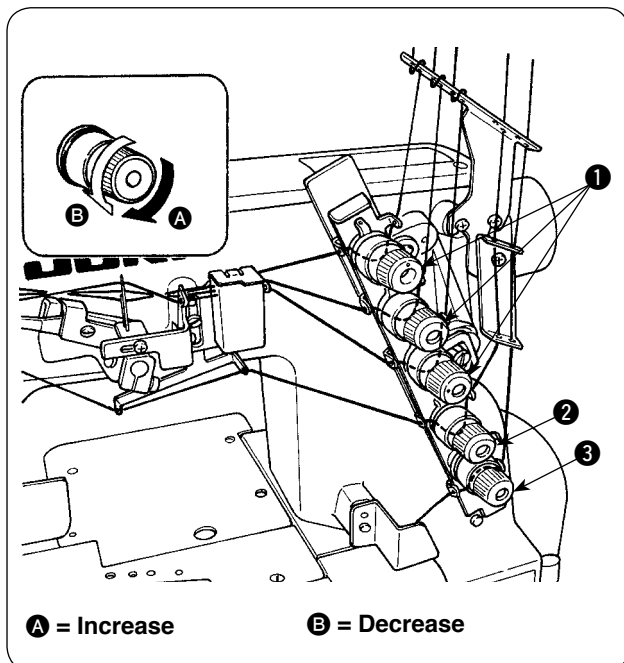

Adjust the thread tension with the following thread tension nuts.

1 Needle thread tension nut

2 Top covering thread tension nut

3 Looper thread tension nut

Turn clockwise to increase the thread tension.

Turn counterclockwise to decrease the thread tension.

VI. ADJUSTING THE SEWING MACHINE

1. Adjusting the silicon container thread guide



WARNING :

To protect against possible personal injury due to abrupt start of the machine, be sure to start the following work after turning the power off and ascertaining that the motor is at rest.

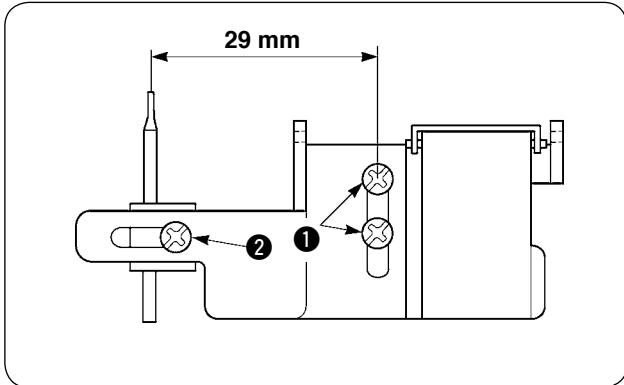

- 1) Loosen setscrews ❶. Fix setscrews ❶ with shifted to the lowermost position.
- 2) Loosen setscrew ❷. Adjust so that the center of screw is spaced 29 mm away from the center of the needle thread guide rod. Then, fix setscrew ❷.

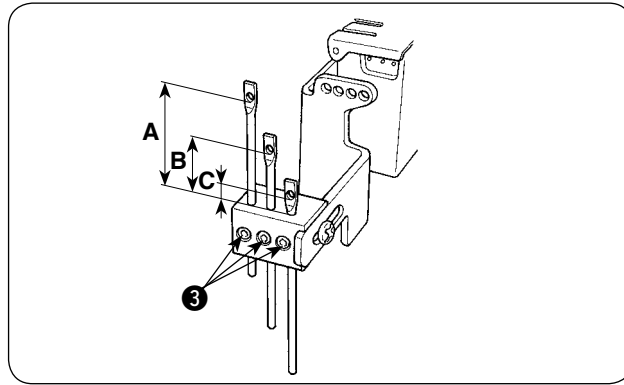

A	B	C
29 mm	17 mm	5 mm

- 3) Loosen setscrews ❸ and adjust so that the heights of the respective needle thread guide rods are the dimensions as shown in the table. Then tighten screws ❸ to fix the thread guide rods.

2. Adjusting the needle bar thread take-up thread receiver



WARNING :

To protect against possible personal injury due to abrupt start of the machine, be sure to start the following work after turning the power off and ascertaining that the motor is at rest.

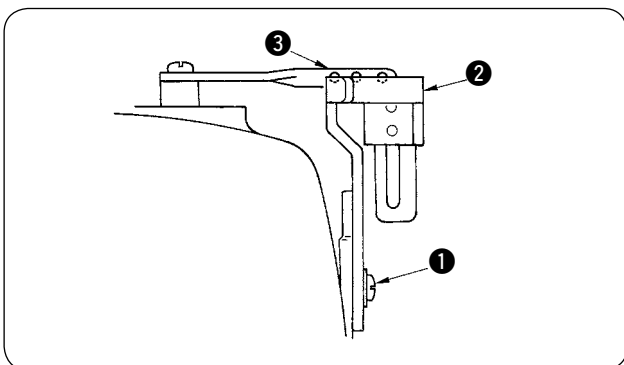

Loosen setscrew ❶ and adjust so that the bottom end to the center of the thread hole of needle bar thread take-up ❸ aligns with the top end of needle bar thread take-up thread receiver ❷ when the needle bar is in its lowest position. Then tighten screw ❶ to fix the needle bar thread take-up thread receiver.

3. Adjusting the rocking thread take-up



WARNING :

To protect against possible personal injury due to abrupt start of the machine, be sure to start the following work after turning the power off and ascertaining that the motor is at rest.

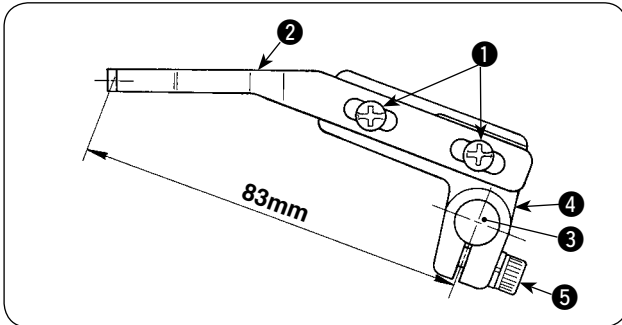

- 1) Loosen setscrew **1**. Move rocking thread take-up **2** to right and left to adjust the distance between the thread hole and the center of rocking thread take-up shaft **3** to 83 mm. Fix setscrew **1**.
- 2) Adjust so that rocking thread take-up base **4** is level when the rocking thread take-up is in its lowest position. Retighten screw **5** to fix the rocking thread take-up base.

4. Adjusting the spreader thread guide



WARNING :

To protect against possible personal injury due to abrupt start of the machine, be sure to start the following work after turning the power off and ascertaining that the motor is at rest.

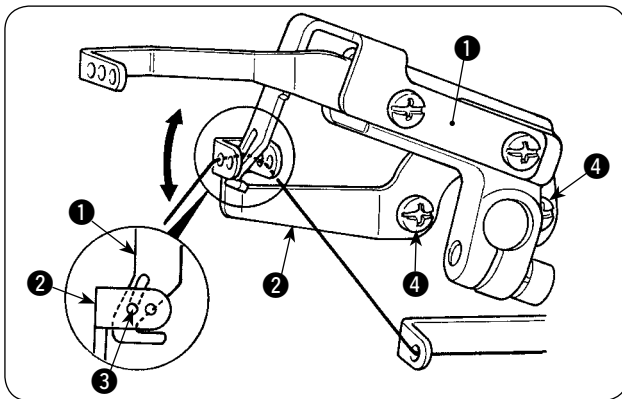

Adjust so that the top end of thread guide thread path (rear) **3** of spreader thread guide **2** aligns with the lowest position of slot of spreader thread take-up **1** when spreader thread take-up **1** is in its highest position. Then tighten screw **4** to fix the spreader thread guide.

5. Adjusting the looper thread cam thread guide and the looper thread cam



WARNING :

To protect against possible personal injury due to abrupt start of the machine, be sure to start the following work after turning the power off and ascertaining that the motor is at rest.

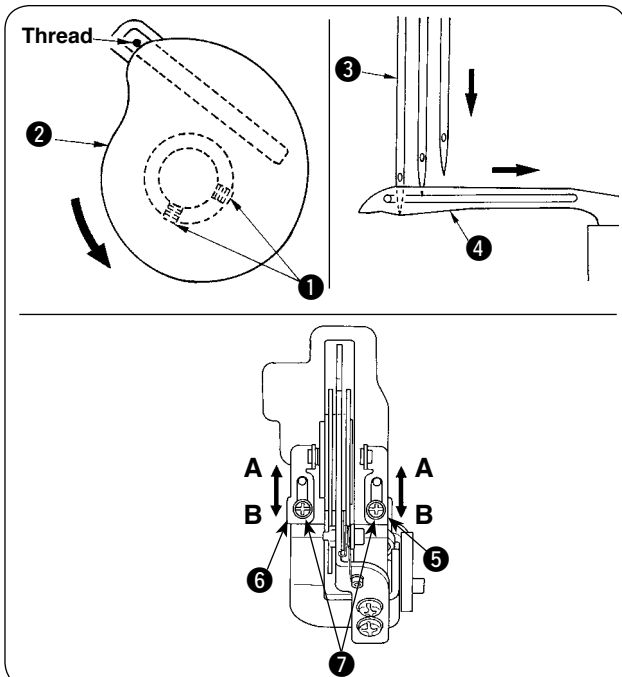

[Adjusting the looper thread cam]

Adjust so that thread comes off from the highest place of looper thread cam **2** when needles come down and the top end of left needle **3** aligns with the bottom surface of looper **4**. Then tighten screws **1** to fix the looper thread cam.

[Adjusting the looper thread cam thread guide]

When the thread drawing amount is desired to be decreased in case of 2-needle machine or the like, loosen screws **7**, move upward thread guides **5** and **6** and tighten screws **7** to fix them.

A = Decrease B = Increase

6. Adjusting the looper



WARNING :

To protect against possible personal injury due to abrupt start of the machine, be sure to start the following work after turning the power off and ascertaining that the motor is at rest.

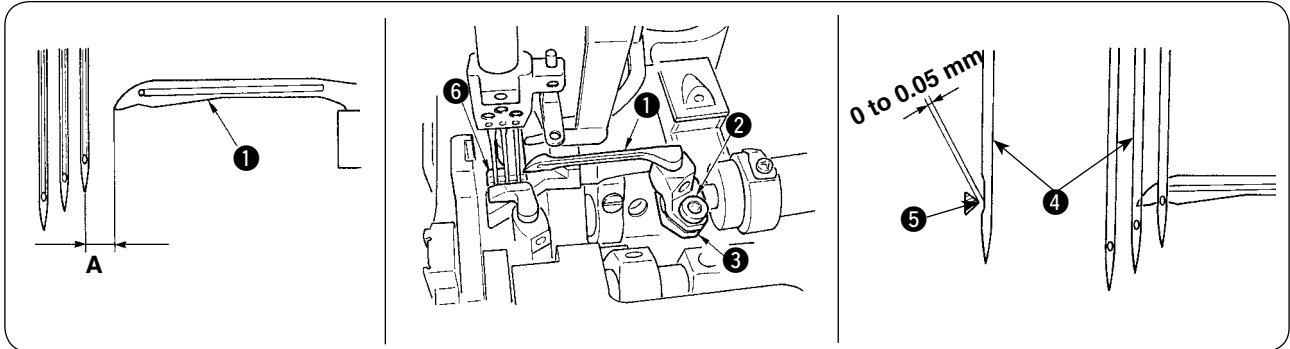

[Lateral position]

The relation between clearance **A** between looper **1** and the center of right-hand needle and the needle gauge is as shown in the table.

Unit : mm

2-needle		3-needle	
Needle gauge	Return amount A	Needle gauge	Return amount A
3.2	4.3		
4.0	3.9		
4.8	3.5		
5.6	3.1	5.6	3.1
6.4	2.7	6.4	2.7

Loosen clamp screw **2** and laterally adjust looper holder **3** in accordance with the table.

[Longitudinal position]

Adjust so that the clearance between blade point **5** of the looper and medium needle **4** is 0 to 0.05 mm when the top end of the looper comes from the extreme right position to the center of the medium needle. After the adjustment, tighten clamp screw **2** to fix the looper.

* The blade point of the looper comes in contact with the right-hand needle when rear needle guard **6** does not work. So, be careful.

7. Adjusting the height of the needle



WARNING :

To protect against possible personal injury due to abrupt start of the machine, be sure to start the following work after turning the power off and ascertaining that the motor is at rest.

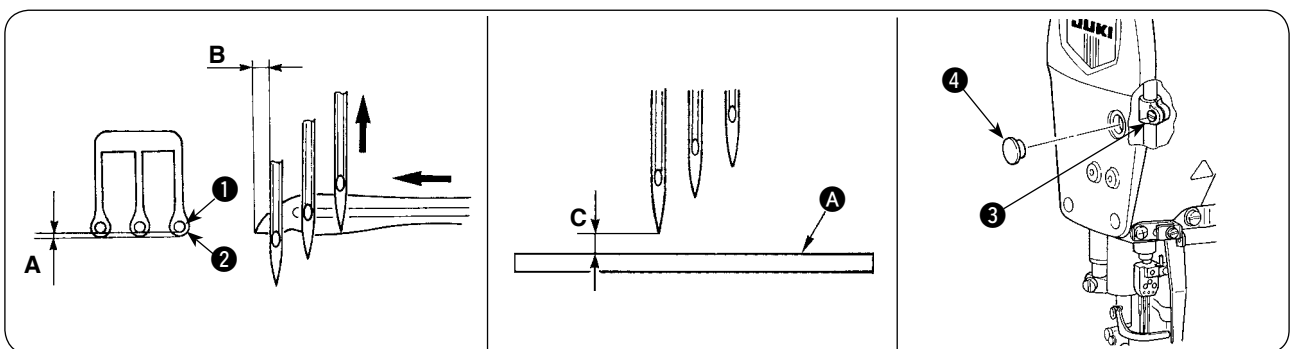

- 1) Equally adjust clearance **A** between needles **1** and needle holes **2** in the throat plate.
- 2) Adjust the needle bar height so that the top end of the left-hand needle eyelet aligns with the bottom end of looper when the looper travels from the extreme right position to the left until the top end **B** of the looper protrudes from the left end of the left-hand needle by approximately 1 to 1.2 mm. Then, remove rubber cap **4** from the face plate, and tighten needle bar connection setscrew **3**.

Reference : Height from the top surface of the throat plate **A** to the top end of left-hand needle, **C** when the needle is in the higher dead point is as shown in the table.

Unit : mm

2-needle		3-needle	
Needle gauge	Height of left-hand needle, C	Needle gauge	Height of left-hand needle, C
3.2	8.9		
4.0	8.6		
4.8	8.1		
5.6	7.8	5.6	7.8
6.4	7.3	6.4	7.3

8. Adjusting the rear needle guard



WARNING :

To protect against possible personal injury due to abrupt start of the machine, be sure to start the following work after turning the power off and ascertaining that the motor is at rest.

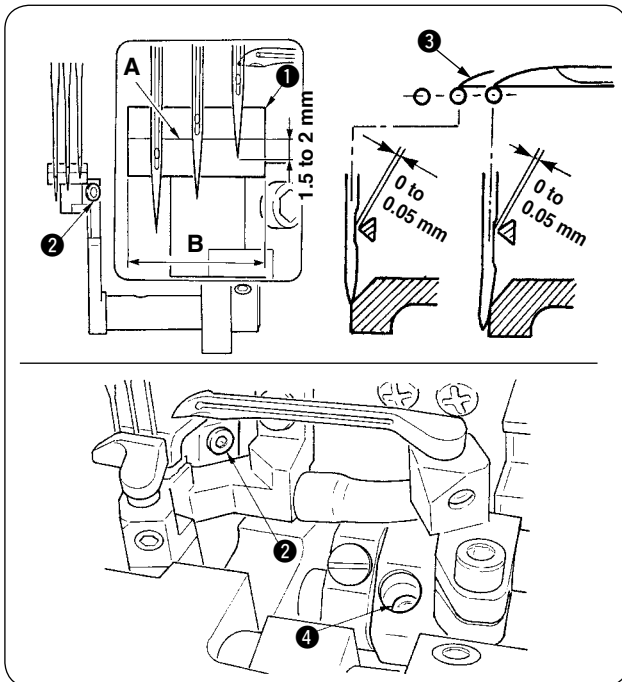

Adjust the lateral position of rear needle guard ① so that it receives the needle within the range of B when the needle is in its lowest position.

- 1) Adjust the height with setscrew ② so that the distance from edge line A of rear needle guard ① to the top end of right-hand needle is 1.5 to 2 mm when the top end ③ of the looper comes from the extreme right end to the center of right-hand needle.
- 2) Make rear needle guard ① slightly come in contact with the right-hand needle so that the clearance between right-hand needle and top end ③ of the looper is 0 to 0.05 mm when top end ③ of the looper comes from the extreme right end to the center of right-hand needle.

In addition, make rear needle guard ① slightly come in contact with the medium needle so that the clearance between the medium needle and top end ③ of the looper keeps 0 to 0.05 mm when top end ③ of the looper comes to the center of medium needle. Perform the adjustment with setscrews ② and ④.

9. Relation between the rocking thread take-up timing and the needle thread loop



WARNING :

To protect against possible personal injury due to abrupt start of the machine, be sure to start the following work after turning the power off and ascertaining that the motor is at rest.

In the case stitch skipping or thread breakage occurs because the needle thread loop is too large or too small, change the needle thread feeding timing of the rocking thread take-up to adjust the size of the needle thread loop.

(1) Adjustment by the crank

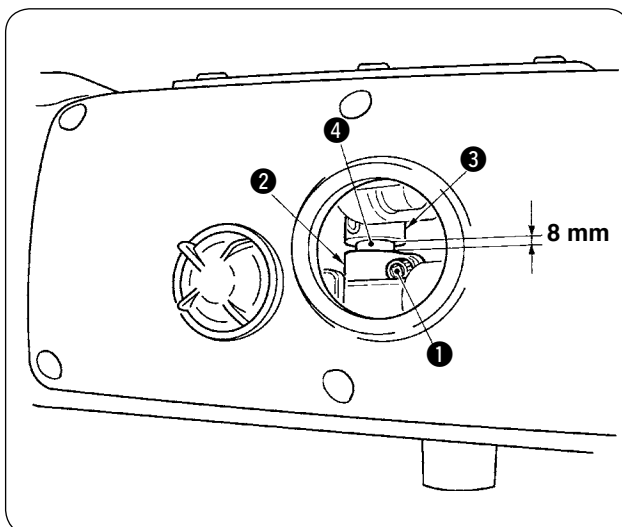

- 1) Loosen screw ①.
 - 2) Move ② forward or backward. The relation between the moving direction and the size of needle thread loop is as shown in the table below.
 - 3) After the adjustment, securely tighten screw ①.
- * Clearance between crank ② and thrust collar ③ has been factory-adjusted to 8 mm at the time of delivery. (Engraved marker line on rocking thread take-up shaft ④ aligns with the edge of crank ②.)

• Size of needle thread loop

Move forward	Move backward
Loop becomes smaller.	Loop becomes larger.



1. When screw ① is loosened, the rocking thread take-up rotates due to the light weight. So, be careful. If it rotates, refer to the item "[VI-3.Adjusting the rocking thread take-up](#)" p.17.
2. Do not change the timing other than the aforementioned one since the sewing trouble will be caused.

(2) Adjustment by the eccentric cam

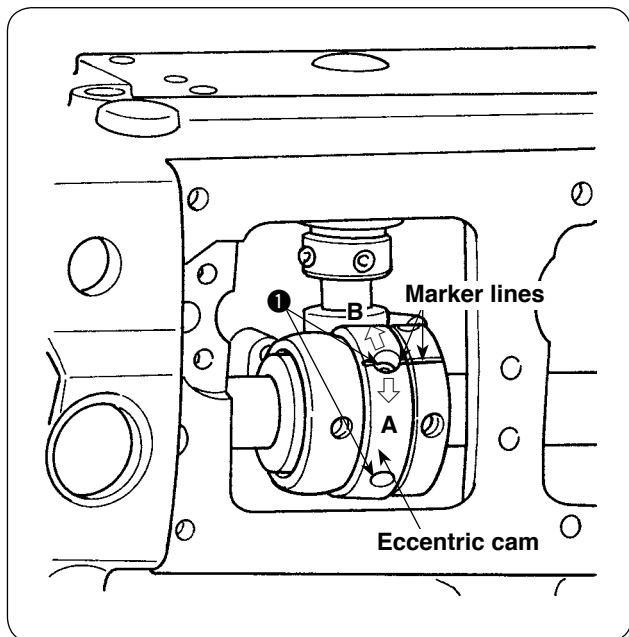

- 1) Remove the top cover.
 - 2) Loosen screw **1**.
 - 3) Turn the eccentric cam. The direction of turning the eccentric cam and the relation between the eccentric cam and the needle thread loop is shown in the following table.
 - 4) After the adjustment, fully tighten screw **1**.
- * With the factory-adjusted value at the time of shipment, the marker lines are aligned.

- Size of needle thread loop

A Move forward	B Move backward
Loop becomes smaller	Loop becomes larger

10. Adjusting the height of the feed dog



WARNING :

To protect against possible personal injury due to abrupt start of the machine, be sure to start the following work after turning the power off and ascertaining that the motor is at rest.

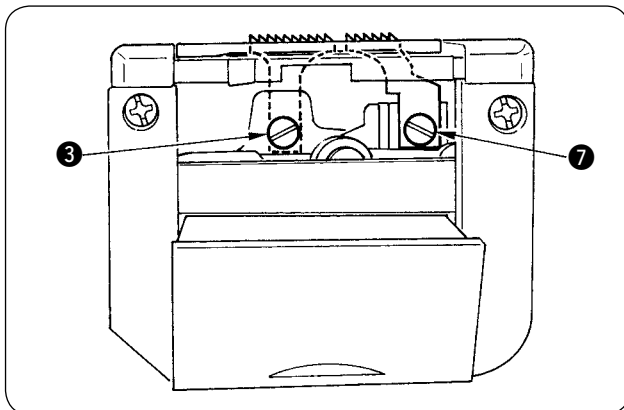

Adjust the height from the top surface of throat plate **1** to the rear end of main feed dog **2** to 1 mm when the feed dog comes to its highest position and tighten setscrew **3** to fix the feed dog.

For the height of differential feed dog **4**, adjust the height of front end **5** of main feed dog **2** to that of rear end **6** of differential feed dog **4**, and tighten set-screw **7** to fix the differential feed dog.

It is the standard that throat plate **1** is flush with the feed dog when the feed dog is in its highest position.

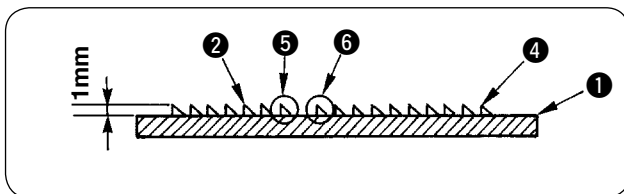

11. Installing position of the spreader



WARNING :

To protect against possible personal injury due to abrupt start of the machine, be sure to start the following work after turning the power off and ascertaining that the motor is at rest.

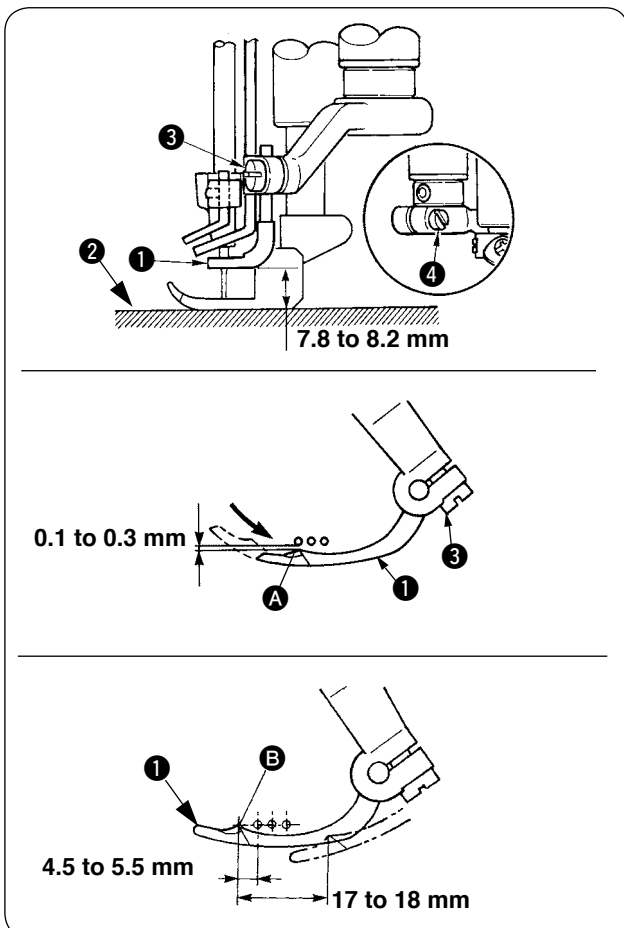

[Adjusting the height]

The height of spreader **1** is 7.8 to 8.2 mm from the top surface of throat plate **2** to the bottom surface of the spreader.

Adjust the height with clamp screw **3** and fix the spreader.

[Adjusting the longitudinal position]

Adjust so that the clearance between the spreader and left-hand needle is 0.1 to 0.3 mm when spreader **1** travels from the extreme left position to the right and section **A** comes to the front of left-hand needle. Then fix the spreader with clamp screw **3**.

[Adjusting the lateral position]

Adjust so that the distance from the center of left-hand needle to section **B** of the spreader **1** is 4.5 to 5.5 mm when the spreader **1** is in the extreme left position. Then fix the spreader with clamp screw **4**.

12. Adjusting the spreader thread guide and the needle clamp thread guide



WARNING :

To protect against possible personal injury due to abrupt start of the machine, be sure to start the following work after turning the power off and ascertaining that the motor is at rest.

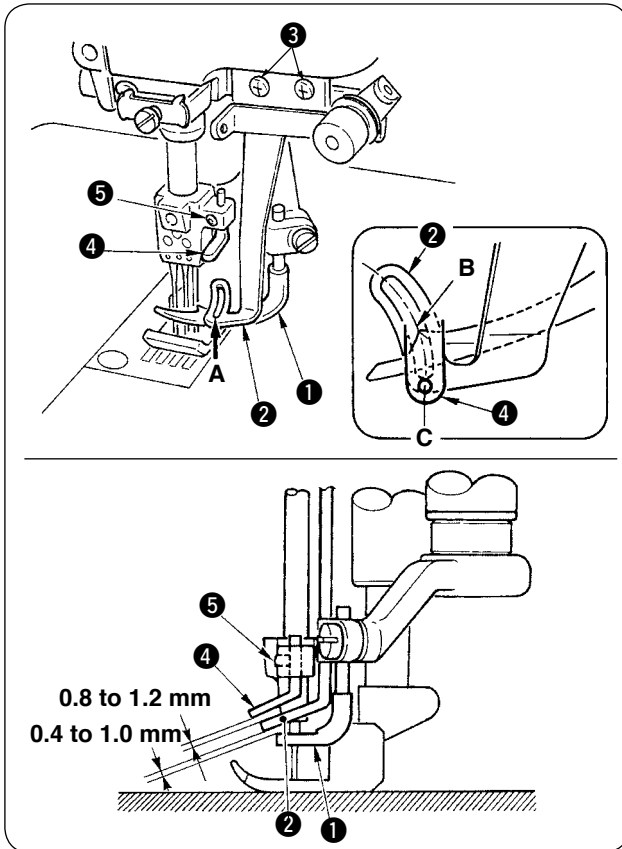

[Spreader thread guide]

Adjust so that the clearance between spreader thread guide ② and spreader ① is 0.4 to 1.0 mm. Then fix the spreader thread guide with setscrews ③.

* Adjust so that the center of slot A of spreader thread guide ② aligns with blade point B of spreader ① when spreader ① is in the extreme right position. In addition, allow the spreader thread guide ② to come near the needle clamp to such an extent that the spreader thread guide does not interfere with the needle clamp.

[Needle clamp thread guide]

Adjust so that the center of thread hole of needle clamp thread guide ④ aligns with center C of slot A when the needle is in the lowest position.

* At this time, adjust so that the clearance between needle clamp thread guide ④ and spreader thread guide ② is 0.8 to 1.2 mm. Then fix the needle clamp thread guide with setscrew ⑤.

13. Adjusting the front needle guard



WARNING :

To protect against possible personal injury due to abrupt start of the machine, be sure to start the following work after turning the power off and ascertaining that the motor is at rest.

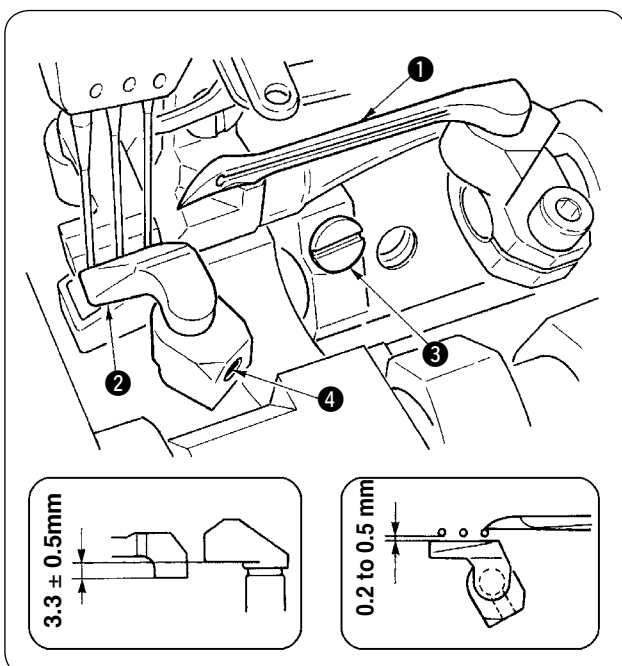

Adjust the height of front needle guard ② with setscrew ④ so that it is higher by 3.3 ± 0.5 mm than the rear needle guard.

Adjust with setscrew ③ so that the clearance between the needle and front needle guard ② is 0.2 to 0.5 mm when looper ① travels from the extreme right position to the left and passes the rear side of the respective needles.

* Allow front needle guard ② to come to the needle as near as possible within the range where needle thread smoothly passes in accordance with the kind or thickness of thread.

14. Adjusting the presser foot lift



WARNING :

To protect against possible personal injury due to abrupt start of the machine, be sure to start the following work after turning the power off and ascertaining that the motor is at rest.

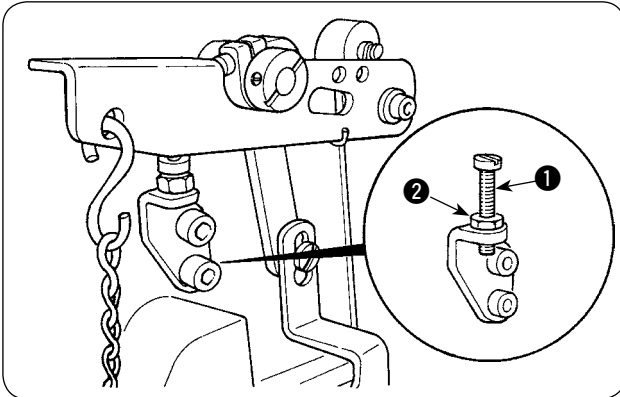

To adjust the height of the presser foot, adjust the height of screw ① so that the presser foot does not come in contact with other components and fix the presser foot with nut ②.

15. Adjusting the micro-lifter



WARNING :

To protect against possible personal injury due to abrupt start of the machine, be sure to start the following work after turning the power off and ascertaining that the motor is at rest.

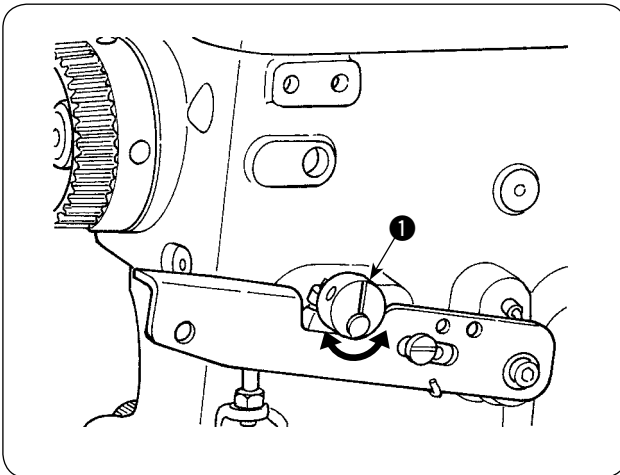

When the micro-lifter collar ① is turned clockwise and counterclockwise, the presser bar lifting lever is pressed down to lift the presser foot.

Adjust the height of the micro-lifter according to the sewing condition.



In the case the micro-lifter is not used, use the sewing machine with the marker line on the micro-lifter collar faced straight up.

16. Adjusting the feed locus



WARNING :

To protect against possible personal injury due to abrupt start of the machine, be sure to start the following work after turning the power off and ascertaining that the motor is at rest.

(1) Changing the feed driving motion

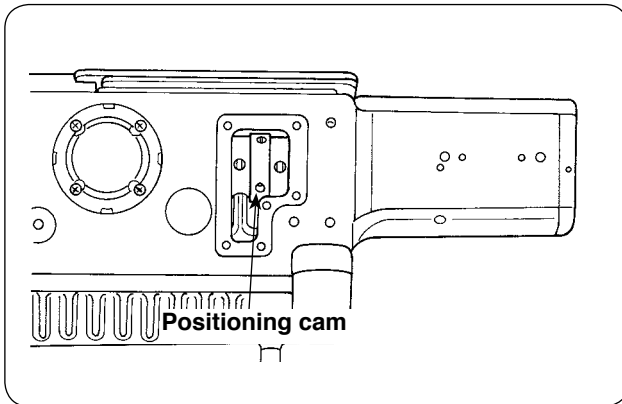

The timing of feed driving eccentric cam of the feed mechanism can be retarded from the timing obtained by the standard adjustment.

- 1) Loosen two setscrews of the feed driving eccentric cam.

Carry out the adjustment when the hole in the feed driving rod aligns with the screw of the feed driving eccentric cam.

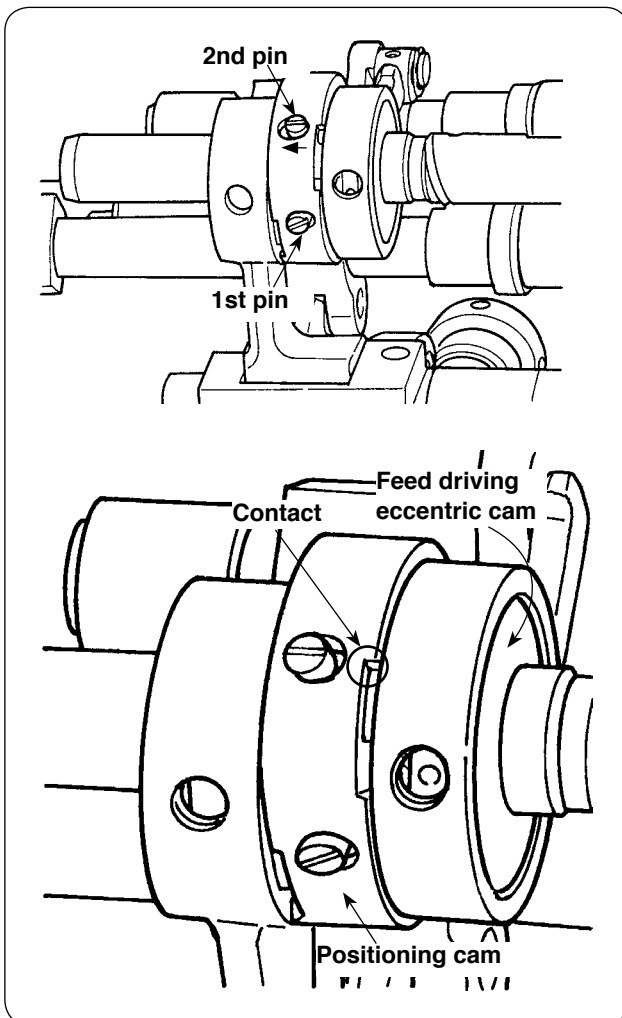

- 2) Shift the 2nd pin to the left.
- 3) Bring the feed driving eccentric cam into contact with the positioning cam.
- 4) Tighten two setscrews of the feed driving eccentric cam.
- 5) To return the timing to the standard adjustment, return the 2nd pin to its home position. Assemble the feed driving eccentric cam and the 2nd pin so that they come in contact with each other. (To obtain the timing of the standard adjustment, the 2nd pin should be positioned at the rightmost end of the hole.)

* To prevent the setscrews from loosening, make sure that the positioning cam comes in contact with the feed driving eccentric cam.

Note that, however, the 2nd pin can move to the right or left. It is therefore necessary to make sure that a clearance is provided between feed driving eccentric cam and positioning cam before checking the timing.

(2) Changing the feed rocking motion

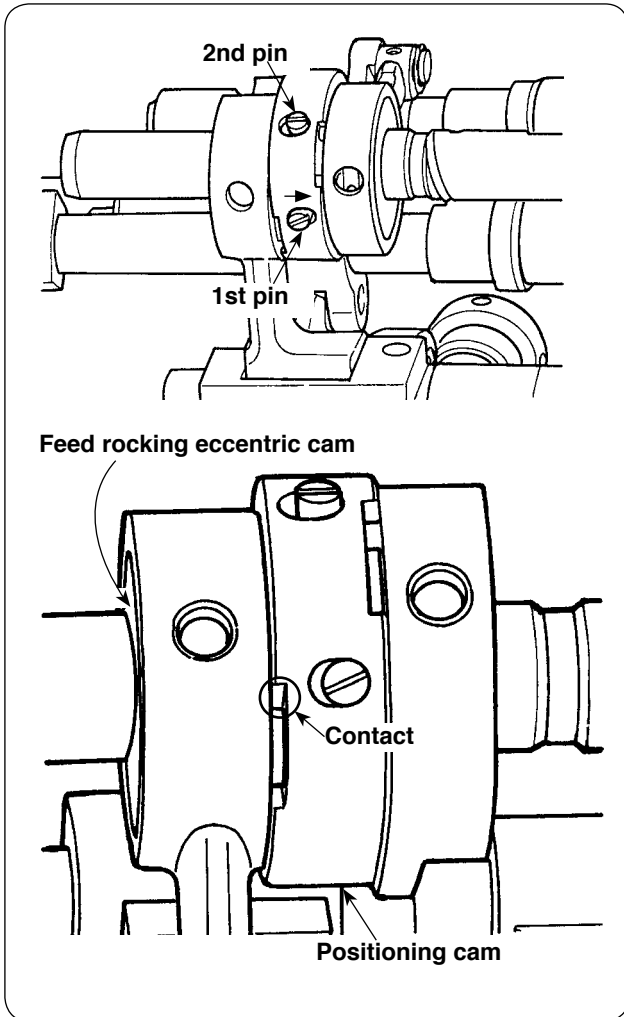
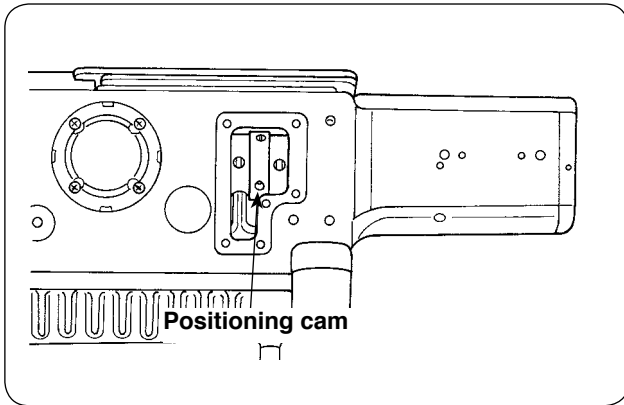

The timing of feed rocking eccentric cam of the feed mechanism can be retarded from the timing obtained by the standard adjustment.

1) Loosen two setscrews of the feed rocking eccentric cam.

Carry out the adjustment when the hole in the feed rocking rod aligns with the screw of the feed rocking eccentric cam.

2) Shift the 1st pin to the right.

3) Bring the feed rocking eccentric cam into contact with the positioning cam.

4) Tighten two setscrews of the feed rocking eccentric cam.

5) To return the timing to the standard adjustment, return the 1st pin to its home position. Assemble the feed rocking eccentric cam and the 1st pin so that they come in contact with each other. (To obtain the timing of the standard adjustment, the 1st pin should be positioned at the leftmost end of the hole.)

* To prevent the setscrews from loosening, make sure that the positioning cam comes in contact with the feed rocking cam.

Note that, however, the 1st pin can move to the right or left. It is therefore necessary to make sure that a clearance is provided between feed rocking eccentric cam and positioning cam before checking the timing.

17. Adjustment value of balloon



WARNING :

To protect against possible personal injury due to abrupt start of the machine, be sure to start the following work after turning the power off and ascertaining that the motor is at rest.

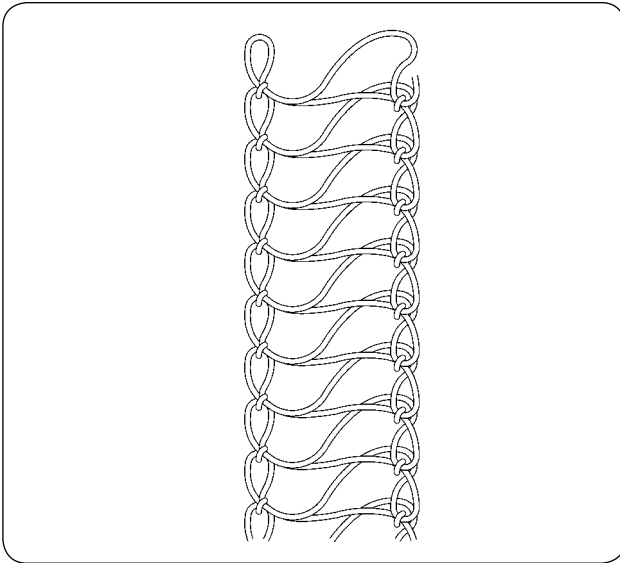

When performing balloon stitch, carry out the adjustment referring to the adjustment values described below.

[2-needle balloon stitch without top covering]

① Feed timing

Feed driving eccentric cam: Retarding the timing.

Feed rocking eccentric cam: Retarding the timing.

Refer to “[VI-16.Adjusting the feed locus](#)” p.24.

② Loper thread cam timing: Loper thread comes off the looper thread cam in the middle between the lower end face and upper end face of the looper.

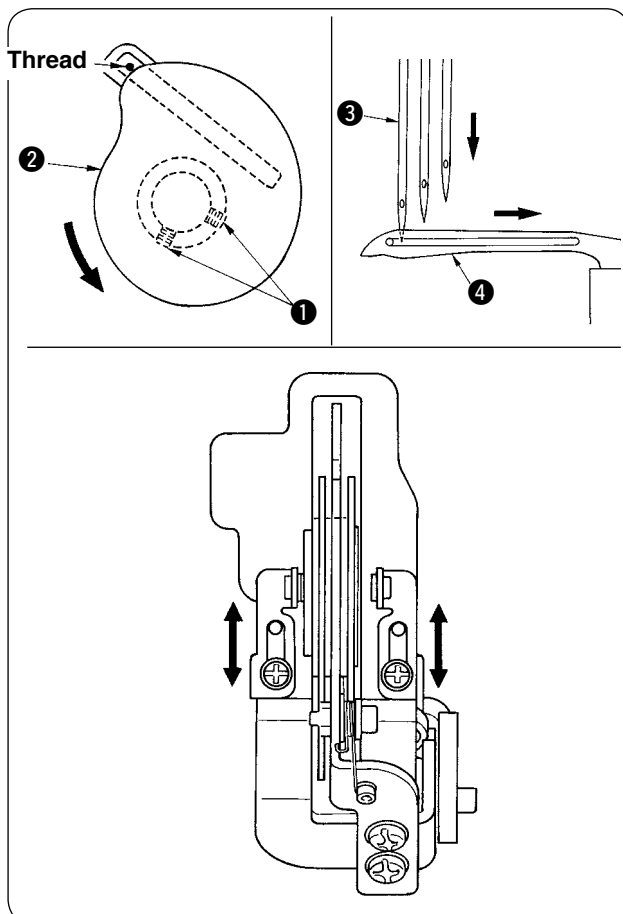

[Adjusting the looper thread cam]

Adjust so that the looper thread comes off the looper thread cam when the top end of the lowering left needle ③ comes to the middle between the lower end face and upper end face of the looper when the lowering left needle. Then, fix the looper thread cam with setscrews ①.

①.

③ Hauling amount of the looper thread cam

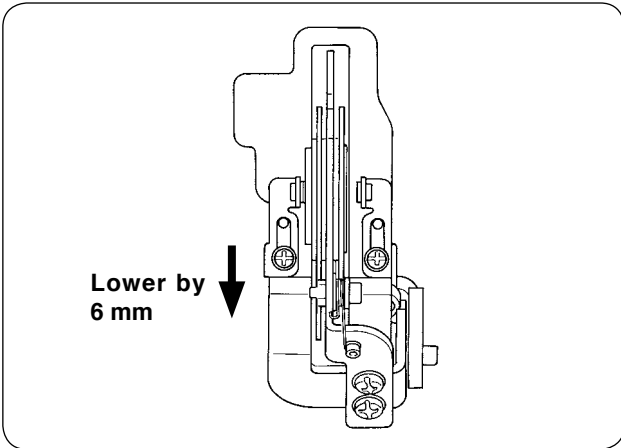

The position 6 mm lower than the standard position
(Standard: Aligns with the upper marker line)

④ Matchstick height

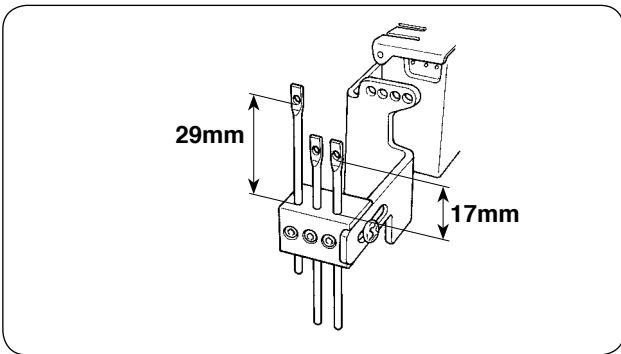

	Matchstick height
Right needle	17mm
Left needle	29mm

⑤ Needle bar thread take-up thread receiver

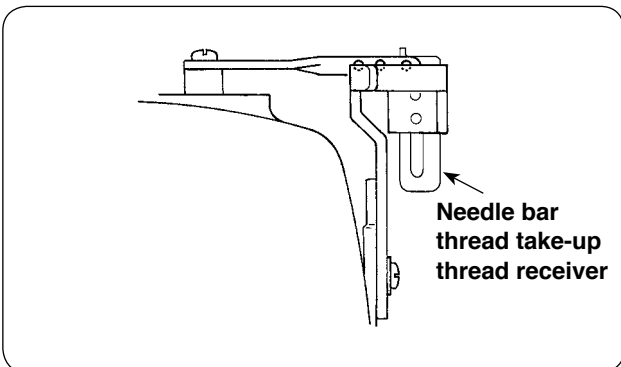

The needle bar thread take-up thread receiver aligns with the top end of the needle bar thread take-up when the needle bar is in its lower dead point.

⑥ D claw (standard: B claw)

⑦ Differential feed ratio

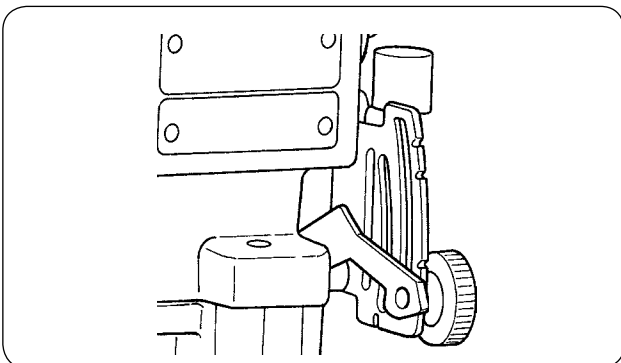

Slightly stretch the material.

VII. MAINTENANCE

1. Cleaning the sewing machine



WARNING :

To protect against possible personal injury due to abrupt start of the machine, be sure to start the following work after turning the power off and ascertaining that the motor is at rest.

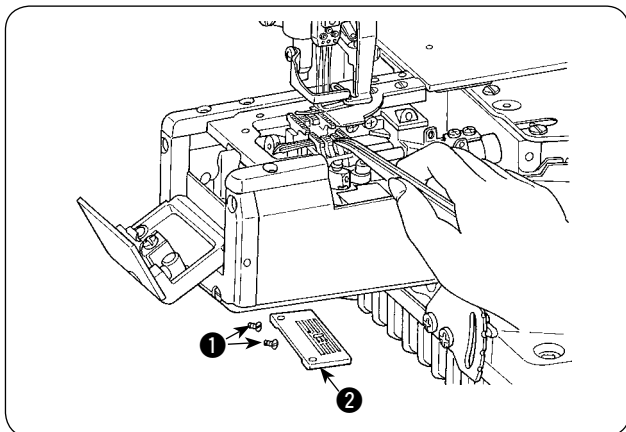

Open the front cover. Remove setscrews ①. Remove throat plate ②. Clean up the slits in the throat plate, grooves in the feed dog and surrounding area. After cleaning, fix throat plate ② with setscrews ①.

2. Replacing the lubricating oil



WARNING :

To protect against possible personal injury due to abrupt start of the machine, be sure to start the following work after turning the power off and ascertaining that the motor is at rest.

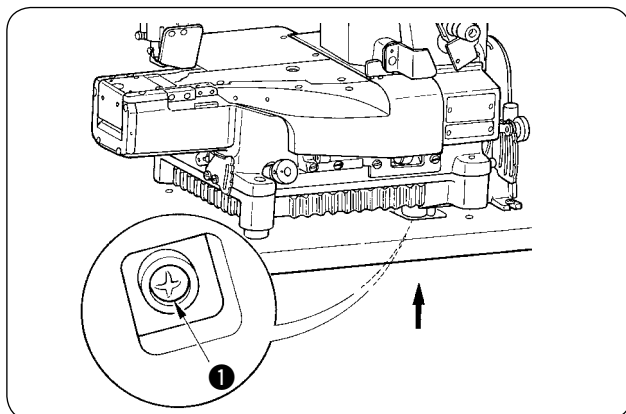

In case of the new sewing machine, replace the lubricating oil (JUKI GENUINE OIL 18) with new one after using it for approximately one month. Then replace the lubricating oil every six months.

- 1) Set a container to receive the lubricating oil under drain screw ①.
- 2) Remove drain screw ①. The lubrication oil is drained.
- 3) After the drain, wipe out the oil and attach the drain screw ①.

3. Inspecting and replacing the oil filter



WARNING :

To protect against possible personal injury due to abrupt start of the machine, be sure to start the following work after turning the power off and ascertaining that the motor is at rest.

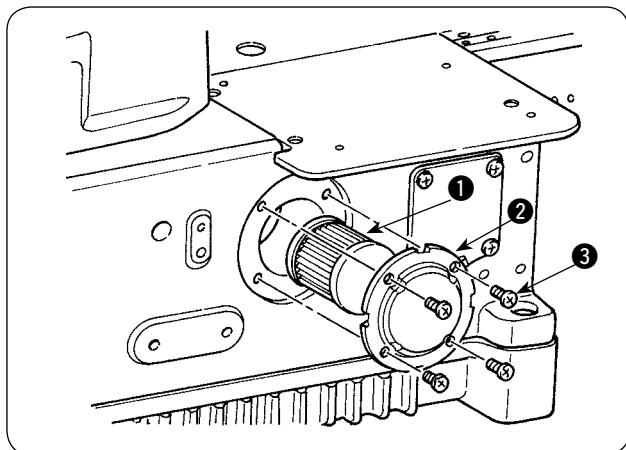

Normal lubrication cannot be performed if dust collects in oil filter ①. Inspect it every 6 months.

- 1) Remove oil filter cap ②, and draw out oil filter ① to inspect it.
- 2) When oil filter ① is clogged with dust, replace it with a new one.
- 3) After the replacement, fix the filter cap ② with screws ③.



When removing the oil filter cap, lubricating oil collected in the filter will leak out. So, be careful.