

PARTS LIST

MD11 PARTS LIST

下記 URL (PARTS Website/PC サイト) より、便利な検索機能のついた Web Parts Book をご利用頂けます。
ご利用には会員登録が必要です。(無料)

<https://juki.aftama.com/JUKI/JA>

You can use a Web Parts Book with a convenient search function from the URLs (PARTS Website/PC-site) below. To use the PARTS Website, free membership registration is required.

<https://juki.aftama.com/JUKI/EN>

HOW TO MAKE USE OF THIS PARTS LIST

1.Explanation of codes

1)"*" mark.....means this part is changed from the previous parts book.

As to the details of the change, refer to the "List for information of change".

2)"#01".....refer to "Note" explanation at bottom of page.

2.Codes on the "Qty" column

- Each numeral indicates the number of parts required.
- "0.1" and "2.5" indicate the length (in meters) of the respective parts.

3.Parentheses mean that the corresponding part is a subpart that constructs an assembly part.

4.Dotted lines on the Figures indicate assembly parts.

CONTENTS

1. DEVICE COMPONENTS	1
2. ACCESSORIE PARTS COMPONENTS	3
3. LIST FOR INFORMATION OF CHANGE.....	5
NUMERICAL INDEX OF PARTS.....	6

1. DEVICE COMPONENTS

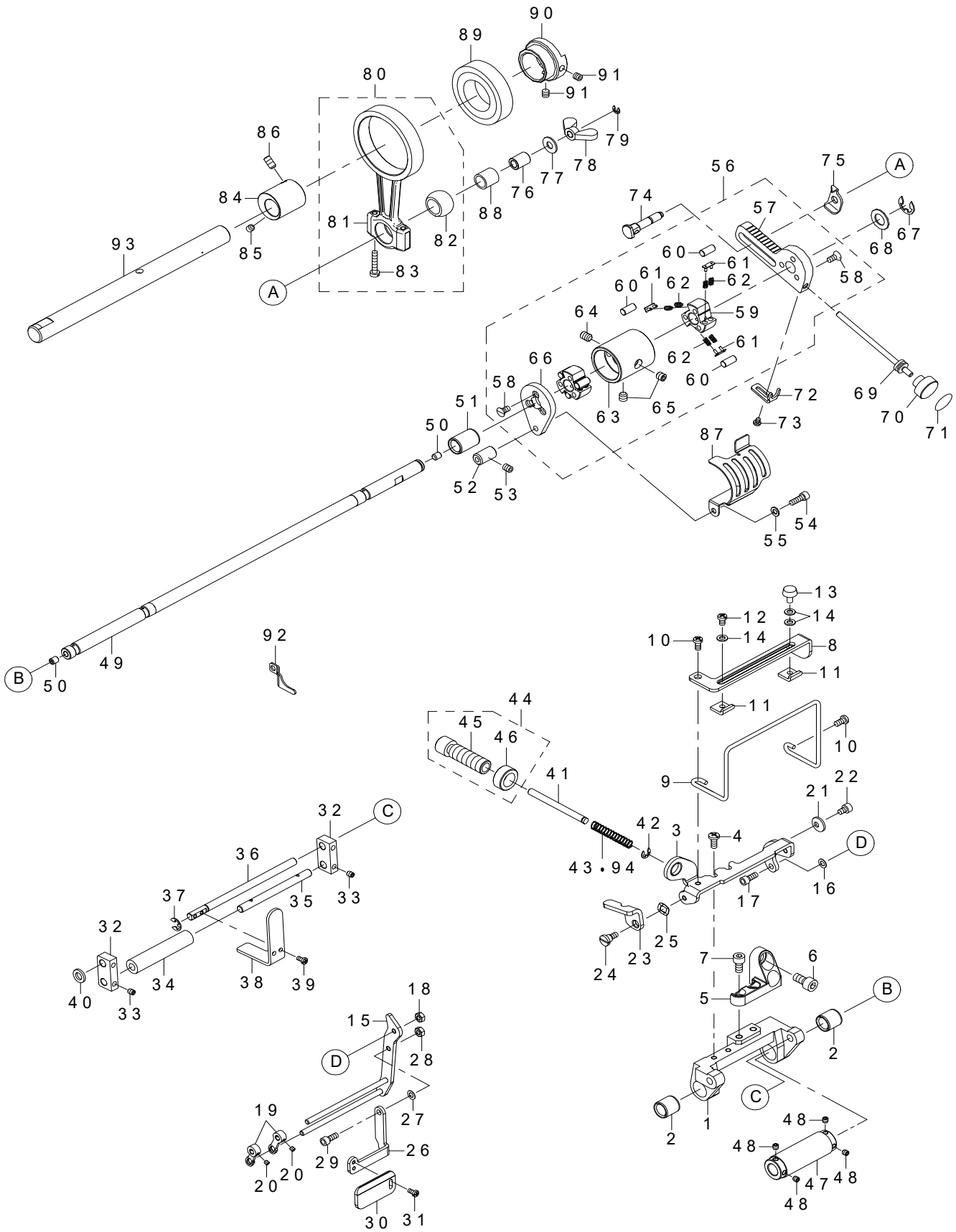

REF.NO	NOTE	PART NO	DESCRIPTION	Qty
1		700-03482	BASE	1
2		400-61169	DRIVE_SHAFT_METAL_B	2
3		700-03486	MD_BASE_PLATE	1
4		SM-5041055-SN	SCREW M4X10	2
5		400-13671	INSTALLING_BASE	1
6		SM-6061202-TP	SCREW M6 L=12	2
7		SM-6051002-TP	SCREW M5X0.8 L=10	2
8		700-03491	GUIDE_PLATE	1
9		700-03479	TAPE_GUIDE	1
10		SM-4040855-SP	SCREW	2
11		400-18265	SIDE_GUIDE_A	2
12		SM-4040655-SP	SCREW M4 L=6	1
13		400-19379	KNOB_SCREW	1
14		WP-0430800-SC	WASHER M4	3
15		700-03487	GUIDE_ARM_ASSY	1
16		WZ-0420350-KP	DISC_SPRING	1
17		SM-6041002-TP	SCREW M4X0.7 L=10	1
18		NM-6040002-SN	NUT M4	1
19		400-79805	TAPE_STOPPER	2
20		SM-8030312-TP	SCREW M3 L=3	2
21		400-79808	STOPPER	1
22		SM-6040602-TP	SCREW M4X0.7 L=6	1
23		400-19606	DRIVEN_ROLLER_STOPPER	1
24	*	700-04493	SHOULDER_ASREW	1
25		WZ-0641510-KP	WAVED_WASHER 6.4X11X0.3	1
26		700-03490	EYE_GUARD_ARM_B	1
27		WZ-0420350-KP	DISC_SPRING	1
28		NM-6040002-SN	NUT M4	1
29		SM-6041002-TP	SCREW M4X0.7 L=10	1
30		400-20003	PROTECTION_SHIELD	1
31		SM-4030655-SP	SCREW	2
32		400-64101	DRIVEN_ROLLER_ARM	2
33		SM-8040512-TP	SCREW	4
34		700-03480	DRIVEN_ROLLER	1
35		700-03481	DRIVEN_ROLLER_SHAFT	1
36		700-03492	DRIVEN_ROLLER_ARM_SHAFT	1
37		RE-0500000-K0	E-RING	1
38		400-18261	PRESSER_PLATE	1
39		SM-4030655-SP	SCREW	2
40		WP-0641600-SC	WASHEW 6.4X12.5X1.6	1
41		400-11178	PRESSER_BAR	1
42		RE-0400000-K0	E-RING 4	1
43		400-19668	SPRING	1
44		400-22666	PRESSER_SPRING_REGULATOR_ASSY	1
45		400-11179	PRESSER_SPRING_REGULATOR	(1)
46		400-11180	NUT	(1)
47		400-62308	DRIVE_ROLLER	1
48		SM-8040412-TP	SET SCREW M4 L=4	4
49		700-03493	DRIVE_SHAFT	1
50		SM-8050612-TP	SCREW M5X6	2
51		400-19621	DRIVE_SHAFT_METAL_A	1
52		400-11189	BUSHING	1
53		SM-8050612-TP	SCREW M5X6	1
54		SM-6041202-TP	SCREW M4X0.7 L=12	1
55		WP-0430800-SC	WASHER M4	1
56		400-72935	CLUTCH_ASSY	1
57		400-72920	FEED_REGULATOR_ARM	(1)
58		SM-1040950-TP	SCREW M4 L=9	(6)
59		400-72914	CLUTCH	(2)
60		400-72916	PIN	(6)
61		400-72919	GUIDE_PLATE_ASSY	(6)
62		400-72922	SPRING	(12)
63		400-72915	DRUM_CLUTCH	(1)
64		SM-8060812-TP	SCREW M6 L=8	(1)
65		SM-8060612-TP	SCREW M6 L=6	(2)
66		400-72921	CLUTCH_MOUNTING_PLATE	(1)
67		RE-0800000-K0	E-SHAPED SNAP RING (8MM)	1
68		WP-1021016-SD	WASHER	1
69		401-01190	FEED_REGULATOR_SCREW	1
70		G6036-870-000	POCKET_PRESSER_KNOB	1
71		112-12503	STOPPER_DIAL_PLATE	1
72		400-11196	FEED_REGULATOR_FIX_PLATE	1
73		SM-4030455-SP	SCREW	2
74		400-11198	FULCRUM_SHAFT	1
75		400-11197	SCALE_POINTER	1
76		700-03471	NEEDLE_INNER_RING	1
77		WP-0621046-SP	WASHER	1
78		NM-9060610-SE	WING NUT M6	1
79		RE-0300000-K0	E-RING 3	1
80		700-03468	FEED_ROD_ASSY	1
81		700-03469	FEED_ROD	(1)
82		700-03470	FEED_ROD_BALL	(1)
83		SM-6042000-SP	SCREW	(2)
84		700-03472	FEED_CAM_A	1
85		SM-8050502-TP	SCREW M5 L=5	1
86		SM-8051002-TP	SCREW M5 L=10	1
87		401-01457	MD_COVER	1
88		700-03465	BEARING	1
89		700-03467	BEARING	1
90		700-03473	FEED_CAM_B	1
91		SM-8050502-TP	SCREW M5 L=5	2
92		700-03994	FINGER_GUARD_MD11	1
93		700-03474	UPPER_MAINSHAFT_RIGHT	1
94	#01	400-75049	SPRING	1
		NOTE	#01....OPTIONAL PARTS	

2. ACCESSORIE PARTS COMPONENTS

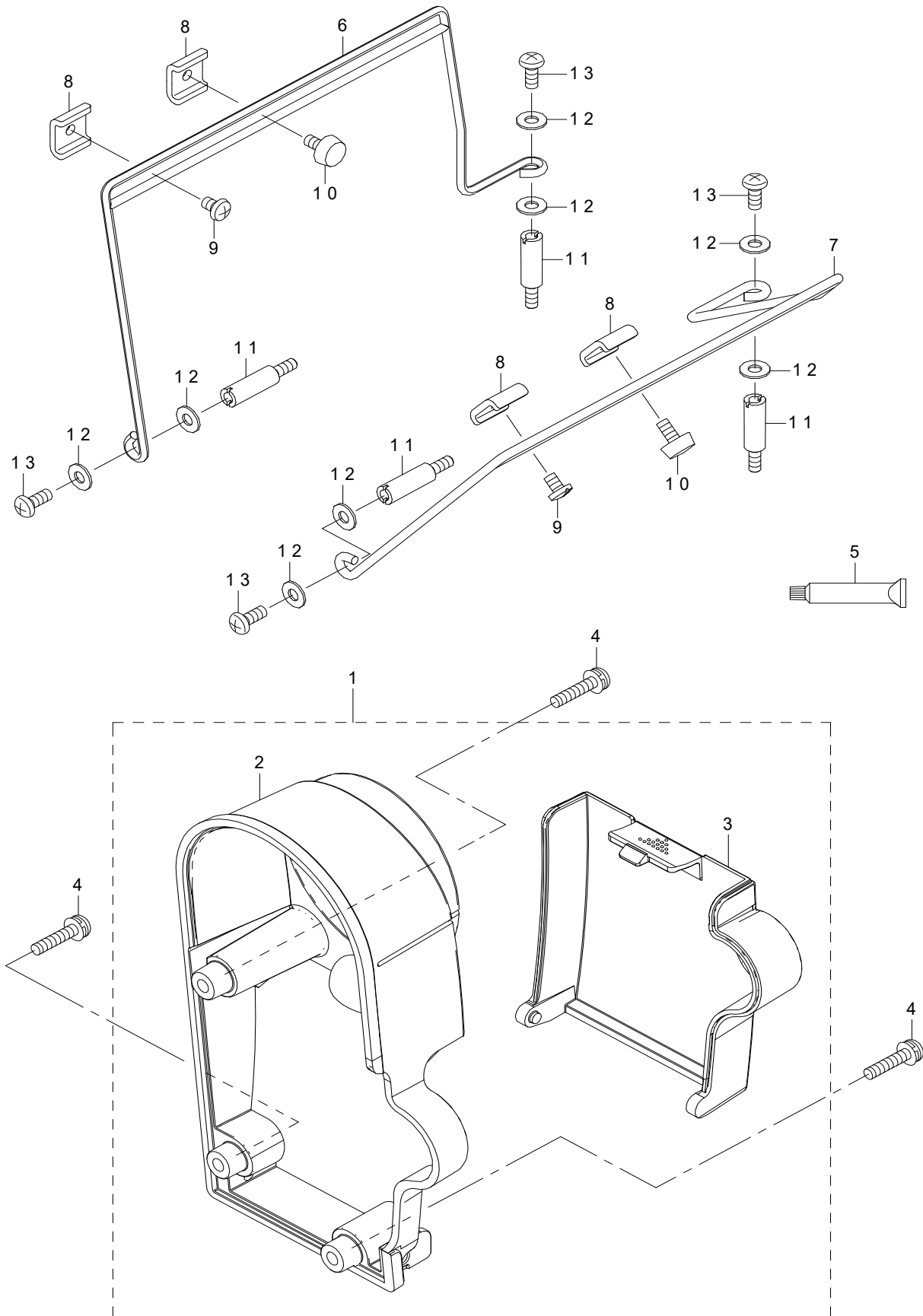

REF.NO	NOTE	PART NO	DESCRIPTION	Qty
1		700-03475	PULLEY_COVER_ASSY	1
2		700-03476	PULLEY_COVER_A	(1)
3		700-03477	PULLEY_COVER_B	(1)
4		SL-4042091-SC	SCREW M4X0.7 L=20	3
5		135-25506	GREASE TUBE	1
6		400-72924	SUPPORT GUIDE C	1
7		400-12144	SUPPORT GUIDE_A	1
8		400-18266	SIDE GUIDE_B	4
9		SM-5040655-SN	SCREW	2
10		400-19379	KNOB_SCREW	2
11		400-11205	STUD	4
12		WP-0450826-SC	WASHER 4.5X10X0.8	8
13		SM-4041055-SP	SCREW	4

3. LIST FOR INFORMATION OF CHANGE

As to the place changed, refer to the corresponding Rev. No.
 When previous parts (Obsoleted part) and new parts (Added parts) are not interchangeable with each other:
 In this case, even obsoleted parts (D.) can be ordered with the obsoleted part number, so select the parts with changed dates and place your orders.

変更箇所は、該当Rev. No. 版をご参照ください。
 部品の互換性がない変更の場合は、削除された品番でも、ご注文できます。

No. 1640-01・・・Rev. No.

*A : Added parts 追加部品 / D : Obsoleted parts 削除部品 / E : Erratum 訂正

*	Rev. No.	Page 頁	Ref. No.	Parts No. 品番	*	Rev. No.	Page 頁	Ref. No.	Parts No. 品番
D	00	2	24	SD-0600406-TP	A	01	2	24	700-04493

NUMERICAL INDEX OF PARTS

PART NO	PAGE	REF NO	PART NO	PAGE	REF NO	PART NO	PAGE	REF NO	PART NO	PAGE	REF NO
G6036-870-000	2	70	400-72914	2	59						
			400-72915	2	63						
NM-6040002-SN	2	18	400-72916	2	60						
NM-6040002-SN	2	28	400-72919	2	61						
NM-9060610-SE	2	78	400-72920	2	57						
			400-72921	2	66						
RE-0300000-K0	2	79	400-72922	2	62						
RE-0400000-K0	2	42	400-72924	4	6						
RE-0500000-K0	2	37	400-72935	2	56						
RE-0800000-K0	2	67	400-75049	2	94						
			400-79805	2	19						
SL-4042091-SC	4	4	400-79808	2	21						
SM-1040950-TP	2	58	401-01190	2	69						
SM-4030455-SP	2	73	401-01457	2	87						
SM-4030655-SP	2	31									
SM-4030655-SP	2	39	700-03465	2	88						
SM-4040655-SP	2	12	700-03467	2	89						
SM-4040855-SP	2	10	700-03468	2	80						
SM-4041055-SP	4	13	700-03469	2	81						
SM-5040655-SN	4	9	700-03470	2	82						
SM-5041055-SN	2	4	700-03471	2	76						
SM-6040602-TP	2	22	700-03472	2	84						
SM-6041002-TP	2	17	700-03473	2	90						
SM-6041002-TP	2	29	700-03474	2	93						
SM-6041202-TP	2	54	700-03475	4	1						
SM-6042000-SP	2	83	700-03476	4	2						
SM-6051002-TP	2	7	700-03477	4	3						
SM-6061202-TP	2	6	700-03479	2	9						
SM-8030312-TP	2	20	700-03480	2	34						
SM-8040412-TP	2	48	700-03481	2	35						
SM-8040512-TP	2	33	700-03482	2	1						
SM-8050502-TP	2	85	700-03486	2	3						
SM-8050502-TP	2	91	700-03487	2	15						
SM-8050612-TP	2	50	700-03490	2	26						
SM-8050612-TP	2	53	700-03491	2	8						
SM-8051002-TP	2	86	700-03492	2	36						
SM-8060612-TP	2	65	700-03493	2	49						
SM-8060812-TP	2	64	700-03994	2	92						
			700-04493	2	24						
WP-0430800-SC	2	14									
WP-0430800-SC	2	55									
WP-0450826-SC	4	12									
WP-0621046-SP	2	77									
WP-0641600-SC	2	40									
WP-1021016-SD	2	68									
WZ-0420350-KP	2	16									
WZ-0420350-KP	2	27									
WZ-0641510-KP	2	25									
112-12503	2	71									
135-25506	4	5									
400-11178	2	41									
400-11179	2	45									
400-11180	2	46									
400-11189	2	52									
400-11196	2	72									
400-11197	2	75									
400-11198	2	74									
400-11205	4	11									
400-12144	4	7									
400-13671	2	5									
400-18261	2	38									
400-18265	2	11									
400-18266	4	8									
400-19379	2	13									
400-19379	4	10									
400-19606	2	23									
400-19621	2	51									
400-19668	2	43									
400-20003	2	30									
400-22666	2	44									
400-61169	2	2									
400-62308	2	47									
400-64101	2	32									