

ENGLISH

**MEB-3900
INSTRUCTION MANUAL**

CONTENTS

1. SPECIFICATIONS.....	1
2. NAME OF EACH COMPONENT	2
3. INSTALLATION.....	3
3-1. Table.....	3
(1) Drawing of the stand.....	3
(2) Drawing of the table(Table-fixed type)	4
(3) Drawing of the table (Semi-sunken type).....	5
3-2. Installing the control box	6
3-3. Installing and connecting the power switch	6
3-4. Taking out the sewing machine.....	8
3-5. Installing the sewing machine	9
(1) In the case of the table-fixed type machine head.....	9
(2) In the case of the semi-sunken type machine head.....	11
3-6. Raising and returning the sewing machine.....	16
3-7. Installing the poly oiler.....	19
3-8. Installing the operation panel	20
3-9. Installing the regulator and the manifold	21
3-10. Connecting the cords	23
3-11. Handling the cords.....	24
3-12. Installing the foot pedal switch (optional).....	25
3-13. Connecting the air supply	26
(1) Connecting the regulator and the manifold.....	26
(2) Connecting the air tubes	27
3-14. Installing the air hose	28
3-15. Cautions for the compressed air supply (source of supply air) facility	29
3-16. Installing the thread stand	30
3-17. Installing the thread guides	31
3-18. Installing the eye protection cover and the finger guard	32
3-19. Installing the cloth chip bag	33
3-20. Installing/removing the presser unit.....	34
4. PREPARATION BEFORE OPERATION.....	35
4-1. Lubrication of the machine and how to lubricate ..	35
(1) Lubricating the arm oil tank	35
(2) Lubricating the bed oil tank	35
(4) Lubricating the looper bracket oil tank.....	36
(3) Lubricating the looper and spreader components	36
(5) Lubricating the needle bar and the gear section	37
4-2. Attaching the needle.....	38
4-3. Threading the machine head	39
(1) Threading the upper thread (needle thread).....	39
(2) Threading the lower thread (looper thread).....	40
(3) Threading the machine with gimp	41
4-4. How to set the cloth on the sewing machine	41
5. STRUCTURE OF THE OPERATION SWITCH	42
5-1. Structure of the operation panel	42
5-2. Temporary stop switch.....	44
5-3. Hand switch.....	44
5-4. Foot switch (optional).....	44
6. HOW TO USE THE OPERATION PANEL	45
6-1. Basic operation of the sewing machine	45
6-2. Setting the thread tension.....	45
6-3. Temporarily stopping the sewing machine	46
6-4. Performing re-sewing	47
6-5. Performing threading	48
6-6. How to use the counter	48
(1) Setting procedure of the counter value	48
(2) Count-up releasing procedure.....	49
6-7. When dropping of the knife is temporarily not desired	50
6-8. Changing the operation mode	50
6-9. Changing procedure of the sewing pattern.....	52
6-10. Confirming the pattern shape.....	52
7. SETTING PROCEDURE OF THE SEWING DATA.....	53
7-1. Setting the knife No.	54
7-2. Setting the cut length	55
7-3. Setting the cut-before/cut-after knives	55
7-4. Setting the number of stitches of the parallel section.....	56
7-5. Setting the number of stitches of the eyelet	56
7-6. Setting the cut space.....	57
7-7. Setting the eyelet space	57
7-8. Knife position compensation.....	58
7-9. Number of stitches of sewing end compensation .	58
7-10. Turning angle compensation	59
7-11. Turning angle compensation at the parallel sec- tion.....	59
7-12. Compensation of eyelet in lateral direction	60
7-13. Compensation of eyelet in longitudinal direction	60
7-14. Compensation of eyelet, left in longitudinal direction	61
7-15. Compensation of left parallel section of a but- tonhole	61
7-16. Compensation of cutting space, left.....	62
7-17. Setting the needle throwing width of the right bottom of eyelet	62
7-18. Setting the needle throwing width of the left bottom of eyelet	63
7-19. Setting the needle throwing width	63
7-20. Setting the type of bartack.....	64
7-21. Setting the length of taper bar.....	64
7-22. Setting the number of stitches of taper bar	65
7-23. Setting the offset of taper bar.....	65
7-24. Setting the number of stitches of slant section of taper bar	66
7-25. Compensation of the number of stitches of the right side taper bar.....	66
7-26. Setting the straight bar length.....	67
7-27. Setting the number of stitches of straight bar....	67
7-28. Setting the overlapping amount of straight bar... 68	
7-29. Setting the needle throwing width of straight bar	68
7-30. Setting the number of stitches of round bar	69
7-31. Setting the number of overlapping stitches of round bar 2	69
7-32. Setting the needle throwing width of the round bar.....	70
7-33. Setting the needle throwing width at the upper section of eyelet bar	70
7-34. Setting the reduced sewing speed for straight/ round bar	71

7-35. Setting the sewing speed.....	71	10-8. Height of the throat plate	103
7-36. Setting the reduction speed of eyelet.....	71	(1) Height of the throat plate.....	103
7-37. Setting the soft start.....	72	(2) Adjusting the height of the throat plate	103
7-38. Setting the number of stitches at the beginning of sewing of thread tension	72	10-9. Position of the presser foot.....	104
7-39. Setting the number of stitches at the end of sewing of thread tension	72	10-10. Adjusting the knife dropping position	104
7-40. Setting the basting pattern number	73	10-11. Installing position of the needle thread trimming knife	105
7-41. Setting the prohibition of opening during basting.....	73	10-12. Cleaning.....	106
7-42. Setting the number of stitches for sewing a radial stitch eyelet	73	10-13. Draining	106
7-43. Setting the overlap stitching angle for the radial stitch eyelet.....	74	10-14. Replacing consumables.....	107
7-44. Setting the radial stitch eyelet diameter	74	(1) Worn-out of the hammer face	107
8. ADJUSTMENT OF EACH PART	75	(2) Replacing the cloth cutting knife and the hammer..	108
8-1. Adjusting the pressure of the cloth trimming knife.....	75	(3) Replacing the looper thread trimming knife (overall thread trimmer type)	109
8-2. Adjusting the stitch bite width.....	76	(4) Replacing the needle thread trimming knife	110
8-3. Adjusting the presser	77	(5) Changing the thread trimmer retaining plate (needle thread trimmer type)	110
8-4. Adjusting the presser opening amount	78	(6) Standard of replacing time of the gas spring.....	110
8-5. Adjusting the needle thread drawing amount.....	79	(7) Replacing the gas spring	111
8-6. Adjusting the thread take-up thread guide.....	79	11. EXCHANGING GAUGE PARTS AND OPTIONAL	112
8-7. Adjusting the remaining amount of the gimp.....	80	11-1. Throat plate.....	112
8-8. Adjusting the gimp thread tension.....	80	11-2. Presser set.....	112
8-9. Needle thread clamp unit (optional).....	81	11-3. Presser holding plate.....	113
8-10. Adjusting the brightness of the hand lamp.....	82	11-4. Cloth cutting knife.....	113
9. HOW TO USE THE VARIOUS FUNCTIONS	83	11-5. Hammer.....	114
9-1. Operating procedure of thread tension compensation of each section	83	11-6. Others.....	114
9-2. Changing the setting position of cloth	86	12. TROUBLES AND CORRECTIVE MEASURES IN SEWING	115
9-3. Changing over the mode of the start switch.....	86	13. MEMORY SWITCH	117
9-4. Changing over the presser movement	86	13-1. Operating procedure	117
9-5. Changing over to the mode of the stop before cloth cut	86	13-2. Memory switch list.....	118
9-6. How to copy / delete the sewing pattern	87	14. ERROR LIST	120
9-7. How to adjust the contrast.....	88	15. STANDARD PATTERN LIST	123
9-8. How to set the key lock	88	16. SEWING DATA ENTRY SHEET.....	125
9-9. Using parameter register key	89		
(1) Method of register.....	89		
(2) Register status at the time of your purchase	89		
9-10. Communication.....	90		
(1) USB thumb drive	91		
(2) NFC.....	92		
9-11. Setting the irregular work.....	93		
10. MAINTENANCE	95		
10-1. Looper thread trimming (overall thread trimmer type).....	95		
10-2. Timing between the needle and the looper	95		
10-3. Height of the needle bar	98		
(1) Adjusting the needle bar height.....	98		
(2) Reference height of the needle bar	98		
10-4. Adjustment to prevent triangular stitch skipping in the case of a narrow needle throwing width.....	99		
10-5. Clearance between the needle and the looper... ..	100		
10-6. Adjusting the needle guard.....	100		
10-7. Clearance between the spreader and looper and the opening timing of the spreader.....	101		

1. SPECIFICATIONS

	Specifications	J type		C type	
1	Application	Jeans		Cotton pants, working pants	
2	Operating temperature range	5°C to 35°C			
3	Operating humidity range	35 % to 85 % (with no condensation)			
4	Number of patterns that can be stored in memory	99 (1 to 99) (standard patterns have been factory-numbered 90 to 99)			
5	Input power	Single-/3-phase 200 to 240 V 50/60 Hz Supply voltage fluctuation: Rating \pm 10 %			
6	Sewing speed	400 to 2,500 sti/min (in 100 sti/min steps)			
7	Thread trimmer type	Needle thread trimmer type (00)	Overall thread trimmer type (01)	Needle thread trimmer type (00)	Overall thread trimmer type (01)
8	Sewing length	10 to 38 mm	10 to 34 mm	10 to 38 mm	10 to 34 mm
9	Buttonhole length	10 to 38 mm *1	10 to 28 mm	10 to 38 mm *1	10 to 28 mm
10	Needle throwing width	2.0 to 4.0 mm (factory-setting at the time of delivery: 2.5 mm) [1.5 to 5.0 mm by compensation on the feed panel]			
11	Length of buttonhole with taper bar	3 to 15 mm *2			
12	Lift of presser foot	Standard 13 mm			
13	Change of stitch shape	Selection by program			
14	Buttonhole cutting	Cut-before knife + Cut-after knife, without knife			
15	Cloth cutting knife drive method	Driven by air cylinder			
16	Feed method	Intermittent feed by stepping motor			
17	Needle used	DO \times 558 Nm90 to 120 (Needle count attached at the time of delivery: Nm110)			
18	Safety device	Pause switch & automatic stop function at the time of detection of a trouble			
19	Lubricating oil	JUKI New Defrix Oil No. 2 or JUKI MACHINE Oil No. 18			
20	Air pressure	Main regulator: 0.5 MPa Hammer pressure regulator: Standard 0.35 MPa (max. 0.4 MPa)			
21	Air consumption	49.5 ℓ /min (11.6 cycles/min)			
22	Machine dimensions	Machine head: 382 mm (width) \times 656 mm (length) \times 584 mm (height) Complete unit (Table-fixed type) : 1050 mm (width) \times 700 mm (length) \times 1248 mm (height) *3 (excluding the thread stand) Complete unit (Semi-sunken type) : 1060 mm (width) \times 790 mm (length) \times 1096 mm (height) *3 (excluding the thread stand)			
23	Power consumption	200 VA			
24	Mass	Machine head: Approx. 110 kg; Operation panel: Approx. 0.3 kg Control box: Approx. 4.5 kg			
25	Noise	<ul style="list-style-type: none"> - Equivalent continuous emission sound pressure level (L_{pA}) at the workstation : A-weighted value of 82.0 dB; (Includes $K_{pA} = 2.5$ dB); according to ISO 10821-C.6.3 -ISO 11204 GR2 at 2,500 sti/min for the sewing cycle, 3.8 sec. (Pattern : No.90). - Sound power level (L_{WA}) ; A-weighted value of 92.5 dB; (Includes $K_{WA} = 2.5$ dB); according to ISO 10821-C.6.3 -ISO 3744 GR2 at 2,500 sti/min for the sewing cycle, 3.8 sec. (Pattern : No.90). 			

*1 : For the machine provided with the optional needle thread clamp unit, the buttonhole length is 10 to 28 mm.

*2 : Parallel section: Taper length can be set to such a value that does not exceed the total of the eyelet section and the bartacking section.

*3 : The height of the completed unit differs with the height of the table stand.

2. NAME OF EACH COMPONENT

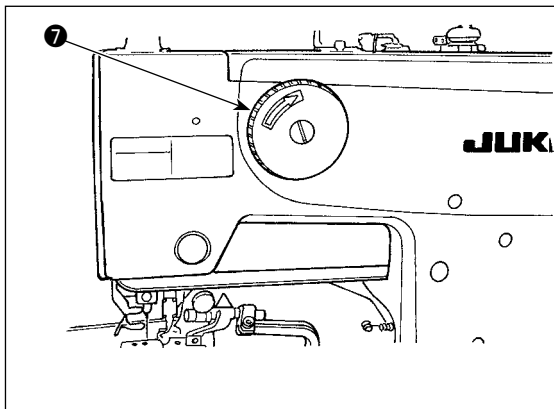

- Hand pulley ⑦
The needle bar can be lifted or lowered by hand with the hand pulley.

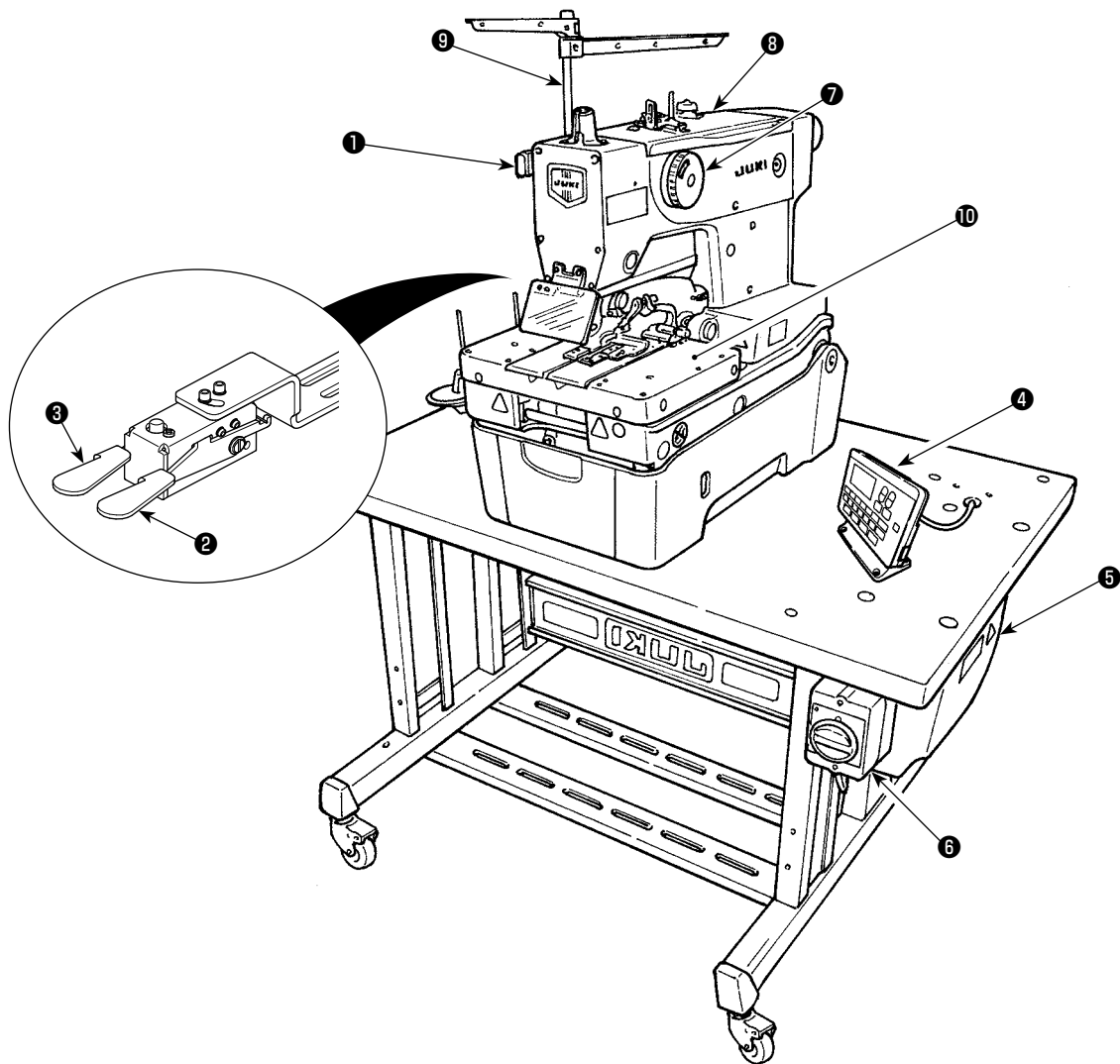

- ① Temporary stop switch
- ② Presser switch
- ③ Start switch
- ④ Operation panel

- ⑤ Control box
- ⑥ Power switch
- ⑦ Hand pulley
- ⑧ Machine head

- ⑨ Thread stand
- ⑩ Feed base

3. INSTALLATION

DANGER :



1. The sewing machine should be installed by a trained technician.
2. Contact the distributor or a professional electrician to ask him/her to carry out electric wiring.
3. The sewing machine has a mass of approximately 110 kg. Four or more workers are required to carry out the installation of the sewing machine and adjustment of the table height.
4. Never connect the power plug until the installation of the sewing machine is completed in order to protect against an accident due to an abrupt startup of the sewing machine.
5. Be sure to ground the earthing wire in order to protect against an accident due to electrical leakage.
6. Be sure to raise/return the sewing machine from/to its home position by holding it with both hands.
7. Do not apply an unreasonable force to the sewing machine when it is in the raised position. If such a force is applied, the sewing machine can lose its balance to fall alone or fall together with the table, resulting in personal injury or sewing-machine breakage.

3-1. Table

- Use the table and stand which are able to withstand the sewing machine mass (110 kg) and vibration. The table thickness of which is 40 - 60 mm should be used.
- Use the table stand which has an appropriate height for the sake of the operator's ease of use.
- The fixing bolt for fixing the table and the stand should be of the length which matches the thickness of the table.
- The table differs between the table-fixed type and the semi-sunken type machine heads. Appropriately machine the table referring to the table drawing corresponding to the type of the machine head.



1. In the case the table thickness exceeds 60 mm, the length of the bolts supplied with the unit as accessories is adequate.
2. In the case the fixing bolt for fixing the table and the stand is too long for the table thickness, unexpected injury to hands or head can occur.

(1) Drawing of the stand

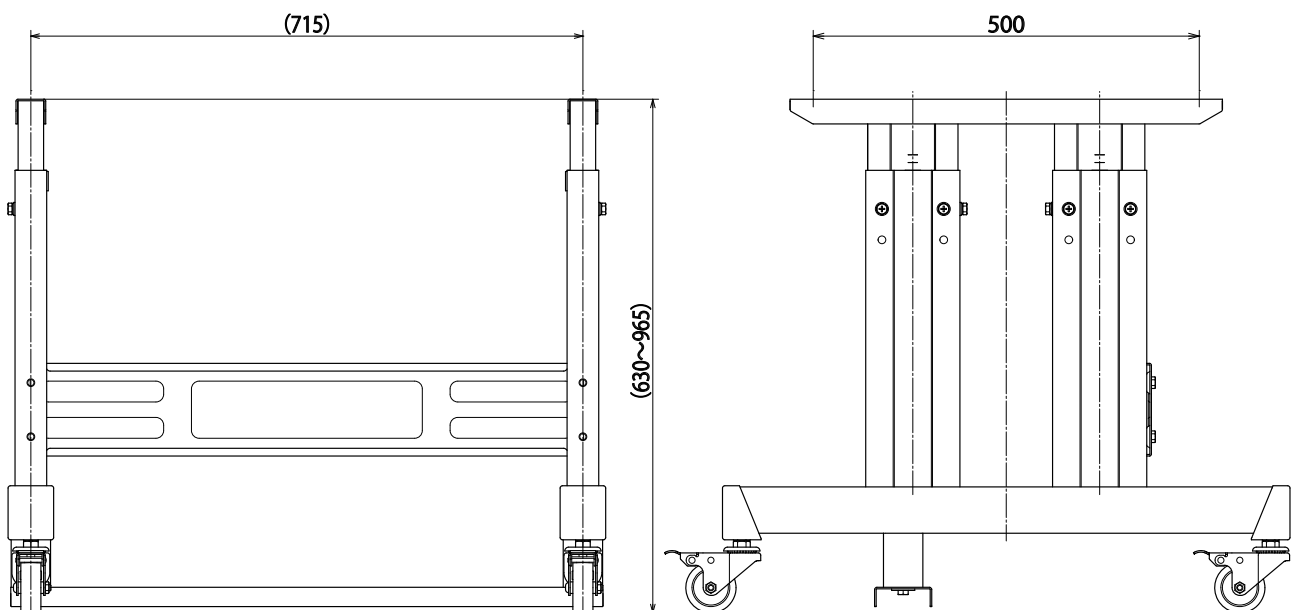

(2) Drawing of the table (Table-fixed type)

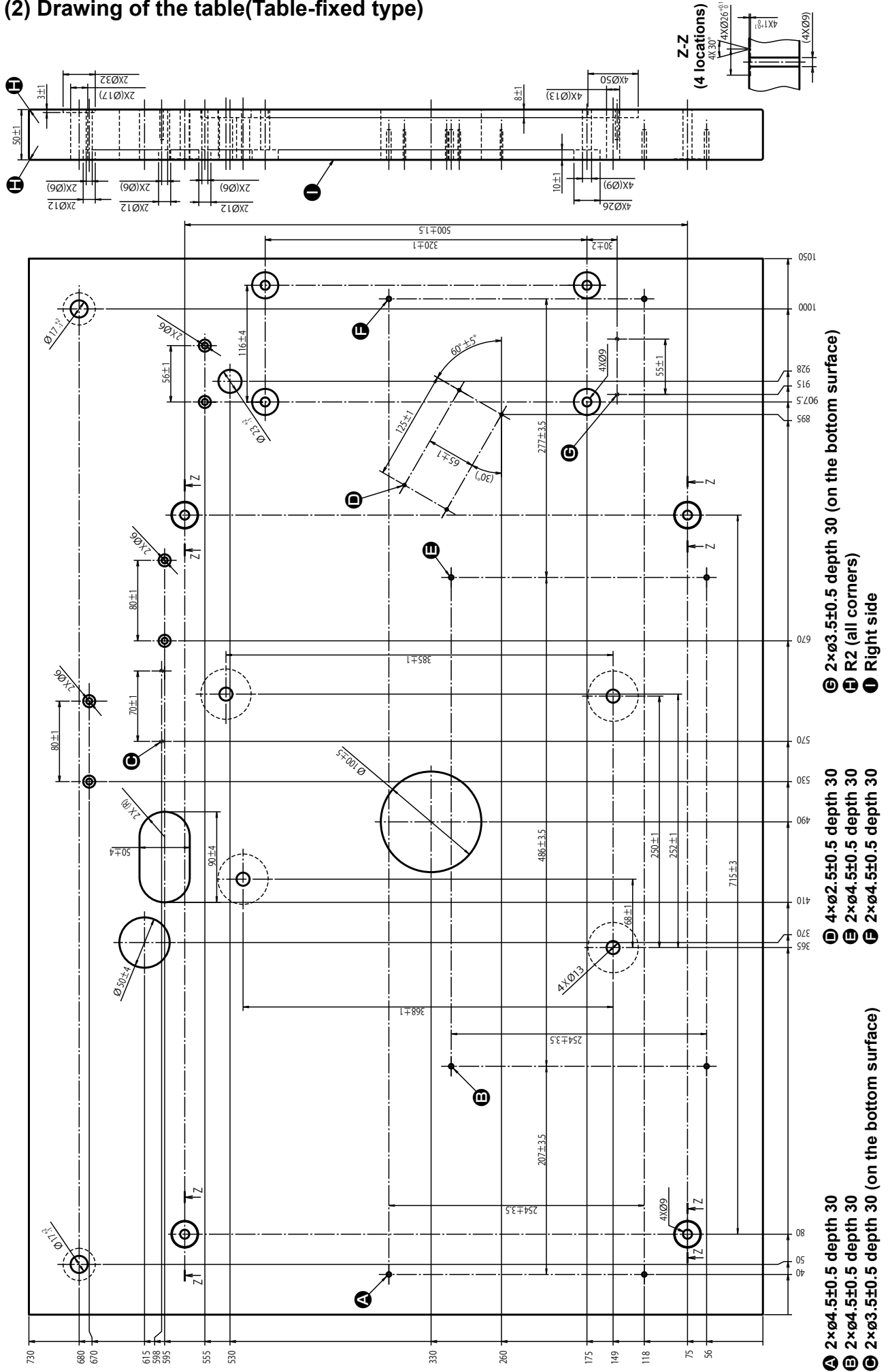

(3) Drawing of the table (Semi-sunken type)

In the case the semi-sunken type machine head is used, the kit for semi-sunken type (part number : 40157881) is required. Prepare the kit simultaneously with the table.



In the case the semi-sunken type machine head is used, the table reinforcing plate (part number: 32080707) (supplied with the kit (part number: 40157881)) has to be installed without exceptions. (Refer to "3-5.(2) ① Installing the table reinforcing plate" p. 11.)

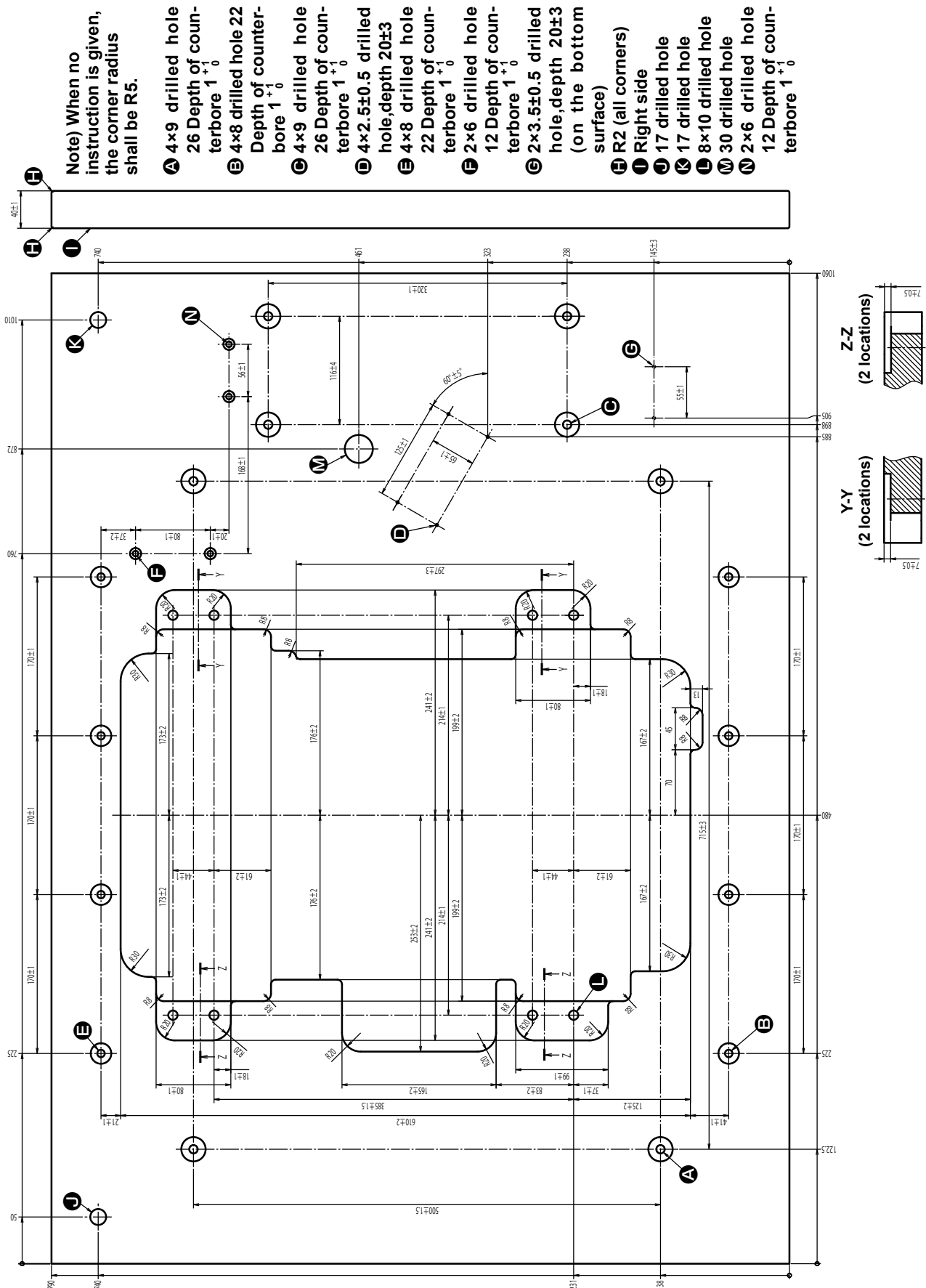

3-2. Installing the control box

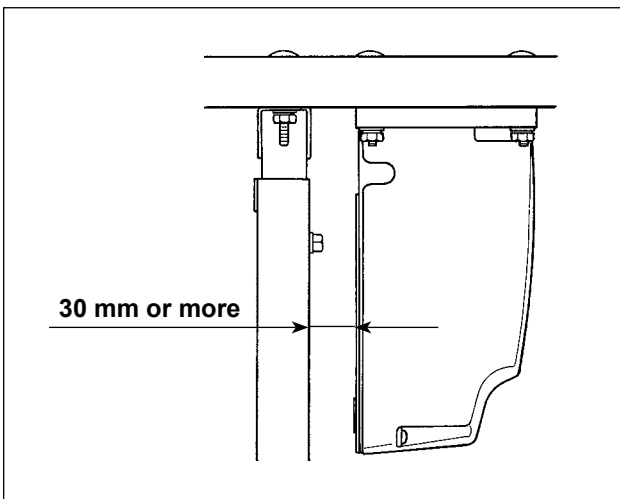
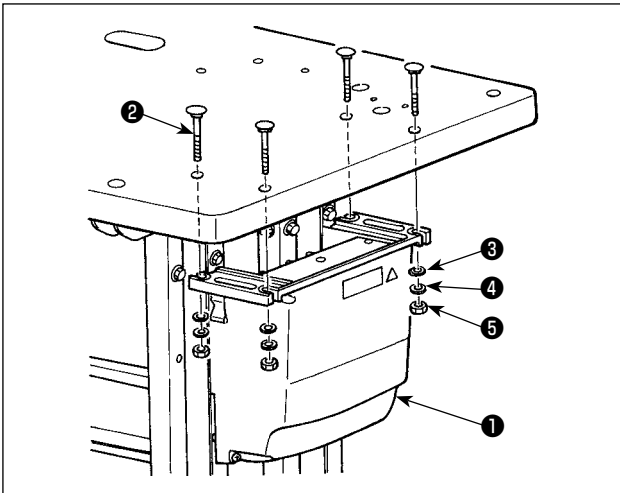

Install control box ① to the location illustrated in the figure using four bolts ②, four plain washers ③ and four spring washers ④ and four hexagonal nuts ⑤ supplied with the unit.

1. Install control box ① 30 mm or more away from the stand. If control box ① is located too close to the stand, the former can get hot or the sewing machine can malfunction.



2. In the case the semi-sunken type machine head used, install the control box after carrying out the procedure written in "3-9. Installing the regulator and the manifold" p. 21.



Bolt ② is a cup head square neck bolt (M8; Length: 70 mm) and nut ⑤ is a hexagonal nut (M8).

3-3. Installing and connecting the power switch

1) Installing the power switch

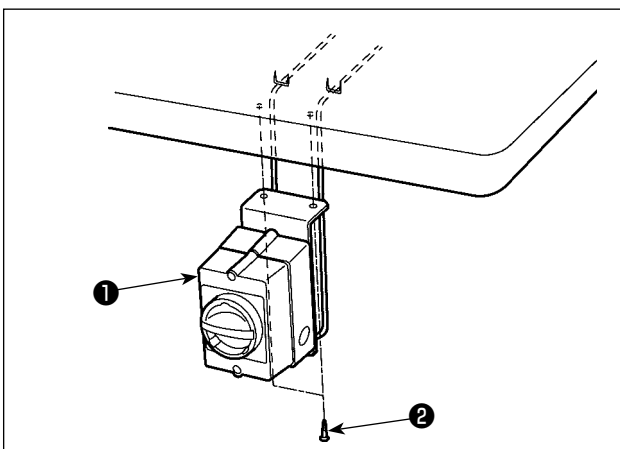

Fix power switch ① on the underside of the table with two wood screws ②.



In the case the semi-sunken type machine head used, install the control box after carrying out the procedure written in "3-9. Installing the regulator and the manifold" p. 21.



Wood screw ② has the nominal diameter of 5.1 mm and a length of 20 mm.

2) Connecting the power cable

Voltage specifications are shown on the power indication tag attached on the power cable and on the rating plate adhered on the power box. Connect the cable which matches the specifications.

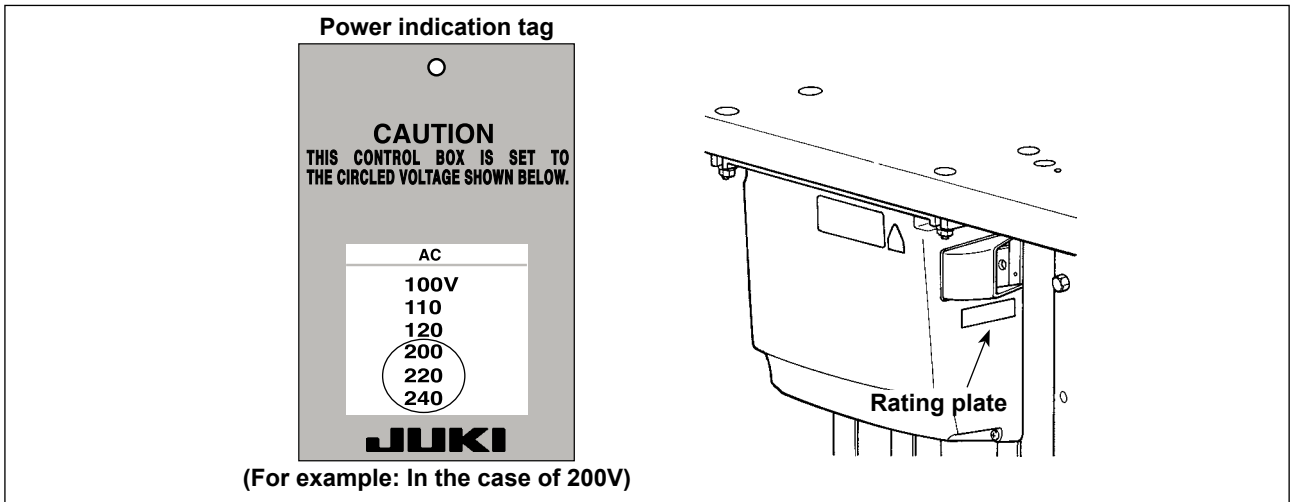

Caution Never use the machine unless the voltage specifications described on the power indicator label are satisfied.

- Connecting three phase 200V to 240V

- Connecting single phase 200V to 240V

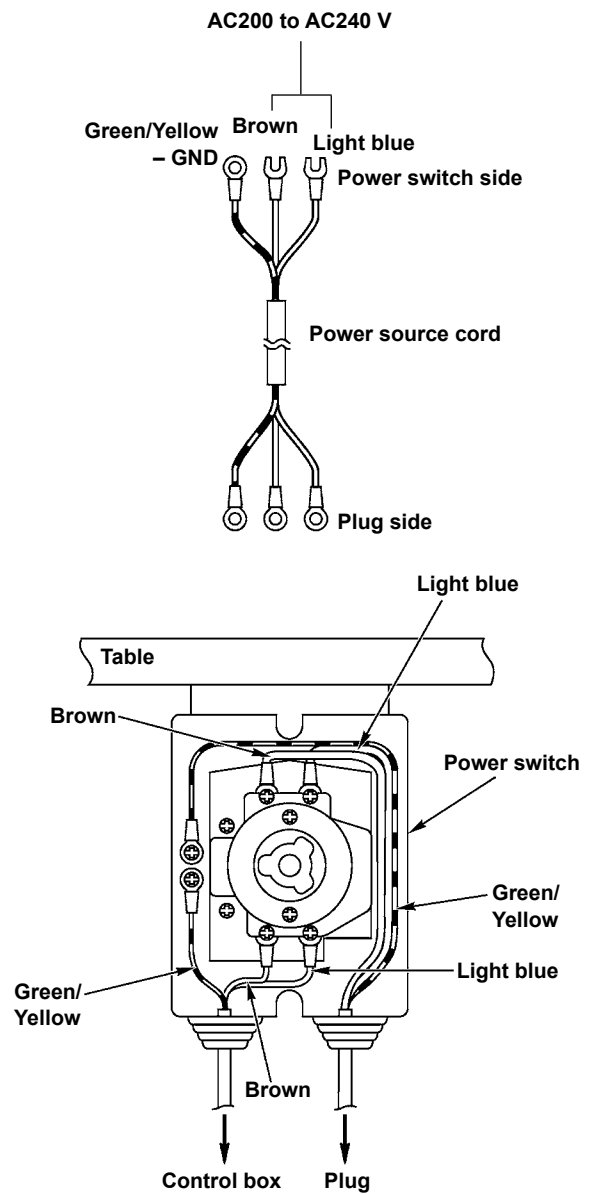
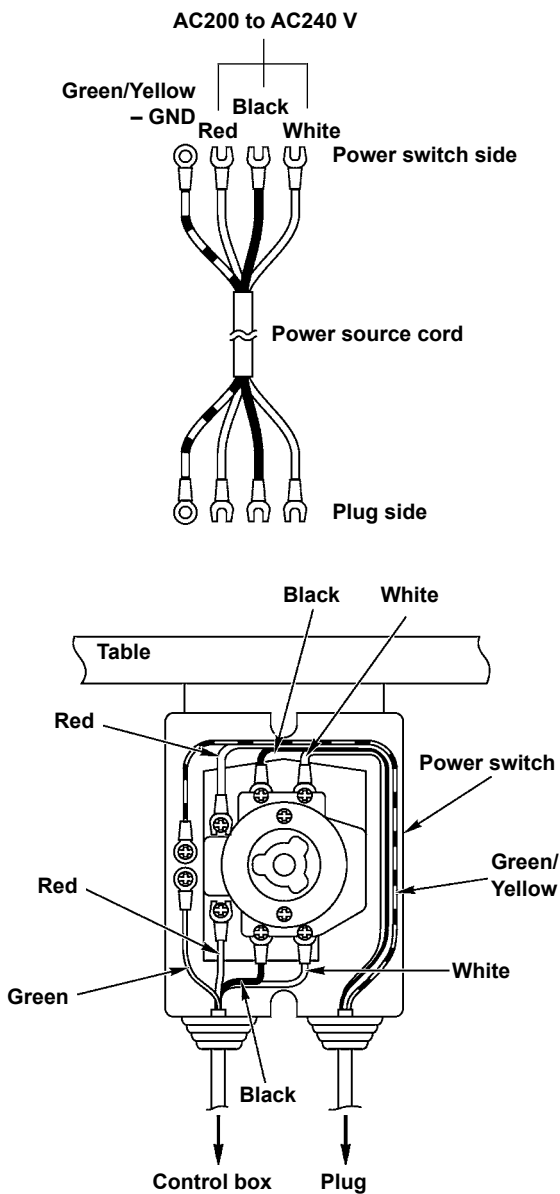

3-4. Taking out the sewing machine

DANGER :



1. The sewing machine should be taken out by a trained technician(s).
2. The sewing machine has a mass of approximately 110 kg. Four or more workers are required to take out the sewing machine.
3. Do not apply an unreasonable force to the sewing machine until the installation of the sewing machine is completed. If such a force is applied, the sewing machine can lose its balance and can fall alone or together with the table, resulting in personal injury or sewing-machine breakage.
4. Never connect the power plug until the installation of the sewing machine is completed in order to protect against an accident due to an abrupt startup of the sewing machine.

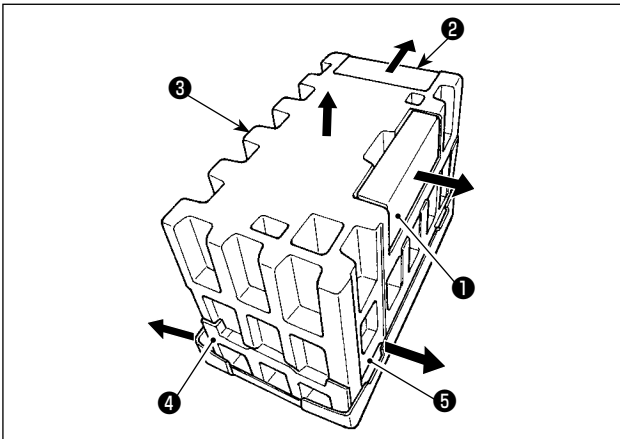

- 1) Remove accessory boxes ① and ② in the direction of the arrow.
- 2) Remove upper foam polystyrene ③ in the direction of the arrow.
- 3) Remove the right and left intermediate foam polystyrene ④ and ⑤ in the direction of the arrow.

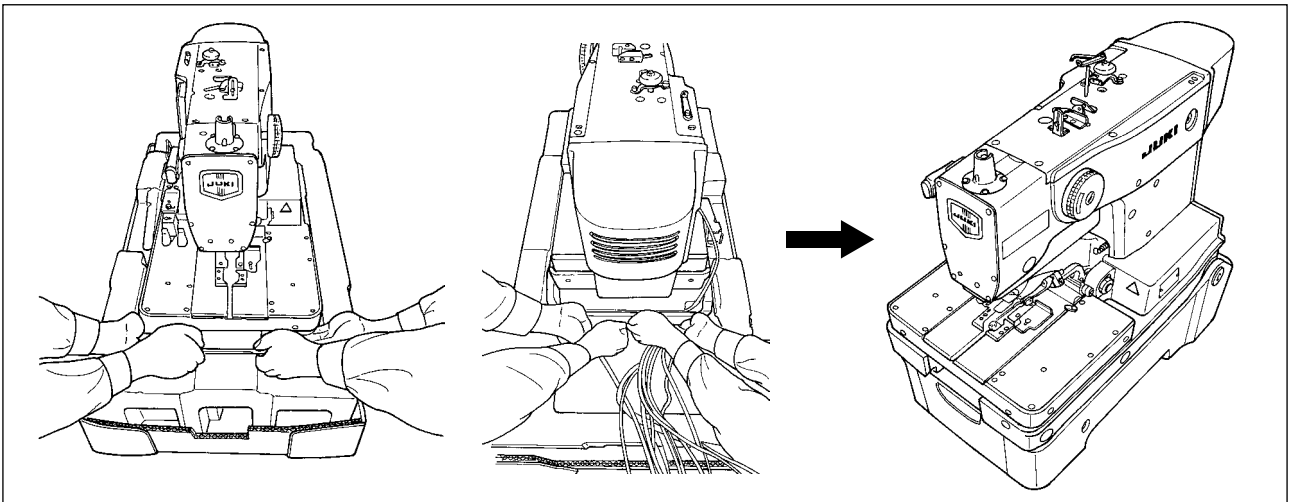

- 4) Take out the sewing machine from the package, by four workers, holding the portions illustrated in the figure. Place it on the floor.

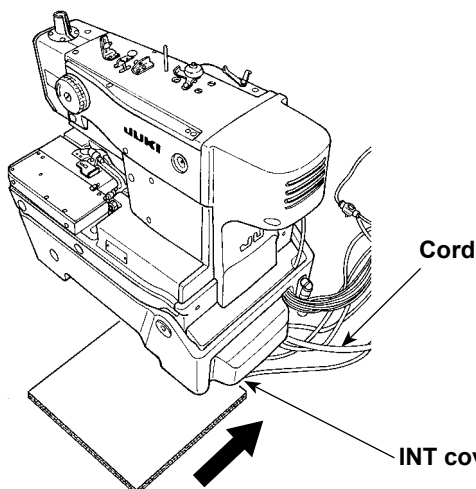

Place a cardboard sheet or packing material between the floor and the sewing machine in order to avoid damaging the floor and to prevent the cords from being pinched between the INT cover and the floor.

3-5. Installing the sewing machine



WARNING :

The sewing machine has to be carried by four or more workers.
Carry out the installation work on a level place.

(1) In the case of the table-fixed type machine head

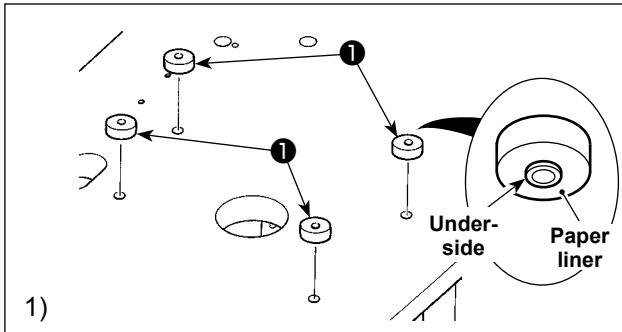

- 1) Remove the paper liners from four bolt rubbers B
①. Place and adhere the liners over the holes in the table. (Place the bolt rubber B with its convex side faced downward.)

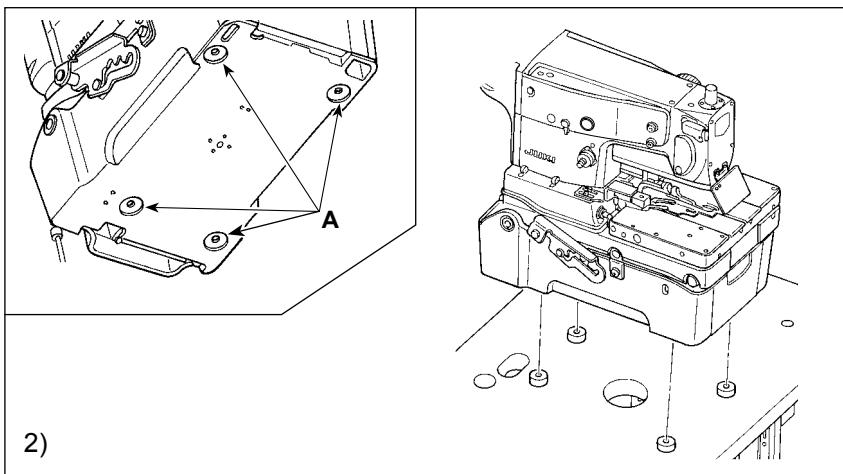

- 2) Place the sewing machine on the top surface of the table in such a way that the concave sections A of the bottom cover fit on bolt rubbers B ①.
- 3) Remove four setscrews ⑨. Remove INT cover ⑩.
- 4) Put air tubes and cords coming from the sewing machine head into the hole in the table.
- 5) Install INT cover ⑩ with four setscrews ⑨.

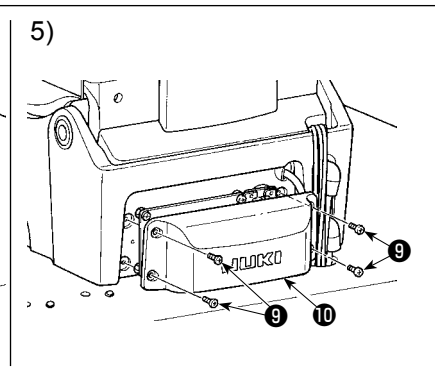
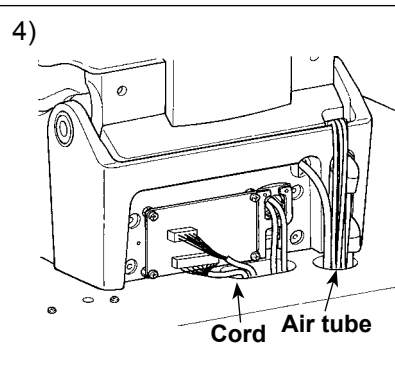
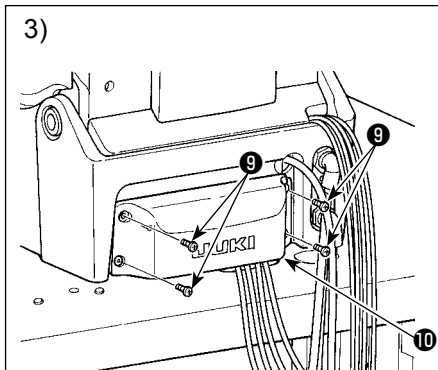

1. Lift the sewing machine head with four or more people by holding the sections marked with dotted circle as shown in the figure.
2. Do not hold the underside of hinge stopper, bottom cover, and feed base.

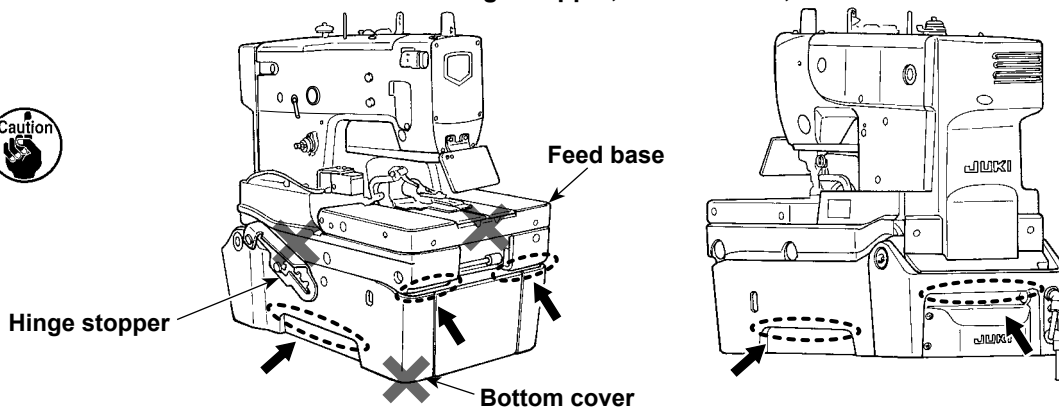

6), 7)

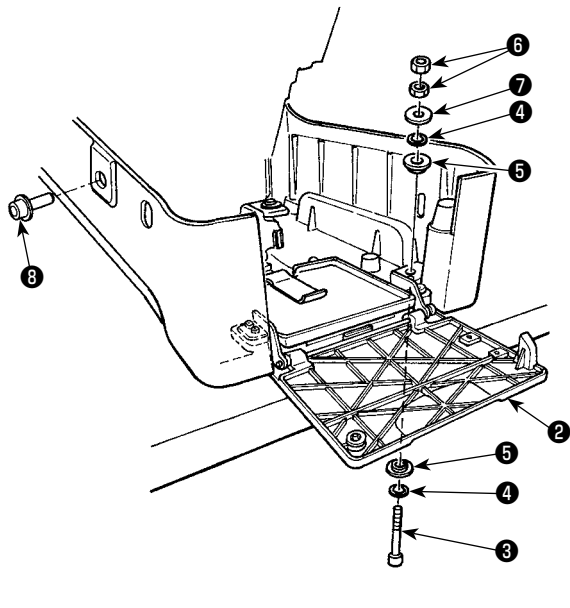

- 6) Remove machine head fixing bolts **8**. Raise the sewing machine to the 1st step of the hinge stopper.
When raising the sewing machine, refer to **"3-6. Raising and returning the sewing machine" p. 16.**

WARNING :



Do not raise the sewing machine above the 1st step of the hinge stopper. If it is raised above the 1st step, the sewing machine can fall, resulting in personal injury or sewing machine breakage.

- 7) Open front cover **2**. Insert a bolt **3**, a washer **4** and a bolt rubber **5** from the right front side of the sewing machine, and temporarily fix them with a bolt rubber **5** a washer **4**, a packing **7** and two nuts **6**.

8) to 10)

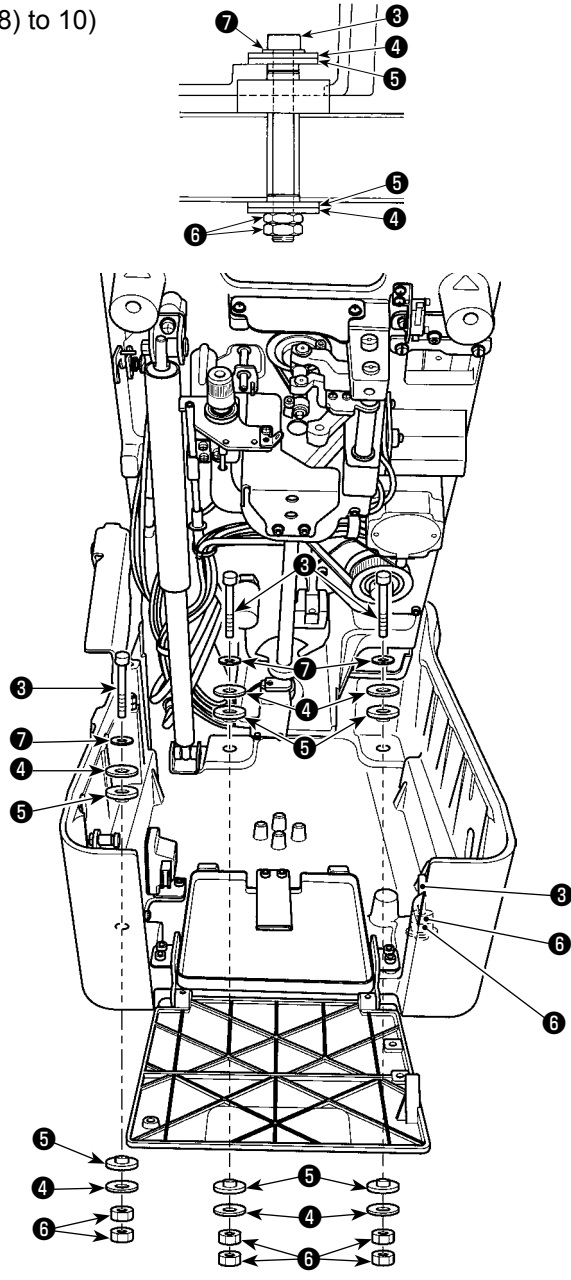

- 8) Be sure to raise the sewing machine to the fourth step of the hinge stopper.
Fix the sewing machine with remaining three bolts **3**, six washers **4**, six bolt rubbers **5**, three packings **7** and six nuts **6**.
- 9) Remove bolt **3** and two nuts **6** which have been used for temporarily fixing.

WARNING :



If your body comes in contact with the corner section of connector cover **9** of the lateral-direction motor during work, unexpected injury can be caused. Be sure to keep away from the corner section of the connector cover.

- 10) Attach bolt **3** and two nuts **6** removed in the above step of procedure in the reverse direction and fix them.



Fix bolt **3** and nuts **6** in such a state that bolt rubber **5** is slightly squeezed.



1. Keep machine head fixing bolt **8** since it is necessary when moving the sewing machine. Whenever you move the sewing machine, be sure to install the head fixing bolt in place.
2. Bolt **3** is an M8 hexagon socket head bolt (length: 85 mm). Nut **6** is an M8 one.

(2) In the case of the semi-sunken type machine head

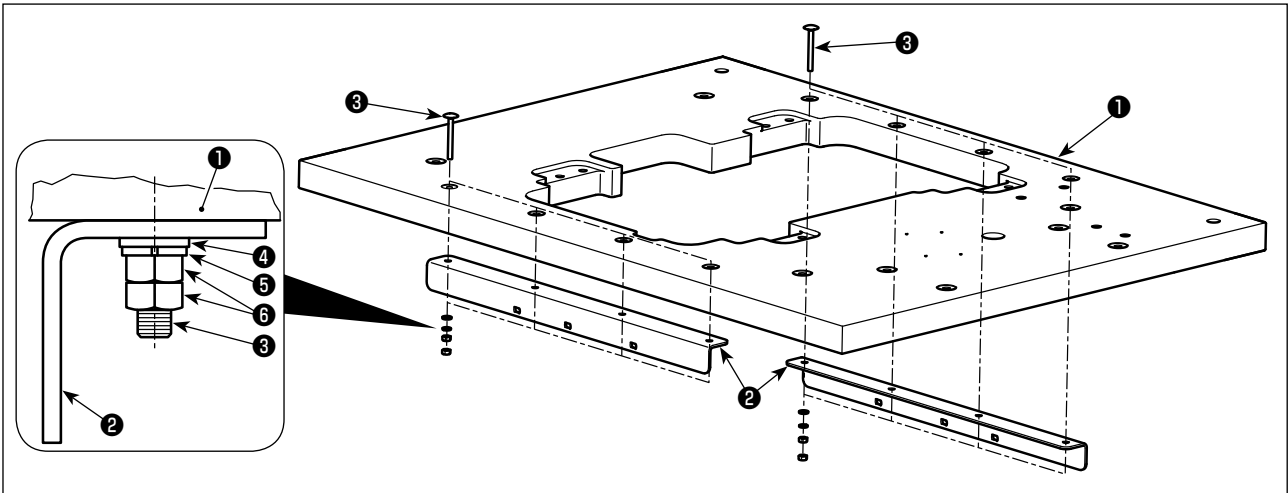

① Installing the table reinforcing plate

- 1) Fix two table reinforcing plates **2** on the table **1** with eight bolts **3**, eight plain washers **4**, eight spring washers **5** and 16 nuts **6**.



The bolt **3** is M6 carriage bolt length of which is 60 mm. The dimensions of the plain washer **4** are "φ12.5 × φ6.4 × t1.6". Spring washer **5** is for M6 and nut **6** is M6 (class 1). Bolts **3**, plain washers **4**, spring washers **5** and nuts **6** are supplied with the kit for semi-sunken type machine head (part number: 40157881).

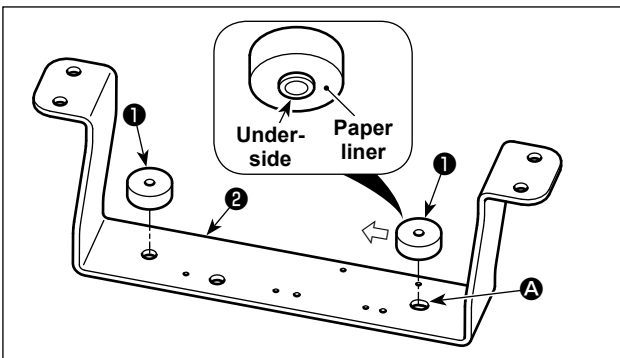

② Assembling the bottom cover stay (front)

- 1) Remove paper liners **3** from two bottom rubbers B **1** and affix them on bottom cover stay **2**.
- * Affix two right-side bottom rubbers B **1** with shifted to the left side (in the direction of the arrow) with respect to slot **A** in bottom cover stay **2**.

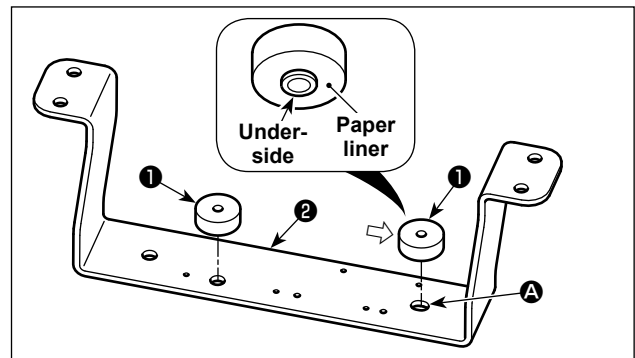

③ Assembling the bottom cover stay (rear)

- 1) Remove paper liners **3** from two bottom rubbers B **1** and affix them on bottom cover stay **2**.
- * Affix two right-side bottom rubbers B **1** with shifted to the right side (in the direction of the arrow) with respect to slot **A** in bottom cover stay **2**.



1. Insert bottom rubbers B **1** into the respective holes in bottom cover stay **2** while holding them so that their projecting side is faced downward.
2. Carefully check the location of mounting holes in left-side bottom rubbers B **1**.



Bolt rubber B **1** is the head accessories. In addition, bottom cover stay **2** are supplied with the kit for semi-sunken type machine head (part number: 40157881).

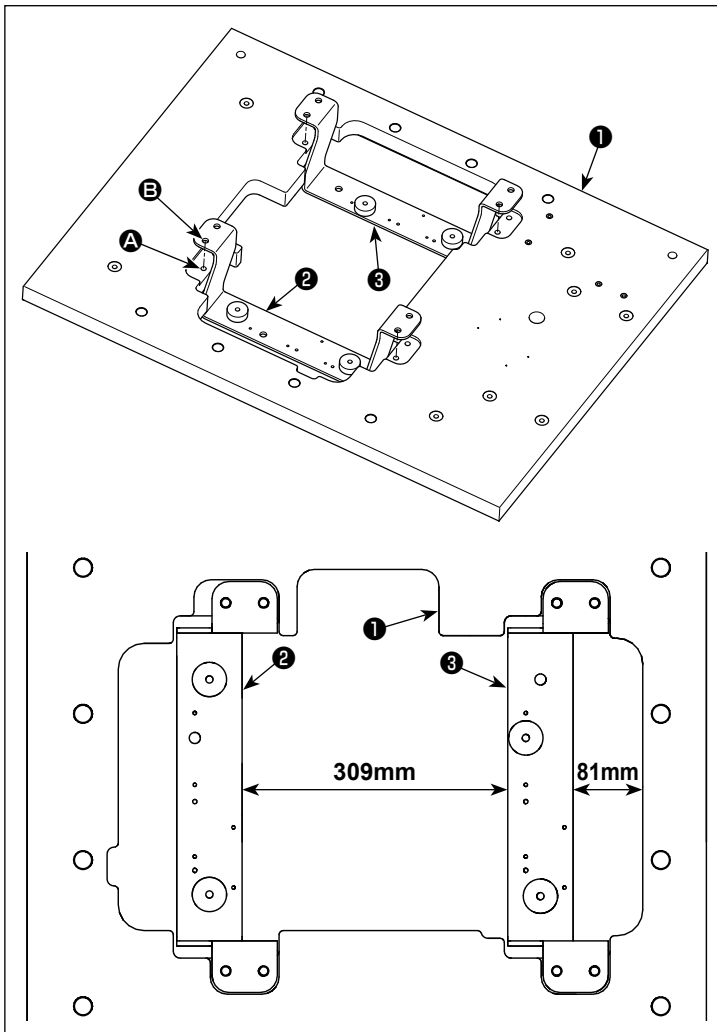

④ INSTALLATION

- 1) Place table ①, bottom cover stay (front) ② and bottom cover stay (rear) ③ on the floor.
- 2) Align bottom cover stay mounting hole ④ in table ① with mounting holes ⑤ for the respective bottom cover stays.

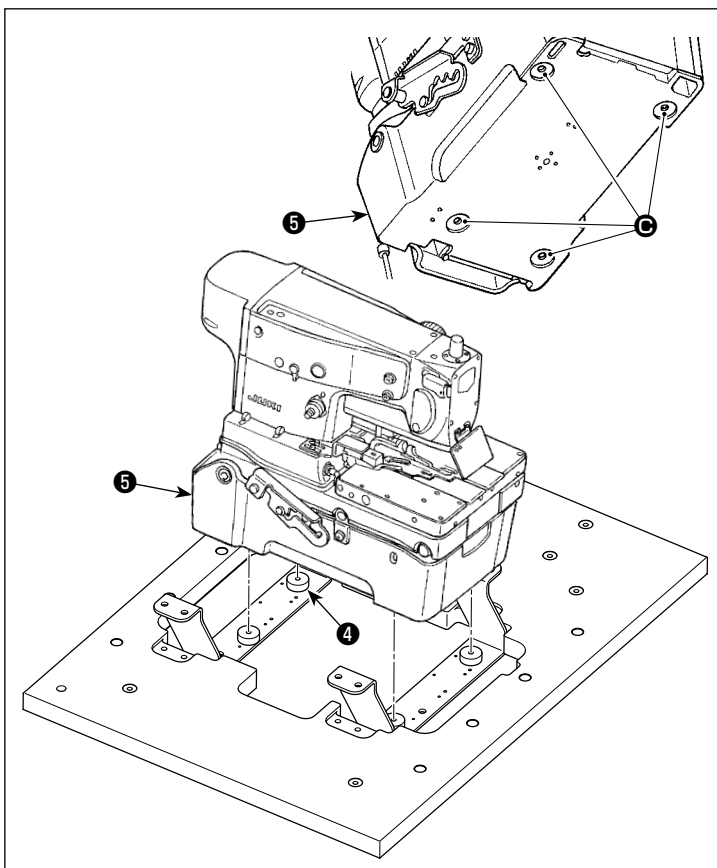

At this time, the distance between the respective bottom cover stays must be 309 mm, and the distance between bottom cover stay (rear) ③ and table ① must be 81 mm.



- 3) Put the machine head on the bottom cover stays.
At this time, put the machine head in such a way that bottom rubber B ④ fits in depressed portions ⑥ in bottom cover ⑤.

* Refer also to the precautions given on the next page.

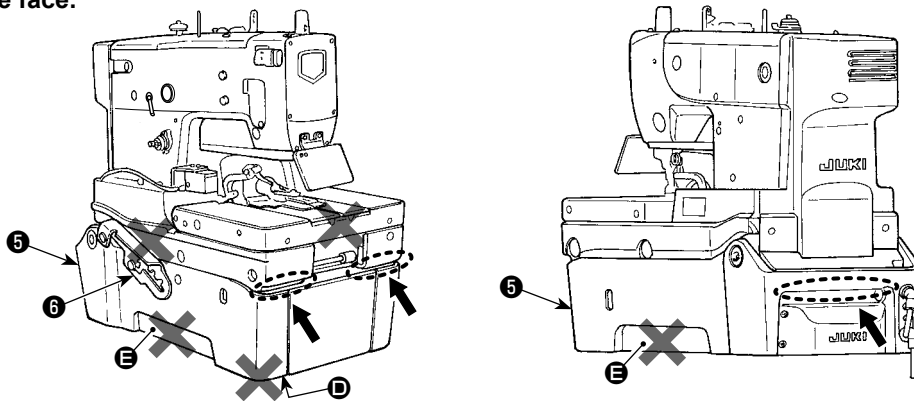
1. Lift the sewing machine head with four or more people by holding the sections marked with dotted circle as shown in the figure.
2. Do not hold hinge stopper ⑥, bottom ⑤ of bottom cover ④ and depressed portion ③ on the side face.



3. When placing the machine head on the table or lifting the table, take care not to allow handle ⑦ and INT cover ⑧ to hit against table ①. In addition, do not place the wiring and piping between INT cover ⑧ and table ①.

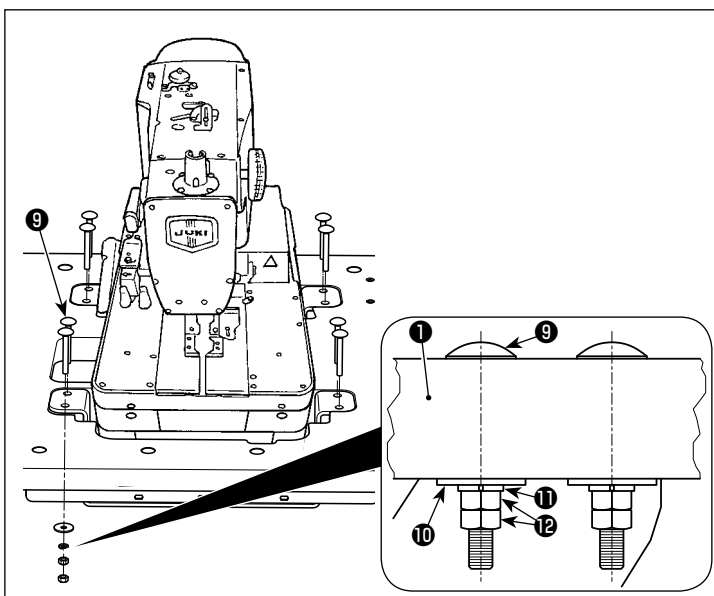
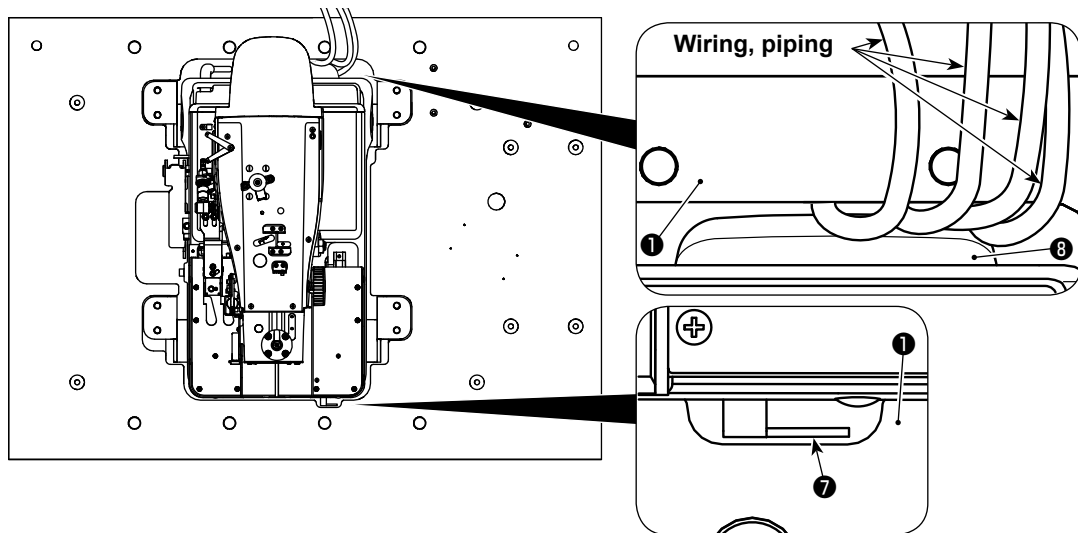

- 4) Lifting table ①, join table ①, bottom cover stay (front) ② and bottom cover stay (rear) ③ with eight bolts ⑨, eight plain washers ⑩, eight spring washers ⑪ and 16 nuts ⑫.

The bolt ⑨ is M8 carriage bolt length of which is 70 mm. The dimensions of the plain washer ⑩ are "φ30 × φ8.5 × t2". Spring washer ⑪ is for M8 and nut ⑫ is M8 (class 1).



Bolts ⑨, plain washers ⑩, spring washers ⑪ and nuts ⑫ are supplied with the kit for semi-sunken type machine head (part number: 40157881).

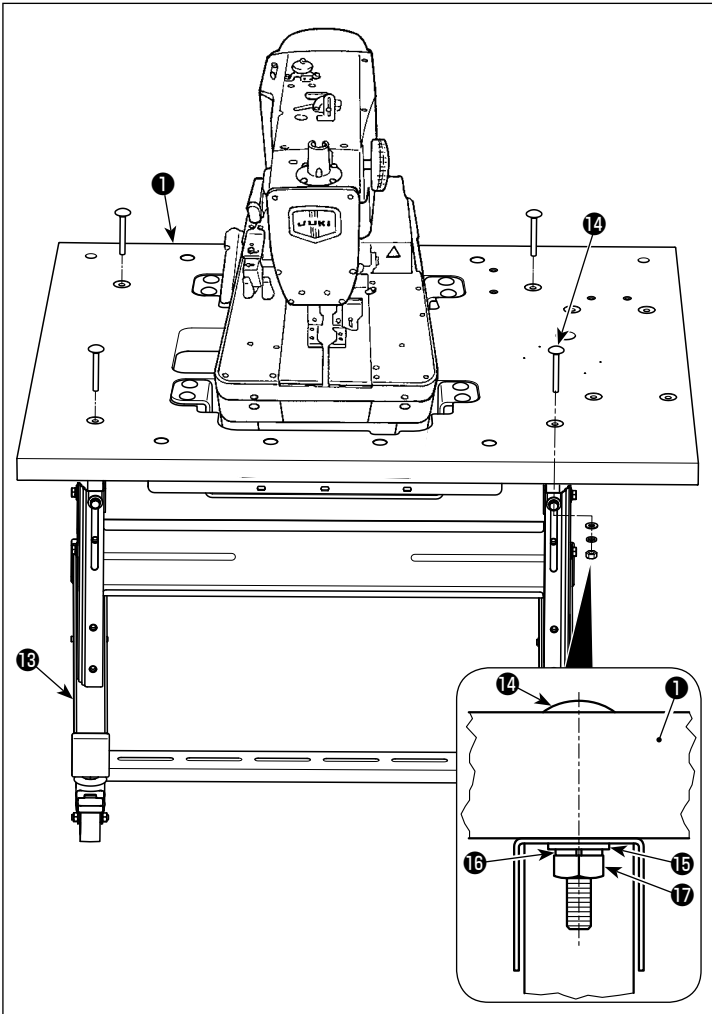

- 5) Holding table ① at its four corners with four or more workers, place it on assembled table stand ⑬ and fix with four bolts ⑭, four plain washers ⑮, four spring washers ⑯ and four nuts ⑰.



1. Lift the table ① has to be carried by four or more workers.
2. Lift the table ① while keeping it in a horizontal position without tilting.



Bolt ⑭ is carriage bolt with 18 5/16 threads and is 70 mm long. Plain washer ⑮ is of "φ18 × φ8.5 × t1.6". Spring washer ⑯ is of "φ15 × φ9 × t2". Nut ⑰ has 18 5/16 threads. Bolt ⑭, plain washer ⑮, spring washer ⑯, nut ⑰ is the head accessories.

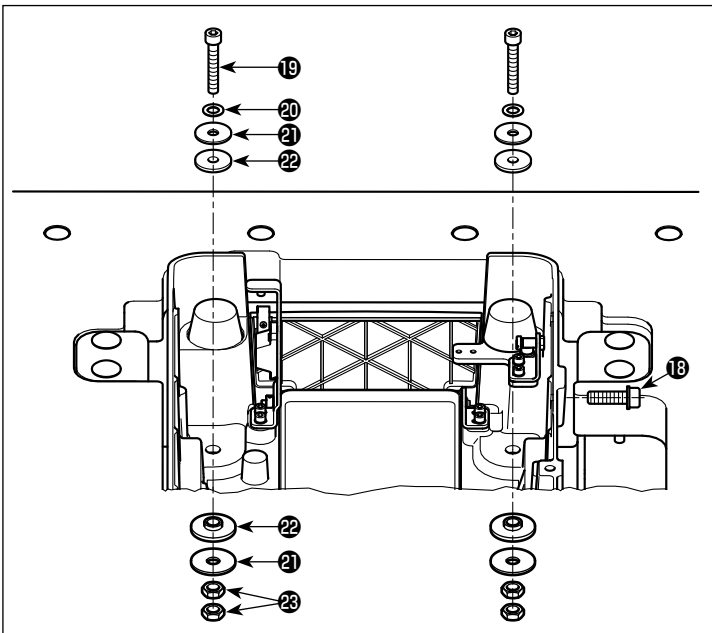

- 6) Remove machine head fixing bolts ⑱. Raise the sewing machine to the 3rd step of the hinge stopper. When raising the sewing machine, refer to ["3-6. Raising and returning the sewing machine" p. 16.](#)
- 7) Secure the machine head by fixing two bolts ⑲, two packings ⑳, four plain washers ㉑, four bolt rubbers ㉒ and four nuts ㉓ at two locations on this side of the sewing machine.



Fix bolt ⑲ and nuts ㉓ in such a state that bolt rubber ㉒ is slightly squeezed.

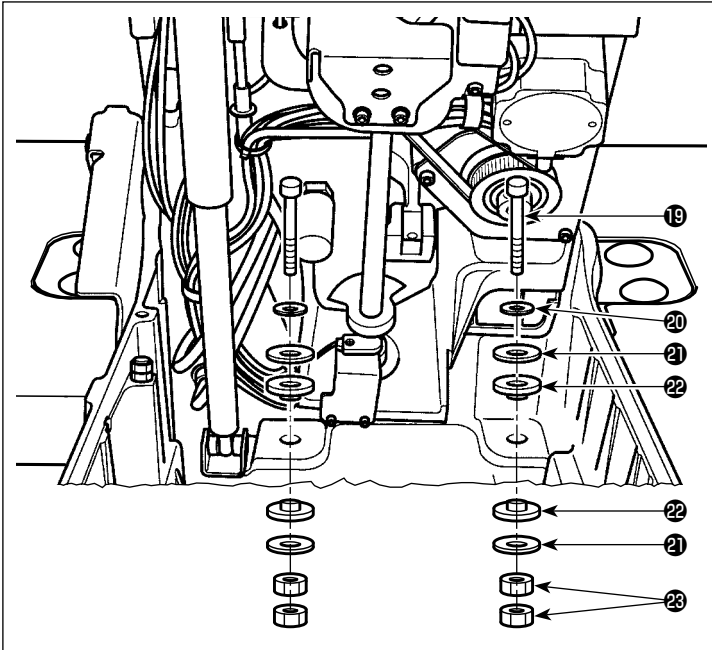

8) Raise the sewing machine to the 4th step of the hinge stopper.

When raising the sewing machine, refer to **"3-6. Raising and returning the sewing machine" p. 16.**

9) Secure the machine head by fixing two bolts 19, two packings 20, four plain washers 21, four bolt rubbers 22 and four nuts 23 at two locations on far side of the sewing machine.



Fix bolt 19 and nuts 23 in such a state that bolt rubber 22 is slightly squeezed.



1. Keep machine head fixing bolt 19 since it is necessary when moving the sewing machine. Whenever you move the sewing machine, be sure to install the head fixing bolt in place.
2. The bolt 19 is M8 hexagon socket head screws of which is 50 mm. The dimensions of the plain washer 21 are "φ30 × φ8.5 × t2" and nut 23 is M8 (class 3).
Bolt 19, packing 20 plain washer 21, bolt rubber 22, nut 23 is the head accessories.

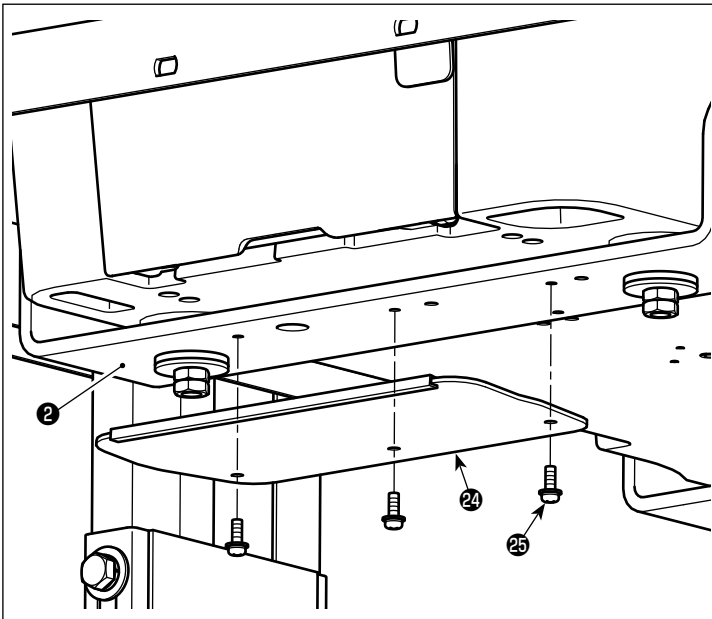

10) Secure tray 24 on bottom cover stay (front) 2 with three setscrews 25.



Setscrew 25 is an M4 round head screw with washer and has a length of 12 mm.
Tray 24 and setscrews 25 are supplied with the kit for semi-sunken type machine head (part number: 40157881).

3-6. Raising and returning the sewing machine

DANGER :

1. Do not lift the sewing machine for any purpose other than for installation, repair or adjustment in order to prevent accidents resulting in personal injuries due to pinching. In addition, the sewing machine has to be lifted for repair or adjustment only by a maintenance technician who is familiar with the machine.

2. If you find the sewing machine is too heavy to lift, the gas spring may have malfunctioned due to outgassing.

Never lift the sewing machine in such a state since the machine can drop to pinch hands, fingers and arms resulting in serious injury.



* Carefully read the description given in "10-14. (6) Standard of replacing time of the gas spring" p.110 and "10-14. (7) Replacing the gas spring" p.111.

3. Be sure to carry out the work while strictly observing the following in order to protect against serious injury to hands, fingers and/or arms due to pinching in the relevant parts of the sewing machine.

- Be sure to hold the sewing machine by the ribs located on the front side of the bed.

- Be sure to securely fix the sewing machine in the raised position by locking the hinge stopper.

4. Do not hold any part other than the ribs located on the front side of the bed.

5. If you raise the sewing machine with the feed base remained on this side, the feed base can move to pinch hands and fingers resulting in an unexpected injury.

WARNING :



When raising/returning the sewing machine from/to its home position, check to be sure that the sewing machine is locked by the support shaft in the stop position of each step of the hinge stopper.

The sewing machine can be raised/returned to/from four different heights.

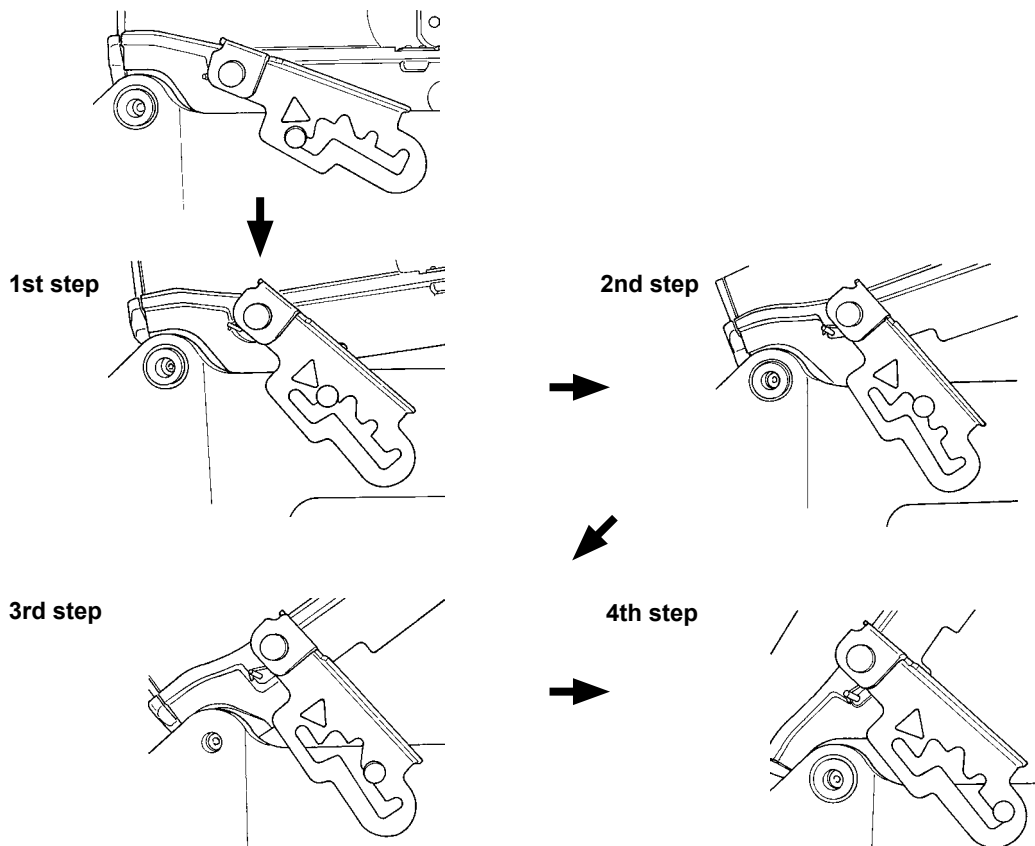

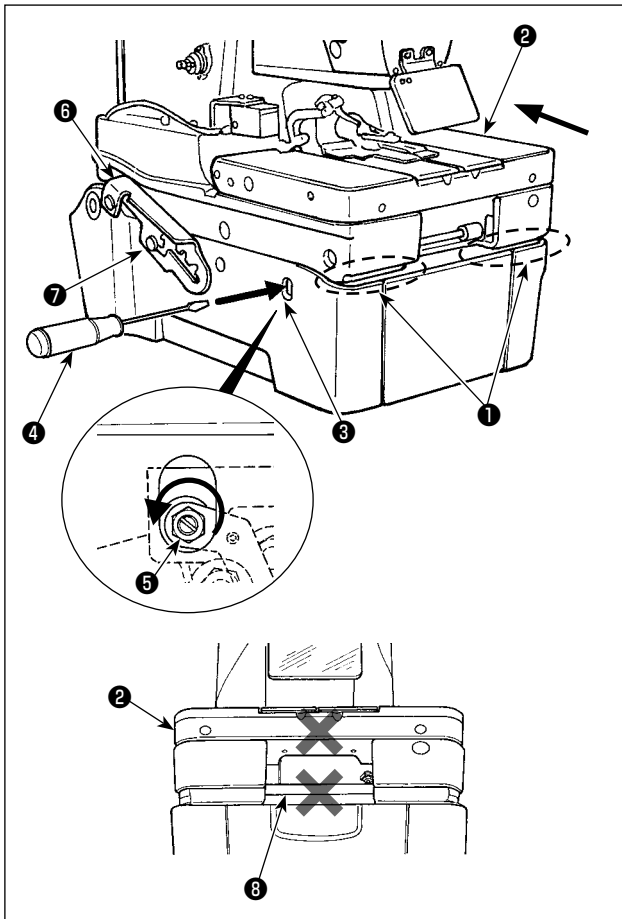

- 1) To raise the sewing machine, firstly push feed base **2** away from you (in the direction of the arrow), then insert flat-blade screwdriver **4** into bottom-cover opening tool slot **3**, turn it counter-clockwise to release the sewing machine up/down lock **5**.
- 2) Turn flat-blade screwdriver **4** to keep the lock in the released state, and slightly lift the sewing machine by holding it by rib **1** located on the front side of the bed.
- 3) Carefully remove flat-blade screwdriver **4**. Hold ribs **1** located on the front side of the bed with your both hands to slowly lift the sewing machine to the 1st step of hinge stopper **6**.
At this time, do not hold feed base **2** and feed guide shaft **8**.
- 4) Check to be sure that hinge stopper **6** is locked by support shaft **7**. Then, take hands off the ribs.
- 5) To raise the sewing machine to the 1st to 3rd steps of the hinge stopper, hold ribs **1** located on the front side of the bed with your both hands to slowly lift it to the required step of the hinge stopper.

[To lift the sewing machine from the 3rd to 4th step of the hinge stopper]

- 6) Hold rib ① located on the front side of the bed with your right hand to draw hinge stopper ⑥ in direction of arrow A until the lock is released. Then, slowly lift the sewing machine.
- 7) Hold ribs ① located on the front side of the bed with your both hands to slowly lift the sewing machine to the 4th step of hinge stopper ⑥.

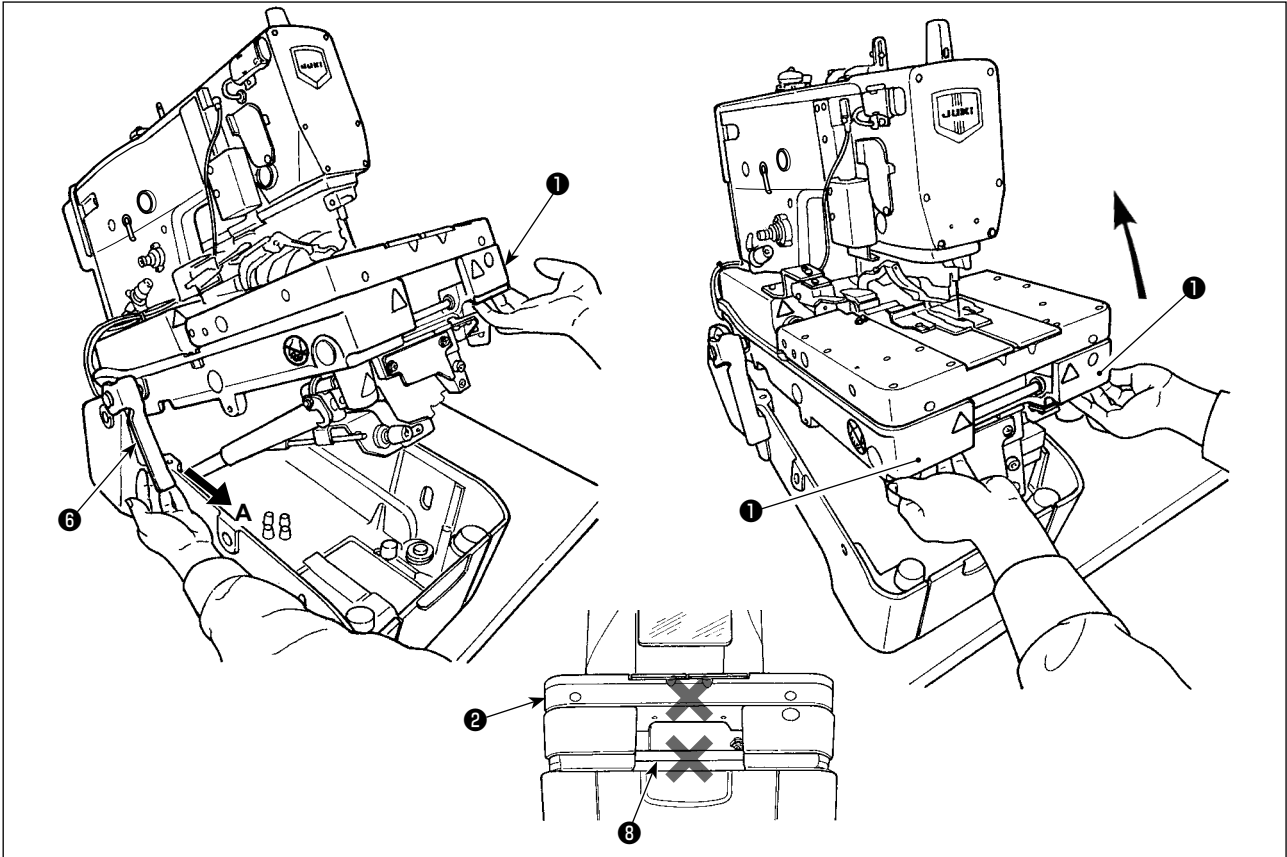

- 8) To return the sewing machine to its home position, firstly check to be sure that there is no tool such as a screwdriver inside the bottom cover.
- 9) Hold rib ① located on the front side of the bed with your right hand to slightly lift the sewing machine. Then, hold handle ⑥ of the hinge stopper with your left hand and pull it toward you (in direction A) until the lock is released, then slowly lower the sewing machine.
- 10) Take your left hand off the stopper section. While supporting ribs ① located on the front side of the bed with your both hands, lower the sewing machine further.

DANGER :



1. Do not lower the sewing machine while keeping pulling the hinge stopper in direction A, in order to prevent pinning of fingers, hands and arms under the sewing machine leading to a serious injury. (Be sure to take your hands off the hinge stopper.)
2. Do not hold feed base ② and feed guide shaft ③.

- 11) At its each step, the hinge stopper is locked to secure the sewing machine at the corresponding height. Following the procedure described in 9), hold rib ① on the front side of the bed with your right hand to slightly lift the sewing machine. Then, hold the handle of the hinge stopper with your left hand to release the lock and slowly lower the sewing machine.
- 12) The sewing machine is stopped again at the final step of its lowering for the sake of safety. Following the procedure described in 9), hold rib ① on the front side of the bed with your right hand to slightly lift the sewing machine. Then, hold the handle of the hinge stopper with your left hand to release the lock and slowly lower the sewing machine.

DANGER :



Take care to prevent pinching of hands and fingers between the sewing machine and the bottom cover. It should be strictly prohibited to lower the sewing machine by two or more workers while holding it by any section other than the ribs located on the front side of the bed since it can cause a pinching accident resulting in a serious injury to hands, fingers and/or arms.

3-7. Installing the poly oiler

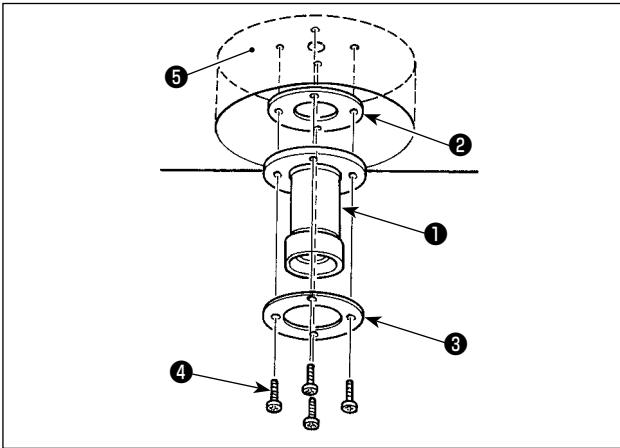

- 1) Place the sewing machine in its home position.
- 2) Install oil drain cock ①, oil seal ② and washer ③ on bottom cover ⑤ with four setscrews ④.
- 3) Raise the sewing machine.

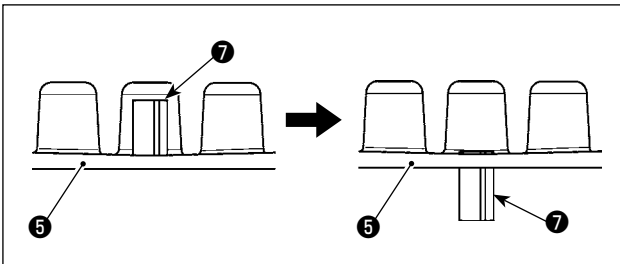

- 4) Drive spring pin ⑦ of bottom cover ⑤ into bottom cover ⑤ until it is almost flush with bottom cover ⑤.



Take care not to crack bottom cover ⑤ when driving in spring pin ⑦.

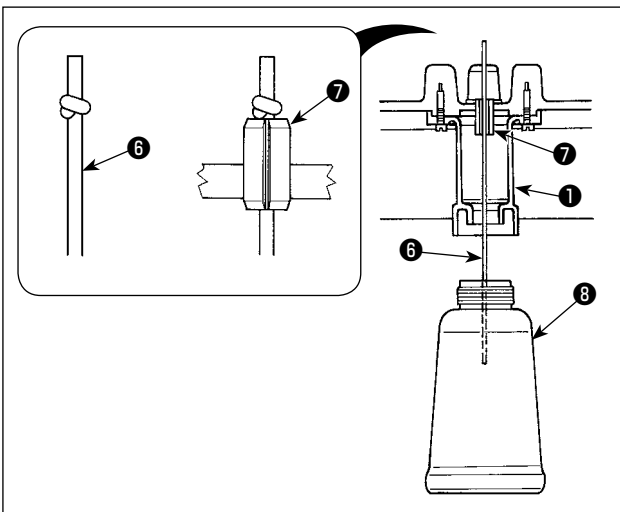

- 5) Make a knot in the oil wick ⑥ (ø2.5 mm). Insert oil wick ⑥ (ø2.5 mm) into spring pin ⑦ of bottom cover ⑤ until its end comes from oil drain cock ①. At this time, insert oil wick ⑥ (ø2.5 mm) supplied as accessories into the slit in spring pin ⑦.
- 6) Install poly oiler ⑧ on oil drain cock ①.



Refer to "3-6. Raising and returning the sewing machine" p. 16 when you raise or return the sewing machine.

3-8. Installing the operation panel

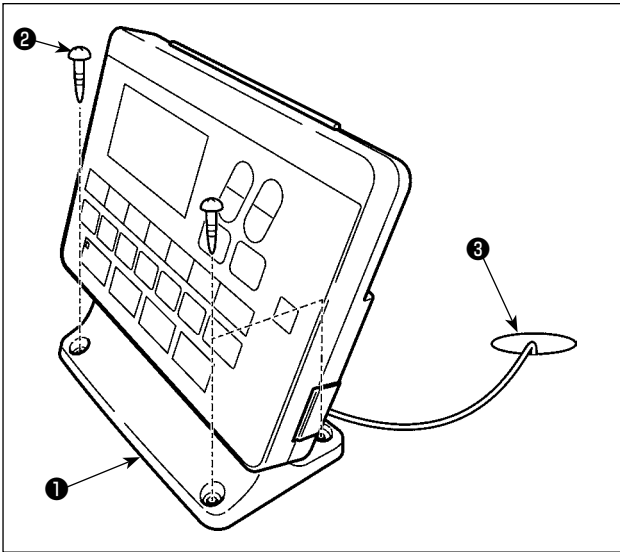

- 1) Fix operation panel mounting plate **1** on the table with four wood screws **2**. Then, pass the cable through hole **3** in the table.

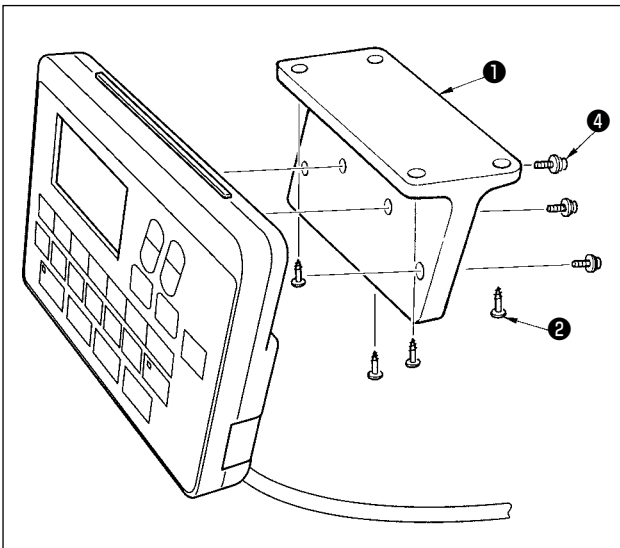

- 2) In the case of installing the operation panel on the underside of the table, install the operation panel on panel mounting plate **1** by tightening screws **4** in four mounting holes. Then, fix the panel mounting plate at a desired position on the underside of the table with four wood screws **2**.

3-9. Installing the regulator and the manifold

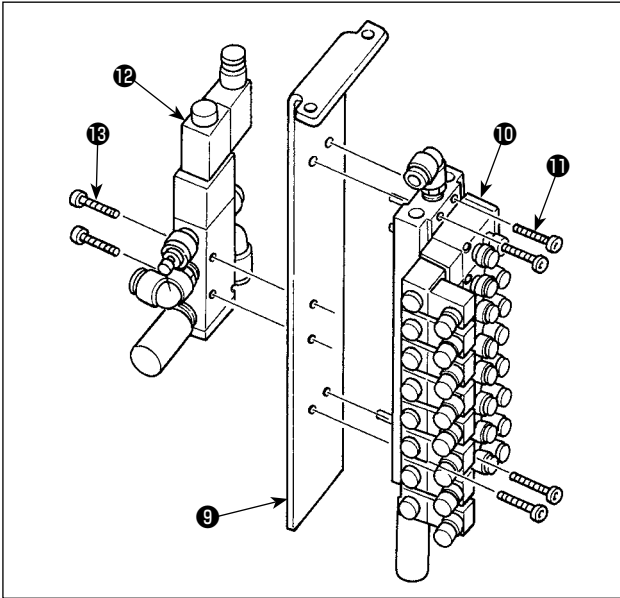

- 1) Install manifold asm. **10** on manifold mounting plate **9** with four setscrews **11**.
- 2) Install solenoid valve **12** on manifold mounting plate **9** with two setscrews **13**.

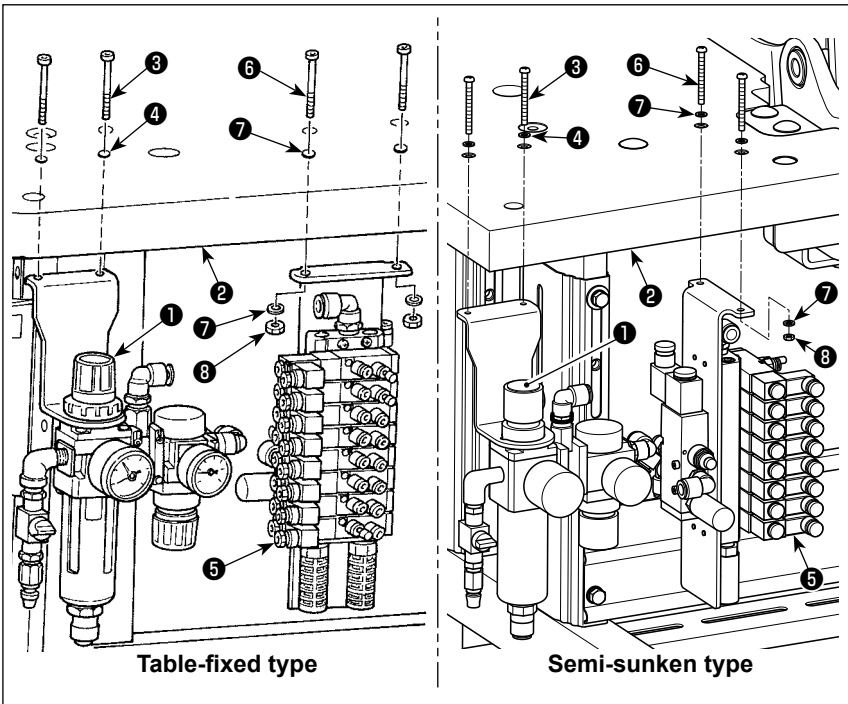

- 3) Install regulator asm. **1** on table **2** with two setscrews **3** and two washers **4**.
- 4) Install manifold **5** on table **2** with two setscrews **6**, four washers **7** and two nuts **8**.

Setscrews **3** and **6** are pan head screws M5 of length 50 (mm). Setscrews **11** and **13** are hexagon socket head screws M4 of length 30. Nuts **8** are hexagon nuts M5.

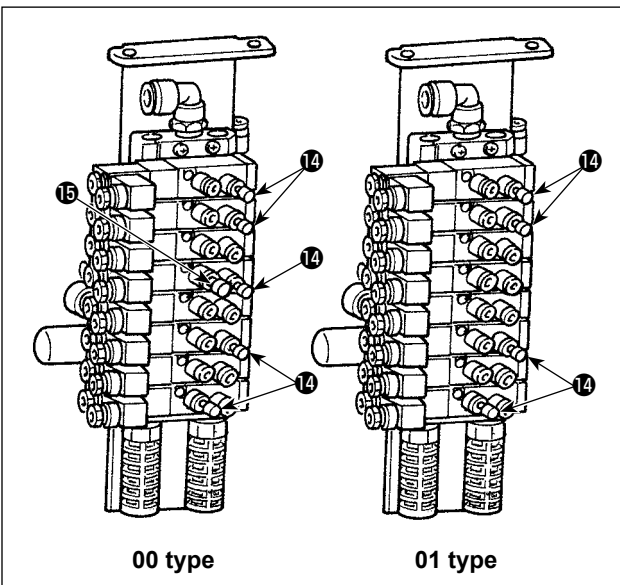

- 5) Attach plugs **14** and **15** to manifold asm. **10** at the locations shown in the figure at left.

Plug **14** is for $\varnothing 4$ hole and plug **15** is for $\varnothing 6$ hole.

[For the needle thread clamp unit]

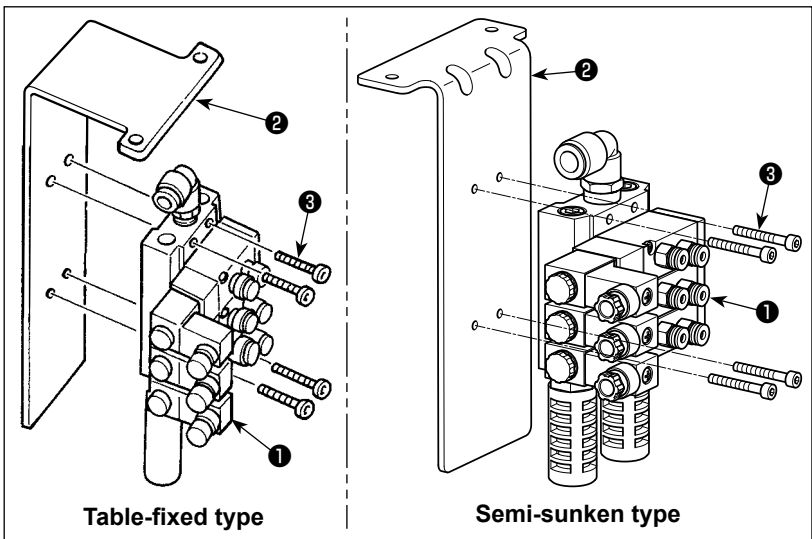

- 1) Install manifold asm. ① for the needle thread clamp on manifold mounting plate ② with four set-screws ③.

Reference Setscrew ③ is M4 hexagon socket head screws of which is 30 mm.

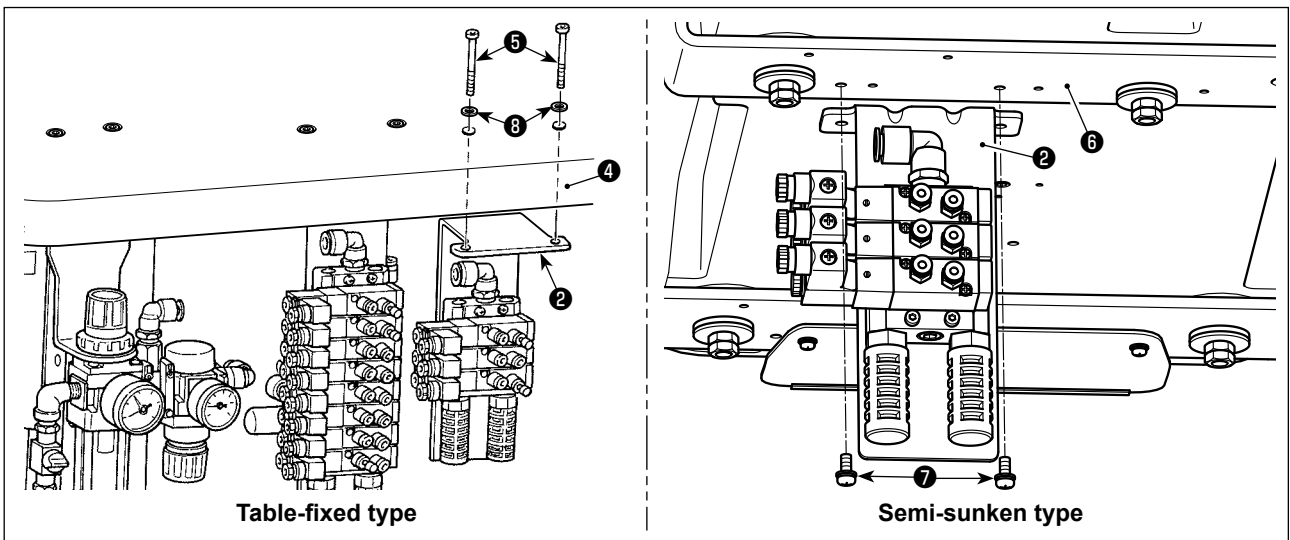

- 2) For the table-fixed type machine head, install manifold mounting plate ② which has been assembled in 1) on table ④ with two setscrews ⑤ and two washers ⑧. For the semi-sunken type machine head, install it on bottom cover stay (rear) ⑥ with two setscrews ⑦.

Reference Setscrew ⑤ is M5 50-mm long pan head screw. Setscrew ⑦ is M5 12 mm long pan head screw with washer.

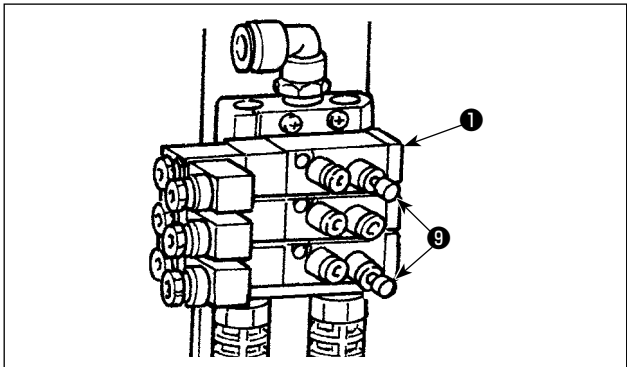

- 3) Attach plug ⑨ to manifold asm. ① for the needle thread clamp at the locations shown in the figure at left.
For one of plugs ⑨, remove No. 39 of the manifold asm. and attach the plug instead. (Pipe is connected to No.39.)

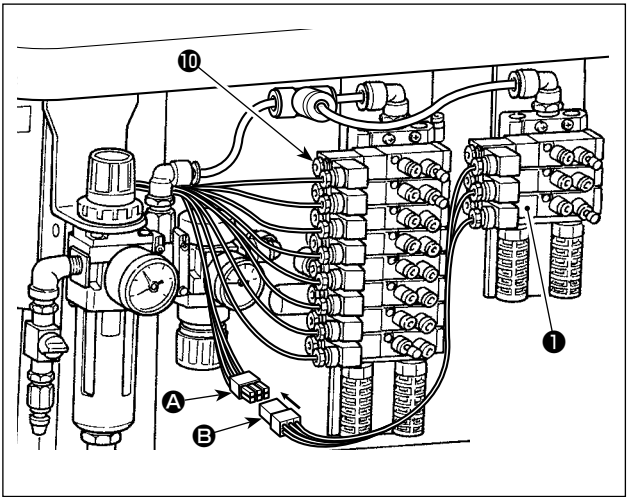

- 4) Connect connector A of standard manifold ⑩ and connector B of manifold asm. ① for the needle thread clamp.

3-10. Connecting the cords



DANGER :

To prevent personal injuries caused by electric shock hazards or abrupt start of the sewing machine, carry out the work after turning OFF the power switch and a lapse of 5 minutes or more. To prevent accidents caused by unaccustomed work or electric shock, request the electric expert or engineer of our dealers when adjusting the electrical components.

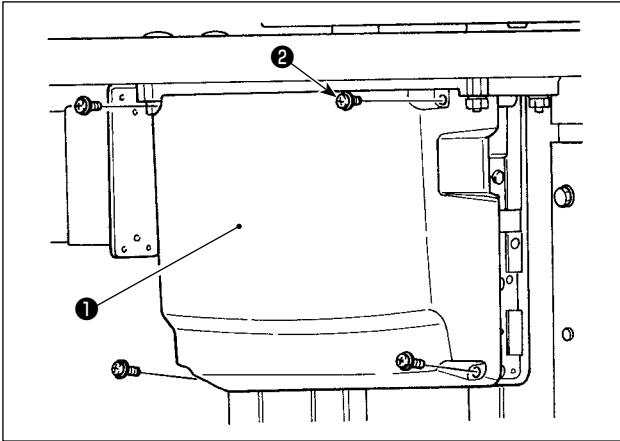

- 1) Loosen four setscrews ② of control box cover ①. Remove control box cover ①.
- 2) Connect the cords to the respective connectors on MAIN PWB, SDC PWB. (Fig. 1)
- 3) Fix the shielded ground wire of the INT PCB signal cord at location A of the control box with a screw. (Fig. 2)

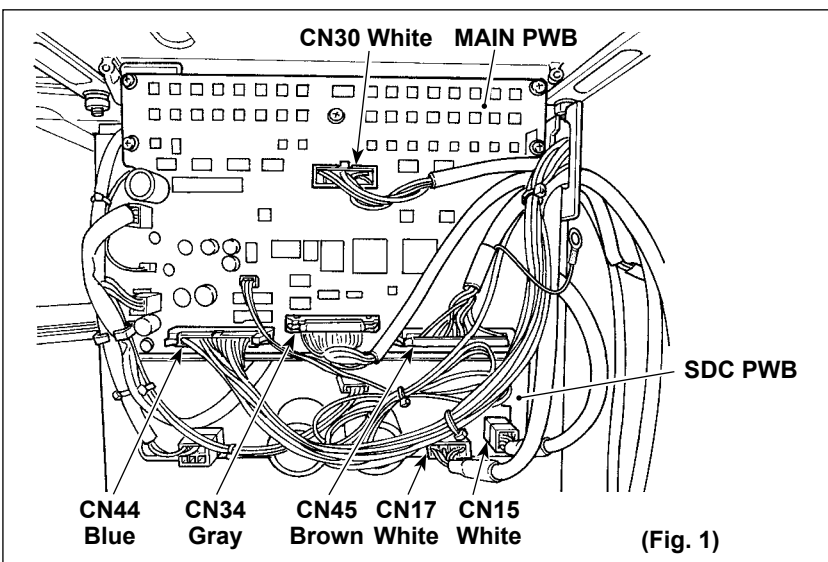
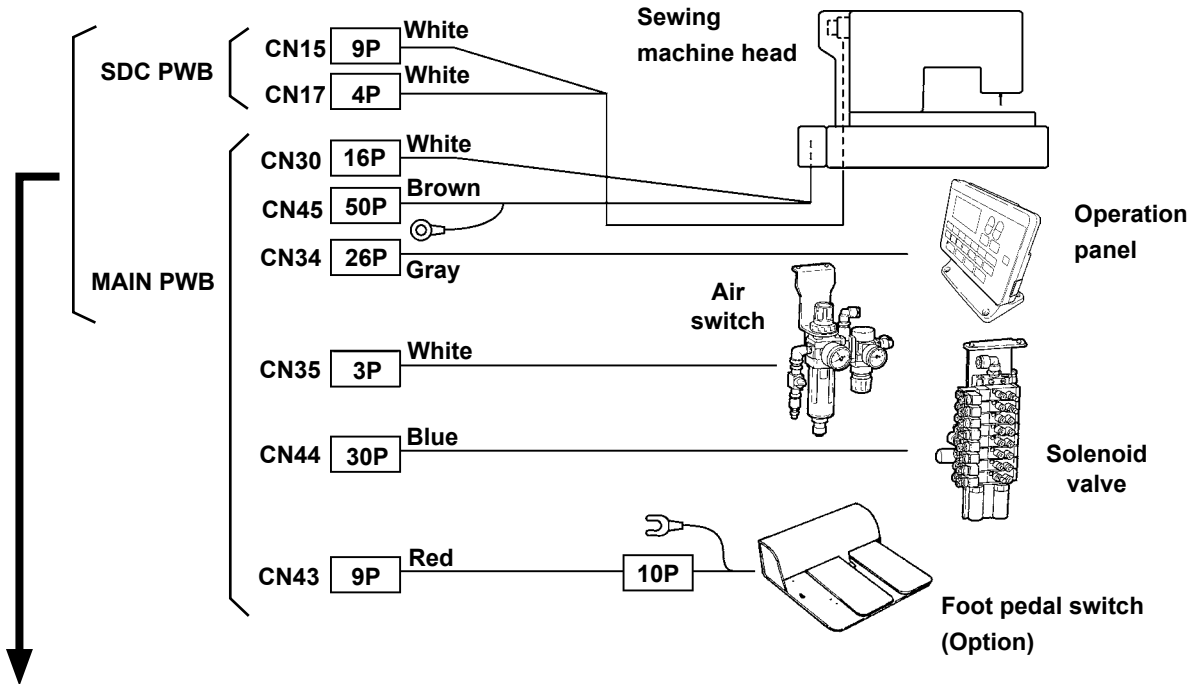

(Fig. 1)

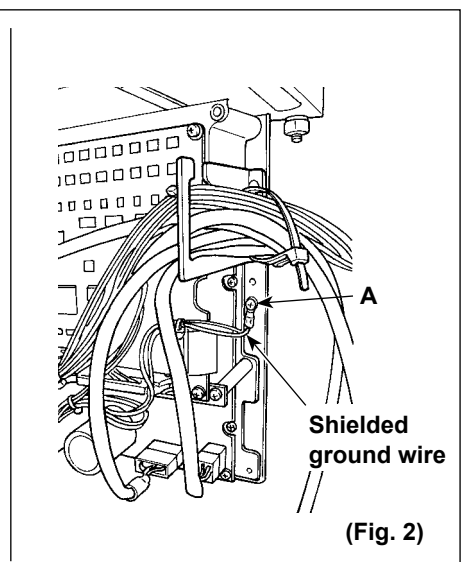

(Fig. 2)

3-11. Handling the cords



DANGER :

To prevent personal injuries caused by electric shock hazards or abrupt start of the sewing machine, carry out the work after turning OFF the power switch and a lapse of 5 minutes or more. To prevent accidents caused by unaccustomed work or electric shock, request the electric expert or engineer of our dealers when adjusting the electrical components.

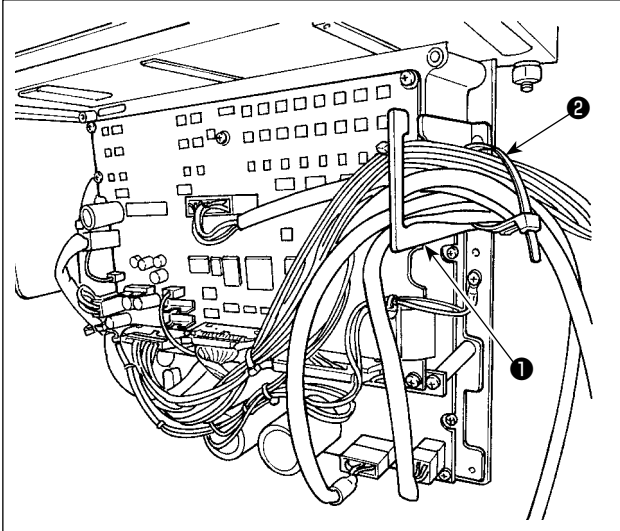

- 1) Bring the cords under the table into the control box.
- 2) Put the cord brought into the control box through cord exit plate ① and fix cable clip band ②.

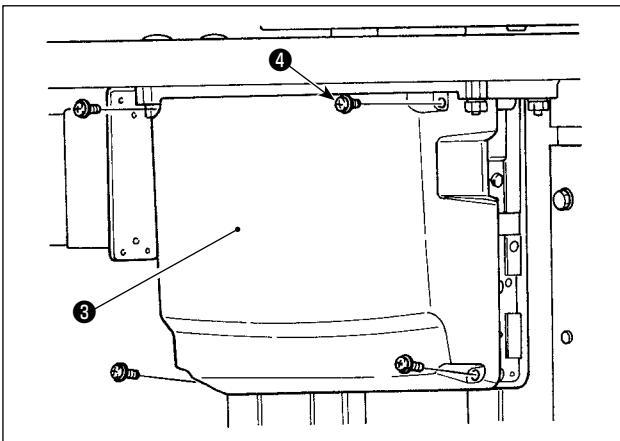

- 3) Install control box lid ③ with four setscrews ④.

3-12. Installing the foot pedal switch (optional)



DANGER :

To prevent personal injuries caused by electric shock hazards or abrupt start of the sewing machine, carry out the work after turning OFF the power switch and a lapse of 5 minutes or more. To prevent accidents caused by unaccustomed work or electric shock, request the electric expert or engineer of our dealers when adjusting the electrical components.

The hand switch is provided on the standard type machine.

To use the optional foot pedal switch (part number: 40033831), connect it in the procedure described below. When installing the foot pedal switch, the foot pedal switch junction cable asm. (part number: 40114433) is also required. Refer to "11-6. Others" p. 114.

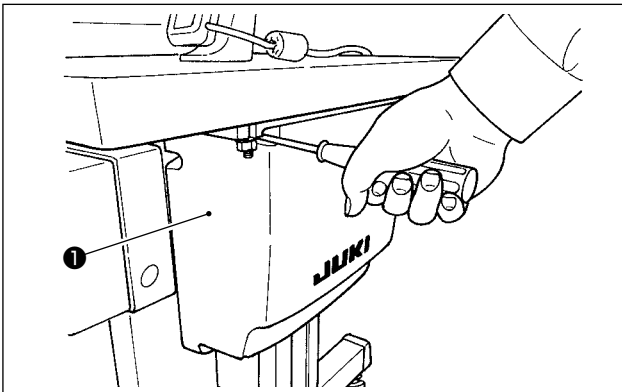

- 1) Loosen the four setscrews in the control box to remove cover ①.

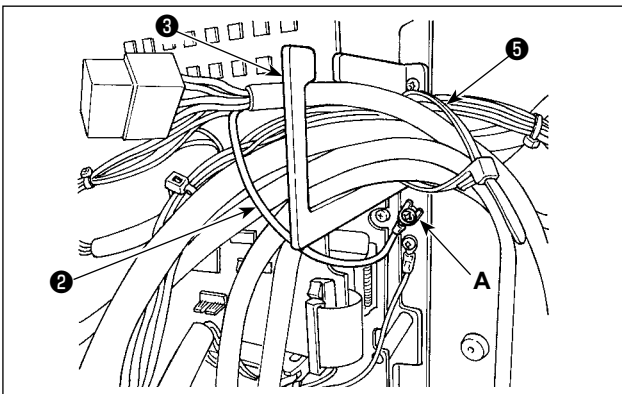

- 2) Fix earthing wire ② of the foot pedal switch at location A of the control box.

Caution
Pass the earthing wire through cord exit plate ③. If not, it can be caught under the cover when closing it.

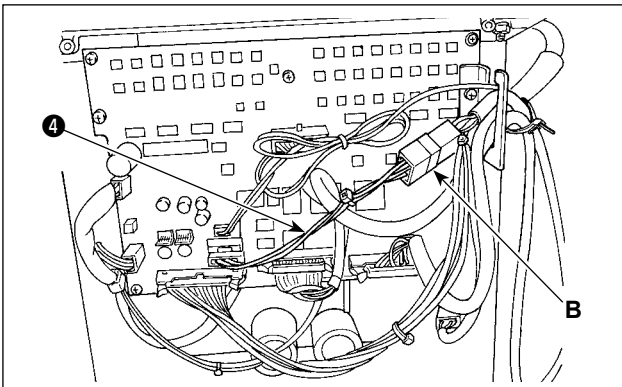

- 3) Connect foot pedal switch junction cable ④ to the foot pedal switch cable (B) and connect the opposite side of the junction cable to CN43 connector on the PWB (C).

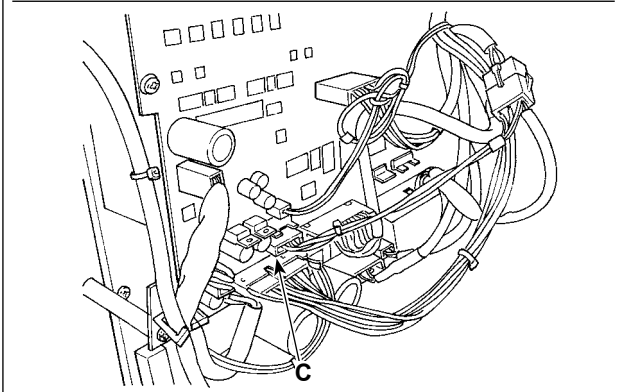

- 4) Fix the cable.
Loosen cable clip band ⑤. Fix the foot pedal switch cables (excluding earthing wire ②) by means of cable clip band ⑤ together with other related cables.

DANGER :



It is very important to carefully connect the cables to the correct connectors on the PWB. Wrong connection poses a great risk.



Even in the case the optional foot pedal switch is installed on the sewing machine, the hand switch is still enabled. Carefully operate the switches since the sewing machine is activated by operating either switch.

3-13. Connecting the air supply

(1) Connecting the regulator and the manifold

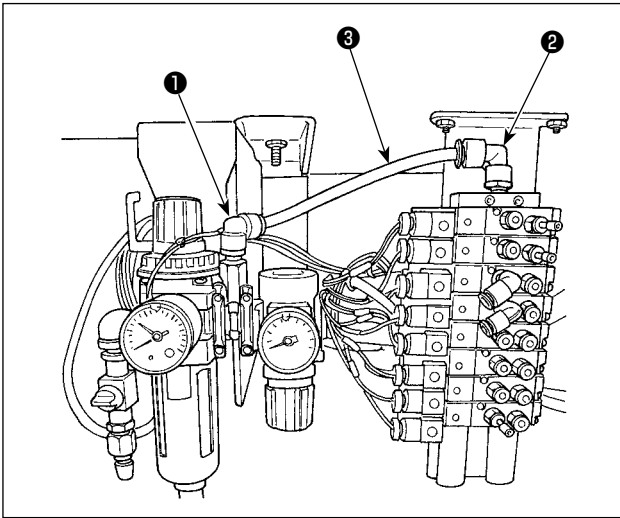

- 1) Connect joint ① of the regulator and joint ② of the manifold by means of the air tube $\varnothing 10$ ③.

[For the needle thread clamp]

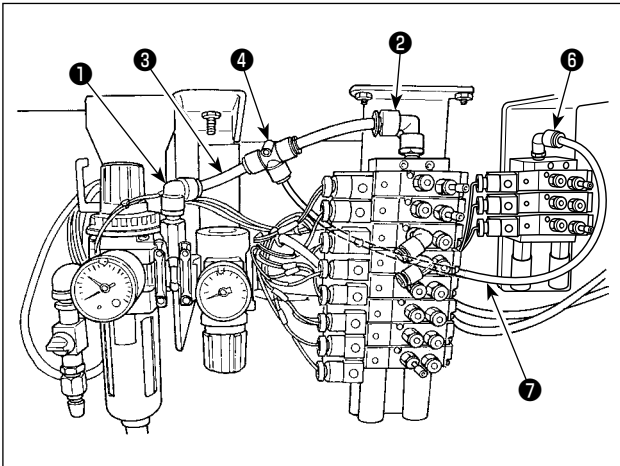

- 1)-1. Connect air tube $\varnothing 10$ ③ and joint ② of the manifold by means of T-joint ④ which has a short air tube.
- 1)-2. Connect T-joint ④ and joint ⑥ of the manifold for the needle thread clamp by means of air tube $\varnothing 10$ ⑦.

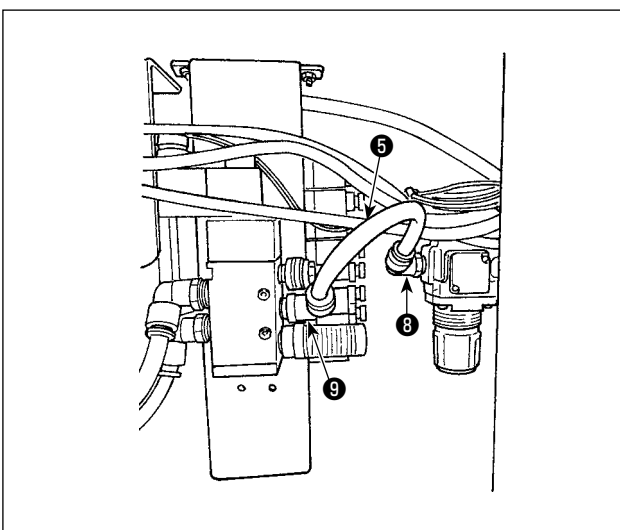

- 2) Connect joint ⑧ of the cloth trimming regulator and joint ⑨ of the cloth trimming solenoid valve by means of the air tube $\varnothing 10$ ⑤.

(2) Connecting the air tubes

Connect the respective air tubes coming from the sewing machine head to the respective solenoid valves matching their numbers correspondingly.

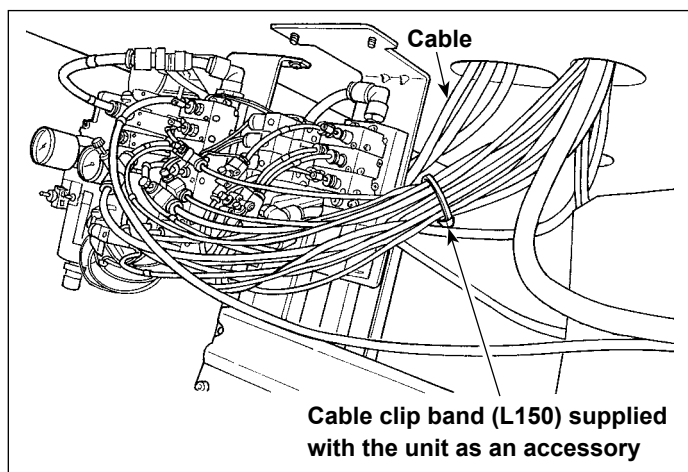
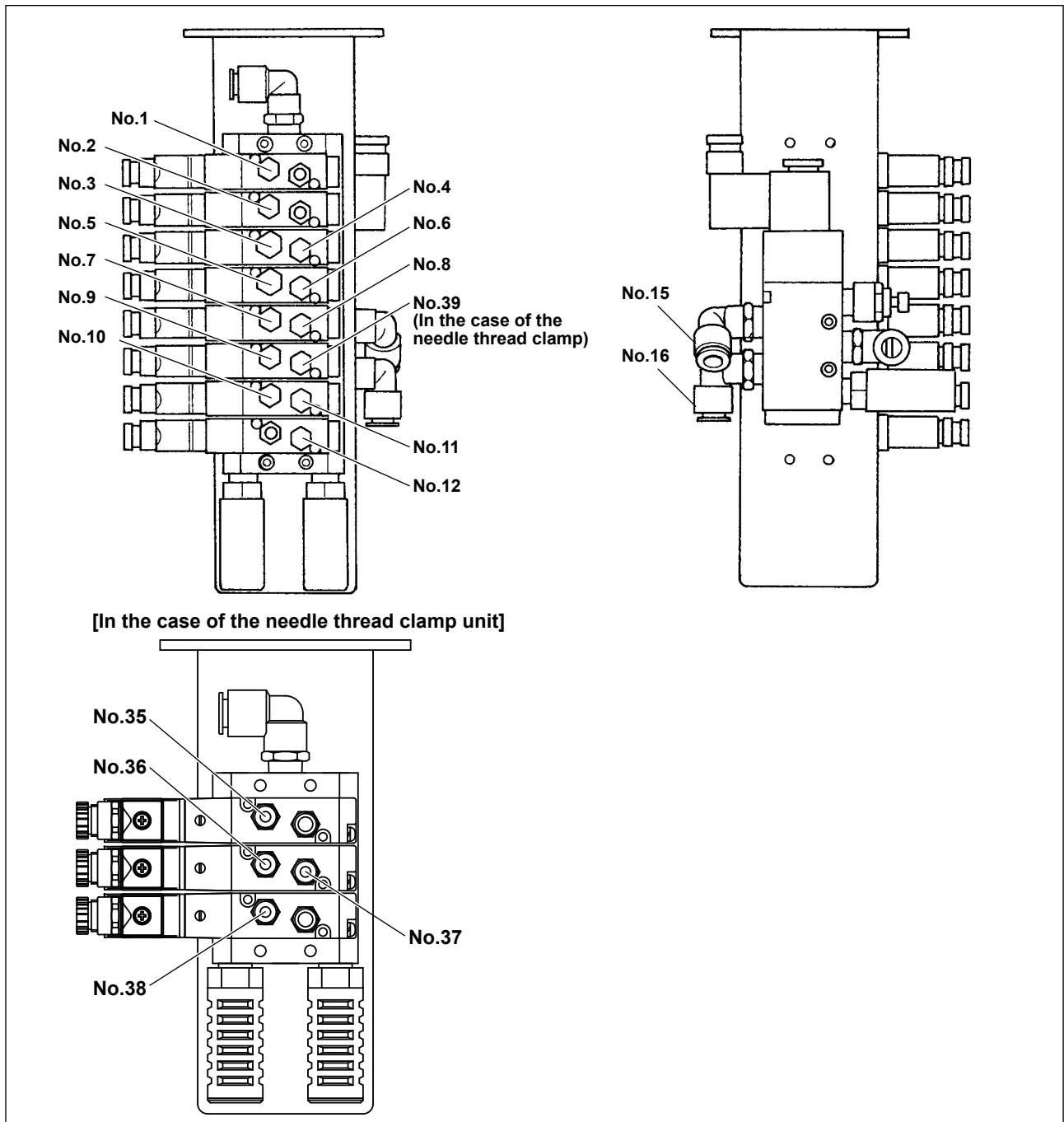

After the connection of the respective air tubes, neatly bundle the cables etc. coming from the sewing machine with the cable clip band supplied with the unit as an accessory.

3-14. Installing the air hose

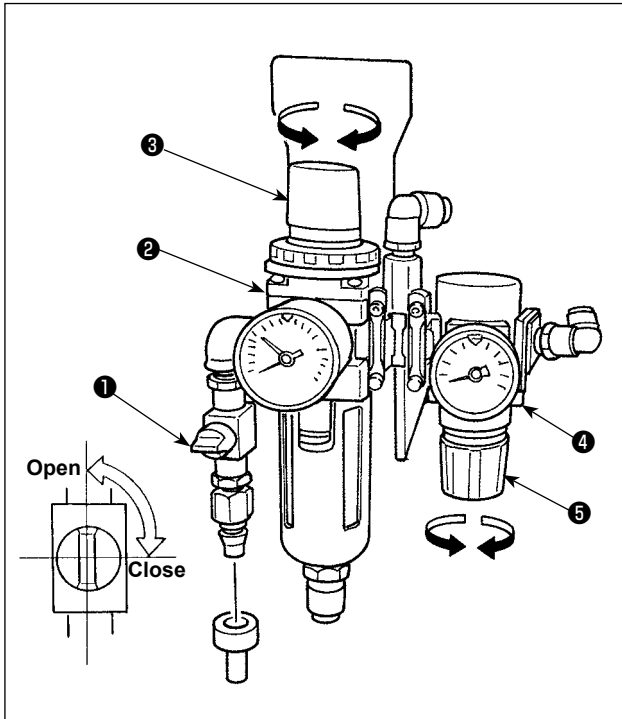

■ Connecting the air hose

Connect the air hose to the regulator using the hose band and quick-coupling socket joint supplied with the unit.

■ Adjusting the air pressure

Open air cock ①.

[Main regulator]

Pull up and turn air pressure regulating knob ③ of main regulator ② to adjust the pneumatic pressure to 0.5 MPa. Then, push down the knob to fix it.

[Regulator for cloth trimming knife pressure]

Pull down air pressure regulating knob ⑤ of regulator ④ for the cloth trimming knife pressure and turn it to adjust the air pressure to 0.35 MPa. Then, push up the knob to fix it.

(The air pressure of the cloth trimming knife can be adjusted in the range of 0.2 to 0.4 MPa by means of regulator ④.)

Regulator ④ for the cloth trimming knife has been factory-adjusted to 0.35 MPa. Do not increase the air pressure unless it is really necessary. Increased air pressure can cause a decrease in sharpness of the knife and/or knife breakage.



After the completion of the respective air pressures adjustment, close air cock ① to remove air. Then, re-open the air cock to adjust the respective air pressures.

* The air is removed by closing air cock ①.

3-15. Cautions for the compressed air supply (source of supply air) facility

As large as 90 % of failures in pneumatic equipment (air cylinders, air solenoid valves) are caused by "contaminated air."

Compressed air contains lots of impurities such as moisture, dust, deteriorated oil and carbon particles. If such "contaminated air" is used without taking any measures, it can be a cause of troubles, inviting reduction in productivity due to mechanical failures and reduced availability.

Be sure to install the standard air supply facility shown below whenever the machine provided with pneumatic equipment is used.

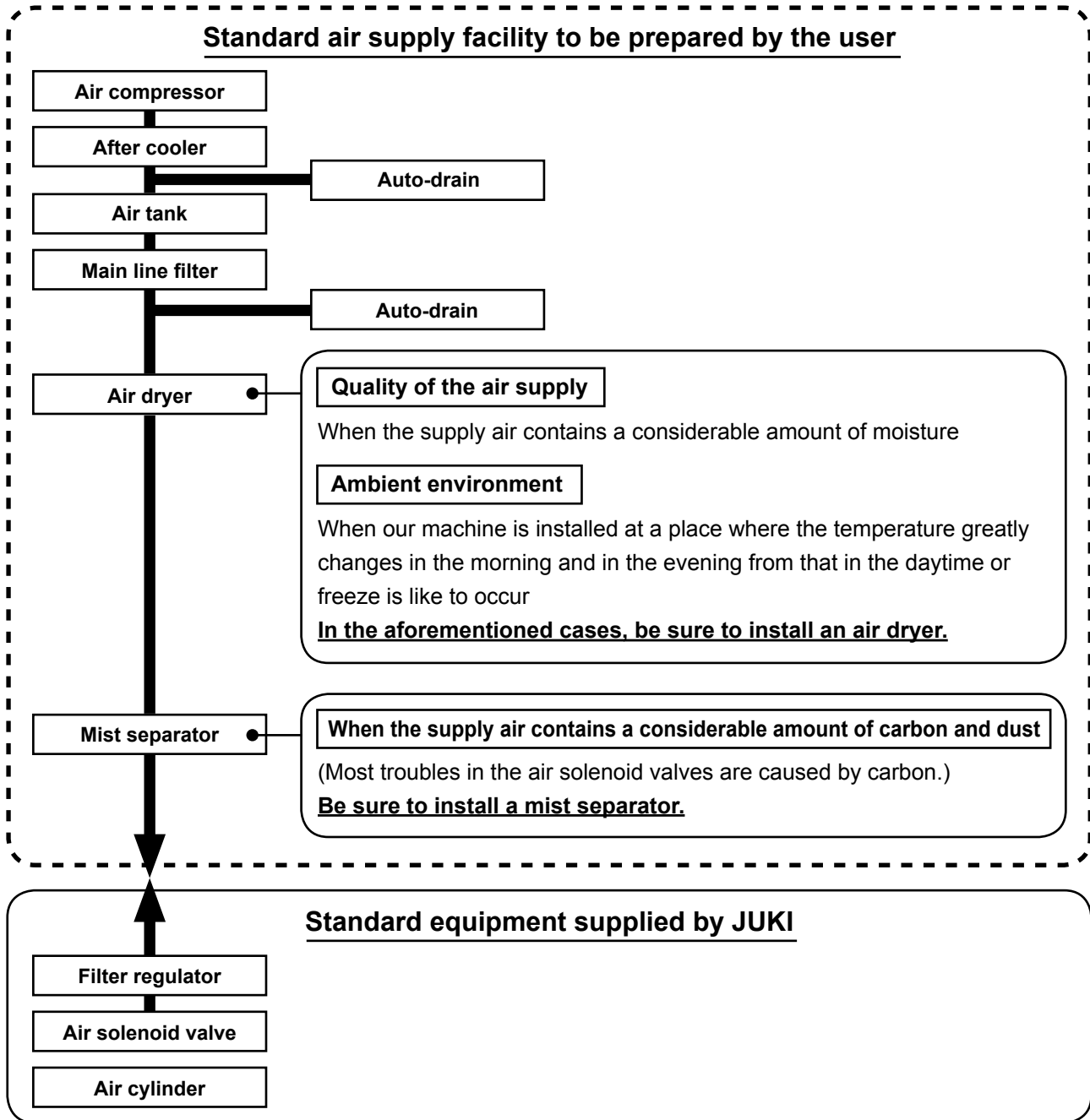

Cautions for main piping

- Be sure to slope main piping by a falling gradient of 1 cm per 1 m in the direction of air flow.
- If the main piping is branched off, the outlet port of the compressed air should be provided at the top part of the piping using a tee in order to prevent drain settling inside the piping from flowing out.
- Auto drains should be provided at all lower points or dead ends in order to prevent the drain from settling in those parts.



3-16. Installing the thread stand

- 1) Assemble the thread stand asm. and install it in the hole in the rear left part of the table.
- 2) Tighten locknut ❶ so that the thread stand is fixed.

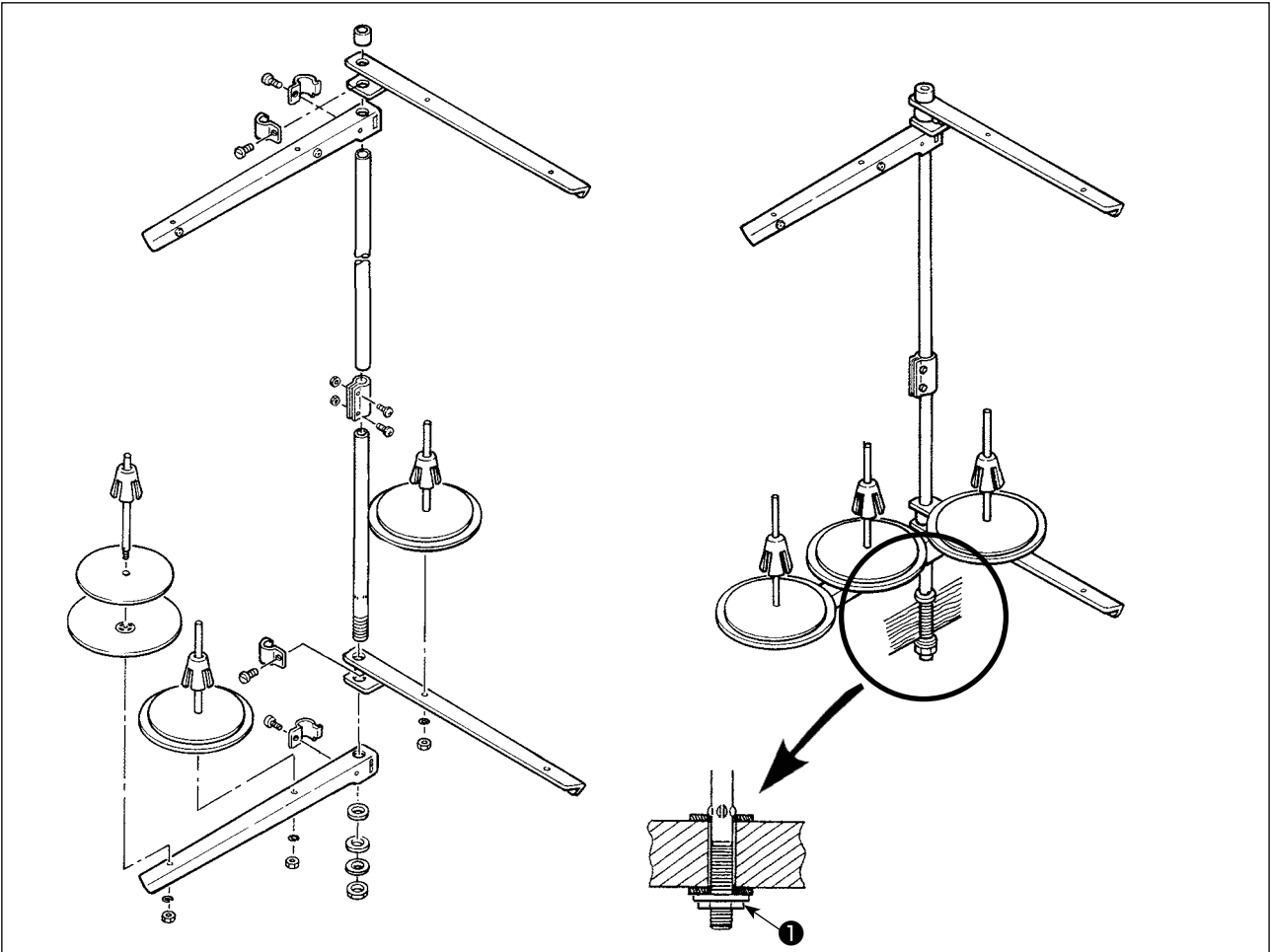

3-17. Installing the thread guides

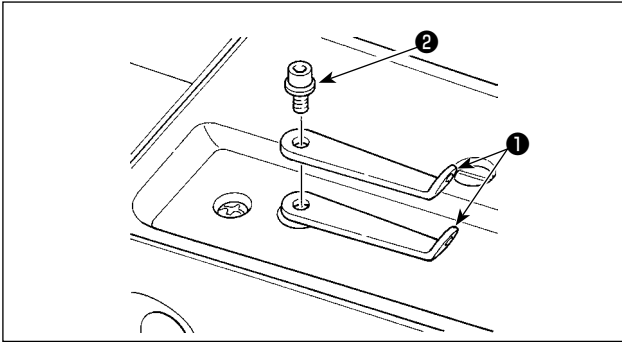

- 1) Remove two thread guide plates **1** and setscrew **2**.

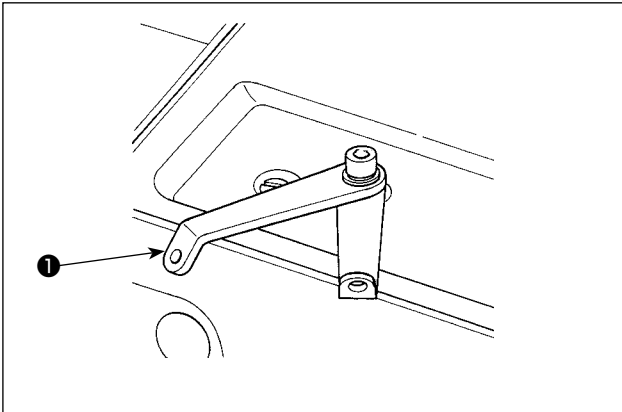

- 2) Reverse one of thread guide plates **1**. Install the thread guides so that they turn by approximately 40° to allow the thread to pass smoothly.

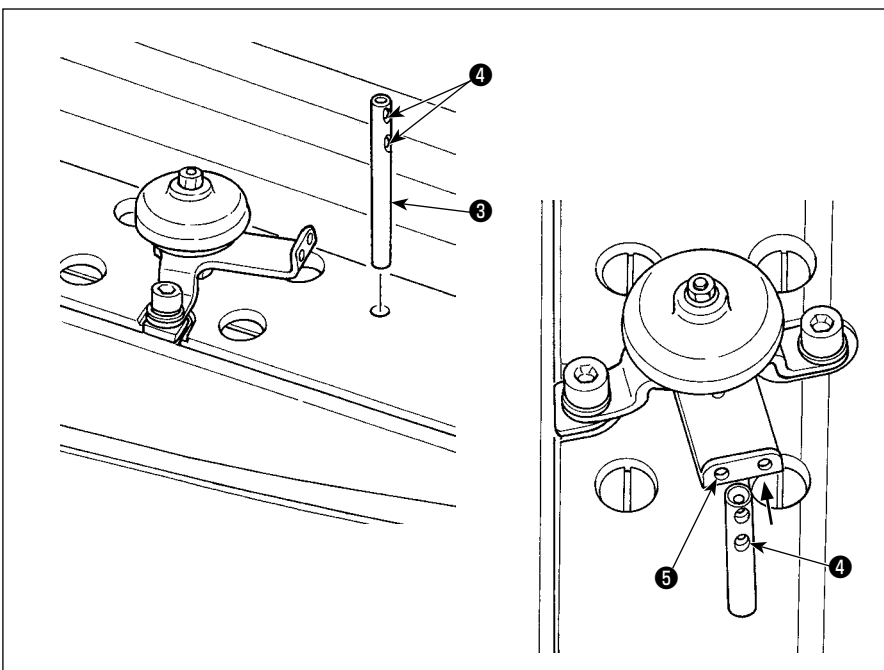
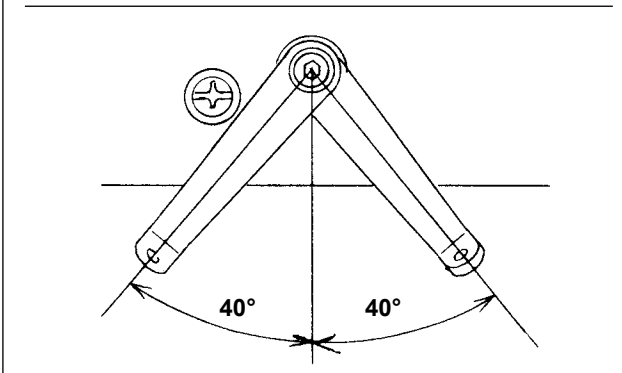

- 3) Install thread guide bar **3**. At this time, install thread guide bar **3** so that hole **4** in thread guide bar **3** is oriented to hole **5** in the AT thread guide.

3-18. Installing the eye protection cover and the finger guard



DANGER :

The eye protection cover and the finger guard are used to protect eyes against flying broken needle. Be sure to use the sewing machine with them installed without exceptions.

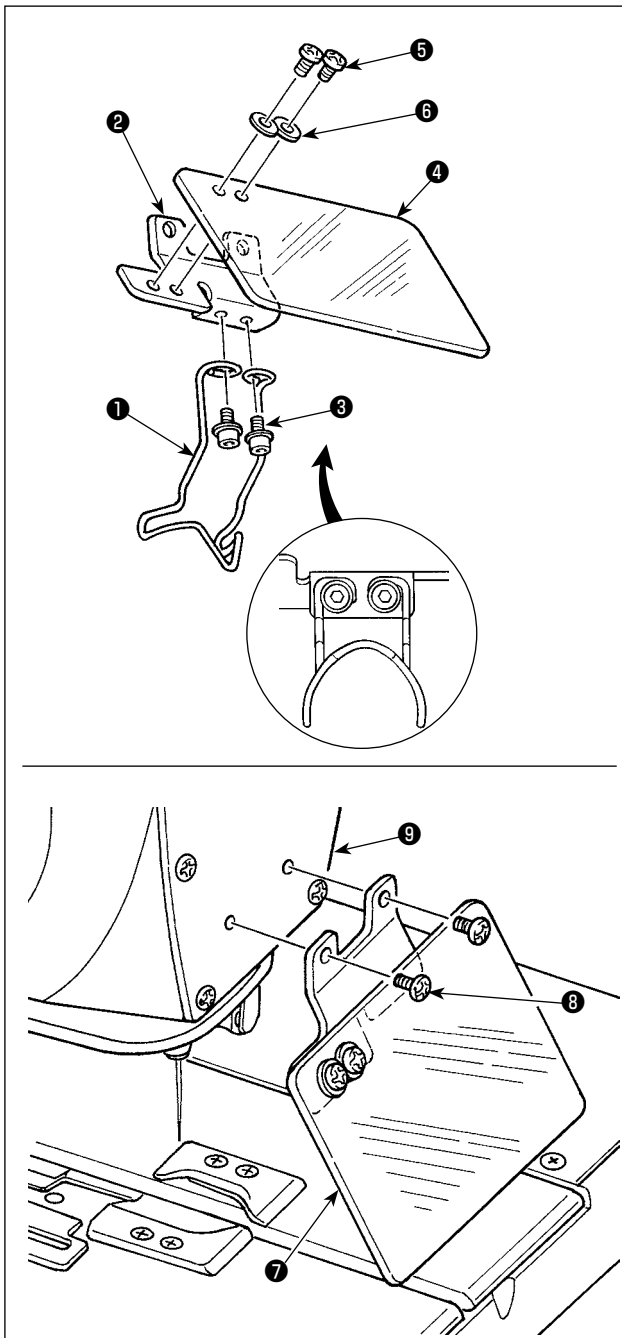

- 1) Assemble finger guard **1** to safety plate bracket **2** with two setscrews **3**.
Assemble finger guard **1** equally with respect to safety plate bracket **2**.
- 2) Assemble eye protection cover **4** to safety plate bracket **2** with two setscrews **5** and two washers **6**.
- 3) Install the assembled eye protection cover and finger guard asm. **7** on face plate **9** with screws **8**.

Setscrew **3** is an M4 hexagon socket head cap screw and has a length of 8 mm. Setscrew **5** is an M4 round head screw and has a length of 6 mm. Setscrew **8** is an M4 round head screw and has a length of 6 mm.



3-19. Installing the cloth chip bag

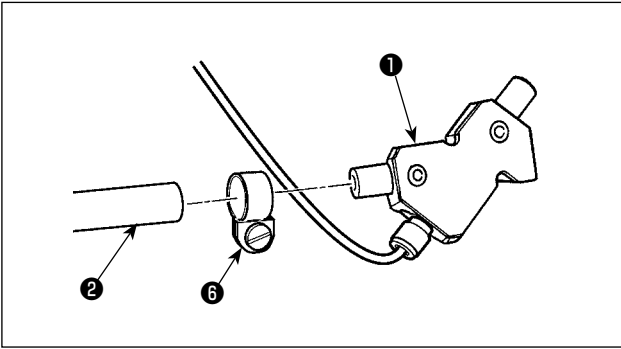

- 1) Connect cloth chip suction device ① and cloth chip tube ②. Fix them with hose band ⑥.

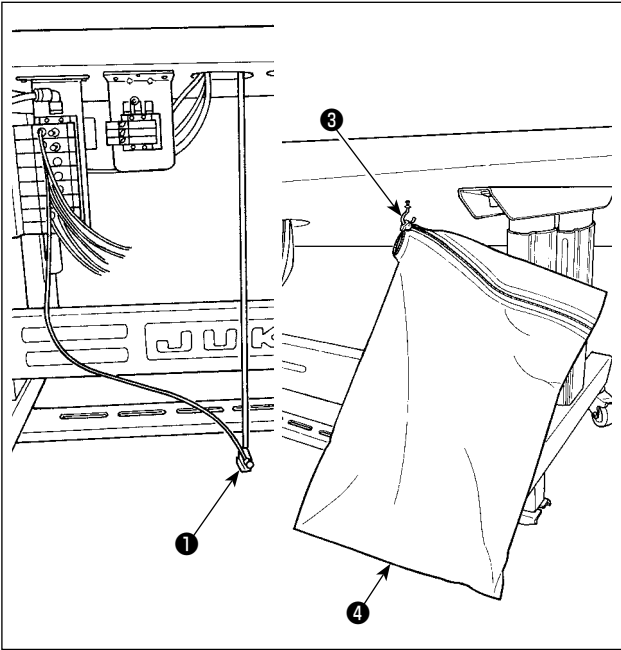

- 2) Install suspension hook ③ to an easy-to-access location on the underside of the table.
- 3) Suspend cloth chip bag ④ on suspension hook ③.

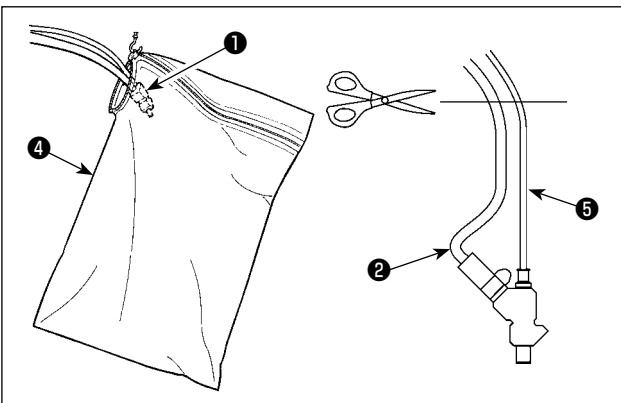

- 4) Open the zipper of cloth chip bag ④ to put cloth chip suction device ① in it.
- 5) Place cloth chip suction device ① in the top part of cloth chip bag ④ and close the zipper. Adjust the length of cloth chip tube ② by cutting it short at the point immediately below the table.

If cloth chip tube ② is excessively long, cloth chip tube ② can be clogged with cloth chips since cloth chips can interrupt the air flow from cloth chip suction device ①.

Be sure to empty the cloth chip bag before cloth chips in the bag reach the top of cloth chip suction device ①.



3-20. Installing/removing the presser unit



Carefully prevent contact between the cloth trimming knife and the work clamp plate when moving the feed base by hand or installing/removing the work clamp unit.

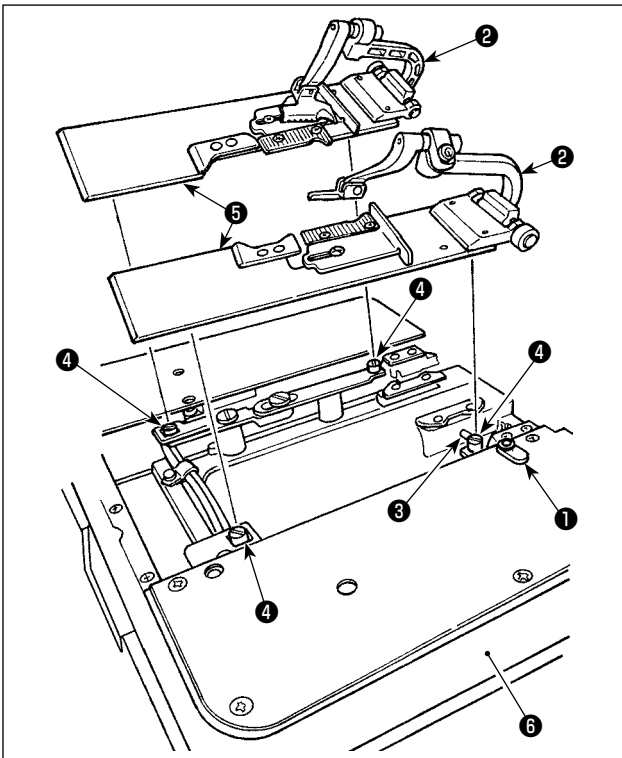

■ How to install

- 1) Install the presser unit so that presser lever **3** fits in the letter "U" of presser base **2**.
- 2) Adjust the hole of presser plate **5** to cloth open pin **4**.
- 3) Turn clamp holding plate **1** to hold presser plate **5**.

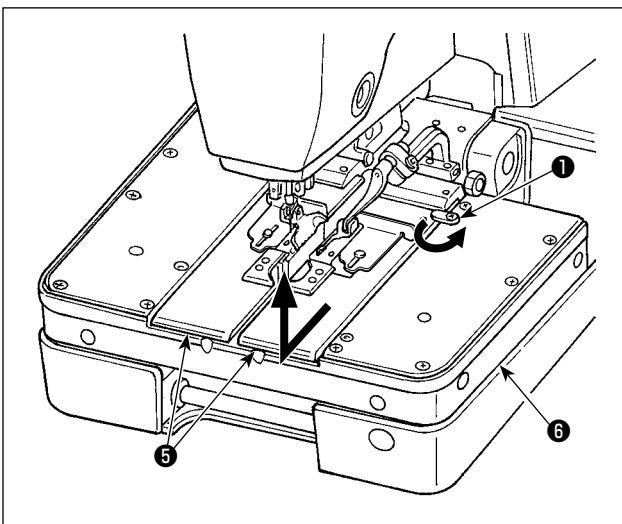

■ How to remove

- 1) Turn clamp holding plate **1** to remove from presser plate **5**.
- 2) Lifting presser plate **5**, remove it so as to draw it.



It is comparatively easy to install or remove the presser unit by moving feed base **6** to the cloth cutting position.

When moving feed base **6** by hand, follow the aforementioned caution.

4. PREPARATION BEFORE OPERATION

4-1. Lubrication of the machine and how to lubricate



WARNING :

Turn OFF the power before starting the work so as to prevent accidents caused by abrupt start of the sewing machine.

* Use JUKI New Defrix Oil No. 2 or JUKI MACHINE Oil No. 18 as the machine oil.

(1) Lubricating the arm oil tank

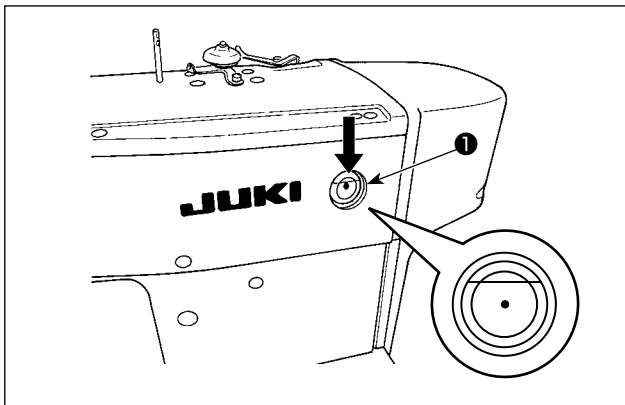

Lubricate arm tank ① to such an extent of approximately 80 %.

In addition, add oil in the case the oil level has decreased below the red marker dot during the daily use of the sewing machine.

(2) Lubricating the bed oil tank

[In the case of the table-fixed type machine head]

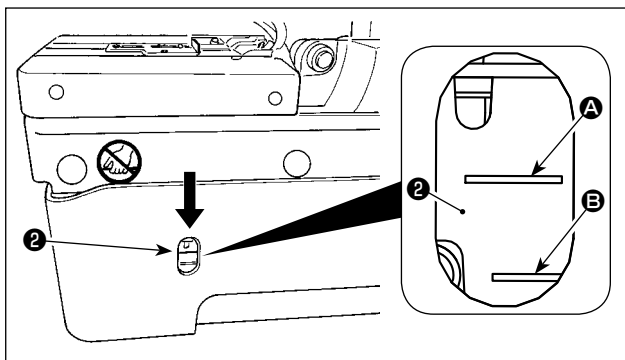

Lubricate bed oil tank ② up to the MAX. line ①.

In addition, when the oil surface falls below the MIN line ② during daily use, add an adequate quantity of oil.



If oil is added so that the oil level exceeds the MAX line ①, the oil will spill out of the oil hole when the machine head is tilted until it will go no further. Be careful when replenishing the oil tank with oil.

[In the case of the semi-sunken type machine head]

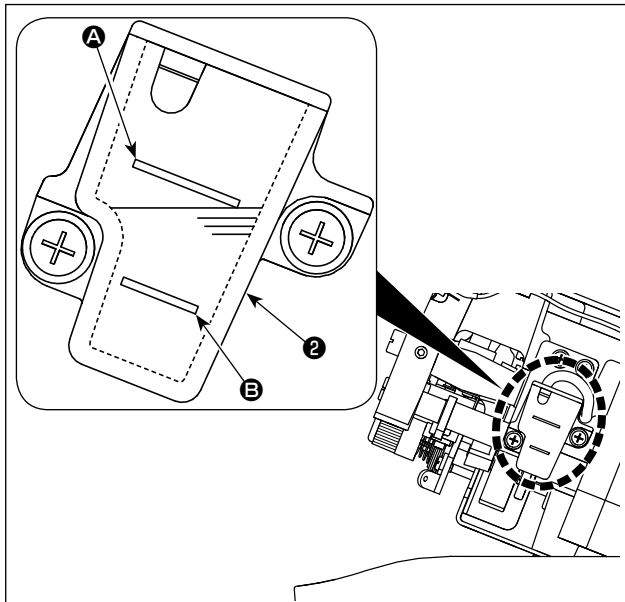

Raise the sewing machine to the 2nd step of the hinge. Add oil in bed oil tank ② until the oil surface reaches the underside of MAX line ①.

In addition, when the oil surface falls below the MIN line ② during daily use, add an adequate quantity of oil.



Be aware that oil will spill out from the oil hole when tilting the machine head if the added oil surface exceeds the underside of MAX line ①.

(3) Lubricating the looper and spreader components

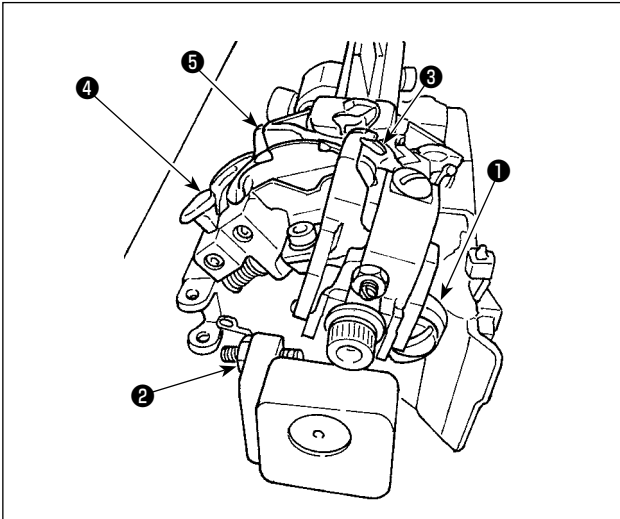

- 1) Remove the presser plates, right and left.
- 2) Apply two to three drops of oil to looper link ①, spreader link ②, spreader, right ③, spreader, left ④ and spreader actuating cam ⑤.



Be sure to lubricate the components once a day. If the frequency of lubrication is small, especially, worn-out of ③, ④ and ⑤ is caused and stitch skipping or needle breakage will occur.

(4) Lubricating the looper bracket oil tank

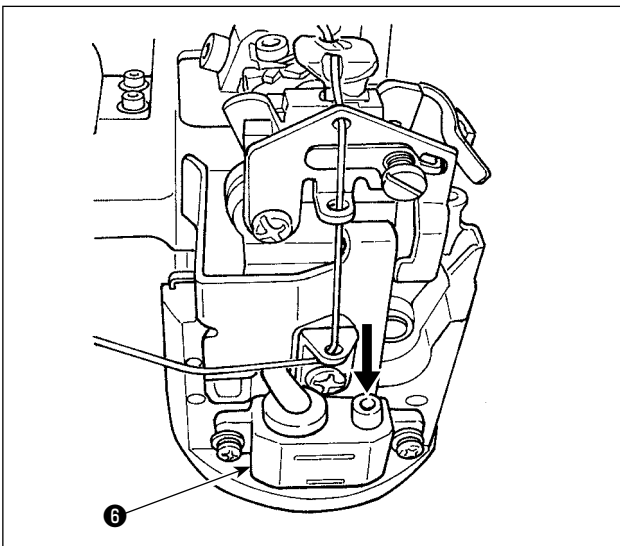

Put oil in looper bracket oil tank ⑥ until its MAX line is reached.

In addition, when the oil surface falls below the MIN line during daily use, add an adequate quantity of oil.



Put oil in the looper bracket oil tank using the oiler (smaller one) supplied with the unit while taking care not to spill oil around the tank.

Oil spilled around tank can fly toward the operator by the looper bracket operation when the machine is running. Be sure to wipe up the spilled oil to prevent the above.

(5) Lubricating the needle bar and the gear section



Lubricate the components at the time of delivery or after an extended period of disuse.

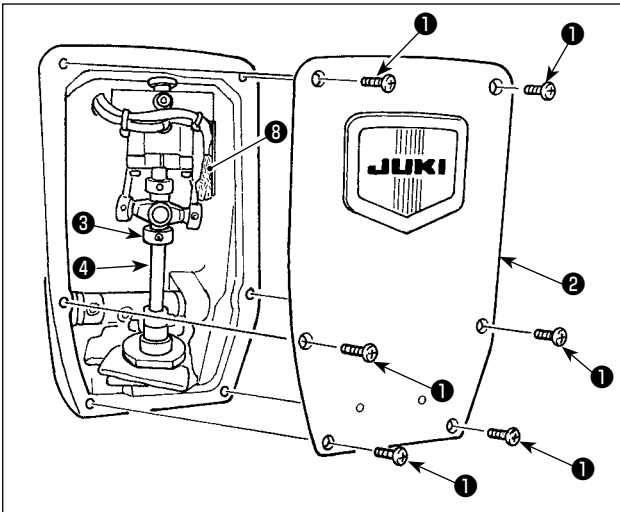

- 1) Loosen setscrews ① and remove face plate ②.
- 2) Apply one or two drops of oil to needle bar bushing ③, needle bar ④ and felt ⑧.

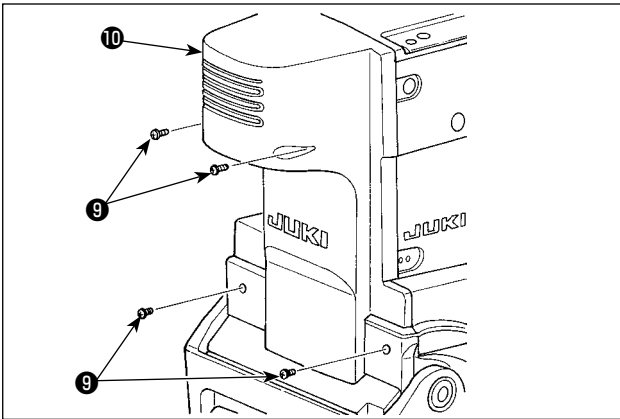

- 3) Loosen setscrew ⑨. Remove rear cover ⑩.

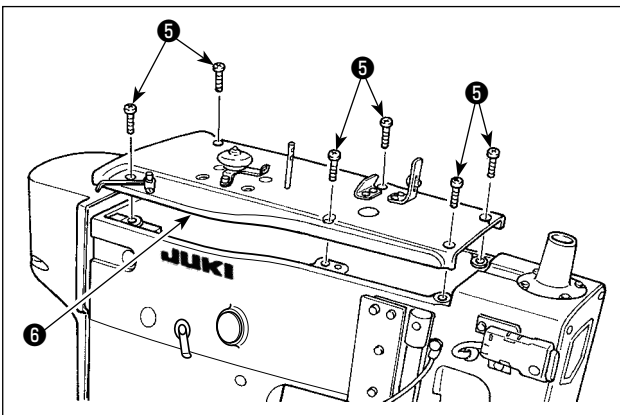

- 4) Loosen setscrew ⑤ and remove the upper face cover ⑥.



Remove the cover with care since the air tube is connected with the cord.

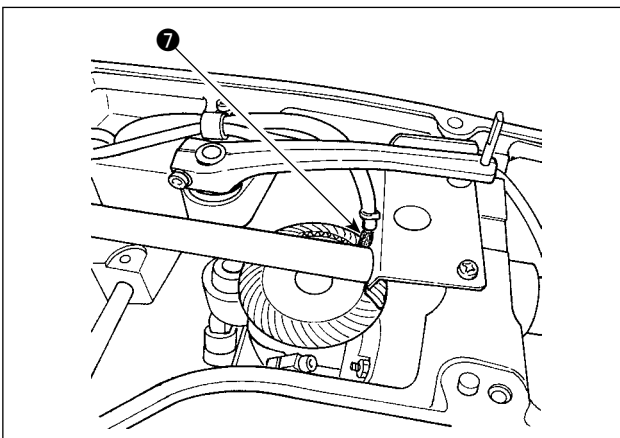

- 5) Apply oil to gear lubricating felt ⑦ in the sewing machine arm.
- 6) After lubrication, install face plate ② and upper face cover ⑥.



Be careful not to allow the cords to be caught in the machine.

4-2. Attaching the needle



WARNING :

Turn OFF the power before starting the work so as to prevent accidents caused by abrupt start of the sewing machine.

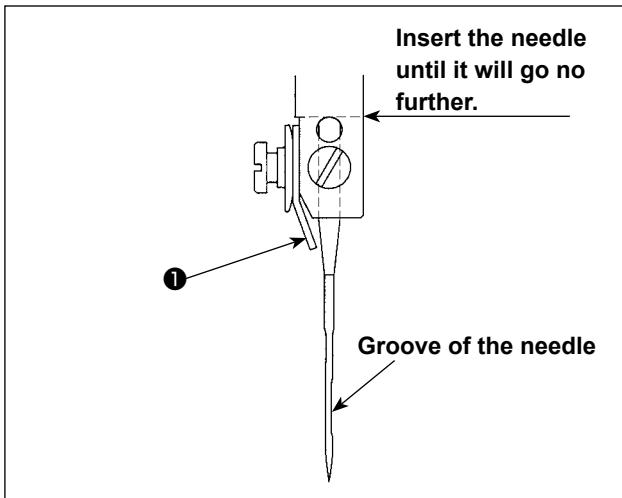

The correct direction of the needle is that needle thread guide ① faces the opposite side of groove of the needle.



1. Use the most suitable size of needle in accordance with the kind and thickness of thread and kind of material to be used.
2. When changing the size of needle, be sure to adjust the clearance between the needle and the looper. (Refer to "10-5. Clearance between the needle and the looper" p. 100.)

4-3. Threading the machine head



WARNING :
Turn OFF the power before starting the work so as to prevent accidents caused by abrupt start of the sewing machine.

(1) Threading the upper thread (needle thread)

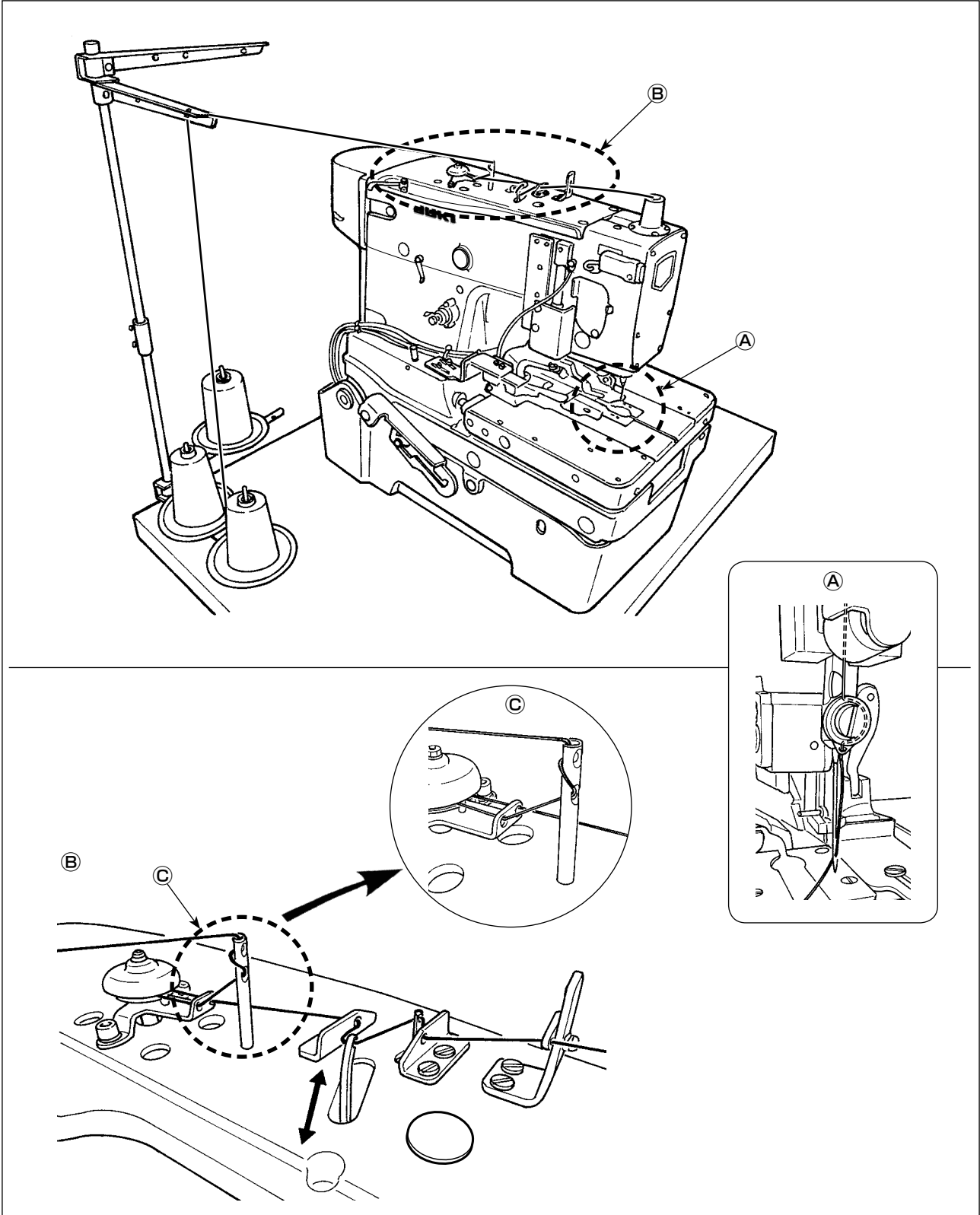

(2) Threading the lower thread (looper thread)

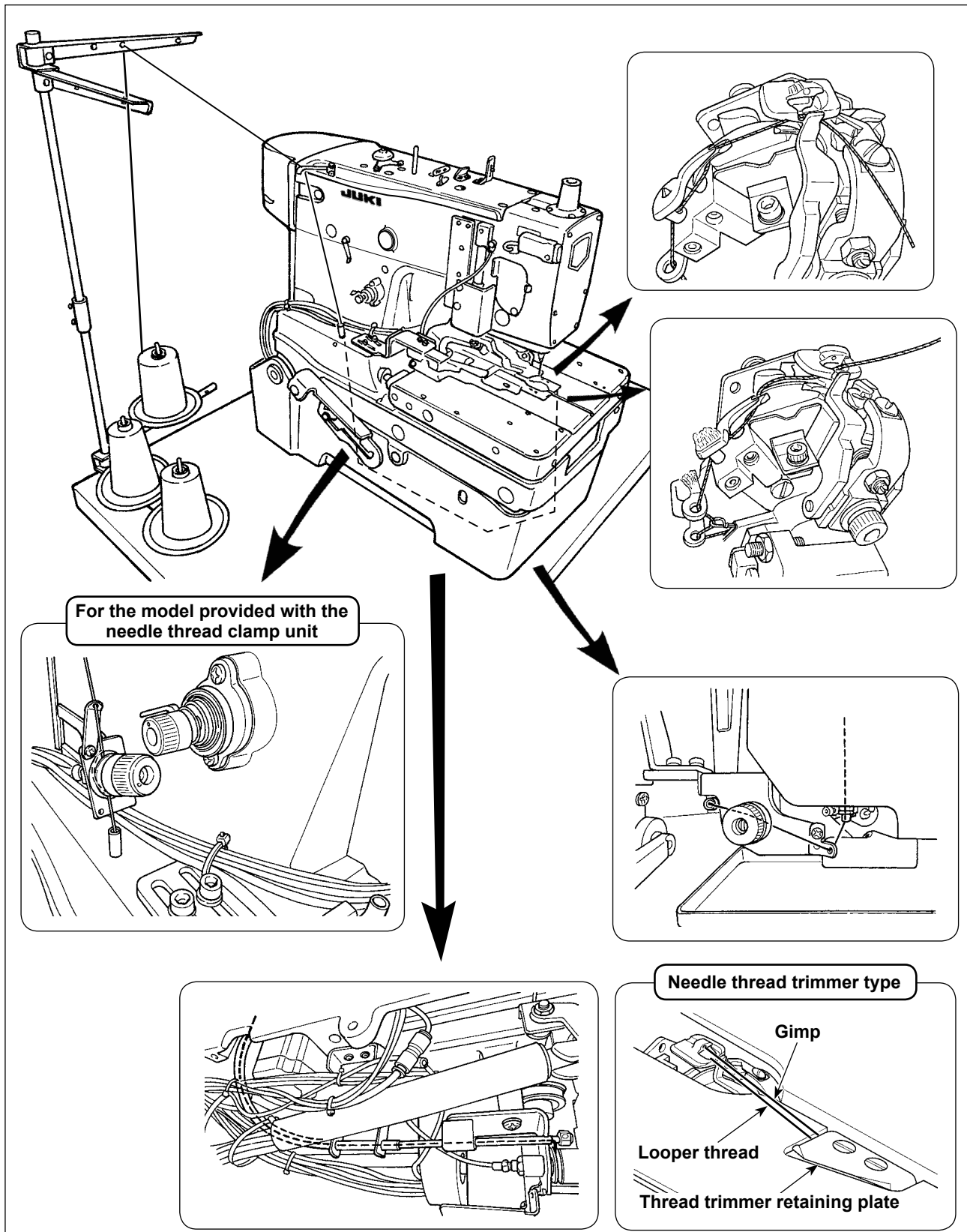

1. When passing the looper thread, turn looper bracket by 180 degrees of an angle in advance.
 2. In the case of the overall thread trimmer type machine, pass the looper thread through the needle hole in the throat plate and allow the looper thread clamp to clamp it. Then, start sewing. In the case of the needle thread trimmer type machine, allow the thread trimmer retaining plate to clamp the looper thread and gimp. Then, start sewing.
- If thread waste is clamped by the looper thread clamp or the thread trimmer retaining plate, remove it. If sewing is carried out when the thread waste remains clamped by either of them, the looper thread cannot be clamped properly, resulting in stitch skipping at the beginning of sewing.



(3) Threading the machine with gimp

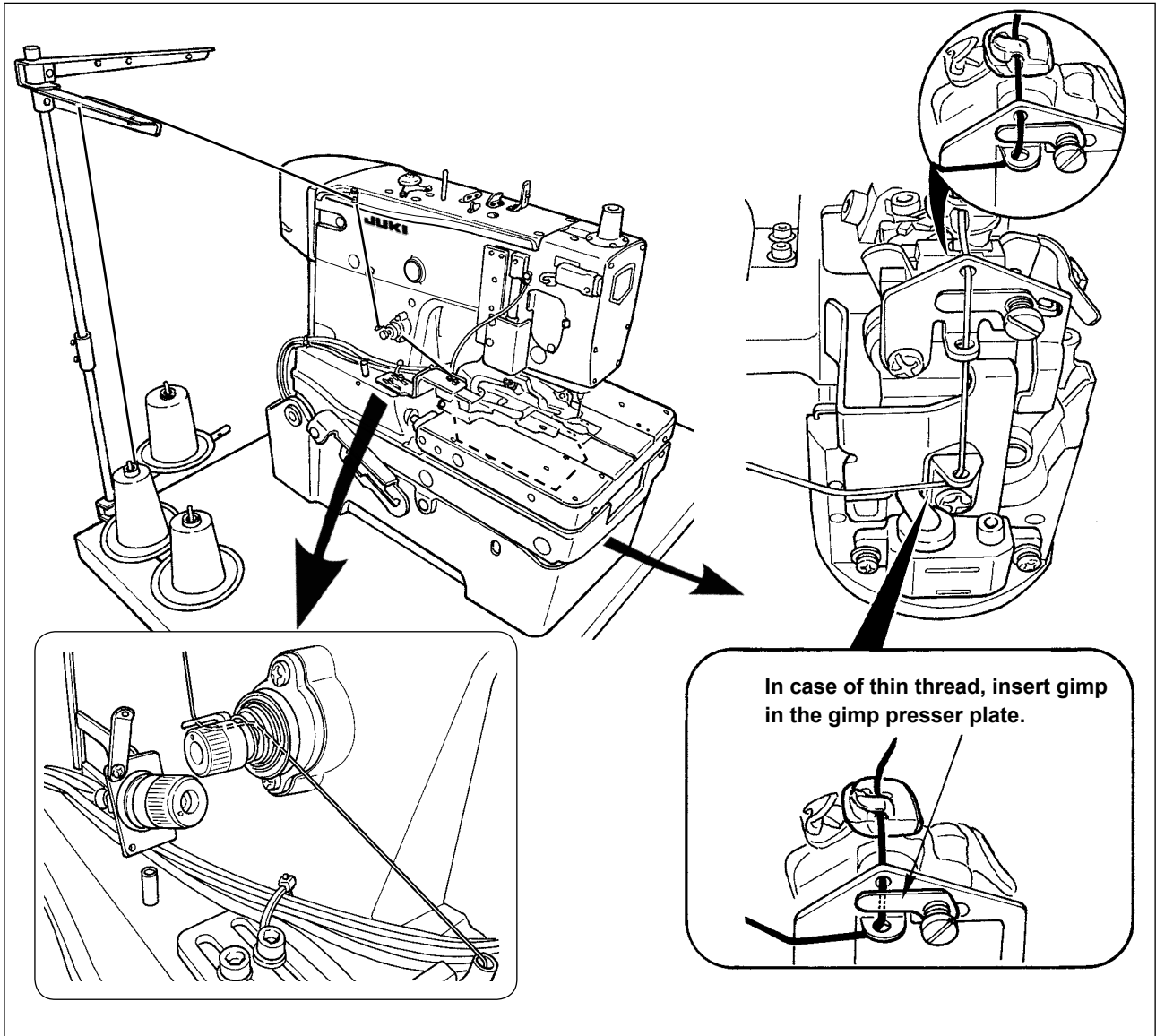

4-4. How to set the cloth on the sewing machine

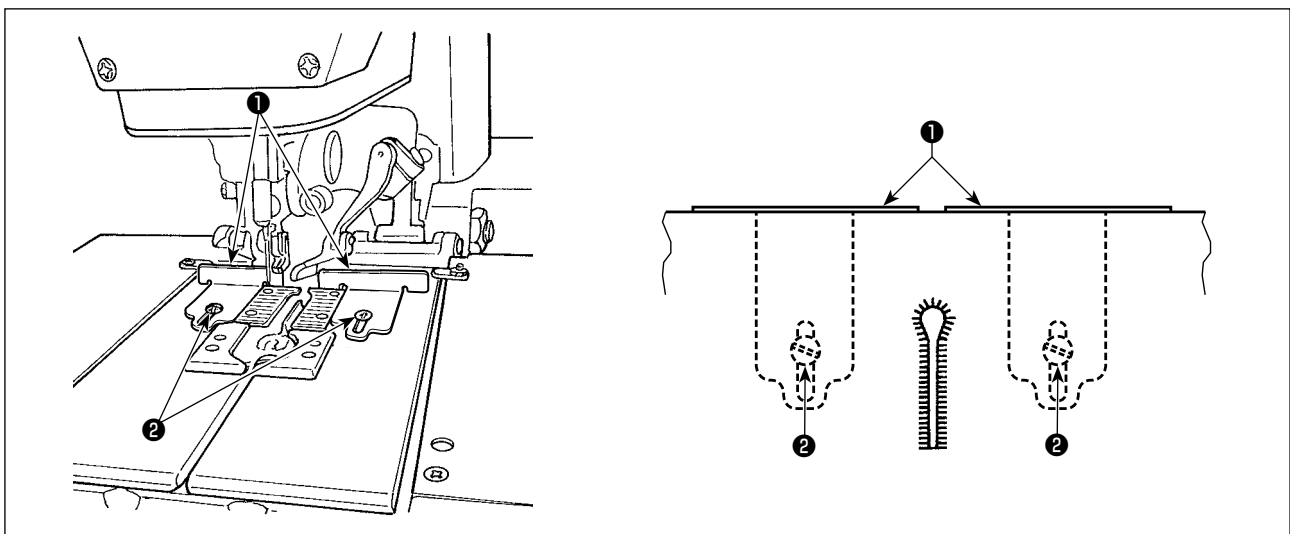

- 1) Enter the sewing material until it comes in contact with cloth patches ❶, right and left.
- 2) Loosen setscrews ❷, right and left and adjust the sewing position by moving the cloth patches to and fro.



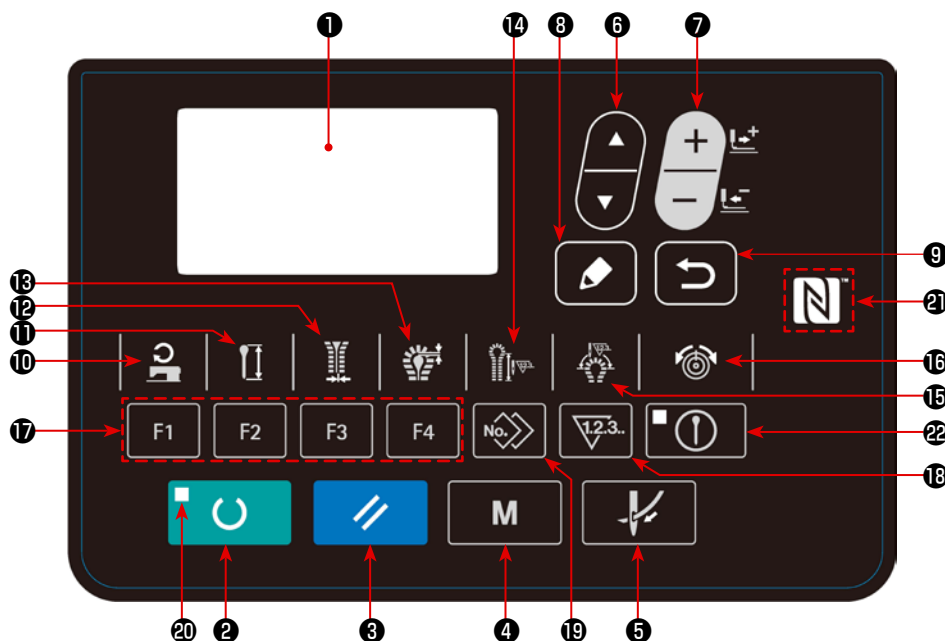

5. STRUCTURE OF THE OPERATION SWITCH

5-1. Structure of the operation panel



[Table of functions of the operation panel]

No.	NAME	FUNCTION	No.	NAME	FUNCTION
①	LCD display	Various data such as pattern No., shape, etc. are displayed.	⑩	SEWING SPEED key	This key is used to display the parameter edit items related to the sewing speed.
②	READY key	Press this key when starting sewing. Every time this key is pressed, change-over of sewing ready set state and data set state can be performed.	⑪	CUT LENGTH key	S002→Cut length input screen is displayed.
③	RESET key	Press this key when releasing error, travelling the feed mechanism to its initial position, counter resetting, etc.	⑫	CUT SPACE key	S006→The screen for inputting the parallel-section cut space is displayed.
④	MODE key	This key is used for displaying the mode screen.	⑬	EYELET SPACE key	S006→The screen for inputting the eyelet-section cut space is displayed.
⑤	THREADING key	When this key is pressed, the sewing machine enters the threading mode. (Note 1)	⑭	NUMBER OF PARALLEL-SECTION STITCHES key	S004→The screen for inputting the number of parallel-section stitches is displayed.
⑥	ITEM SELECT key	This key is used to select the data No. and other kinds of data.	⑮	NUMBER OF EYELET-SECTION STITCHES key	S005→The screen for inputting the number of eyelet-section stitches is displayed.
⑦	DATA CHANGE key	This key is used to change the pattern No. and other kinds of data. This key is used to move the feed forward on a stitch-by-stitch basis.	⑯	THREAD TENSION key	Thread tension display is selected.
⑧	EDIT key	This key is used to display the edit screen, to select the item or to display the detail screen.			
⑨	RETURN key	This key is used to return the screen to the previous one.			

No.	NAME	FUNCTION	No.	NAME	FUNCTION
17	PARAMETER REGISTRATION key 	This is the shortcut key to which a parameter can be assigned. Shortcut to the setting display for a desired pattern, sewing parameter and memory switch can be done with this switch. For the setting procedure, Refer to "9-9. Using parameter register key" p. 89.	19	COPY key 	Press this key when copying pattern. Refer to "9-6. How to copy / delete the sewing pattern" p. 87.
18	COUNTER key 	This key selects counter display. Refer to "6-6. How to use the counter" p. 48.	20	SET READY LED	It lights up under the sewing mode.
			21	NFC mark 	Bring the tablet or smartphone close to the NFC mark when carrying out communication.
			22	KNIFE ON/OFF key 	This key is used for changing over the status of cloth trimmer between "operation / no operation". (Note 2) In the case the LED is ON: The cloth trimmer operates In the case the LED is OFF: The cloth trimmer does not operate.

Note 1 : The key is disabled immediately after the power-on. It is enabled after the completion of feed-base origin retrieval by pressing the ready key once.

Note 2 : In the case the data "S003 Cut before knife / Cut after knife" of the pattern data is set to "No knife", the trimmer ON/OFF key is disabled.

5-2. Temporary stop switch

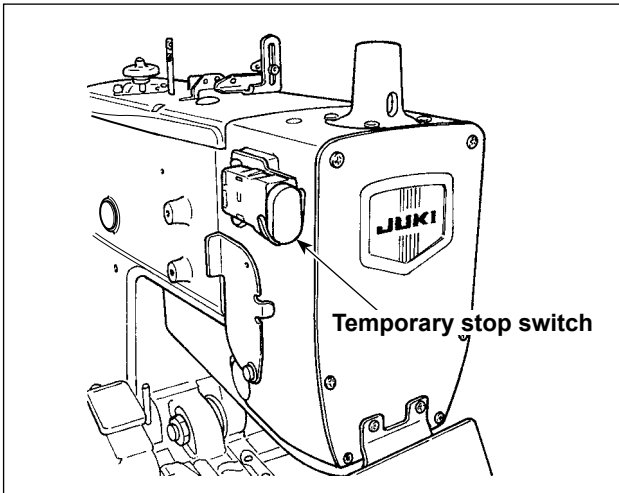

This switch stops the operation of the sewing machine.

5-3. Hand switch

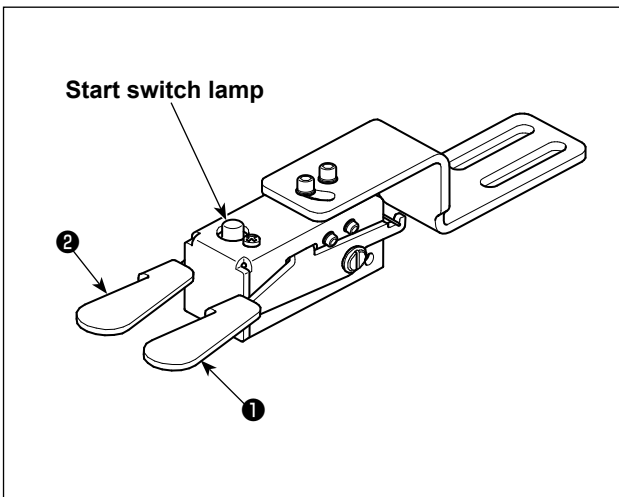

[**Presser switch (right) ①**]

This switch performs up/down of the presser.

[**Start switch (left) ②**]

This switch performs the start of sewing.



When the start switch is effective, the start switch lamp flashes on and off.



Before starting the sewing machine, close the front cover.

5-4. Foot switch (optional)

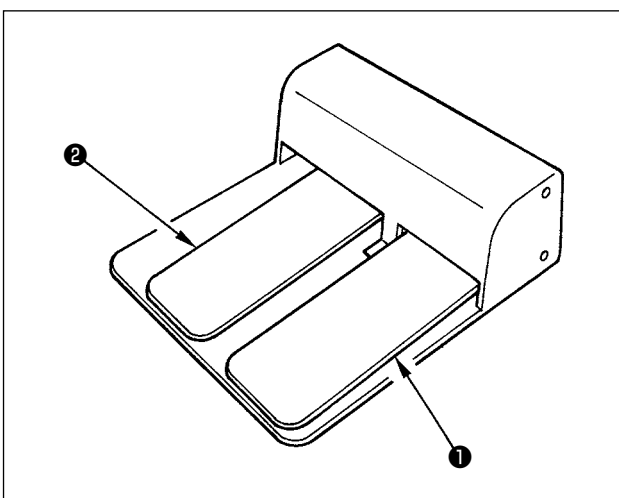

[**Presser switch ①**]

This switch performs up/down of the presser.

[**Start switch ②**]

This switch performs the start of sewing.



Before starting the sewing machine, close the front cover.

6. HOW TO USE THE OPERATION PANEL

In the case the sewing machine stops with its needle-bar rested in any position other than the upper end when the READY key  ② is pressed, Error (E030) will occur to stop the sewing machine.

In this case, turn the hand pulley to move the needle bar to its upper stop position. Error (E030) will disappear when the upper stop position is reached. In this state, press the READY key  ② again to light up sewing LED ⑳.





In addition, the needle bar will automatically return to the upper stop position when you press the READY key  ② even in the case the needle bar is not brought to its upper stop position as long as the needle bar rests at any position between the upper stop position and a point short of the lower dead point.

6-1. Basic operation of the sewing machine

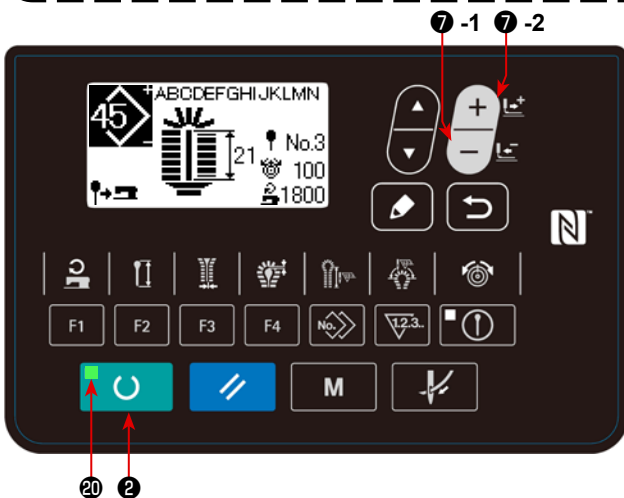

Standard patterns of pattern numbers 88 to 99 have been factory-set at the time of shipment. Refer to "15. STANDARD PATTERN LIST" p. 123 for pattern shapes.



1) Press $-$ /BACKWARD key  ⑦-1 or $+$ /FORWARD key  ⑦-2, to select the target pattern number you want to sew.

2) Press Ready key  ② to light up Sewing LED ⑳ to enable sewing. At this time, the presser foot comes down and the feed bar and needle retrieve the respective origins.



The presser and the feed base operate. Be careful that hands or fingers are not being caught in them.

3) Place the sewing material under the presser foot. Press the Presser foot switch to lower the presser foot. Press the Start switch to start sewing.





Before starting the sewing machine, close the front cover.



6-2. Setting the thread tension

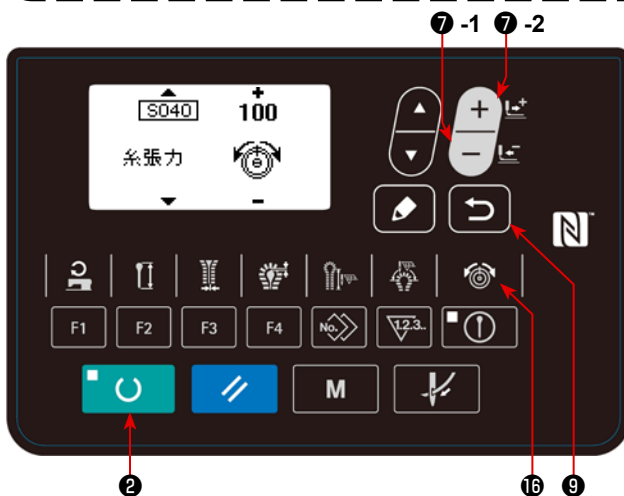

The actual thread tension varies in accordance with the kind or thickness of thread used even when the set value is the same. Adjust the thread tension value to the thread used. If the thread tension set value is high, stitch skipping may be caused.



1) Press THREAD TENSION key  ⑩ to display the thread tension value.

2) Set the value of the thread tension by pressing $-$ /BACKWARD key  ⑦-1 or $+$ /FORWARD key  ⑦-2.

3) The set value is stored in memory when you press Ready key  ② or press the Start switch to start sewing.

4) Press RETURN key  ⑨ to return the current display to the normal display.



Thread tension to be applied to the respective sections of the sewing pattern can be changed separately. Refer to "9-1. Operating procedure of thread tension compensation of each section" p. 83.



If the pattern number is changed or the power is turned off without taking the procedure 3), the set value will not be stored in memory.

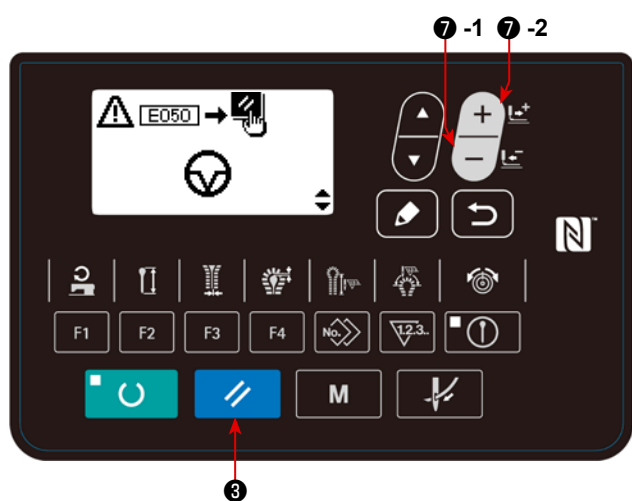
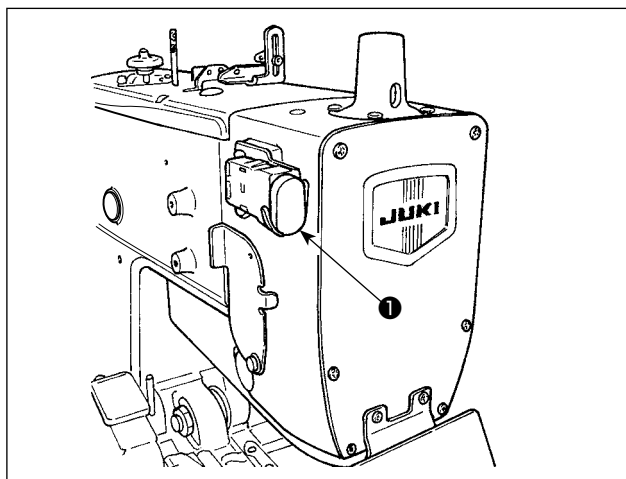

6-3. Temporarily stopping the sewing machine



■ How to stop the sewing machine



- 1) Press temporary stop switch ①.
- 2) The sewing machine stops and "E050" is displayed.

■ How to re-start

- 1) While "E050" is shown on the screen, press RESET key  ③ to release the error and to restore the screen to the display before the occurrence of the error.
- 2) Re-start the sewing machine using the start switch, or press -/BACKWARD key  ⑦-1 or +/FORWARD key  ⑦-2 and the feed mechanism travels forward/backward stitch by stitch.

Further, press RESET key  ③ to return the sewing machine to the sewing start position.

1. Operation of -/BACKWARD key

⑦-1 or +/FORWARD key  ⑦-2 key or RESET key  ③ cannot perform thread trimming.

2. When temporarily stopping the sewing machine during sewing and returning the sewing machine to the start position

with RESET key  ③, draw out needle thread, cut the thread with scissors or the like and perform the work. The work can be performed without applying a forced load to needle or sewing product.



Before starting the sewing machine, close the front cover.

6-4. Performing re-sewing

Sewing can be performed without cloth-opening operation of the presser foot.

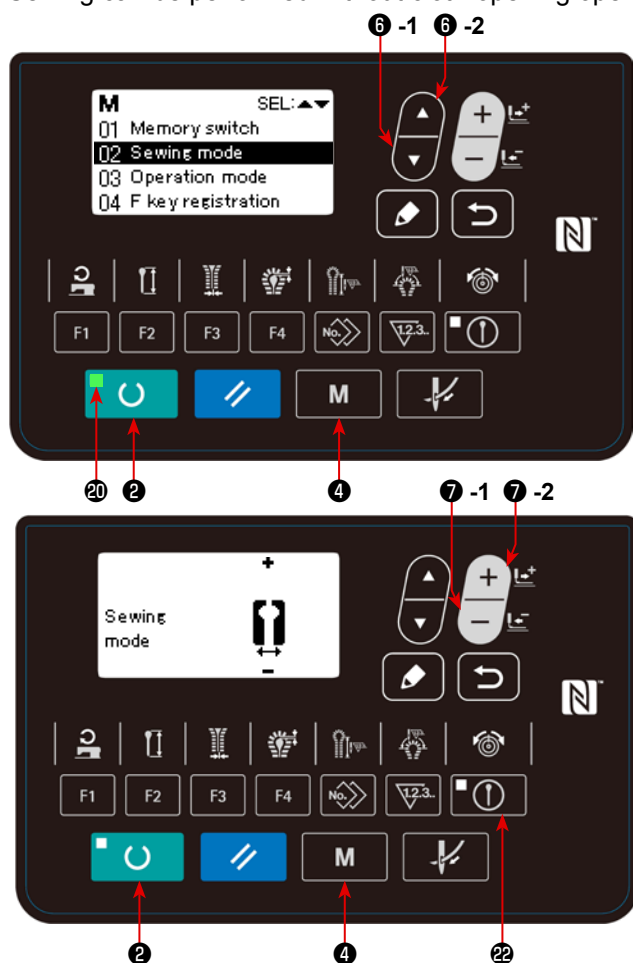

Important If the Sewing LED 20 stays ON, press the Ready key 2 to turn it OFF.

- 1) Press Mode key **M** 4 to display the mode setting screen. Press \downarrow key 6-1 or \uparrow key 6-2 to display "02 Sewing mode".
- 2) Press Ready key **⏻** 2 to display the sewing mode setting screen.
- 3) Set the sewing mode to "Normal", "Re-sewing" or "Cloth open" by pressing $-$ /BACKWARD key 7-1 or $+$ /FORWARD key 7-2.
- 4) Press Ready key **⏻** 2 to finish setting. If you press Mode key **M** 4, the data you have set will be cancelled.
- 5) Press Mode key **M** 4 to return to the normal display.

Sewing machine operation under each sewing mode
(1) Normal mode (the sewing mode is set to "Ⓢ", i.e., the power-on state)

- ① Press the Ready key **⏻** 2 to retrieve the origin of the feed bar/needle bar. In the case memory switch No. 12 "Cloth set position selection" is set to "front", the feed bar travels to the near set position (memory switch No. 23). The cloth open mechanism is closed.

- ② Carry out sewing with the Presser foot switch and the Start switch. When the before-cut knife operates, the cloth open mechanism opens after the completion of the operation of the cloth cutting knife. In the case of the after-cut knife/without knife, the cloth open mechanism opens simultaneously with the start of sewing. The cloth open mechanism closes upon the completion of sewing.

(2) Re-sewing mode (when the Sewing mode is set to "Ⓢ")

- ① Press the Ready key **⏻** 2 to retrieve the origin of the feed bar/needle bar. Even in the case "cloth set position selection" is set to "front", the feed bar keeps resting at the origin of the cloth cutting knife operating position. The cloth open mechanism remains open.
- ② The cloth open mechanism remains open even when sewing is performed with the Presser foot switch and the Start switch.

(3) Cloth open mode (when the Sewing mode is set to "Ⓢ")

- ① Press the Ready key **⏻** 2 to retrieve the origin of the feed bar/needle bar. In the case "cloth set position selection" is set to "front", the feed bar travels to the near set position. The cloth open mechanism remains open.
- ② The cloth open mechanism remains open even when sewing is performed with the Presser foot switch and the Start switch.



1. In the case the cloth cutting knife is not operated, knife operation should be prohibited by means of the Knife ON/OFF key 1 22. Refer to "6-7. When dropping of the knife is temporarily not desired" p. 50 for the procedure.
2. To set the material setting position to the front side, refer to "9-2. Changing the setting position of cloth" p. 86.



Before starting the sewing machine, close the front cover.

6-5. Performing threading





WARNING :

Turn OFF the power after operation of steps 1) and 2), and replace needle, thread, cloth cutting knife or hammer.

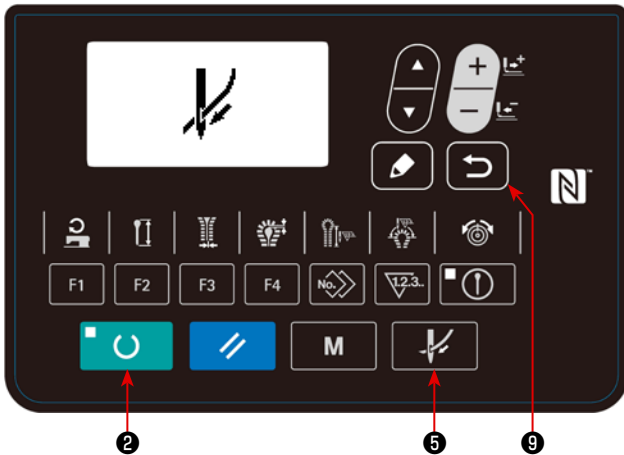

This operation cannot be carried out immediately after power-on. Carry out the following operation after the origin retrieval of the feed bar/needle bar by pressing once the Ready key  ②.



1) Press Threading key  ⑤.

① The presser foot comes down.

② In the case memory switch No. 12 “material setting position selection” is set to the front side, the feed base travels backward (to origin position).

③ The needle bar turns by 180 degrees of an angle to allow threading of the needle bar from the front of the machine head.

2) Press Threading key  ⑤ again. Then, only the needle bar returns to its origin.

3) When RETURN  ⑨ is pressed, the aforementioned ① to ③ return to their home positions.



It is recommended to perform installing/removing the presser unit after operating the aforementioned step 1) and turning OFF the power.





The presser and the feed base operate.

Be careful that hands or fingers are not being caught in them.

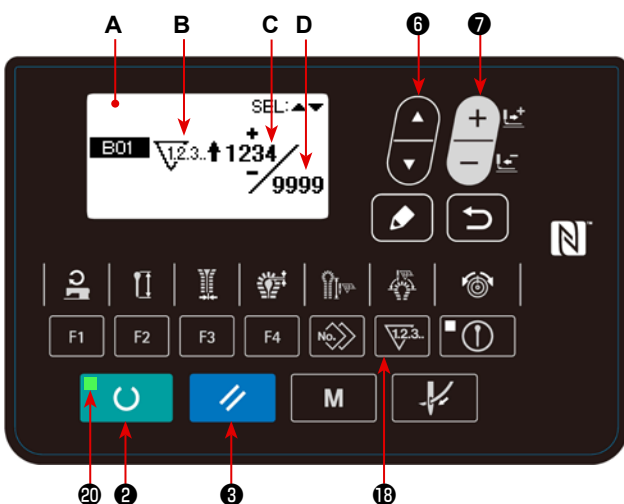

6-6. How to use the counter

(1) Setting procedure of the counter value





If the Sewing LED ⑳ stays ON, press the Ready key  ② to turn it OFF.

1) Call counter setting screen

When COUNTER key  ⑩ is pressed under the input mode where SET READY LED ⑳ goes out, the counter screen A is displayed to enable setting of the counter. Setting of the counter value can be performed only with the input mode. In case of the sewing mode, press READY key  ② to set the mode to the input mode.

2) Selection of kinds of counters

Press ITEM SELECT key  ⑥ to display the pictograph **B** which indicates the counter type in reverse video. Press DATA CHANGE key  ⑦, and select the counter you desire from among the kinds of counters below.

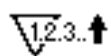

① Sewing UP counter

Every time the sewing of one shape is performed, the existing value is counted up. When the existing value is equal to the set value, count-up screen is displayed.

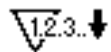



② Sewing DOWN counter

Every time the sewing of one shape is performed, the existing value is counted down. When the existing value is reached to "0", count-up screen is displayed.





③ Counter not used

3) Change of counter set value

Press ITEM SELECT key  ⑥ to display the set value **C** of the counter in reverse video. Press DATA CHANGE key  ⑦ and input the set value until count-up is reached.

4) Change of counter set value

Press ITEM SELECT key  ⑥ to display the current value **D** of the counter in reverse video. Press RESET key  ③ and the value on the way of counting can be cleared. In addition, it is possible to edit the numerical value with DATA CHANGE key  ⑦.



The counter has been factory-set to "① Sewing UP counter" at the time of delivery. This counter has been factory-set so that it stops counting after the number of times of start of sewing machine has reached 100. Set this counter according to your conditions of use.

(2) Count-up releasing procedure



When count-up condition is reached during sewing work, the whole count-up screen **E** flashes on and off. Press RESET key  ③ to reset the counter, and the mode returns to the sewing mode. Then the counter starts counting again.

6-7. When dropping of the knife is temporarily not desired

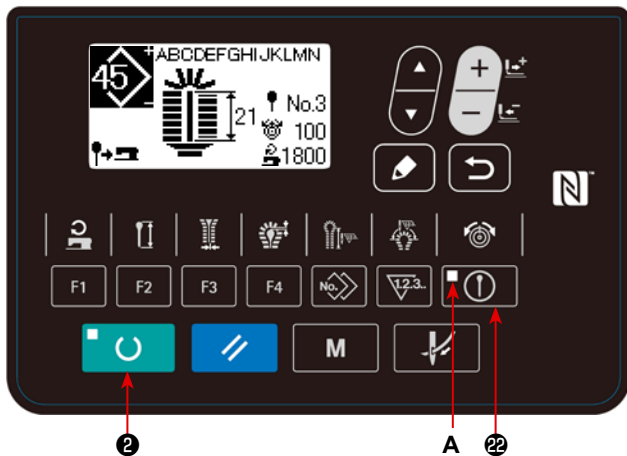

- 1) Press TRIMMER ON / OFF key **1** **22** to turn OFF the LED A.
- 2) Press TRIMMER ON / OFF key **1** **22** again to turn ON the LED A. Then, the cloth trimmer operation is enabled.

1. Set enable/disable of the before-cut knife/after-cut knife using data S003 "Before-cut knife/after-cut knife" of the pattern data.



2. In the case the data S003 "Before-cut knife/after-cut knife" of the pattern data is set to "disable", the Before-cut knife LED A and After-cut knife do not light up.

6-8. Changing the operation mode

The sewing operation of the sewing machine can be carried out by manual operation/step operation.

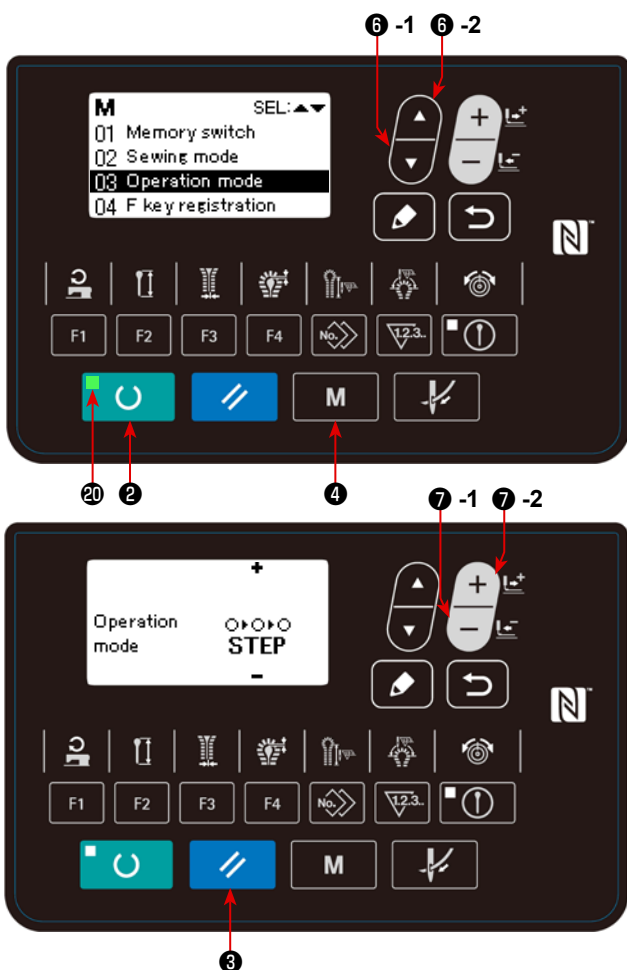

Important If the Sewing LED **20** stays ON, press the Ready key **2** to turn it OFF.

- 1) Press Mode key **M** **4** to display the mode setting screen. Press -/BACKWARD key **-** **7-1** or +/FORWARD key **+** **7-2** to display "03 operation mode".
- 2) Press Ready key **2** to call the operation mode setting screen.
- 3) Press -/BACKWARD key **-** **7-1** or +/FORWARD key **+** **7-2** to set the operation mode to "Normal", "Manual" or "Step".
- 4) Press Ready key **2** to finish setting. If you press Mode key **M** **4**, the data you have set will be canceled.
- 5) Press Mode key **M** **4** to return to the normal display.

Sewing machine operation under each operation mode

(1) NORMAL mode (when the operation mode is set to "🌀" and the power is ON)



Operation is carried out under the normal operation mode where the cloth cutting knife is activated and a sewing sequence such as sewing and thread trimming is carried out by operating the Presser foot switch and the Start switch.



Before starting the sewing machine, close the front cover.

(2) MANUAL mode (when the operation mode is set to "👉")

Operate the Presser foot switch to lower the presser foot. Then, the operation is carried out as described below.

- ① In the case of the before-cut knife is selected, the feed base is brought to its origin, when it is not there by operating the Start switch.
- ② In the case of the before-cut knife is selected, the cloth cutting knife is activated by operating the Start switch.
- ③ The cloth open mechanism is opened by operating the Start switch.
- ④ The presser foot is lowered by pressing the start switch.
- ⑤ The feed base is brought to the sewing starting position by operating the Start switch. Then, the buzzer sounds.
- ⑥ Turn the pulley in the direction of the arrow. The feed base is travels stitch by stitch in conjunction with the needle position. Keep the pulley turning until the sewing end position is reached. Then, the buzzer sounds. It is also possible to move only the feed base by means of -/BACKWARD key  7-1 or +/FORWARD key  7-2.



Be sure to turn the handwheel in the normal direction since the feed mechanism does not perform the receding operation even when the handwheel is turned in the reverse direction.

- ⑦ The feed base is brought to its origin and the needle thread trimming operation is carried out by operating the Start switch.
- ⑧ When the after-cut knife is selected, the cloth cutting knife is activated by operating the Start switch.
- ⑨ For the general thread trimming type machine, the bobbin thread trimming operation is carried out by operating the Start switch.
- ⑩ The needle bar is brought to its origin and the cloth open mechanism is closed by operating the Start switch.
- ⑪ To terminate sewing before it is completed, press Reset key  3 to bring the feed base to the set position.



Before starting the sewing machine, close the front cover.

(3) STEP mode (when the operation mode is set to "🔲 STEP")

After you have lowered the presser foot by operating the Presser foot switch, the sewing machine operates in the same way as described in steps ① to ④ and ⑥ to ⑩ under (2) MANUAL mode. Only step ⑤ is different from the MANUAL mode. In the MANUAL mode, the feed base travels stitch by stitch by turning the pulley by hand. On the other hand, in the STEP mode, the following operation is carried out by operating the Start switch.

- ⑤ The sewing machine carries out the normal sewing operation and stops at the sewing end.



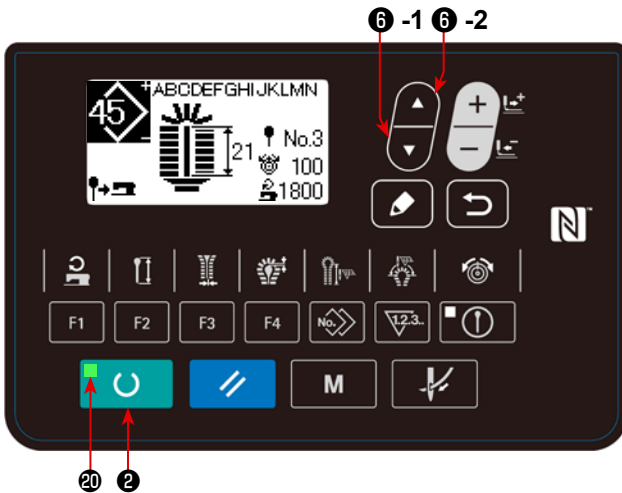

Before starting the sewing machine, close the front cover.

6-9. Changing procedure of the sewing pattern





Important If the Sewing LED 20 stays ON, press the Ready key  2 to turn it OFF.

- 1) Select pattern No. that you want to sew by pressing - / BACKWARD key  7-1 or + / FORWARD key  7-2.
- 2) Press READY key  2 to light up sewing LED 20 and to make it possible to sew. At this time, the presser foot comes down and the feed base and needle bar retrieve the respective origins.

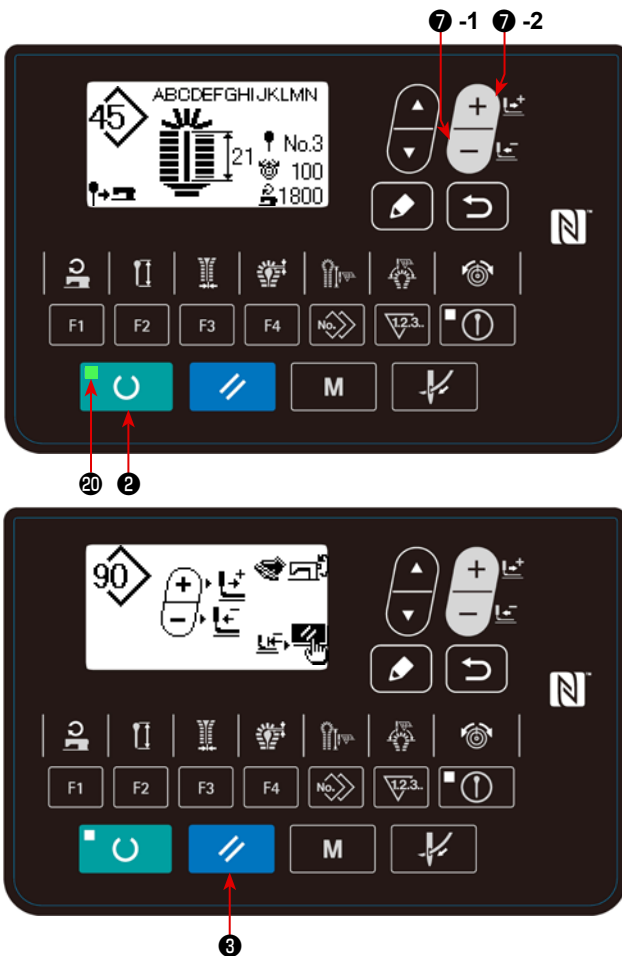

Caution The presser and the feed base operate. Be careful that hands or fingers are not being caught in them.

6-10. Confirming the pattern shape



- 1) Press READY key  2 to light up sewing LED 20 and to make it possible to sew. At this time, the presser foot comes down and the feed base and needle bar retrieve the respective origins.

Caution The presser and the feed base operate. Be careful that hands or fingers are not being caught in them.

- 2) Operate the Presser foot switch to lower the presser foot.
- 3) When you press -/BACKWARD key  7-1 or +/FORWARD key  7-2, the feed travels stitch by stitch until the sewing end is reached. When you keep the key held pressed, the feed continuously travels.
- 4) After you have confirmed the pattern shape, press Reset key  3 to bring the feed to the material setting position.

Caution If the START switch is pressed during confirmation of the pattern shape, sewing starts from the position where the switch is pressed. So, be careful.

Caution Before starting the sewing machine, close the front cover.

7. SETTING PROCEDURE OF THE SEWING DATA

In the case the sewing machine stops with its needle-bar rested in any position other than the upper end when the READY key  ② is pressed, Error (E030) will occur to stop the sewing machine.

In this case, turn the hand pulley to move the needle bar to its upper stop position. Error (E030) will disappear when the upper stop position is reached. In this state, press the READY key  ② again to light up sewing LED ⑳.



In addition, the needle bar will automatically return to the upper stop position when you press the READY key  ② even in the case the needle bar is not brought to its upper stop position as long as the needle bar rests at any position between the upper stop position and a point short of the lower dead point.







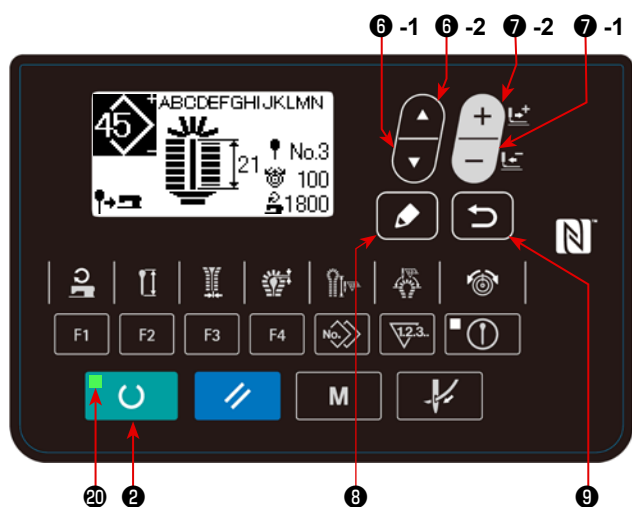

For the standard sewing patterns No. 88 to No. 99, the sewing speed and the thread tension can be changed. However, the pattern shape cannot be changed. To change the pattern shape, you have to copy the pattern to a different pattern number.



Refer to "9-6. How to copy / delete the sewing pattern" p. 87 for the procedure.



Important If the Sewing LED ⑳ stays ON, press the Ready key  ② to turn it OFF.

- 1) Select the pattern number that you want to change its sewing data by pressing - / BACKWARD key  ⑦-1 or + / FORWARD key  ⑦-2.
- 2) Press EDIT  ⑧ to display the data set value.
- 3) Select the data number by pressing ▼ key  ⑥-1 or ▲ key  ⑥-2 to display its data set value.
- 4) Press -/BACKWARD key  ⑦-1 or +/FORWARD key  ⑦-2 to set a new set value C of data.
- 5) Press Ready key  ② to light up Sewing LED ⑳. At this time, the sewing data is stored in memory. At the same time, the presser foot comes down and the feed base and needle bar retrieve the respective origins.

1. If you change the pattern number without pressing Ready key  ② in the aforementioned step 5), or turn the power off, the set value you have input will not be stored in memory.
2. The presser and the feed base operate. Be careful that hands or fingers are not being caught in them.



- 6) Press RETURN key  ⑨ to return the current display to the normal display.



It is possible to prohibit the data setting from being changed in the aforementioned step 4) by setting memory switch No. 16 "Data setting prohibition" to "1". Refer to "13. MEMORY SWITCH" p. 117 for the procedure.

* The data No. is stated in 2-digit LED B and the example of the set value is stated in 4-digit LED C as shown below.

- The setting range is stated in the respective sentences.
- Corrected stitches are represented by the stitch shape as observed from the right side of the material.

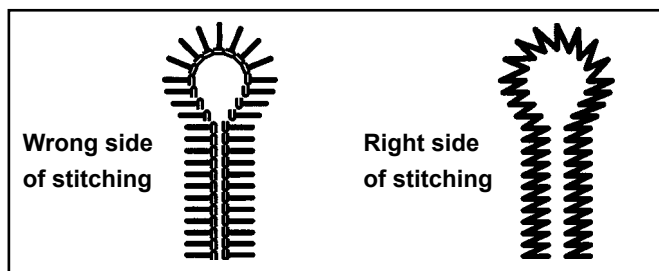

7-1. Setting the knife No.

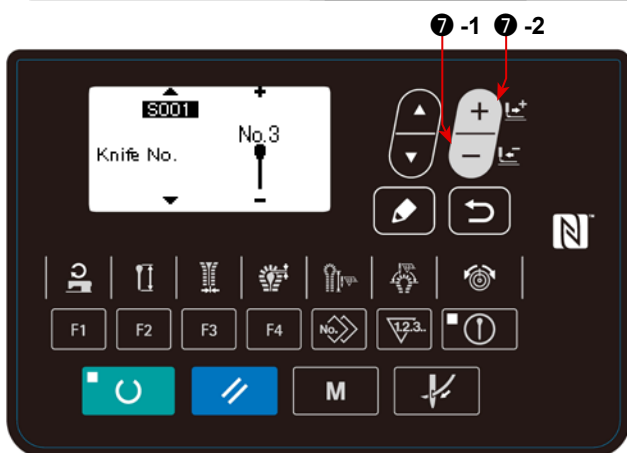

Set the knife No. of the same shape as that of the knife mounted on the sewing machine.

Set the knife number by means of –/BACKWARD key

7-1 or +/FORWARD key 7-2.

The No. can be set 0 to 6.

The number of the cloth cutting knife which is provided as standard is "3". For optional knives, refer to "11-4. Cloth cutting knife" p. 113.

* In the case "No. 7 for radial stitch eyelet" is selected, the knife size should be set to the set value of "S094 Radial stitch eyelet diameter".

0 ... Decorative buttonhole

1 to 6 ... Eyelet buttonhole

No.	a×b
1	2.1 × 3.2
2	2.5 × 3.8
3	2.9 × 4.4
4	3.0 × 4.6
5	3.2 × 5.4
6	2.7 × 5.1
7	For radial stitch eyelet (*)

7-2. Setting the cut length

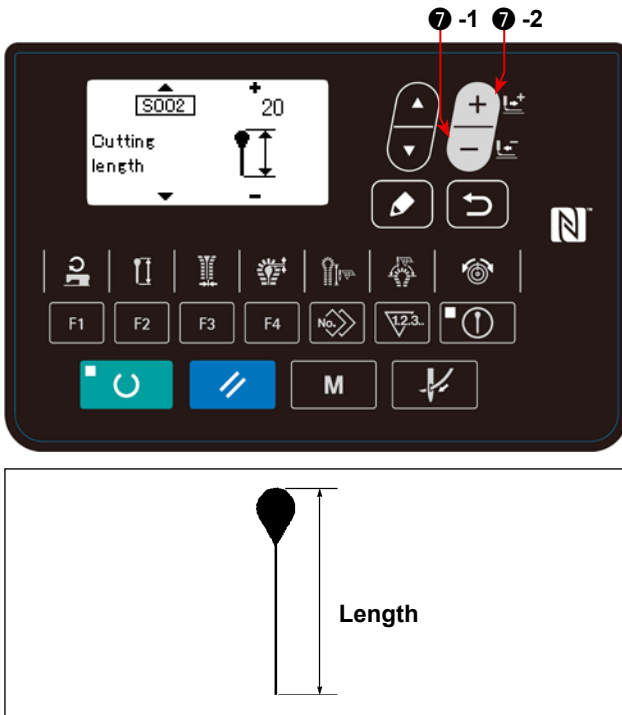

Set the length to be cut with the knife.

Set the knife number by means of –/BACKWARD key 7-1 or +/FORWARD key 7-2.

The cloth cutting length can be set in increments of 1 mm within the range given in the table below according to the type of sewing machine.

Type of sewing machine	Type of thread trimmer	Eyelet button hole setting range	Lockstitch buttonhole setting range
J type	Needle thread trimming type	10 to 38mm	5 to 38mm
	General thread trimming type	10 to 34mm	5 to 34mm
C type	Needle thread trimming type	10 to 38mm	5 to 38mm
	General thread trimming type	10 to 34mm	5 to 34mm



1. When the cut length is changed, the number of stitches of the parallel section will automatically change.
2. When you set the cloth cutting length, it is necessary to set a value obtained by adding a sewing length to be extended to the length of the hammer used.
3. When sewing length is lengthened in case of taper bar length, compensation at the sewing end, etc., the setting range of the cut length is decreased as much as the length.
Example) Cut length + (plus) taper bar length ≤ 38 mm (long thread trimming)

7-3. Setting the cut-before/cut-after knives

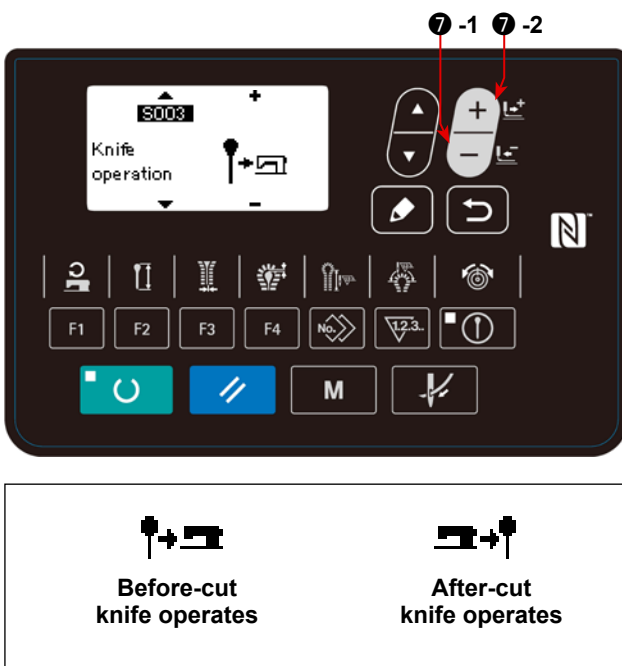

Set whether the cut-before knife or the cut-after knife.

Set the knife number by means of –/BACKWARD key 7-1 or +/FORWARD key 7-2.

The knife can be set within the range given in the table below.

Set value	Cloth cutting knife operation
	Without knife
	Before-cut knife
	After-cut knife

Before-cut knife operates

After-cut knife operates

7-4. Setting the number of stitches of the parallel section

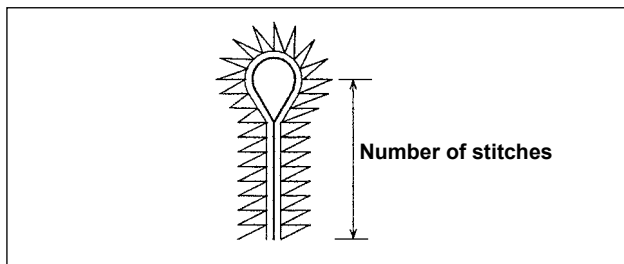
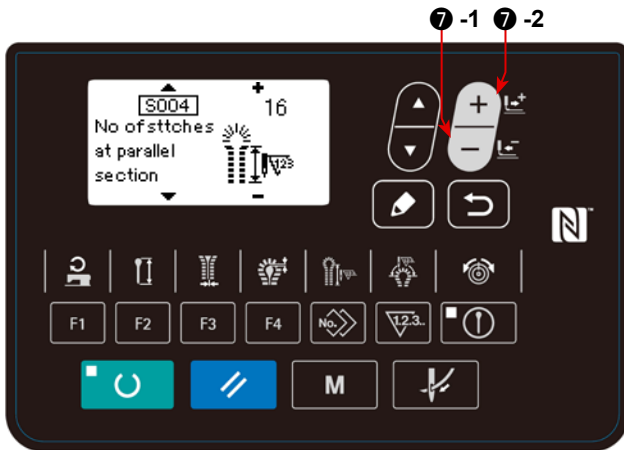

Set the number of stitches from the parallel section to the bottom section of eyelet.

Set the knife number by means of **-/BACKWARD** key **7-1** or **+/FORWARD** key **7-2**.

The number of stitches can be set, according to the cutting length, using any of the stitch lengths within the range from 0.5 to 4 mm.

Example) In the case the cutting length is 21 mm, the number of stitches that can be set is 5 to 39.

Caution When the number of stitches is small, the sewing speed is automatically reduced.

7-5. Setting the number of stitches of the eyelet

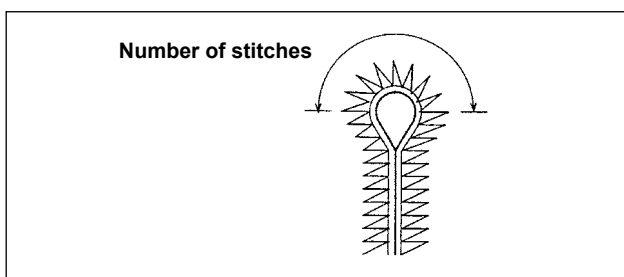
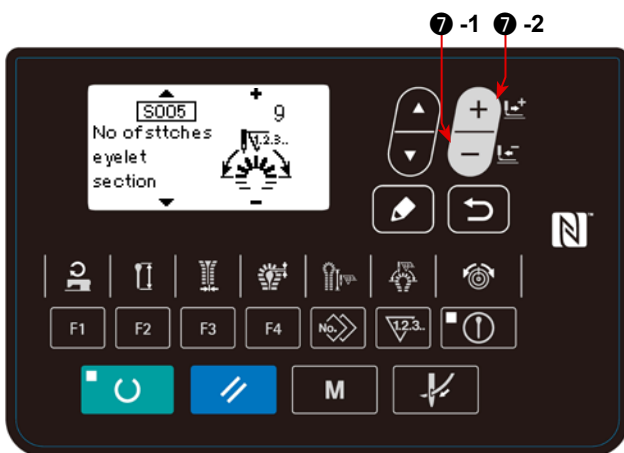

Set the number of stitches of the top section of eyelet.

Set the knife number by means of **-/BACKWARD** key **7-1** or **+/FORWARD** key **7-2**.

The number of stitches can be set 3 to 20 stitches.

Caution When the number of stitches is small, the sewing speed is automatically reduced.

7-6. Setting the cut space

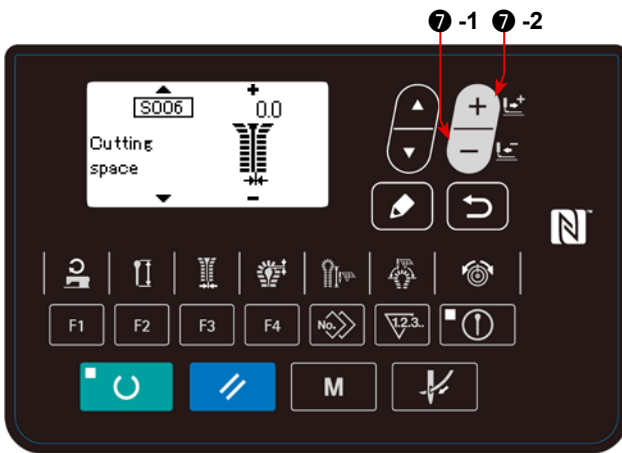

Set the clearance where the knife drops in the parallel section.

Set the knife number by means of **-/BACKWARD** key **7-1** or **+ /FORWARD** key **7-2**.

The space can be set -1.2 to 1.2 mm in the increments of 0.1 mm.

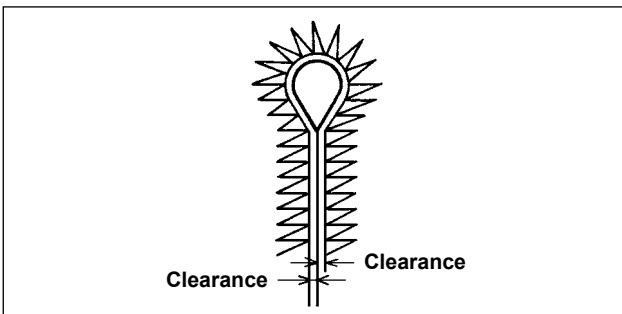

7-7. Setting the eyelet space

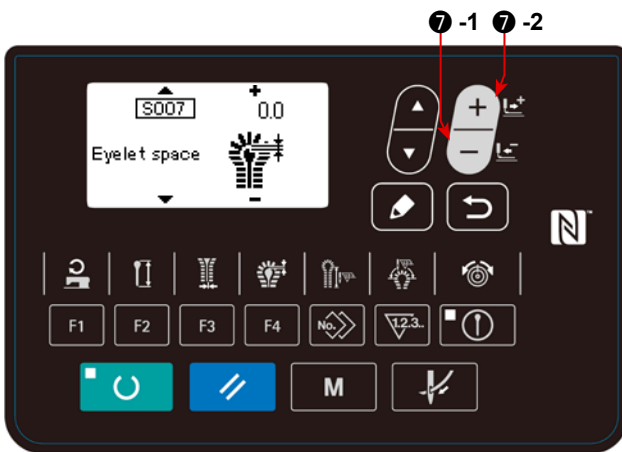

Set the clearance where the knife drops in the eyelet section.

Set the knife number by means of **-/BACKWARD** key **7-1** or **+ /FORWARD** key **7-2**. The space can be set -1.2 to 1.2 mm in the increments of 0.1 mm.

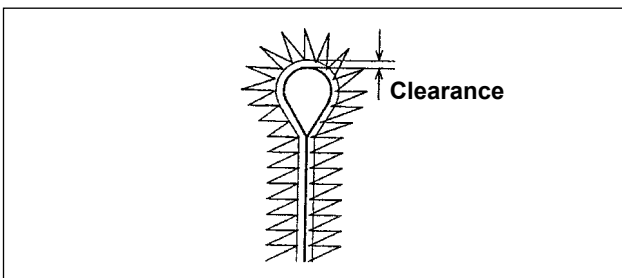

7-8. Knife position compensation

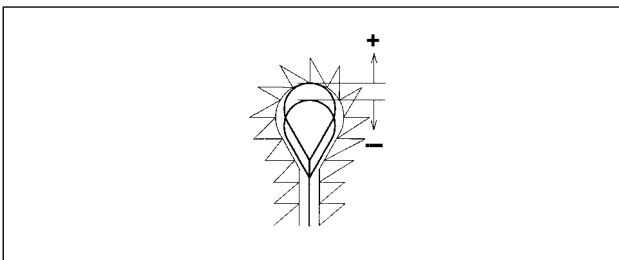
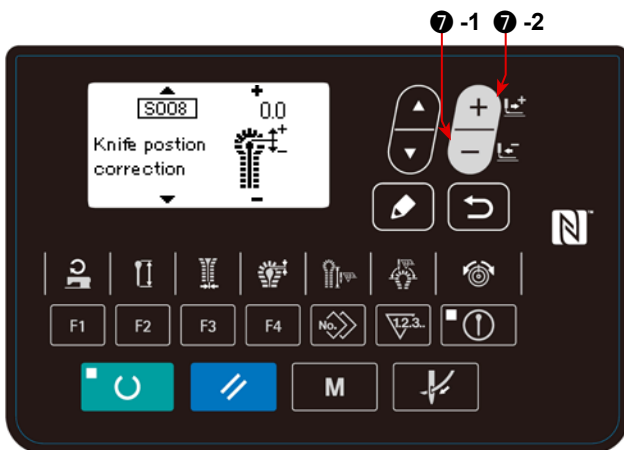

Correct the slip between the position of knife and sewing position.

Set the knife number by means of **-/BACKWARD** key **7-1** or **+/FORWARD** key **7-2**.

Setting can be performed – 0.7 to 0.7 mm in the increments of 0.1 mm.

When the knife position in terms of the stitches is desired to be placed in the rear side, set “+” (plus) value, and in the front side, set “–” (minus) value.

7-9. Number of stitches of sewing end compensation

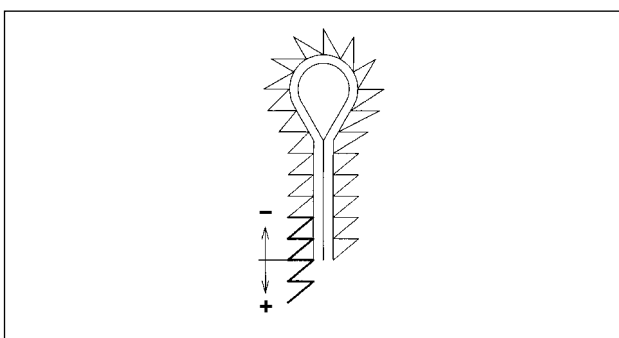
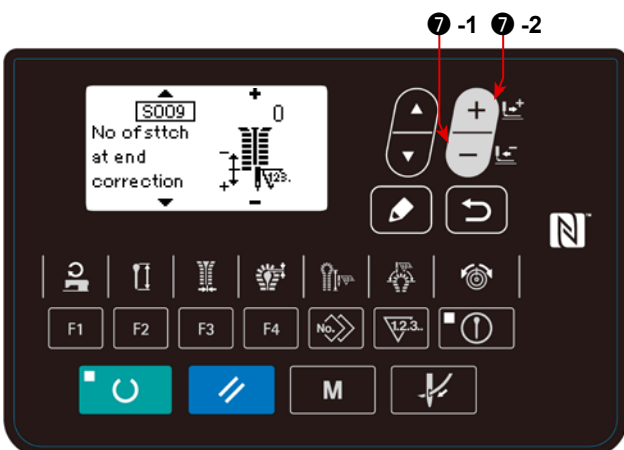

Number of stitches of sewing end can be increased at the same sewing pitch.

Set the knife number by means of **-/BACKWARD** key **7-1** or **+/FORWARD** key **7-2**.

Without bartack–1 to 6 stitches

Taper bar–1 to 6 stitches

Straight bar..... –1 to 3 stitches

Round bar.....–1 to the number of stitches of round bar on the right side at the beginning of sewing

Round bar 2.....0 stitch

7-10. Turning angle compensation

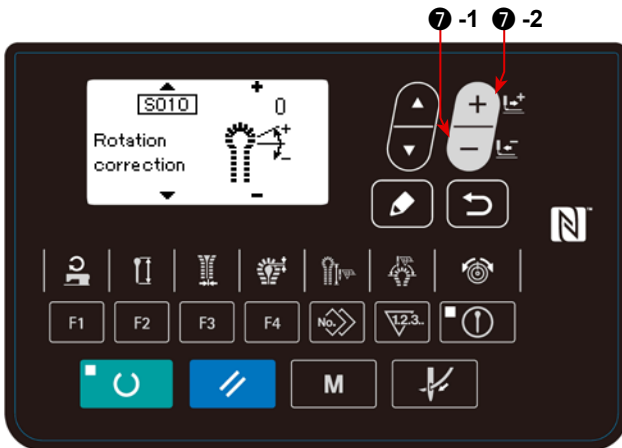

Turning angle of the eyelet section and of the parallel section can be adjusted.

Set the knife number by means of –/BACKWARD key

7-1 or +/FORWARD key **7-2**.

Setting can be performed -14° to 14° .

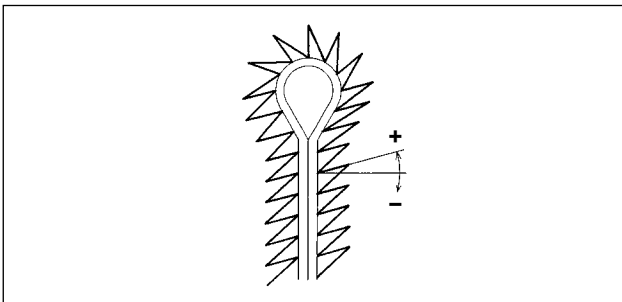

7-11. Turning angle compensation at the parallel section

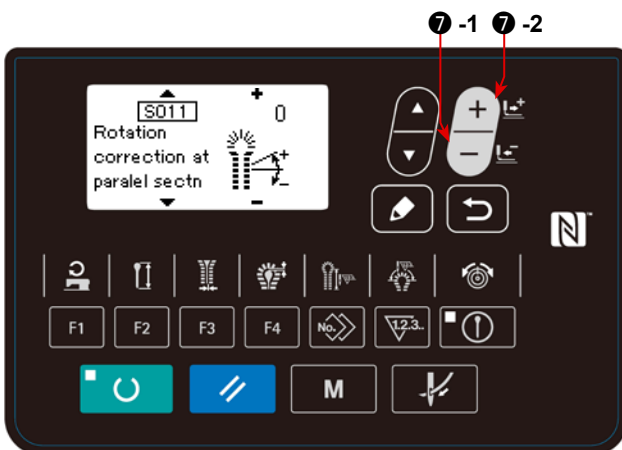

Turning angle of parallel section and bottom of eyelet can be adjusted.

Set the knife number by means of –/BACKWARD key

7-1 or +/FORWARD key **7-2**.

If the turning angle compensation is carried out as described in "7-10. Turning angle compensation", the turning angle at the parallel section of a buttonhole will be adjusted in such a way as to add this set value to the compensation set in 7-10.

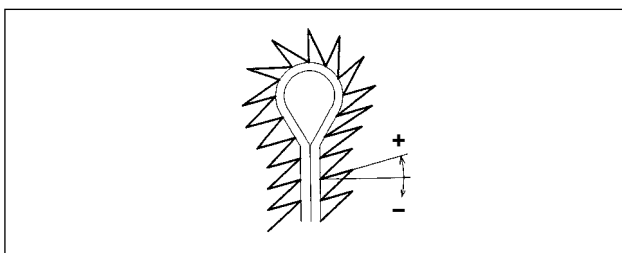

It is possible to set the angle compensation in the range of $-14^{\circ} \leq \text{turning angle compensation} + \text{turning angle compensation at the parallel section} \leq 14^{\circ}$.

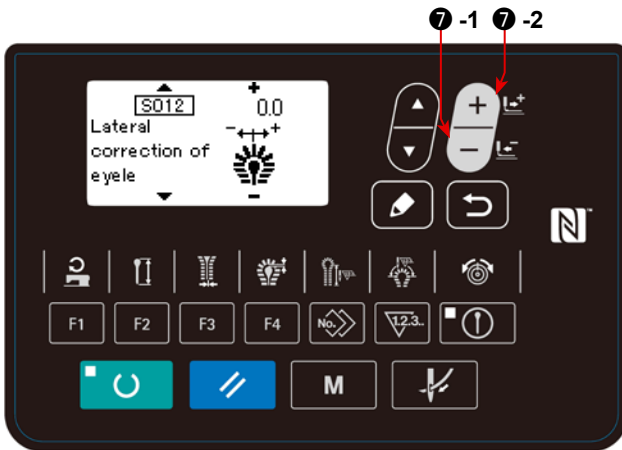

7-12. Compensation of eyelet in lateral direction



Position on the top of eyelet can be moved to the right- or left-hand.

Set the knife number by means of **-/BACKWARD** key  **7-1** or **+/FORWARD** key  **7-2**.

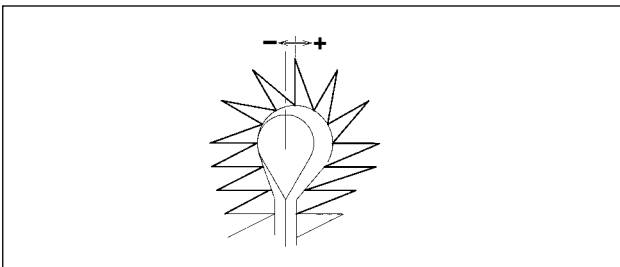

Setting can be performed -0.6 to 0.6 mm in the increments of 0.1 mm.

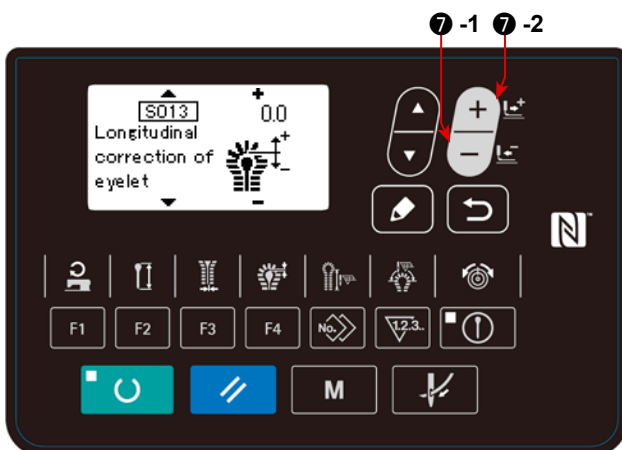

7-13. Compensation of eyelet in longitudinal direction



Shape on the top of eyelet can be expanded or contracted in the longitudinal direction.

Set the knife number by means of **-/BACKWARD** key  **7-1** or **+/FORWARD** key  **7-2**.

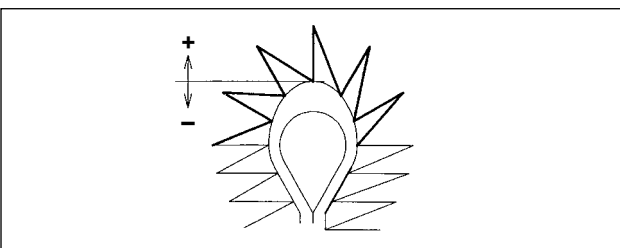

Setting can be performed -0.2 to 0.6 mm in the increments of 0.1 mm.

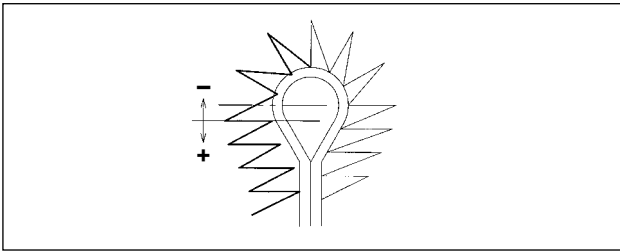
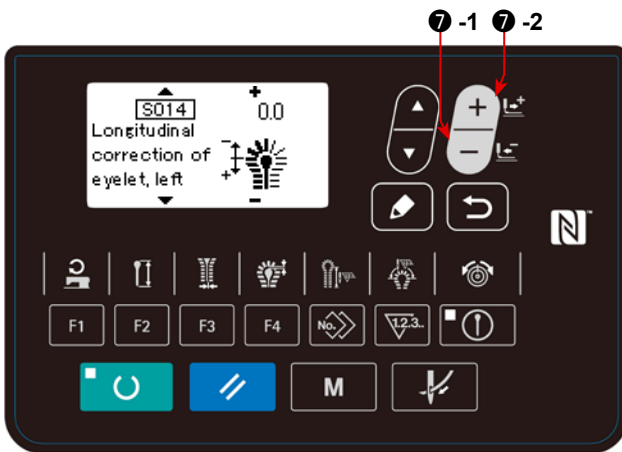

7-14. Compensation of eyelet, left in longitudinal direction



Length of the left side on the top of eyelet can be adjusted.



Set the knife number by means of **-/BACKWARD** key  **7-1** or **+/FORWARD** key  **7-2**.

Setting can be performed -0.2 to 0.6 mm in the increments of 0.1 mm.

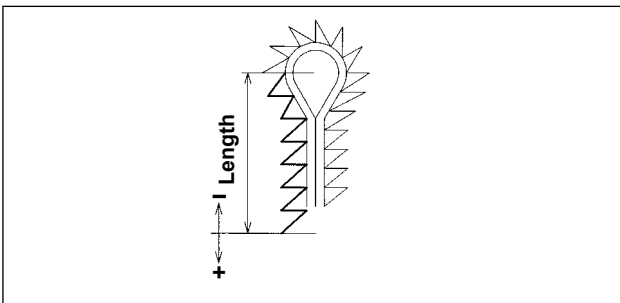
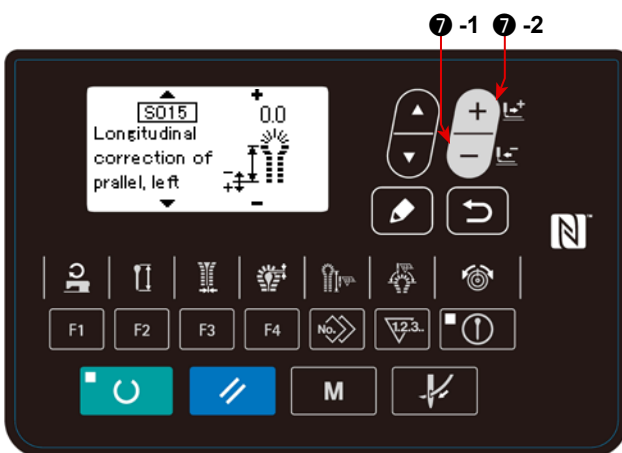
7-15. Compensation of left parallel section of a buttonhole



Length from the bottom of eyelet to the left side of parallel section can be adjusted.

Set the knife number by means of **-/BACKWARD** key  **7-1** or **+/FORWARD** key  **7-2**.

Setting can be performed -0.6 to 0.6 mm in the increments of 0.1 mm.

7-16. Compensation of cutting space, left

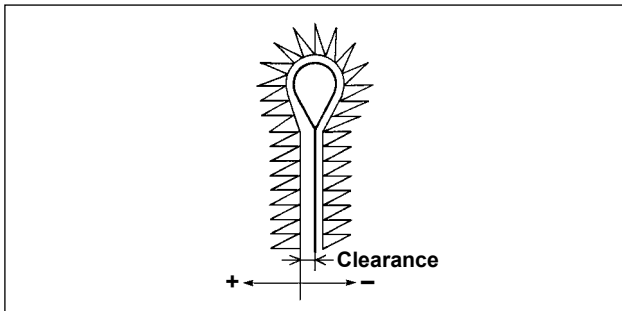
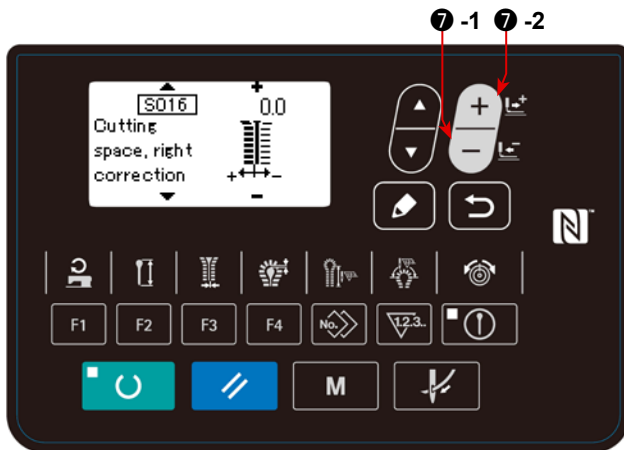

The clearance where the knife drops in the left side of the parallel section can be compensated.

Set the knife number by means of $-$ /BACKWARD key 7-1 or $+$ /FORWARD key 7-2.

Compensation is carried out in such a way as to add this set value to the value of Data No.6 "Cutting space setting".

If the setting is "+", the clearance becomes larger than that on the right side, and if it is "-", the clearance becomes smaller.

The cutting space, left can be set in increments of 0.1 mm within the range of $-1.2 \leq \text{cutting space} + \text{cutting space left, compensation} \leq 1.2 \text{ mm}$.

7-17. Setting the needle throwing width of the right bottom of eyelet

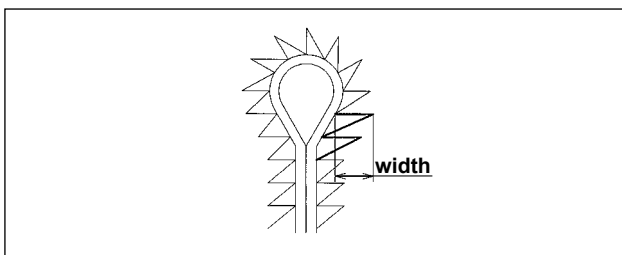
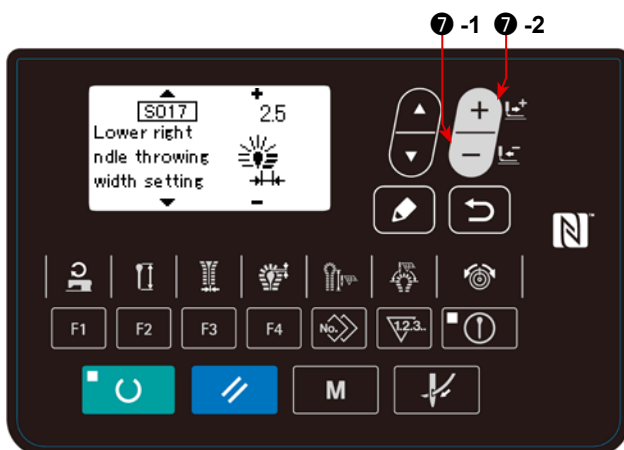

Needle throwing width of the right side of the bottom of eyelet can be set.

Feed base is actuated with the needle throwing to change the sewing width.

Set the knife number by means of $-$ /BACKWARD key 7-1 or $+$ /FORWARD key 7-2.

It can be set in increments of 0.1 mm within the range of $2.5 \text{ mm} \pm 1.0 \text{ mm}$.

7-18. Setting the needle throwing width of the left bottom of eyelet

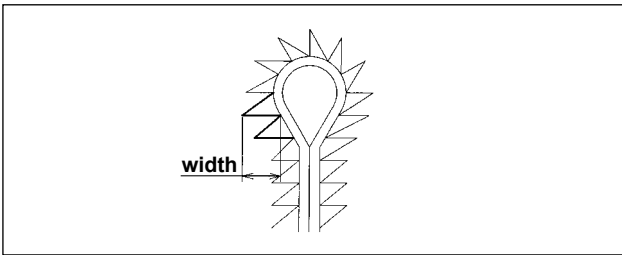
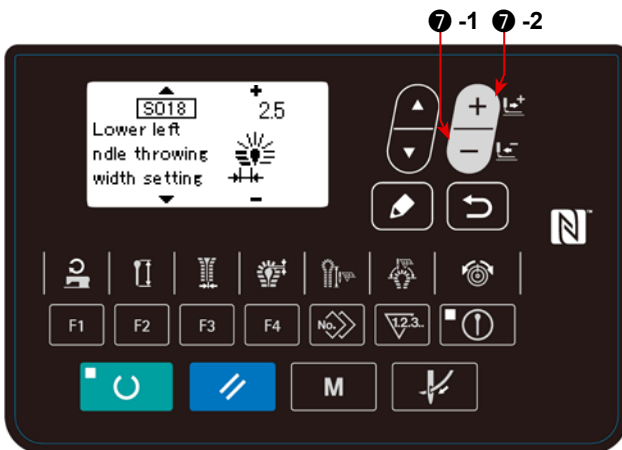

Needle throwing width of the left side of the bottom of eyelet can be set.

Feed base is actuated with the needle throwing to change the sewing width.

Set the knife number by means of **-/BACKWARD** key **7-1** or **+/FORWARD** key **7-2**.

It can be set in increments of 0.1 mm within the range of 2.5 mm \pm 1.0 mm.

7-19. Setting the needle throwing width

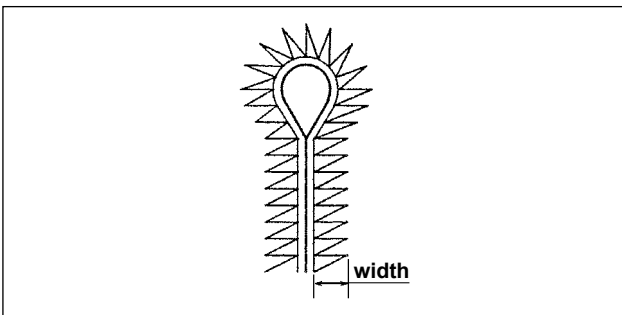
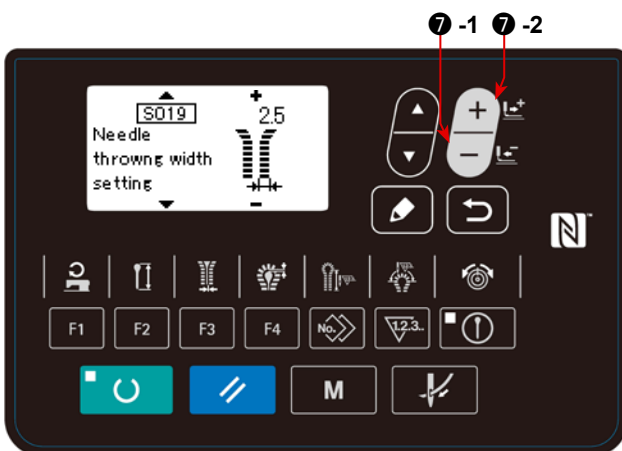

Needle throwing widths at the parallel section and at taper section of a buttonhole are set.

Feed base is actuated with the needle throwing to change the sewing width.

Set the knife number by means of **-/BACKWARD** key **7-1** or **+/FORWARD** key **7-2**.

It can be set in increments of 0.1 mm within the range of 2.5 mm \pm 1.0 mm.



To change the stitch bite width for the normal use of the sewing machine, adjust the sewing machine referring to **"8-2. Adjusting the stitch bite width"** p. 76. To change the stitch bite width temporarily, change the set value.

7-20. Setting the type of bartack

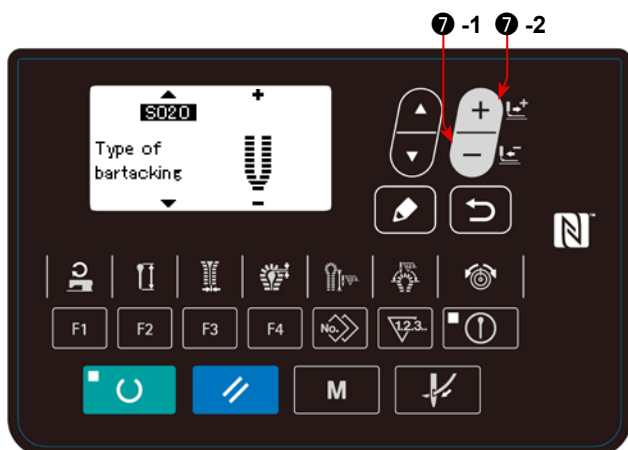

In this step of procedure, the type of bartack is to be set.

Set the knife number by means of **-/BACKWARD** key

7-1 or **+/FORWARD** key **7-2**.

The type of bartack can be set within the range from 0 to 4 as shown in the table below.

Set value	Type of bartack
0	Without bartack
1	Taper bar
2	Straight bar
3	Round bar
4	Round bar 2

	0	1	2	3	4
Type	Without bartack	Taper bar	Straight bar	Round bar	Round bar 2
Shape					
S : Starting position of sewing					

7-21. Setting the length of taper bar

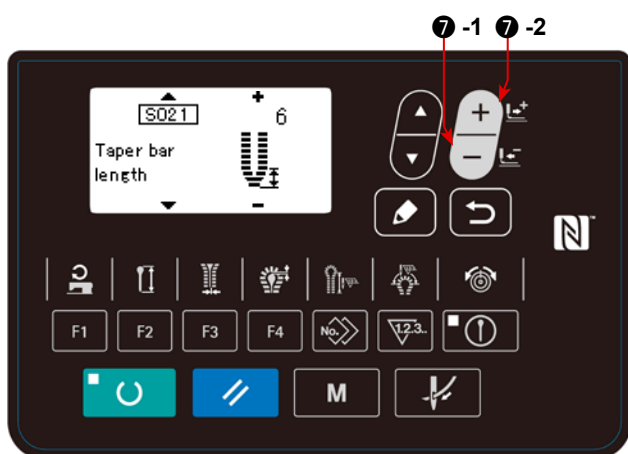

Set the length of taper bar.

Set the knife number by means of **-/BACKWARD** key

7-1 or **+/FORWARD** key **7-2**.

The taper bar length can be set in increments of 1 mm in the range from 3 to 15 mm.

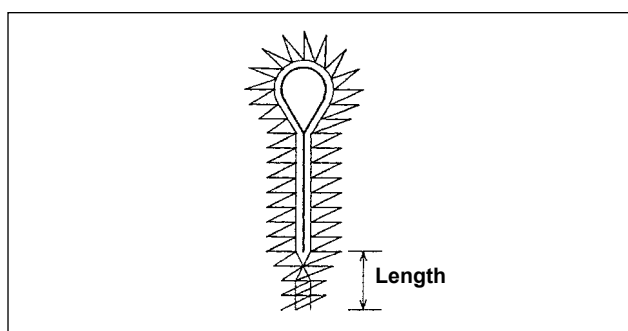

7-22. Setting the number of stitches of taper bar

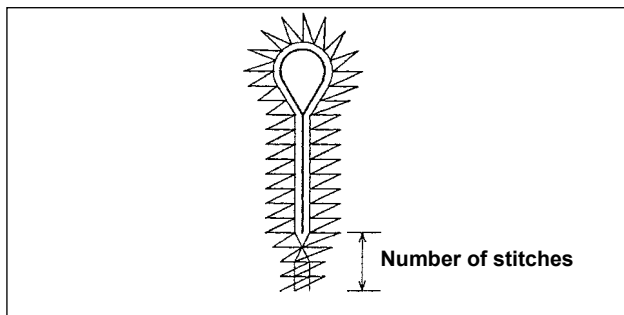
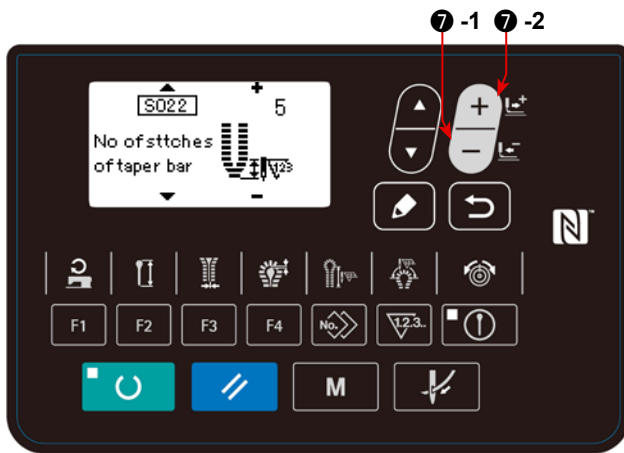

Set the number of stitches of taper bar.

Set the knife number by means of –/BACKWARD key

7-1 or +/FORWARD key **7-2**.

The number of stitches can be set according to the taper bar length using the range of stitch length from 0.5 to 4 mm.

Example) When the taper bar length is 6 mm, the number of stitches can be set in the range from two to 12.

Caution When the number of stitches is small, the sewing speed is automatically reduced.

7-23. Setting the offset of taper bar

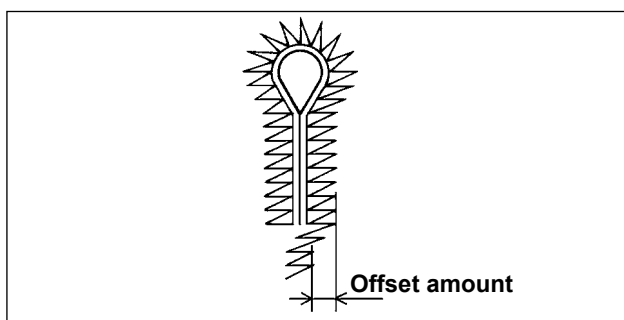
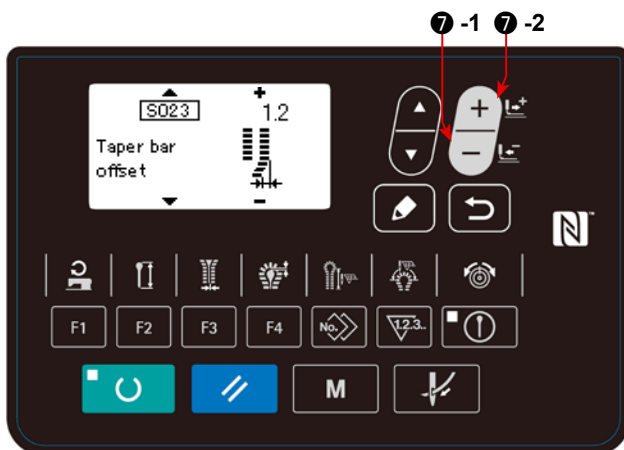

Set the offset amount from the center of taper bar.

Set the knife number by means of –/BACKWARD key

7-1 or +/FORWARD key **7-2**.

The offset amount can be set 0.5 mm to 2.0 mm in the increments of 0.1 mm.

7-24. Setting the number of stitches of slant section of taper bar

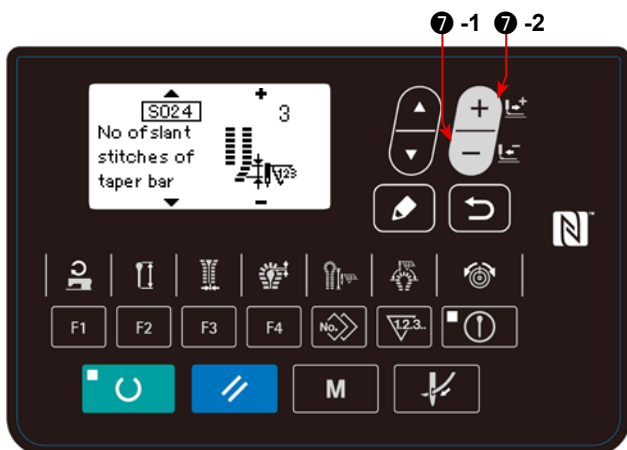

Number of stitches of the slant section from the taper bar to the parallel section can be set.

Set the knife number by means of **-/BACKWARD** key **7-1** or **+/FORWARD** key **7-2**.

The number of stitches can be set in the range from two to (the number of stitches of taper bar).

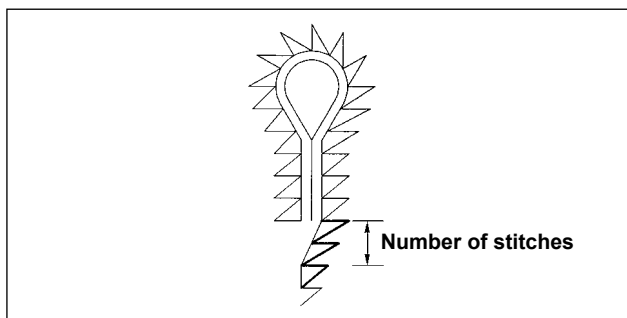

7-25. Compensation of the number of stitches of the right side taper bar

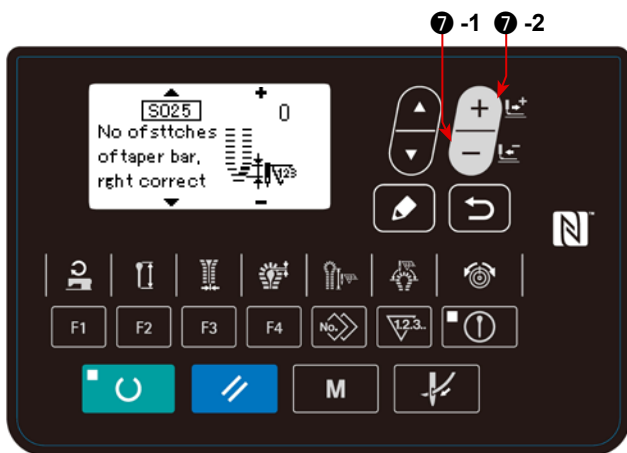

Number of stitches of the right side taper bar can be decreased and the overlapping section can be made less.

Set the knife number by means of **-/BACKWARD** key **7-1** or **+/FORWARD** key **7-2**.

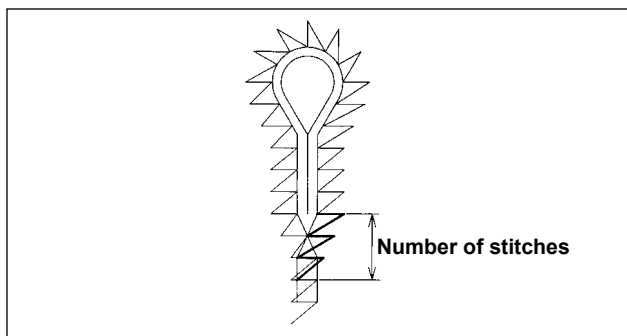

The number of stitches can be set in the range from – (the number of stitches of taper bar) to 0 (zero).



7-26. Setting the straight bar length



In this step of procedure, the length of straight bar is to be set.

Set the knife number by means of –/BACKWARD key  7-1 or +/FORWARD key  7-2.

The straight bar length can be set in increments of 0.1 mm in the range from 2.0 to 10.0 mm.



The straight bar length should be set so that the throat plate and the eyelet presser support plate do not interfere with each other, in consideration of the position of the presser plate when the cloth opening mechanism is opened.

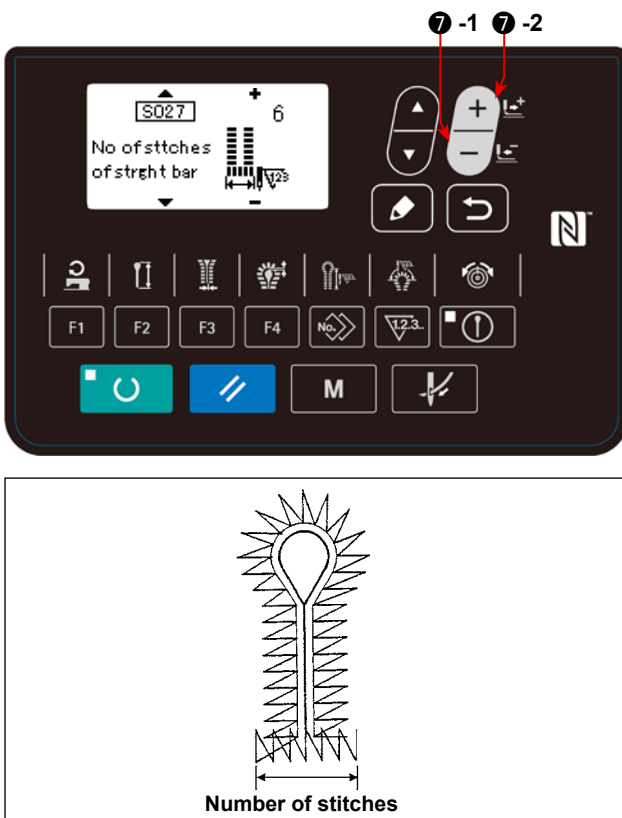

7-27. Setting the number of stitches of straight bar



In this step of procedure, the number of stitches of straight bar is to be set.

Set the knife number by means of –/BACKWARD key  7-1 or +/FORWARD key  7-2.

The number of stitches can be set according to the straight bar length using the stitch length within the range from 0.5 to 4 mm.

Example) When the straight bar length is 5 mm, the number of stitches can be set in the range from three to 11 stitches.

When the number of stitches is small, the sewing speed is automatically reduced.



7-28. Setting the overlapping amount of straight bar

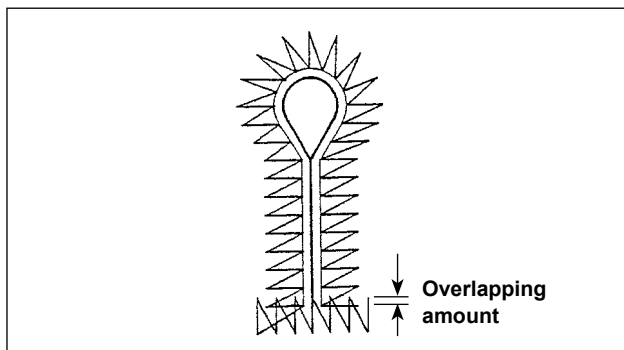
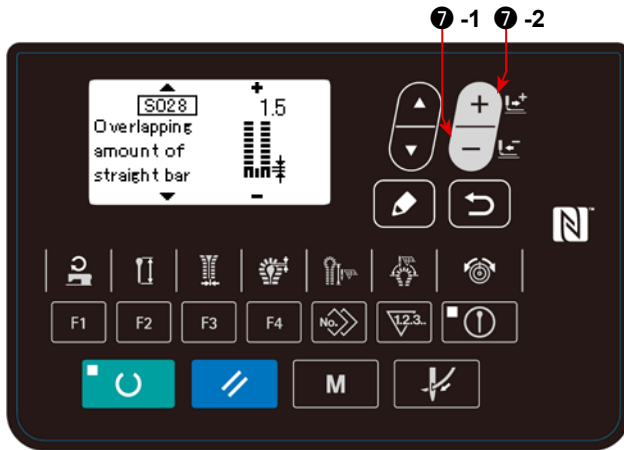

In this step of procedure, the overlapping amount between the straight bar and parallel section is to be set.

Set the knife number by means of $-$ /BACKWARD key **7-1** or $+$ /FORWARD key **7-2**.

The straight bar length can be set in increments of 0.1 mm in the range from 0.0 to 2.0 mm.

Caution The cutting length should be set to a value which is equal to or more than the length that is obtained by adding the overlapping length to the length of the hammer used.

7-29. Setting the needle throwing width of straight bar

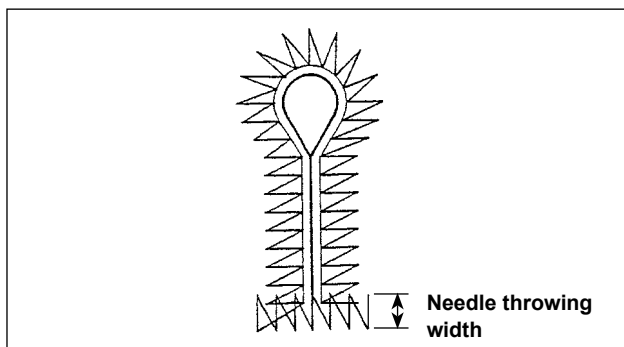
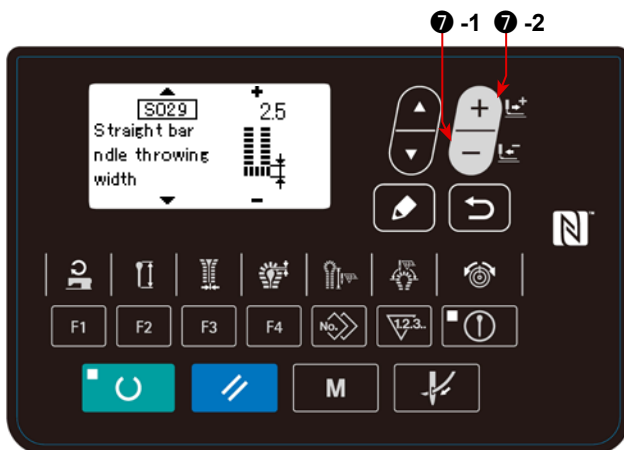

In this step of procedure, the needle throwing width of the straight bar is to be set.

Change the stitch width by operating the feed base along with the needle throwing operation.

Set the knife number by means of $-$ /BACKWARD key **7-1** or $+$ /FORWARD key **7-2**.

The needle throwing width can be set in increments of 0.1 mm within the range of 2.5 ± 1.0 mm.

7-30. Setting the number of stitches of round bar

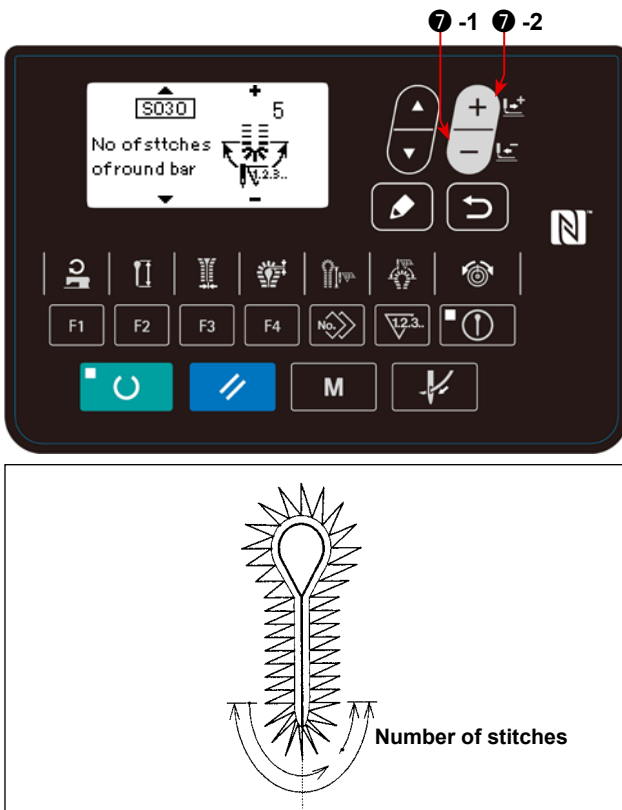

The number of stitches of the round bar is set.

Set the knife number by means of –/BACKWARD key 7-1 or +/FORWARD key 7-2.

The number of stitches can be set 4 to 20 stitches.

In the case the round bar is selected for the type of bartack, the number of overlapping stitches at the beginning and end of sewing can be set using Data No. 9 "Compensation of the number of stitches at the end of sewing."

Caution When the number of stitches is small, the sewing speed is automatically reduced.

7-31. Setting the number of overlapping stitches of round bar 2

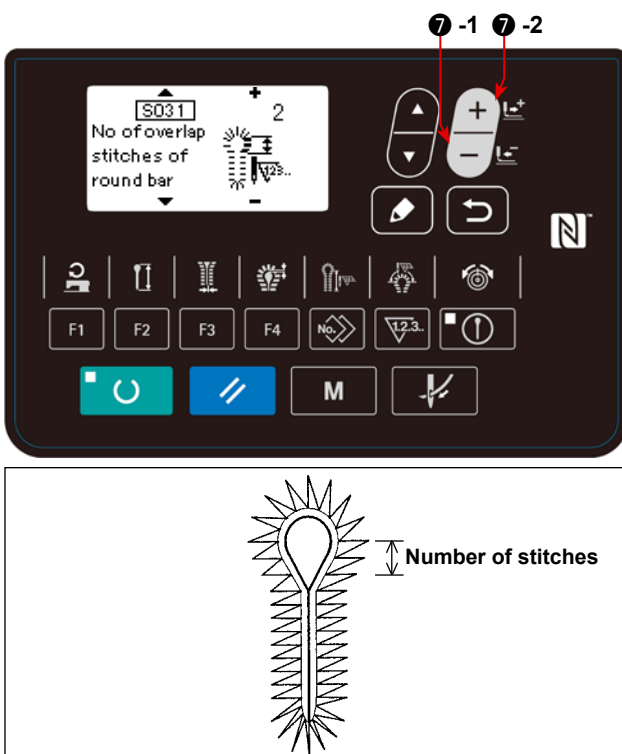

In this step of procedure, the number of overlapping stitches of the round bar 2 at the beginning and end of sewing is to be set.

Set the knife number by means of –/BACKWARD key 7-1 or +/FORWARD key 7-2.

The number of stitches can be set 1 to 10 stitches.

7-32. Setting the needle throwing width of the round bar

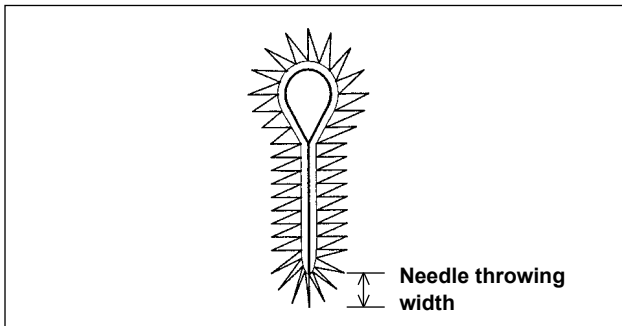
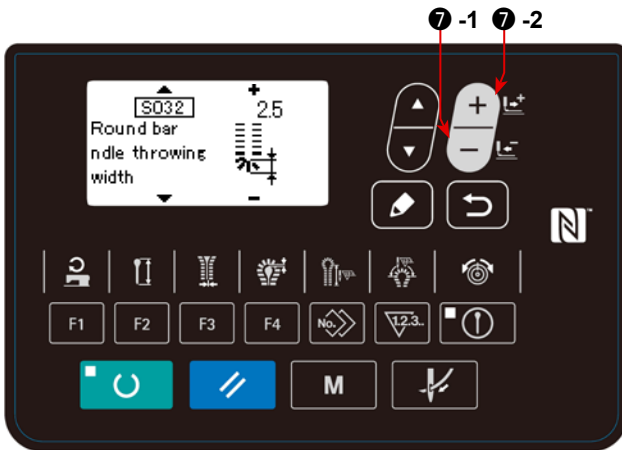

The needle throwing width of the round bar is set. Change the stitch width by operating the feed base along with the needle throwing operation.

Set the knife number by means of **-/BACKWARD** key **7-1** or **+ /FORWARD** key **7-2**.

The needle throwing width can be set in the range of 2.5 ± 1.0 mm in increments of 0.1 mm.

7-33. Setting the needle throwing width at the upper section of eyelet bar

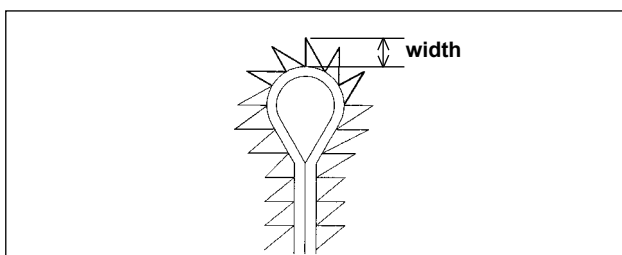
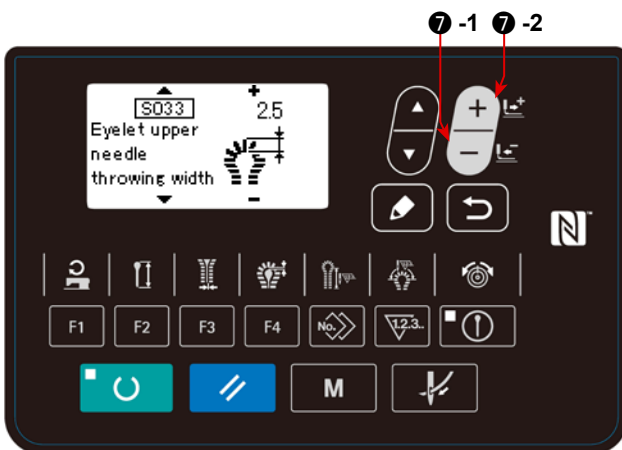

The needle throwing width at the upper section of eyelet bar is set.

Change the stitch width by operating the feed base along with the needle throwing operation.



Set the knife number by means of **-/BACKWARD** key **7-1** or **+ /FORWARD** key **7-2**.

The needle throwing width can be set in the range of 2.5 ± 1.0 mm in increments of 0.1 mm.

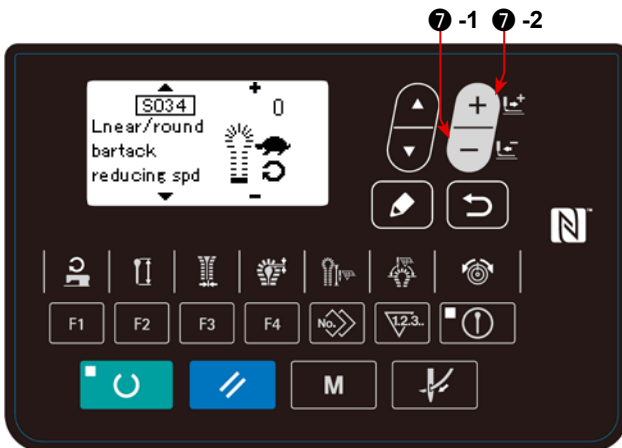
7-34. Setting the reduced sewing speed for straight/round bar



The reduced sewing speed is set, which is used as a target of speed reduction when you want to reduce the sewing speed for straight/round bar.



Set the knife number by means of –/BACKWARD key  **7-1** or +/FORWARD key  **7-2**.

The speed reduction can be set in increments of 100 sti/min within the range from –600 to 0 sti/min.

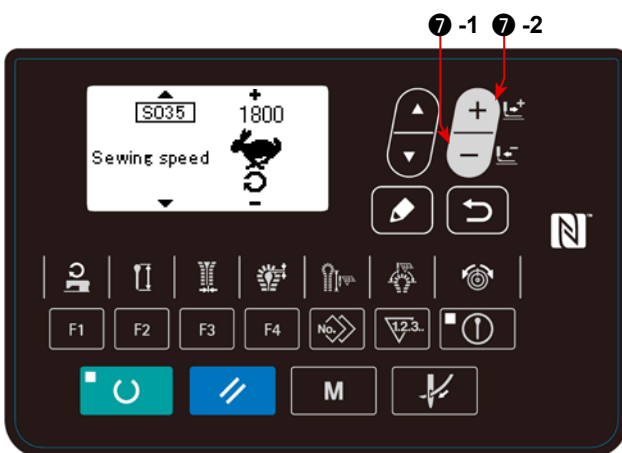
7-35. Setting the sewing speed



Set the sewing speed of the whole sewing.



Set the knife number by means of –/BACKWARD key  **7-1** or +/FORWARD key  **7-2**.

The sewing speed can be set 400 sti/min to 2,500 sti/min in the increments of 100 sti/min.

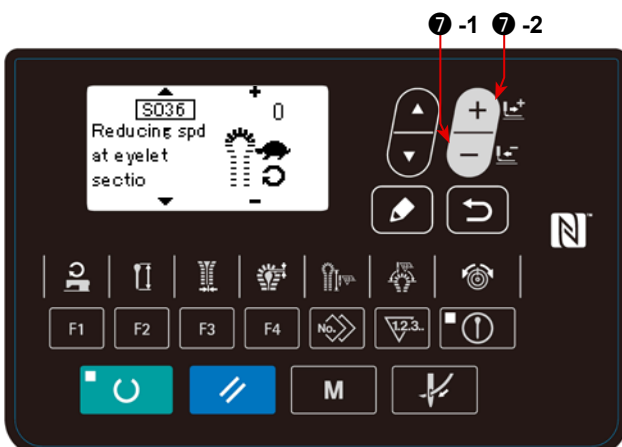
7-36. Setting the reduction speed of eyelet



Set the reduction speed when the sewing speed of eyelet section is desired to be reduced.

Set the knife number by means of –/BACKWARD key  **7-1** or +/FORWARD key  **7-2**.

The speed can be set –600 sti/min to 0 sti/min in the increments of 100 sti/min.

7-37. Setting the soft start

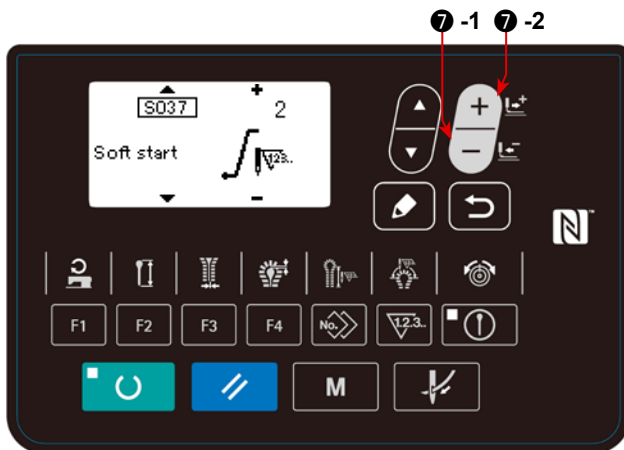

Sewing speed at the sewing start can be limited.

Set the knife number by means of –/BACKWARD key **7-1** or +/FORWARD key **7-2**.

The soft start can be set in the range from 0 (zero) to six revolutions.

* Two rotations of the inner needle and outer needle correspond to one stitch.



Sewing speed per rotation can be set with memory switches Nos. 02 to 07. Refer to "13. MEMORY SWITCH" p. 117 for the procedure.

All machines have been delivered with the speed set to 600 sti/min.

7-38. Setting the number of stitches at the beginning of sewing of thread tension

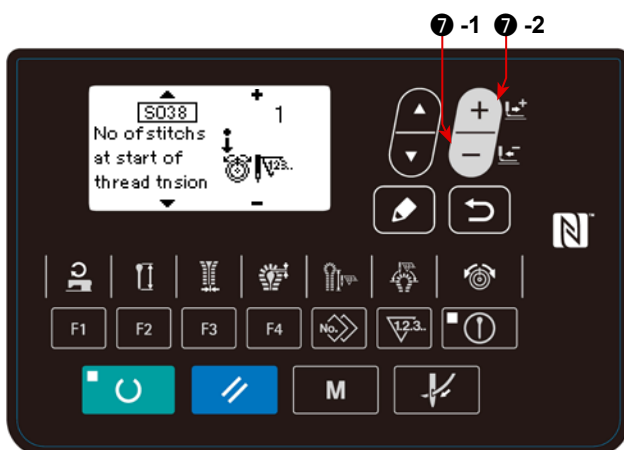

It is possible to set the number of stitches at the beginning of sewing at the time of setting the needle thread tension.

Set the knife number by means of –/BACKWARD key **7-1** or +/FORWARD key **7-2**.

The number of stitches can be set in the range from 0 (zero) to three stitches.

7-39. Setting the number of stitches at the end of sewing of thread tension

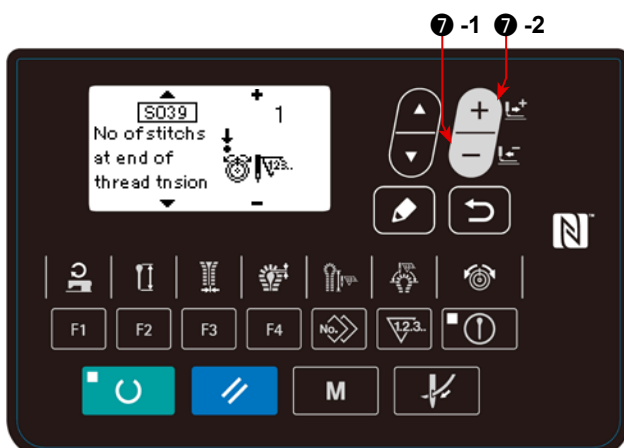

It is possible to set the number of stitches at the end of sewing at the time of setting the needle thread tension.



Set the knife number by means of –/BACKWARD key **7-1** or +/FORWARD key **7-2**.

The number of stitches can be set in the range from 0 (zero) to three stitches.

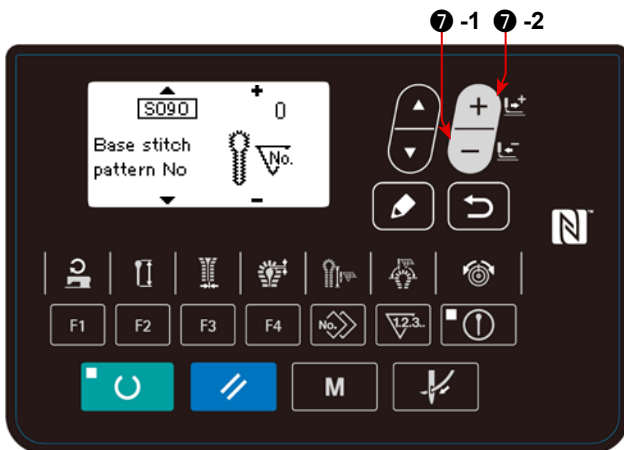
7-40. Setting the basting pattern number



In the case "with / without basting" selection is set to "with basting", the basting pattern number should be set.

Set the knife number by means of –/BACKWARD key  **7-1** or +/FORWARD key  **7-2**.



0 : Without basting

1 to 99 : Basting pattern number

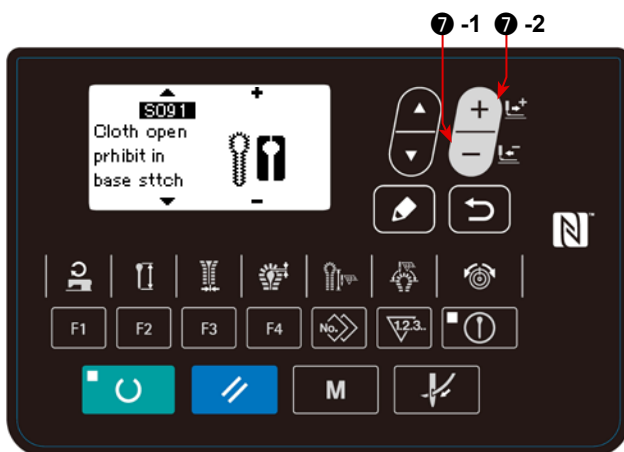
7-41. Setting the prohibition of opening during basting



Set the operation of the cloth opener during basting.

Set the knife number by means of –/BACKWARD key  **7-1** or +/FORWARD key  **7-2**.

0 : Cloth opener operates during basting

1 : Cloth opener operation is prohibited during basting

7-42. Setting the number of stitches for sewing a radial stitch eyelet

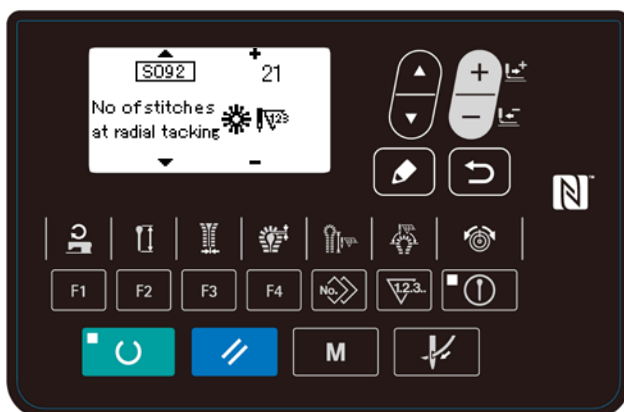

Set the number of stitches for sewing a radial stitch eyelet (for 360°).

7-43. Setting the overlap stitching angle for the radial stitch eyelet

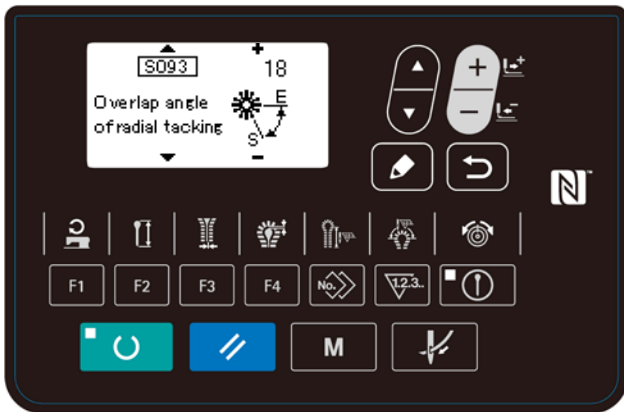

Set the overlap stitching angle at the beginning of radial stitch eyelet sewing.

7-44. Setting the radial stitch eyelet diameter

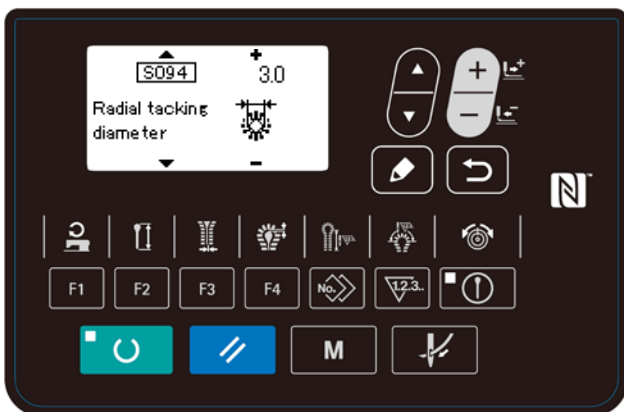

Set the sewing hole diameter when sewing radial stitch eyelets.

8. ADJUSTMENT OF EACH PART

8-1. Adjusting the pressure of the cloth trimming knife



WARNING :

1. Turn OFF the power before starting the work so as to prevent accidents caused by abrupt start of the sewing machine.
2. To avoid unexpected personal injuries, keep away from the looper thread trimming knife and cloth trimming knife during the adjustment procedure.



- * The pressure of the cloth trimming knife can be changed.
- * Normally, the cloth trimming knife is able to cut the material with its standard pressure. However, the pressure may be inadequate for some sewing materials and sewing conditions. In this case, the air pressure can be set to 0.4 MPa at the maximum. Adjust the pressure to any value below the maximum pressure.
- * Air pressure has to be changed after the hammer surface and condition and mating surface of the knife blades have been properly adjusted and carefully checked.
- * The pressure value should be gradually increased from the lower value while checking whether the knife cuts the material with each pressure value.

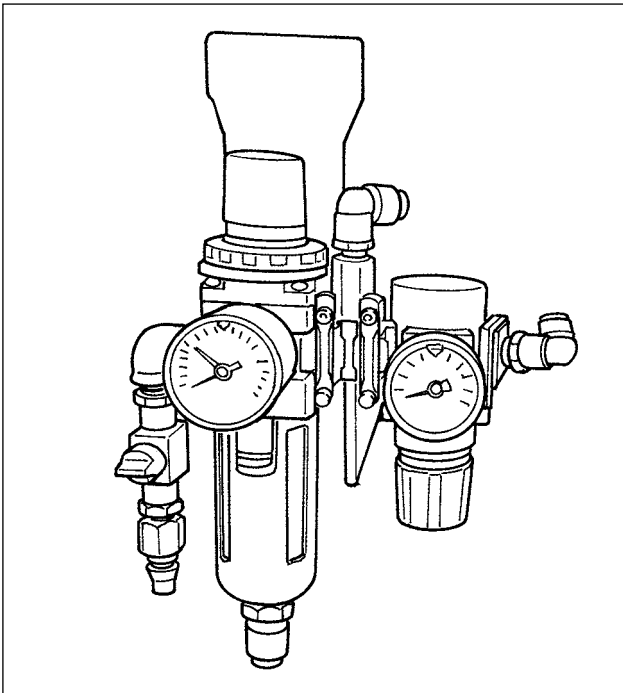

■ Adjusting the knife pressure

The pressure of the cloth trimming knife is adjusted by the air pressure of the regulator for adjusting the cloth cutting knife pressure.

The standard pressure has been factory-set at 0.35 MPa.



Set the knife pressure as low as possible in order to maintain durability of the knife blades and the hammer. Excessively high pressure can cause a chipped or nicked edge of the knife blade. Adjust the pressure to any value below the maximum pressure (0.4 MPa).

8-2. Adjusting the stitch bite width



WARNING :

Turn OFF the power before starting the work so as to prevent accidents caused by abrupt start of the sewing machine.

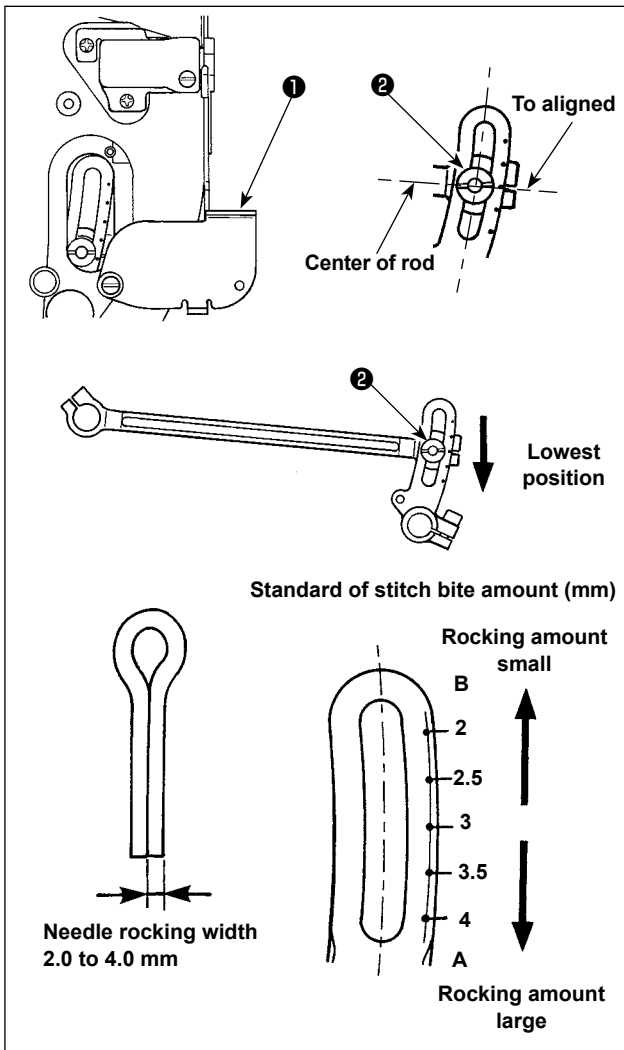

- 1) Open needle rocking adjustment cover ❶.
- 2) Turn the handwheel to bring the needle bar to its lowest position.
- 3) Loosen fulcrum shaft ❷ of rocking link B.
 - Moving the rocking link B in the direction **A** increases the stitch bite width.
 - Moving the rocking link B in the direction **B** decreases the stitch bite width.
- 4) When the stitch bite width is determined, fix fulcrum shaft ❷ of rocking link B and close the needle rocking adjustment cover.
- 5) After adjusting the stitch bite width in the aforementioned steps, check the respective items of "[10-2. Timing between the needle and the looper](#)" p. 95, "[10-5. Clearance between the needle and the looper](#)" p. 100 and "[10-7. Clearance between the spreader and looper and the opening timing of the spreader](#)" p. 101.



The engraved marker dot is a standard. Make sure of the amount by putting the needle tip marks on a sheet of paper or the like for the precise measurement.

8-3. Adjusting the presser



WARNING :

Turn OFF the power before starting the work so as to prevent accidents caused by abrupt start of the sewing machine.

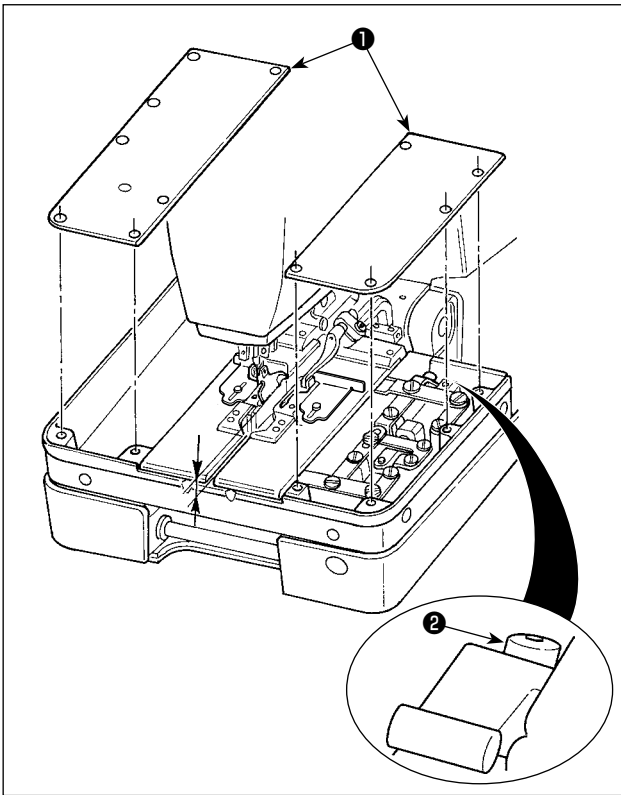

■ Adjusting the height of the presser

- 1) Remove auxiliary presser plate cover ❶.
- 2) Loosen screw ❷ and adjust the height of the presser.

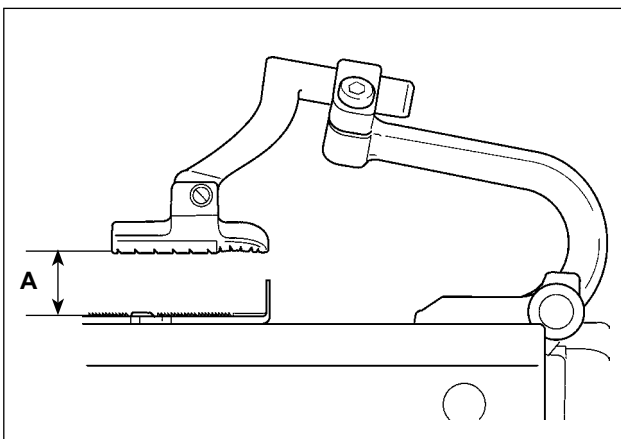

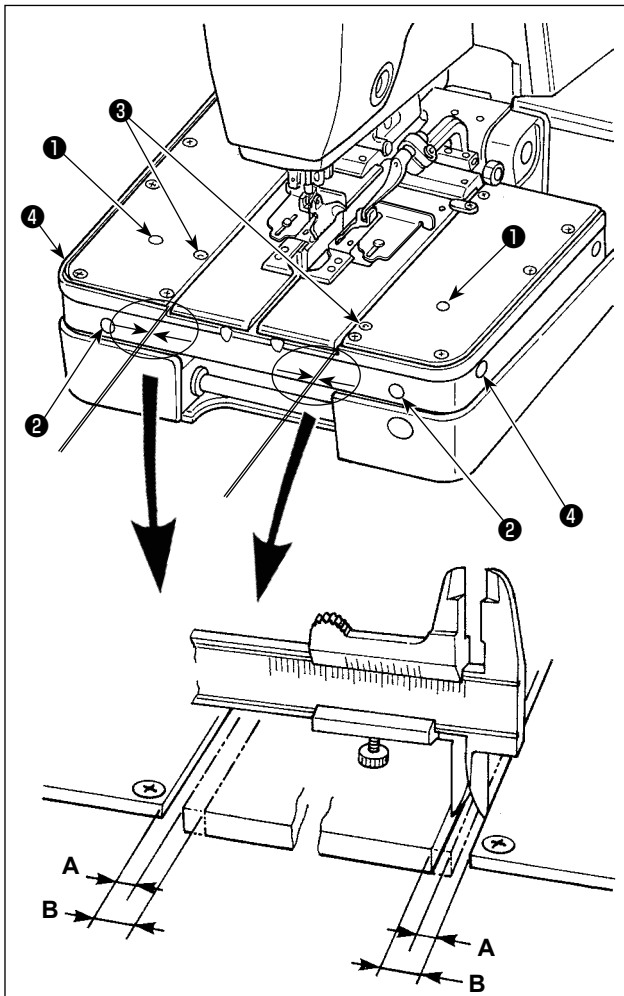

The standard presser foot height **A** is 13 mm.

8-4. Adjusting the presser opening amount



How to check the cloth opening amount

- 1) Turn the power ON. Press the READY key  to light up the sewing LED.
- 2) Press the knife ON/OFF key  to turn off the LED to disable the cloth trimming knife.
- 3) Press the presser switch and press the +/FORWARD key . Then, the cloth opener is opened and the feed base moves to the sewing start position and stops there.



The standard adjustment value when the cloth opener is opened is "A = 2.3 mm".

- 4) Press the RESET key . Then, the presser foot goes up and the cloth opener is closed to return to its origin.



1. The standard adjustment value of the cloth opening amount when the cloth opener is closed is "B = 3 mm". As a result, the standard cloth opening amount is obtained by the formula shown below:
 $B - A = 0.7 \text{ mm}$

2. In the case the cut-before knife is used for sewing, in particular, the cloth opening amount should be adjusted according to the material to be sewn.

Adjustment procedure

[Adjustment of dimension A]

Insert a screwdriver from ① to loosen the screw. Dimension A can be adjusted by inserting the screwdriver into hole ② and turning the screw placed at the bottom of the hole. Turning the screwdriver clockwise will decrease dimension A, or counterclockwise will increase it.

[Adjustment of dimension B]

Insert a screwdriver from ③ to loosen the screw. Dimension B can be adjusted by inserting the screwdriver into hole ④ and turning the screw placed at the bottom of the hole.

Turning the screwdriver clockwise will decrease dimension B, or counterclockwise will increase it.



WARNING :

The confirmation of cloth open amount can be performed by actually cutting cloth in the manual mode. However, the cloth cutting knife works. So, be careful.



1. In the following cases, set the adjustment value A of the cloth opening amount when the cloth opener is opened to the standard value or less. At this time, take care to prevent interference between the related parts.
 - * In the case the straight bartacking length is set to more than 6 mm;
 - * In the case the throat plate is lifted above the standard position and the straight bartacking length is set to longer than 5.5 mm;
 - * In the case the total of the cloth cutting space, correction value of cutting space, left, and correction value of needle throwing width exceeds 1.1 mm;
 - * In the case the throat plate is lifted above the standard position and the total of the cloth cutting space, correction value of cutting space, left, and correction value of needle throwing width exceeds 0.9 mm.
2. When sewing is performed using the cut-before knife, the standard cloth opening amount may be insufficient. Adjust the cloth opening amount according to the material to be sewn so that it is opened sufficiently.

8-5. Adjusting the needle thread drawing amount



WARNING :

Turn OFF the power before starting the work so as to prevent accidents caused by abrupt start of the sewing machine.

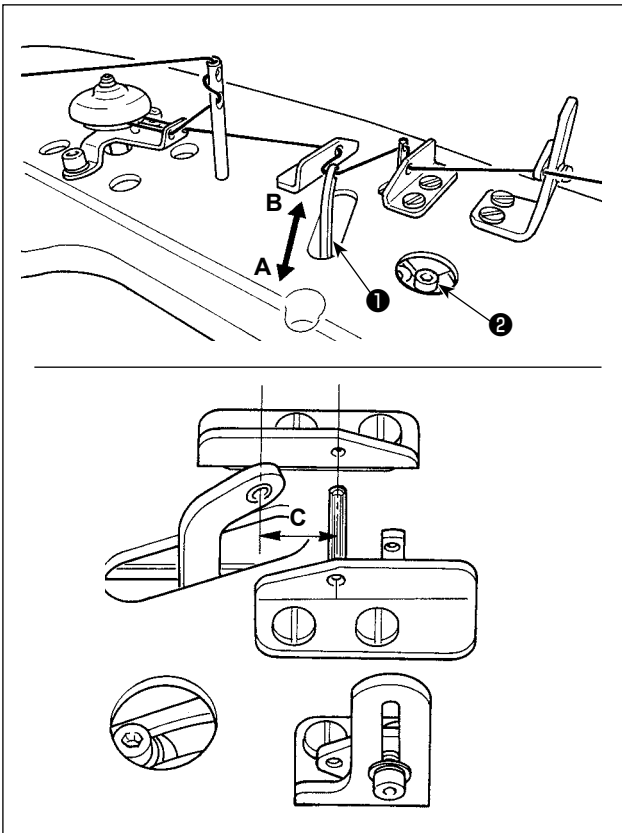

■ Adjusting the drawing amount of the needle thread at the sewing start

Carry out the adjustment with the air supplied.

Loosen screw ② and move thread drawing arm ① in direction A or B to adjust the drawing amount of the needle thread.

For the standard adjustment value, dimension C is 18 mm (or 23 mm if the machine is provided with the needle thread clamp unit).

8-6. Adjusting the thread take-up thread guide



WARNING :

Turn OFF the power before starting the work so as to prevent accidents caused by abrupt start of the sewing machine.

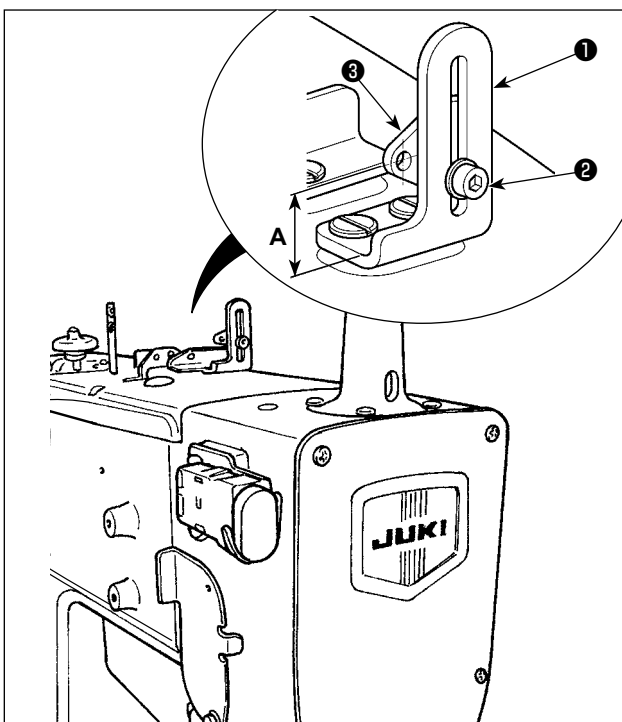

Loosen screw ②. Move thread take-up thread guide ③ mounted on thread take-up thread guide mounting base ① up and down to adjust its installing position.

For the standard adjustment, dimension A is 15.5 mm.

8-7. Adjusting the remaining amount of the gimp

WARNING :



1. Turn OFF the power before starting the work so as to prevent accidents caused by abrupt start of the sewing machine.
2. To avoid unexpected personal injuries, keep away from the looper thread trimming knife and cloth trimming knife during the adjustment procedure

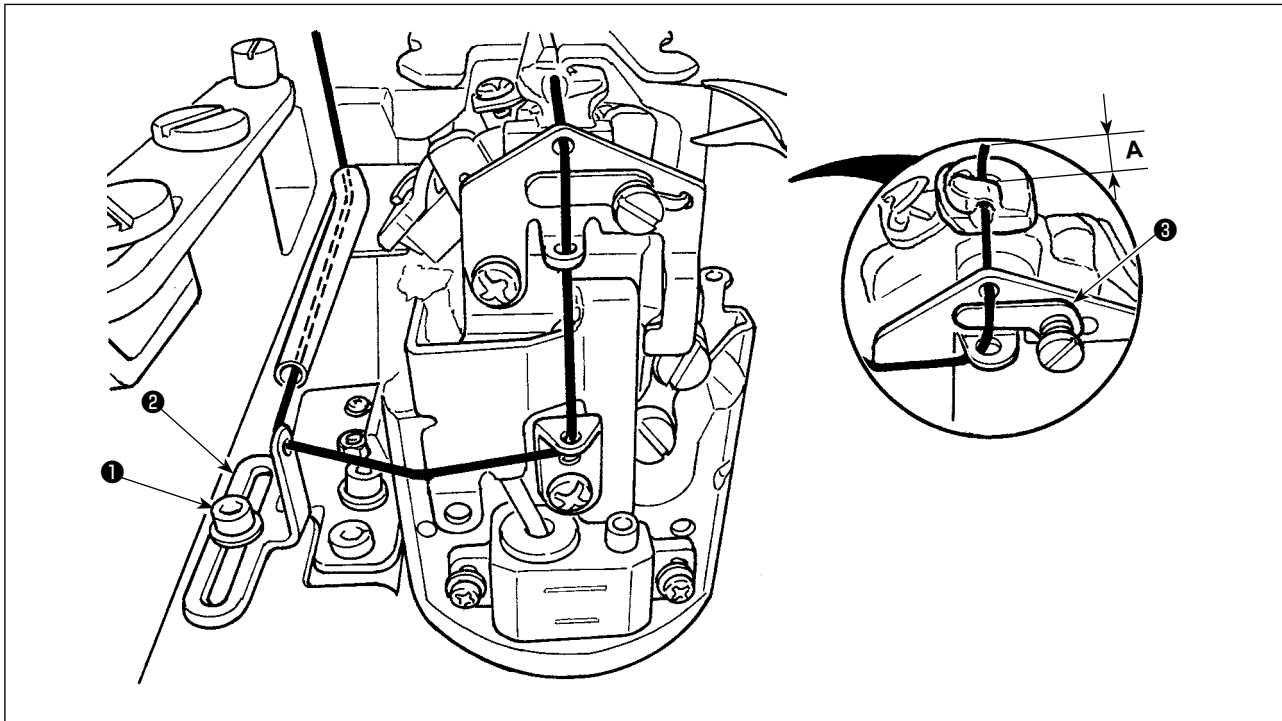

- 1) Loosen setscrew ❶. Move gimp thread guide ❷ to and fro to adjust remaining amount A of the gimp at the end of sewing.
- 2) Adjust the remaining amount of the gimp, while actually sew the remainder of the material to check the adjustment result.



There is a case where the remaining amount of gimp is not stable when sewing thread or the like is used for the gimp. In this case, insert the gimp in the gimp presser plate ❸.

8-8. Adjusting the gimp thread tension

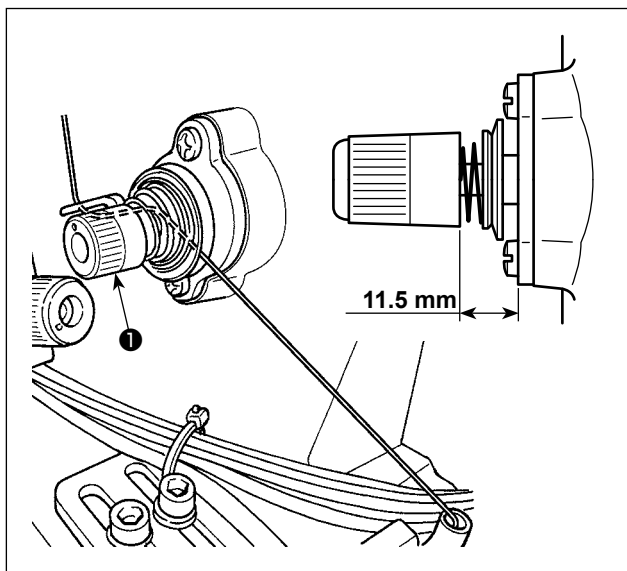

Loosen nut ❶ and carry out adjustment.

The standard adjustment value is 11.5 mm.

When double nut ❶ is tightened, the gimp tension becomes higher and the length of remaining thread at the time of looper thread trimming becomes shorter.

1. For a light-weight material or elastic material, lower the gimp tension than the standard adjustment.



2. When gimp thread tension is excessively low or high, there is a case where the length of remaining gimp becomes unstable. The standard adjustment value is 11.5 mm.

8-9. Needle thread clamp unit (optional)



WARNING :

Turn OFF the power before starting the work so as to prevent accidents caused by abrupt start of the sewing machine.

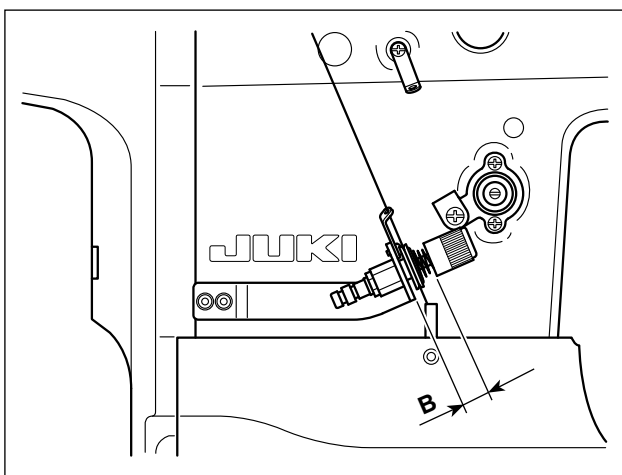
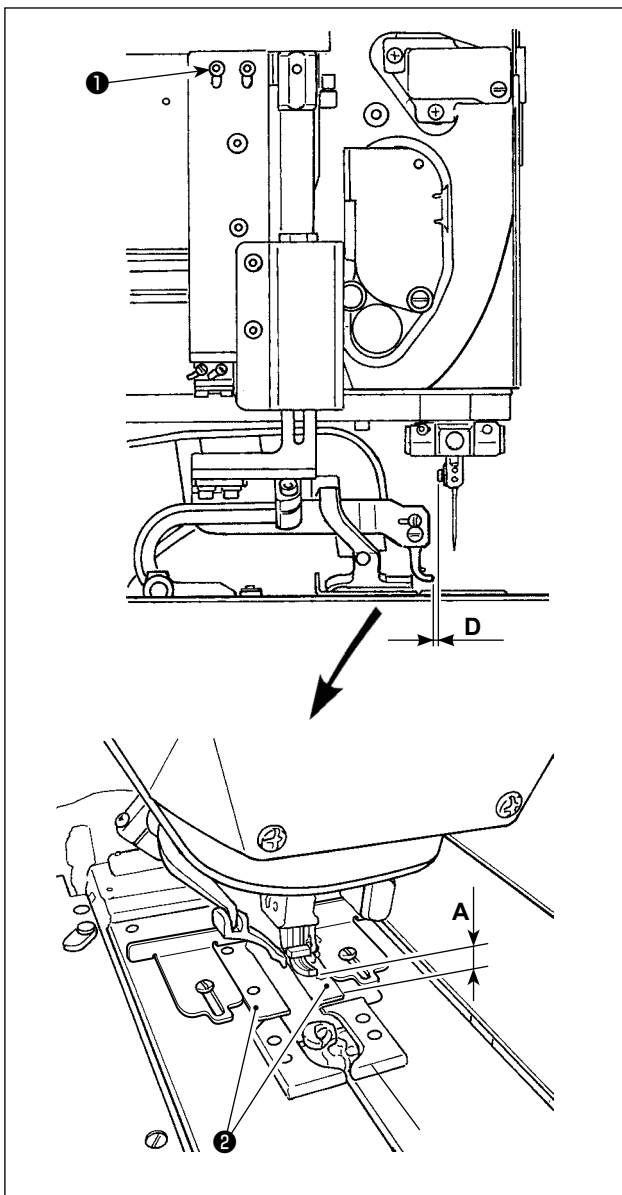

When the clamp of the needle thread clamp unit is in the lower position, standard height **A** of the underside of the clamp from the top surface of presser support plate **2** is 6 mm.

When using a heavy-weight material or the like, the clamp may come in contact with the material. In this case, loosen screw **1** and adjust the clearance between the underside of the clamp in its lower position and the material to 2 to 3 mm.



When you have adjusted the height, check to make sure that the clearance **D** provided between the top end of the clamp and the screw of the needle bar thread guide is 1.5 to 2 mm.

In the case the sewing machine is installed with the needle thread clamp unit, the position of the needle thread drawing arm will be different from its position without the unit.

Dimension **C** described in "[8-5. Adjusting the needle thread drawing amount](#)" p. 79 is 23 mm.

(Standard dimension **C** is 18 mm for the sewing machine which is not provided with the needle thread clamp unit.)

The length of the needle thread remaining on the needle can be adjusted by setting it on the operation panel. It is adjusted by setting the needle thread tension.

Referring to "[9-1. Operating procedure of thread tension compensation of each section](#)" p. 83 for the setting procedure, call Compensation Position No. 54 on the display.

When the set value (initial value: 0) is increased to a positive value, the more the number is increased, the shorter the remaining thread will become.

When the set value is decreased to a negative value, on the contrary, the length of thread remaining on the needle is increased.

The setting can be separately done on a pattern-by-pattern basis.

The thread tension controller for the needle thread clamp unit works to prevent the thread from loosening at the end of sewing.

Turn the tension regulating knob to adjust distance **B** to 15 to 16 mm.

8-10. Adjusting the brightness of the hand lamp

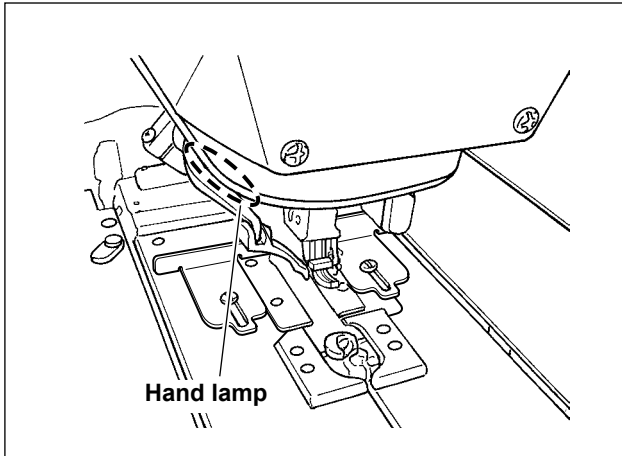

The brightness of the hand lamp can be adjusted on the operation panel.

- 1) Select the memory switch operation mode.
Refer to **"13. MEMORY SWITCH" p. 117** for how to operate the memory switch operation mode.
- 2) Display MEMORY switch U030 by pressing ▼ key 6-1 or ▲ key 6-2 to display memory switch No. 30.
- 3) Change the set value by pressing - / BACKWARD key 7-1 or +/FORWARD key 7-2.
The brightness can be set to one of 20 steps from 0 (total extinction) to 100 (maximum). The brightness has been factory-set to 100 (maximum) at the time of shipment.
After the completion of the adjustment of brightness to an appropriate value, press READY key 2 to confirm the setting. Then, exit the memory switch operation mode.

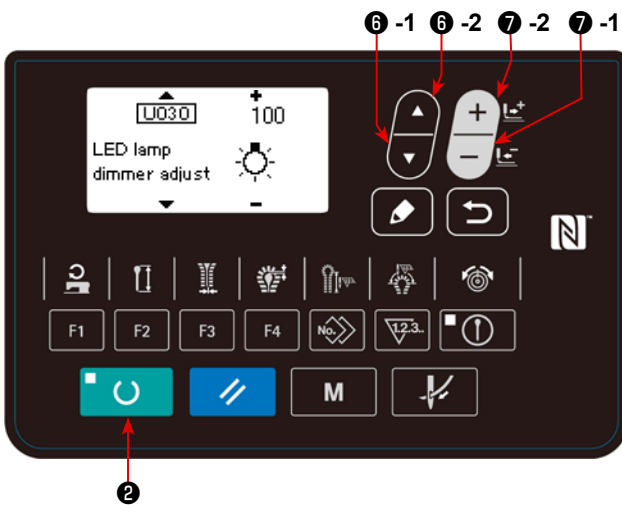

9. HOW TO USE THE VARIOUS FUNCTIONS



Refer to "13. MEMORY SWITCH" p. 117 for how to set the memory switches described below.

9-1. Operating procedure of thread tension compensation of each section

Thread tension of each section of the sewing shape can be individually changed.

The thread tension applied to each section of a buttonhole is the value obtained by adding the respective compensated values to the needle thread tension set value (No. 40).

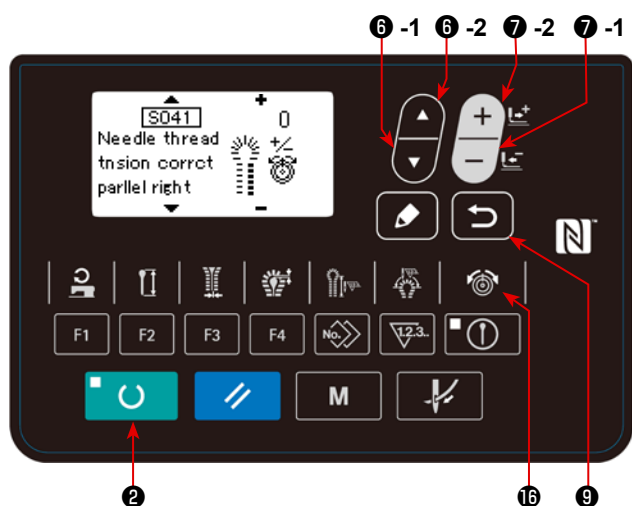

- 1) Press THREAD TENSION key 16 to display the thread tension value.
- 2) Select the correction position No. for each thread tension by pressing ▼ key 6-1 or ▲ key 6-2. (Refer to Appendixes 1 and 2 for the compensation position numbers.)
- 3) After the selection of the compensation position number, press -/BACKWARD key 7-1 or +/FORWARD key 7-2 to input a thread tension compensation value.

- 4) The set value is stored in memory by pressing READY key 2 or starting sewing with the START switch.
- 5) The display goes back to the normal display by pressing RETURN key 9 while the thread tension LED is ON.



When you change the pattern number or turn the power OFF without carrying out the operation described in 4), the set value will not be stored in memory.



For the compensation position No., refer to tables 1 and 2 and Figs. 1 and 4.

Table1

[Setting of needle thread tension]

Compensation position No.	Setting item	Description
40	Needle thread tension	Needle thread tension value
41	Compensation of needle thread tension of right parallel section	Compensation value of needle thread tension of right side of parallel section
42	Compensation of needle thread tension of left parallel section	Compensation value of needle thread tension of left side of parallel section
43	Compensation of needle thread tension of top eyelet	Compensation value of thread tension of top eyelet
44	Compensation of needle thread tension of right bottom of eyelet	Compensation value of needle thread tension of right bottom of eyelet
45	Compensation of needle thread tension of left bottom of eyelet	Compensation value of needle thread tension of left bottom of eyelet
46	Compensation of needle thread tension at bartack, right	Refer to Table 2 "Correspondence of needle thread tension to each type of bartack"
47	Compensation of needle thread tension at bartack, left	Refer to Table 2 "Correspondence of needle thread tension to each type of bartack"
48	Compensation of needle thread tension at bartack, right 2	Refer to Table 2 "Correspondence of needle thread tension to each type of bartack"
49	Compensation of needle thread tension at bartack, left 2	Refer to Table 2 "Correspondence of needle thread tension to each type of bartack"

Compensation position No.	Setting item	Description
50	Compensation of needle thread tension of sewing start	Compensation value of needle thread tension of sewing start
51	Compensation of needle thread tension of sewing end	Compensation value of needle thread tension of sewing end
52	Compensation of needle thread tension at the time of thread trimming	Compensation value of needle thread tension at the time of thread trimming of sewing machine * 1
53	Compensation of needle thread tension at the time of stop	Compensation value of needle thread tension at the time of stop of sewing machine * 2
54	(When the needle thread clamp unit is selected as an option) Compensation of needle thread tension for drawing needle thread clamped by the needle thread clamp unit.	Compensation value of the needle thread tension for drawing the needle thread after the needle thread clamp unit has clamped the needle thread * 3

* 1 : Compensation value as against memory switch No. 8 (needle thread tension at the time of thread trimming)
(When the needle thread clamp unit is selected as an option)

Compensation value for memory switch No. 33 (needle thread tension for trimming clamped needle thread)

* 2 : Compensation value as against memory switch No. 10 (needle thread tension at the time of stop)

* 3 : Compensation value for memory switch No. 34 (needle thread tension for drawing clamped needle thread)

[Correspondence of needle thread tension to each type of bartack]

Table2

Type of bartack		Taper bar	Straight bar	Round bar	Round bar 2
Compensating position					
46	Compensation of needle thread tension at bartack, right	Right side of parallel section	Whole	At the beginning of sewing	Overlapping section at the beginning of sewing
47	Compensation of needle thread tension at bartack, left	Left side of parallel section	-	At the end of sewing	Whole
48	Compensation of needle thread tension at bartack, right 2	Right side of linear slant section	Parallel section → Straight bar	-	-
49	Compensation of needle thread tension at bartack, left 2	Left side of linear slant section	-	-	-



1. The actual thread tension varies in accordance with the kind or thickness of thread used even when the set value of thread tension is the same. Especially, in case of thread of which the surface is hard to slide, the thread tension becomes higher, and even when the set value is as low as 60 to 70, the loop becomes smaller. As a result, stitch skipping may be caused. When using plural threads, it is recommended to make a sewing pattern to which set values of thread tension suitable for the respective threads have been inputted.

2. When the needle thread tension (No. 52) at the end of sewing is set to a high value, stitch skipping at the end of sewing or failure of needle thread take-up may occur.

[Compensation position of taper bar]

Fig. 1

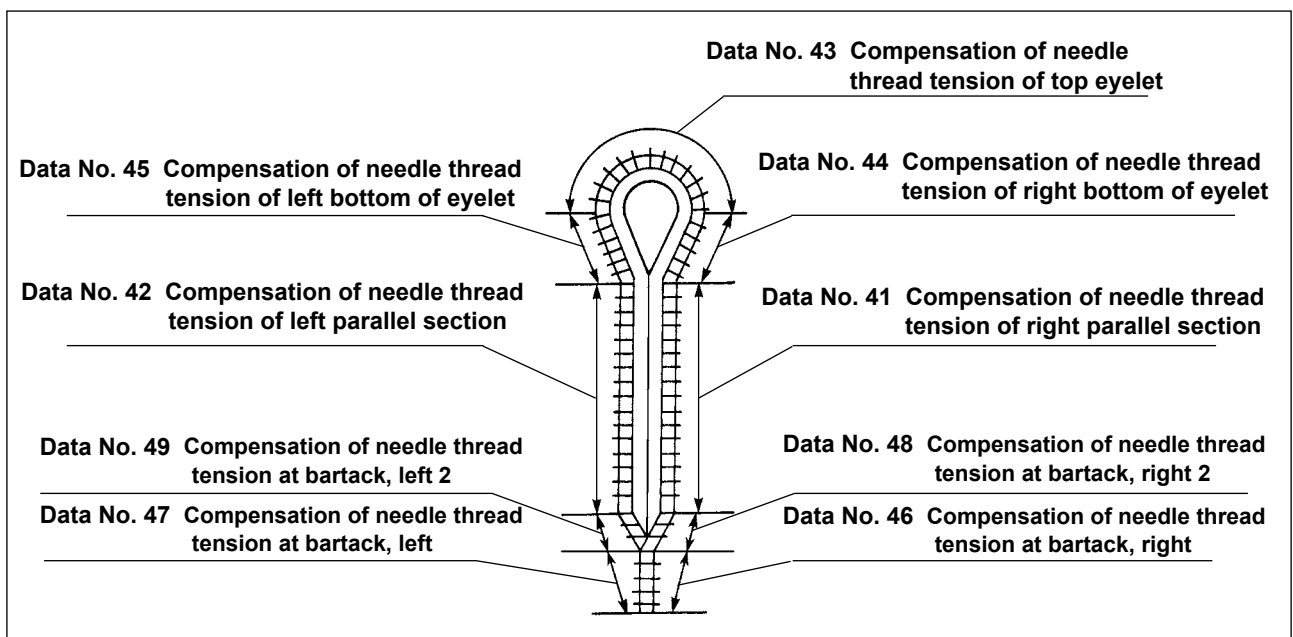

[Compensation position of straight bar]

Fig. 2

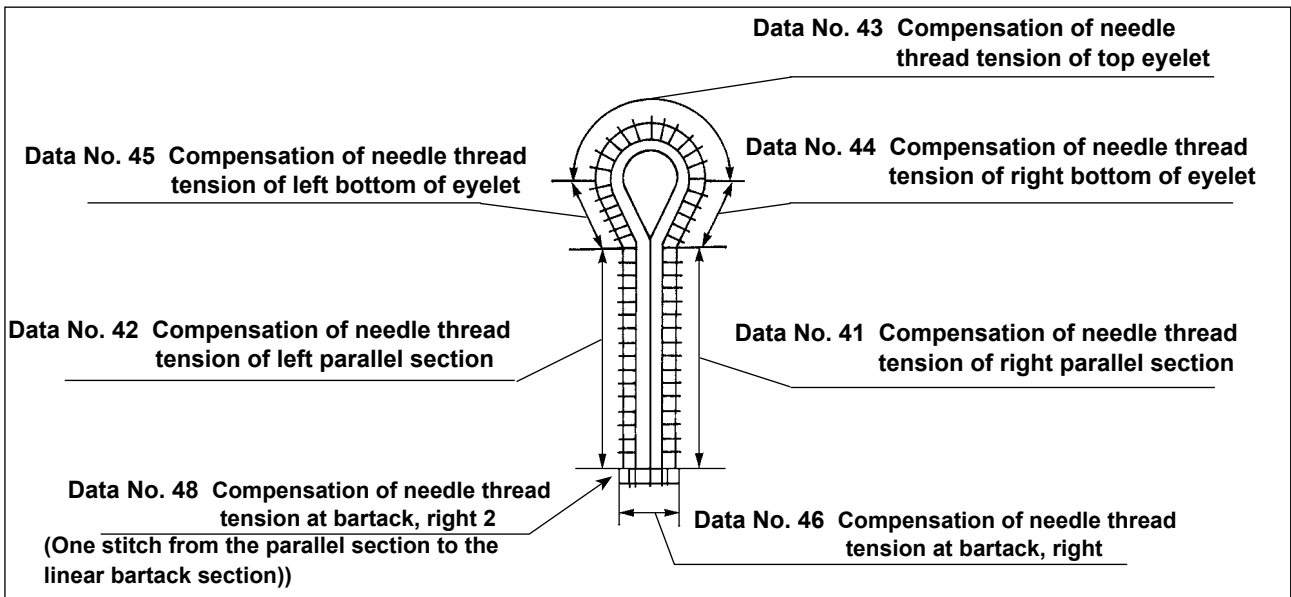

[Compensation position of round bar]

Fig. 3

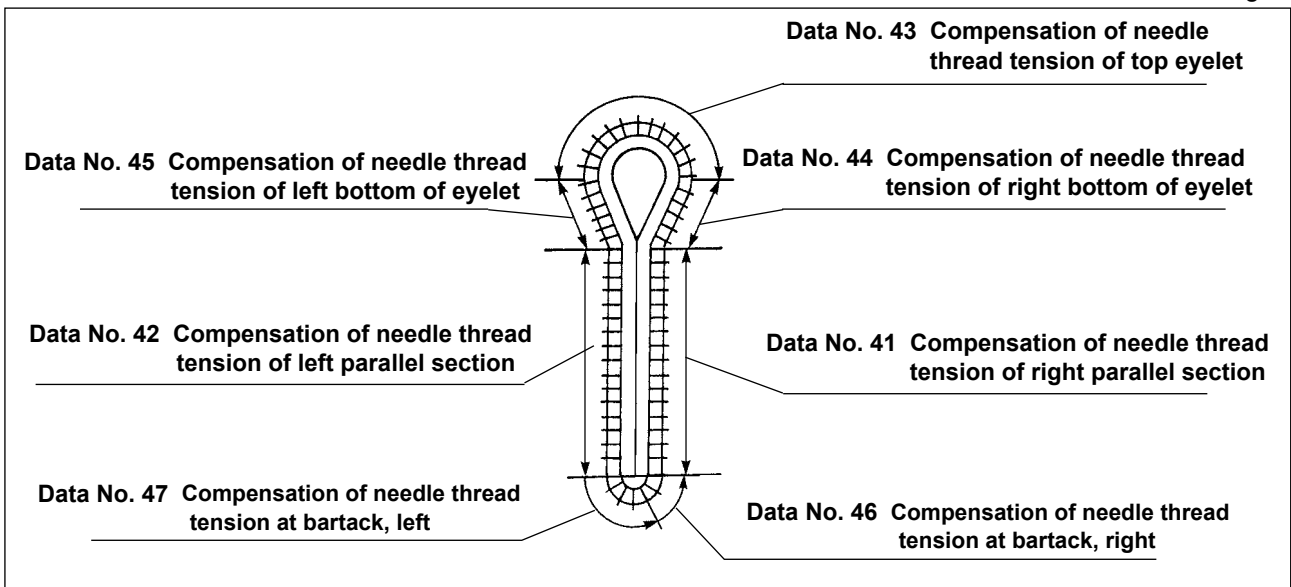

[Compensation position of round bar 2]

Fig. 4

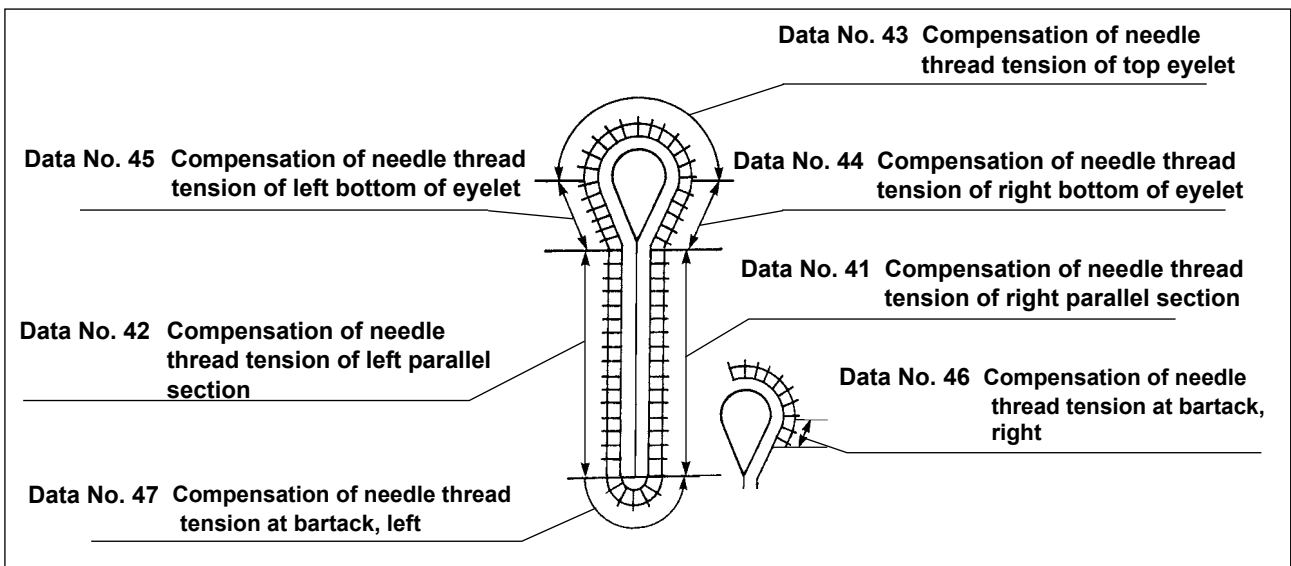

9-2. Changing the setting position of cloth

The setting position of the material can be changed to the front side or the sewing start position in the case of cut-after knife/without knife.

- (1) To set the material setting position at the front side for every type of knife setting, i.e., cut-before knife/cut-after knife/without knife.

1) Set memory switch U012 to "".

2) Set the travel amount to this side using Memory switch U023. (Factory-set to 22 mm as standard at the time of shipment)

- (2) To set the material setting position at the origin in the case of the cut-before knife, and at the sewing start position in the case of the cut-after knife/without knife.

1) Set memory switch U012 to "".

- (3) To set the material setting position at the front side in the case of the cut-before knife, and at the sewing start position in the case of the cut-after knife/without knife.

1) Set memory switch U012 to "".

2) Set the travel amount to this side using Memory switch U0 23. (Factory-set to 22 mm as standard at the time of shipment)

9-3. Changing over the mode of the start switch

The presser comes down by the operation of the start switch only, and the sewing is continually performed.

Set memory switch U015 to "".





It is also possible to perform the normal use by lowering the presser with the presser switch and performing sewing with the start switch. However, the presser LED of the hand switch is always put in the state of flashing on and off.

9-4. Changing over the presser movement

It is possible that the presser returns to the set position while it is held lowered after completion of sewing.

(The presser returns to the set position while it is raised after completion of sewing in the standard state of delivery.)

- 1) Set Memory switch U020 to "" or "".

① The presser foot goes up after the feed base returns to the material setting position when Memory switch U020 is set to "".

② The presser foot is lifted by means of the Presser foot switch after the feed base returns to the material setting position when Memory switch U020 is set to "".

- 2) The presser foot is kept lowered also when the feed base is brought back to the material setting position by means of the Reset key  in such a case sewing is stopped before the end of sewing is reached by means of the Temporary stop switch.

9-5. Changing over to the mode of the stop before cloth cut

The sewing can be temporarily stopped before performing the cloth cutting operation at the time of the pattern sewing of cut-after knife data.

- 1) Set memory switch U021 to "". The sewing machine once stops after sewing and cloth cutting operation is performed by again pressing the start switch.

It is also possible to return the sewing machine to the cloth set position without performing cloth cutting operation by pressing RESET key .

9-6. How to copy / delete the sewing pattern

Data of pattern No. which has been already registered can be copied to pattern No. which has not been used. Overwriting copy of the pattern is prohibited. When you desire to overwrite, perform it after erasing the pattern once.

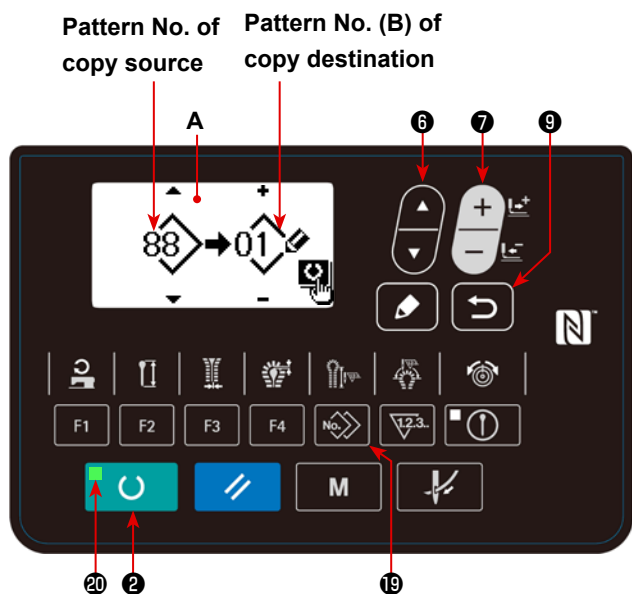

1) Set the mode to input mode

Under the input mode where SET READY LED ⑳ goes out, copy is enabled.

If the current mode is the sewing mode, press READY key  ② to change over the mode to the input mode.

2) Select pattern No. of copy source



Press ITEM SELECT key  ⑥ to select the source pattern No.

When creating pattern data quite newly. it is convenient to copy the initial value pattern.

3) Call copy screen

Press COPY key  ⑱, and copy screen A is displayed.

4) Select pattern No. of copy destination

Pattern No. B which is not used is displayed. Press DATA CHANGE key  ⑦ to select a number to be used for copying. When you desire to erase the pattern, select the garbage can .

5) Start copying

When READY key  ② is pressed, the copy starts. Then, the screen returns to the input screen on which the pattern No. which is created by copying is selected.

When RETURN key  ⑨ is pressed, the screen returns to the previous screen without performing copying.

9-7. How to adjust the contrast

The contrast of the display on the panel can be adjusted in five steps.

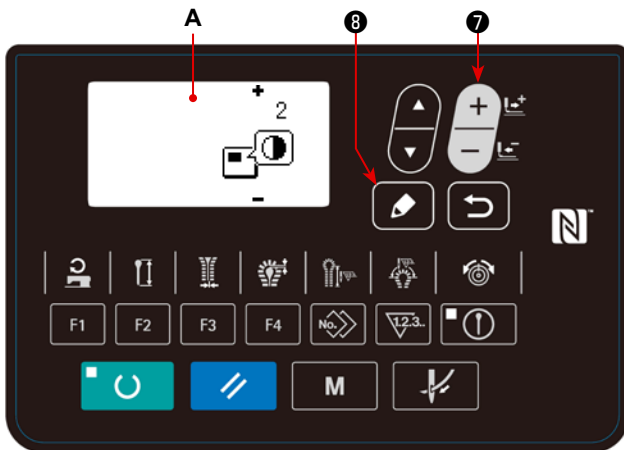

1) Calling the contrast adjustment screen

Select the contrast adjustment from the menu on the mode screen and press EDIT key  ⑧. Then, the contrast adjustment screen **A** is displayed.

2) Adjusting the contrast

The contrast can be adjusted in five steps from 0 (brightest) to 4 (darkest) by pressing DATA

CHANGE key  ⑦.

9-8. How to set the key lock

Operation of the data change key can be disabled by setting the key lock. Refer to the Engineer's Manual for how to invoke the key lock setting function and how to set the key lock.

9-9. Using parameter register key

Register parameters which are frequently used with parameter register key **F1** **F2** **F3** **F4** and use them.

Parameters which have been registered can be selected by pressing only the parameter register key **F1** **F2** **F3** **F4** under the input mode.

(1) Method of register

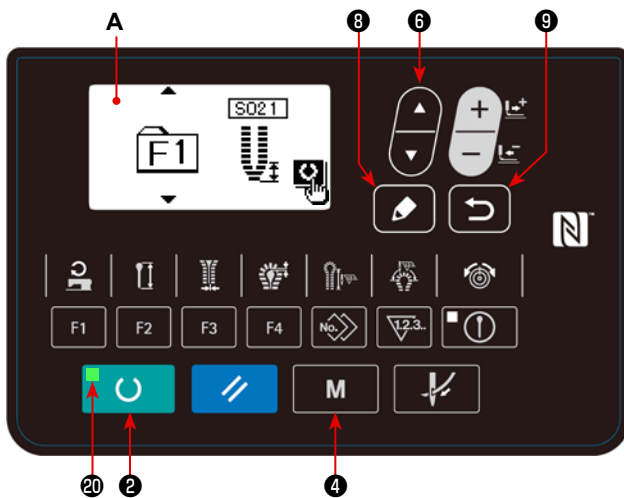

1) Set the mode to the input mode

Under the input mode where SET READY LED ⑩ goes out, parameter registration is enabled.

If the current mode is the sewing mode, press READY key **⏻** ② to change over the mode to the input mode.

2) Call parameter register screen

Press MODE key **M** ④ to display the mode screen. Select the parameter key registration on this screen. Then, the parameter registration screen **A** is displayed.

When you press EDIT key **✎** ⑧ on the screen, the parameter registration key setting screen is displayed. The parameter registration key **F1** **F2** **F3** **F4** setting screen can also be displayed by keeping the parameter registration key you want to edit held pressed.

3) Select parameter

Item **B** which can be registered to the key is displayed. Press ITEM SELECT key **⬆** ⑥ to select the item to be registered.

Items which can be registered are sewing data, parameters of memory switches (level 1) and pattern Nos.

In addition, when trash can **🗑** is selected, register can be released.

4) Start register

When READY key **⏻** ② is pressed, registration starts, and the screen returns to the mode screen.

When RETURN key **↩** ⑨ is pressed, the screen returns to the previous screen without performing registration.

(2) Register status at the time of your purchase

Register key	Registered parameter
F1	S021 Length of taper bar
F2	U012 Set position selection
F3	S020 Type of bartack
F4	Operation mode

9-10. Communication

This sewing machine is capable of inputting/outputting data by means of an USB thumb drive.

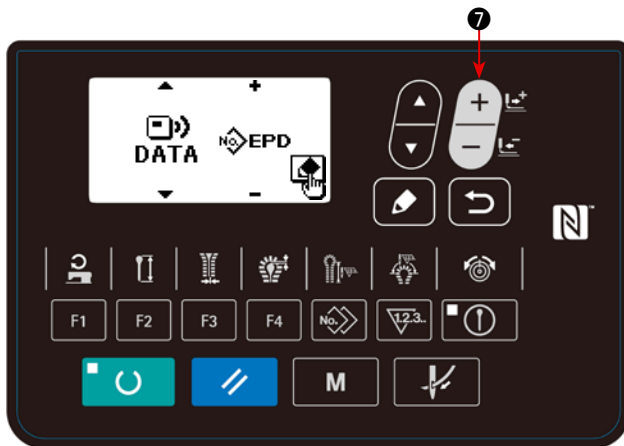

1) Entering the communication mode

Referring to the mode screen in "9-6. How to copy / delete the sewing pattern" p. 87, select the communication mode.

2) Selecting the type of communication

Press DATA CHANGE key  7 to select the type of communication.

Name of data		Extension	Description of data
Parameter data		MEB00 XXX . EPD	Unique MEB sewing data form such as stitch shape, cloth trimming length and overedging width created with the sewing machine.

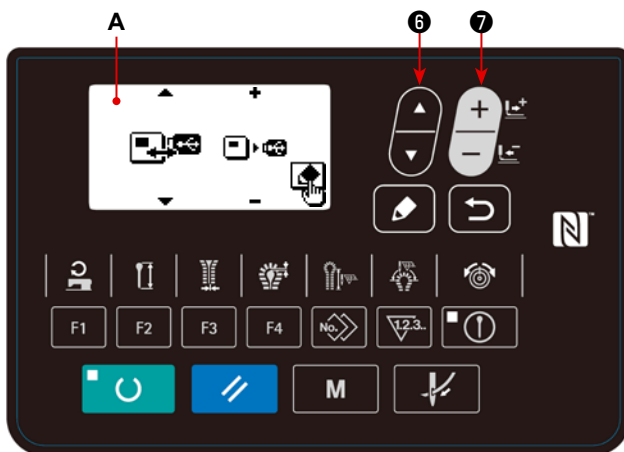

3) Selecting the communication direction

Press ITEM SELECT key  6 to display pictograph A which shows the communication direction selection.



Press DATA CHANGE key  7 to select the communication direction.

 : Data shown on the operation panel is written on the USB thumb drive.

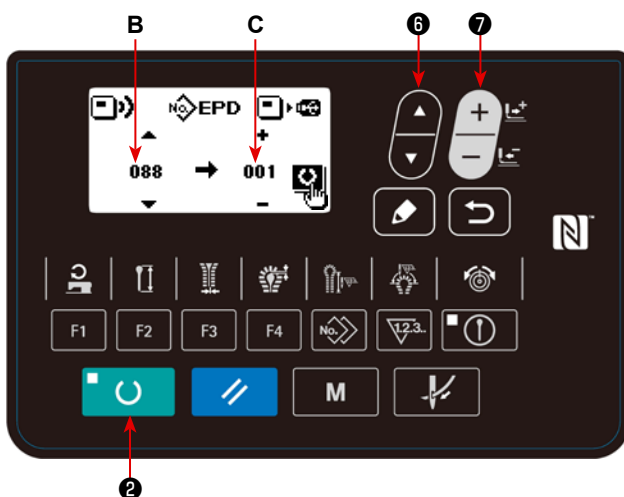
 : Data stored on the USB thumb drive is read into the operation panel.



4) Selecting the number

Press ITEM SELECT key  6 to select file No. B to be read. Press DATA CHANGE key  7 to select file No. C to be written.

Press READY key  2 to write the data in file No. C.

(1) USB thumb drive

① Precautions to be taken when handling USB devices

Do not leave the USB device or USB cable connected to the USB port while the sewing machine is in operation. The machine vibration can damage the port section resulting in loss of data stored on the USB device or breakage of the USB device or sewing machine.

- Do not insert/remove a USB device during reading/writing a program or sewing data. It may cause data breakage or malfunction.
- When the storage space of a USB device is partitioned, only one partition is accessible.
- Some type of the USB device may not be properly recognized by this sewing machine.
- JUKI does not compensate for loss of data stored on the USB device caused by using it with this sewing machine.
- When the panel displays the communication screen or pattern data list, the USB drive is not recognized even if you insert a medium into the slot.
- For USB devices and media such as CF(TM) cards, only one device/medium should be basically connected/inserted to/into the sewing machine. When two or more devices/media are connected/inserted, the machine will only recognize one of them. Refer to the USB specifications.
- Insert the USB connector into the USB terminal on the IP panel until it will go no further.
- Do not turn the power OFF while the data on the USB flash drive is being accessed.

② USB specifications

- Conform to USB 2.0 standard
- Applicable devices *1 ___ Storage devices such as USB memory, USB hub, FDD and card reader
- Not-applicable devices ___ CD drive, DVD drive, MO drive, tape drive, etc.
- Format supported ___ FD (floppy disk) FAT 12
Others (USB memory, etc.), FAT 12, FAT 16, FAT 32
- Applicable medium size ___ FD (floppy disk) 1.44MB, 720kB
Others (USB memory, etc.), 4.1MB ~ (2TB)
- Recognition of drives ___ For external devices such as a USB device, the device which is recognized first is accessed. However, when a medium is connected to the built-in media slot, the access to that medium will be given the highest priority. (Example: If a medium is inserted into the media slot even when the USB memory has already been connected to the USB port, the medium will be accessed.)
- Restriction on connection ___ Max. 10 devices (When the number of storage devices connected to the sewing machine has exceeded the maximum number, the 11th storage device and beyond will not be recognized unless they are once disconnected and re-connected.)
- Consumption current ___ The rated consumption current of the applicable USB devices is 500 mA at the maximum.

*1: JUKI does not guarantee operation of all applicable devices. Some device may not operate due to a compatibility problem.

(2) NFC

The operation panel supports NFC (Near Field Communication).

Sewing data, maintenance information or the like can be viewed, edited, copied, etc., on an Android terminal (such as tablet and smartphone) on which JUKI application for Android "JUKI Smart App" has been installed, by means of the NFC communication function.

Refer to the Instruction Manual for JUKI Smart App for details of JUKI application for Android "JUKI Smart App".

① Position of the NFC antenna

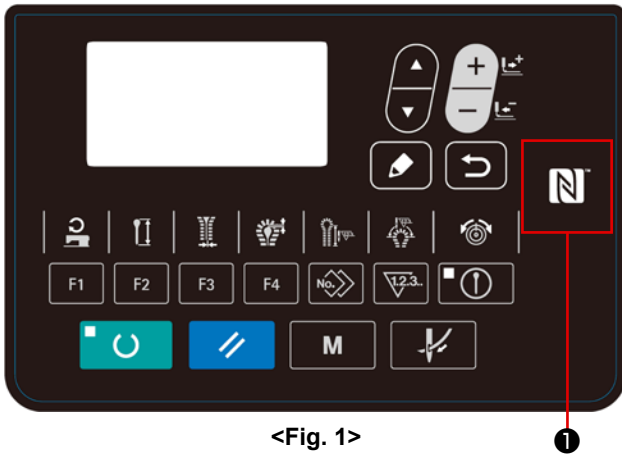

<Fig. 1>

[Position of the NFC antenna]

In the case of carrying out the NFC communication between the sewing machine and a tablet or smartphone, bring the antenna of the tablet or smartphone near to NFC mark ① as shown in Fig. 2.

* If the NFC communication has failed, error message will be displayed on the tablet/smartphone screen. When the error message is displayed on the screen, carry out the NFC communication again.

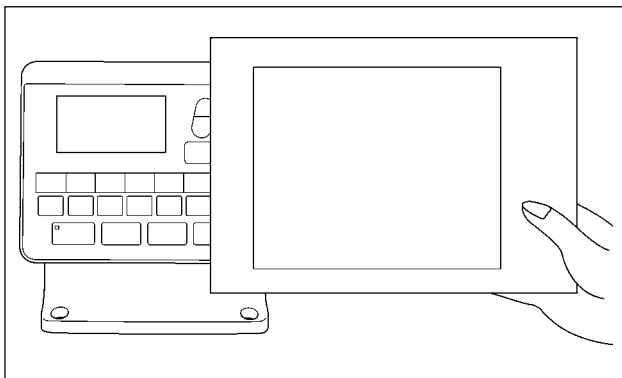

<Fig. 2>

② Precautions to be taken when handling NFC

- The position of the NFC antenna varies according to the tablet/smartphone used. Be sure to read the instruction manual of your device before using the NFC communication function.
- To use the NFC communication function, place the NFC communication function setting in "Enable" while referring to the instruction manual for your tablet/smartphone.

9-11. Setting the irregular work

In the case the sewing machine is not operated for a certain period of time, the work descriptions for that period can be input through the operation panel.

The data on the input work description can be collected and displayed by means of "JUKI Smart App".

Setting of irregular work should be carried by means of "JUKI Smart App". The set details can be checked on the operation panel.

1) Selecting the irregular work setting function

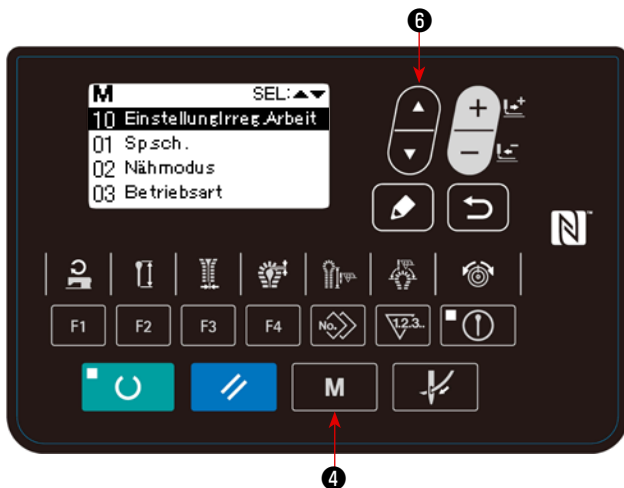

1. Keep MODE key **M** **4** held pressed for three seconds. Then, select "14. Setting the irregular work" with ITEM SELECT key **6**.

The "irregular work setting screen" is displayed.

2) Inputting the irregular work

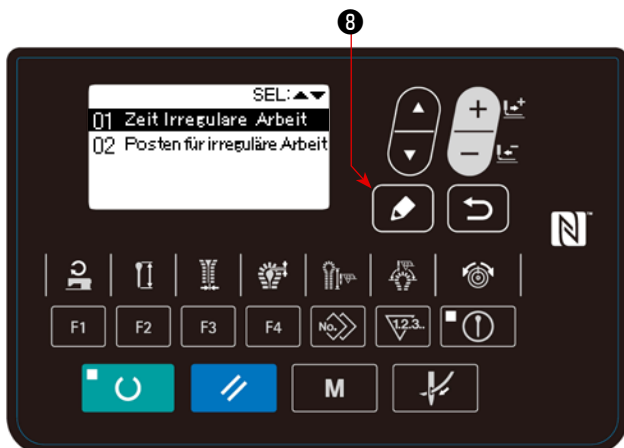

Enter the time during which the irregular work input screen is displayed in the case the sewing machine is not operated.

1. In the state where the "irregular work setting screen" is selected, press EDIT key **8**.

Select the "irregular work time" and press EDIT key **8**.

The "irregular work hours input screen" is displayed.

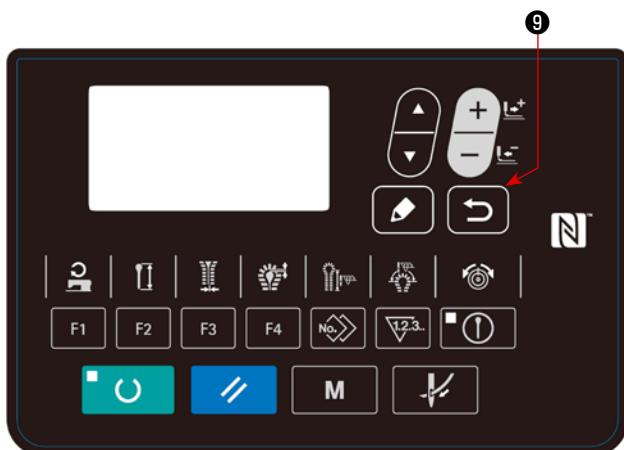

2. The preset time (in seconds) during which the irregular work input screen is displayed is displayed.

Range : 0 to 99 (Seconds)



Initial value : 0 (Function is turned)

Press RETURN key **9** to display the "irregular work setting screen".

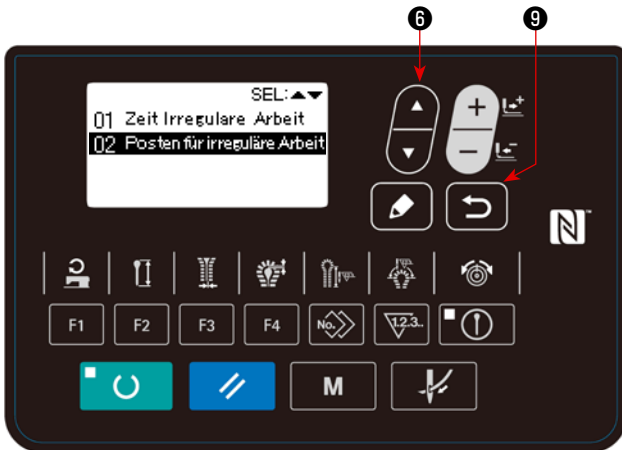

3) Displaying the "irregular work setting function"

Work items that are displayed on the irregular work input screen are displayed.
Carry out setting of work items by means of "JUKI Smart App".

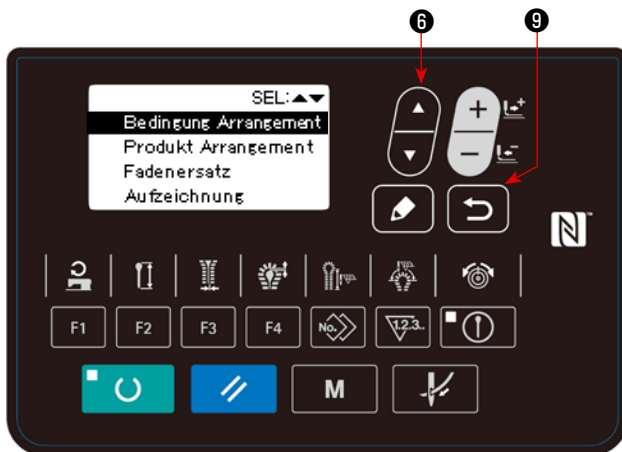

1. Press ITEM SELECT key  6 on the "Irregular work items setting screen".
Select the "setting irregular work items" and press RETURN key  9 to confirm the selection.
The "irregular work items setting screen" is displayed.



2. Work items can be checked by pressing ITEM SELECT key  6 .
Press RETURN key  9 to display the "irregular work setting screen".

* The work items are as listed below.

No.	Work items	No.	Work items
01	Condition maintenance	08	Work meeting
02	Product arrangement	09	Transport
03	Thread change	10	Transfer
04	Record	11	Waiting for work
05	Failure	12	Fatigue
06	Judgment	13	Errand
07	Correction	14	Omission of duty

10. MAINTENANCE

10-1. Looper thread trimming (overall thread trimmer type)

WARNING :



1. Turn OFF the power before starting the work so as to prevent accidents caused by abrupt start of the sewing machine.
2. To avoid unexpected personal injuries, be sure to keep away from the looper thread trimming knife during work.

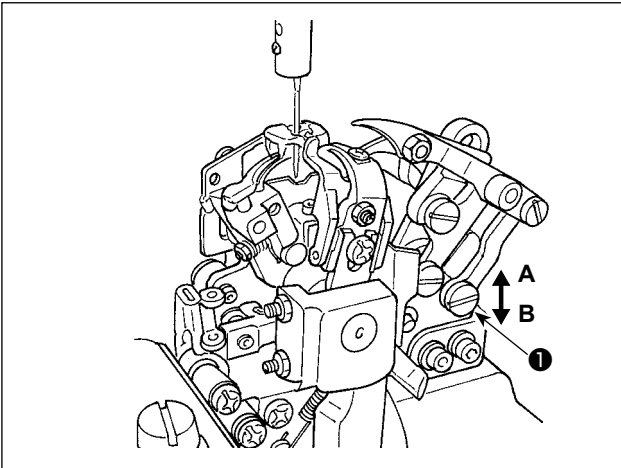

The looper trimming knife does not require re-adjustment when the sewing specifications are changed. However, the height of the looper trimming knife position has to be adjusted in the case the knife fails to catch and trim the looper thread after replacement of the knife.

- 1) To adjust the knife height, loosen screw ❶ and the nut located on the underside of the screw and change the height of screw ❶ and nut appropriately.
 - * If the knife trims the gimp but fails to trim the looper thread, the knife position is too high. Move screw ❶ and nut in direction A to decrease the knife height.
 - * If the knife trims the looper thread but fails to trim the gimp, the knife position is too low. Move screw ❶ and nut in direction B to increase the knife height.

- 2) Once the knife is positioned correctly, fix the knife by tightening screw ❶ and nut.



Whenever the knife height is changed, check to be sure that it does not interfere with other components such as the presser plate while the sewing machine is in operation.

10-2. Timing between the needle and the looper

DANGER :

Be sure carry out the work while observing the following in order to protect against pinching of hands, fingers and arms between the sewing machine and the bottom cover, which can result in serious injury, when you raise the sewing machine from its home position.



- Be sure to lock the hinge stopper to firmly secure the sewing machine in its raised position.

* Read and check "3-6. Raising and returning the sewing machine" p. 16.

WARNING :

1. Turn OFF the power before starting the work so as to prevent accidents caused by abrupt start of the sewing machine.
2. To avoid unexpected personal injuries, be sure to keep away from the looper thread trimming knife during work.

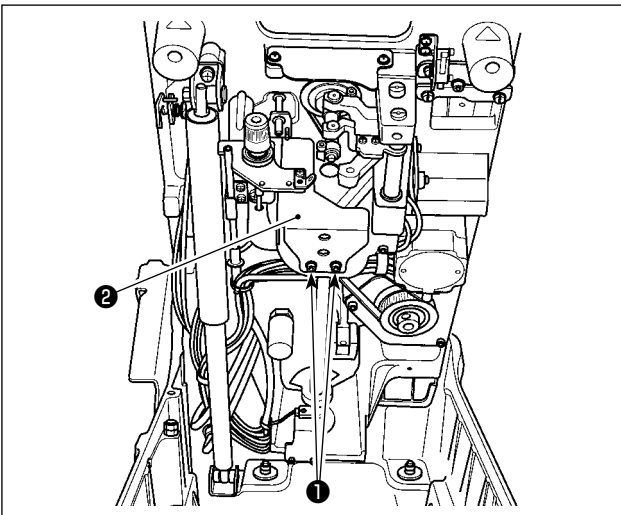

To adjust the looper cam, raise the machine head.

(Refer to "3-6. Raising and returning the sewing machine" p. 16 for how to raise the machine head.)

Remove screws ❶ to remove looper cover ❷. Then, carry out the adjustment.

After the completion of the work, attach the looper cover.



To adjust the timing between the needle and the looper, adjust the needle throwing width and check the needle bar height in advance.



The inside needle means the innermost needle entry and the outside needle means the outermost needle entry of the needle throwing width employed for sewing an eyelet buttonhole.

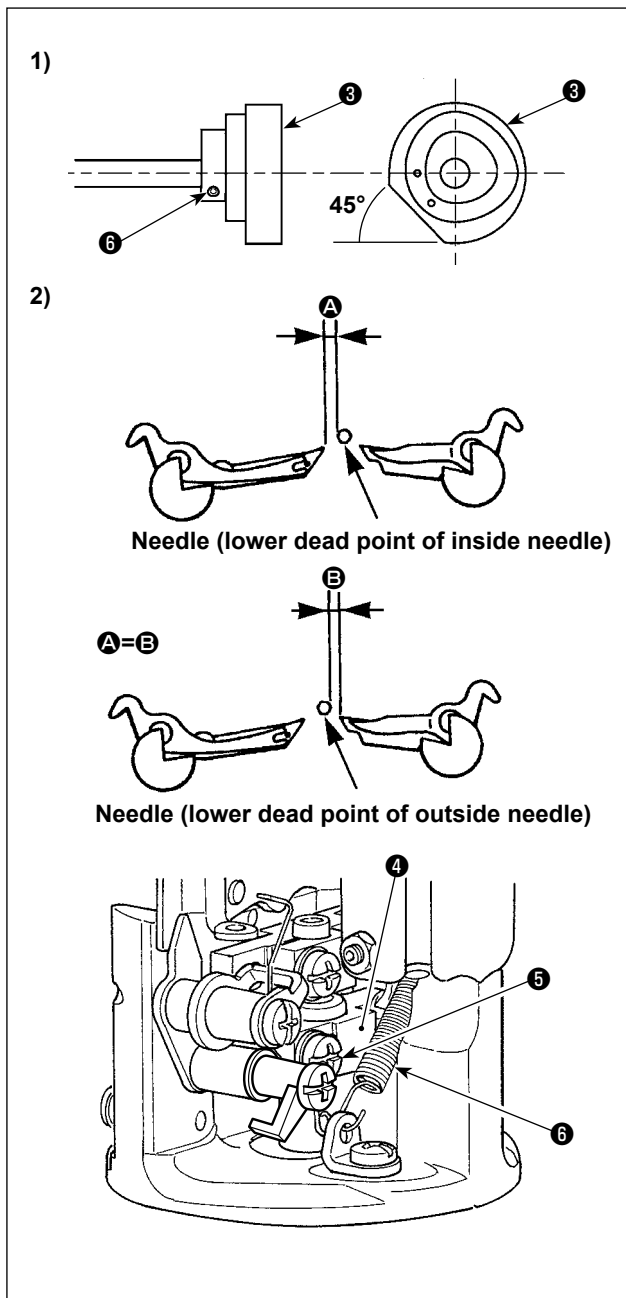

- 1) Loosen two setscrew **6** in the looper driving cam. Bring the needle bar to the lower dead point of the inside needle. Turn looper driving cam **3** by hand so that the flat plane of looper driving cam **3** faces to the lower left at 45° to horizontal, and temporarily tighten looper driving cam setscrew **6**.



When turning looper driving cam **3**, take care not to allow the hook driving shaft to turn together.

- 2) Loosen setscrew **5** in the looper driving shaft guide. Move looper driving shaft guide **4** up and down to adjust so that clearance **B** provided between the needle and the right looper and clearance **A** between the needle and the left looper are made to be equal in both cases when the needle bar is brought to the lower dead point of the outside needle and when the needle bar is brought to the lower dead point of the inside needle. Then, tighten setscrew **5**.



Take care not to damage or deform needle thread trimming spring **6**.

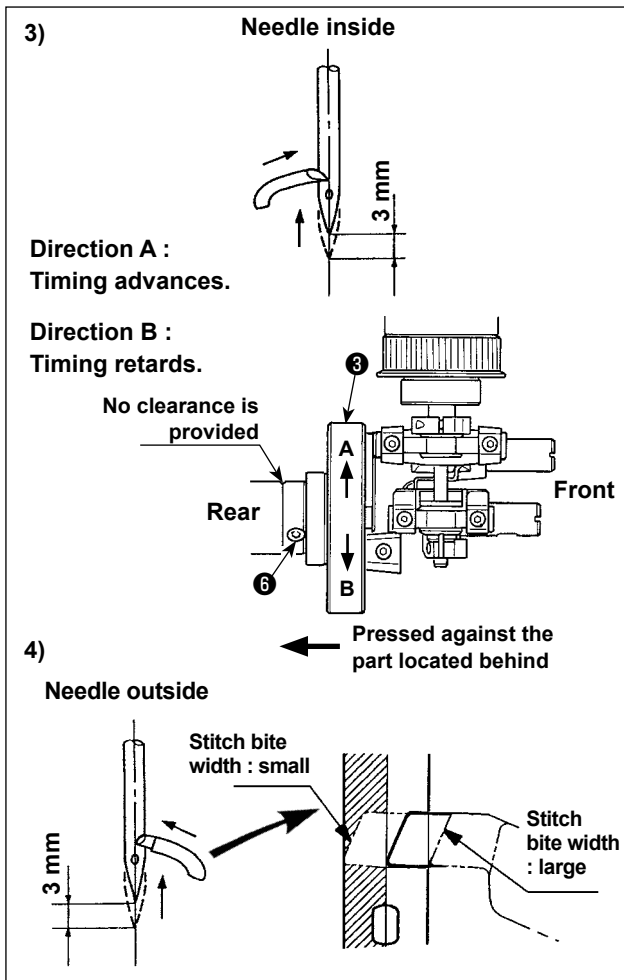

- 3) Adjust with looper driving cam ③, so that the blade point of the left looper is aligned with the center of the needle when the needle bar goes up 3 mm from the lower dead point of the inside needle. Then, fix the looper driving cam by tightening two setscrews ⑥ with driving cam ③ pressed against the part located behind it.

If stitch skipping due to the loop bending caused by faulty scooping of thread by the looper occurs when the needle throwing width is 2 mm or less, shift the looper driving cam in direction A to change the looper timing so that the left looper blade point is located at the center of the needle when the needle bar goes up from the inside lower dead point by 2.7 to 2.8 mm.

- 4) Similarly, check the position of the needle and that of the blade point of the looper when the needle bar goes up 3 mm from the lower dead point of the outside needle. The blade point is positioned approximately in the range of the left side of the needle. When it is outside the range, check again steps 2) and 3).

After performing the looper timing adjustment, when the stitch bite width is changed in case of ① to ③ described below, perform steps 1) to 4) whenever the case occurs.

- ① When the stitch bite width in terms of that at the time of looper timing adjustment is changed more than ± 0.3 mm.

Even when the change of the stitch bite width is within ± 0.3 mm :

- ② When the stitch bite width is more than 3.4 mm.
- ③ When sewing heavy-weight materials or overlapped section where needle is apt to be bent.

10-3. Height of the needle bar

(1) Adjusting the needle bar height



WARNING :

1. Turn OFF the power before starting the work so as to prevent accidents caused by abrupt start of the sewing machine.
2. To avoid unexpected personal injuries, be sure to keep away from the looper thread trimming knife during work.

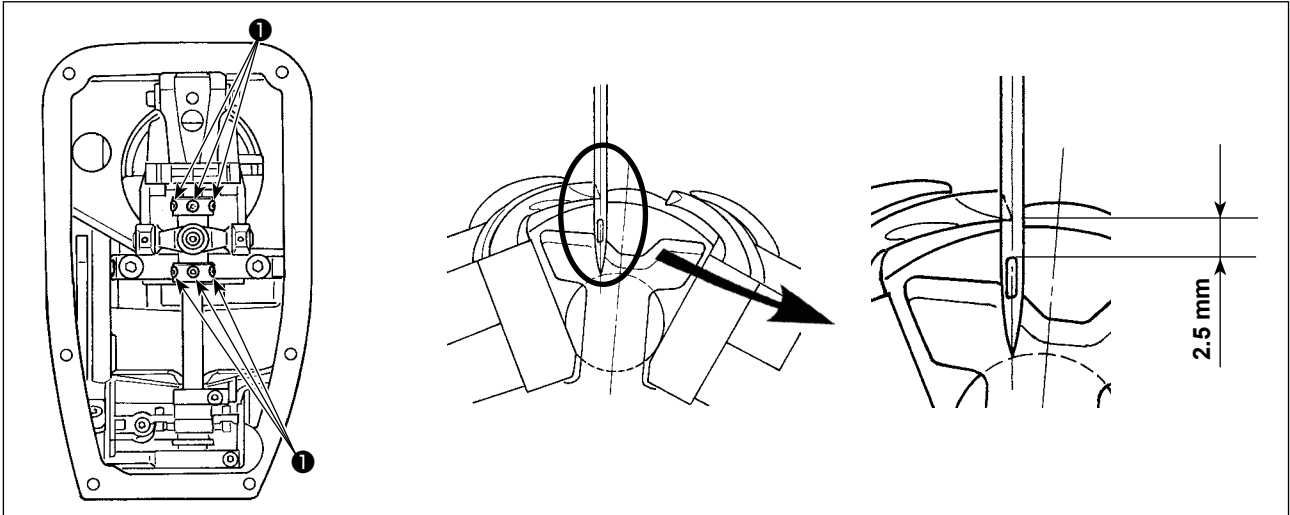

Loosen screw ① and adjust the height of the needle bar so that the top of the needle eyelet is spaced 2.5 mm from the blade point of the looper when the needle bar ascends 3 mm from its inside lower dead point and the needle and left looper are positioned at the inside needle scooping position.

(2) Reference height of the needle bar

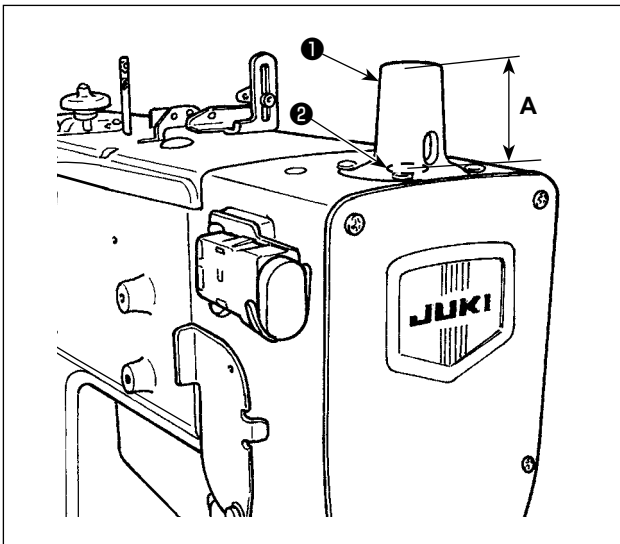

For the needle bar height, take dimension **A** from the top end of the needle bar ② to the top surface of needle bar cover ① shown in the left figure as reference.

Dimension **A** at each point

Lower dead point of needle bar... 42.5 mm
(when the looper timing is 3 mm)

Looper scooping timing ... 39.5 mm
(when the looper timing is 3 mm)



Carry out the adjustment after the completion of adjustment described in "10-2. Timing between the needle and the looper" p. 95.

10-4. Adjustment to prevent triangular stitch skipping in the case of a narrow needle throwing width

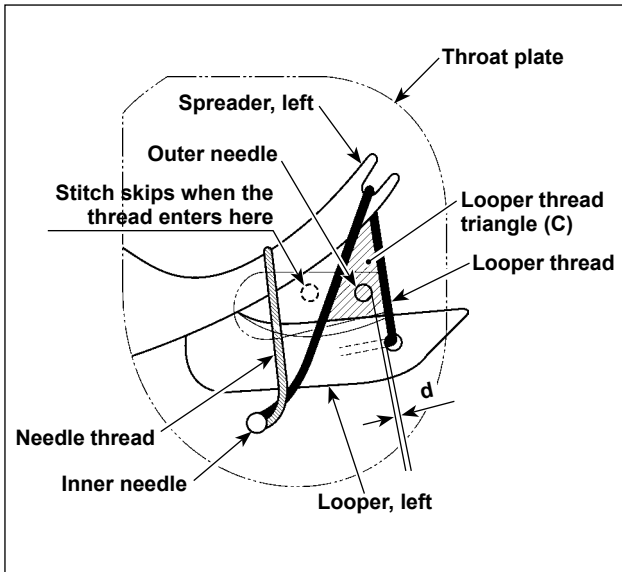

For sewing with the narrow needle throwing width of 2 mm or less, the outer needle enters the left side of the looper thread triangle (C section) when the outer needle comes down during sewing in the standard adjustment state. This can cause stitch skipping. In this case, carry out the following adjustment after the completion of the adjustment described in "10-2. Timing between the needle and the looper" p. 95 and "10-3. (1) Adjusting the needle bar height" p. 98 completed.

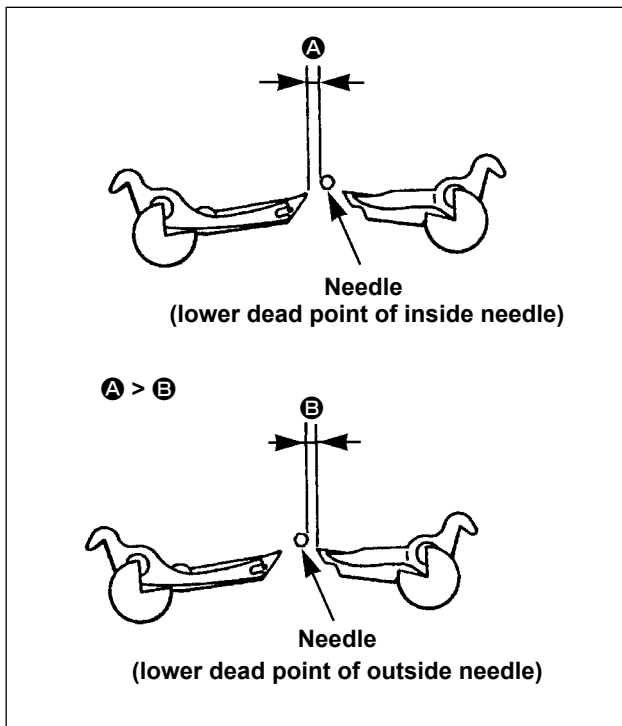

- 1) Turn the hand pulley by hand when the looper thread is hooked on the looper to lower the outer needle.
- 2) Loosen setscrew ❶ in the looper driving shaft guide. Move looper driving shaft guide ❷ upward to adjust so that the outer needle enters the looper thread triangle (C section) when the needle intersects the looper, left; i.e., A is larger than B ($A > B$).

A guide of adjustment

When the looper timing is 2.7 mm:

Values A and B

A = Approx. 4 mm

B = Approx. 3 mm

- 3) Determine the position of looper driving shaft guide ❷ so that clearance d provided between the outer needle and the looper thread is minimized. Then, fix the looper driving shaft guide with setscrew ❶.



Take care not to damage or deform needle thread trimming spring ❸.



Even when the outer needle enters the looper thread triangle (C section) by turning the hand pulley by hand, the needle sometimes enters outside the C section resulting in stitch skipping during sewing. If stitch skipping occurs, adjust dimension d as small as possible so that the outer thread enters C section during sewing.

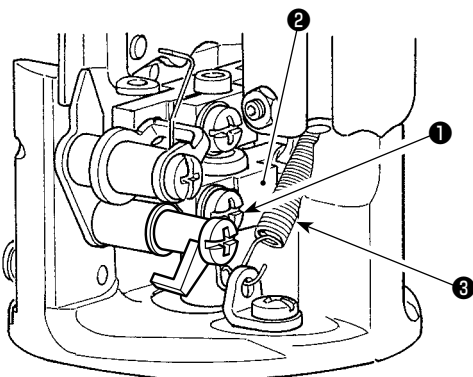

10-5. Clearance between the needle and the looper

WARNING :



1. Turn OFF the power before starting the work so as to prevent accidents caused by abrupt start of the sewing machine.
2. To avoid unexpected personal injuries, be sure to keep away from the looper thread trimming knife during work.

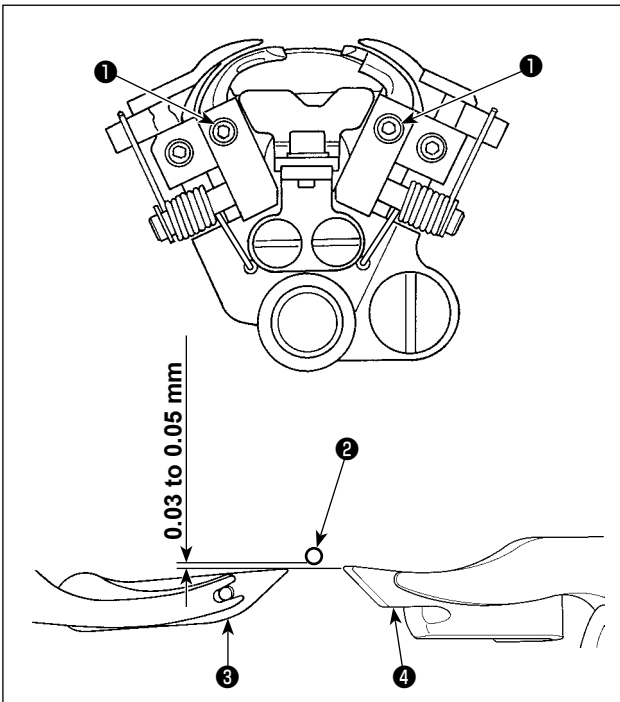

The standard adjustment value of the clearance between the needle and the looper is 0.03 to 0.05 mm. Loosen looper setscrew ① and adjust the clearance between needle ② and left looper ③, and between the needle and right looper ④. Then fix the loopers in place.

1. When the clearance between the needle and the looper is adjusted, the spreader height has also to be adjusted simultaneously as described in "10-7. Clearance between the spreader and looper and the opening timing of the spreader" p. 101.



2. Be sure to adjust the clearance whenever the needle size is changed.

10-6. Adjusting the needle guard

WARNING :



1. Turn OFF the power before starting the work so as to prevent accidents caused by abrupt start of the sewing machine.
2. To avoid unexpected personal injuries, be sure to keep away from the looper thread trimming knife during work.

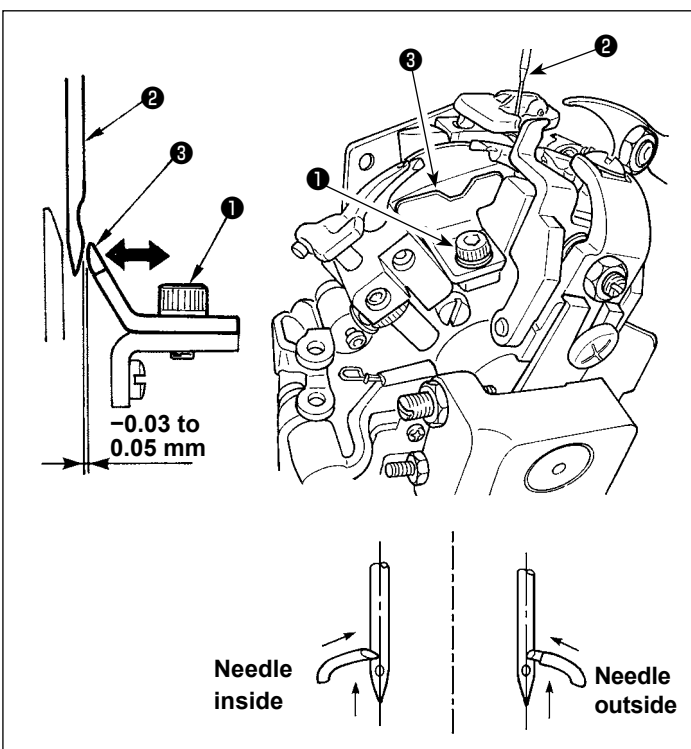

- 1) Loosen setscrew ①.
- 2) Set the clearance between needle ② and needle guard ③ to -0.03 to 0.05 mm. However, the clearance should be adjusted to smaller than the clearance provided between the needle and the looper.
- 3) Tighten setscrew ①.
- 4) Check the position both at the time of needle inside and of needle outside.



Be sure to adjust the needle guard when the needle size is changed or when the adjustment of needle and looper is performed. Adjust the clearance when needle aligns with the looper blade point at the inside and outside respectively.



In the case of sewing a heavy-weight material, adjust the clearance provided between the needle ② and needle guard ③ to 0 (zero).

10-7. Clearance between the spreader and looper and the opening timing of the spreader



WARNING :

1. Turn OFF the power before starting the work so as to prevent accidents caused by abrupt start of the sewing machine.
2. To avoid unexpected personal injuries, be sure to keep away from the looper thread trimming knife during work.

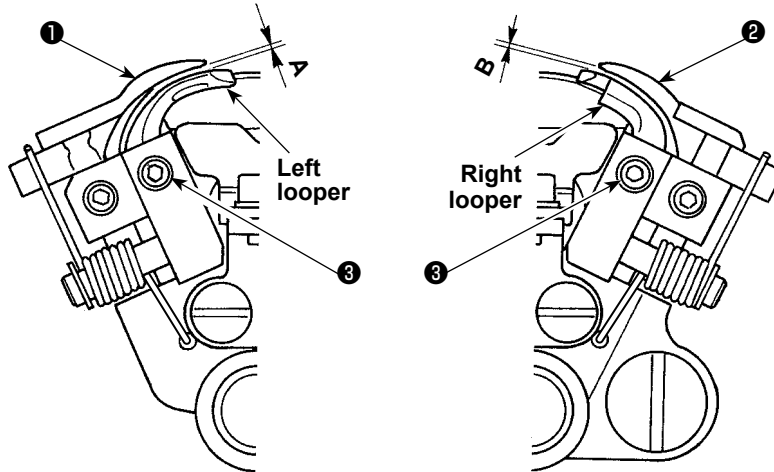

Loosen setscrew ③ which fixed the looper. Then, adjust the clearance by changing the vertical position of the looper.

● Clearance of left spreader ①

Adjust so that clearance **A** of 0.1 to 0.2 mm is provided between the under surface of the top end of left spreader ① and the top surface of the left looper and so that a resistance is applied to one thread when it passes between them.

● Clearance of right spreader ②

The allowable range of clearance **B** provided between the under surface of right spreader ② and the top surface of right looper is 0 to 0.05 mm.



1. When the vertical position of the looper is adjusted, the clearance between the needle and the looper has also to be adjusted simultaneously as described in "10-5. Clearance between the needle and the looper" p. 100.
2. If the clearance provided between the spreader and the looper is outside the adjustable range, stitch skipping and needle breakage can occur.

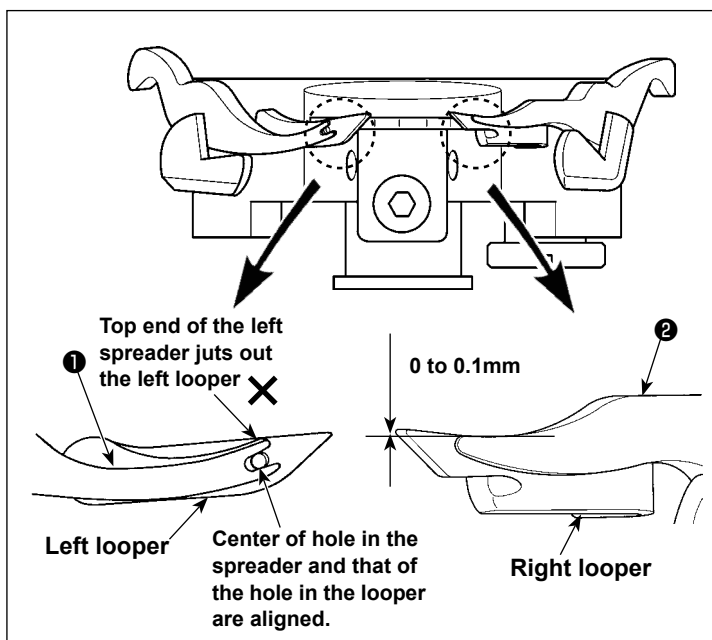

● Installation position of the left spreader

The center of the forked section at the top of left spreader ① is aligned with the center of the looper thread hole in the left looper.



When the top end of the left spreader in terms of the left looper protrudes, stitch skipping will result.

● Installation position of the right spreader

The internal surface of the right spreader ② is designed to be aligned with the internal surface of the spreader. Adjust the top end of the spreader so that it retracts 0 to 0.1 mm from the inside of the right looper.

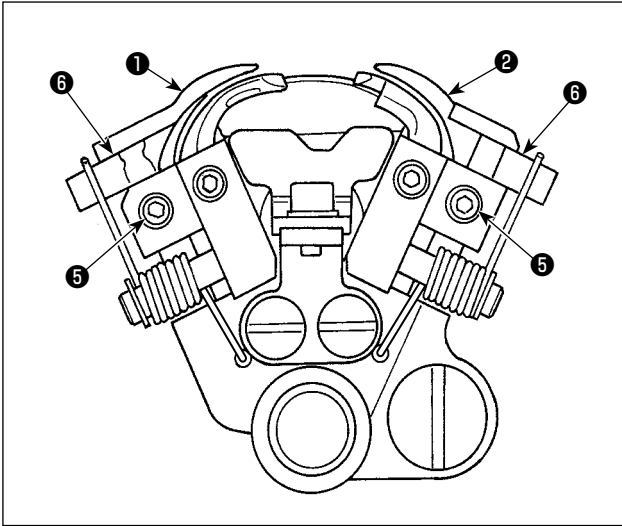

Loosen setscrew **5** in the spreader stopper and adjust the position of spreader stopper **6**. Then fix the spreader in place. (Make the same adjustment for both left/right spreaders.)

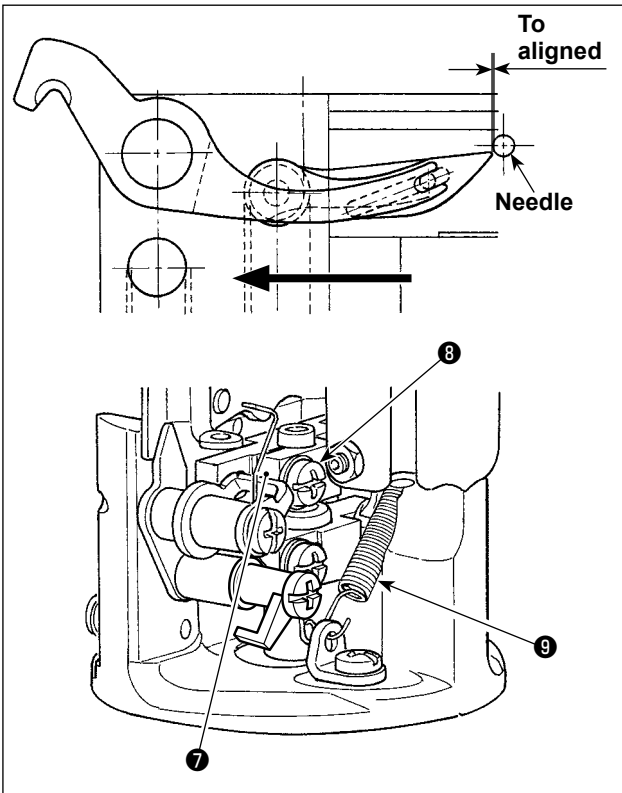

● **Timing to open/close the spreaders**

In the case of the outer needle, the correct timing is such that the left spreader completely closes at the moment when the end face (side face) of the needle is aligned with the top end of the left looper while the needle bar comes down and the left looper travels backward.

When the inner needle rests at its lower dead point, the right spreader is in the closed state.

Caution Make sure of the width or the timing when the stitch bite width is changed or after performing the looper timing adjustment.

Loosen setscrew **8** of spreader driving shaft guide **7**. Adjust the timing by moving the guide up and down. Then, fix the spreader driving shaft guide by tightening the setscrew.

Caution Take care not to damage or deform needle thread trimming spring **9**.

10-8. Height of the throat plate

(1) Height of the throat plate

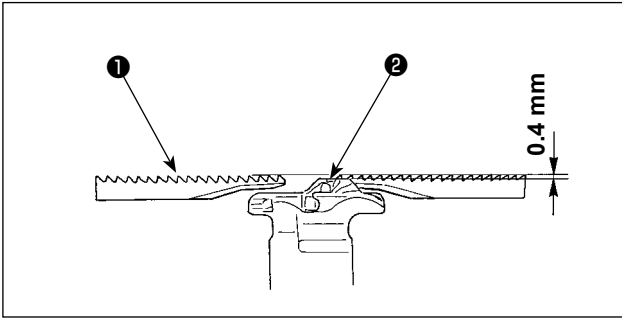

Install the throat plate at the position where top surface ② of the throat plate is 0.4 mm below top surface ① of the support plate.

(2) Adjusting the height of the throat plate

The height of the throat plate should be adjusted in the following procedure.

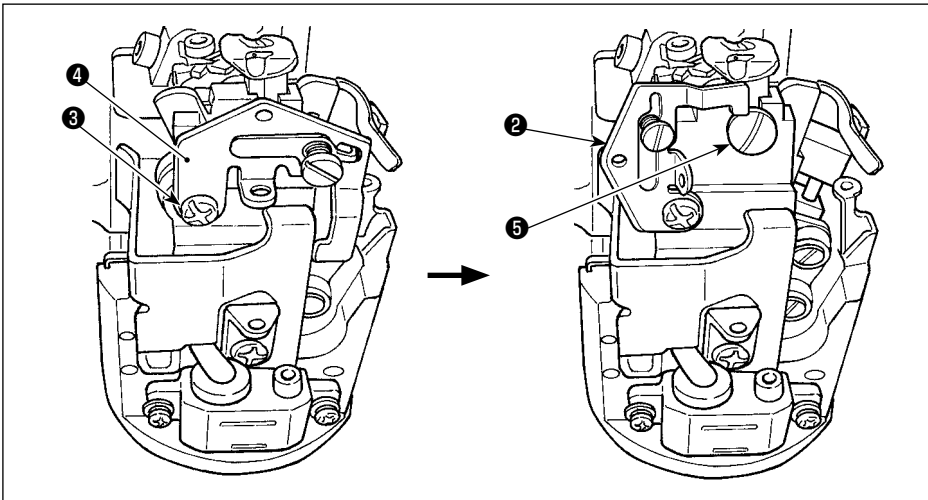

- 1) Loosen screw ③ and shift gimp guide ④.
- 2) Loosen throat plate setscrew ⑤ to remove throat plate ②.

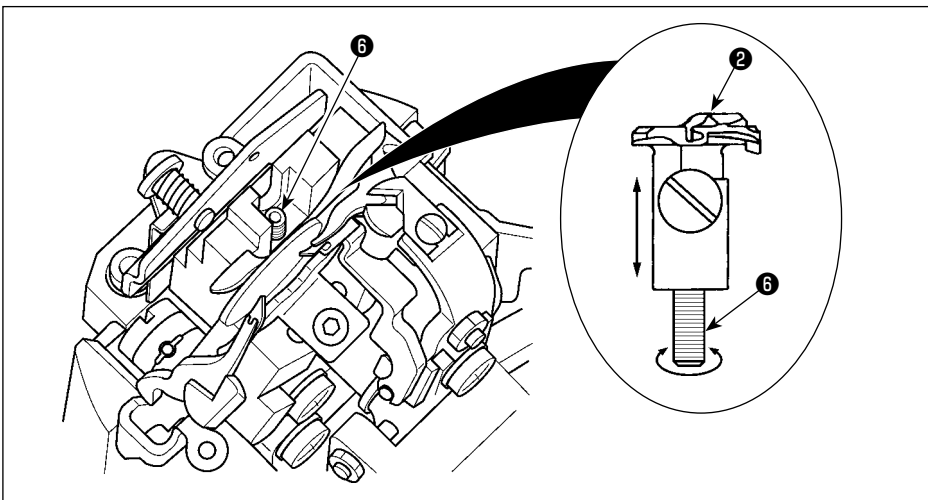

- 3) Adjust the height of the throat plate by turning screw ⑥ located under the throat plate to change the screw height.
- 4) Adjust the screw height so that the height of the throat plate and that of work clamp support plate ① are adjusted to 0.4 mm and fix the throat plate ② with its underside pressed against screw ⑥.

- 5) After the completion of the throat plate height, return gimp guide ④ to its home position and tighten screw ③.

10-9. Position of the presser foot



WARNING :

1. Turn OFF the power before starting the work so as to prevent accidents caused by abrupt start of the sewing machine.
2. To avoid unexpected personal injuries, be sure to keep away from the looper thread trimming knife during work.

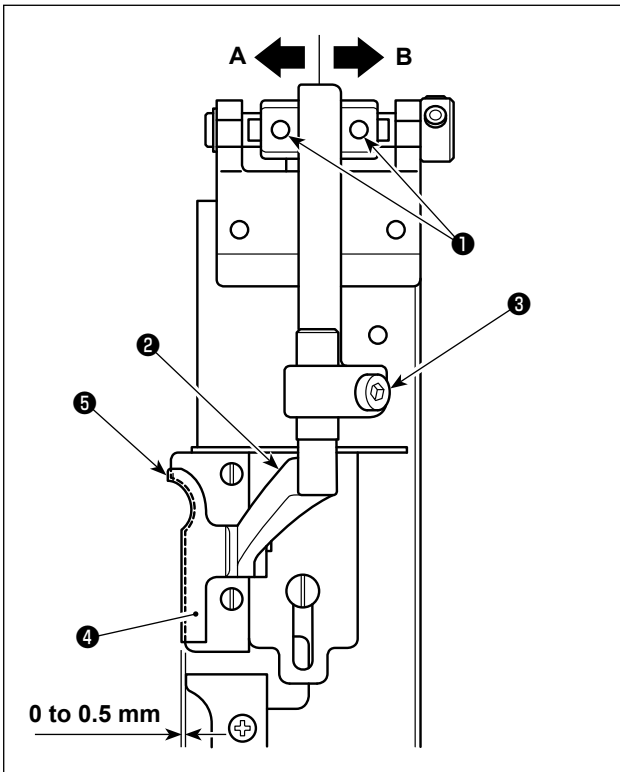

Adjust the protruding amount of presser foot, right ④ from support plate, right ⑤ to 0 to 0.5 mm.

Loosen two setscrews ① in the presser arm base and adjust the protruding amount by moving the base in direction **A** or **B**. After the adjustment, fix the presser arm base by tightening the setscrews.

* Adjust the presser foot, left in the manner as described above.

* The front or rear inclination can be adjusted with presser arm setscrew ③.

10-10. Adjusting the knife dropping position



WARNING :

1. Turn OFF the power before starting the work so as to prevent accidents caused by abrupt start of the sewing machine.
2. To avoid unexpected personal injuries, be sure to keep away from the looper thread trimming knife during work.

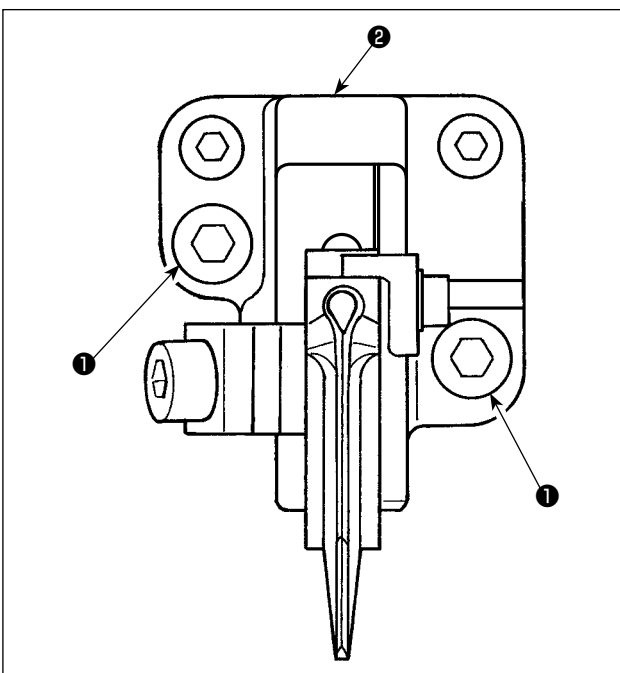

If the cloth trimming position deviates from the center, loosen setscrew ① in the knife base and adjust knife base ② to the right or left.

After the adjustment, fix the knife base by tightening setscrew ①.



If the cloth trimming position deviates from the center, troubles such that the finished seam is cut at the time of trimming the cloth.

10-11. Installing position of the needle thread trimming knife



WARNING :

1. Turn OFF the power before starting the work so as to prevent accidents caused by abrupt start of the sewing machine.
2. To avoid unexpected personal injuries, be sure to keep away from the looper thread trimming knife during work.

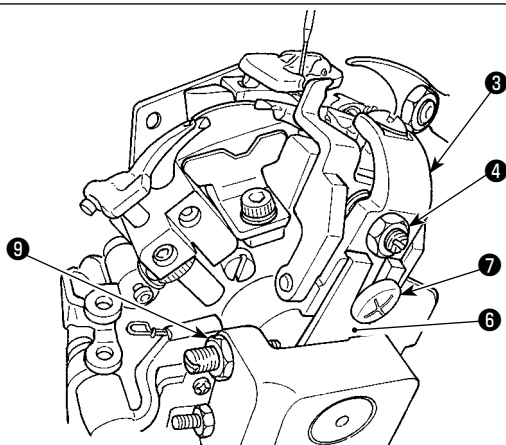
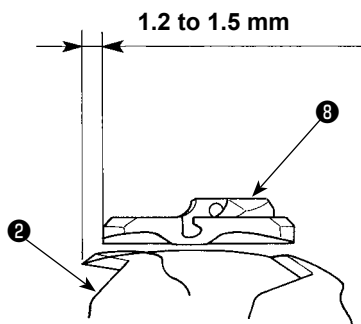
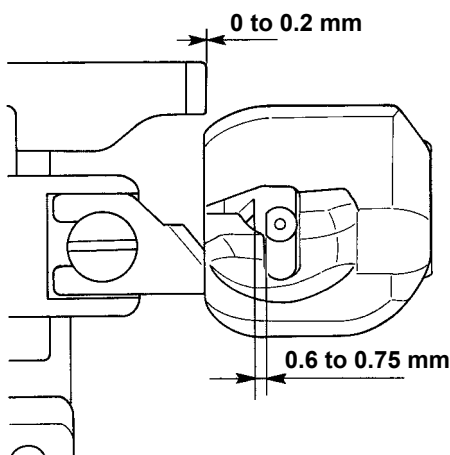
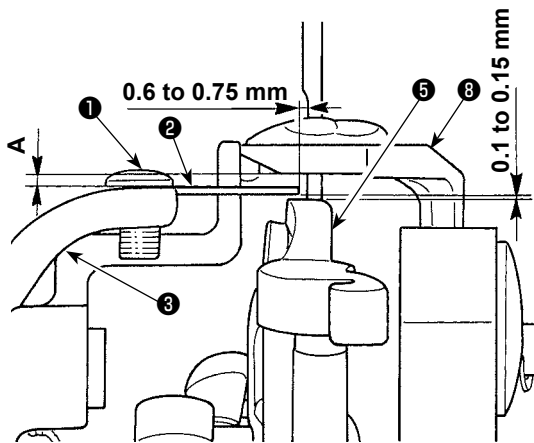

- 1) The clearance between needle thread trimming knife ② and the needle is approximately 0.6 to 0.75 mm.

Loosen setscrew ① and move needle thread trimming knife ② to adjust the clearance.

- 2) To adjust the height of needle thread trimming knife ②, loosen setscrew ⑦ and move needle thread trimming knife adjusting base ③ up or down to adjust the clearance between the needle thread trimming knife and spreader, right ⑤ to 0.1 to 0.15 mm.

At this time, make sure that clearance A is provided between the needle thread trimming knife and the throat plate.



When needle thread trimming knife ② comes in contact with spreader, right ⑤, breakage of components will be caused.

- 3) The operating position of needle thread trimming knife ② is the position where needle thread trimming knife ② juts out from throat plate ⑧ by 1.2 to 1.5 mm when needle thread trimming actuating arm ⑥ is moved counterclockwise until stopper B ⑨ of the needle thread trimming actuating arm comes in contact with the needle thread trimming knife actuating arm ⑥.

In the case adjustment is required, loosen needle thread trimming knife actuating arm stopper B ⑨, and then adjust the screw jutting amount.

- 4) Adjust the overlapping amount between the bobbin thread presser and the front end section of the throat plate to 0 to 0.2 mm.

Adjust the overlapping amount by loosening nut ④ and changing the jutting amount of the screw.

10-12. Cleaning



WARNING :

1. Turn OFF the power before starting the work so as to prevent accidents caused by abrupt start of the sewing machine.
2. To avoid unexpected personal injuries, be sure to keep away from the looper thread trimming knife during work.

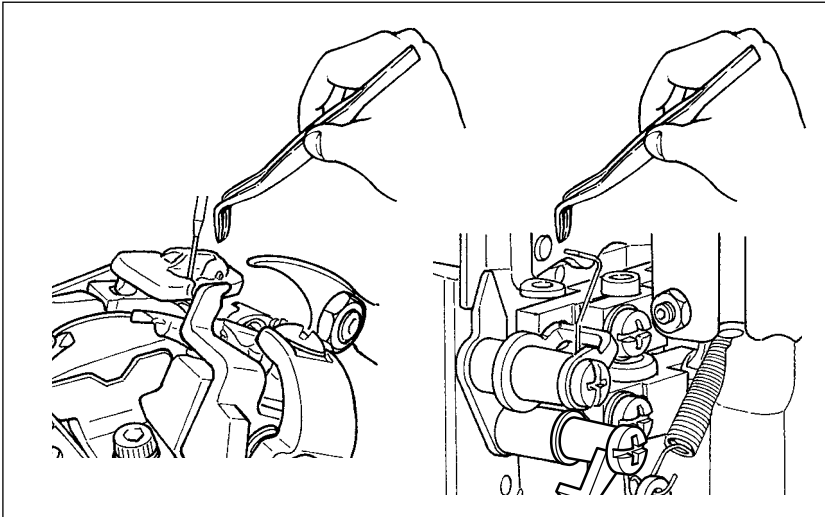

Thread waste may be sewn in the seam. To prevent this, remove thread waste and dust from the throat plate and the thread guide if accumulated.

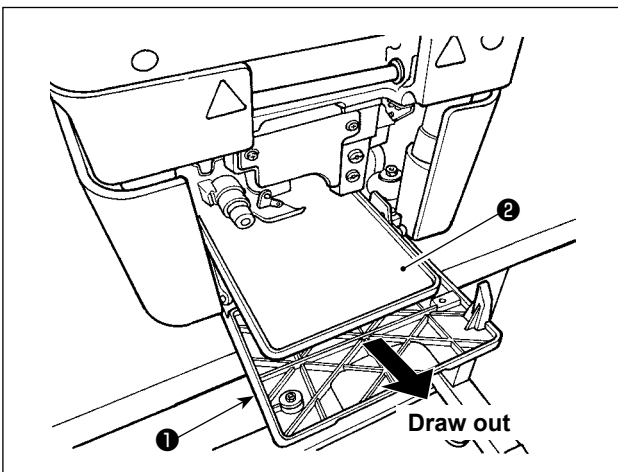

When thread waste has accumulated in the dust tray, open front cover ❶, draw dust tray ❷ and remove the accumulated thread waste.

After the removal of thread waste, set dust tray ❷ in its home position and close the front cover.

10-13. Draining



WARNING :

- Turn OFF the power before starting the work so as to prevent accidents caused by abrupt start of the sewing machine.

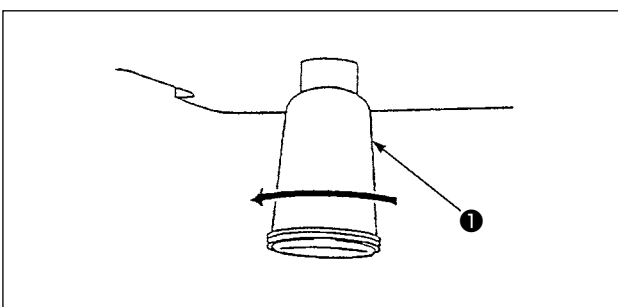

When oil has accumulated in poly oiler ❶ installed under the bottom cover, remove poly oiler ❶ to discard the oil.

10-14. Replacing consumables

(1) Worn-out of the hammer face



WARNING :

1. Turn OFF the power before starting the work so as to prevent accidents caused by abrupt start of the sewing machine.
2. To avoid unexpected personal injuries, be sure to keep away from the looper thread trimming knife during work.

Contact face of the hammer with the cloth cutting knife.

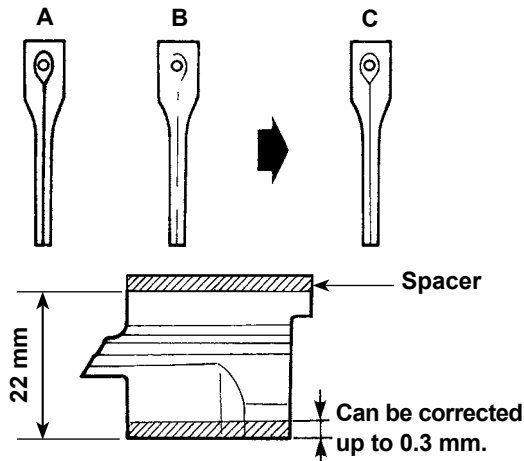

- 1) Remove the hammer and check the condition of the hammer surface. (Refer to "[10-14. \(2\) Replacing the cloth cutting knife and the hammer](#)" p.108.)
- 2) When the knife mark is too deep, the knife mark is duplicate (**A** of Fig. on the left side) by using another knife or the knife mark is partially formed and not formed on the whole surface (**B** of Fig. on the left side), grind the face with an oil stone or the like so that the knife mark becomes uniform.

Whenever the hammer is adjusted, a 0.1 to 0.3 mm spacer has to be adhered on the top surface according to the grinding amount to adjust the height to check the sharpness of the knife blades. If the sharpness checking proves poor sharpness, select a 0.1 to 0.3 mm spacer and place it between the hammer and the cloth trimming arm.



The 0.1 to 0.3 mm spacer has to be purchased separately.

Part number: 40115638 SPACER_01 (Thickness: 0.1 mm)

40115639 SPACER_02 (Thickness: 0.2 mm)

40115640 SPACER_03 (Thickness: 0.3 mm)

- 3) When the cloth cannot be precisely cut although the hammer is properly corrected, check the state of worn-out of the blade tip of the cloth cutting knife.



1. When replacing the knife, use a new hammer or a corrected hammer.

Breakage of the blade tip of the cloth cutting knife may occur.

2. The grinding amount of the hammer should not exceed 0.3 mm. If the knife sharpness cannot be re-obtained by grinding it to the limit, replace the hammer with a new one.

(2) Replacing the cloth cutting knife and the hammer



WARNING :

1. Turn OFF the power before starting the work so as to prevent accidents caused by abrupt start of the sewing machine.
2. To avoid unexpected personal injuries, be sure to keep away from the looper thread trimming knife during work.

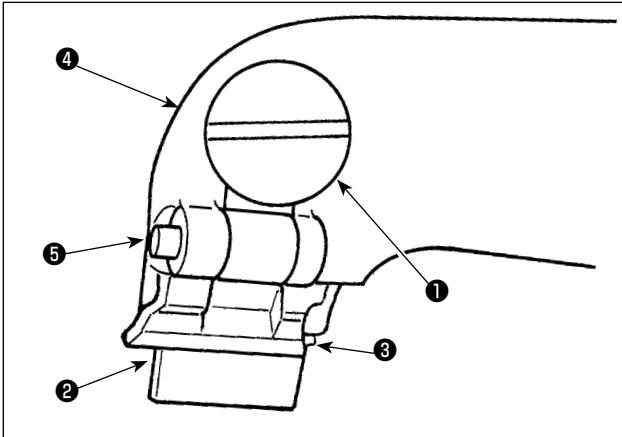

■ Replacing the hammer

- 1) Loosen thumbscrew ① and remove hammer ②.
- 2) Tighten thumbscrew ① with the new hammer pressed against stopper ③.

1. Stopper ③ is for positioning. Do not move it.

2. Knife spacer ⑤ for adjusting the knife height has been factory-placed between hammer ② and knife arm ④ at the time of shipment. When replacing the hammer, be sure to place female spacer ⑤ between the hammer and the knife arm without exception.



Knife spacer ⑤ is placed between the hammer and the knife arm for adjusting the knife height. Three different kinds of spacers are supplied with the unit; i.e., 0.1 mm, 0.2 mm and 0.3 mm in thickness.

* 0.1 mm thick spacer: Part number 40115638

* 0.2 mm thick spacer: Part number 40115639

* 0.3 mm thick spacer: Part number 40115640



If the knife blade and the hammer fail to engage properly with the factory-placed spacer after the replacement of the knife or the hammer, replace the spacer with another spacer of appropriate thickness.

Reference for the adjustment of the knife spacer height

- The top point side of eyelet buttonhole cannot be trimmed.
→ Replace the spacer with a thicker one.
- The end point side of eyelet buttonhole cannot be trimmed.
→ Replace the spacer with a thinner one.

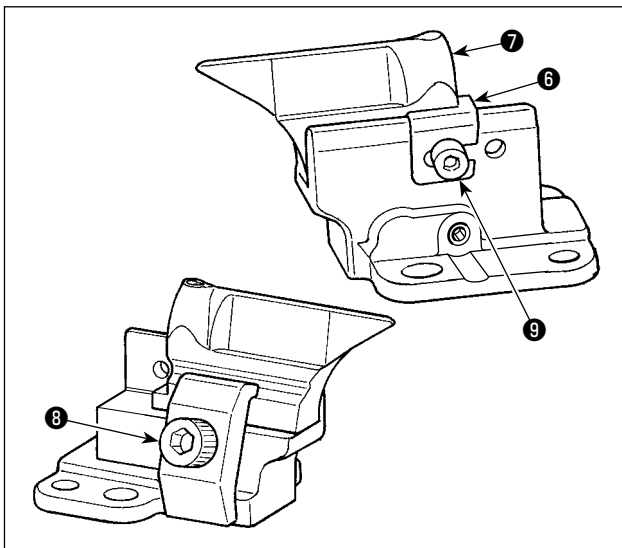

■ Replacing the cloth trimming knife

- 1) Loosen setscrew ⑧ and remove cloth trimming knife ⑦.
- 2) Tighten setscrew ⑧ with the new knife pressed against stopper ⑥.

Do not loosen screw ⑨ of stopper ⑥ since the distance from the center of needle to the crest of the cloth trimming knife eyelet has been factory-adjusted to 54 mm.



1. After you have changed the cloth trimming knife, match the knife size and the knife number displayed on the operation panel.

Refer to "7-1. Setting the knife No." p. 54 and "11-4. Cloth cutting knife" p. 113 for details.

2. Use the cloth cutting knife and the hammer as a set. If the cloth trimming knife and the hammer are not used as a set, two different blade marks will be made on the material. This means that the material cannot be cut with accuracy. As a result, breakage of the cloth trimming knife can be caused.



(3) Replacing the looper thread trimming knife (overall thread trimmer type)



WARNING :

1. Turn OFF the power before starting the work so as to prevent accidents caused by abrupt start of the sewing machine.
2. To avoid unexpected personal injuries, be sure to keep away from the looper thread trimming knife during work.

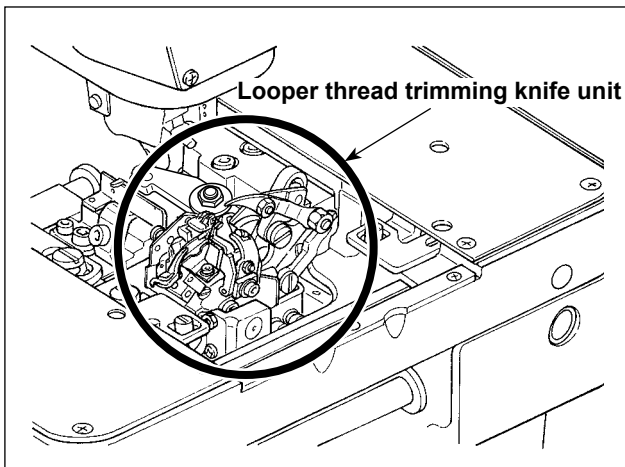

When the looper thread is not cut sharply, replace the looper thread trimming knife with a new one. The part number of the looper thread trimming knife is 40115260.

[Replacement procedure]

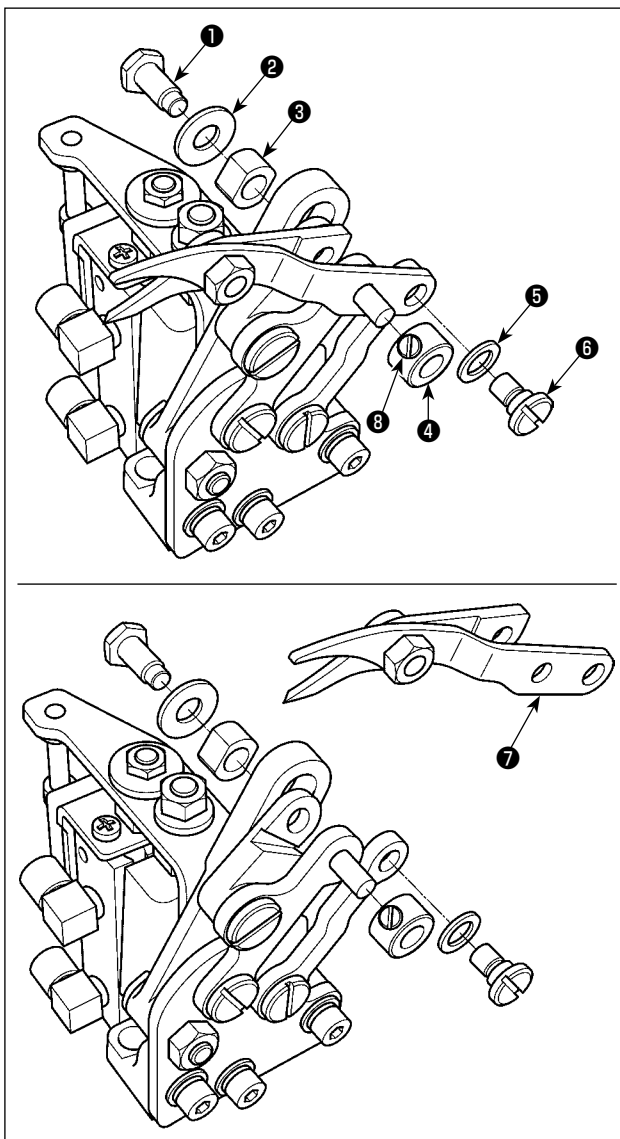

- 1) Close the air cock (refer to "[3-14. Installing the air hose](#)" p. 28) to remove air.
- 2) Remove screw ①, washer ② and square die ③.
- 3) Loosen the setscrew ⑧ to remove collar ④.
- 4) Remove screw ⑥ and washer ⑤.
- 5) Remove knife unit ⑦. Assemble a new knife unit (part number: 40115260) and fix it by tightening the screw.
- 6) Open the air cock (refer to "[3-14. Installing the air hose](#)" p. 28) to supply air.

(4) Replacing the needle thread trimming knife



WARNING :

1. Turn OFF the power before starting the work so as to prevent accidents caused by abrupt start of the sewing machine.
2. To avoid unexpected personal injuries, be sure to keep away from the bobbin thread trimming knife and needle thread trimming knife during the adjustment procedure.

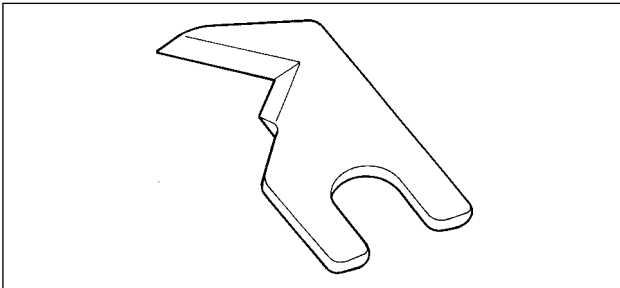

When the needle thread is not cut sharply, replace the needle thread trimming knife with a new one. The part number of the needle thread trimming knife is 40115277.

Refer to "**10-11. Installing position of the needle thread trimming knife**" p. 105 for how to install the knife.

(5) Changing the thread trimmer retaining plate (needle thread trimmer type)



WARNING :

1. Turn OFF the power before starting the work so as to prevent accidents caused by abrupt start of the sewing machine.
2. To avoid unexpected personal injuries, be sure to keep away from the looper thread trimming knife during work.

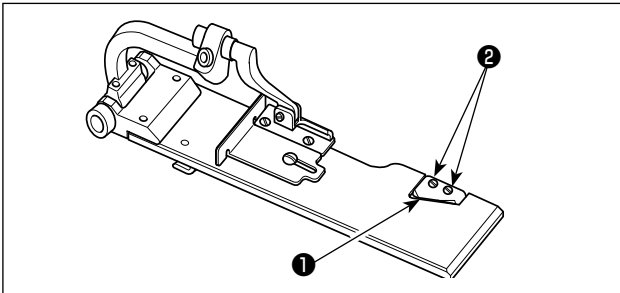

When the looper thread and the gimp are not smoothly trimmed, replace thread trimmer retaining plate ❶ with a new one.

Remove screws ❷ and replace the thread trimmer retaining plate with a new one. Fix the new thread trimmer retaining plate with two screws ❷.

(6) Standard of replacing time of the gas spring



DANGER :

There is a risk of pinching of hand, fingers and arms to cause a serious injury if you raise it when the gas spring does not function, since the sewing machine is very heavy in weight. In order to prevent an accident, be sure to replace the gas spring with a new one before it is too late according to the standard of replacing time (as described below).

WARNING :

1. Turn OFF the power before starting the work so as to prevent accidents caused by abrupt start of the sewing machine.
2. To avoid unexpected personal injuries, be sure to keep away from the looper thread trimming knife during work.

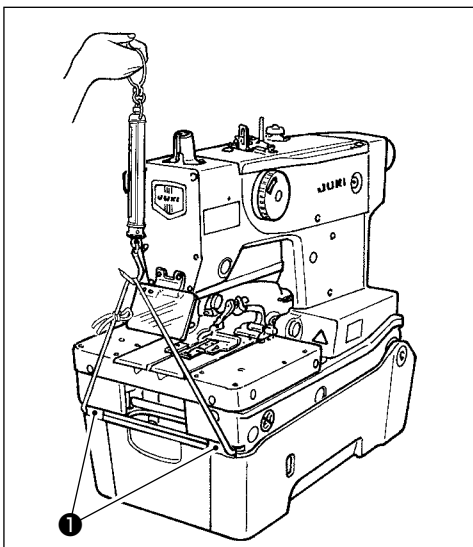

Gas spring is one of the consumables. Gas inside the gas spring will be gone naturally even when the frequency of use is low and the spring cannot display the thrust to secure the safety.

If a load equal to or larger than 156N is required when the sewing machine is lifted by strapping front foot section ❶ of the bed with a piece of string as shown in the figure at the left, immediately change the gas spring with JUKI's genuine gas spring (part number: 40100390).



1. Do not strap any section of the machine other than front foot section ❶.
2. The gas spring has a part which is sensitive to the lateral load when the rod section has flaws or the gas spring has fully stretched. Carefully avoid the gas spring being damaged and applied with excessive forces during maintenance and cleaning of the sewing machine.

(7) Replacing the gas spring



DANGER :

Replacement work has to be carried out within the defined range by a service technician who has full knowledge of the machine.

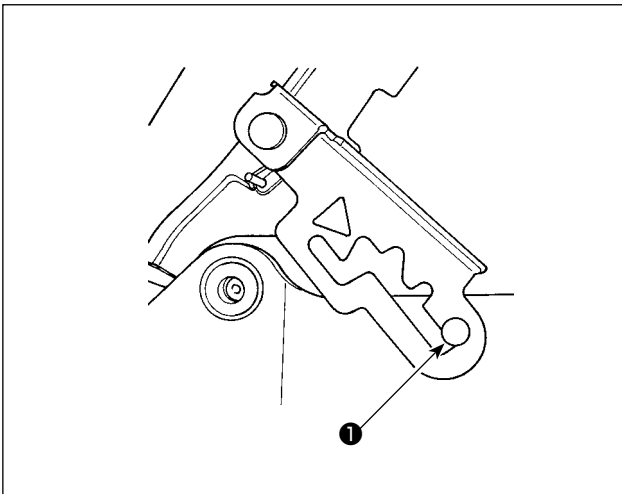

- 1) Lift the sewing machine until the hinge stopper reaches its 4th step and let the hinge stopper lock the sewing machine. Refer to "[3-6. Raising and returning the sewing machine](#)" p. 16 for how to lift the sewing machine.

DANGER :

If the hinge stopper is not locked, the sewing machine can drop to pinch hands, fingers and arms leading to a serious injury.



Make sure that the hinge stopper is locked with support shaft ①.

Never release the lock of the hinge stopper until the gas spring replacement procedure is completed.

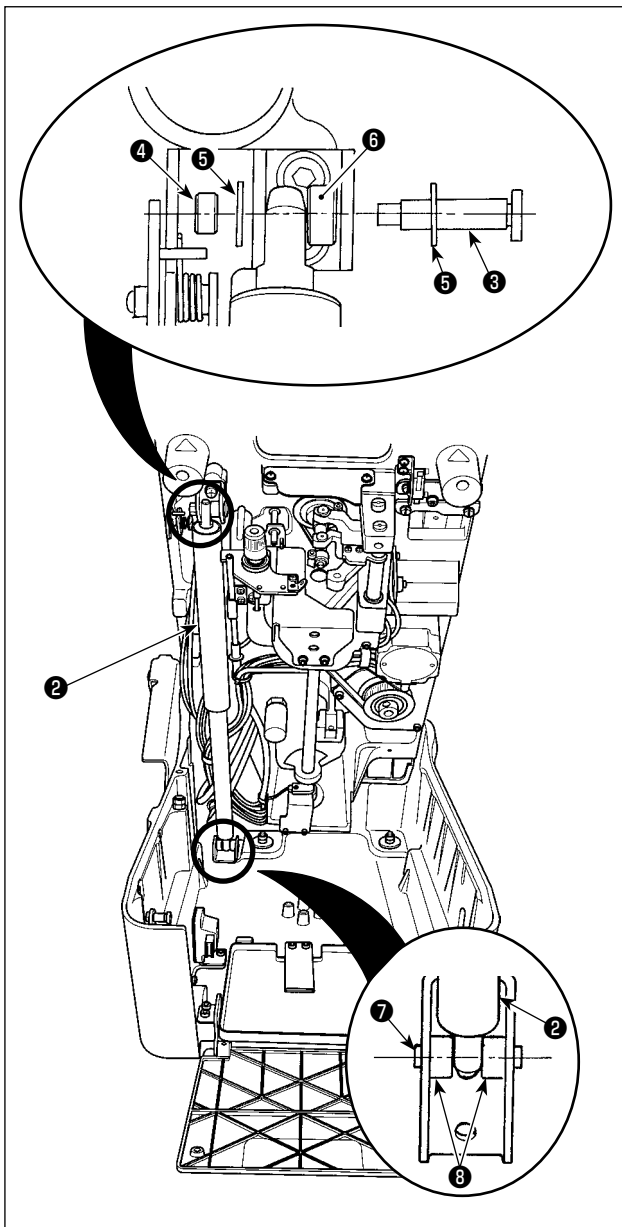

- 2) Check to be sure that gas spring ② does not apply force to the sewing machine. Then, remove nut ④ from fulcrum shaft ③. Remove fulcrum shaft ③, washer ⑤ and thrust collar ⑥.

- 3) Loosen four screws ⑧ which are used to fix fulcrum shaft ⑦ located below gas spring ②. Remove fulcrum shaft ⑦.
- 4) Install new gas spring in the same manner as the previous one. Reverse the removal procedure, assemble the new gas spring.



Check to be sure that the assembled screws and nut are firmly tightened.

- 5) After the completion of assembly, return the sewing machine to its home position. Refer to "[3-6. Raising and returning the sewing machine](#)" p. 16 for how to return the sewing machine to its home position.

11. EXCHANGING GAUGE PARTS AND OPTIONAL

11-1. Throat plate

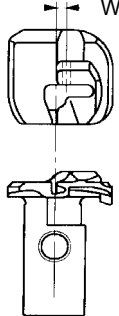
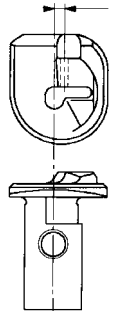
Name of part	A01 * (for narrow needle throwing width)	B01 (for wide needle throwing width)	A00 * (for narrow needle throwing width)	B00 (for wide needle throwing width)
Applicable needle throwing width	2.0 to 3.2mm	2.0 to 4.0mm	2.0 to 3.2mm	2.0 to 4.0mm
Needle size	#90 to #110			
Gimp position W	1.8			
Shape				
Part No.	40115404	40115406	40115403	40115405
Type	For J01 and C01 types Option	For J01 and C01 types Standard	For J00 and C00 types Option	For J00 and C00 types Standard

*** Throat plate for narrow needle throwing width**

Provided that the applicable needle throwing width does not exceed the maximum of 3.2 mm, it is possible to shift the presser foot inward by 0.8 mm with respect to the standard throat plate. As a result, sewing troubles such as a stitch skipping on the machine with a cut-before knife and seam grinning on denim can be prevented effectively.

11-2. Presser set

* The mark in [] parentheses shows the standard equipment for each type.

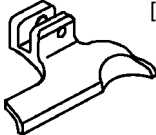
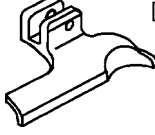
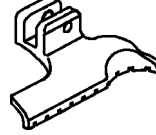
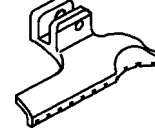
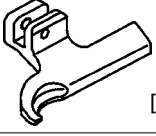
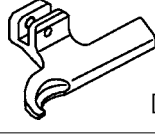
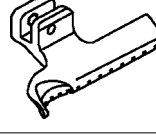
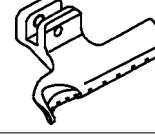
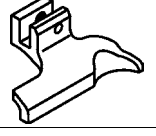
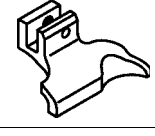
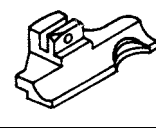
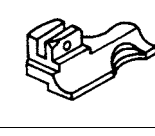
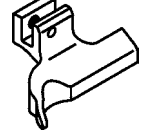
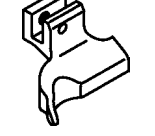
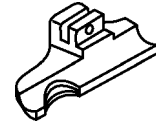
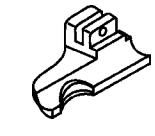
	Name of part	Compensating foot for eyelet buttonhole 34mm	Compensating foot for eyelet buttonhole 38mm	Edge presser for eyelet hole 34mm	Edge presser for eyelet hole 38mm
Presser set (left)	Shape	 [C01]	 [C00]	 [J01]	 [J00]
	Part No.	40115325	40115309	40115241	40115239
Presser set (right)	Shape	 [C01]	 [C00]	 [J01]	 [J00]
	Part No.	40115324	40115316	40115240	40115238
Presser set (left)	Shape				
	Part No.	40035239	40039844	14059604	14059802
Presser set (right)	Shape				
	Part No.	40035238	40039843	14059505	14059703

11-3. Presser holding plate

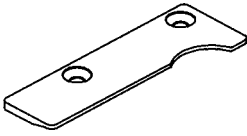
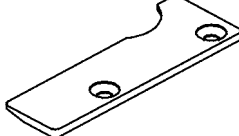
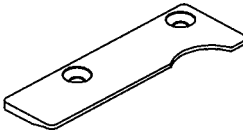
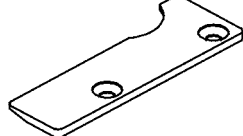
Name of part	Eyelet buttonhole presser holding plate, left	Eyelet buttonhole presser holding plate, right	Eyelet buttonhole presser holding plate, left	Eyelet buttonhole presser holding plate, right
Shape of hole	Eyelet buttonhole		Eyelet buttonhole	
Stitch length	10 to 34		10 to 38	
Shape				
Part No.	40115322	40115323	32027104	32027005
Type	For J01 and C01 types		For J00 and C00 types	

11-4. Cloth cutting knife

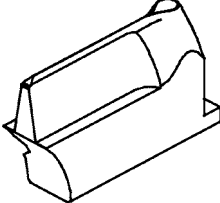
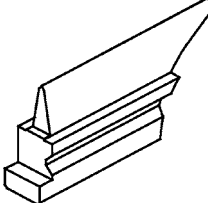
Name of part	For eyelet buttonhole	For decorative buttonhole				
Shape						
		Part No.	X	Y	L	Remarks
Eyelet buttonhole	Provided as standard	40115664	2.8	4.3	26	Optional spacer is used *1
	Only for the sewing machine provided with the needle thread trimmer	40115665	2.8	4.3	38	
		32063604	2.9	4.4	24	
		32063703	2.9	4.4	32	
	Only for the sewing machine provided with the needle thread trimmer	32063802	2.1	3.2	38	
		32063901	2.1	3.2	24	
		32064008	2.1	3.2	32	
		32064107	3.2	5.4	38	
		32064206	3.2	5.4	24	
		32064305	3.2	5.4	32	
Decorative buttonhole	Only for the sewing machine provided with the needle thread trimmer	32066904	2.7	5.1	38	
		14041404	0	0	38	
		32065302	0	0	24	
		32065401	0	0	32	

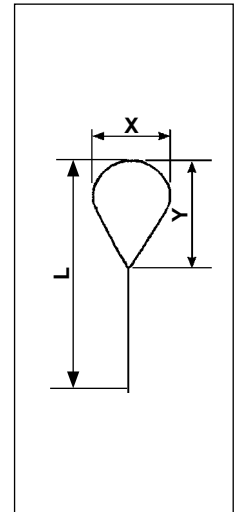

*1 Part number of the optional spacer is 40115728.

Adhere the optional spacer and the cloth trimming knife with each other with their holes aligned so as to prevent the holes are covered.



Optional spacer

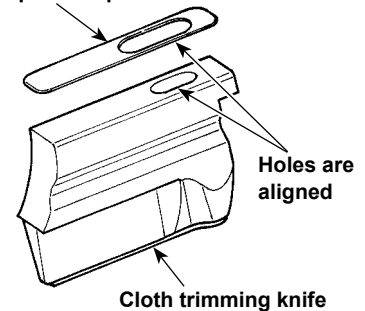

Cloth trimming knife

11-5. Hammer

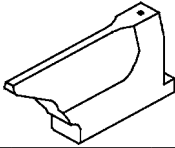
Name of part	For eyelet buttonhole	
Shape		
Size (mm)	Part No.	Remarks
38	40115670	
26	[J accessories] 40115669	
22	[C accessories] 40115668	
20	[J] 40115667	
16	[C] 40115666	
38	32067209	Optional spacer is used *2
36	32067308	
34	32067407	
32	32067506	
30	32067605	
28	32067704	
26	32067803	
24	32067902	
22	32068009	
20	32068108	
18	32068207	
16	32068306	
14	32068405	
12	32068504	
10	32068603	

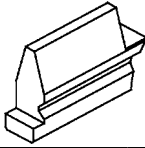
Name of part	For decorative buttonhole	
Shape		
Size (mm)	Part No.	Remarks
38	14042501	Optional spacer is used *2
36	32064404	
34	32064503	
32	14042600	
30	32064602	
28	32064701	
26	14042808	
24	32064800	
22	14042907	
20	32064909	
18	32065005	
16	14043103	
14	32065104	
12	32065203	
10	14043301	

(The mark in [] parentheses shows the standard equipment for each type.)

1. *2 Part number of the optional spacer is 40115639.

Use the optional spacer with adhered on the installing plane of the hammer.

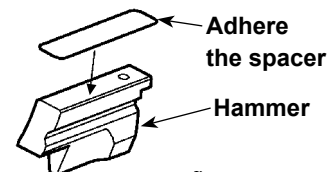

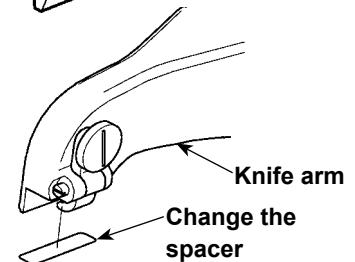

2. In the case the knife height is not correct with the spacer factory-adhered on the knife installing plane of the knife arm, replace the spacer with the one supplied with the unit as an accessory.

Refer to "10-14. (2) Replacing the cloth cutting knife and the hammer" p.108 for the spacer supplied with the unit.

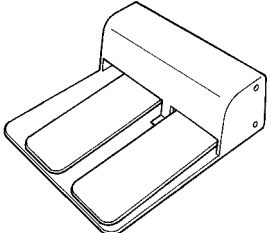

11-6. Others

Name of part	Foot pedal switch (asm.)	Foot pedal switch junction cable (asm.)
Shape and application	 Operation of the sewing machine is performed by foot pedal.	 This is used for connecting the foot pedal switch (asm.).
Part No.	40033831	40114433

12. TROUBLES AND CORRECTIVE MEASURES IN SEWING

Phenomenon	Cause	Corrective measure	Page				
1. Stitch skipping	<ul style="list-style-type: none"> • The needle is bent. There is a scratch on the needle. The needle is incorrectly attached. • Kind of needle is wrong. • The clearance between the needle and the looper is too large. • The clearance between the needle and the needle guard is too large or the needle and the needle guard come in excessive contact with each other. • The clearance between the needle and the looper varies according to the turning angle (0°, 90° and 180°). • Improper adjustment of the timing between the needle and the looper • Improper adjustment of the timing to open/close the spreader. The spreader comes in contact with the needle. • Motion to open/close the spreader is not smooth. • The clearance between the presser foot and the needle entry point is too large. • Thread tension is not proper. • The blade point of looper has worn out. • Improper adjustment of the height of the needle bar. • Loop cannot be scooped since it is not formed. 	<ul style="list-style-type: none"> • Check and replace the needle. • Use DO x 558 needle. • Adjust the clearance at the time of inside needle or outside needle. • Check and adjust the clearance. • Adjust the center of the needle. • Adjust the timing with the stitch bite width used. • Adjust the timing to open/close the spreader by the stitch bite width used. • Remove the cloth waste from the spreader. Replace the spreader with a new one. • Check the clearance and properly adjust it. • Set the thread tension to the proper value. • Correct the looper with oil-stone or the like, or replace it with a new one. • Check the height of the needle bar and properly adjust it. • Check the height of the needle bar and properly adjust it. • Adjust the clearance at the time of inside needle or outside needle with the needle size used. • Adjust the timing to open/close the spreader with the needle size used. • Use the throat plate suitable for the needle. • Decrease the needle thread tension. • Reduce the sewing speed of the sewing machine. • Change the needle to a thicker one. Adjust the stitch base line offset. • Re-set the cut space. 	<ul style="list-style-type: none"> 38 1 100 100 - 95 101 101, 102, 106 78, 104 45, 83 100 98 98 100 101 112 45 71 38 57, 62 				
				• When changing needle size	<ul style="list-style-type: none"> • Improper adjustment of the clearance between the needle and the looper • Improper adjustment of the timing to open/close the spreader. The spreader comes in contact with the needle. • The needle does not fit the kind of throat plate (needle size used). 	<ul style="list-style-type: none"> • Adjust the clearance at the time of inside needle or outside needle with the needle size used. • Adjust the timing to open/close the spreader with the needle size used. 	<ul style="list-style-type: none"> 100 101
				• When kind of thread is affected	<ul style="list-style-type: none"> • Thread which is difficult to make loops is used. (Hard-to-slide thread or the like) 	<ul style="list-style-type: none"> • Decrease the needle thread tension. 	<ul style="list-style-type: none"> 45
				• When sewing heavy-weight materials	<ul style="list-style-type: none"> • The needle is bent at the thick section of the material and stitch skipping occurs. • In case of the cut-before knife, the inside needle is bent at the cutting section and stitch skipping occurs. 	<ul style="list-style-type: none"> • Properly adjust the needle thread drawing amount. 	<ul style="list-style-type: none"> 79
				2. Stitch skipping at the sewing start	<ul style="list-style-type: none"> • The left-hand spreader is installed incorrectly. • The timing of the right-hand looper is too early. • The clearance between the presser foot and the needle entry point is too large. • The looper is bent. There are scratches on the looper. • Length of the needle thread remaining on the needle is too short. • Looper thread clamp/looper thread presser is weak and the looper thread comes off at the start of sewing. 	<ul style="list-style-type: none"> • Check the installing position and adjust it. • Check the timing between the needle and the looper, and adjust it. • Check the clearance and adjust it. • Check the looper and replace it with a new one. • Properly adjust the needle thread drawing amount. • Check the needle clamp pressure. 	<ul style="list-style-type: none"> 101 95 78, 104 95 79 105
				3. Stitch skipping at eyelet section	<ul style="list-style-type: none"> • The clearance between the presser foot and the needle entry point is too large. • The cloth is flopping. • Needle thread loop is too large and falls. As a result, it is not caught by the looper. • Needle thread loop cannot be made. As a result, the looper cannot catch the thread. 	<ul style="list-style-type: none"> • Check the clearance and adjust it properly. • Decrease the sewing speed of eyelet section. Adjust the position of the presser foot. • Adjust the height of the needle bar. Adjust the looper timing. • Adjust the height of the needle bar. Adjust the looper timing. 	<ul style="list-style-type: none"> 78, 104 71 104 98 95 98 95
				4. Seam splitting at the sewing end	<ul style="list-style-type: none"> • The feeding amount of needle thread is insufficient. • The timing of the right-hand looper is too late. • The opening amount of the right-hand spreader is insufficient. • The gimp is too hard. 	<ul style="list-style-type: none"> • Adjust the feeding amount of needle thread. • Check and adjust the timing between the needle and the looper. • Check and adjust the opening amount of the spreader. • Replace the gimp. Check the thread path of gimp. 	<ul style="list-style-type: none"> 79 95 101 41, 80
				5. Needle thread breakage	<ul style="list-style-type: none"> • The needle thread tension is too high. 	<ul style="list-style-type: none"> • Adjust the sewing conditions to obtain an appropriate thread tension. 	<ul style="list-style-type: none"> 45, 83
					<ul style="list-style-type: none"> • The needle comes in contact with the blade point of the looper. • The thread paths in the needle, loopers, spreaders, throat plate, etc. have become worn out or contain scratches. • The thread is too thick or too thin for the needle. • There are scratches in the needle hole or needle slot. 	<ul style="list-style-type: none"> • Check and adjust the clearance. • Check and replace the respective parts. • Replace the needle with a proper one. • Check and replace the needle. 	<ul style="list-style-type: none"> 100 38, 100, 101 38 38

Phenomenon	Cause	Corrective measure	Page
6. Looper thread breakage	<ul style="list-style-type: none"> The looper thread tension is too high. The installing position of the left-hand spreader is incorrect. Refer to "5. Needle thread breakage" for details on other causes and corrective measures 	<ul style="list-style-type: none"> Adjust the sewing conditions to obtain an appropriate thread tension. Check and adjust the installing position. 	45, 83
			101
7. Needle breakage	<ul style="list-style-type: none"> The needle interferes with looper, spreader, etc. The needle comes in contact with the presser foot. The clearance between the needle and the looper varies according to the turning angle (0°, 90° and 180°). The clearance between the needle and the needle guard is too large or the needle and the needle guard come in excessive contact with each other. The height of the needle bar has been improperly adjusted. Needle thread is depressed by the presser foot at the start of sewing. 	<ul style="list-style-type: none"> Adjust the clearance between the looper and the needle properly. Adjust the timing to open/close the spreaders properly. Check and adjust the clearance. Adjust the center of the needle. Check and adjust the clearance. Check and adjust the height of the needle bar. Properly adjust the needle thread drawing amount. 	100 to 102
			78, 104
			-
			100
8. Stitches at the straight section of the buttonhole are not uniform.	<ul style="list-style-type: none"> The left- and right-hand sewing pitches at the straight section are different from each other. The left- and right-hand positions at the straight section are different from each other. Stitches which should be parallel are slant. 	<ul style="list-style-type: none"> Compensate the length by lengthwise compensation of left parallel section of the data compensation. Compensate the position by lengthwise compensation of left eyelet of the data compensation. Compensate the inclination by turning compensation of parallel section of the data compensation. 	56
			61
			59
9. The left- and right-hand sides of the seam at the straight section of the buttonhole are not uniform.	<ul style="list-style-type: none"> The left- and right-hand side cloth opening amounts are not equal. Improper adjustment of the knife dropping position There is shrinkage of cloth by sewing or step difference between left- and right-hand sides of cloth. 	<ul style="list-style-type: none"> Adjust so that the left- and right-hand side cloth opening amounts are equal. Check and adjust the knife dropping position. 	78
			104
10. The shape of the eyelet is deformed.	<ul style="list-style-type: none"> The seam is tilted. The cloth is deformed by the seam. Improper adjustment of the knife dropping position The cloth at eyelet section is flopping. The gimp is moved to the inside needle side. 	<ul style="list-style-type: none"> Set the turning compensation/parallel section turning compensation. Set the eyelet crosswise compensation/lengthwise compensation. Check and adjust the knife dropping position. Adjust the position of the presser foot. Replace the throat plate with the optional one. 	59
			78
11. The seam is cut by the cut-after knife.	<ul style="list-style-type: none"> The clearance between the cloth cutting knife and the needle is too small. Improper adjustment of the knife dropping position There is shrinkage of cloth by sewing or step difference between left- and right-hand sides of cloth. 	<ul style="list-style-type: none"> Check the cut (eyelet) space and re-set it. Check and adjust the knife dropping position. Individually set the left- and right-hand sides of cut space. 	104
			55, 57 to 62
			104
12. Needle thread cannot be trimmed.	<ul style="list-style-type: none"> The needle thread trimming knife is dull. The stroke of the needle thread trimming knife is incorrect. The needle thread trimming knife does not catch needle thread. The last stitch has skipped. Installing position of the moving blade is incorrect. 	<ul style="list-style-type: none"> Grind the knife or replace it with a new one. Check and adjust the stroke. Adjust the installing position (clearance between needle and knife) of the knife. Refer to "1. Stitch skipping". Check and adjust the moving blade and the thread separating position. 	83, 104, 110
			104
			104
			-
13. Looper thread cannot be trimmed.	<ul style="list-style-type: none"> The knife is dull. The knife position is wrong. 	<ul style="list-style-type: none"> Grind the knife or replace it with a new one. Properly adjust the knife position. 	109
			95
14. The cloth cannot be cut sharply.	<ul style="list-style-type: none"> Doubling the planes of the knife and the hammer is incorrect. The knife is dull. The knife pressure is inadequate. Chip has collected. Knife pressure is too high and the knife blade has broken. 	<ul style="list-style-type: none"> Correct the surface of the hammer with oil stone or the like. Grind the knife or replace it with a new one. Re-set the knife pressure. Remove the chip. Set proper knife pressure to each sewing product after replacing the knife. 	107
			108
			75
			108
			75, 108
15. Breakage of looper/spreader	<ul style="list-style-type: none"> The clearance between the needle and the looper varies according to the angle (0°, 90° and 180°). The clearance between the needle and the needle guard is too large or the needle and the needle guard come in excessive contact with each other. 	<ul style="list-style-type: none"> Adjust the center of the needle. Check and adjust the clearance. 	-
			100

13. MEMORY SWITCH

13-1. Operating procedure

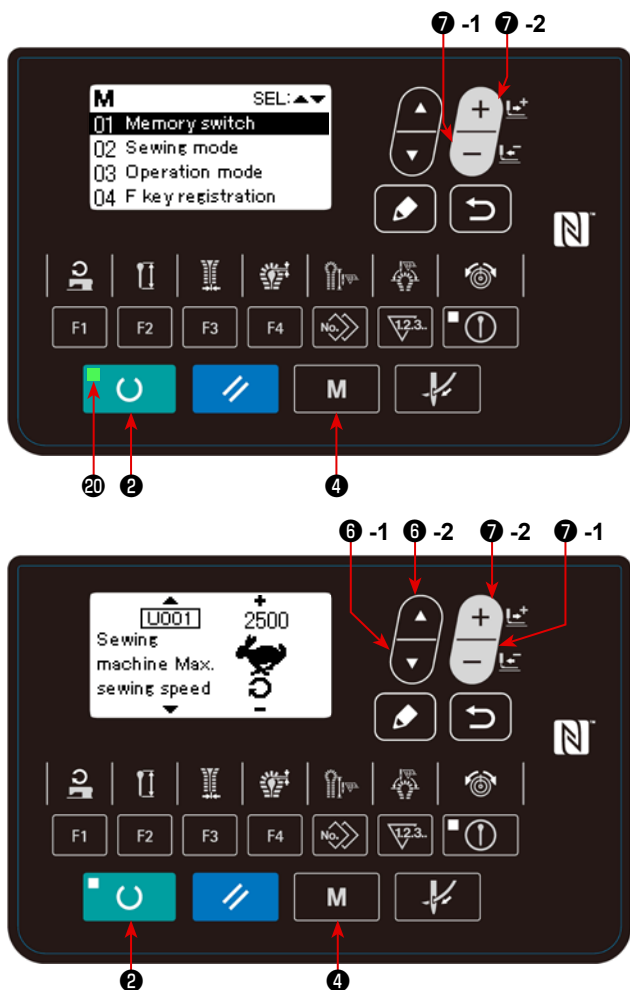

1) Set the mode to input mode

Under the input mode where SET READY LED 20 goes out, change to the memory switch data is enabled.

If the current mode is the sewing mode, press READY key 20 to change over the mode to the input mode.

2) Call memory switch data edit screen

When MODE key M 4 is pressed, the mode screen (operator level) is displayed.

On this screen, select the memory switch data (level 1).

When MODE key M 4 is held pressed for three seconds, the mode screen (maintenance personnel level) is displayed.

On this screen, the memory switch data (level 2) can be selected.

3) Select memory switch data to change

Press ITEM SELECT key 6 and select the data item which you desire to change.

4) Change data

There are one data item to change the numerical value and the other data item to select the pictograph in the memory switch data.

No. such as U001 is attached to the data item to change the numerical value. Set value can be changed by increasing/decreasing the value with

DATA CHANGE key 7.

No. such as S001 is attached to the data item to select the pictograph. Pictograph can be selected





























with DATA CHANGE key 7 is attached to





























the data item to select the pictograph. Pictograph can be selected with DATA CHANGE key.

→ For the details of memory switch data, refer to





















"13-2. Memory switch list" p. 118.























13-2. Memory switch list













No.	Function	Setting range	Setting unit	Initial value
U001	Max. sewing speed Max. sewing speed is set	 400 to 2,500	100 sti/min	2,500
U002	Soft-start speed setting 1st stitch (inside needle → outside needle) Limited speed at the sewing start of the sewing machine is set. From inside needle to outside needle of 1st stitch	 400 to 1,200	100 sti/min	600
U003	Soft-start speed setting 1st stitch (outside needle → inside needle) Limited speed at the sewing start of the sewing machine is set. From outside needle to inside needle of 1st stitch	 400 to 2,500	100 sti/min	600
U004	Soft-start speed setting 2nd stitch (inside needle → outside needle) Limited speed at the sewing start of the sewing machine is set. From inside needle to outside needle of 2nd stitch	 400 to 2,500	100 sti/min	600
U005	Soft-start speed setting 2nd stitch (outside needle → inside needle) Limited speed at the sewing start of the sewing machine is set. From outside needle to inside needle of 2nd stitch	 400 to 2,500	100 sti/min	600
U006	Soft-start speed setting 3rd stitch (inside needle → outside needle) Limited speed at the sewing start of the sewing machine is set. From inside needle to outside needle of 3rd stitch	 400 to 2,500	100 sti/min	600
U007	Soft-start speed setting 3rd stitch (outside needle → inside needle) Limited speed at the sewing start of the sewing machine is set. From outside needle to inside needle of 3rd stitch	 400 to 2,500	100 sti/min	600
U008	Needle thread tension at the time of thread trimming Needle thread tension at the time of trimming the needle thread is set.	 0 to 200	1	0
U010	Needle thread tension at the time of stopping Needle thread tension at the time of trimming the looper thread or stopping the sewing machine is set.	 0 to 200	1	60
U012	Set position selection Position of presser when setting cloth is selected.  0 : Origin position  1 : Front position  2 : Origin when the cut-before knife is used; Sewing start position when the cut-after knife is used/knife is not installed  3 : Front side when the cut-before knife is used; sewing start position when the cut-after knife is used/knife is not installed (Position is set at No. = 23.)	-	1	
U014	Selection of starting when production counter is "0" Whether prohibiting starting at count value "0" when production counter is set to DOWN counter is selected.  0 : Starting permitted even when production counter value is "0"  1 : Starting prohibited when production counter value is "0"	-	-	
U015	Start switch One-touch startup selection Enable/disable of the startup only by means of the start switch is selected.  0: Presser foot is brought to the lower position by means of the presser foot switch and the sewing machine is started by means of the start switch  1: Presser foot is brought to the lower position and the sewing machine is started by means of the start switch (The presser foot switch is also enabled.)	-	-	
U016	Pattern data setting prohibition Whether or not the pattern data setting is prohibited is selected.  0: Setting is enabled  1: Setting is prohibited (Thread tension can be set)	-	-	
U017	Thread tension compensation setting prohibition Whether or not the thread tension compensation value is set under the ready state is selected.  0 : Setting is enabled  1 : Setting is prohibited	-	-	
U018	Pattern data deletion prohibition Whether or not the pattern data deletion is prohibited is selected.  0 : Deletion is enabled  1 : Deletion is prohibited	-	-	

No.	Function	Setting range	Setting unit	Initial value	
U019	Looper thread trimming operation selection (Only for the general thread trimming type machine) Whether or not the looper thread trimming operation is carried out is selected.  0 : Not performed  1 : Performed	-	-		
U020	Presser foot lowering at the time of returning to the setting position Whether or not the feed base returns to the setting position with the presser foot lowered after sewing is completed.  0 : The feed base returns to the setting position with the presser foot lifted.  1 : The feed base returns to the setting position with the presser foot lowered, and the presser foot goes up at the setting position  2 : The feed base returns to the setting position with the presser foot lowered, and the presser foot is brought to the upper position at the setting position by means of the presser foot switch.	-	-		
U021	After-cut knife temporary stop selection Whether or not the machine is stopped before the after-cut knife operates and the cloth cutting knife is operated by means of the start switch is selected  0 : Normal operation  1 : The sewing machine automatically stops before the after-cut knife operates, and the knife is operated by means of the start switch.	-	-		
U022	Cloth opening mechanism selection for straight bar pattern Whether or not the sewing of a pattern including the straight bar is performed with the cloth opening mechanism held opened.  0 : Normal operation  1 : Material is placed on the sewing machine with the cloth opening mechanism held opened.	-	-		
U023	Front setting position Position relative to the origin is set when "front position" is selected for No. 12 is set.		0 to 54	1mm	22
U024	Needle thread clamp unit operation selection (When the needle thread clamp unit is selected as an option) Selection of whether the needle thread clamp unit is operated  0 : Not operated  1 : Operated (needle thread is clamped with the feed stopped)  2 : Operated (needle thread is clamped without the feed stopped)	-	-		
U025	Number of stitches to lift needle thread clamp unit (When the needle thread clamp unit is selected as an option) The number of stitch at which the needle thread clamp unit goes up is set.		0 to 20	1 stitch	14
U026	Travel amount of needle thread clamp unit (When the needle thread clamp unit is selected as an option) The distance (unit : mm) by which the needle thread clamp unit travels from the end of sewing, before the unit is closed is set.		0 to 40	1mm	10
U030	LED lamp dimming setting LED lamp brightness is set with percentage (%)		0 to 100	5%	100
U031	Selection of needle thread clamp unit opening amount (When the needle thread clamp unit is selected as an option)  0 : Goes up with opened when going up at the start of sewing  1 : Goes up with closed when going up at the start of sewing	-	-		
U032	Needle thread clamp unit lowering timing at the end of sewing (When the needle thread clamp unit is selected as an option) The number of needle entry at which the needle thread clamp unit comes down at the end of sewing is set.		0 to 4	1 Needle entry	3
U033	Needle thread tension when the needle thread clamp trims the needle thread. (When the needle thread clamp unit is selected as an option) The needle thread tension value when the needle thread clamp operates to trim the needle thread is set.		0 to 200	1	2
U034	Needle thread tension when the needle thread clamp draws the needle thread (When the needle thread clamp unit is selected as an option) The needle thread tension value of the needle thread clamp unit when it operates to draw the needle thread after it has been trimmed is set.		0 to 200	1	150
U035	Selection of the cloth opener in the case of sewing radial stitch eyelets This item number is used for selecting whether or not the sewing pattern with radial stitch eyelets is sewn while keeping the cloth opener held opened.  0: Normal  1: Cloth opener is always opened during the sewing of radial stitch eyelets	-	1		

14. ERROR LIST

No.		Description	How to reset
E007		Main shaft motor-lock When large needle resistance sewing product is sewn.	Turn OFF the power.
E008		Machine head memory error In the case data on the machine head memory has broken. (Note 4)	Model type, memory switch data and standard patterns are initialized after pressing the reset key.
E011		External media not inserted External media is not inserted.	Possible to recover by reset.
E012		Read error Data read from external media cannot be performed.	Possible to recover by reset.
E013		Write error Data write from external media cannot be performed.	Possible to recover by reset.
E014		Write protect External media is in the write prohibition state.	Possible to recover by reset.
E015		Format error Formatting of external media cannot be performed.	Possible to recover by reset.
E016		External media capacity over Capacity of external media is short.	Possible to recover by reset.
E022		File No. error There is no designated file in the external media.	Possible to recover by reset.
E030		Needle bar upper position failure When needle does not stop at UP position even with needle UP operation at the time of starting sewing machine.	Possible to recover by reset.
E031		Air pressure drop Air pressure is dropped.	Supply air and reset the sewing machine. Then, the operation is enabled again.
E050		Stop switch When stop switch is pressed during machine running.	Possible to recover by reset.
E060		Backup memory error When backup data such as pattern No. or the like has not been stored in memory.	Backup data will be initialized after pressing the RESET key.
E061		Memory switch data error When memory switch data is broken or revision is old.	Turn OFF the power.
E204		Connection alert for the USB thumb drive which is used for sewing When sewing has been carried out by 10 or more times with the USB thumb drive inserted in the USB port. (Warning is given, in the case it is determined that a continuous sewing pattern is being sewn after the sewing machine has performed sewing by 10 times continuously, when the sewing machine completes sewing of the pattern.)	Possible to re-sewing after pressing reset key.
E302		Machine head tilt or hook cover opening In the case the machine head tilt detection signal is ON.	Possible to recover by reset.
E303		Z phase sensor error of main shaft motor Z phase sensor of sewing machine motorencoder is abnormal.	Turn OFF the power.
E396		Looper thread cutting knife operation error In the case the looper thread trimming knife return sensor stays on when the looper thread trimming is carried out.	Remove the cause of error and press the RESET key.
E397		Cloth cutting knife intermediate position error In the case the cloth cutting knife intermediate position sensor does not turn on when the cloth cutting knife operates.	Remove the cause of error and press the RESET key.
E398		Cloth cutting knife upper position error In the case the cloth cutting knife upper position sensor stays off when the sewing machine operates and the cloth cutting knife operates.	Remove the cause of error and press the RESET key.
E399		Looper thread trimming knife return error When the sewing machine is in operation, when the bobbin thread trimmer is in operation or when the bobbin thread trimmer return sensor is in the off state.	Remove the cause of error and press the RESET key.
E430	* Count-up screen display (see page 48)	Count-up error	Possible to re-sewing after pressing reset key.

No.		Description	How to reset
E494		The number of stitches is exceeded In the case the number of stitches exceeds the permissible value at the time of setting data.	Change the data after pressing the RESET key.
E495		Basting number error The pattern with the number specified with "U090 Basting pattern number" does not exit.	Change the data after pressing the RESET key.
E496		Thread tension setting range error Outside of setting range error at the time of thread tension setting. (Note 1)	Change the thread tension after pressing the RESET key.
E497		Data setting sewing length error Sewing length is over the sewing possible area at the time of data setting. (Note 2)	Change the data after pressing the RESET key.
E498		Data setting range error Outside of setting range error at the time of data setting. (Note 3)	Change the data after pressing the RESET key.
E499		Pattern type error The model type does not match the pattern type. (Note 4)	Pattern is changed and/or pattern is deleted after the reset key is pressed.
E703		Panel is connected to the machine other than supposed. (Machine type error) When machine type code of system is improper in case of initial communication.	Turn OFF the power.
E704		Nonagreement of system version When version of system software is improper in case of initial communication.	Turn OFF the power.
E730		Main shaft motor encoder defectiveness or phase-out When encoder of sewing machine motor is abnormal.	Turn OFF the power.
E731		Main motor hole sensor defectiveness or position sensor defectiveness When hole sensor or position sensor of sewing machine motor is defective.	Turn OFF the power.
E733		Reverse rotation of main shaft motor When sewing machine motor rotates in reverse direction.	Turn OFF the power.
E801		Phase-lack of power When phase-lack of input power occurs.	Turn OFF the power.
E802		Power instantaneous cut detection When input power is instantaneously OFF.	Turn OFF the power.
E811		Over voltage In the case the input power source voltage/current is equal to or more than the specified value	Turn OFF the power.
E813		Low voltage In the case the input power source voltage/current is equal to or less than the specified value	Turn OFF the power.
E820		24 VDC fuse has blown out When the SDC fuse has blown out.	Turn OFF the power.
E901		Abnormality of main shaft motor IPM When IPM of servo control p.c.b. is abnormal.	Turn OFF the power.
E902		Overcurrent of main shaft motor When current flows excessively to sewing machine motor.	Turn OFF the power.
E903		Abnormality of stepping motor power In the case the stepping motor power of the servo-control PCB is out of the range of the specified values	Turn OFF the power.
E904		Abnormality of solenoid power In the case the solenoid power of the servo-control PCB is out of the range of the specified values	Turn OFF the power.
E905		Abnormality of temperature of heat sink for servo control p.c.b. When temperature of heat sink of servo control p.c.b. is 85°C or more.	Turn OFF the power.
E907		Needle rocking motor origin retrieval error When origin sensor signal is not inputted at the time of origin retrieval motion.	Turn OFF the power.
E908		Y feed motor origin retrieval error When origin sensor signal is not inputted at the time of origin retrieval motion.	Turn OFF the power.

No.		Description	How to reset
E914		Feed trouble error Timing lag between feed and main shaft has occurred.	Turn OFF the power.
E915		Abnormality of communication between operation panel and main CPU When abnormality occurs in communication.	Turn OFF the power.
E916		Abnormality of communication between main CPU and main shaft CPU When abnormality occurs in communication.	Turn OFF the power.
E918		Abnormality of temperature of heat sink for main control p.c.b. When temperature of heat sink of main control p.c.b. is 85°C or more.	Turn OFF the power.
E926		X motor displacement error X feed motor is out of position.	Turn OFF the power.
E927		Y motor displacement error Y feed motor is out of position.	Turn OFF the power.
E931		X motor overload error The load applied to the X feed motor is excessive.	Turn OFF the power.
E932		Y motor overload error The load applied to the Y feed motor is excessive.	Turn OFF the power.
E946		Defectiveness of writing to EEP-ROM of head relay p.c.b. When data writing to EEP-ROM is not performed.	Turn OFF the power.
E997		Rotating motor overload error In the case the rotating motor is overloaded	Turn OFF the power.
E998		Rotating motor out-of-position error In the case the rotating motor is out of position	Turn OFF the power.
E999		Rotating motor origin sensor error In the case the rotation origin sensor does not change at the time of origin retrieval	Turn OFF the power.

Note 1 : Set the thread tension within the range of $0 \leq \text{thread tension} + \text{compensation value of thread tension} \leq 200$.

Note 2 : $L = \text{cut length} + \text{taper bar length} + \text{Crosswise compensation of left eyelet} + \text{Crosswise compensation of left parallel section} + \text{compensation of number of stitches at sewing end}$
Set the above length within the range described in the table below.

Type	Thread trimming type	J type, C type
MEB3900J00/MEB3900C00	Needle thread trimming type	$10 \leq L \leq 38$ (mm)
MEB3900J01/MEB3900C01	General thread trimming type	$10 \leq L \leq 34$ (mm)

Note 3 : Set the data within the range below.

Sewing speed – (minus) eyelet reduced speed ≥ 400

Number of stitches of slant taper bar \leq number of stitches of taper bar























Compensation of number of stitches of right taper bar \leq number of stitches of taper bar



















$-14 \leq \text{compensation of turning} + \text{compensation of turning at parallel section} \leq 14$

$-1.2 \leq \text{cut space} + \text{compensation of left cut space} \leq 1.2$











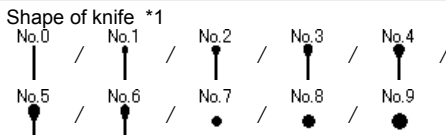















Note 4 : If you replace the MAIN PWB and/or INT PWB, carry out the model setting. At this time, patterns of pattern numbers 1 to 87 are not deleted. Refer to the Engineer's Manual for the model setting.



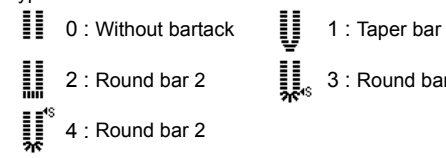



























15. STANDARD PATTERN LIST

Data No.	Setting item	J type Pattern No.											C type Pattern No.												
		88	89	90	91	92	93	94	95	96	97	98	99	88	89	90	91	92	93	94	95	96	97	98	99
	Shape																								
S001	Knife No.	7		3					3					7		3					3				
S002	Cut length	22		21	20	22	21	22	27	26	28	27	28	22		17	16	18	17	18	23	22	24	23	24
S003	Cut-before/cut-after knife	1	2	2	1	2		2	1	2		1	2	2	1	2		2	1	2		2	1	2	
S004	Number of stitches of parallel	18		17	16	18	17	18	23	22	24	23	24	18		13	12	14	13	14	19	18	20	19	20
S005	Number of stitches of eyelet	9		9					9					9		9					9				
S006	Cut space	0	3	0.3	0.0	0.3		0.3	0.0	0.3		0	3	0.3	0.0	0.3		0.3	0.0	0.3		0	3		
S007	Eyelet space	0	4	0.4	0.0	0.4		0.4	0.0	0.4		0	4	0.4	0.0	0.4		0.4	0.0	0.4		0	4		
S008	Compensation of knife position	0		0.0					0.0					0		0.0					0.0				
S009	Compensation of number of stitches at sewing end	0		0					0					0		0					0				
S010	Compensation of turning	0		0					0					0		0					0				
S011	Compensation of turning at parallel section	0		0					0					0		0					0				
S012	Lengthwise compensation of eyelet	0		0.0					0.0					0		0.0					0.0				
S013	Crosswise compensation of eyelet	0		0.0					0.0					0		0.0					0.0				
S014	Crosswise compensation of left eyelet	0		0.0					0.0					0		0.0					0.0				
S015	Crosswise compensation of left parallel	0		0.0					0.0					0		0.0					0.0				
S016	Left cut-space compensation	0		0.0					0.0					0		0.0					0.0				
S017	Setting of stitch bite width of right bottom of eyelet	25		2.5					2.5					25		2.5					2.5				
S018	Setting of stitch bite width of left bottom of eyelet	25		2.5					2.5					25		2.5					2.5				
S019	Setting of stitch bite width	25		2.5					2.5					25		2.5					2.5				
S020	Type of bartack	0	1	2	3	0	1	2	3	0	0	1	2	3	0	1	2	3	0	0	1	2	3	0	
S021	Length of taper bar	6		6					6					6		6					6				
S022	Number of stitches of taper bar	5		5					5					5		5					5				
S023	Taper bar offset	12		1.2					1.2					12		1.2					1.2				
S024	Number of stitches of slant taper bar	3		3					3					3		3					3				
S025	Compensation of number of stitches of right taper bar	0		0					0					0		0					0				
S026	Straight bar length	50		5.0					5.0					50		5.0					5.0				
S027	Number of stitches of straight bar	6		6					6					6		6					6				
S028	Overlapping amount of straight bar	15		1.5					1.5					15		1.5					1.5				
S029	Needle throwing width of straight bar	25		2.5					2.5					25		2.5					2.5				
S030	Number of stitches of round bar	5		5					5					5		5					5				
S031	Number of overlapping stitches of round bar 2	2		2					2					2		2					2				
S032	Needle throwing width for round bartack	25		2.5					2.5					25		2.5					2.5				
S033	Needle throwing width at the top of eyelet	25		2.5					2.5					25		2.5					2.5				
S034	Speed reduction of straight bar/round bar	0		0					0					0		0					0				
S035	Sewing speed	1800		1800					1800					1800		1800					1800				
S036	Reduced speed of eyelet	0		0					0					0		0					0				
S037	Soft-start	2		2					2					2		2					2				

Data No.	Setting item	J type Pattern No.											C type Pattern No.											
		88	89	90	91	92	93	94	95	96	97	98	99	88	89	90	91	92	93	94	95	96	97	98
	Shape																							
S038	Number of stitches of the sewing start of thread tension	1		1				1					1		1				1					
S039	Number of stitches of the sewing end of thread tension	1		1				1					1		1				1					
S040	Needle thread tension	80		80				80					80		80				80					
S041	Compensation of needle thread tension at right parallel section	0		0				0					0		0				0					
S042	Compensation of needle thread tension at left parallel section	0		0				0					0		0				0					
S043	Compensation of needle thread tension at top of eyelet	0		0				0					0		0				0					
S044	Compensation of needle thread tension at right bottom of eyelet	0		0				0					0		0				0					
S045	Compensation of needle thread tension at left bottom of eyelet	0		0				0					0		0				0					
S046	Compensation of needle thread tension bartack, right	0		0				0					0		0				0					
S047	Compensation of needle thread tension bartack, left	0		0				0					0		0				0					
S048	Compensation of needle thread tension bartack, right 2	0		0				0					0		0				0					
S049	Compensation of needle thread tension bartack, left 2	0		0				0					0		0				0					
S050	Compensation of needle thread tension at sewing start	0		0				0					0		0				0					
S051	Compensation of needle thread tension at sewing end	0		0				0					0		0				0					
S052	Compensation of needle thread tension at the time of thread trimming	0		0				0					0		0				0					
S053	Compensation of needle thread tension at the time of stop	0		0				0					0		0				0					
S054	(When the needle thread clamp unit is selected as an option) Compensation of needle thread tension for drawing needle thread clamped by the needle thread clamp unit	0		0				0					0		0				0					
S090	Basting pattern number	0		0				0					0		0				0					
S091	Cloth opener operation is prohibited during basting	0		0				0					0		0				0					
S092	Number of stitches for sewing a radial stitch eyelet	21		21				21					21		21				21					
S093	Overlap stitching angle for the radial stitch eyelet	18		18				18					18		18				18					
S094	Radial stitch eyelet diameter	30	34	34	30	34		34	30	34		30	34	34	30	34		34	30	34		30	34	
	Knife guard size	20mm				26mm				16mm				22mm										

16. SEWING DATA ENTRY SHEET

No.	Setting item	Description	Setting range	Unit
S001	Knife No.	Shape of knife *1 	-	-
S002	Cut length	Length of cloth cutting knife 	*2	1mm
S003	Cut-before/cut-after knife	Operation of cloth cutting knife  0 : Without knife  1 : Cut-before knife  2 : Cut-after knife	0 to 2	-
S004	Number of stitches of parallel	Number of stitches from parallel section to bottom of eyelet 	3 to 100 stitch	1 stitch
S005	Number of stitches of eyelet	Number of stitches of top of eyelet 	4 to 20 stitch	1 stitch
S006	Cut space	Clearance of knife groove of parallel section 	-1.2 to 1.2mm	0.1mm
S007	Eyelet space	Clearance of knife groove of eyelet 	-1.2 to 1.2mm	0.1mm
S008	Compensation of knife position	Longitudinal compensation of whole needle entry 	-0.7 to 0.7mm	0.1mm
S009	Compensation of number of stitches at sewing end	Number of stitches to increase length at sewing end 	-1 to 6 stitch	1 stitch
S010	Compensation of turning	Compensation of turning at parallel section and eyelet section 	-14 to 14	1
S011	Compensation of turning at parallel section	Compensation of turning of parallel section and bottom of eyelet 	-14 to 14	1
S012	Lengthwise compensation of eyelet	Crosswise compensation of eyelet 	-0.6 to 0.6mm	0.1mm
S013	Crosswise compensation of eyelet	Lengthwise compensation of top of eyelet 	-0.2 to 0.6mm	0.1mm
S014	Crosswise compensation of left eyelet	Lengthwise compensation of left side of top of eyelet 	-0.2 to 0.6mm	0.1mm
S015	Crosswise compensation of left parallel	Compensation of length from left side of bottom of eyelet to left side of parallel section 	-0.6 to 0.6mm	0.1mm
S016	Left cut-space compensation	Compensation of the clearance in the left side knife slit at the parallel section 	-2.4 to 2.4mm	0.1mm
S017	Setting of stitch bite width of right bottom of eyelet	Setting of stitch bite width of right side of bottom of eyelet 	2.5±1.0mm	0.1mm
S018	Setting of stitch bite width of left bottom of eyelet	Setting of stitch bite width of left side of bottom of eyelet 	2.5±1.0mm	0.1mm
S019	Setting of stitch bite width	Setting of stitch bite width of parallel section and taper bar 	2.5±1.0mm	0.1mm
S020	Type of bartack	Type of bartack 	-	-
S021	Length of taper bar	Length of taper bar 	0.3 to 15mm	1mm
S022	Number of stitches of taper bar	Number of stitches of taper bar *3 	2 to 30 stitch	1 stitch
S023	Taper bar offset	Overlapping amount of left/right taper bars 	0.5 to 2.0mm	0.1mm
S024	Number of stitches of slant taper bar	Number of stitches of slant section from taper bar to parallel section 	2 to 30 stitch	1 stitch
S025	Compensation of number of stitches of right taper bar	Number of stitches of compensation of right side of taper bar 	-30 to 0 stitch	1 stitch
S026	Straight bar length	Length of the straight bar 	2.0 to 10.0mm	0.1mm

No.	Setting item	Description	Setting range	Unit
S027	Number of stitches of straight bar	Number of stitches of the straight bar *3 	2 to 10 stitch	1 stitch
S028	Overlapping amount of straight bar	Amount of overlap between the straight bar and the parallel section 	0.0 to 2.0mm	0.1mm
S029	Needle throwing width of straight bar	Needle throwing width of the straight bar 	1.5 to 3.5mm	0.1mm
S030	Number of stitches of round bar	Number of stitches of round bar 	4 to 20 stitch	1 stitch
S031	Number of overlapping stitches of round bar 2	Number of stitches that overlap at the beginning and end of the round bar 2 	0 to 4 stitch	1 stitch
S032	Needle throwing width for round bartack	Setting the needle throwing width at the right side of the round bar is set 	2.5±1.0mm	0.1mm
S033	Needle throwing width at the top of eyelet	Setting the needle throwing width at the upper section of eyelet is set 	2.5±1.0mm	0.1mm
S034	Speed reduction of straight bar/round bar	Reduced speed for the sewing speed of the straight bar and round bar 	-600 to 0 sti/min	100 sti/min
S035	Sewing speed	Sewing speed 	400 to 2500 sti/min	100 sti/min
S036	Reduced speed of eyelet	Reduced speed in terms of sewing speed of eyelet 	-600 to 0 sti/min	100 sti/min
S037	Soft-start	Number of times of needle entries of soft-start at sewing start 	0 to 6 rotations	1 rotation
S038	Number of stitches of the sewing start of thread tension	Number of stitches of thread tension compensation at sewing start 	0 to 3 stitch	1 stitch
S039	Number of stitches of the sewing end of thread tension	Number of stitches of thread tension compensation at sewing end 	0 to 3 stitch	1 stitch
S040	Needle thread tension	Needle thread tension value 	0 to 200	1
S041	Compensation of needle thread tension at right parallel section	Compensation value of needle thread tension at right side of parallel section 	*4	1
S042	Compensation of needle thread tension at left parallel section	Compensation value of needle thread tension at left side of parallel section 	*4	1
S043	Compensation of needle thread tension at top of eyelet	Compensation value of thread tension at top of eyelet 	*4	1
S044	Compensation of needle thread tension at right bottom of eyelet	Compensation value of needle thread tension at right side of bottom of eyelet 	*4	1
S045	Compensation of needle thread tension at left bottom of eyelet	Compensation value of needle thread tension at left side of bottom of eyelet 	*4	1
S046	Compensation of needle thread tension bartack, right	Needle thread tension compensation value of the right side of bartack 	*4	1
S047	Compensation of needle thread tension bartack, left	Needle thread tension compensation value of the left side of bartack 	*4	1
S048	Compensation of needle thread tension bartack, right 2	Needle thread tension compensation value of the right side 2 of bartack 	*4	1
S049	Compensation of needle thread tension bartack, left 2	Needle thread tension compensation value of the left side 2 of bartack 	*4	1
S050	Compensation of needle thread tension at sewing start	Compensation value of needle thread tension at sewing start 	*4	1
S051	Compensation of needle thread tension at sewing end	Compensation value of needle thread tension at sewing end 	*4	1
S052	Compensation of needle thread tension at the time of thread trimming	Compensation value of needle thread tension at the time of thread trimming of the sewing machine 	*4	1
S053	Compensation of needle thread tension at the time of stop	Compensation value of needle thread tension at the time of stop of the sewing machine 	*4	1
S054	(When the needle thread clamp unit is selected as an option) Compensation of needle thread tension for drawing needle thread clamped by the needle thread clamp unit	Compensation value of the needle thread tension for drawing the needle thread after the needle thread clamp unit has clamped the needle thread 	*4	1
S090	Basting pattern number	0 : Without basting 1 to 99 : Basting pattern number 	0 to 99	1
S091	Cloth opener operation is prohibited during basting	 0 : Cloth opener operates during basting  1 : Cloth opener operation is prohibited during basting	-	1

No.	Setting item	Description	Setting range	Unit
S092	Number of stitches for sewing a radial stitch eyelet	Number of stitches in the case of sewing a radial stitch eyelet (for 360 °)	9 to 100 stitch	1 stitch
S093	Overlap stitching angle for the radial stitch eyelet	The overlap stitching angle at the beginning of sewing a radial stitch eyelet	0 to 60(1°)	1°
S094	Radial stitch eyelet diameter	Sewing hole diameter when sewing radial stitch eyelets	0.5 to 0.7mm (0.1mm)	0.1mm

*1 : Knife No.

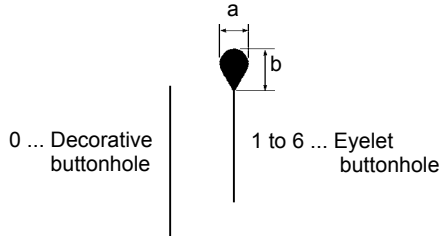

No.	a×b
1	2.1×3.2
2	2.5×3.8
3	2.9×4.4
4	3.0×4.6
5	3.2×5.4
6	2.7×5.1

*2 : Setting range of cut length

Specifications	Thread trimming type	Eyelet buttonhole setting range	Lockstitch buttonhole setting range
J type	Needle thread trimmer type	10 to 38mm	5 to 38mm
	Overall thread trimmer type	10 to 34mm	5 to 34mm
C type	Needle thread trimmer type	10 to 38mm	5 to 38mm
	Overall thread trimmer type	10 to 34mm	5 to 34mm

*3 : Setting range of the number of stitches of parallel section, of taper bar and of straight bar
The number of stitches using the stitch length in the range from 0.5 to 4.0 mm

*4 : Needle thread tension compensation value setting range

$$0 \leq (\text{Data S040 Needle thread tension}) + (\text{Data S041 to S051 Respective compensation values of needle thread}) \leq 200$$

$$0 \leq (\text{Memory switch U008 Needle thread tension when the sewing machine's needle thread trimmer trims the needle thread}) + (\text{Data S052 Compensation value of needle thread tension at the time of thread trimming}) \leq 200$$

$$0 \leq (\text{Memory switch U010 Needle thread tension when the sewing machine stops}) + (\text{Data S053 Compensation value of needle thread tension when the sewing machine stops}) \leq 200$$

(When the needle thread clamp unit is selected as an option)

$$0 \leq (\text{Memory switch U033 Needle thread tension when needle thread clamp unit trims the thread}) + (\text{Data S052 Compensation value of needle thread tension at the time of thread trimming}) \leq 200$$

$$0 \leq (\text{Memory switch U034 Needle thread tension when the needle thread clamp unit draws the needle thread}) + (\text{Data S054 Compensation value of needle thread tension when the needle thread clamp unit draws the needle thread}) \leq 200$$