

ENGLISH

**LZ-2290A-SR / IP-110D / SC-916
INSTRUCTION MANUAL**

* "CompactFlash(TM)" is the registered trademark of SanDisk Corporation, U.S.A.

CONTENTS

1. NAME OF EACH COMPONENT	1
2. SPECIFICATIONS.....	2
2-1. Specifications of the machine head	2
2-2. Specifications of the electrical box	2
3. STITCH PATTERN TABLE	3
3-1. Initial value of the stitch pattern and the table	4
4. INSTALLATION.....	6
4-1. Installation of the sewing machine head	6
4-2. Removing the needle bar stopper	7
4-3. Attaching the knee-lifter	7
4-4. Adjusting the height of the knee lifter	7
4-5. Installing the electrical box	8
4-6. Connecting the power switch cord (Japan and general export area)	8
4-7. Installing the operation panel (IP-110 (D))....	8
4-8. Connecting the cords	9
(1) Preparation of wiring	9
(2) Connecting the connectors	10
4-9. Attaching the connecting rod.....	14
4-10. Adjustment of the pedal.....	15
4-11. Installing the thread stand.....	15
4-12. Installing the bird's nest prevention (CB) type sewing machine.....	15
4-13. Lubrication.....	17
4-14. Test run	18
(1) Turn ON the power.....	18
(2) How to operate the pedal.....	18
5. PREPARATION BEFORE SEWING	19
5-1. Inserting the needle	19
5-2. Removing the bobbin case.....	19
5-3. Winding the bobbin thread.....	19
5-4. Placing the bobbin case and the bobbin ...	20
5-5. Threading the machine head.....	21
5-6. Adjusting the stitch length	21
5-7. Adjusting the condensation stitching	21
6. HOW TO USE THE OPERATION PANEL	22
6-1. Names and functions of the respective sections.....	22
6-2. Before setting the pattern.....	24
(1) Limitation of the max. zigzag width	24
(2) Setting the reference of stitch base line	26
(3) Setting the feed amount.....	27
6-3. Basic screen	28
6-4. List of the display pictographs of each screen.....	29
6-5. Setting the sewing pattern	52
(1) Selecting the zigzag pattern	52
6-6. Setting of the sewing shape.....	54
(1) 2-step zigzag, 3-step zigzag and 4-step zigzag stitch.....	54
(2) Scallop stitching	56
(3) Blind stitch sewing	59
(4) Custom pattern stitching	60
(5) T stitch, left.....	61
(6) T stitch, right.....	62
(7) Pattern 1	64
(8) Pattern 2 (fagoting)	65
(9) Pattern 3	67
(10) Pattern 4	69
6-7. Setting of the number of rotations	71
6-8. Reverse feed stitching	71
(1) Standard condensation	72
(2) 2-point condensation.....	74
(3) Condensation custom	75
(4) Comparison table of the reverse stitch of each shape.....	76
6-9. Selection of the kind of stitching	77
(1) Overlapped stitching	77
(2) Programmed stitching	78
6-10. Custom pattern.....	80
(1) Custom pattern setting.....	80
(2) New creation of the custom pattern	81
(3) Custom pattern edit.....	82
(4) Pattern sewing registration, custom pattern copy and custom pattern deletion of the custom pattern... ..	82
6-11. Condensation Custom	84
(1) Condensation custom setting.....	84
(2) Condensation custom edit	85
6-12. Pattern stitching	87
(1) Setting the pattern stitching	87
(2) Registering the pattern stitching	89
(3) Copy and deletion of the pattern stitching.....	89
6-13. Continuous stitching	91
(1) New creation of the continuous stitching	91
(2) Continuous stitching edit.....	92
(3) Copy and deletion of the continuous stitching ...	94
6-14. Cycle stitching.....	95
(1) New creation of the cycle stitching.....	95
(2) Cycle stitching edit.....	95
(3) Copy and deletion of the cycle stitching.....	97
(4) Teaching.....	98
(5) Performing the constant-dimension stitching using the cycle stitching.....	99
6-15. Counter.....	99
(1) Thread trimming counter.....	99
(2) Bobbin thread counter.....	99
6-16. Information.....	100
(1) Sewing common data	101
(2) Sewing management information	103
(3) Communication mode	106
6-17. Setting for functions	110
(1) How to change over to the function setting mode.....	110
(2) Function setting list	113
(3) Detailed explanation of selection of functions ..	117
6-18. External interface	122
(1) Compact flash slot	122
(2) RS-232C port.....	122
(3) General input port (Production control switch connecting connector)	122
7. SEWING.....	123
7-1. Adjusting the thread tension.....	123
7-2. Adjusting the pressure of the presser foot	124
7-3. One-touch type reverse feed stitching mechanism.....	124
7-4. Pattern 2 (fagoting) sewing	125
7-5. Hand switch	126

8. STANDARD ADJUSTMENT	127	9. MAINTENANCE	136
8-1. Adjusting the amount of oil in the hook ..	127	9-1. Replacing the power fuse.....	136
8-2. Adjusting the amount of lubricating to face plate section	127	9-2. Adjusting the contrast of the operation panel display	137
8-3. Adjusting the height of the presser bar ...	128	9-3. Draining (Bird's nest prevention (CB) type only)....	137
8-4. Adjusting the micro-lifting mechanism of the presser foot	128	9-4. Cleaning the dust bag (Bird's nest prevention (CB) type only)....	137
8-5. Height and inclination of the feed dog	128	9-5. Cleaning the cooling fan installed on the under cover	138
8-6. Hook adjusting mode.....	129	9-6. Cleaning the hook section.....	138
8-7. Attaching / removing the hook.....	130	9-7. Cleaning the rear cover of the control box	138
8-8. Adjusting height of the needle bar	131	9-8. Cleaning the operation panel screen	138
8-9. Adjusting the needle-to-hook timing and the needle guard	131	9-9. Replacing procedure of the hook shaft oil wick.....	139
8-10. Adjusting the stop position of the needle.....	132	9-10. Applying the exclusive grease.....	139
8-11. Adjusting the thread trimmer	132	10. AT A TIME LIKE THIS !.....	140
8-12. Adjusting the needle thread feeding device	133	11. ERROR DISPLAY.....	141
8-13. Adjusting the bird's nest prevention (CB) type wiper	134	11-1. Error code list (Error display in panel) ...	142
8-14. Replacing procedure of the bird's nest prevention (CB) type presser knife.....	135	12. TROUBLES AND CORRECTIVE MEASURES.....	146

1. NAME OF EACH COMPONENT

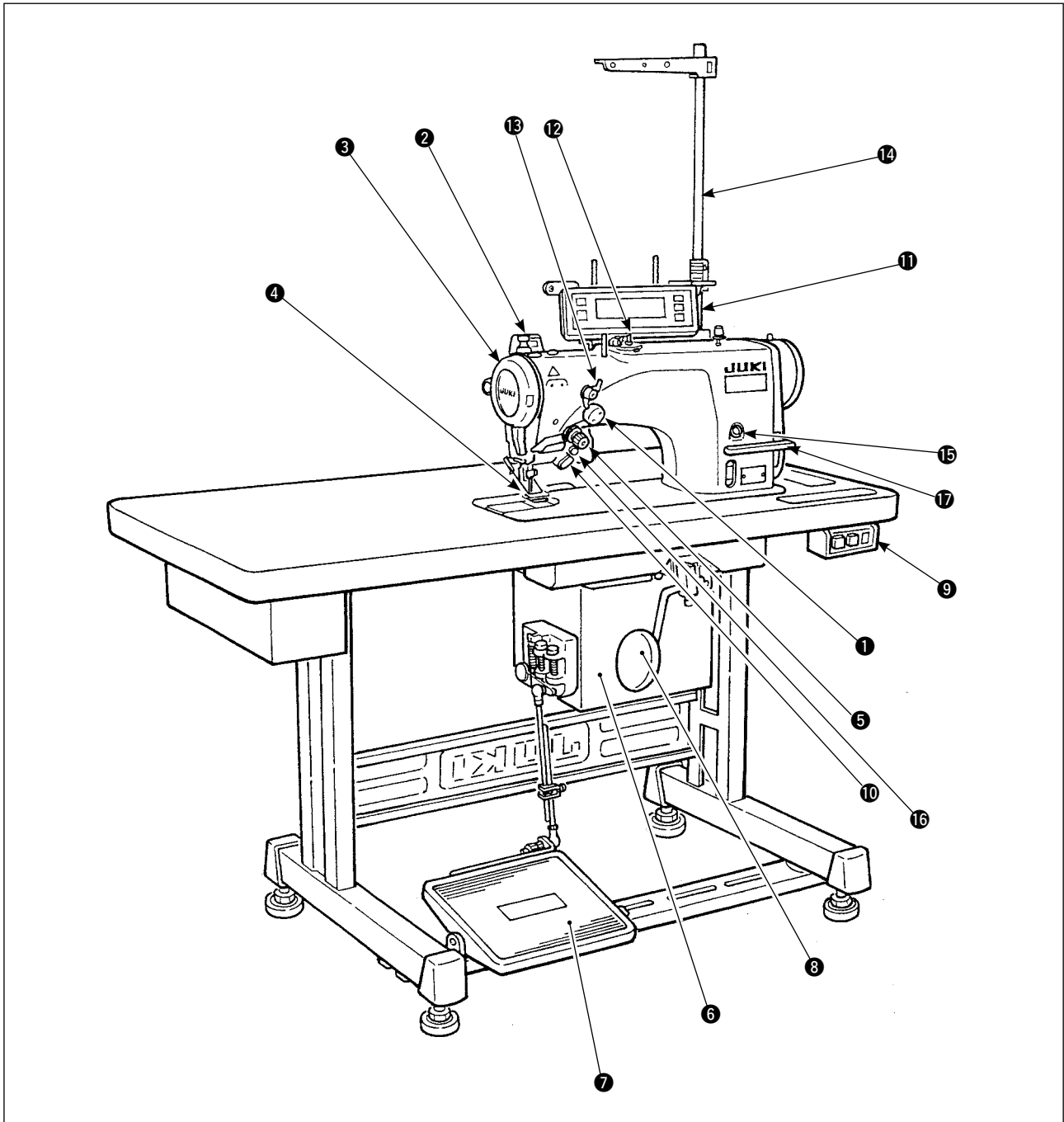

- | | | |
|--|--|------------------------------|
| ① Needle thread draw-out device | ⑧ Knee lifter lever | ⑮ Oil supply opening |
| ② Wiper switch | ⑨ Power switch | ⑯ Mirror inversion switch |
| ③ Thread take-up cover | ⑩ Hand switch | ⑰ Reverse feed control lever |
| ④ Finger guard | ⑪ Control panel | |
| ⑤ Thread tension controller (Rotary tension) | ⑫ Bobbin winder | |
| ⑥ Electrical box | ⑬ Tension controller No.1
(Pre-tension) | |
| ⑦ Pedal | ⑭ Thread stand | |

2. SPECIFICATIONS

2-1. Specifications of the machine head

Model (Minute-quantity lubricating type)	LZ-2290A-SR-7-WB	LZ-2290A-SR-7-CB
Application	Light-weight materials to medium-weight materials	
Max. sewing speed	5,000 sti/min (*1)	
Max. zigzag width	10 mm (*2)	
Max. feed pitch	5 mm (normal/reverse feed)	
Stitch pattern	14 kinds 20 patterns	
Needle	SCHMETZ 438 #75 (Needle at the time of delivery)	
Oil used	JUKI New Defrix Oil No. 1	
Thread trimmer	With	
Feed method	Standard feed (Computer controlled system)	
Wiper method	Front sweeping method	Side sweeping method
Thread clamp method	---	Air clamp method
Noise	- Equivalent continuous emission sound pressure level (L _{pA}) at the workstation: A-weighted value of 80 dB; (Includes K _{pA} = 2.5 dB); according to ISO 10821- C.6.2 -ISO 11204 GR2, at 4600 sti/min.	

- * 1. The max. sewing speed is set to 4,000 sti/min at the time of delivery (depending on the delivery area).
- The speed is limited by setting of the zigzag width of the sewing pattern and feed amount since the speed is controlled by the amount of zigzag width per stitch and feed amount.
 - Properly set the number of revolution in accordance with the product to be sewn and process.
- * 2. Max. zigzag width is limited to 8 mm at the time of standard delivery.

2-2. Specifications of the electrical box

■ For general export

Supply voltage	Single phase 200V / 220V / 240V	3-phase 200V / 220V / 240V
Frequency	50 Hz / 60 Hz	
Electric power	600VA	
Operating environment	Temperature : 0 to 40°C Humidity : 90% or less	

■ For CE

Supply voltage	Single phase 220V / 230V / 240V	
Frequency	50 Hz / 60 Hz	
Electric power	600VA	
Operating environment	Temperature : 0 to 40°C Humidity : 90% or less	





■ For JUS



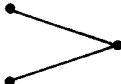
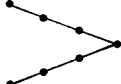
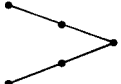

Supply voltage	Single phase 100V / 110V / 120V	3-phase 200V / 220V / 240V
Frequency	50 Hz / 60 Hz	
Electric power	600VA	
Operating environment	Temperature : 0 to 40°C Humidity : 90% or less	

3. STITCH PATTERN TABLE

Name of pattern		Stitch pattern	Number of stitches for pattern	Max.zigzag width	Remarks
Straight stitch			1	—	
2-step zigzag stitch			2	10	
3-step zigzag stitch			4		
4-step zigzag stitch			6		
Scallop (right)	Standard scallop		24		
	Crescent scallop				
	Equal-width scallop				
	Equal-width scallop		12		
Scallop (left)	Standard scallop		24		
	Crescent scallop				
	Equal-width scallop				
	Equal-width scallop		12		
Blind stitch (right)			2 + a		
Blind stitch (left)					
Custom pattern		--	500		
T stitch (left)			3		
T stitch (right)					
Pattern 1			6		
Pattern 2 (fagoting)					
Pattern 3					
Pattern 4					

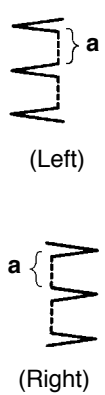
3-1. Initial value of the stitch pattern and the table

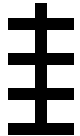
	1	2	3	4	5	6	
	Straight stitch	2-step zigzag stitch	4-step zigzag stitch	3-step zigzag stitch	Scallop 24 stitches	Scallop 12 stitches	
					 Standard scallop  Crescent scallop  Equal-width scallop		
Zigzag width	---	4.0	8.0	6.0	8.0	8.0	
Normal feed amount	2.0	1.5	1.0	1.0	0.5	0.8	
Reverse feed amount	0.0	0.0	0.0	0.0	0.0	0.0	
Number of stitches	---	---	---	---	---	---	
Related input	P. 31, 54, 55	P. 32, 54, 55	P. 32, 54, 55	P. 32, 54, 55	P. 32, 33, 56, 57, 58, 101, 102	P. 32, 33, 56, 57, 58, 101, 102	
Related mechanical adjustment					P. 126	P. 126	
Remarks							

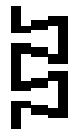
	7	8	9	10	11	12	13
	Blind stitch	Custom pattern	T stitch	Pattern 1	Pattern 2 (Fagoting)	Pattern 3	Pattern 4
	 <p>(Left)</p> <p>(Right)</p>		 <p>(Left)</p> <p>(Right)</p>				
	3.0	---	3.0	6.0	6.0	6.0	6.0
	1.5	---	2.5	2.5	1.6	2.1	2.0
	0.0	---	0.0	0.0	- 2.0	2.4	- 2.0
	4	---	---	---	---	---	---
	P. 34, 59	P. 45, 60, 80, 81, 82, 83, 98, 99, 101, 102	P. 35, 36, 37, 38, 61, 62, 63	P. 37, 38, 64, 65	P. 39, 40, 65, 66, 67	P. 41, 42, 67, 68	P. 43, 44, 69, 70
					P. 125		
		There are cases where the stitch shapes are not stabilized in case of some patterns which frequently repeat normal and reverse feed stitching. Use the machine at the sewing speed of approximately 2,000 sti/min.					

4. INSTALLATION

WARNING :



- Perform the installation of the sewing machine by the technical personnel who have been trained.
- To prevent personal injury, ask our dealer or the electrician for electric wiring.
- Be sure to perform the work with two persons or more when transporting the sewing machine and use a lorry when moving it.
- To prevent personal injury caused by abrupt start of the sewing machine, do not connect the power plug until the set-up of the sewing machine is completed.
- Be sure to earth the ground wire to prevent personal injury caused by leak.
- Be sure to attach safety protection cover, finger guard, etc.

4-1. Installation of the sewing machine head

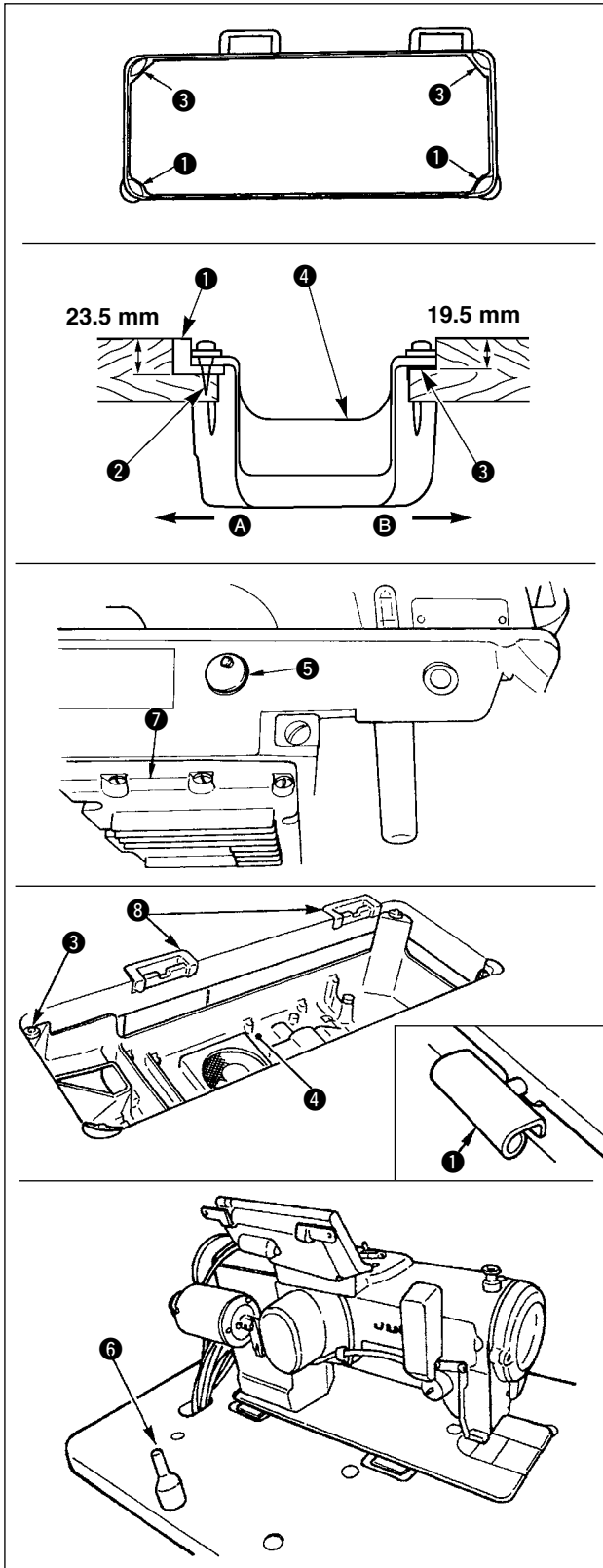

■ Installing the under cover

- 1) The under cover should rest on the four corners of the machine table groove.
 - 2) Fix two rubber seats ① on side A (operator's side) using nails ② as illustrated above. Fix two cushion seats ③ on side B (hinged side) using a rubber-based adhesive. Then place under cover ④ on the fixed seats.
 - 3) Remove air vent cap ⑤ attached to the machine bed. (Be sure to attach cap ⑤ when transporting the machine head in the state that the machine head is removed from the machine table.)
- Caution** If the sewing machine is operated without removing air vent cap ⑤, oil leakage from gear box portion ⑦ may occur.
- 4) Fit hinge ① into the opening in the machine bed, and fit the machine head to table rubber hinge ⑧ before placing the machine head on cushions ③ on the four corners.
 - 5) Attach head support rod ⑥ to the machine table.

4-2. Removing the needle bar stopper

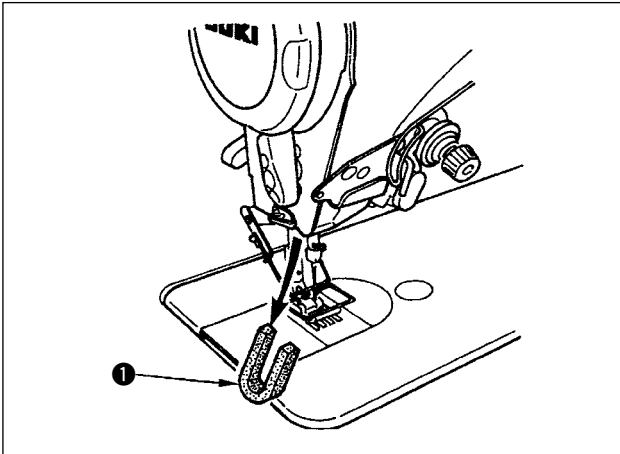

Remove needle bar stopper ❶ for transportation.



Keep the needle bar stopper which has been removed, and install this needle bar stopper when transporting the sewing machine. The needle bar stopper may be cut when it is strongly drawn out. Slightly move the needle bar to the right or left and slowly draw out the needle bar stopper.

4-3. Attaching the knee-lifter

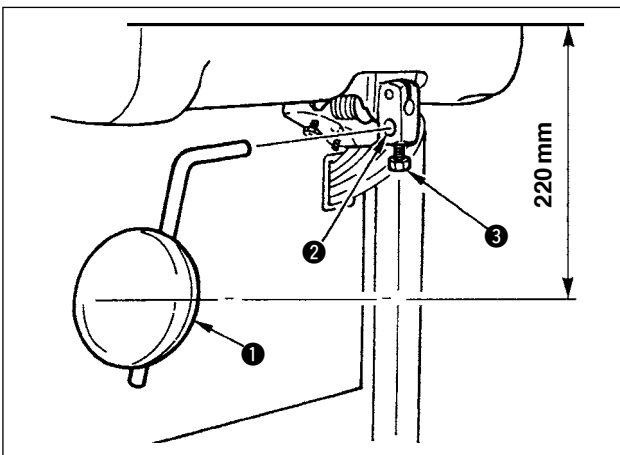

Insert knee-lifter into attaching hole ❷ and tighten it with bolt ❸.

* Adjust the position of knee lifter pad ❶ to a convenient place. For the reference dimension, the position is 220 mm from the bottom face of table.

* In case of the machine with AK device, knee lifter pad ❶ is optional. (Part No. 22934251)

4-4. Adjusting the height of the knee lifter

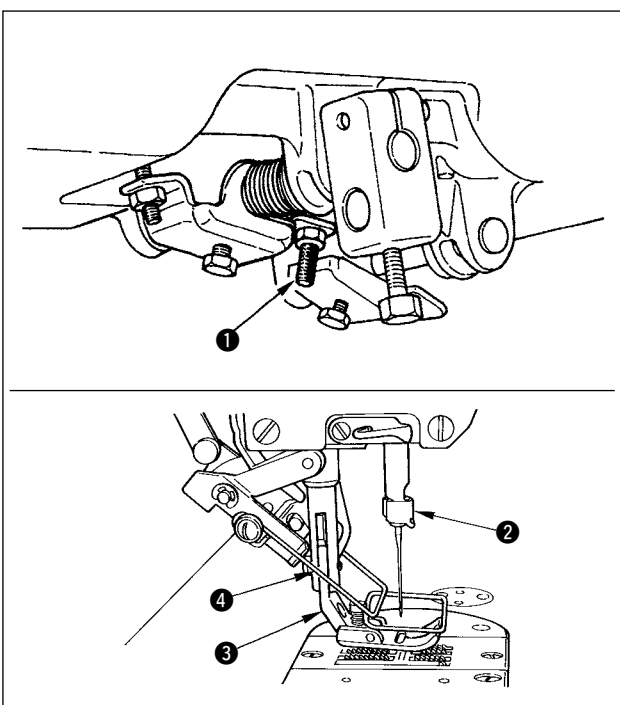

1) The standard height of the presser foot lifted using the knee lifter is 10 mm.

2) You can adjust the presser foot lift using knee lifter adjust screw ❶.



Do not operate the sewing machine in the state that presser foot ❸ is lifted by 10 mm or more since needle bar ❷ and presser foot ❸, or wiper ❹ and presser foot ❸ come in contact with each other.

4-5. Installing the electrical box

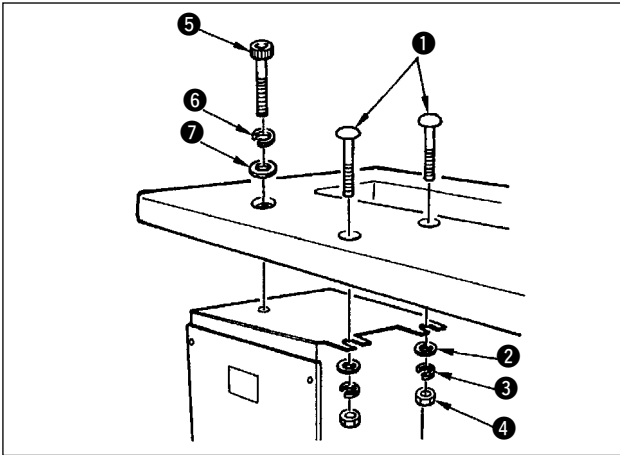

Install the electrical box on the underside of the table at the location illustrated using round-head bolt ①, plain washer ②, spring washer ③ and nut ④ supplied with the machine, and using bolt having hexagonal indentation on the head ⑤, plain washer ⑥ and spring washer ⑦ supplied with the machine.

4-6. Connecting the power switch cord (Japan and general export area)

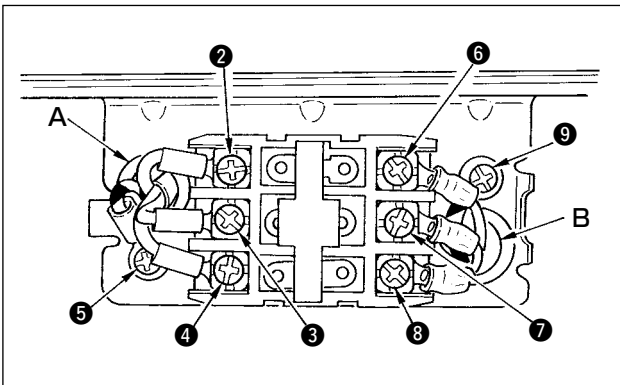
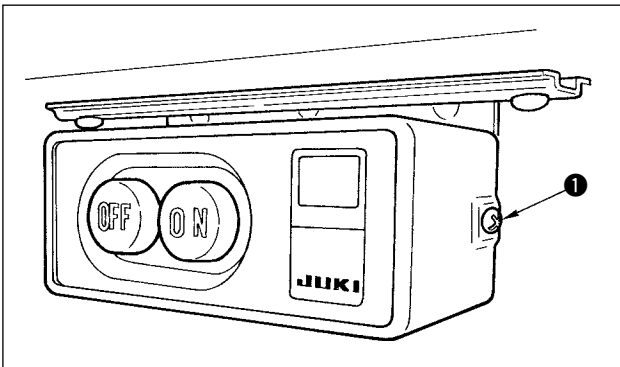

- 1) Loosen screw ① located on the side of the power switch supplied as accessories and remove the power switch cover.
- 2) Connecting the input power cord of electrical box
 - **When the input power cord of electrical box is 4P**
Put 4P cord from hole A of the power switch and securely fix green/yellow cord to ⑤, white cord to ②, black cord to ③ and red cord to ④ with screws.
 - **When the input power cord of electrical box is 3P**
Put 3P cord from hole A of the power switch and securely fix green/yellow cord to ⑤, brown cord to ② and sky blue cord to ③ with screws.
- 3) Connecting the power cable supplied as accessories
 - **In case of 3-phase power cable**
Put power cable from hole B of the power switch, and securely fix green/yellow cord to ⑨, white cord to ⑥, black cord to ⑦ and red cord to ⑧ with screws.
 - **In case of single phase power cable**
Put power cable from hole B of the power switch, and securely fix green/yellow cord to ⑨ and other cords to ⑥ and ⑦ with screws. ⑧ is not used.
- 4) Installing the power switch cover
Securely tighten screw ① located on the side of the power switch.

4-7. Installing the operation panel (IP-110 (D))

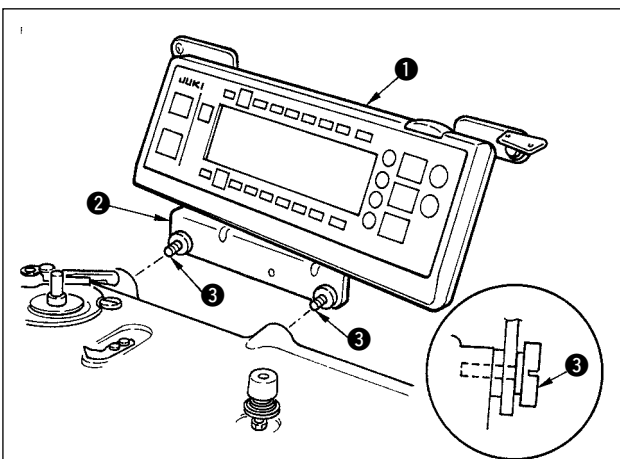

- 1) Install operation panel ① on the machine head using screws ③ which have been assembled to panel installing bracket ②.



1. Do not disassemble the operation panel to prevent it from breakage.
2. Clamp the cord coming from the panel and that of the machine head with the clip band supplied as accessories.

4-8. Connecting the cords



WARNING :

- To prevent personal injury caused by abrupt start of the sewing machine, carry out the work after turning OFF the power switch and a lapse of 5 minutes or more.
- To prevent damage of device caused by maloperation and wrong specifications, be sure to connect all the corresponding connectors to the specified places.
- To prevent personal injury caused by maloperation, be sure to lock the connector with lock.
- As for the details of handling respective devices, read carefully the Instruction Manuals supplied with the devices before handling the devices.

(1) Preparation of wiring

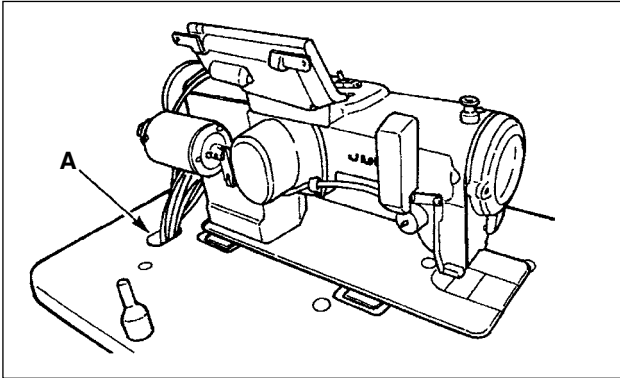

- 1) Pass the cords coming from the machine head to the underside of the table through hole A in the table.

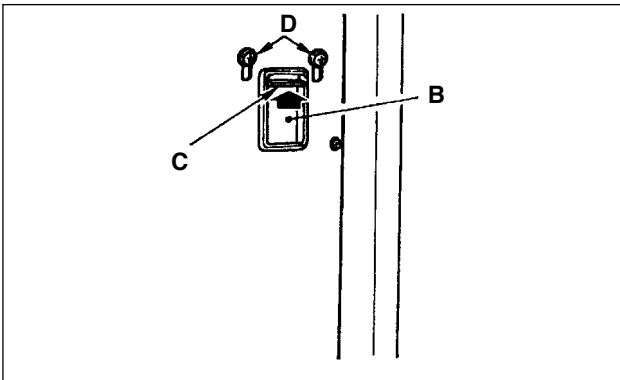

- 2) Loosen screws D and lift cord presser plate C of cord passing hole B located on the front cover to the top and temporarily tighten the plate.

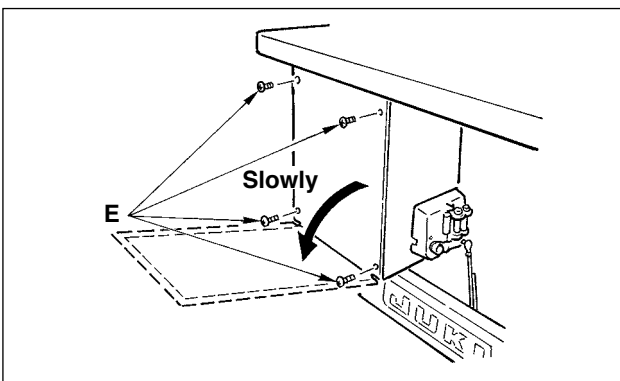

- 3) Remove four ⊕ screws fixing the rear cover of the electrical box.

(Caution) Do not touch other ⊖ screws.

When opening the rear cover, pressing it with your hands, slowly open it by approximately 70° until it stops as illustrated.



Be sure to lend your hand to the rear cover in order not to let the rear cover fall. In addition, do not apply force to the rear cover opened.

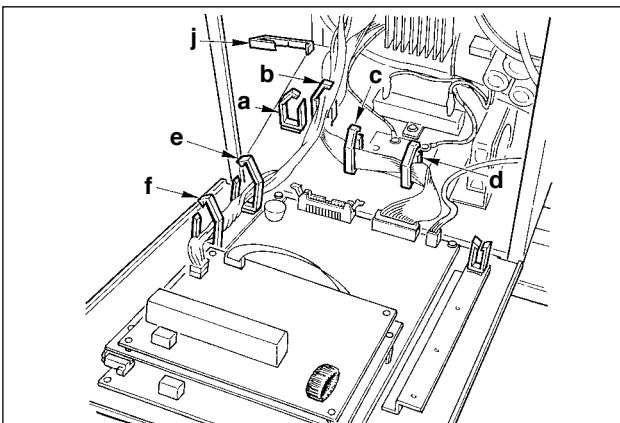

- 4) Remove the locks of cord clamps a, b, c, d, e, f and j.

How to remove the cord clamp

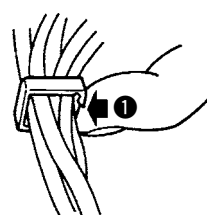

- ① Lightly pressing
- ② Pull down the clamp.
- ③ The clamp goes up.

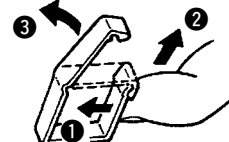

* See P.14 for how to lock the cord clamp.

(2) Connecting the connectors



- Each connector has the inserting direction. Check the direction and securely insert it. (In case of the type with lock, insert up to the lock.)
- If the connector is forcibly inserted, trouble or accident will be caused.
- Never pull out the connectors inserted at the time of delivery.
- The sewing machine fails to work if the connectors are not properly inserted. Not only the problem such as the error warning or the like but also breakage of the sewing machine or electrical box will occur.

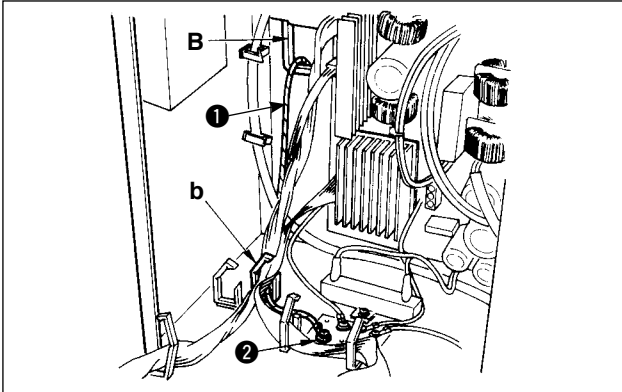

Connect cords in the following order.

- 5) Insert yellow/green earth cord ① coming from the machine head inside the electrical box through front cover through hole B, and pass it through cord clamp "b" as illustrated and tighten it with screw at the position ② in the illustration.

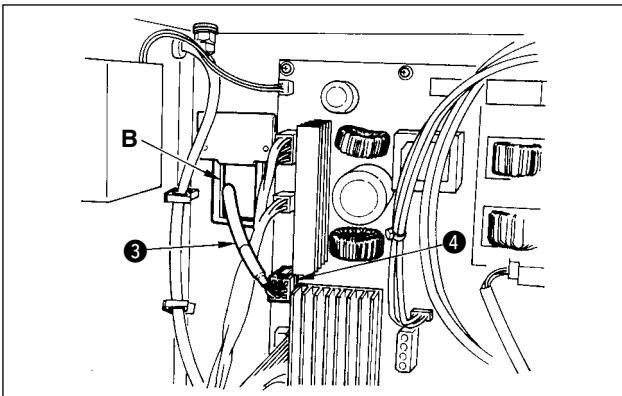

- 6) Insert white square connector 9P black cord ③ coming from the machine head inside the electrical box through front cover through hole B, and insert it into connector CN38 ④ of the circuit board attached to the front cover.

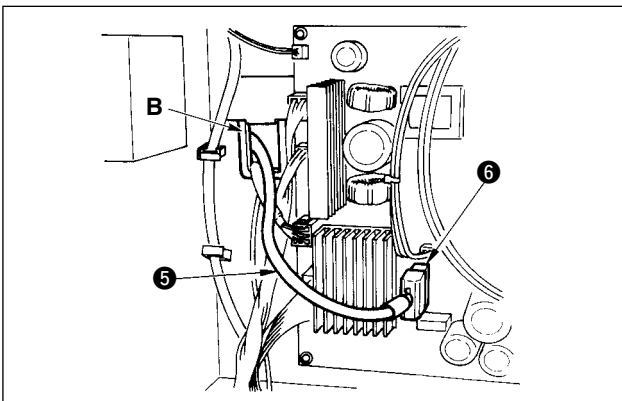

- 7) Insert white connector 4P black cord ⑤ coming from the machine head inside the electrical box through front cover through hole B, and insert it into connector CN21 ⑥ of the circuit board attached to the front cover.

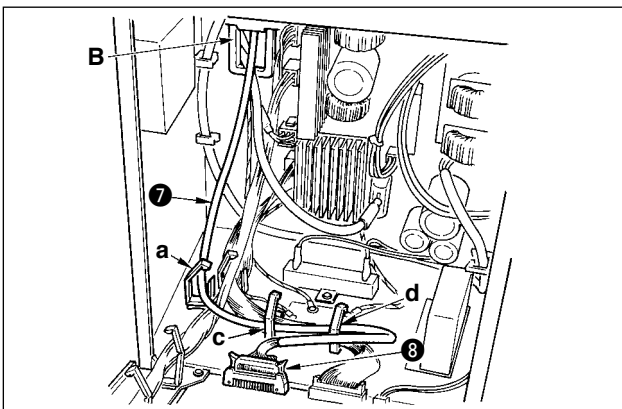

- 8) Insert white connector 26P cord ⑦ coming from the control panel inside the electrical box through front cover through hole B, pass it through cord clamps "a", "c" and "d", insert it into connector CN34 ⑧, and lock it.

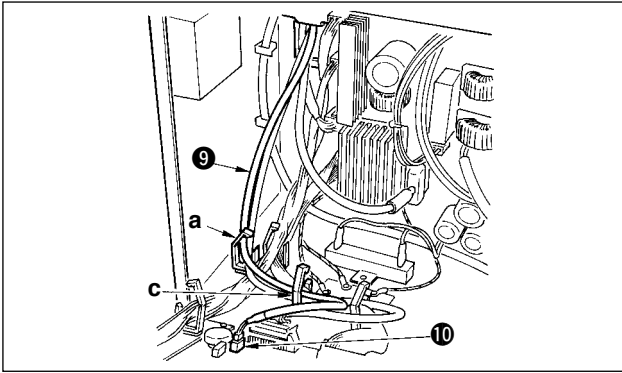

9) Insert black connector 4P white cord ⑨ coming from the machine head inside the electrical box through front cover through hole B, and insert it into connector CN31 ⑩ through cord clamps a and c.

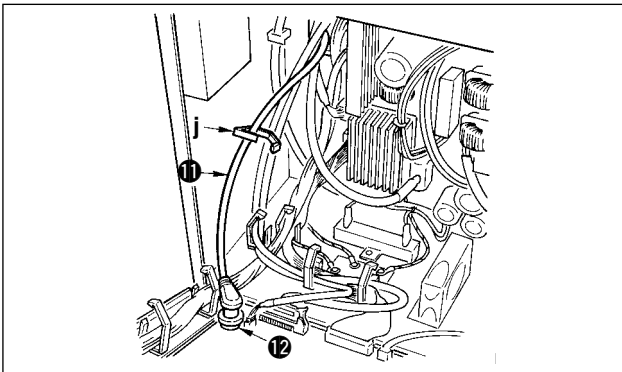

10) Insert gray round connector 7P cord ⑪ coming from the machine head inside the electrical box through front cover through hole B, pass it through cord clamp “j”, and insert it into connector CN30 ⑫.

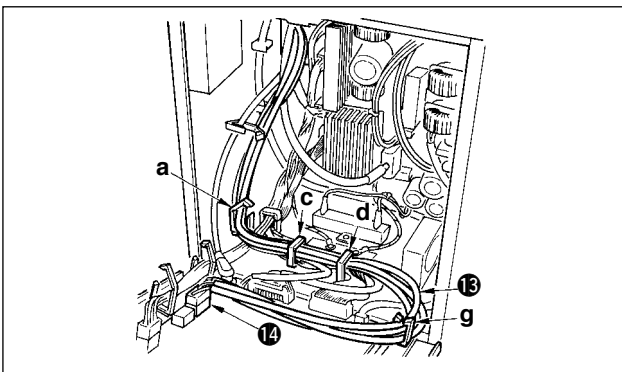

11) Insert white connector 12P cord ⑬ coming from the machine head inside the electrical box through front cover through hole B, pass it through cord clamps “a”, “c”, “d” and “g”, and insert it into connector CN53 ⑭.
Close cord clamps “a”, “c” and “d”.

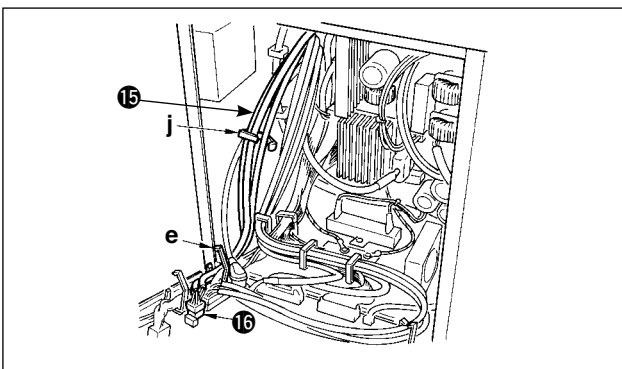

12) Insert white connector 6P cords ⑮ coming from the machine head inside the electrical box through front cover through hole B, pass it through cord clamps “e” and “j”, and insert it into connector CN54 ⑯.

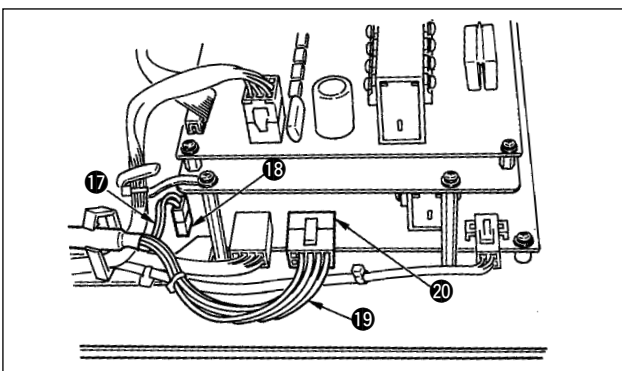

13)-1 Insert white connector 10P cord ⑰ and blue connector 2P cord ⑱ coming from the machine head inside the electrical box through front cover through hole B, pass them through cord clamps “e”, “f” and “j”, and insert the white 10P into connector CN51 ⑳ and the blue 2P into CN46 ㉘.

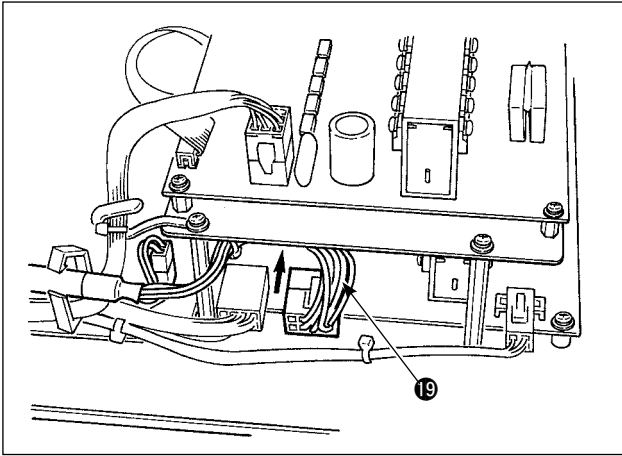

13)-2 Insert white connector 10P cord 19 coming from the machine head to the rear of the connector as shown in the figure.

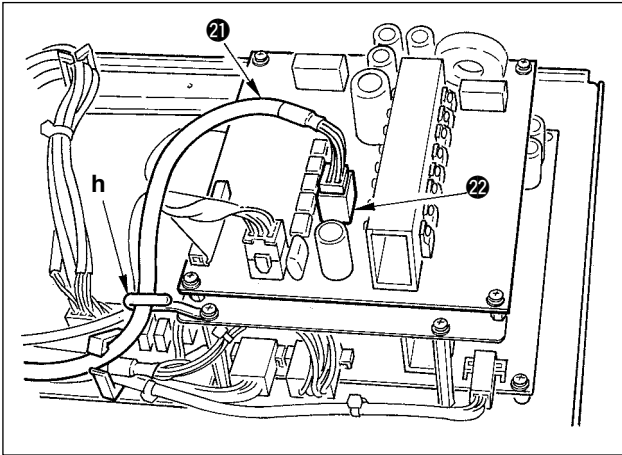

14) Insert black square connector 8P cord 21 coming from the machine head inside the electrical box through front cover through hole B, pass it through cord clamps "e", "f", "h" and "j", and insert the black square 10P into connector CN72 22.

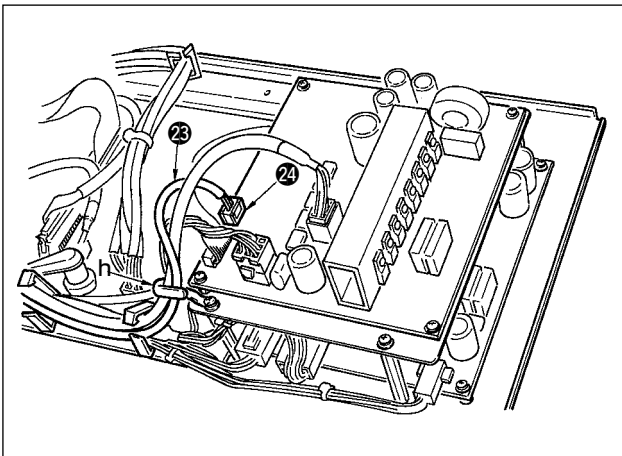

15) Insert black connector 4P cord 23 coming from the machine head inside the electrical box through front cover through hole B, pass it through cord clamps "e", "f", "h" and "j", and insert the black 4P into connector CN73 24.

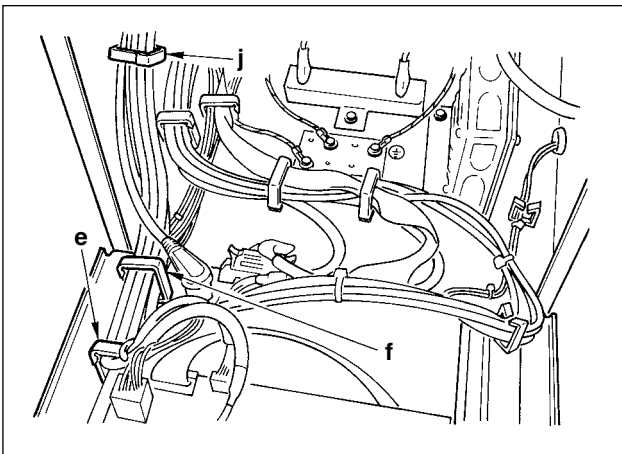

16) Close cord clamps "e", "f" and "j".

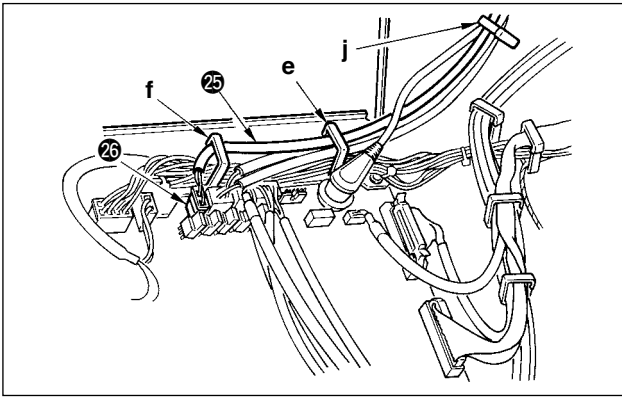

When the Auto-lifter (AK121) is used :

- 17) Insert white connector 2P cord 25 coming from the machine head inside the electrical box through front cover through hole B, pass it through cord clamps “e”, “f” and “j”, and insert it into connector CN40 26.

Change the setting of function setting No. 23 from “0” to “1” after completing all set-up procedure. For the details, see p.110 and p.113.

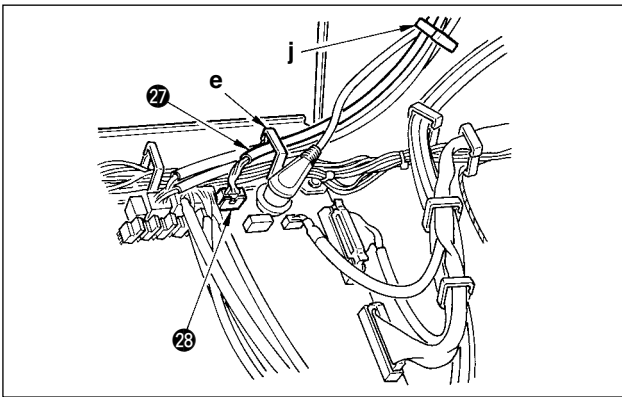

When the bird's nest prevention device is used (CB type)

- 18) Insert white small connector 6P cord 27 coming from the machine head inside the electrical box through front cover through hole B, pass it through cord clamps “e” and “j”, and insert it into connector CN52 28.

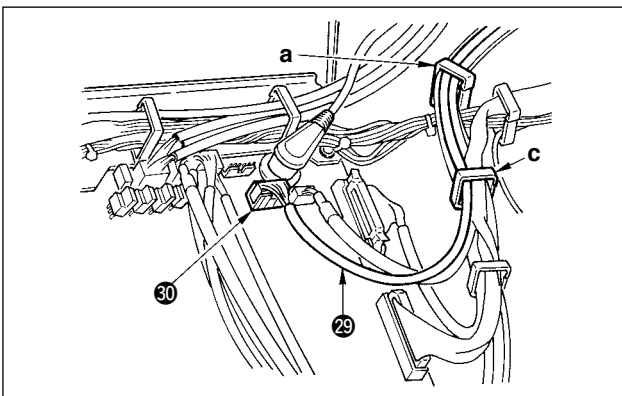

When foot pedal for standing work (PK70 or 71) is used :

- 19) Insert black connector 12P cord 29 inside the electrical box through front cover through hole B coming from the foot pedal for standing work, pass it through cord clamps “a” and “c”, and insert it into connector CN32 30.

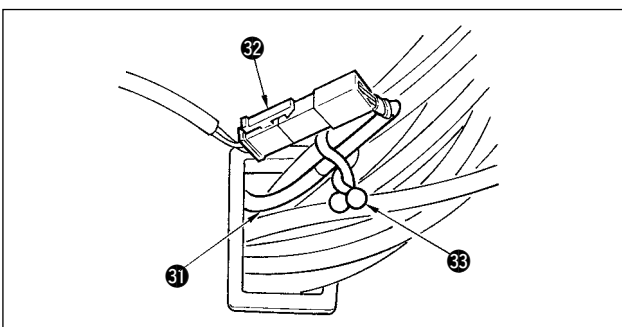

- 20) Connect white connector 2P of cord 31 supplied as accessories to which red connector 2P and white connector 2P are attached to white connector 2P 32 of under cover of the machine head.

Fix omega lock 33 supplied as accessories with the neighboring cords and cord 31 as shown in the figure.

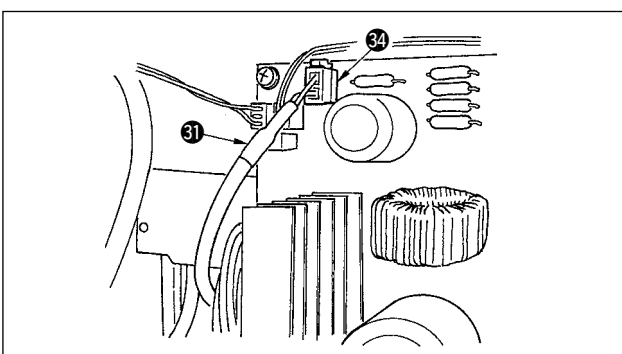

- 21) Insert red connector 2P side of cord 31 supplied as accessories to which red connector 2P and white connector 2P are attached inside the electrical box through front cover through hole, and insert it into red connector CN25 34.

How to lock the cord clamp

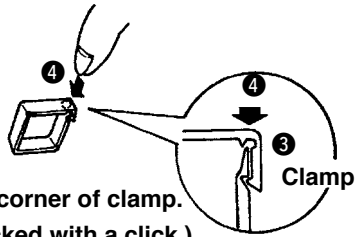

- ④ Lightly press the corner of clamp.
(Cord clamp is locked with a click.)

When the insertion of the connector is completed, lock the cord clamps.

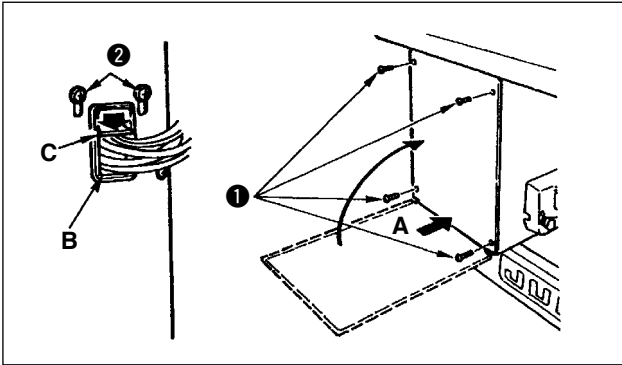

- ① Take care so that the cord is not caught between the rear cover and the electrical box main body, close the rear cover while pressing section A on the lower side of the rear cover, and tighten four ⊕ screws ①.
- ② Press down cord presser plate C of cord through hole B of the front cover, press the cord, and tighten screws ②.

[For CE territory]

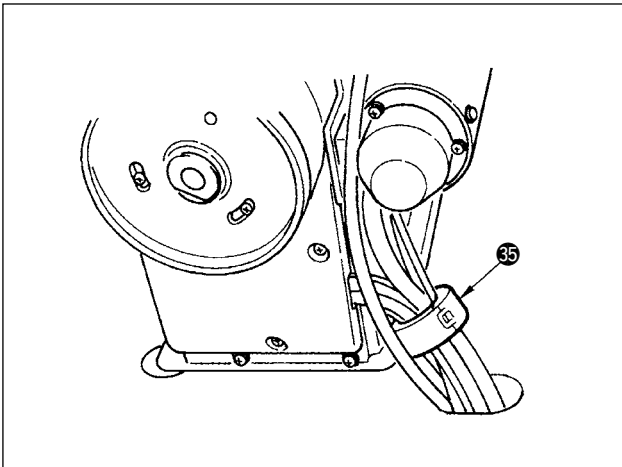

- 22) Install core clamp ③⑤ supplied as accessories at the position as shown in the figure.

4-9. Attaching the connecting rod

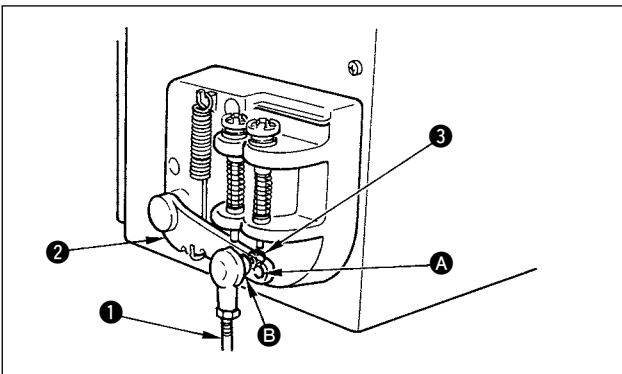

- 1) Fix connecting rod ① to installing hole ③ of pedal lever ② with nut ③.
- 2) Installing connecting rod ① to installing hole ① will lengthen the pedal depressing stroke, and the pedal operation at a medium speed will be easier.

4-10. Adjustment of the pedal

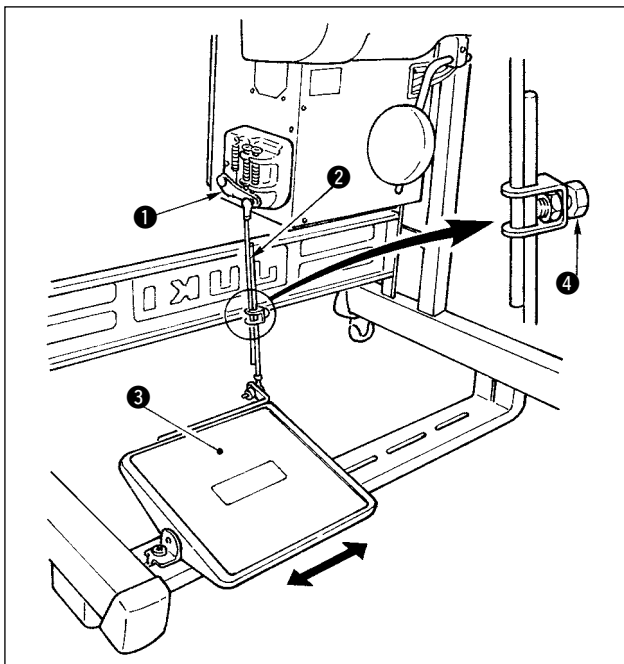

■ Installing the connecting rod

- 1) Move pedal ③ to the right or left as illustrated by the arrows so that motor control lever ① and connecting rod ② are straightened.

■ Adjusting the pedal angle

- 1) The pedal tilt can be freely adjusted by changing the length of the connecting rod.
- 2) Loosen adjust screw ④, and adjust the length of connecting rod ②.

4-11. Installing the thread stand

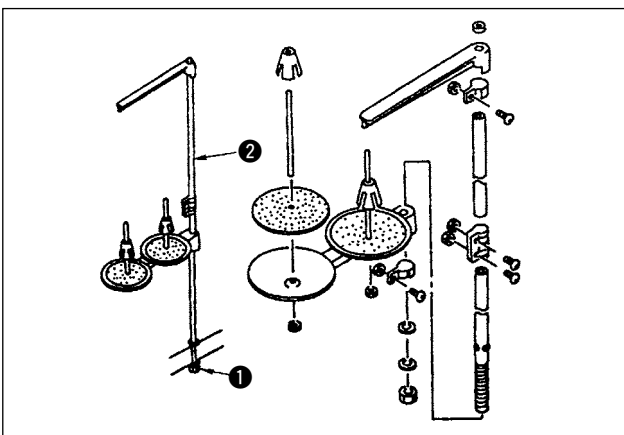

- 1) Assemble the thread stand unit, and insert it in the hole in the machine table.
- 2) Tighten locknut ① to fix the thread stand.
- 3) For ceiling wiring, pass the power cord through spool rest rod ②.

4-12. Installing the bird's nest prevention (CB) type sewing machine

(bottom surface of the machine table)

(mm)

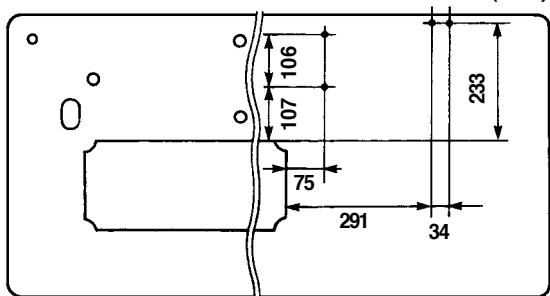

- 1) Punch dots on the positions of the setscrews of solenoid valve (asm.) and regulator (asm.) on the bottom surface of the machine table.

Besides, awling is performed on JUKI genuine table.

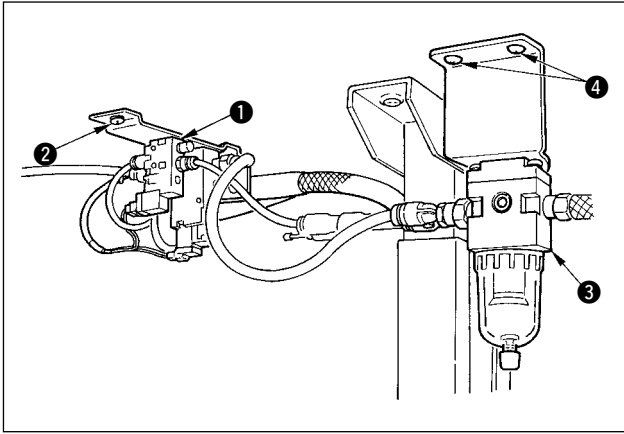

- 2) Fix solenoid valve (asm.) ① with wood screws ② supplied with the sewing machine as accessories.
- 3) Fix regulator (total asm.) ③ with wood screw ④ supplied with the sewing machine as accessories.
- 4) Connect $\phi 6$ and $\phi 8$ hoses attached to regulator (total asm.) ③ to the respective solenoid valves.

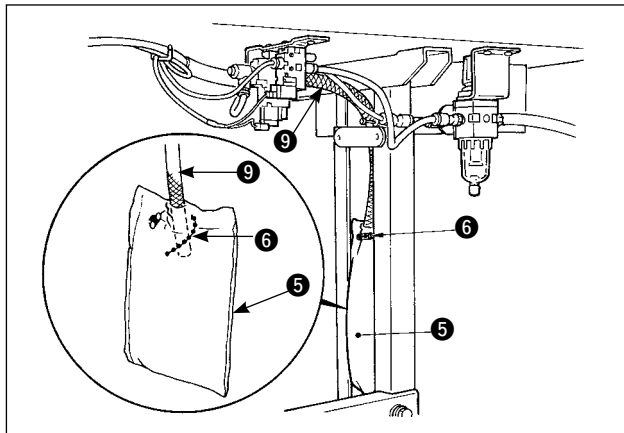

- 5) Insert dust bag ⑤ into the top end of hose ⑨ for dust bag and fix it with band ⑥ supplied with the sewing machine as accessories.

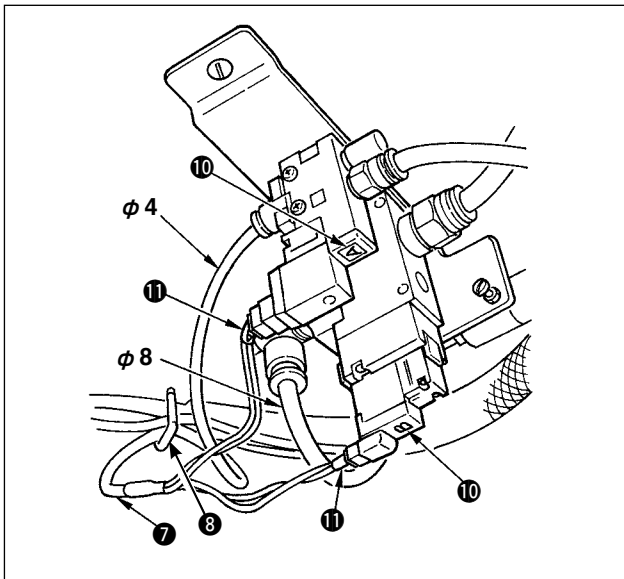

- 6) Adjust solenoid valve cord (asm.) ⑦ to the solenoid valve and the hot marker of the cord, and connect it.
Connect 6P connector ⑩⑪ to CM52 connector inside the electrical box. (Refer to "When the bird's nest prevention device is used, p. 13".)
- 7) Connect air hose $\phi 4$ coming from the machine head to the solenoid valve section and air hose $\phi 8$ to the dust bag suction port respectively.
- 8) Fix the solenoid valve and the air hose on the table with staple ⑧ supplied as accessories.

1. Fix the staple to such an extent that the air hose is not crushed.

2. Determine the position of the staple so that the cord and the air hose do not hang from the table.

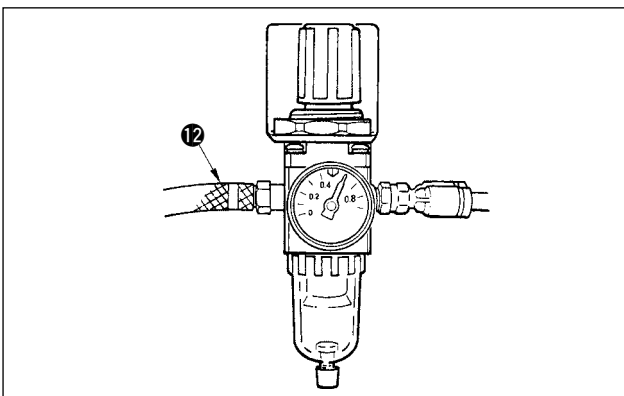

- 9) Connect the air pipe ⑫ and set the air pressure to 0.6 MPa.

Caution

• When air pressure is used under the specified value, clamp trouble will be caused.

4-13. Lubrication



WARNING :

1. Do not connect the power plug until the lubrication has been completed so as to prevent accidents due to abrupt start of the sewing machine,
2. To prevent the occurrence of an inflammation or rash, immediately wash the related portions if oil adheres to your eyes or other parts of your body.
3. If oil is mistakenly swallowed, diarrhea or vomiting may occur. Put oil in a place where children cannot reach.

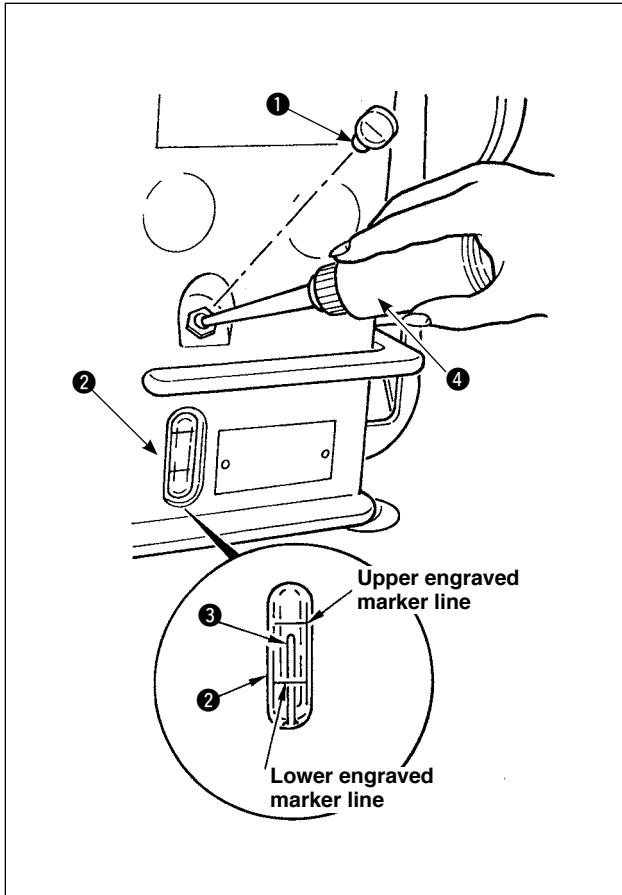

Fill the oil tank with oil for hook lubrication before operating the sewing machine.

- 1) Remove oil hole cap ① and fill the oil tank with JUKI New Defrix Oil No. 1 using the oiler supplied with the machine.
- 2) Fill the oil tank with oil up to the place where the top of oil amount indicating rod ③ aligns with the upper engraved line of oil amount indicating window ②.

If the oil is filled excessively, it will leak from the air vent hole in the oil tank or proper lubrication will be not performed. So, be careful.

- 3) When you operate the sewing machine, refill oil if the top end of oil amount indicating rod ③ comes down to the lower engraved marker line of oil amount indicating window ②.



- When you use a new sewing machine or a sewing machine after an extended period of disuse, run your machine at 3,000 to 3,500 sti/min for the purpose of break-in.
- For the oil for hook lubrication, purchase JUKI New Defrix Oil No. 1 (Part No. : MDFRX1600C0).
- For oiling, perform with oiler (B19210120A0) ④ supplied as accessories. Be careful that dust such as thread waste or the like is not oiled when oiling.

4-14. Test run

(1) Turn ON the power



WARNING :

- Check again the power voltage before connecting the power cord.
- Check that the power switch is turned OFF and connect the power cord to the power receptacle.
- Be sure to connect the earth wire.
- In case where the buzzer keeps beeping immediately after turning ON the power, there is a possibility of the wrong connection of cord or wrong power voltage. Turn OFF the power.

1) When the needle bar is in its UP position, zigzag origin detection is performed.

2) When the needle bar is in the position other than UP position :

Display as shown in the figure below appears. Turn the handwheel to bring the needle bar to needle UP position and the display changes to the next screen. Then the needle moves left and right, and zigzag origin detection is performed.

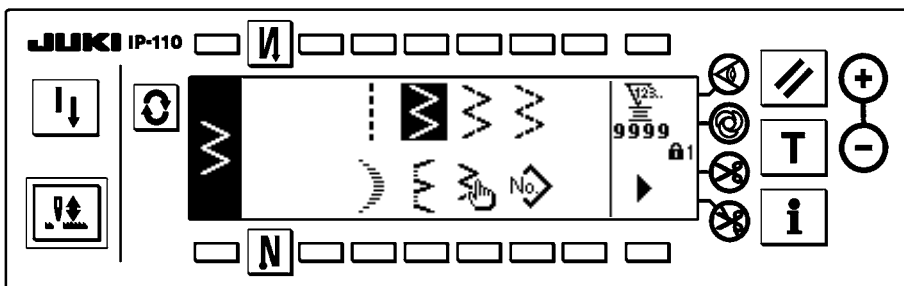
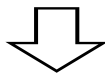
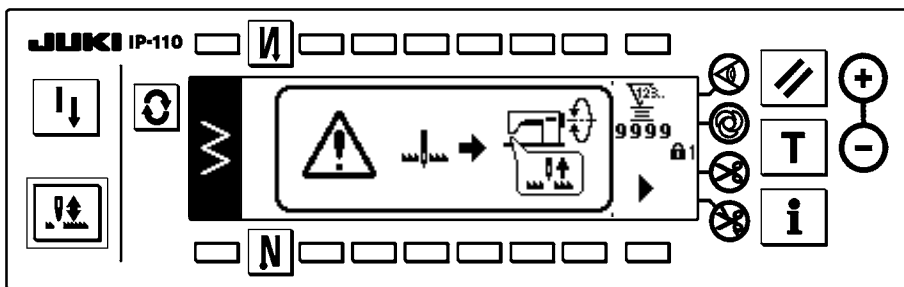

(2) How to operate the pedal

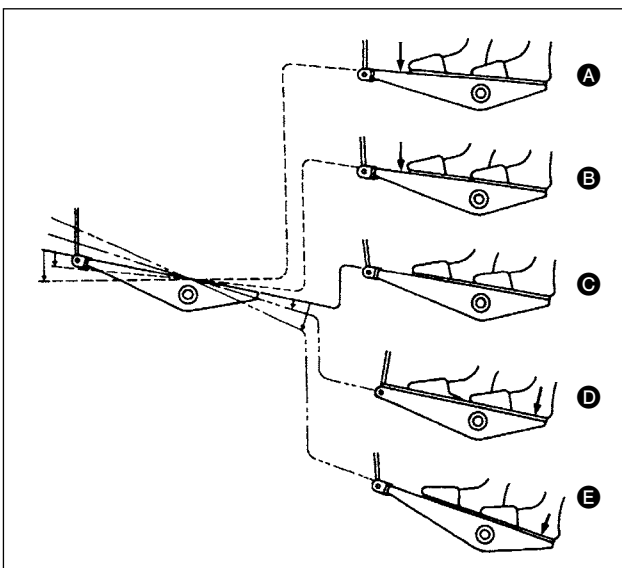

The pedal is operated in four stages.

- 1) Lightly depress the front part of the pedal for low-speed operation **B**.
- 2) Further depress the front part of the pedal for high-speed operation **A**. (Note that the sewing machine will enter the high-speed operation mode after the completion of reverse feed stitching if the automatic reverse feed stitching function is specified with the corresponding switch.)
- 3) Bring the pedal back to its neutral position, and the sewing machine will stop running **C**. (The needle stops in the highest / lowest position.)
- 4) Strongly depress the back part of the pedal, and the thread trimmer will be actuated **E**.
Lightly depress the back part of the pedal, and the presser foot will go up **D**. Further depress the back part of the pedal, and the thread trimmer will be actuated.



One stitch only becomes soft start (approximately 200 sti/min) by pedal operation immediately after turning ON the power.

5. PREPARATION BEFORE SEWING

5-1. Inserting the needle



WARNING :

To protect against possible personal injury due to abrupt start of the machine, be sure to start the following work after turning the power off and ascertaining that the motor is at rest.

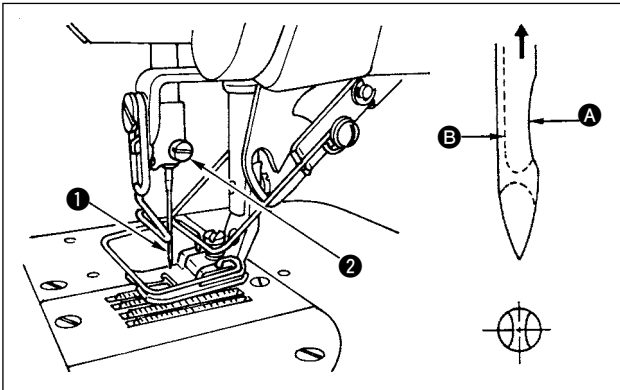

- 1) Turn the handwheel by hand to raise the needle to its highest position.
- 2) Loosen the needle clamp screw ②. Hold the needle ① so that the long groove B on the needle is facing exactly toward you.
- 3) Insert the needle deep into the hole of the needle bar in the direction of the arrow until it will go no further.
- 4) Securely tighten the screw ②.
- 5) Confirm that the long groove B on the needle faces toward you.

5-2. Removing the bobbin case



WARNING :

To protect against possible personal injury due to abrupt start of the machine, be sure to start the following work after turning the power off and ascertaining that the motor is at rest.

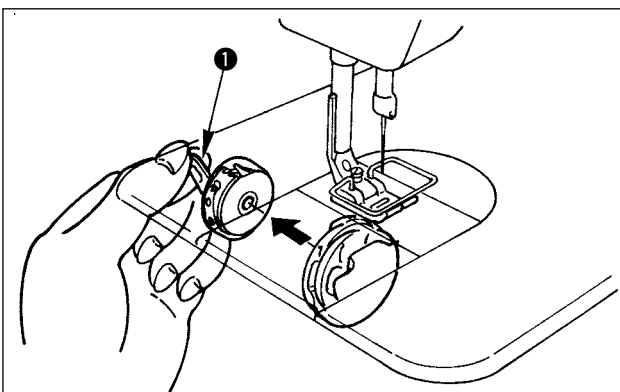

- 1) Turn the handwheel by hand to raise the needle to its highest position.
- 2) Raise bobbin case latch ① and remove the bobbin case.

5-3. Winding the bobbin thread



WARNING :

To protect against possible personal injury due to abrupt start of the machine, be sure to start the following work after turning the power off and ascertaining that the motor is at rest.

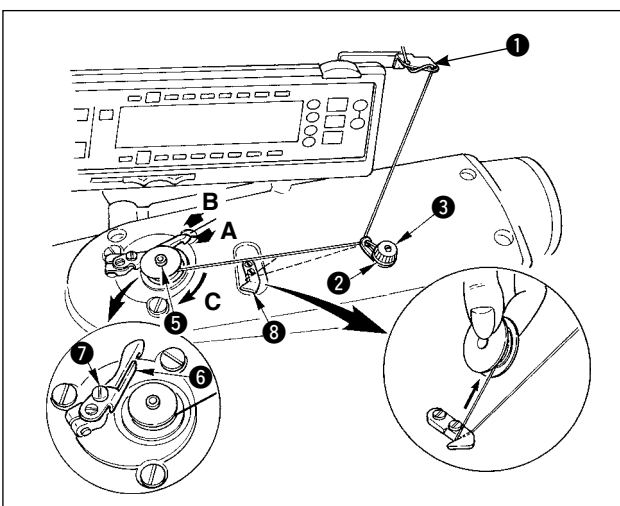

- 1) Insert the bobbin deep into the bobbin winder spindle ⑤ until it will go no further.
- 2) Pass the bobbin thread pulled out from the spool rested on the right side of the thread stand following the order from ① as shown in the figure on the left. Then, wind the end of the bobbin thread on the bobbin several times.
- 3) Press the bobbin winder adjusting plate ⑥ in the direction of A and start the sewing machine. The bobbin rotates in the direction of C and the bobbin thread is wound up. The bobbin winder spindle ⑤ will automatically stop as soon as the winding is finished.
- 4) Remove the bobbin and cut the bobbin thread with the thread cut retainer ⑧.
- 5) To adjust the winding amount of the bobbin thread, loosen setscrew ⑦ and move bobbin winder adjusting plate ⑥ to the direction of A or B. Then, tighten setscrew ⑦.

To the direction A : The amount is decreased.
To the direction B : The amount is increased.

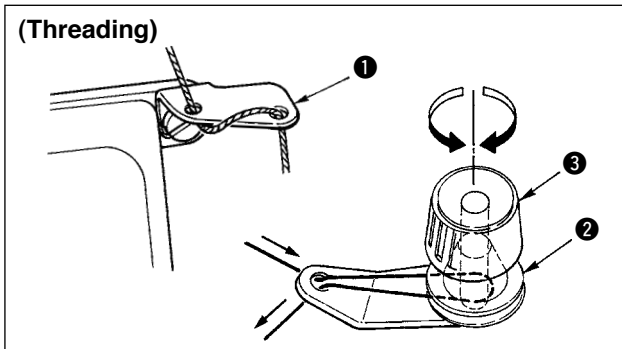
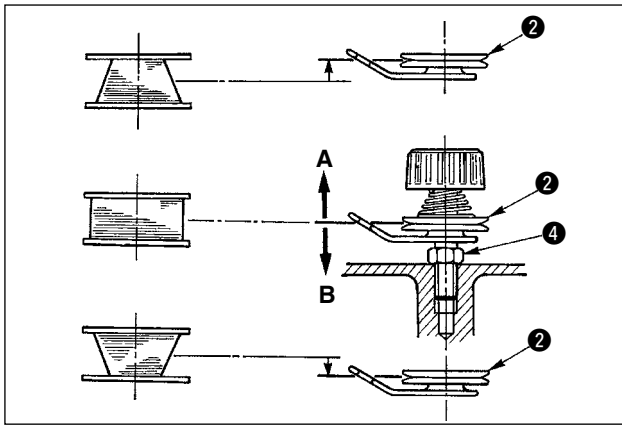

6) In case that the bobbin thread is not wound evenly on the bobbin, loosen the nut 4 and turn the bobbin thread tension to adjust the height of the thread tension disk 2.

- It is the standard that the center of the bobbin is as high as the center of the thread tension disk.
- Move the position of the thread tension disk 2 to the direction A as shown in the figure on the left when the winding amount of the bobbin thread on the lower part of the bobbin is excessive and to the direction B as shown in the figure on the left when the winding amount of the bobbin thread on the upper part of the bobbin is excessive.

After the adjustment, tighten the nut 4.

7) Turn the thread tension nut 3 to adjust the tension of the bobbin thread winder.

Note 1. When winding bobbin thread, start winding in the state that the thread between bobbin and thread tension disk 2 is tense.

2. When winding bobbin thread in the state that the sewing is not performed, remove needle thread from the thread path of the thread take-up and remove bobbin from the hook.

5-4. Placing the bobbin case and the bobbin



WARNING :

To protect against possible personal injury due to abrupt start of the machine, be sure to start the following work after turning the power off and ascertaining that the motor is at rest.

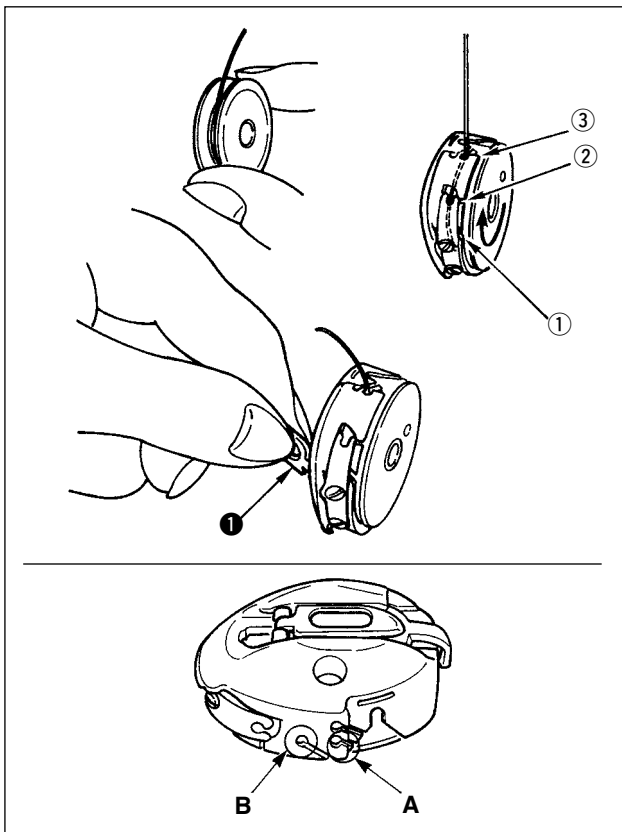

- 1) Turn the handwheel by hand to raise the needle to its highest position.
- 2) Take a bobbin by your right hand with the thread drawn out about 5 cm from the thread end of the bobbin and place it into the bobbin case as illustrated.
- 3) Thread the bobbin case in the order of the numbers and pull it out through the thread path as illustrated. The bobbin rotates in the bobbin case in the direction shown by arrow when bobbin thread is drawn.
- 4) Raise bobbin case latch 1 and hold it between your two fingers as shown in the figure on the left.
- 5) Insert the bobbin case into the sewing hook shaft as far as it will go by putting your hand from the under cover of the inner hook. (Click sounds.)
- 6) Release the bobbin case latch to let it steadily rest in the closing position.

■ How to use the bobbin case thread hole

- 1) Use hole A mainly for zigzag stitches other than 2-step zigzag stitch and scallop zigzag stitch.
- 2) Use hole B mainly for 2-step zigzag stitch and scallop zigzag stitch.



There may be a case where several stitches at the start of sewing are difficult to be knotted when thread trimmer is used with thin filament thread such as (#50, #60 or #80) using hole B. At this time, use the other hole or perform the sewing starting from the right.

5-5. Threading the machine head



WARNING :

To protect against possible personal injury due to abrupt start of the machine, be sure to start the following work after turning the power off and ascertaining that the motor is at rest.

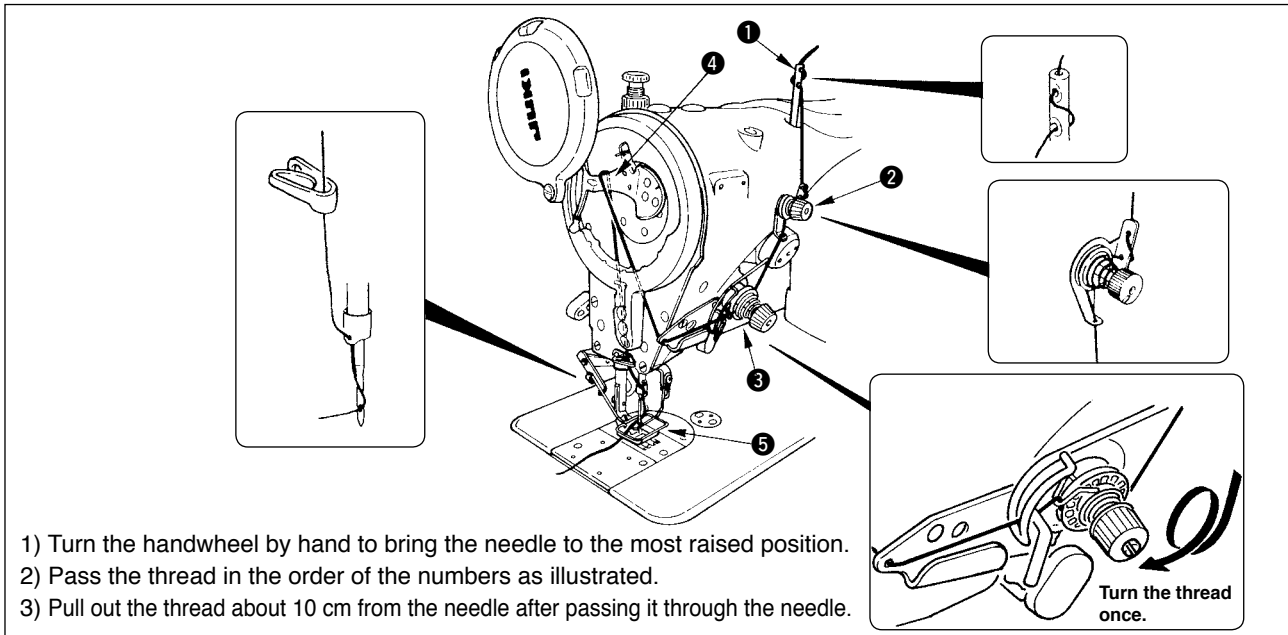

- 1) Turn the handwheel by hand to bring the needle to the most raised position.
- 2) Pass the thread in the order of the numbers as illustrated.
- 3) Pull out the thread about 10 cm from the needle after passing it through the needle.

5-6. Adjusting the stitch length

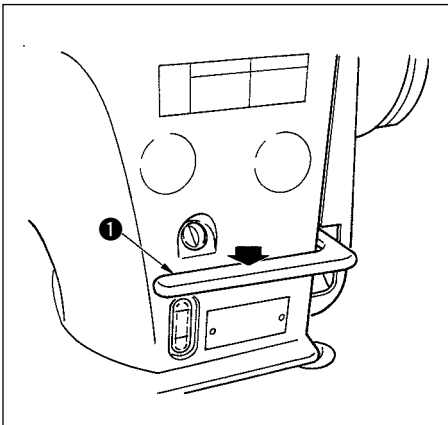

- 1) Adjustment of the stitch length is performed with the operation panel. For the setting procedure of the respective sewing patterns, refer to "6-5. Setting the sewing pattern".

Normal feed : Press +/- keys of to input.

Reverse feed : Press +/- keys of to input.

- 2) Numerical value of the operation panel is indicated in mm.
- 3) When performing the reverse feed stitching, press down reverse feed control lever ①. The sewing machine performs reverse feed stitching as long as you keep the lever held pressed. The reverse feed control lever will return to its home position and the sewing machine will run in the normal stitching direction when you release the reverse feed control lever.

Example) In case of normal feed : +4 and reverse feed : -3, the sewing range becomes normal feed +4 to -3. The maximum amount of reverse feed becomes -3 when reverse feed control lever ① is pressed. Besides, it is possible to adjust the stitch length of normal/reverse feed up to 5 mm at the maximum by inputting.



There may be the cases where the feed amount of the operation panel and the actual sewing pitch are different from each other in case of the use in the state other than the standard delivery or material used. Compensate the pitch in accordance with the sewing product.

5-7. Adjusting the condensation stitching

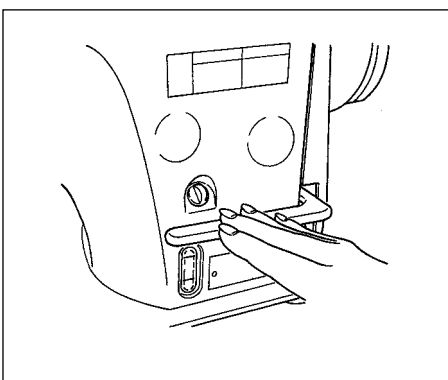

Condensation stitching means that feed pitch amount is reduced and tie stitching is performed by operating the reverse feed control lever at the start or end of sewing.

- 1) Adjustment of the stitch length is performed with the operation panel. Reverse feed : Press +/- keys of to input. Tie stitching can be performed by inputting the reverse feed amount to "0".
- 2) Note that the tie stitching value is mere reference. Adjust the condensation stitching while actually observing the finished seam.
- 3) Numerical value of the operation panel is indicated in mm.







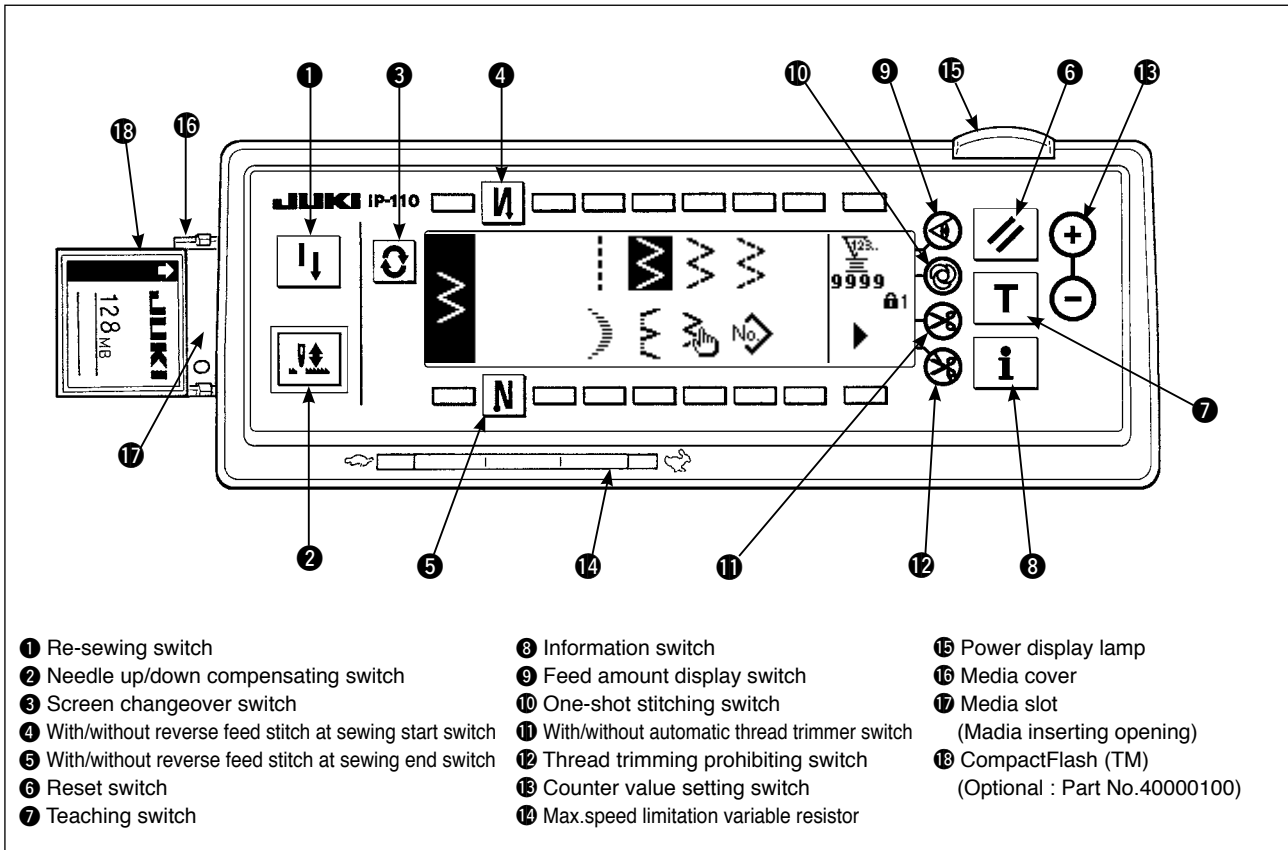

It is possible for the gauge delivered (feed dog part No. : 40018430) to adjust up to 5 mm of normal/reverse feed at the maximum. There is a possibility that material is apt to fall in case of the process where the feed amount is small. Use the gauges such as feed dog and the like in accordance with the process.







6. HOW TO USE THE OPERATION PANEL

6-1. Names and functions of the respective sections

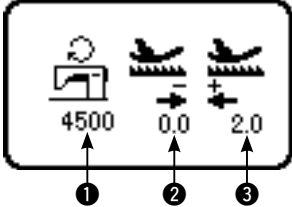

- | | | |
|---|--|-------------------------------|
| ① Re-sewing switch | ⑧ Information switch | ⑬ Power display lamp |
| ② Needle up/down compensating switch | ⑨ Feed amount display switch | ⑭ Media cover |
| ③ Screen changeover switch | ⑩ One-shot stitching switch | ⑮ Media slot |
| ④ With/without reverse feed stitch at sewing start switch | ⑪ With/without automatic thread trimmer switch | (Media inserting opening) |
| ⑤ With/without reverse feed stitch at sewing end switch | ⑫ Thread trimming prohibiting switch | ⑯ CompactFlash (TM) |
| ⑥ Reset switch | ⑬ Counter value setting switch | (Optional : Part No.40000100) |
| ⑦ Teaching switch | ⑭ Max. speed limitation variable resistor | |

<p>① Re-sewing switch</p> 	<p>This switch is used to continue sewing from the step on the way after replacing bobbin thread when bobbin thread has run out during program stitching step.</p>
<p>② Needle up/down compensating switch</p> 	<p>This is the switch to perform needle up/down compensating stitching. (Needle up/down compensating stitching and one stitch compensating stitching can be changed over with function setting No. 22.)</p>
<p>③ Screen changeover switch</p> 	<p>This is the switch to change over the screen.</p>
<p>④ With/without reverse feed stitch at sewing start switch</p> 	<p>This is the switch to turn ON/OFF automatic reverse feed stitch at sewing start. * This switch cannot be used with the sewing machine which is not provided with automatic reverse feed stitching device. For the details, see p. 71.</p>
<p>⑤ With/without reverse feed stitch at sewing end switch</p> 	<p>This is the switch to turn ON/OFF automatic reverse feed stitch at sewing end. * This switch cannot be used with the sewing machine which is not provided with automatic reverse feed stitching device. For the details, see p. 71.</p>
<p>⑥ Reset switch</p> 	<p>This is the switch to make the value of bobbin thread counter or sewing counter the set value. For the details, see p. 96.</p>

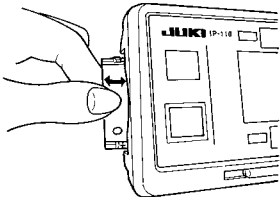
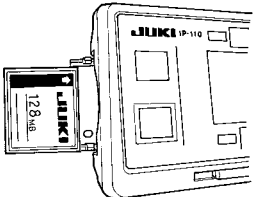
<p>7 Teaching switch</p> 	<p>This is the switch to set the setting of the number of stitches with the value of number of stitches which has been actually sewn.</p>
<p>8 Information switch</p> 	<p>This is the switch to perform various function settings.</p>
<p>9 Feed amount display switch</p> 	<p>Number of rotations, normal feed amount and reverse feed amount of the pattern which is selected at present are displayed.</p>  <p> ① : Number of rotations ② : Reverse feed amount ③ : Normal feed amount </p> <p>* The above amounts are not displayed at the time of cycle stitching.</p>
<p>10 One-shot stitching switch</p> 	<p>When this switch is set to effective at the time of program stitching, the sewing machine automatically operates up to the specified number of stitches.</p>
<p>11 With/without automatic thread trimmer switch</p> 	<p>When this switch is set to effective at the time of program stitching, the sewing machine automatically performs thread trimming when the specified number of stitches has been completed.</p>
<p>12 Thread trimming prohibiting switch</p> 	<p>This switch prohibits all thread trimmings.</p> <p>* This switch cannot be used with the sewing machine which is not provided with the automatic thread trimming device.</p>
<p>13 Counter value setting switch</p> 	<p>This is the switch to set the value of bobbin thread counter or No. of pcs. counter.</p>
<p>14 Max. speed limitation variable resistor</p>	<p>When moving the resistor in the left direction, max. speed is limited.</p>
<p>15 Power display lamp</p>	<p>This lamp lights up when the power switch is turned ON.</p>
<p>16 Media slot cover</p> 	<p>This is the cover for media inserting opening.</p> <p>To open the cover, place your finger on the notch located on the side of the cover as shown in the figure and push the cover in the direction of left slanting rear.</p> <p>* There are some functions that are not able to be operated with the cover opened. Do not close the cover unless the CompactFlash(TM) is completely inserted. For the details, see p.104.</p>
<p>17 Media slot (Media inserting opening)</p> 	<p>To set CompactFlash(TM), place the label face of the CompactFlash(TM) to the front and insert the part that has a small hole (place the notch of the edge to the rear) to the panel.</p> <p>To remove the CompactFlash(TM), hold it between your fingers and draw it out. For the details, see p.104.</p> <p>* When the inserting direction of the CompactFlash(TM) is wrong, the panel and the CompactFlash(TM) may be damaged. Do not insert anything other than the CompactFlash(TM).</p>

6-2. Before setting the pattern

WARNING :

- When using presser foot, throat plate and feed dog other than those delivered as standard, needle may come in contact with throat plate and breaks, or feed dog may come in contact with throat plate in case of some set values. Be sure to perform the regulation of limitation values of ❶, ❸ and ❹ in accordance with the gauge used. The regulation at the time of delivery is as follows :
 Max. zigzag width : 8 mm
 Max. feed amount : 5 mm
- When replacing the gauge, provide a clearance of 0.6 mm or more between needle, and presser foot and throat plate, and between throat plate and feed dog.

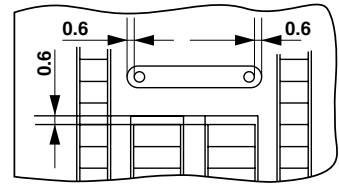

(1) Limitation of the max. zigzag width

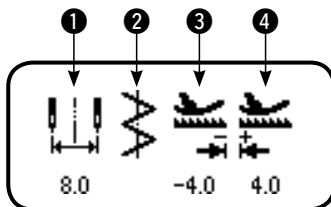

Max. zigzag width limitation value, reference of stitch base line, normal feed amount limitation value and reverse feed amount limitation value are displayed when the power is turned ON.

- ❶ : Max. zigzag width limitation value (Screen changes in case of specifying left/right positions.)
- ❷ : Reference of stitch base line
- ❸ : Max. reverse feed amount limitation value
- ❹ : Max. normal feed amount limitation value

Display of max. zigzag width limitation value, reference of stitch base line, normal feed amount limitation value and reverse feed amount limitation value can be performed with ON/OFF.



- Max. zigzag width can be limited in accordance with the gauge.
- There are two kinds of limitations of max. zigzag width.
 - Zigzag width symmetrical in the center
 - Specifying left/right positions

Changeover of limiting procedure of max. zigzag width limitation value

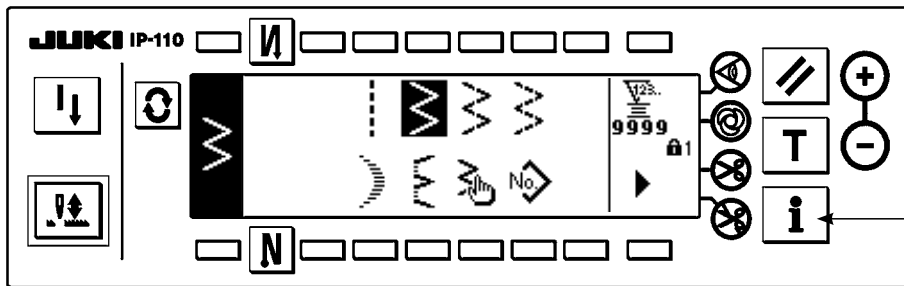

1) Press switch ❶.

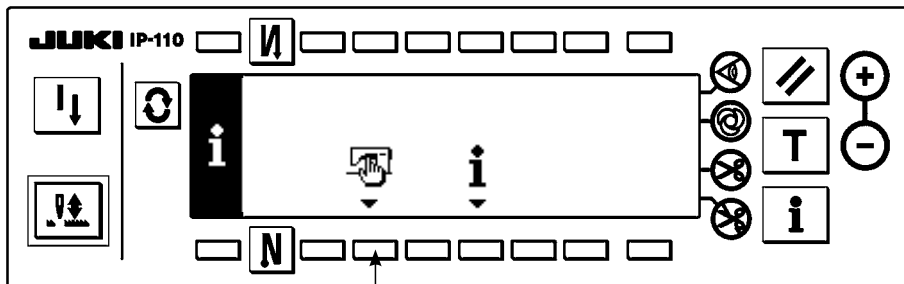

2) Press switch ❷.

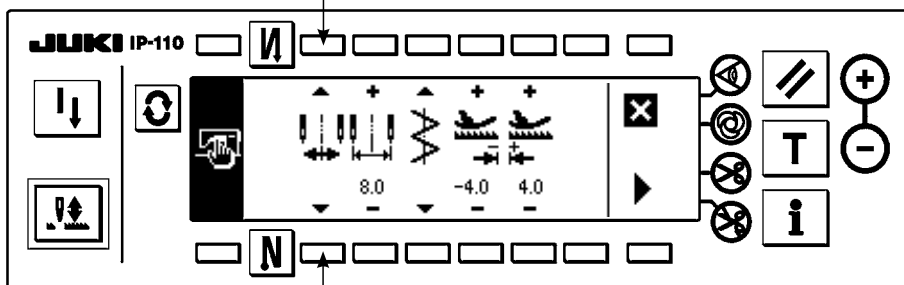

3) Figure on the left side is the zigzag width symmetrical in the center mode.

Every time switch ❸ is pressed, specifying left/right positions and zigzag width symmetrical in the center can be changed over alternately.

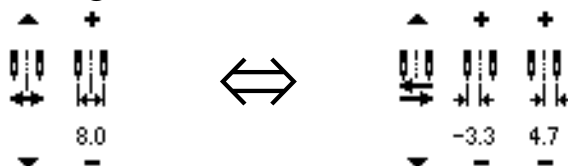

(1) Zigzag width symmetrical in the center

(2) Specifying left/right positions

■ How to set max. zigzag width limitation value

Determine whether limitation of zigzag width symmetrical in the center or limitation of left/right positions in the order of 1) to 3) of the previous page in accordance with the gauge used.

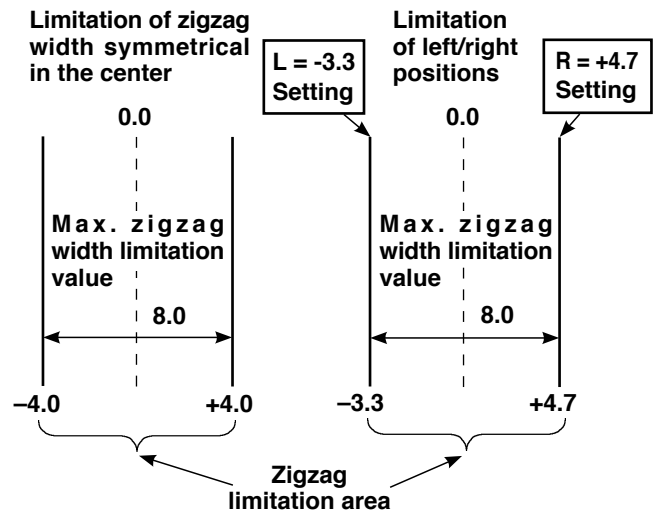

(A) In case of zigzag width symmetrical in the center

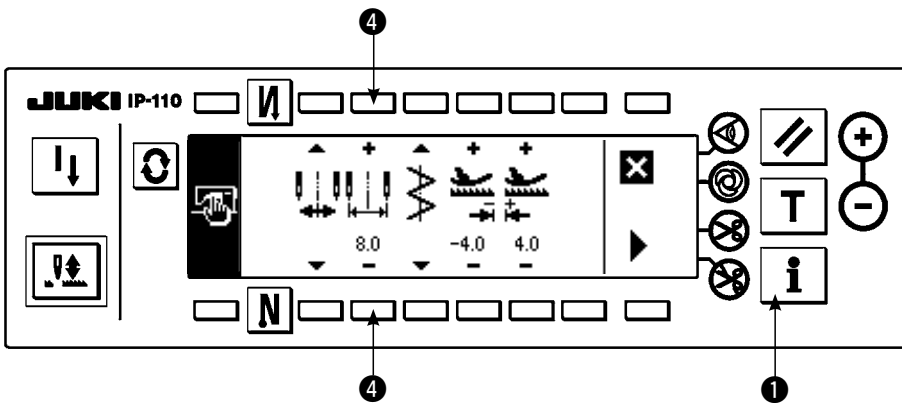

- 1) Press +/- of switch ④ and set the limitation value. In case of the example, set the value to 8.0.
- 2) Press switch ① and the screen returns to the previous one.

(B) In case of specifying left/right positions

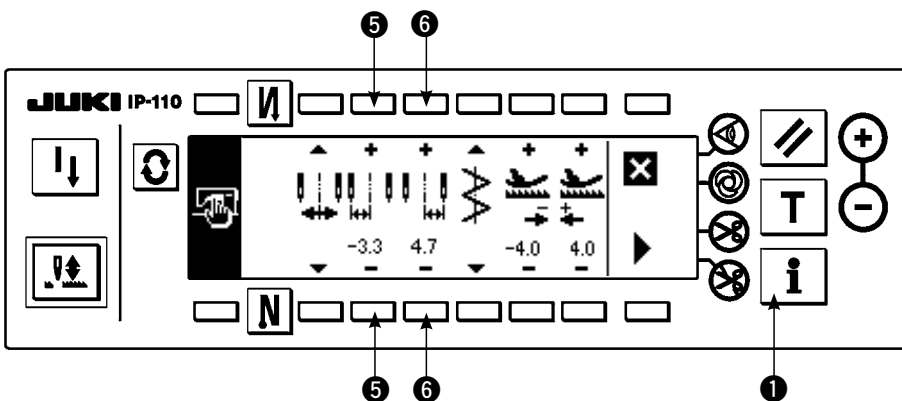

Change of left side position limitation

- 1) Press +/- of switch ⑤ to set the left side limitation value.

In case of the example, set the value to -3.3.

Change of right side position limitation

- 2) Press +/- of switch ⑥ to set the right side limitation value.

In case of the example, set the value to +4.7.

- 3) Press switch ① and the screen returns to the previous one.

(2) Setting the reference of stitch base line

- Reference position of stitch base line can be set to left, center and right.

Reference of left
stitch base line

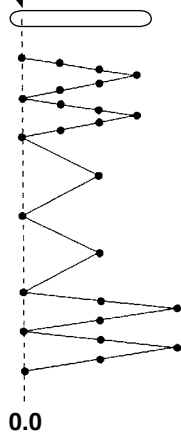

Reference of center
stitch base line

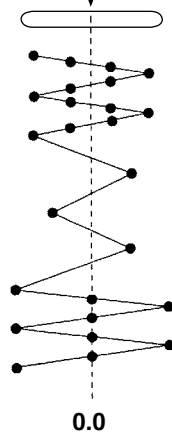

Reference of right
stitch base line

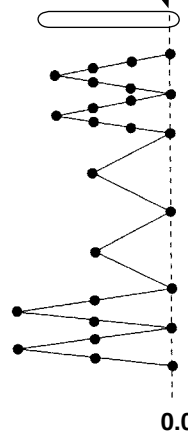

How to set

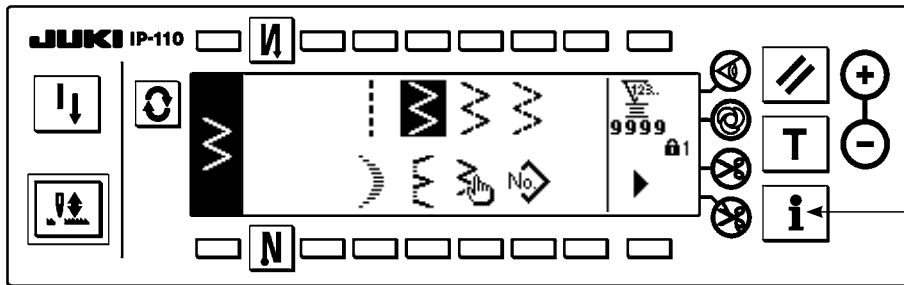

- 1) Press switch ❶.

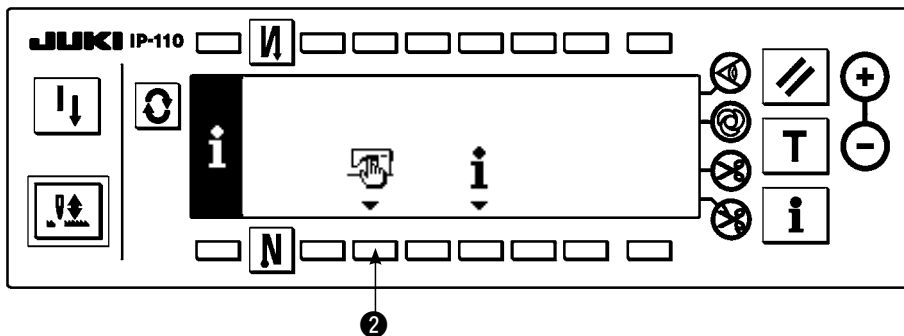

- 2) Press switch ❷.

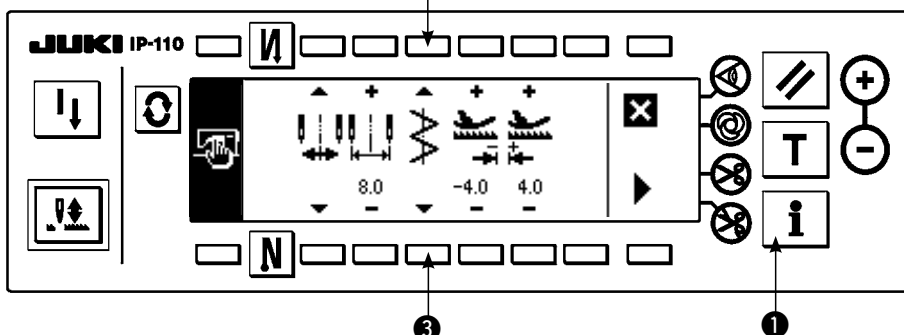

- 3) Figure on the left side shows the reference of center stitch base line. Every time switch ❸ is pressed, reference of left stitch base line, that of right stitch base line and that of center stitch base line are changed over and set alternately.

- 4) Press switch ❶ and the screen returns to the previous one.



Reference of left
stitch base line



Reference of center
stitch base line



Reference of right
stitch base line

(3) Setting the feed amount

- Max. possible setting range in the normal direction and max. possible setting range in the reverse direction can be set in accordance with the gauge used.

■ Setting procedure

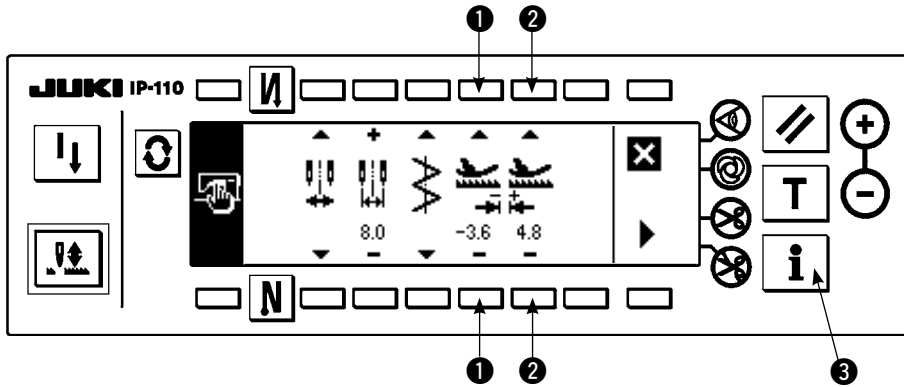

Change in the reverse direction

- 1) Press +/- of switch ① to set the limitation value in the reverse direction.

In case of the example, the feed amount is -3.6.

Change in the normal direction

- 2) Press +/- of switch ② to set the limitation value in the normal direction.

In case of the example, the feed amount is +4.8.

- 3) When switch ③ is pressed, the screen returns to the previous one.



Level of the standard delivery of key lock is "1". To perform all settings, it is necessary to set the key lock to level "0". For the details, see p.102.

6-3. Basic screen

The screen after turning ON the power source becomes the screen at the time of turning OFF the power source for the last time.

Every time  switch is pressed, the screen changes as follows :

Example) Free stitching of 2-step zigzag with reverse feed stitching (Contents of display change depending on the set values.)

■ Sewing shape list first screen

Selection of each shape is performed.

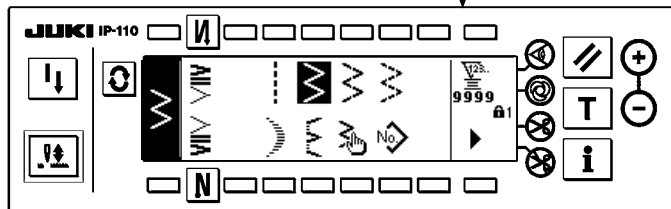

Press .

Press .

Press .

■ Sewing shape list second screen

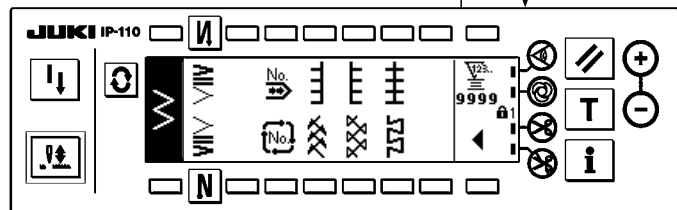

* Free stitching means the general sewing.

■ Sewing shape setting first screen

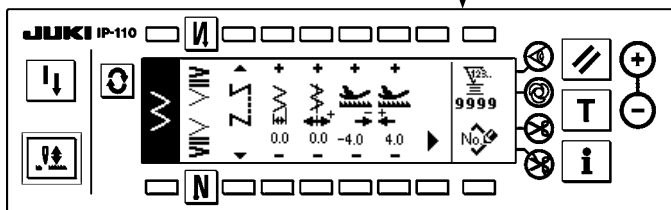

Press .

Press .

Press .

■ Sewing shape setting second screen

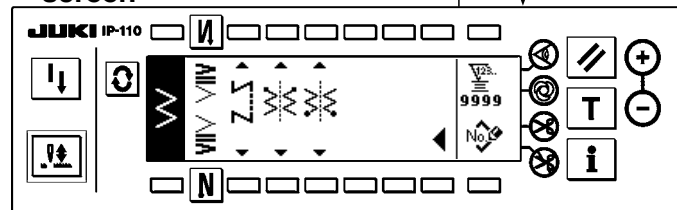

■ Reverse feed stitching setting screen

Setting of kind of condensation, number of stitches, etc. is performed.

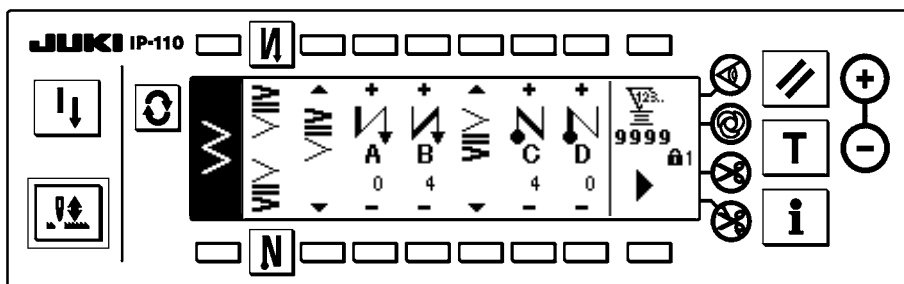

Press .



When  is pressed for approximately three seconds in a screen other than the sewing shape list screen, the screen directly transits to the sewing shape list screen.

6-4. List of the display pictographs of each screen

■ Sewing shape list first screen

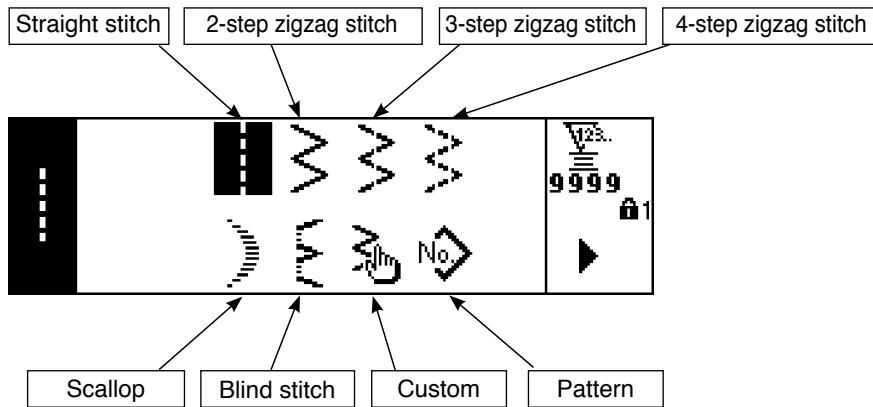

■ Sewing shape list second screen

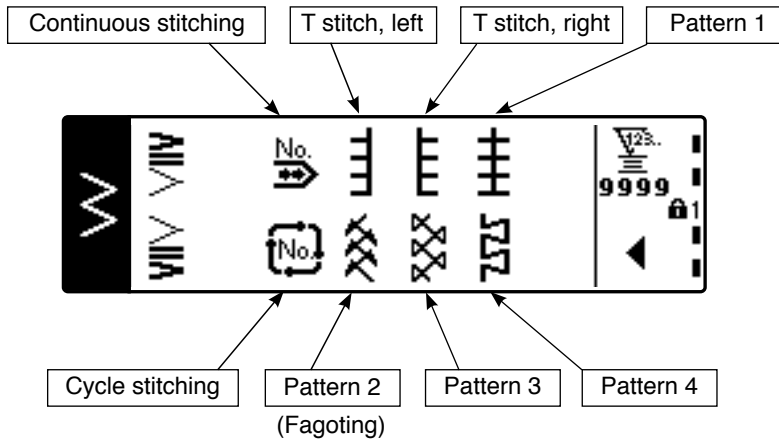

■ Scallop selection pop-up screen

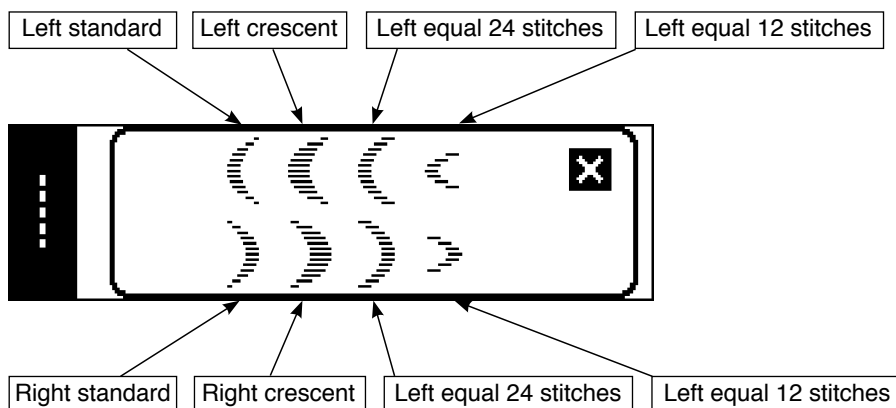

■ Blind stitch selection pop-up screen

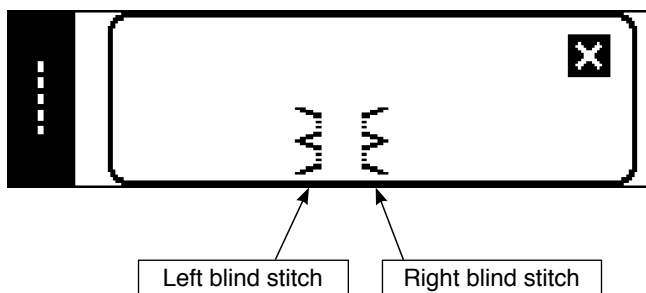

■ Custom pattern selection pop-up screen

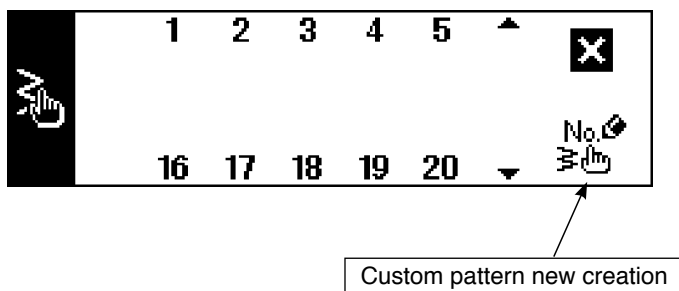

■ Pattern stitching selection pop-up

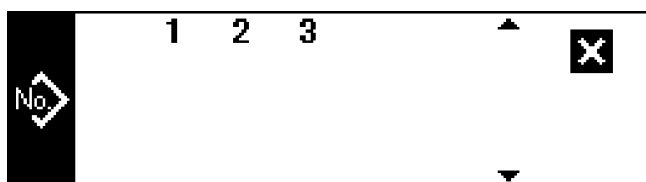

■ Continuous stitching selection pop-up screen

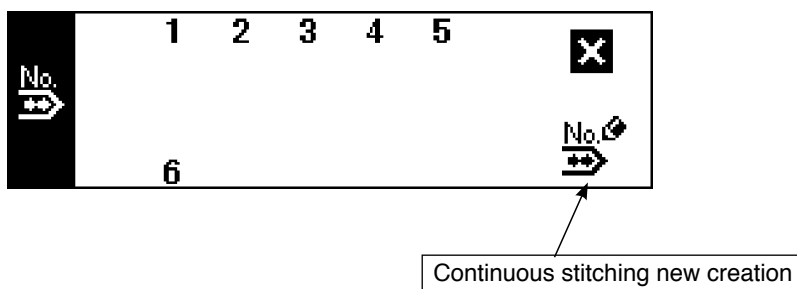



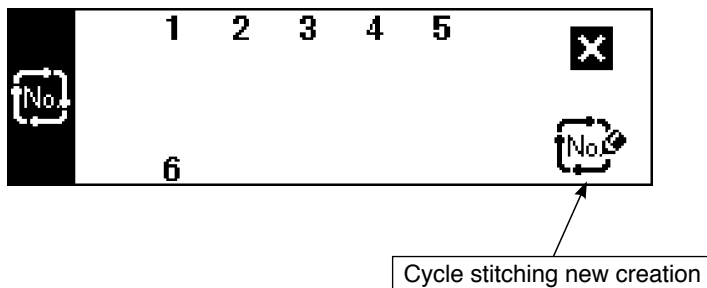



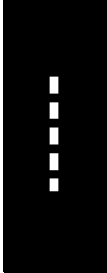

■ Cycle stitching selection pop-up screen





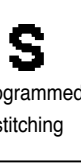







The key lock level has been set to "1" at the time of delivery, and pictographs of new creation are not displayed. When performing new creation in each mode, change the key lock level to "0". (Refer to the second screen of sewing common data setting of (1) Sewing common data of 6-16. Information.) In addition, the display of pattern No. at the time of delivery is "1" only.

■ Straight stitch sewing shape setting screen

	Kind of sewing	Position of stitch base line	Reverse feed amount	Normal feed amount	
	 Zigzag	 0.0	 -4.0	 4.0	
	 Free stitching				
	 Programmed stitching	-5.0 to 5.0	-5.0 to 5.0	-5.0 to 5.0	
	 Overlapped stitching				

Pattern register

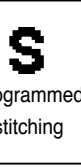









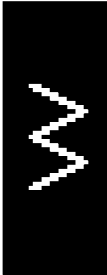









■ 2-step zigzag, 3-step zigzag, and 4-step zigzag stitch sewing shape first screen

	Kind of sewing	Zigzag width	Position of stitch base line	Reverse feed amount	Normal feed amount	
	 Zigzag	 0.0	 0.0	 -4.0	 4.0	
	 Free stitching					
	 Programmed stitching	0 to 10.0	-5.0 to 5.0	-5.0 to 5.0	-5.0 to 5.0	
	 Overlapped stitching					

Pattern register

Second screen display











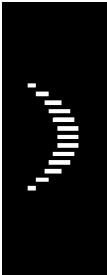



■ 2-step zigzag, 3-step zigzag, and 4-step zigzag stitch sewing shape second screen

	Kind of sewing	Position at sewing start	Position at sewing end		
	  	  	  		
	Free stitching	Optional	Optional		
	 Programmed stitching	 Right	 Right		
	 Overlapped stitching	 Left	 Left		

Pattern register

First screen display







■ Scallop sewing shape setting first screen

	Kind of sewing	Zigzag width	Position of stitch base line	Reverse feed amount	Normal feed amount		
	  	 0.0	 0.0	 -4.0	 4.0		
	Free stitching						
	 Programmed stitching	0 to 10.0	-5.0 to 5.0	-5.0 to 5.0	-5.0 to 5.0		
 Overlapped stitching							

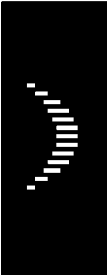
Pattern register

Second screen display

■ Scallop sewing shape setting second screen











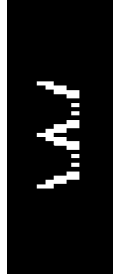





	Kind of sewing	Position at sewing start Root · Crest	Position at sewing end Right · Left	Stop position
				
	Free stitching	Root	Optional	Optional
	Programmed stitching	Crest		Root
	Overlapped stitching			
				











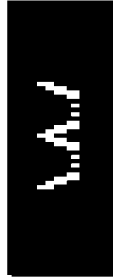

Pattern register

* Stop position is displayed when the position at sewing end is optional.



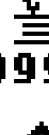







■ Blind stitch sewing shape setting first screen

	Kind of sewing	Zigzag width	Position of stitch base line	Reverse feed amount	Normal feed amount	
	  Zigzag stitching Free stitching	  Zigzag width 0.0	  Position of stitch base line 0.0	  Reverse feed amount -4.0	  Normal feed amount 4.0	  Pattern register 123. 9999  No.
	 Free stitching					
	 Programmed stitching	0	-5.0	-5.0	-5.0	
	 Overlapped stitching	to 10.0	to 5.0	to 5.0	to 5.0	

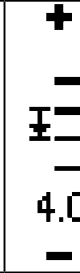



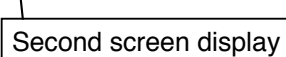

■ Blind stitch sewing shape setting second screen

	Kind of sewing	Number of stitches	
	  Zigzag stitching Free stitching	  Number of stitches 4	  Pattern register 123. 9999  No.
	 Free stitching		
	 Programmed stitching	3	
	 Overlapped stitching	to 250	

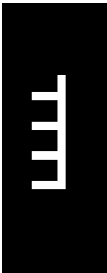
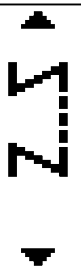
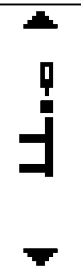



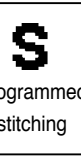





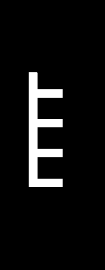



















■ T stitch, left sewing shape setting first screen

	Kind of sewing	Zigzag width	Position of stitch base line	Compensation value	Normal feed amount	
	 Zigzag sewing	 0.0	 0.0	 -4.0	 4.0	 9999 No.
	 Free stitching					 Pattern register  Second screen display
	 Programmed stitching	0 to 10.0	-5.0 to 5.0	-5.0 to 5.0	-5.0 to 5.0	
	 Overlapped stitching					

■ T stitch, left sewing shape setting second screen

	Kind of sewing	Position at sewing start	Position at sewing end	
	 Zigzag sewing	 Left	 Left	 9999 No.
	 Free stitching	Left	Left	 Pattern register
	 Programmed stitching	Right 1	Right 1	
	 Overlapped stitching	Right 2	Right 2	
 Optional	Optional	Optional		











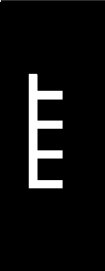









■ T stitch, right sewing shape setting first screen

	Kind of sewing	Zigzag width	Position of stitch base line	Compensation value	Normal feed amount	
	    	    	    	    	    	
	Free stitching					
	Programmed stitching	0 to 10.0	-5.0 to 5.0	-5.0 to 5.0	-5.0 to 5.0	
	Overlapped stitching					

Pattern register







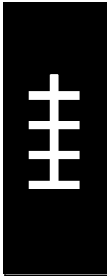

Second screen display

■ T stitch, right sewing shape setting second screen

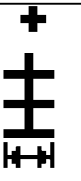
	Kind of sewing	Position at sewing start	Position at sewing end	
	    	    	    	
	Free stitching	Right 1	Right 1	
	Programmed stitching	Left 1	Left 1	
	Overlapped stitching	Right 2	Right 2	
Optional		Optional		

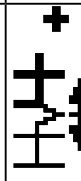
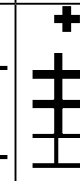
Pattern register







■ Pattern 1 sewing shape setting first screen

	Kind of sewing	Zigzag width	Position of stitch base line	Compensation value	Normal feed amount	
	  Free stitching	 0.0	 0.0	 -4.0	 4.0	
	 Free stitching					
	 Programmed stitching	0	-5.0	-5.0	-5.0	
	 Overlapped stitching	to 10.0	to 5.0	to 5.0	to 5.0	

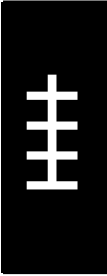

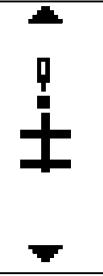

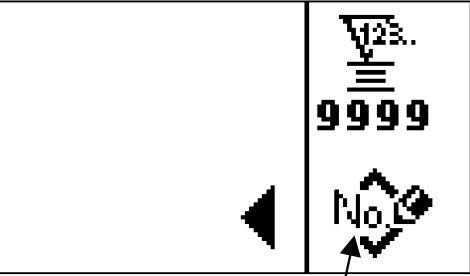





Pattern register

Second screen display

■ Pattern 1 sewing shape setting second screen

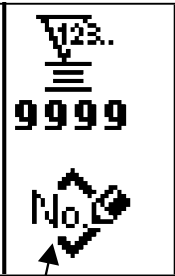
	Kind of sewing	Position at sewing start	Position at sewing end	
				
	Free stitching	Center 1	Center 1	
	Programmed stitching	Center 2	Center 2	
		Left	Left	
Center 3		Center 3		
		Right	Right	
		Optional	Optional	

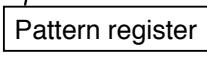
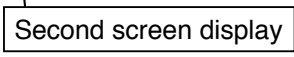
■ Pattern 2 (fagoting) sewing shape setting first screen













	Kind of sewing	Zigzag width	Position of stitch base line	Reverse feed amount	Normal feed amount	
		 0.0	 0.0	 -4.0	 4.0	
	 Free stitching					 
	 Programmed stitching	0	-5.0	-5.0	-5.0	
	 Overlapped stitching	to 10.0	to 5.0	to 5.0	to 5.0	

■ Pattern 2 sewing shape setting second screen

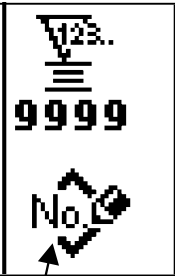
	Kind of sewing	Position at sewing start	Position at sewing end	
	Free stitching	Right 1	Right 1	
	Programmed stitching	Center 1	Center 1	
	Overlapped stitching	Left1	Left1	
Left2		Left2		
		Center 2	Center 2	
		Right 2	Right 2	
	Optional	Optional	Optional	

* Position at the sewing start is set with ▲ / ▼ of switch ⑥.







■ Pattern 3 sewing shape setting first screen

	Kind of sewing	Zigzag width	Position of stitch base line	Reverse feed amount	Normal feed amount	
	 	 0.0	 0.0	 -4.0	 4.0	
	 Free stitching					  
	 Programmed stitching	0	-5.0	-5.0	-5.0	
	 Overlapped stitching	to 10.0	to 5.0	to 5.0	to 5.0	





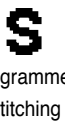



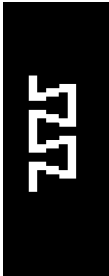

Pattern register

Second screen display

■ Pattern 3 sewing shape setting second screen

	Kind of sewing	Position at sewing start	Position at sewing end	
				
	Free stitching	Right 1	Right 1	
	Programmed stitching	Center 1	Center 1	 <div data-bbox="1082 607 1289 651" style="border: 1px solid black; padding: 2px;">Pattern register</div>
		Overlapped stitching	Left 1	
		Left 2	Left 2	
	Center 2	Center 2		
	Right 2	Right 2		
	Optional	Optional		







■ Pattern 4 sewing shape setting first screen

	Kind of sewing	Zigzag width	Position of stitch base line	Reverse feed amount	Normal feed amount	
		 0.0	 0.0	 -4.0	 4.0	
	 Free stitching					
	 Programmed stitching	0 to 10.0	-5.0 to 5.0	-5.0 to 5.0	-5.0 to 5.0	
	 Overlapped stitching					

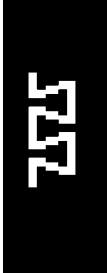
Pattern register

Second screen display

■ Pattern 4 sewing shape setting second screen

	Kind of sewing	Position at sewing start	Position at sewing end	
				
	Free stitching	Left1	Left1	  <div data-bbox="1086 600 1294 645" style="border: 1px solid black; padding: 2px;">Pattern register</div>
	Programmed stitching	Left2	Left2	
	Overlapped stitching	Right 1	Right 1	
		Right 2	Right 2	
	Right 3	Right 3		
	Left3	Left3		
	Optional	Optional		

■ Custom pattern sewing shape setting screen

	Kind of sewing	Zigzag width	Position of stitch base line	Custom Pattern needle entry image	
		 0.0	 0.0		 9999 No.
	Free stitching	0	-5.0		 Pattern register Copy Deletion
	Programmed stitching	to 10.0	to 5.0		
	Overlapped stitching				

■ Custom pattern edit screen

	Step	Zigzag position input	Feed amount per stitch	Custom pattern needle entry image	Last needle entry input
	+	+	+		
	1	0.0	0.0		
	1	-5.0	-5.0		
	to 500	to 5.0	to 5.0		

■ Pattern sewing shape setting screen

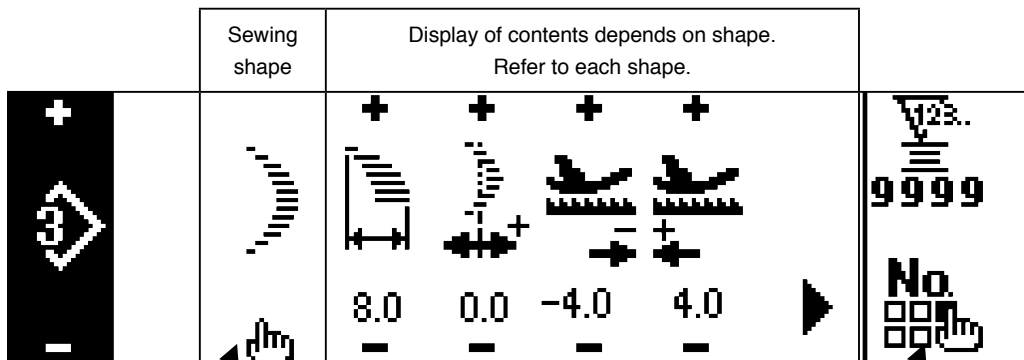

- Selection of sewing shape
- Straight stitch
 - 2-step zigzag stitch
 - 3-step zigzag stitch
 - 4-step zigzag stitch
 - Scallop (8 kinds)
 - Blind stitch (Right and Left)
 - Custom pattern
 - T stitch, left
 - T stitch, right
 - Pattern 1
 - Pattern 2
 - Pattern 3
 - Pattern 4

Copy and deletion screen

No.

Copy

Deletion

■ Continuous stitching setting screen

	Zigzag width	Position of stitch base line	Step	Pattern No.	Number of stitches	
	 4.0	 0.0	 1	 3	 500	

Edit screen display

Copy and deletion screen

No.

Copy

Deletion

■ Continuous stitching edit screen

	Step	Pattern No.	Sewing shape	Number of stitches	
	+	+		+	
	S	3		500	
	1				
	-	-		-	
	1	1		1	
	to	to		to	
	20	99		500	

Determination

* For the sewing shape, the shape which has been registered in the pattern is displayed.

■ Cycle stitching setting screen

	Step	Pattern No.	Number of stitches	Stop state	Position of presser foot	
	+	+				
	S	3	500			
	1					
	-	-				

Edit screen display

Copy and deletion screen

Copy

Deletion

* Stop state is not displayed when the number of stitches is (0 stitch).

* Position of presser foot is displayed except the case where the number of stitches is (0 stitch) with the auto-lifter.

* Presser lifting time is displayed when the position of presser foot is UP stop.

■ Cycle stitching edit screen

	Step	Pattern No.	Number of stitches	Stop state	Position of presser foot	Presser lifting time	
	+	+	+			+	
	S	3	123				
	1	-	500			60.0	
	-	-	-			-	
				 Needle DOWN stop	 Presser foot UP stop		
	1	1	(0 stitch)			0.1	
	to	to	to			to	
	20	*	500	Thread trimming	Presser foot DOWN stop	99.9	
				 Needle UP stop			

Determination

* Stop state is not displayed when the number of stitches is (0 stitch).

* Position of presser foot is displayed except the case where the number of stitches is (0 stitch) with the auto-lifter.

* Presser lifting time is displayed when the position of presser foot is UP stop.

■ Reverse stitching setting first screen

	Reverse stitching at sewing start With/without	Sewing start			Sewing end			
		Selection of kind	Process A	Process B	Selection of kind	Process C	Process D	
	Reverse stitching at sewing end With/without	Normal	0 to 19	0 to 19	Normal	0 to 19	0 to 19	
		 20 Custom	 		 20 Custom	 		
	 2-point	0 to 19	0 to 19	 2-point	0 to 19	0 to 19		

■ Reverse stitching setting second screen (2-point condensation)

	Reverse stitching at sewing start With/without	Width adjustment at sewing start	Width adjustment at sewing end	Reverse Feed amount	Max. number of rotations	
				 0.0	 4.0	
		0.0	0.0	-5.0	200	
		to	to	to	to	
		-5.0	-5.0	5.0	5,000	

* Feed amount is displayed only when custom pattern sewing or continuous stitching is performed.

■ Reverse stitching setting second screen (Condensation custom)

		Width adjustment at sewing start	Width adjustment at sewing end	Reverse Feed amount	Max. number of rotations		
		 4.0	 0.0	 4.0	 4500		
		0.0	0.0	-5.0	200		
		to	to	to	to		
		10.0	10.0	5.0	5,000		

* Feed amount is displayed only when custom pattern sewing or continuous stitching is performed.

■ Sewing common data setting first screen (When max. zigzag width limitation is set in the center)

		Limiting procedure of max. zigzag width limitation	Max. zigzag width limitation value	Reference of stitch base line	Reverse feed amount limitation value	Normal feed amount limitation value		
			8.0		 -4.0	 4.0		
		Center	0.0	Center	0.0	0.0		
			to	Left	to	to		
			10.0	Right	10.0	10.0		
		 LeftRight						

*When the limiting procedure of max. zigzag width limitation is set to “Left/Right”, the display of max. zigzag width limitation value is separately indicated left and right.

■ Sewing common data setting first screen

(When limiting procedure of max. zigzag width limitation is set to left/right)

	Limiting procedure of max.zigzag width limitation	Specifying left position	Specifying right position	Reference of stitch base line	Reverse feed amount limitation value	Normal feed amount limitation value	
		 -3.3	 4.7		 -4.0	 4.0	
	 Left/Right	-5.0 to 0.0	0.0 to 5.0	 Center Left Right	-5.0 to 5.0	-5.0 to 5.0	
	 Center						

* When the limiting procedure of max. zigzag width limitation is set to “Center”, the display of max. zigzag width limitation value becomes that of symmetrical in the center.

■ Sewing common data setting second screen

	Mirror function setting	Condensation custom stitch base line	Counter function	Key lock	Max.zigzag width limitation when turning ON the power	
	 1 pattern	 Interlocking	 ON	 Level 1	 Display	
	 Continuous	 Fixed	 OFF	 OFF Level 2	 Non-display	

6-5. Setting the sewing pattern



WARNING :

Be sure to check presser foot and gauge currently being used before sewing after changing the zigzag pattern or zigzag width. In case where sewing is performed with the presser foot or gauge not matching the zigzag width, it is in danger of accident such as needle breakage or the like.

(1) Selecting the zigzag pattern

- ① : When ► is pressed, the second screen is displayed.
- ② : When ◀ is pressed, the first screen is displayed.

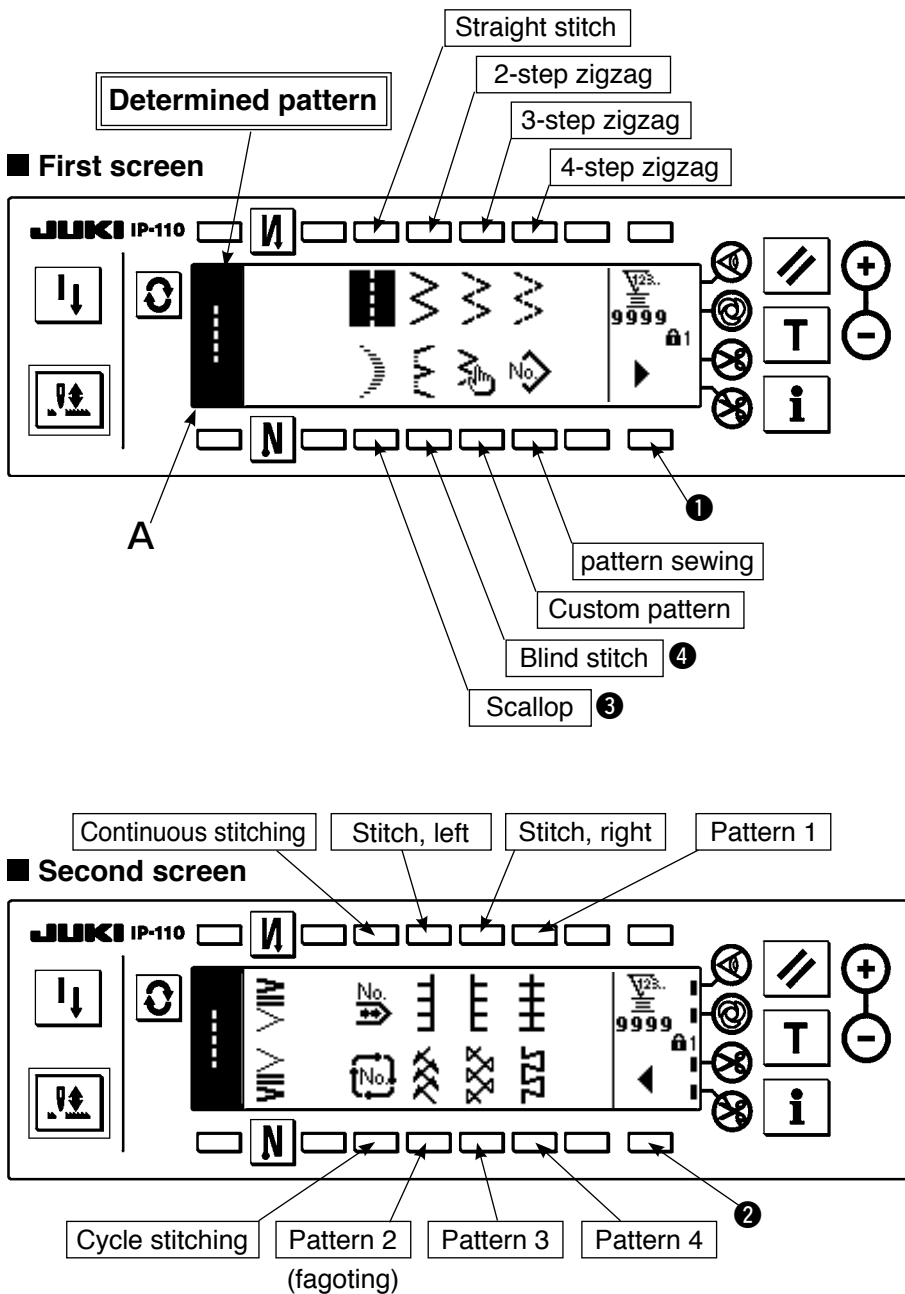

- 1) Select the zigzag pattern you desire to sew with the selection switch when the figure above is in the screen. The determined pattern is displayed in section A.
- 2) For scallop and blind stitch, select the shape with the next screen.

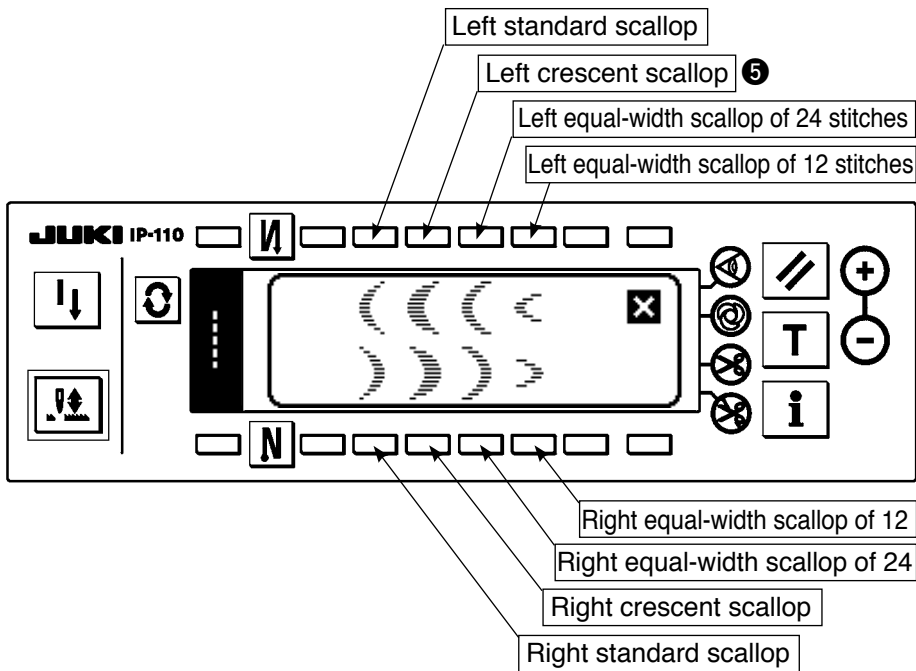

In case of the scallop

1) Press scallop 5 and the screen on the left side appears.

Press the pattern switch you desire to select.

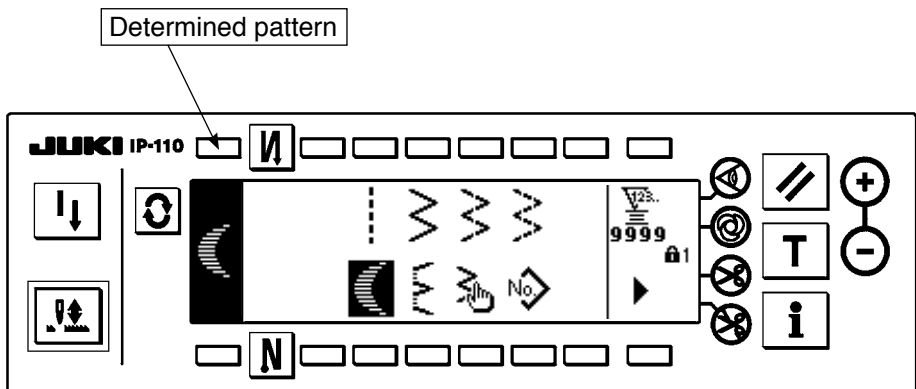

2) As an example, press left crescent scallop 5 and the screen on the left side appears to determine the pattern.

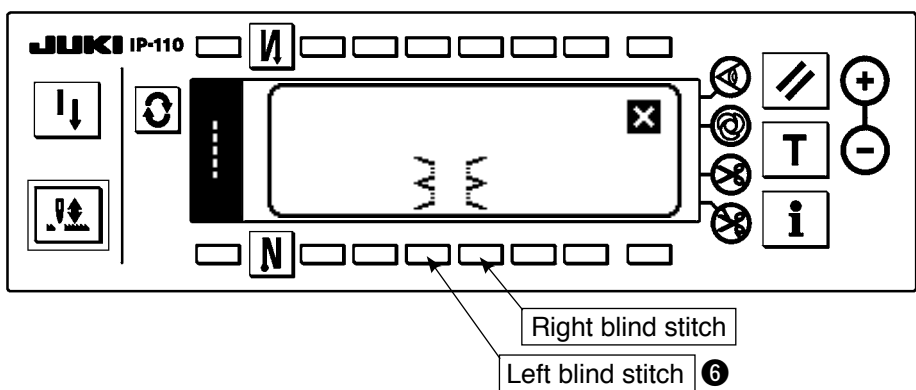

In case of the blind stitch

1) Press blind stitch 6 and the screen on the left side appears.

Press the pattern switch you desire to select.

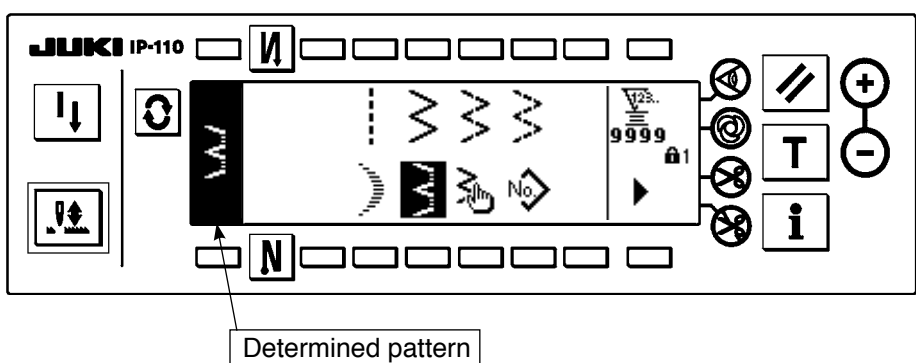

2) As an example, press left blind stitch 6 and the screen on the left side appears to determine the pattern.

6-6. Setting of the sewing shape

- Zigzag width can be set from “0” to 10 mm. (Set value is limited by the max.zigzag width limitation.)
- Stitch base line can be set as follows. When the center of zigzag is “0.0”, Right side : “+” Left side : “-”.

(1) 2-step zigzag, 3-step zigzag and 4-step zigzag stitch

■ Sewing shape list first screen

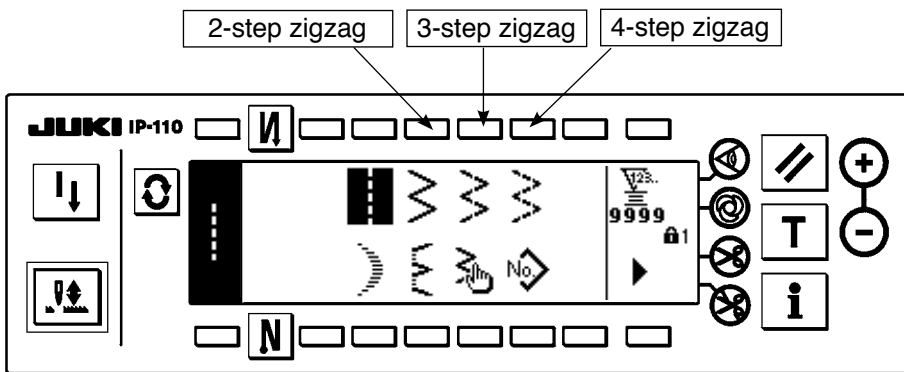

- 1) Select 2-step (3-step or 4-step) zigzag stitch in the sewing shape list first screen.
- 2) The selected shape reverses and is displayed on the left end of the screen.
- 3) Press  to display the sewing shape setting screen.

■ Sewing shape setting screen

● First screen

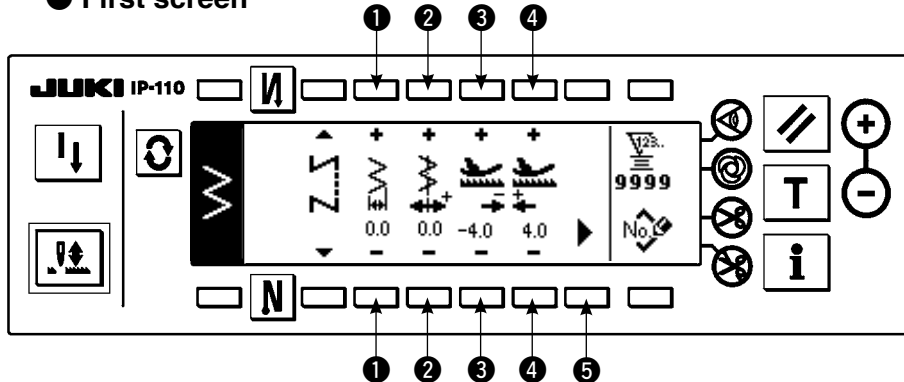

● Second screen

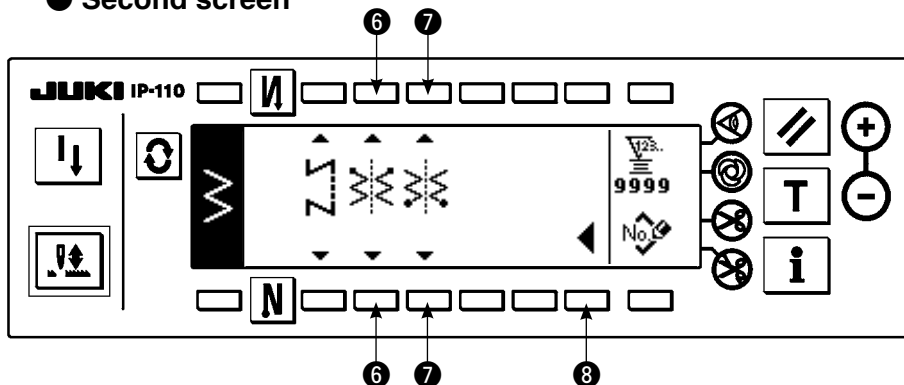

- **Setting of the zigzag width**

Change the zigzag width with +/- of switch ①.

- **Setting of the position of stitch base line**

Change the position of stitch base line with +/- of switch ②.

- **Setting of the reverse feed amount**

Change the reverse feed amount with +/- of switch ③.

- **Setting of the normal feed amount**

Change the normal feed amount with +/- of switch ④.

- **Display of the second screen**

Display the sewing shape setting second screen with switch ⑤.

- **Setting of the position of sewing start**

Set the position of sewing start with ▲/▼ of switch ⑥.



Sewing start



Optional Sewing start



Right Sewing start, left

- **Setting of the stop position**

Set the stop position with ▲/▼ of switch ⑦.



Stop position, optional



Stop position, right



Stop position, left

- **Display of the first screen**

Display the sewing shape setting first screen with switch ⑧.

(2) Scallop stitching

■ Sewing shape list first screen

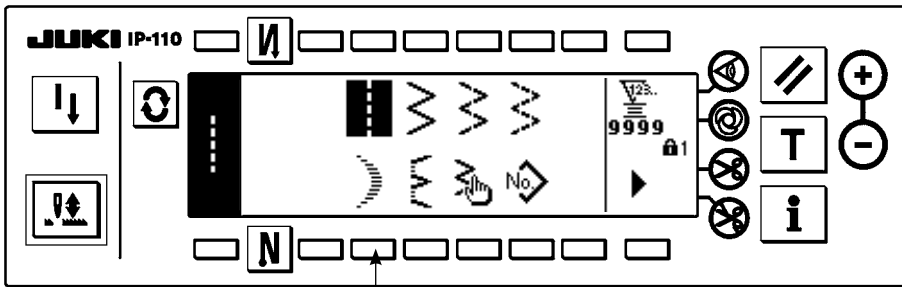

- 1) Select scallop stitching ❶ in the sewing shape list first screen.

■ Scallop selection pop-up screen

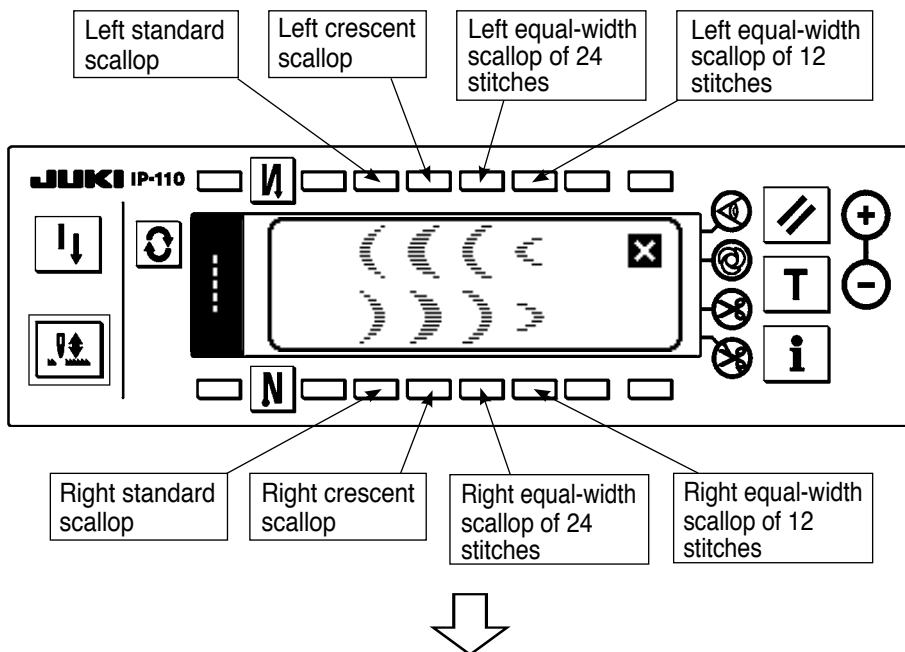

- 2) Press the switch of pattern to be selected from the screen of the left figure.

■ Sewing shape list first screen

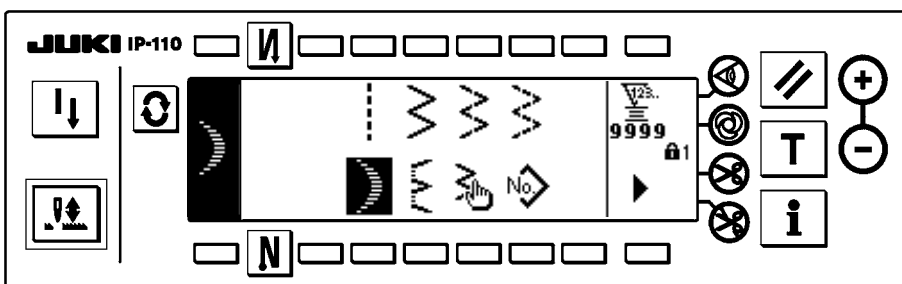

- 3) The selected shape reverses and is indicated on the left end of the screen.
- 4) Press  to display the sewing shape setting screen.

■ Sewing shape setting screen

● First screen

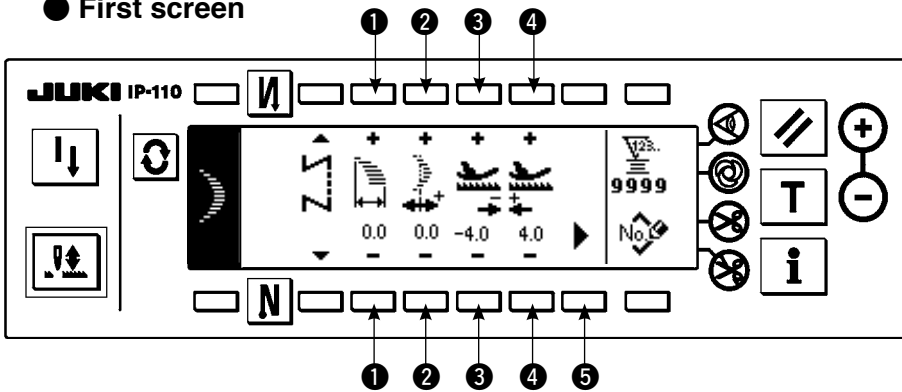

● Second screen

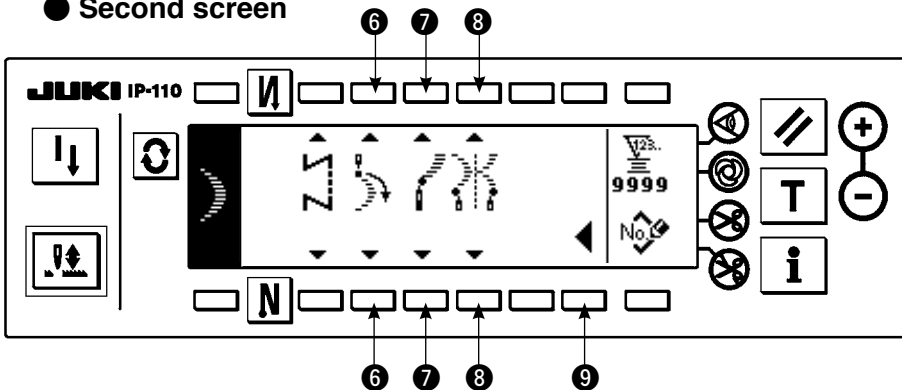

● Setting of the zigzag width

Change the zigzag width with +/- of switch ①.

● Setting of the position of stitch base line

Change the position of stitch base line with +/- of switch ②.

● Setting of the reverse feed amount

Change the reverse feed amount with +/- of switch ③.

● Setting of the normal feed amount

Change the normal feed amount with +/- of switch ④.

● Display of the second screen

Display the sewing shape setting second screen with switch ⑤.

● Setting of the position of sewing start

Set the position of sewing start with ▲ / ▼ of switch ⑥.

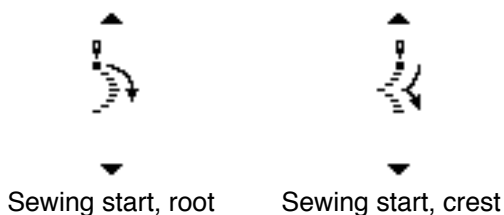

● **Start from crest and start from root of scallop**

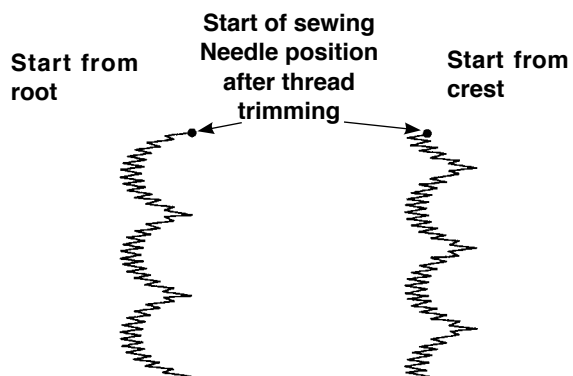

Normally, scallop starts the sewing with the pattern of start from root. However, start from crest can be selected by changing the setting.

● **Setting of the stop position right/left**

Set the stop position with ▲ / ▼ of switch ⑦.



Stop position, optional



Stop position, right



Stop position, left

● **Setting of the stop position**

Set the stop position with ▲ / ▼ of switch ⑧.



Stop position, optional



Stop position, root

● **Display of the first screen**

Display the sewing shape setting first screen with switch ⑨.



For the mirror sewing, refer to P.126.

(3) Blind stitch sewing

■ Sewing shape list first screen

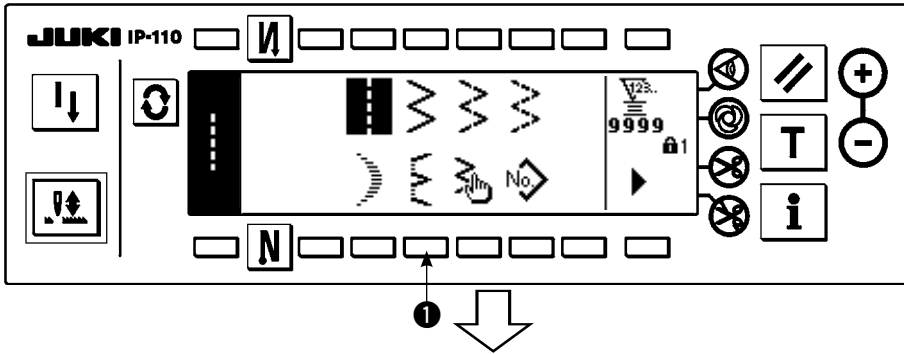

- 1) Select the blind stitch sewing in the sewing shape list first screen.

■ Blind stitch selection pop-up screen

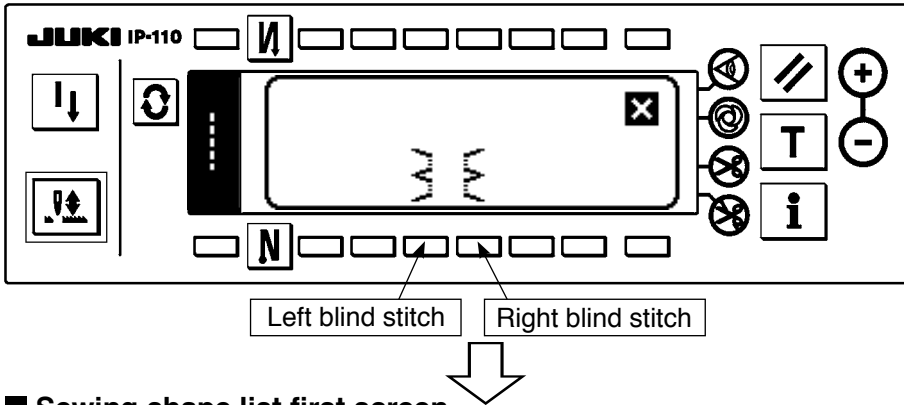

- 2) Press the switch of pattern to be selected from the screen of the left figure.

■ Sewing shape list first screen

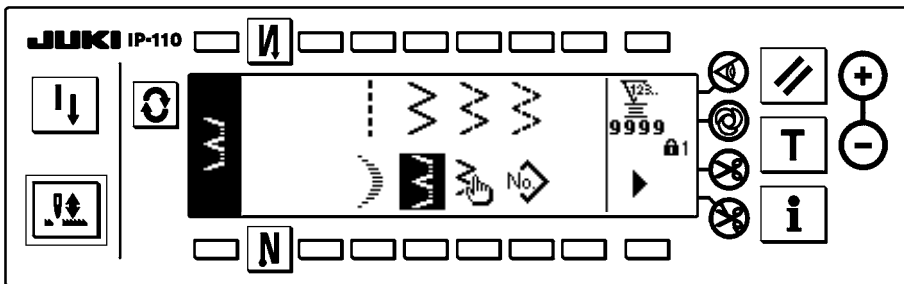

- 3) The selected shape reverses and is indicated on the left end of the screen.

- 4) Press  to display the sewing shape setting screen.

■ Sewing shape setting screen

● First screen

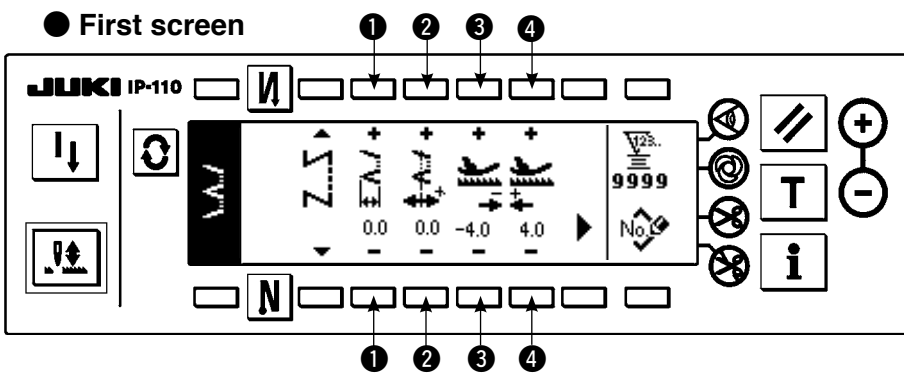

● Second screen

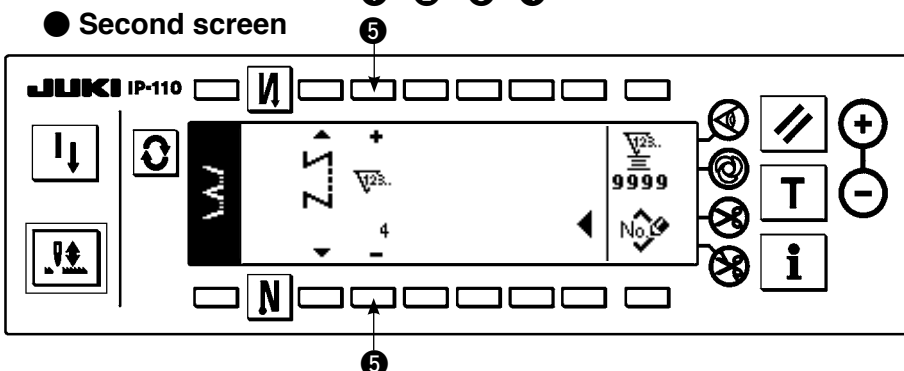

- **Setting of the zigzag width**
Change the zigzag width with +/- of switch **1**.
- **Setting of the position of stitch base line**
Change the position of stitch base line with +/- of switch **2**.
- **Setting of the reverse feed amount**
Change the reverse feed amount with +/- of switch **3**.
- **Setting of the normal feed amount**
Change of the normal feed amount with +/- of switch **4**.
- **Change of the number of stitches**
Change the number of stitches with +/- of switch **5**.

(4) Custom pattern stitching

■ Sewing shape list first screen

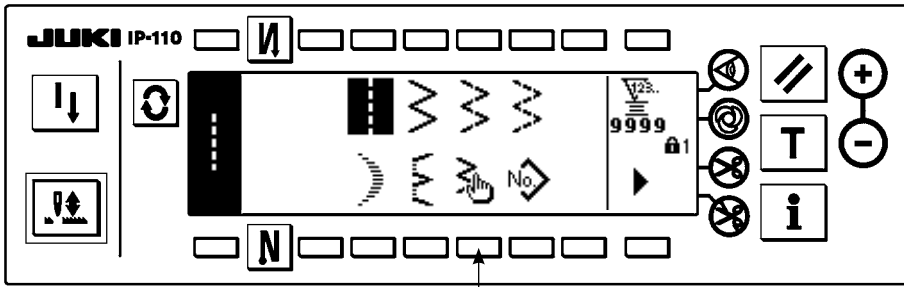

- 1) Select custom pattern ① in the sewing shape list first screen.



■ Custom pattern selection pop-up screen

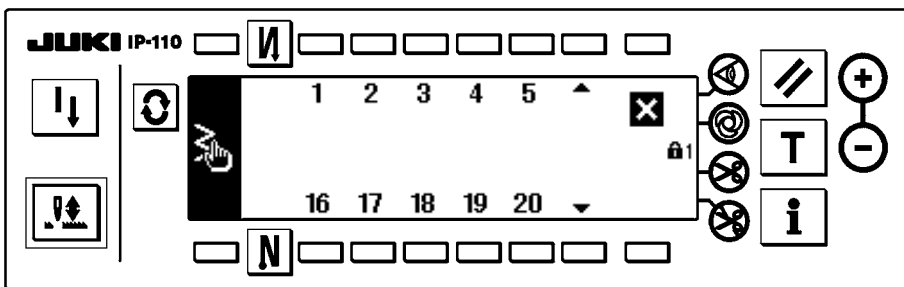

- 2) Press the custom pattern No. to be selected.



■ Sewing shape list first screen

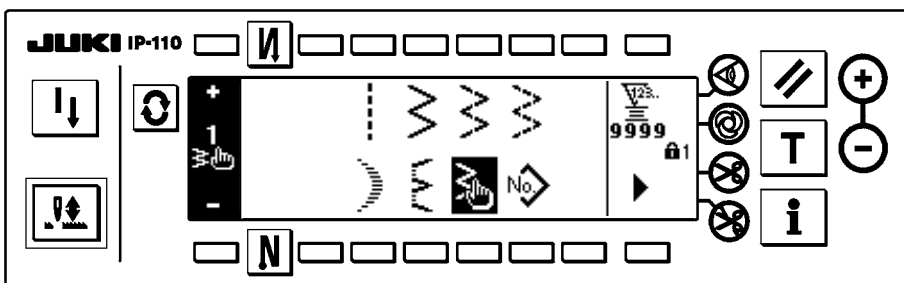

- 3) The selected shape reverses and is indicated on the left end of the screen.
- 4) Press  to display the sewing shape setting screen.

■ Sewing shape setting screen

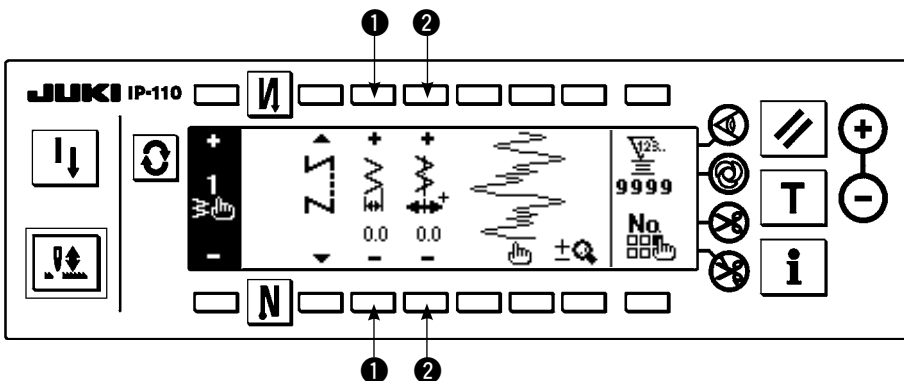

- **Setting of the zigzag width**
Change the zigzag width with +/- of switch ①.
- **Setting of the position of stitch base line**
Change the position of stitch base line with +/- of switch ②.

(5) T stitch, left

■ Sewing shape list second screen

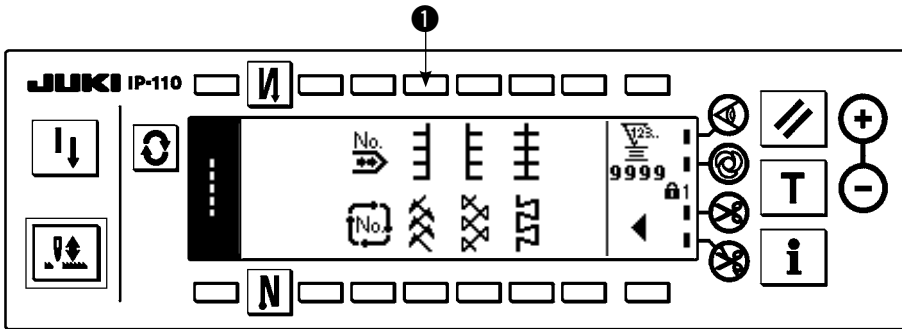

- 1) Select T stitch, left sewing ① in the sewing shape list second screen.
- 2) The selected shape reverses and is indicated on the left end of the screen.
- 3) Press  to display the sewing shape setting screen.

■ Sewing shape setting screen

● First screen

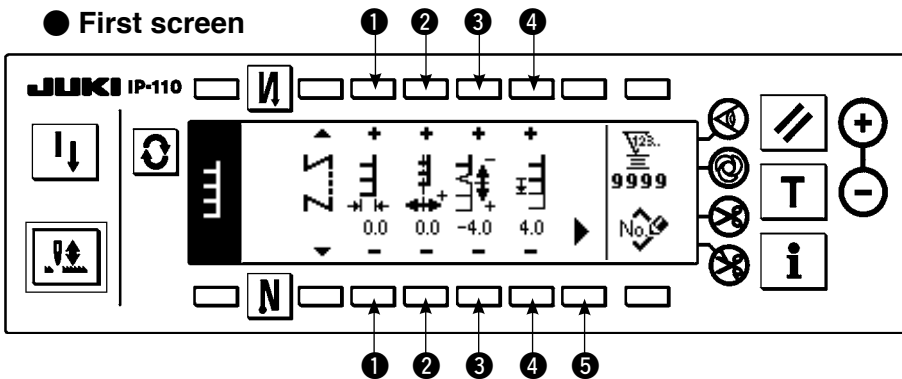

● Second screen

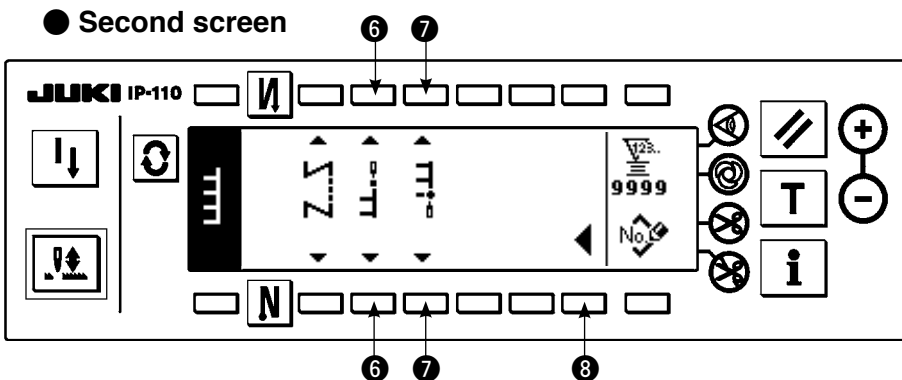

The feed amount cannot be set to 0 and the T stitch pattern may be deformed due to materials, height of fed dog or gauges. (2nd stitch does not correspond with 4th stitch.)
 In this case, perform compensation with switch ③ "Setting of the compensation amount of seam section at feed amount "0"" to make the stitches correspond with each other.

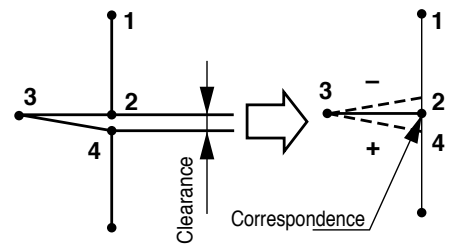

● Setting of the zigzag width

Change the zigzag width with +/- of switch ①.

● Setting of the position of stitch base line

Change the position of stitch base line with +/- of switch ②.

● **Setting of the compensation amount of seam section at feed amount "0"**

Change the normal feed amount with +/- of switch ③.

● **Setting of the normal feed amount**

Change the feed amount with +/- of switch ④.

● **Display of the second screen**

Display the sewing shape setting second screen with switch ⑤.

● **Setting of the position of sewing start**

Set the position of sewing start with ▲ / ▼ of switch ⑥.



Position of sewing start, left

Position of sewing start, right 1

Position of sewing start, right 2

Free position of sewing start

● **Setting of the stop position**

Set the stop position with ▲ / ▼ of switch ⑦.



Position of sewing end, left

Position of sewing end, right 1

Position of sewing end, right 2

Free position of sewing end

● **Display of the first screen**

Display the sewing shape setting first screen with switch ⑧.

(6) T stitch, right

■ **Sewing shape list second screen**

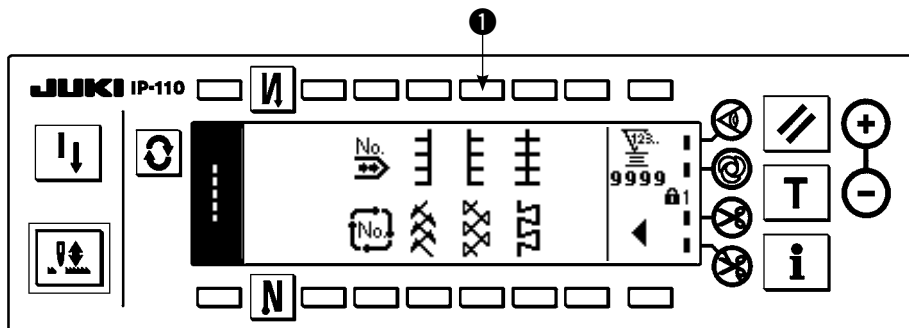

- 1) Select T stitch, right sewing ① in the sewing shape list second screen.
- 2) The selected shape reverses and is indicated on the left end of the screen.
- 3) Press  to display the sewing shape setting screen.

■ **Sewing shape setting screen**

● **First screen**

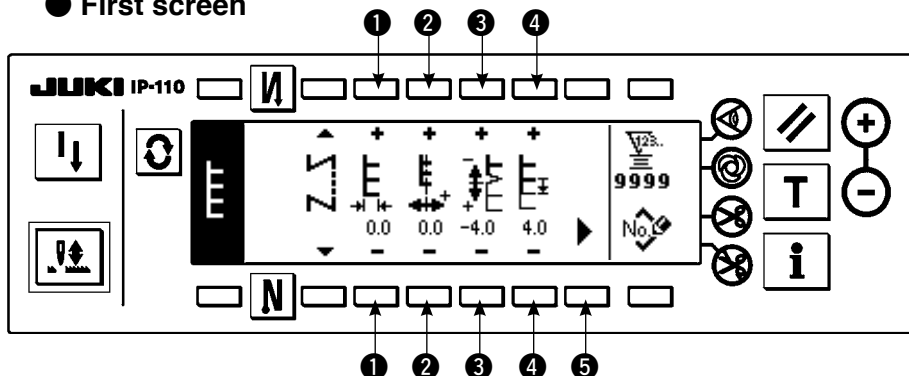

● **Second screen**

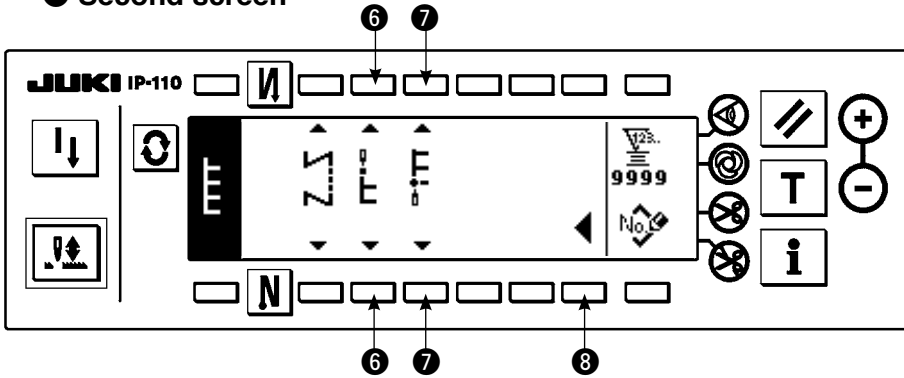

Caution

The feed amount cannot be set to 0 and the T stitch pattern may be deformed due to materials, height of fed dog or gauges. (2nd stitch does not correspond with 4th stitch.) In this case, perform compensation with switch ③ “Setting of the compensation amount of seam section at feed amount “0”” to make the stitches correspond with each other.

● **Setting of the zigzag width**

Change the zigzag width with +/- of switch ①.

● **Setting of the position of stitch base line**

Change the position of stitch base line with +/- of switch ②.

● **Setting of the compensation amount of seam section at feed amount "0"**

Change the normal feed amount with +/- of switch ③.

● **Setting of the normal feed amount**

Change the feed amount with +/- of switch ④.

● **Display of the second screen**

Display the sewing shape setting second screen with switch ⑤.

● **Setting of the position of sewing start**

Set the position of sewing start with ▲ / ▼ of switch ⑥.



Position of sewing start, left



Position of sewing start, left 1



Position of sewing start, left 2



Free position of sewing start

● **Setting of the stop position**

Set the stop position with ▲ / ▼ of switch ⑦.



Position of sewing end, left



Position of sewing end, left 1



Position of sewing end, left 2



Free position of sewing end

● **Display of the first screen**

Display the sewing shape setting first screen with switch ⑧.

(7) Pattern 1

■ Sewing shape list second screen

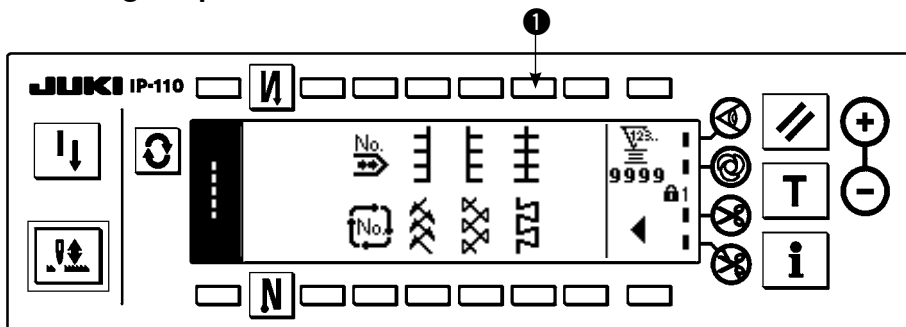

- 1) Select pattern 1 sewing ① in the sewing shape list second screen.
- 2) The selected shape reverses and is indicated on the left end of the screen.
- 3) Press  to display the sewing shape setting screen.

■ Sewing shape setting screen

● First screen

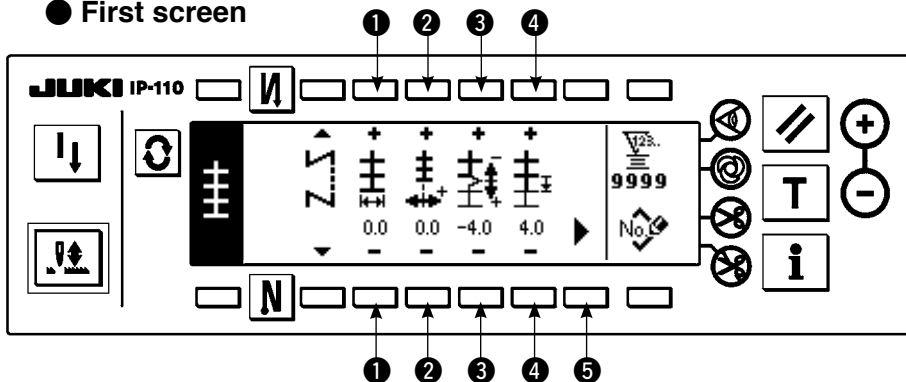

● Second screen

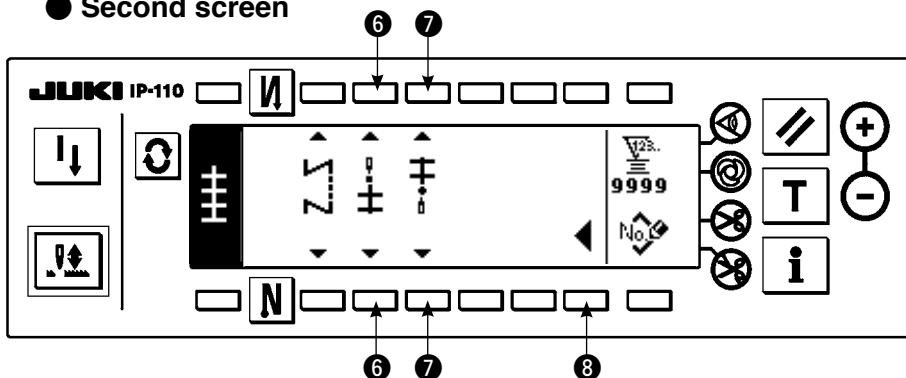

● Setting of the zigzag width

Change the zigzag width with +/- of switch ①.

● Setting of the position of stitch base line

Change the position of stitch base line with +/- of switch ②.

● Setting of the normal feed amount

Change the feed amount with +/- of switch ③.

● Setting of the compensation amount of seam section at feed amount "0"

Change the normal feed amount with +/- of switch ④.

● **Display of the second screen**

Display the sewing shape setting second screen with switch ⑤.

● **Setting of the position of sewing start**

Set the position of sewing start with ▲ / ▼ of switch ⑥.



Position of sewing start, center 1



Position of sewing start, center 2



Position of sewing start, left



Position of sewing start, center 3



Position of sewing start, right



Free position of sewing start



Free position of sewing start starts from the next needle entry after thread trimming.

● **Setting of the stop position**

Set the stop position with ▲ / ▼ of switch ⑦.



Position of sewing end, center 1



Position of sewing end, center 2



Position of sewing end, left



Position of sewing end, center 3



Position of sewing end, right



Free position of sewing end

● **Display of the first screen**

Display the sewing shape setting first screen with switch ⑧.

(8) Pattern 2 (fagoting)

■ **Sewing shape list second screen**

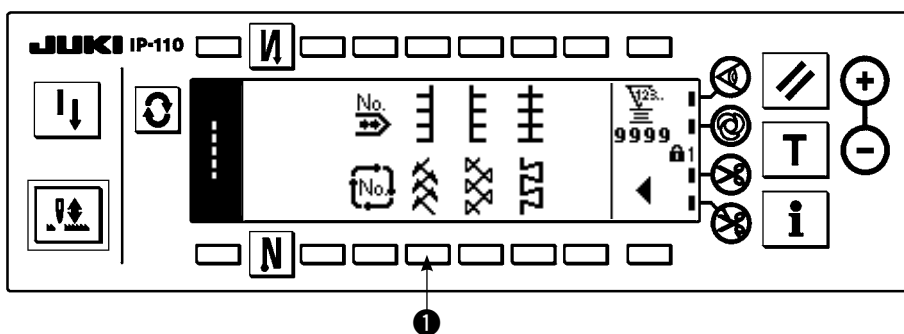

- 1) Select pattern 2 sewing ❶ in the sewing shape list second screen.
- 2) The selected shape reverses and is indicated on the left end of the screen.
- 3) Press to display the sewing shape setting screen.



When performing fagoting sewing, exclusive gauge is necessary. For the details, see p.125.

■ Sewing shape setting screen

● First screen

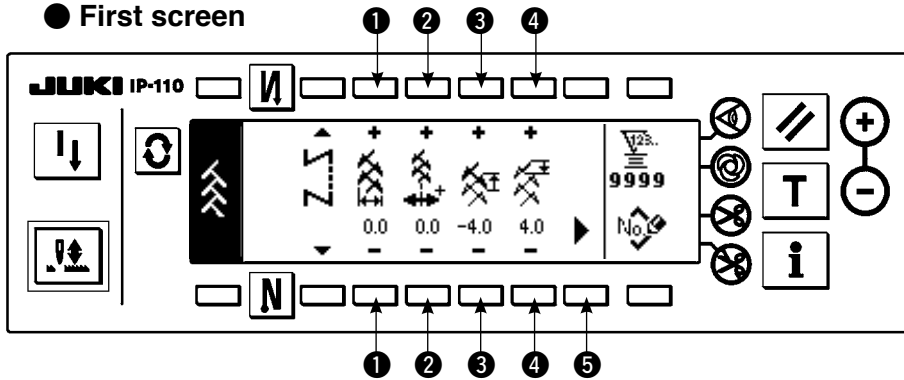

● Second screen

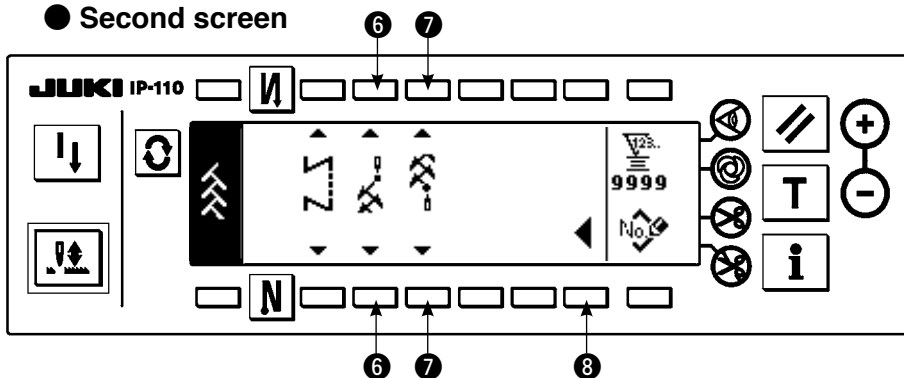

● Setting of the zigzag width

Change the zigzag width with +/- of switch ①.

● Setting of the position of stitch base line

Change the position of stitch base line with +/- of switch ②.

● Setting of the reverse feed amount

Change the reverse feed amount with +/- of switch ③.



Feed amount becomes "0" when the hand switch is pressed.

● Setting of the normal feed amount

Change the feed amount with +/- of switch ④.

● Display of the second screen

Display the sewing shape setting second screen with switch ⑤.

● Setting of the position of sewing start

Set the position of sewing start with ▲ / ▼ of switch ⑥.



Position of sewing start, right 1



Position of sewing start, center 1



Position of sewing start, left 1



Position of sewing start, left 2



Position of sewing start, center 2



Position of sewing start, right 2



Free position of sewing start



Free position of sewing start starts from the next needle entry after thread trimming.

● **Setting of the stop position**

Set the stop position with ▲ / ▼ of switch ⑦.



Position of sewing end, right 1



Position of sewing end, center 1



Position of sewing end, left 1



Position of sewing end, left 2



Position of sewing end, center 2



Position of sewing end, right 2



Free position of sewing end

● **Display of the first screen**

Display the sewing shape setting first screen with switch ⑧.

(9) Pattern 3

■ **Sewing shape list second screen**

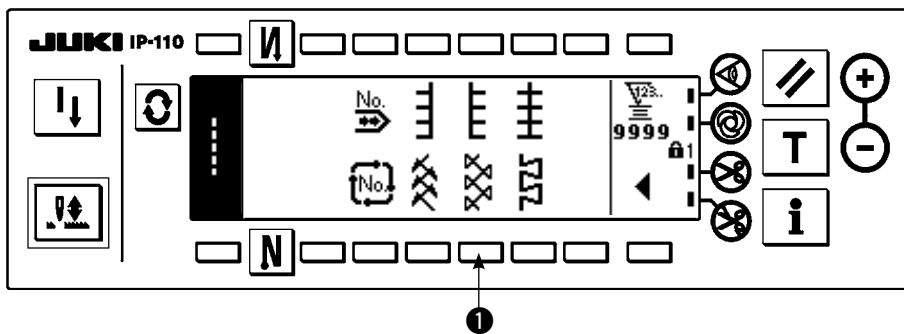

- 1) Select pattern 2 sewing ① in the sewing shape list second screen.
- 2) The selected shape reverses and is indicated on the left end of the screen.
- 3) Press  to display the sewing shape setting screen.

■ **Sewing shape setting screen**

● **First screen**

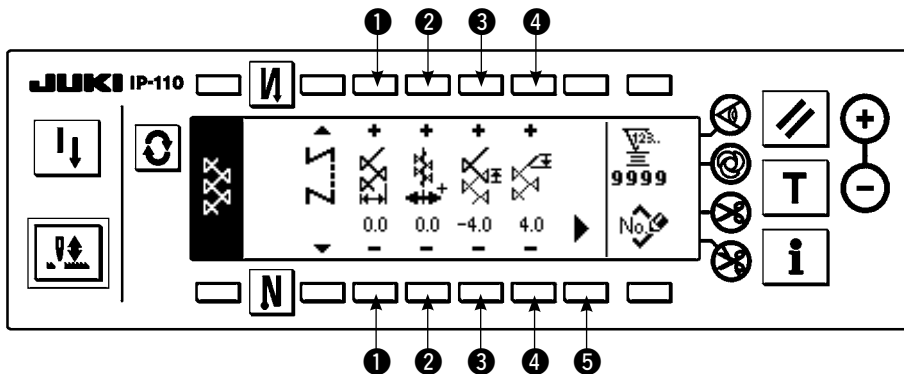

● **Second screen**

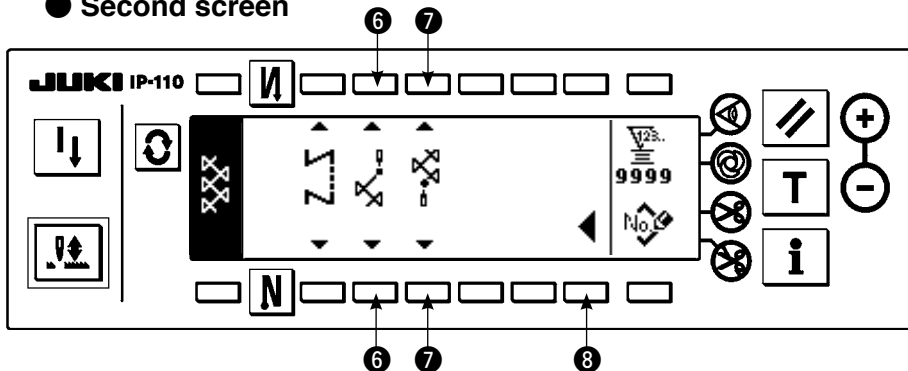

● **Setting of the zigzag width**

Change the zigzag width with +/- of switch ①.

● **Setting of the position of stitch base line**

Change the position of stitch base line with +/- of switch ②.

● **Setting of the reverse feed amount**

Change the reverse feed amount with +/- of switch ③.

 **Feed amount becomes "0" when the hand switch is pressed.**

● **Setting of the normal feed amount**

Change the feed amount with +/- of switch ④.

● **Display of the second screen**

Display the sewing shape setting second screen with switch ⑤.

● **Setting of the position of sewing start**

Set the position of sewing start with ▲ / ▼ of switch ⑥.



Position of sewing start, right 1



Position of sewing start, center 1



Position of sewing start, left 1



Position of sewing start, left 2



Position of sewing start, center 2



Position of sewing start, right 2



Free position of sewing start

 **Free position of sewing start starts from the next needle entry after thread trimming.**

● **Setting of the stop position**

Set the stop position with ▲ / ▼ of switch ⑦.



Position of sewing end, right 1



Position of sewing end, center 1



Position of sewing end, left 1



Position of sewing end, left 2



Position of sewing end, center 2



Position of sewing end, right 2



Free position of sewing end

● **Display of the first screen**

Display the sewing shape setting first screen with switch ⑧.

(10) Pattern 4

■ Sewing shape list second screen

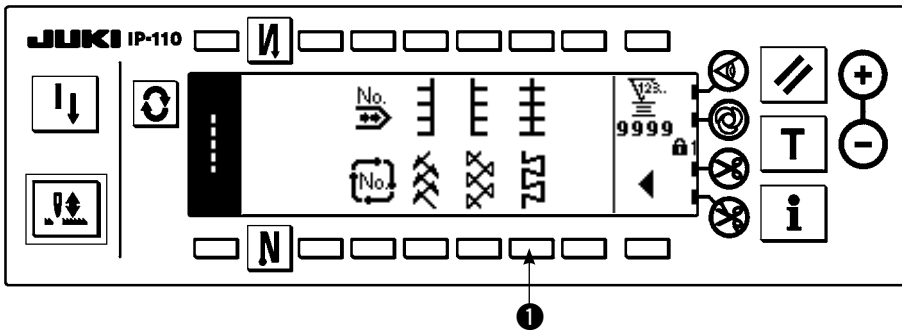

- 1) Select pattern 2 sewing ① in the sewing shape list second screen.
- 2) The selected shape reverses and is indicated on the left end of the screen.
- 3) Press  to display the sewing shape setting screen.

■ Sewing shape setting screen

● First screen

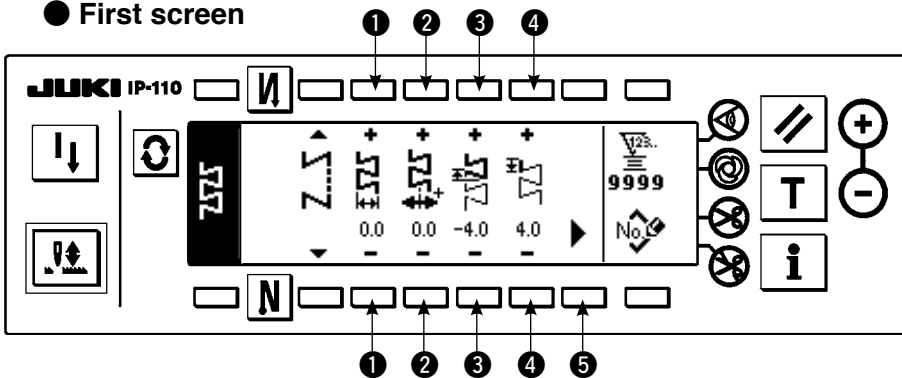

● Second screen

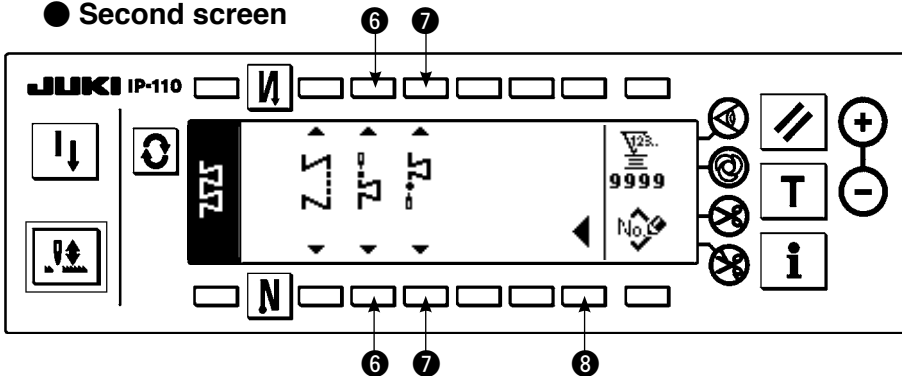

● Setting of the zigzag width

Change the zigzag width with +/- of switch ①.

● Setting of the position of stitch base line

Change the position of stitch base line with +/- of switch ②.

● Setting of the reverse feed amount

Change the reverse feed amount with +/- of switch ③.



Feed amount becomes "0" when the hand switch is pressed.

- **Setting of the normal feed amount**

Change the feed amount with +/- of switch ④.

- **Display of the second screen**

Display the sewing shape setting second screen with switch ⑤.

- **Setting of the position of sewing start**

Set the position of sewing start with ▲ / ▼ of switch ⑥.



Position of sewing start, left 1



Position of sewing start, left 2



Position of sewing start, right 1



Position of sewing start, right 2



Position of sewing start, right 3



Position of sewing start, left 3



Free position of sewing start



Free position of sewing start starts from the next needle entry after thread trimming.

- **Setting of the stop position**

Set the stop position with ▲ / ▼ of switch ⑦.



Position of sewing end, left 1



Position of sewing end, left 2



Position of sewing end, right 1



Position of sewing end, right 2



Position of sewing end, right 3



Position of sewing end, left 3



Free position of sewing end

- **Display of the first screen**

Display the sewing shape setting first screen with switch ⑧.

6-7. Setting of the number of rotations

The number of rotations can be set at each pattern (cycle stitching is not possible to set the number of rotations). Setting of the number of rotations can be performed in the reverse feed stitching setting second screen (when the pattern is the overlapped stitching, perform it in the overlapped stitching setting second screen).

Reverse feed stitching setting second screen

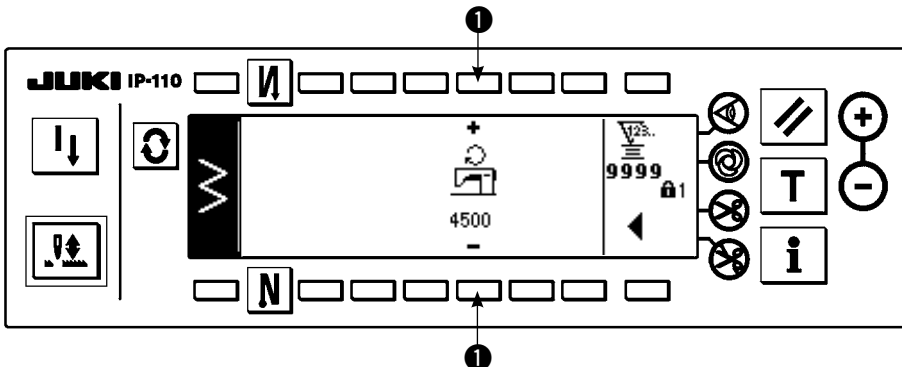

① : Number of rotations is set. 200 to 5,000 can be set in increments of 200.



Number of rotations is limited by zigzag width, feed amount, function setting No. 96 Max. number of rotations setting, etc. In this case, the minimum setting is prior.



There are cases where the shapes are not stabilized in case of some custom patterns which frequently repeat normal and reverse feed stitching. In this case, set the sewing speed at approximately 2,000 sti/min.

6-8. Reverse feed stitching

V ①	OFF	ON	OFF	ON
Sewing pattern				
N ②	OFF	OFF	ON	ON

Reverse feed stitching can be set with each zigzag pattern.

Effective/ineffective of reverse feed stitching can be set by pressing reverse feed stitch at sewing start switch ① and reverse feed stitch at sewing end switch ②. In case the reverse feed stitching is effective, the respective shapes of the reverse feed stitching are displayed. In case of ineffective, the shape is not displayed.

Reverse feed stitching setting screen

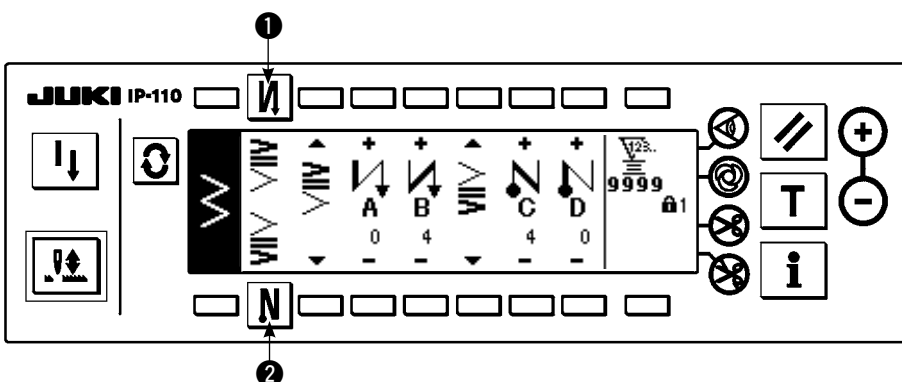

For the reverse feed stitching, there are standard condensation, 2-point condensation and condensation custom.

(1) Standard condensation

Standard condensation performs reverse feed stitching at the same needle entry as that of the selected zigzag pattern.

Example) Reverse feed stitching at sewing end

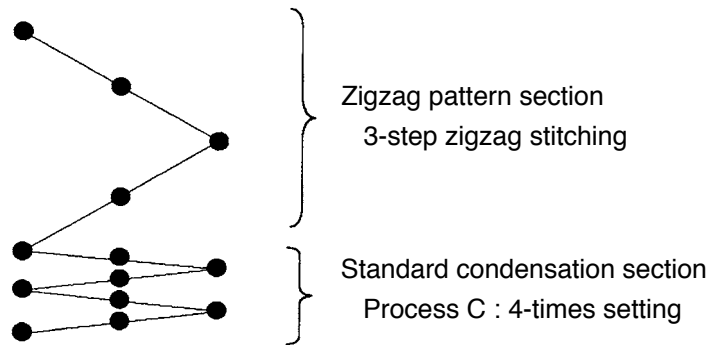

Example) In case of free stitching of the standard zigzag stitch

1) Press  to display reverse feed stitching setting screen.

2) Set the shape of condensation and number of stitches.

- ① : Select the shape of condensation at the sewing start.
- ② : Set the number of stitches of process A with “+” and “-”.
- ③ : Set the number of stitches of process B with “+” and “-”.
- ④ : Select the shape of condensation at the sewing end.
- ⑤ : Set the number of stitches of process C with “+” and “-”.
- ⑥ : Set the number of stitches of process D with “+” and “-”.
- ⑦ : Reverse feed stitching setting second screen is displayed.

Display section of ① and ④ : Standard condensation, 2-point condensation and condensation custom (20 patterns) are changed over and displayed.

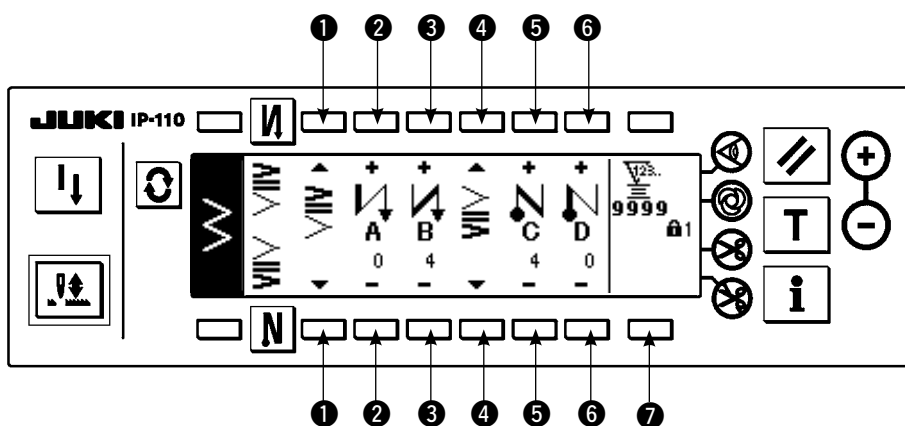

■ Reverse feed stitching setting (standard condensation) screen



* For the reverse feed stitching setting, there are two kinds of methods below according to the zigzag patterns.

1) In case of straight stitch, scallop stitch, blind stitch, custom and continuous stitch, set the reverse feed stitching with the number of stitches.

- Reverse feed stitching at sewing start → A (feed in normal direction) : 0 to 19 stitches can be set. ②
 B (feed in reverse direction) : 0 to 19 stitches can be set. ③
- Reverse feed stitching at sewing end → C (feed in reverse direction) : 0 to 19 stitches can be set. ⑤
 D (feed in normal direction) : 0 to 19 stitches can be set. ⑥

* The pictures in case of straight stitching are ① sewing start  and ④ sewing end .

2) In case of 2-step zigzag, 3-step zigzag and 4-step zigzag, set the reverse feed stitching with the number of times of zigzag pattern. Zigzag pattern means the space between the returning points of zigzag.

- Reverse feed stitching at sewing start → A (feed in normal direction) : 0 to 19 times can be set. ②
 B (feed in reverse direction) : 0 to 19 times can be set. ③
- Reverse feed stitching at sewing end → C (feed in reverse direction) : 0 to 19 times can be set. ⑤
 D (feed in normal direction) : 0 to 19 times can be set. ⑥

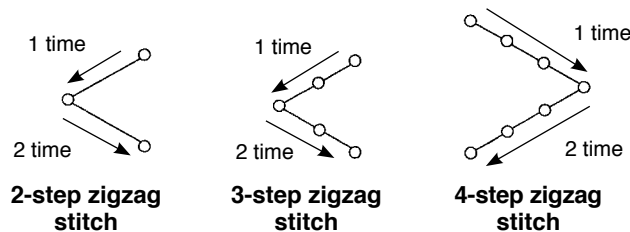

* Setting of the reverse feed amount of custom pattern stitching or continuous stitching

⑦ : Transits to the second screen.

■ Reverse feed stitching setting second screen

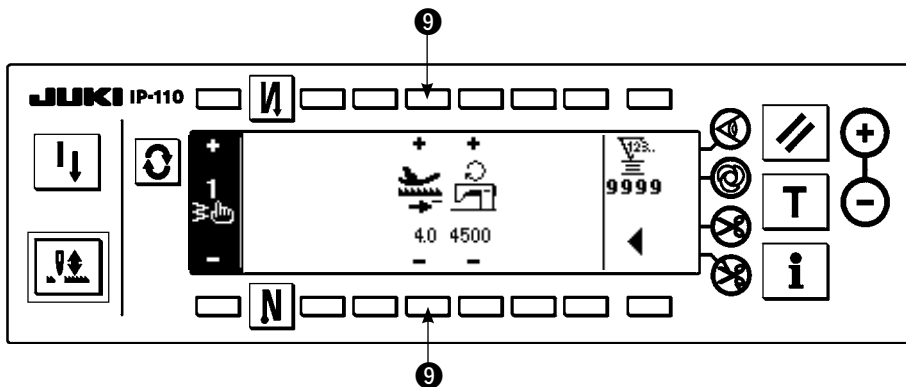
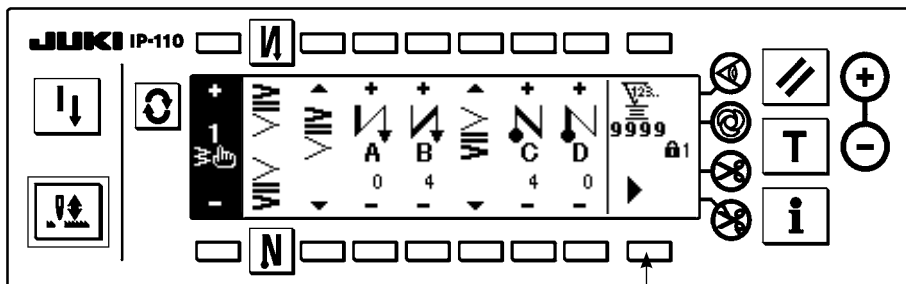

⑨ : Feed amount at the time of automatic reverse feed stitching or pressing the hand switch is set. The feed amounts from the feed amount set in the pattern setting screen to the reverse feed amount set here continuously change by pressing down the reverse feed control lever during sewing.

(2) 2-point condensation

2-point condensation performs reverse feed stitching of two points between the existing needle entry of the selected zigzag pattern and the next needle entry.

The width between two points can be adjusted in the direction of “-”.

Example) Reverse feed stitching at sewing end

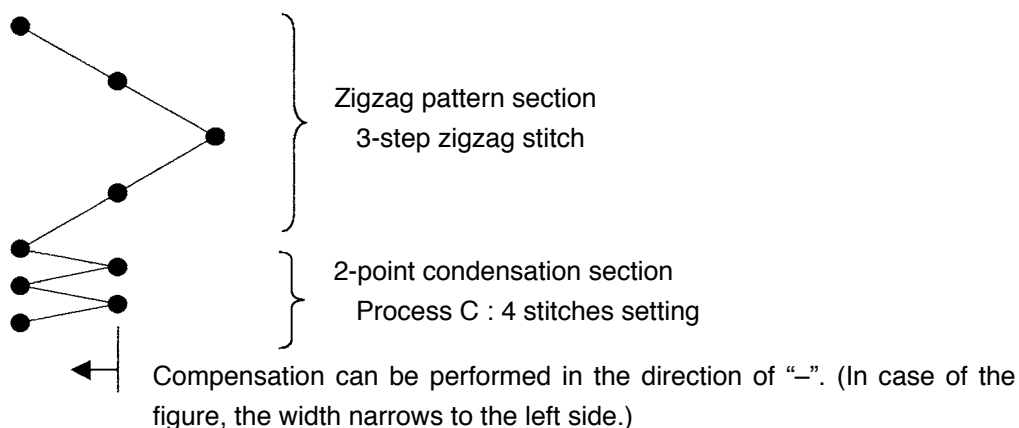

Example) In case of free stitching of the 2-step zigzag stitch

- 1) Press to display reverse feed stitching setting screen.
- 2) Set the shape of condensation and number of stitches with the first screen.
 - ① : Select the shape of condensation at the sewing start.
 - ② : Set the number of stitches of process A with “+” and “-”. 0 to 19 stitches can be set.
 - ③ : Set the number of stitches of process B with “+” and “-”. 0 to 19 stitches can be set.
 - ④ : Select the shape of condensation at the sewing end.
 - ⑤ : Set the number of stitches of process C with “+” and “-”. 0 to 19 stitches can be set.
 - ⑥ : Set the number of stitches of process D with “+” and “-”. 0 to 19 stitches can be set.

Display section of ① and ④ : Standard condensation, 2-point condensation and condensation custom (20 patterns) are changed over and displayed.
- 3) Set 2-point condensation width adjustment with the second screen. (Width can be narrowed up to max. -5 mm.)
 - ⑦ : Set 2-point condensation width adjustment at the sewing start.
 - ⑧ : Set 2-point condensation width adjustment at the sewing end.

* 2-point condensation width adjustment can narrow the width from the first needle entry position to the next needle entry position when performing the reverse feed stitching. (When set value is “0”, there is no compensation.)

* When the width adjustment is performed, the width between 2 points can be narrowed and the fray of thread is lessened.

■ The first screen of reverse feed stitching setting (2-point condensation)

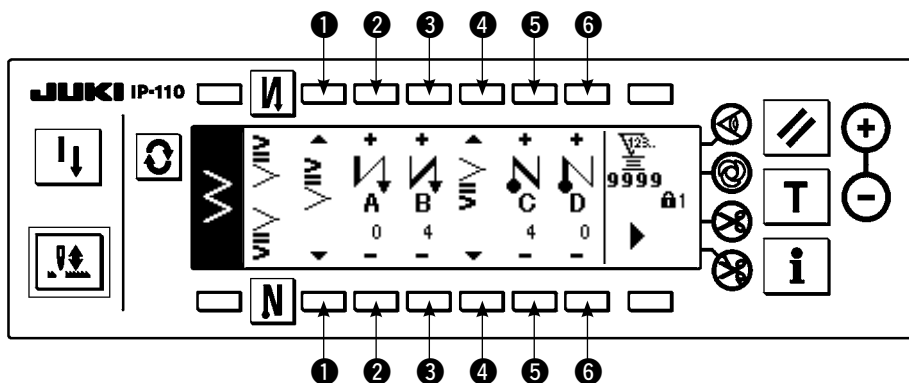

Press to display the second screen.

■ The second screen of reverse feed stitching setting (2-point condensation)

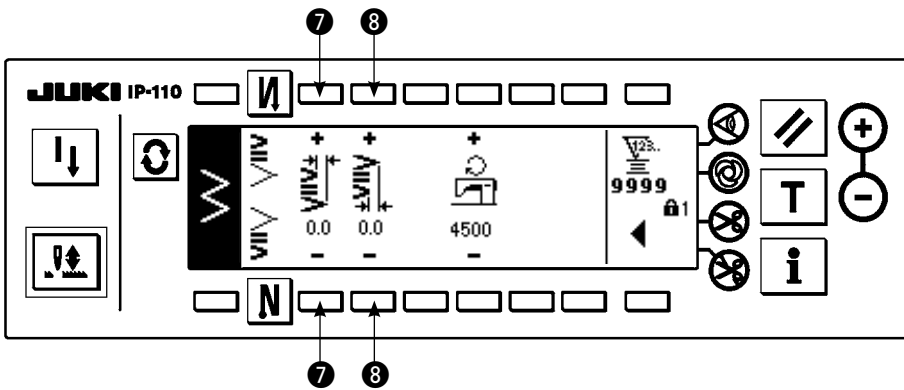

Press ◀ to display the first screen.

(3) Condensation custom

Condensation custom performs reverse feed stitching with the optional needle entry which has been inputted.

1) Select the shape of condensation with the first screen.

- ① : Select the shape of condensation at the sewing start.
- ③ : Select the shape of condensation at the sewing end.
- ②, ④ : Needle entry position is displayed.
- ⑤ : Total display and partial display of the condensation custom pattern are changed over.

2) Set the width of condensation custom pattern with the second screen.

- ⑥ : Set the width of condensation custom pattern at the sewing start.
- ⑦ : Set the width of condensation custom pattern at the sewing end.

* Separately set inputted zigzag width of condensation custom from that of normal sewing section. Set the width within the range of maximum zigzag width limitation.

* By setting the width, the needle entry differs from actually inputted needle entry position.

■ The first screen of reverse feed stitching setting (condensation custom)

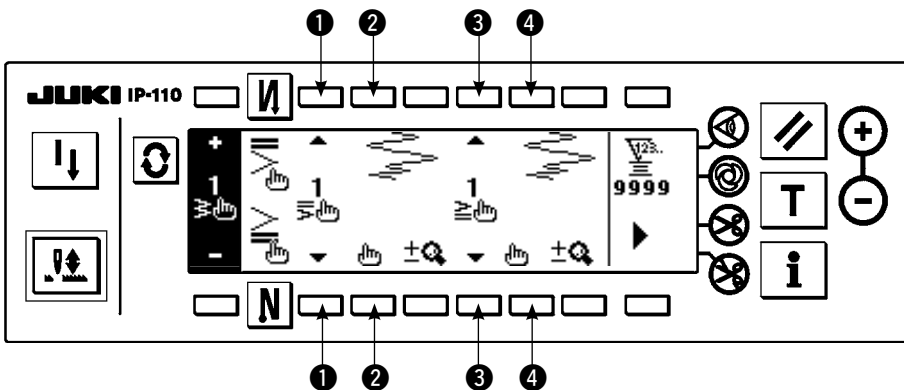

Press ▶ to move the screen to the edit screen.

* For the editing procedure, refer to the item of 6-10. Custom pattern.

Press ▶ to display the second screen.

■ The second screen of reverse feed stitching setting (condensation custom)

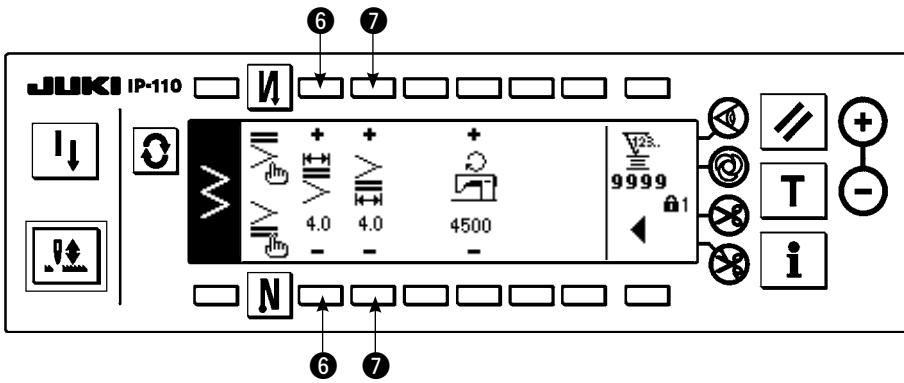

Press ◀ to display the first screen.

(4) Comparison table of the reverse stitch of each shape

	Standard condensation		2-point condensation		Condensation custom	
	Sewing start	Sewing end	Sewing start	Sewing end	Sewing start	Sewing end
Straight stitch						
2-step zigzag stitch						
3-step zigzag stitch						
4-step zigzag stitch						
Scallop						
Blind stitch						
T stitch, left						
T stitch, right						
Pattern 1						
Pattern 2 (fagoting)						
Pattern 3						
Pattern 4						
Custom						
Continuous stitch						

6-9. Selection of the kind of stitching





Standard delivery level of the key lock is “1”. When the level of the key lock is the case other than “0”, be sure to change the level to “0” to perform the operation below.

Example) 2-step zigzag

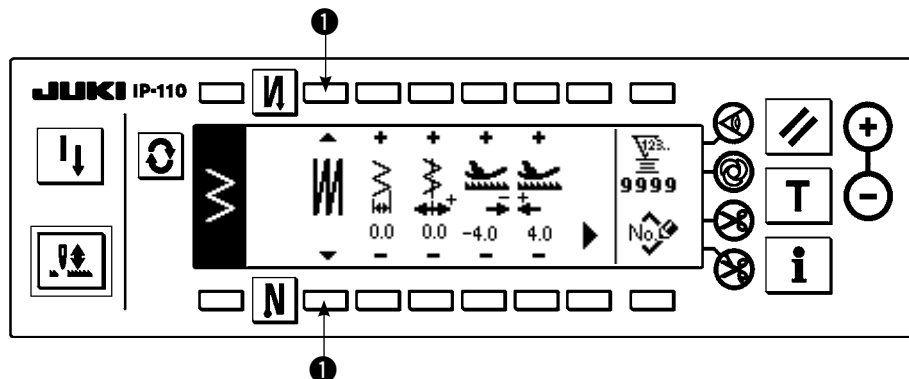
■ Sewing shape setting screen





Select the kind of stitching from among free stitching , overlapped stitching  and programmed stitching . Press switch ① of sewing shape setting screen to select the kind.

(1) Overlapped stitching

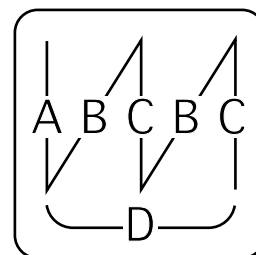
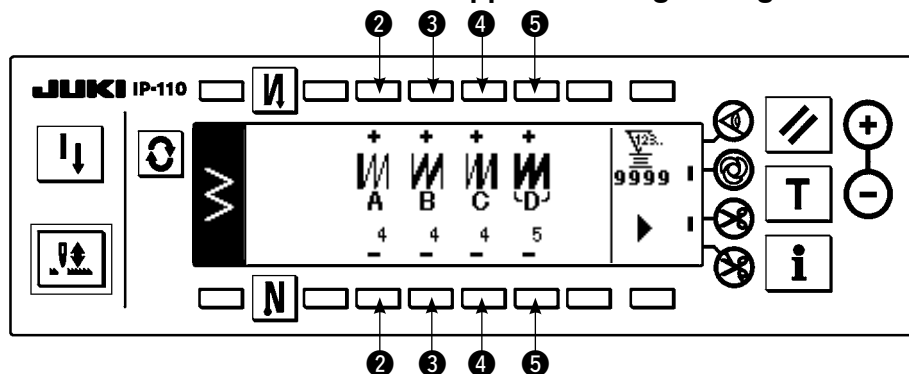
■ The first screen of the overlapped stitching setting screen



- 1) Select  showing overlapped stitching with ① of sewing shape setting screen.
- 2) Press  in the sewing shape setting screen to display the first screen of the overlapped stitching setting.
- 3) Input the number of stitches of the respective processes and the number of processes in the first screen of the overlapped stitching setting.
 - ② : Set the number of stitches of process A with “+” and “-”. 0 to 19 stitches for the number of stitches of section A can be set.
 - ③ : Set the number of stitches of process B with “+” and “-”. 0 to 19 stitches for the number of stitches of section B can be set.
 - ④ : Set the number of stitches of process C with “+” and “-”. 0 to 19 stitches for the number of stitches of section C can be set.
 - ⑤ : Set the number of processes with “+” and “-”. 0 to 9 times for the number of processes can be set.
 - ⑥ : The second screen of the overlapped stitching setting is displayed.
- 4) Set the enlargement/reduction of the needle entry and the max. number of revolutions in the second screen of the overlapped stitching setting.
- 5) By performing depressing the front part of the pedal, the sewing machine repeats the specified number of times of normal and reverse feed stitching, performs automatic thread trimming and stops.
 - * Turn ON the thread trimming prohibition switch ON when you desire to stop the sewing machine with needle UP position without performing thread trimming after all processes have been completed.
 - * Thread trimming is performed at any occasion in case of one-shot stitching and the last of process. The one-shot stitching cannot be turned OFF.

■ The second screen of the overlapped stitching setting screen

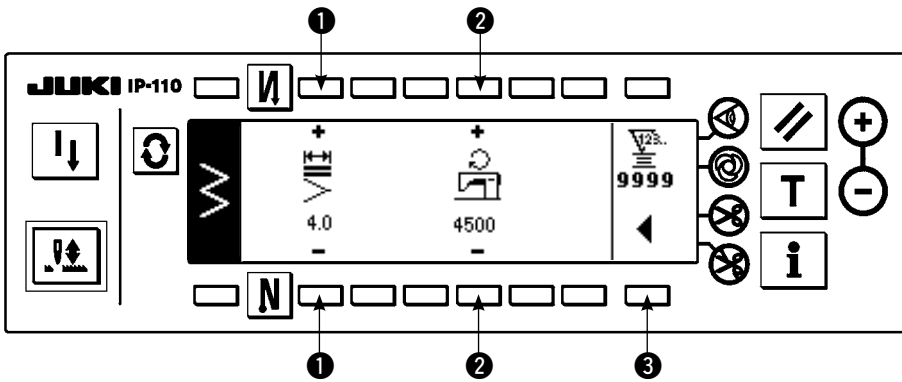

- ❶ : Enlargement/reduction of the needle entry can be performed.
- ❷ : Max. number of revolutions can be set.
- ❸ : The first screen of the overlapped stitching is displayed.

(2) Programmed stitching

■ Programmed stitching

Programmed stitching can program the constant-dimension stitching process up to 20 steps and set the number of stitches to each step up to 500 stitches.

* For the programmed stitching, the pattern registration cannot be performed.

Example) 2-step zigzag

■ Sewing shape setting screen

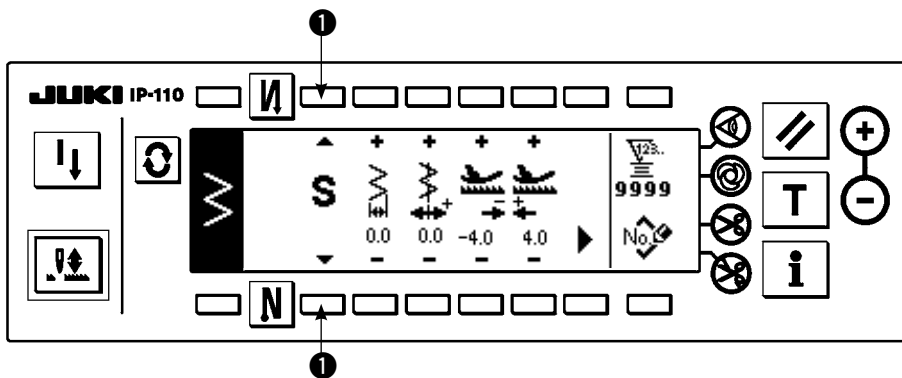

- 1) Select **S** showing programmed stitching with ❶ of sewing shape setting screen.

■ Programmed stitching selection screen

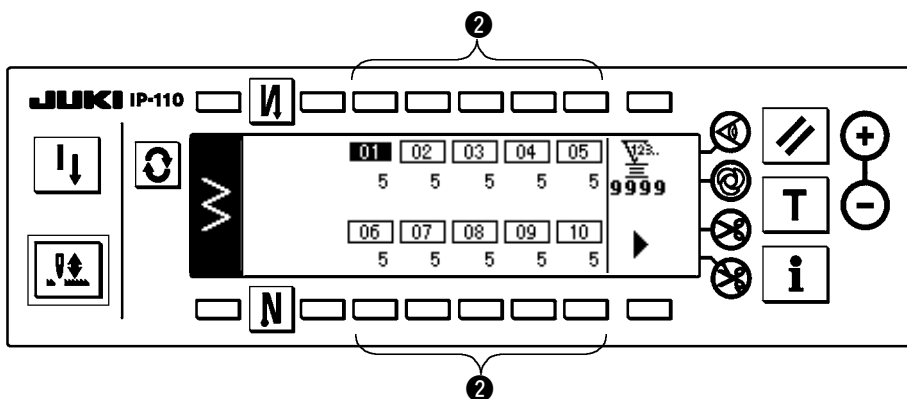

Press , in case of more than 10 steps, and programmed stitching selection screen of “11” to “20” is displayed.

Press and the screen returns to programmed stitching selection screen of “01” to “10”.

2) Press to display the programmed stitching setting screen.

3) Number of stitches of each step is displayed in the programmed stitching setting screen.

Press switch **2** corresponding to each step and the screen moves to the programmed stitching edit screen.



When automatic thread trimming is selected, “0” is not displayed in the last step.

When increasing the number of steps, proceed to the next step after releasing automatic thread trimming.

■ Programmed stitching edit screen

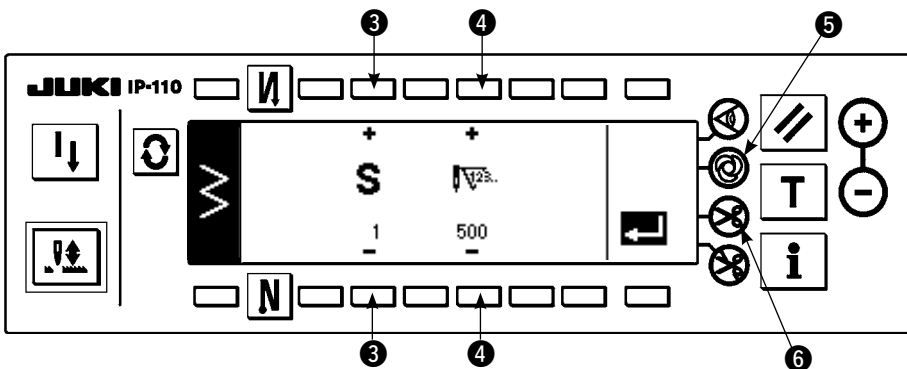

4) Set the number of stitches of each step in the programmed stitching edit screen.

3 : Set the step with “+” and “-”. As many as 20 steps can be set.

4 : Set the number of stitches with “+” and “-”. As many as 500 stitches can be set.

5) When setting of all steps has been completed, select automatic thread trimming **6** at the last step, or set “0” stitch to the next step.

When the last step is “20”, it is not necessary to set “0” stitch at the next step.

6) When setting is completed, press key to determine the contents of setting.



When the power source is turned OFF without pressing key, the inputted data returns to the former one. When you desire to determine the data, be sure to press key.

■ One-shot automatic stitching

One-shot automatic stitching can be set by each step.

1) In the programmed stitching edit screen, press one-shot automatic stitching switch **5** to select the one-shot automatic stitching. (When it is in the selected state, a mark is displayed on the side of switch **5**.)

2) In the step where the one-shot automatic stitching has been selected, the sewing machine will automatically continue sewing, once the sewing machine starts running, until the number of stitches of the step is reached.

■ Teaching

Teaching can input the number of stitches of inputting step with the number of stitches which has been actually sewn.

- 1) Press **T** switch in the programmed stitching edit screen and the teaching mode is selected.
- 2) Depress the front part of the pedal to sew until the last stitch of the step is reached.
 - * At this time, input of number of stitches cannot be performed by turning handwheel by hand or using needle up/down compensating switch.
- 3) Stop the sewing machine with the pedal in the neutral position and the number of stitches which has been sewn is displayed on ②.
 - ① : Set the step with "+".
 - ② : Number of stitches which has been sewn can be corrected by hand with "+" and "-".
- 4) Make the step of ① proceed to the subsequent step or make the sewing machine perform thread trimming. Then the input of the number of stitches for the step is completed.

■ Teaching screen

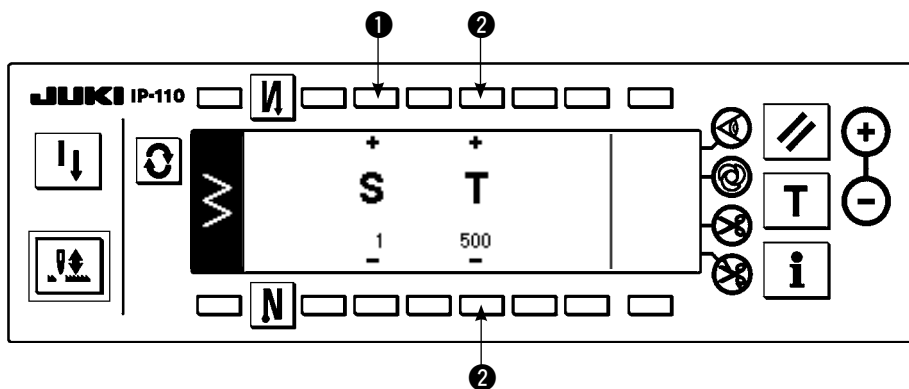

6-10. Custom pattern



Standard delivery level of the key lock is "1". When the level of the key lock is the case other than "0", be sure to change the level to "0" to perform the operation below.



- There are cases where the sewing shapes are not stabilized in case of the patterns which frequently repeat normal and reverse feed stitching. Use the machine at the sewing speed of approximately 2,000 sti/min.
- There are cases where the value inputted to the operation panel and the actual sewing pitch are different from each other due to materials and gauges. Perform compensation of the pitch in accordance with the sewing products.

Free needle entry position can be specified and optional zigzag pattern can be created.

As many as 20 patterns can be created and as many as 500 stitches of each pattern can be inputted.

(1) Custom pattern setting

■ Sewing shape list screen

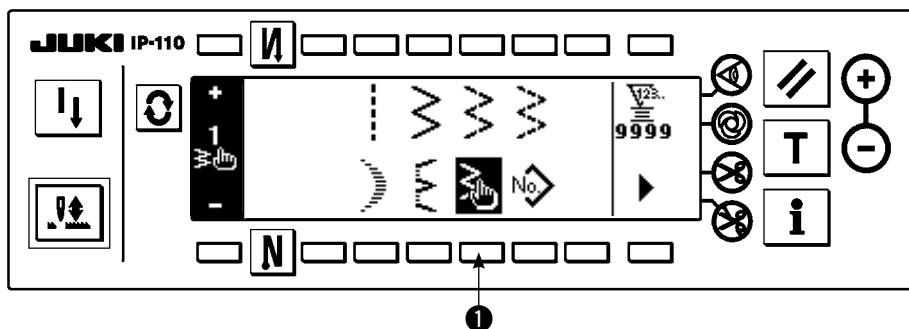

- 1) Press switch ① of  in the sewing shape list screen.

■ Custom pattern selection pop-up screen

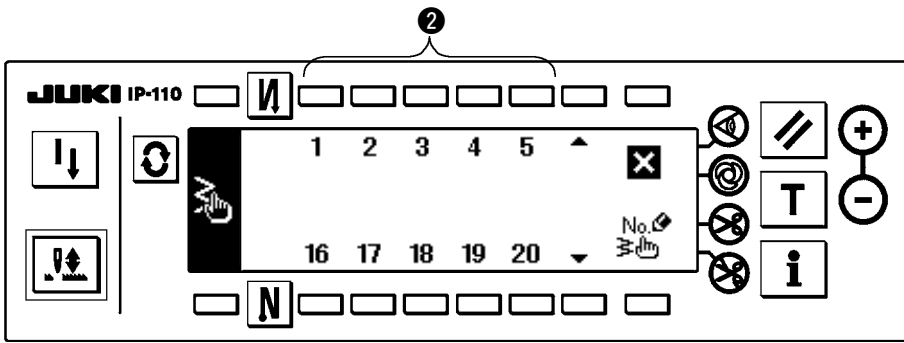

- 2) Press switch ② corresponding to the pattern which has been registered in the custom pattern selection pop-up screen.

■ Sewing shape setting screen

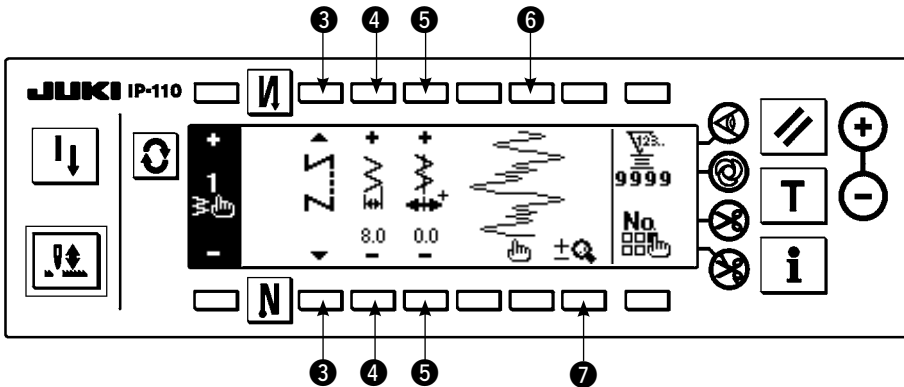

- 3) Press  to display the sewing shape setting screen.

4) Zigzag width, position of stitch base line, etc. of custom pattern can be set in the sewing shape setting screen.



- ③ : Select free stitching, overlapped stitching or programmed stitching.
- ④ : Set the zigzag width with “+” and “-”.
(The whole can be enlarged or reduced taking the inputted left and right positions as reference.)
- ⑤ : Set the position of stitch base line with “+” and “-”.
- ⑥ : Needle entry position is displayed.
- ⑦ : Total display and partial display of the custom pattern are changed over.

(2) New creation of the custom pattern

Custom pattern is newly created.

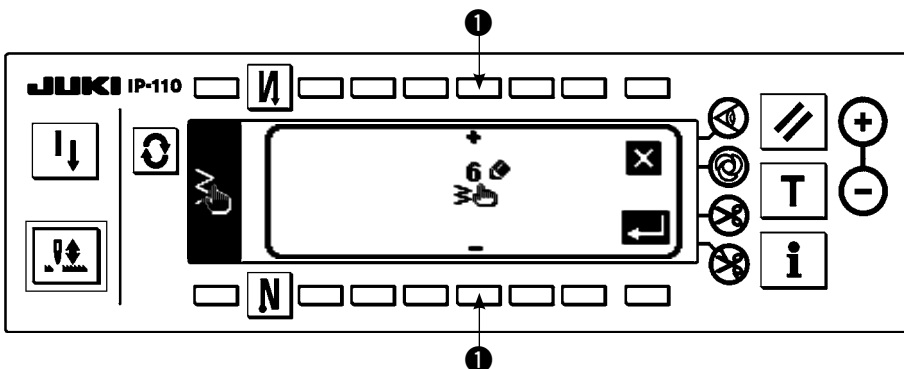
■ New creation pop-up screen



- 1) Press  in the custom pattern selection pop-up screen to display the new creation pop-up screen.
- 2) Nos. which have not been registered at present are displayed in ①. Select the No. you desire to obtain with “+” and “-”.
When  is pressed here, the screen returns to the former one without creating the pattern.
- 3) When  is pressed, new creation is performed.
The No. which has been created is in the selective state. Continue to perform the edit of custom pattern.

(3) Custom pattern edit

1) Press switch of  in the sewing shape setting screen to move to the custom pattern edit screen.

■ Custom pattern edit screen

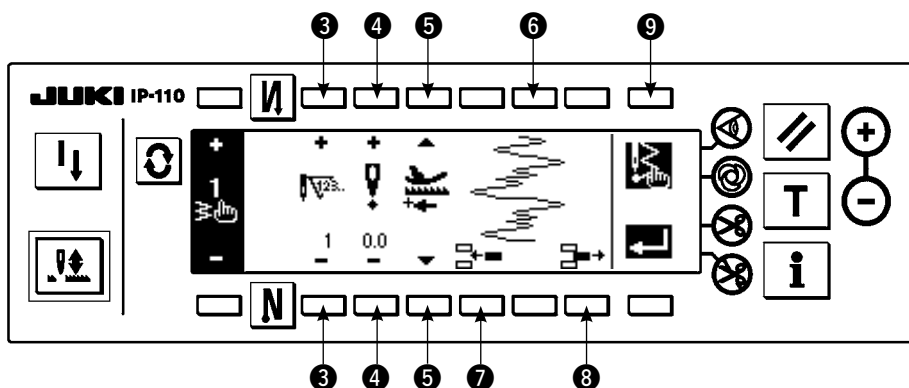

2) Set the needle entry position and sewing direction of each step in the custom pattern edit screen.



- ③ : Set the step with “+” and “-”.
- ④ : Set the value of needle entry point from the center of zigzag with “+” and “-”. “+” value comes on the right side and “-” value on the left side.
- ⑤ : Set the feed amount with “+” or “-”.
- ⑥ : Needle entry position is displayed. (In display of the needle entry position, all positions are displayed as the normal direction.)
- ⑦ : Insert needle entry point 0.0 for one stitch to the existing step. Then the stitches move backward one stitch by one stitch.
* It is not possible to insert it when the number of total stitches is 500 stitches.
- ⑧ : Delete one stitch of the needle entry of the existing step. Then the stitches move forward one stitch by one stitch.
* It is not possible to delete it when the number of total stitches is “1” stitch.

3) When setting is completed up to the last step, proceed to the next step, press ⑨  and put END mark .

* When the number of stitches of the last step is 500 stitches, it is not necessary to set “END” mark .

4) When the setting is completed, press  key to determine.



When the power source is turned OFF without pressing  key, the inputted data returns to the former one. When you desire to determine the data, be sure to press  key.



When the setting of the feed direction of the custom pattern is set to the reverse direction, the max. speed is limited in accordance with the feed amount used.

(4) Pattern sewing registration, custom pattern copy and custom pattern deletion of the custom pattern

■ Pop-up screen of pattern registration, copy and deletion of custom pattern

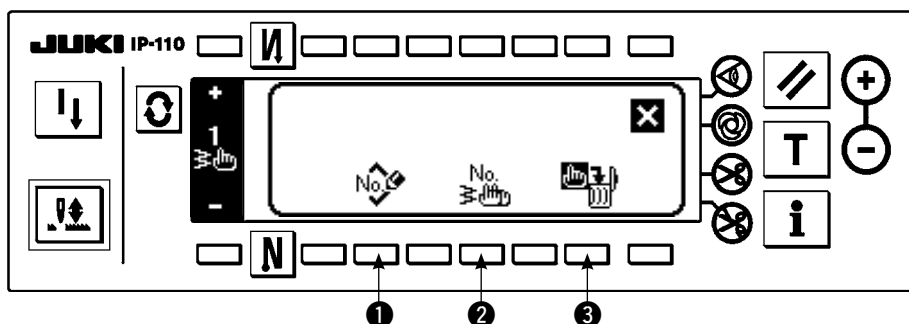

Press  in the sewing shape setting screen, and the pop-up screen of pattern registration, copy and deletion of custom pattern appears. Then pattern registration, copy and deletion of the custom pattern can be performed.

○ Registration of pattern

■ Registration pop-up screen

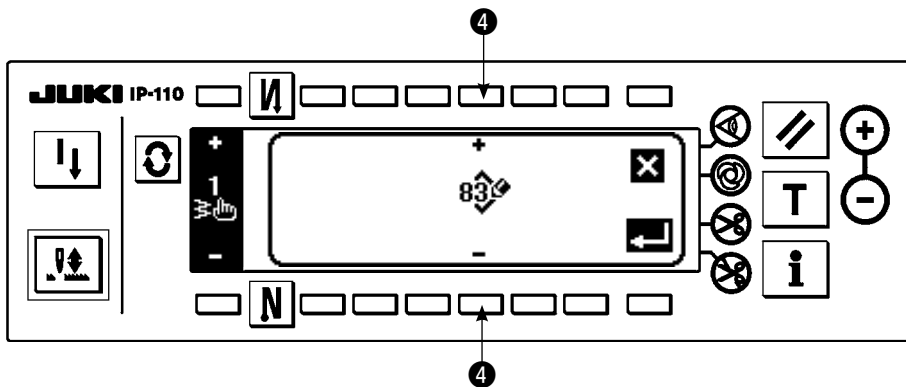

1) Press  ① in the pop-up screen of pattern registration, copy and deletion of custom pattern.

2) Select the pattern No. you desire to register with ④ in the registration pop-up screen.

When  is pressed here, the screen returns to the former one without registering the pattern.

3) When  is pressed, registration is performed.

After registration, the registered pattern is in the selective state.

○ How to copy

■ Copy pop-up screen

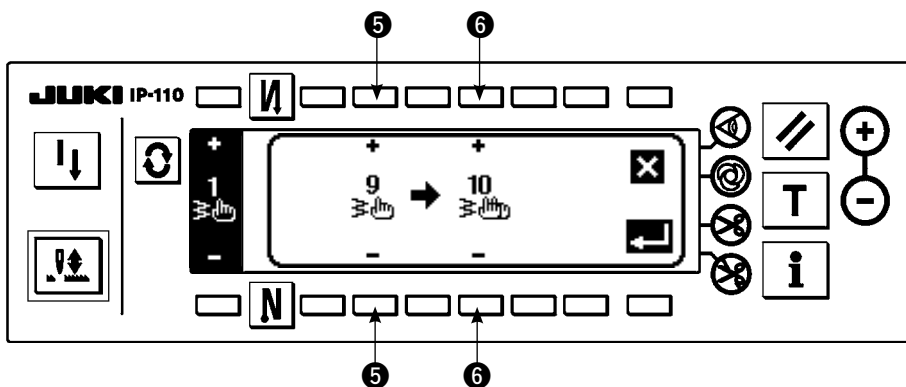



1) Press  ② in the pop-up screen of pattern registration, copy and deletion of custom pattern.

2) Copy pop-up screen is displayed.

⑤ : Select the custom pattern of copy source with “+” and “-”. (It is possible to select only No. which has been registered.)

⑥ : Select the custom pattern of copy destination with “+” and “-”. (It is possible to select only No. which has been not registered.)

When  is pressed here, the screen returns to the former one without performing copy.

3) When  is pressed, copying is performed.

When copying is performed, the No. which is selected as copy destination is in the selective state.

○ How to delete

■ Deletion pop-up screen

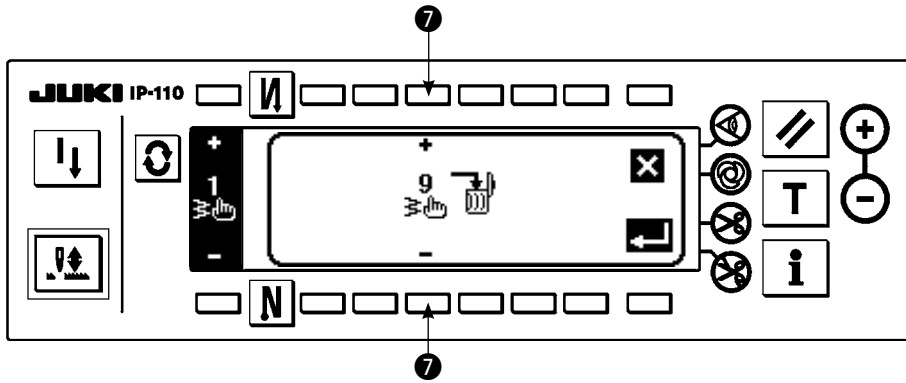

- 1) Press ③ in the copy pop-up screen and the deletion pop-up screen to display the deletion pop-up screen.
- 2) Select the pattern No. you desire to delete in the deletion pop-up screen.
 - ⑦ : Select the pattern to be deleted with “+” and “-”.
 When is pressed here, the screen returns to the former one without deleting.
- 3) When is pressed, deletion is performed.

Once the data is deleted, it does not return to the former one. Be sure to press after carefully checking the data.

When the number of registered pieces is one, deletion cannot be performed. When you desire to delete it, perform deletion after creating another No.
The custom pattern registered in the pattern cannot be deleted.

6-11. Condensation Custom







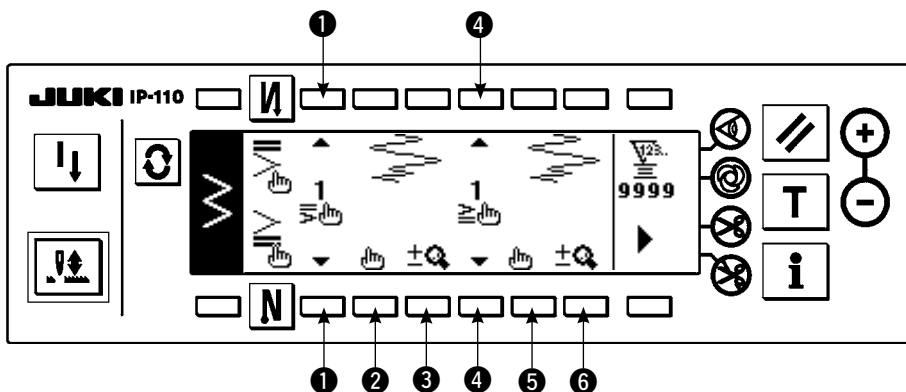

Standard delivery level of the key lock is “1”. When the level of the key lock is the case other than “0”, be sure to change the level to “0” to perform the operation below.

Condensation custom can perform condensation by specifying free needle entry position. Condensation custom patterns can be created up to as many as 64 steps. As many as 20 patterns can be registered at the sewing start and the sewing end respectively.

(1) Condensation custom setting

■ Reverse feed stitching setting (condensation custom) screen





- 1) Press  to display the reverse feed stitching setting screen.
- 2) Select the shape of condensation in the reverse feed stitching screen.
 - ① : Select the shape of condensation at sewing start from among 1 to 20.
Standard condensation , 2-point-condensation  and condensation customs  to  are changed over and displayed in the display section.
 - ④ : Select the shape of condensation at sewing end from among 1 to 20.
Standard condensation , 2-point condensation  and condensation customs  to  are changed over and displayed in the display section.
 - ② , ⑤ : Needle entry position is displayed when selecting the condensation custom.
 - ③ , ⑥ : Total display and partial display of the condensation custom pattern are changed over.

(2) Condensation custom edit

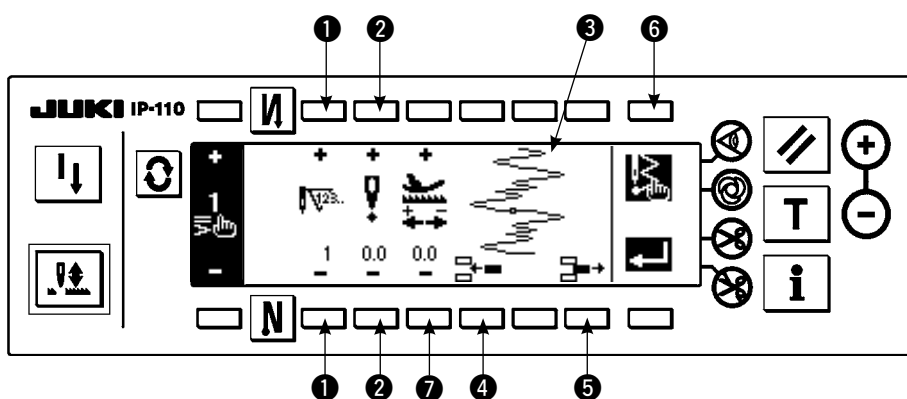
■ Condensation custom edit screen



- 1) Press  to display the reverse feed stitching setting screen.
- 2) Press  in the reverse feed stitching setting screen to move to the condensation custom edit screen.

- 3) Set the needle entry position for each step in the condensation custom edit screen.
 - ① : Set the step with “+” and “-” key.
 - ② : Set the value of needle entry point from the center of zigzag with “+” and “-”. “+” value comes on the right side and “-” value on the left side.
 - ③ : Needle entry position is displayed.
 - ④ : Insert needle entry point 0. 0 for one stitch to the existing step. Then the stitches move backward one stitch by one stitch.
* It is not possible to insert it when the number of total stitches is 64 stitches.
 - ⑤ : Delete one stitch of the needle entry of the existing step. Then the stitches move forward one stitch by one stitch.
* It is not possible to delete it when the number of total stitches is “1” stitch.
 - ⑦ : Set the feed amount with “+” and “-”.

■ Reverse feed stitching setting screen

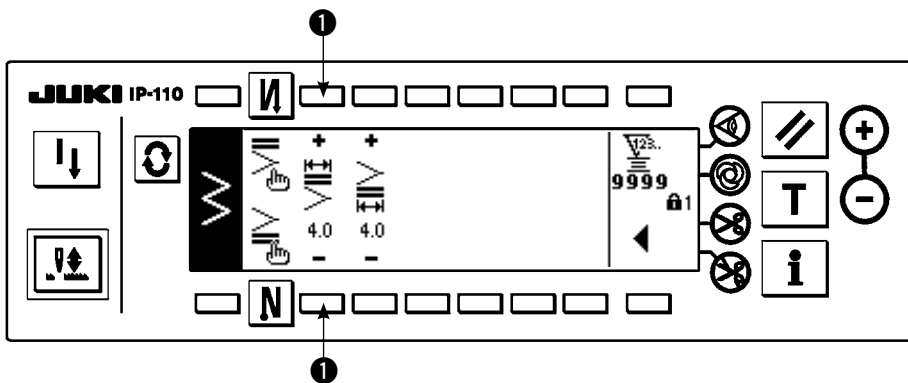

The second screen of the reverse feed stitching setting is explained, taking the example of the input of condensation custom at sewing start (width 4mm for 2-step zigzag stitch).

Example) Condensation custom at sewing start Width 4 mm for 2-step zigzag stitch

	Needle entry	1th stitch	2th stitch	3th stitch	4th stitch	5th stitch	6th stitch	7th stitch	8th stitch	9th stitch	10th stitch	11th stitch
	Input value	-2.0	-0.7	0.6	2.0	0.6	-0.7	-2.0	-0.7	0.6	2.0	END
	Feed amount	0.1	0.1	0.1	0.1	0.1	0.1	0.1	0.1	0.1	0.1	

① Input the data of the list in the condensation custom edit screen.

② Set 4 mm at ① in the 2nd screen of reverse feed stitching setting.

* By changing at ①, the inputted needle entry (width shown at ②) can be enlarged/reduced.

Caution When the power source is turned OFF without pressing key, the inputted data returns to the former one. When you desire to determine the data, be sure to press key.

Important The feeding directions of the condensation custom patterns are all in the reverse feed directions.

6-12. Pattern stitching



Standard delivery level of the key lock is “1”. When the level of the key lock is the case other than “0”, be sure to change the level to “0” to perform the operation below.

The respective shapes of straight stitch, 2-step zigzag, 3-step zigzag, 4-step zigzag, scallop, blind stitch, T stitch, patterns 1 to 4 and custom can be registered in the pattern.

Patterns, the zigzag width of which is different from each other, and those, the positions of the stitch base line of which are different from each other can be changed over and used without re-setting the data even in case of the same zigzag shape by registering as patterns. Continuous stitching or cycle stitching can be set by using the registered pattern.

It is possible to register as many as 99 patterns.

(1) Setting the pattern stitching

Example) Scallop stitching

■ The second screen of the sewing shape list

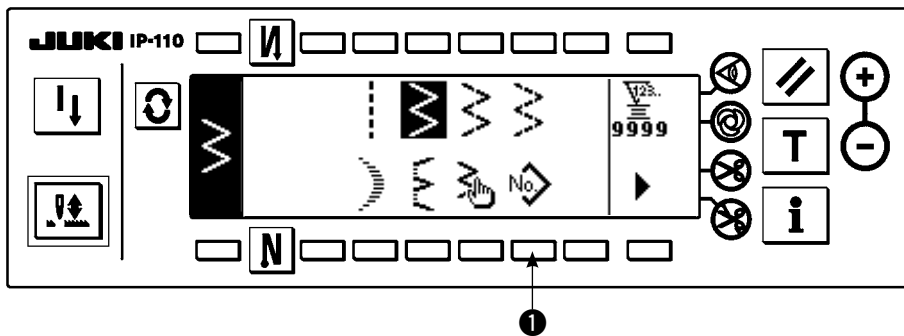

- 1) Select **No.** ① in the second screen of the sewing shape list.

■ Pattern selection pop-up screen

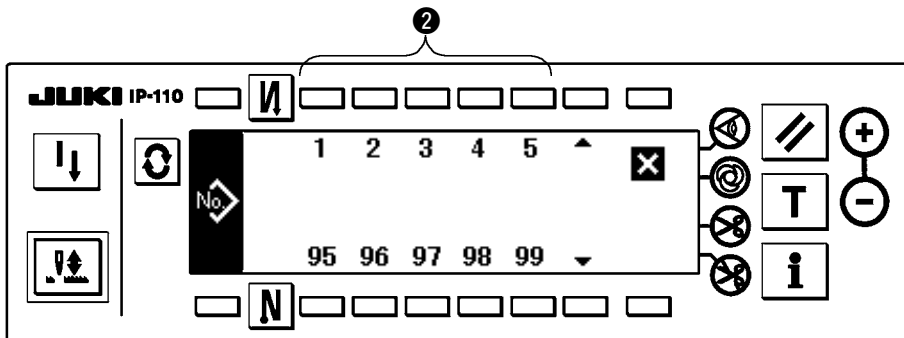

- 2) Press switch ② corresponding to the sewing which has been registered, or the pattern you desire to edit in the pattern selection pop-up screen.
- 3) Press **↺** to display the sewing shape setting screen.

■ Sewing shape setting screen

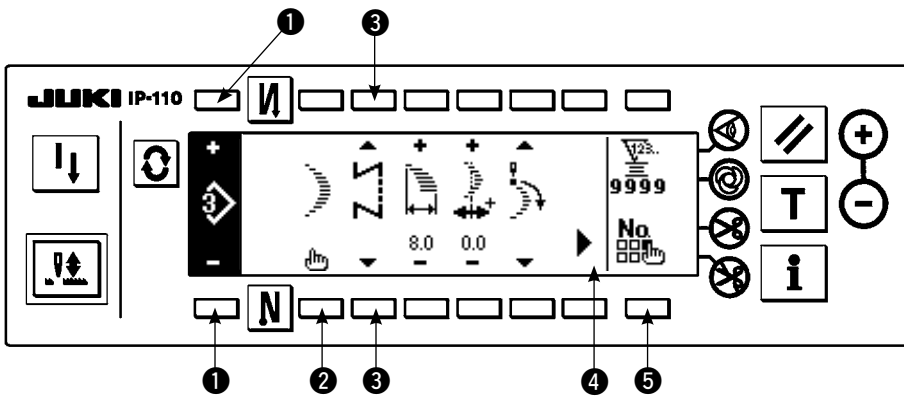

* When there is the second screen, ► 4 is displayed.

4) Setting of the respective items can be performed in the sewing shape setting screen.

Shape	Zigzag width	Position of stitch base line	Reverse feed amount	Normal feed amount	Compensation value	Position at sewing start	Stop position	Number of stitches of blind stitch
Straight	—	○	○	○	—	—	—	—
2-step zigzag	○	○	○	○	—	○	○	—
3-step zigzag	○	○	○	○	—	○	○	—
4-step zigzag	○	○	○	○	—	○	○	—
Scallop	○	○	○	○	—	○	○	—
Blind stitch	○	○	○	○	—	—	—	○
T stitch, left	○	○	—	○	○	○	○	—
T stitch, right	○	○	—	○	○	○	○	—
Pattern 1	○	○	—	○	○	○	○	—
Pattern 2	○	○	—	○	○	○	○	—
Pattern 3	○	○	—	○	○	○	○	—
Pattern 4	○	○	—	○	○	○	○	—
Custom	○	○	—	—	—	—	—	—

① : Pattern No. which has been registered can be selected with “+” and “-”.

② : Select the pattern shape. Sewing shape can be changed by the pattern No. which is being selected at present.



When the sewing shape is changed, the respective setting data return to the initial values.

③ : Select the kind of stitching. Free stitching and overlapped stitching can be selected.

(2) Registering the pattern stitching

It is possible to register at the time of free stitching and overlapped stitching.

Select in advance the shape you desire to register from the sewing shape list screen.

Example) Scallop stitching

■ Sewing shape setting screen

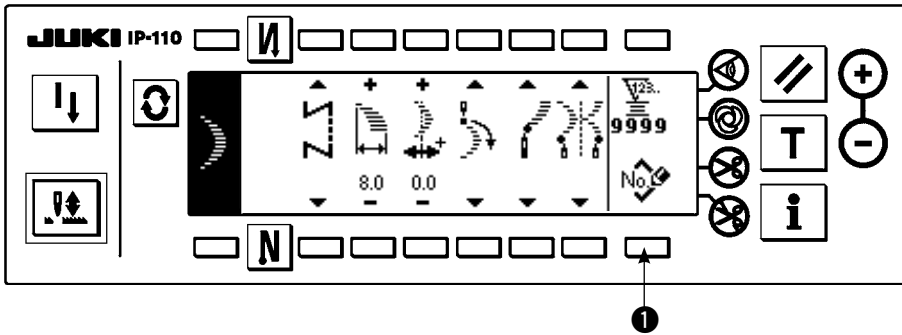

1) Press to display the sewing shape setting screen.

2) Press ① to display the new registration pop-up screen in the sewing shape setting screen.

■ New registration pop-up screen

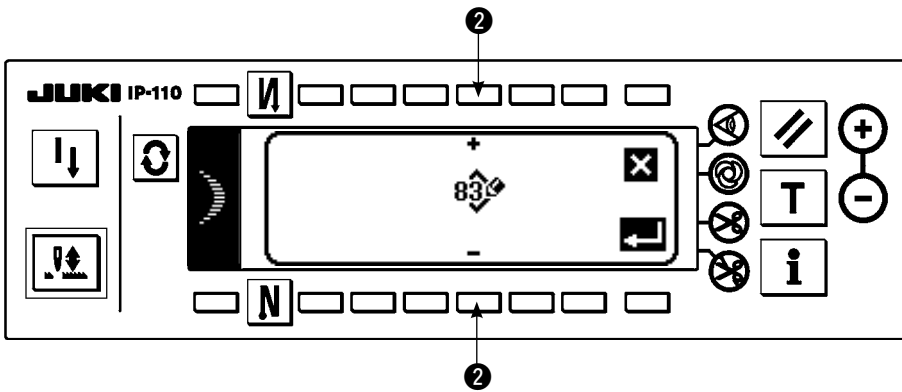

3) Select the pattern No. to which you desire to register with ② in the new registration pop-up screen.

When is pressed here, the screen returns to the former one without performing the registration.

4) When is pressed, registration is performed.

The registered pattern is in the selective state after registration has been performed.

(3) Copy and deletion of the pattern stitching

Press ⑤ in the sewing shape setting screen to display the copy and deletion pop-up screen. Then copy and deletion of the pattern stitching can be performed.

○ How to copy

■ Copy and deletion pop-up screen

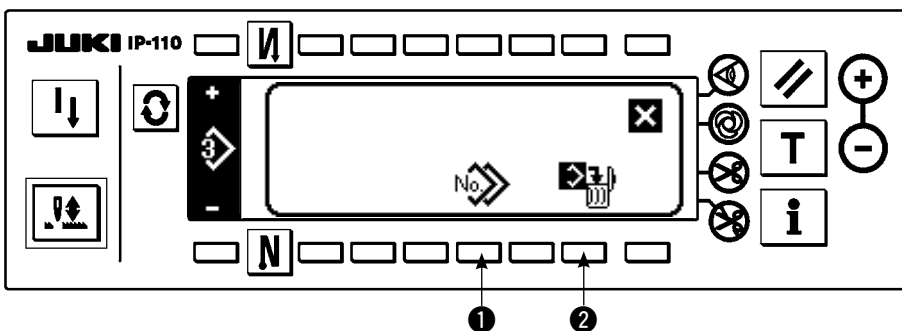

1) Press ① in the copy and deletion pop-up screen to display the copy pop-up screen.

■ Copy pop-up screen

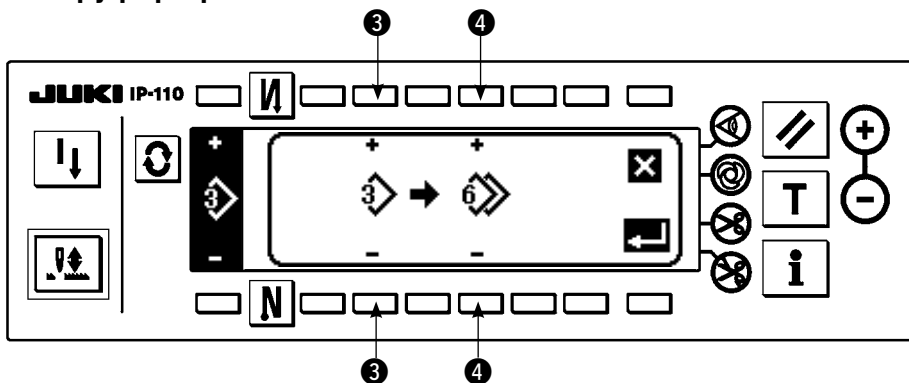

2) Set the pattern Nos. of the copy source and copy destination in the copy pop-up screen.

③ : Select pattern No. of the copy source with “+” and “-”. (Registered Nos. only can be selected.)

④ : Select pattern No. of the copy destination with “+” and “-”. (Non-registered Nos. only can be selected.)

When **X** is pressed here, the screen returns to the former one without performing copy.

3) When **↵** is pressed, copy is performed.

No. of the copy destination is in the selective state after copy has been performed.

○ How to delete

■ Deletion pop-up screen

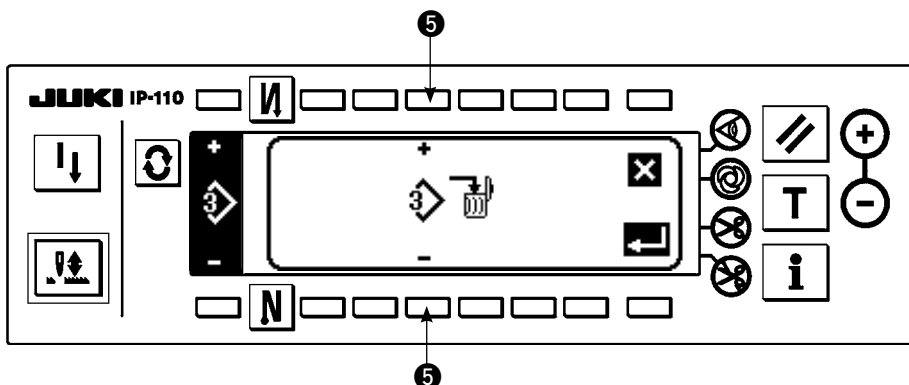

1) Press **🗑️** ② in the copy and deletion pop-up screen to display the deletion pop-up screen.

2) Select pattern No. you desire to delete in the deletion pop-up screen.

⑤ : Select the pattern to be deleted with “+” and “-”.

When **X** is pressed here, the screen returns to the former one.

3) When **↵** is pressed, deletion is performed.



Once the deletion is performed, the data is not restored.
Be sure to carefully check before pressing **↵**.



When the number of registered pieces is one, deletion cannot be performed. When you desire to delete it, perform deletion after creating another No.
The pattern used in continuous stitching or cycle stitching cannot be deleted.

6-13. Continuous stitching



Standard delivery level of the key lock is “1”. When the level of the key lock is the case other than “0”, be sure to change the level to “0” to perform the operation below.

The continuous stitching is a function created by supposing the case where the different patterns are connected and sewn, or the case where the sewing is performed beyond max. number of stitches per pattern, 500 stitches. Therefore, the connected patterns are recognized as one pattern.

Continuous stitching can sew the different zigzag patterns in combination.

Changeover of the respective patterns can be set with the number of stitches.

Continuous stitching can combine as many as 20 steps and 500 stitches per step can be set. In addition, up to 10 patterns can be registered.

To perform the continuous stitching, it is necessary to register in advance the pattern to be used in each step.

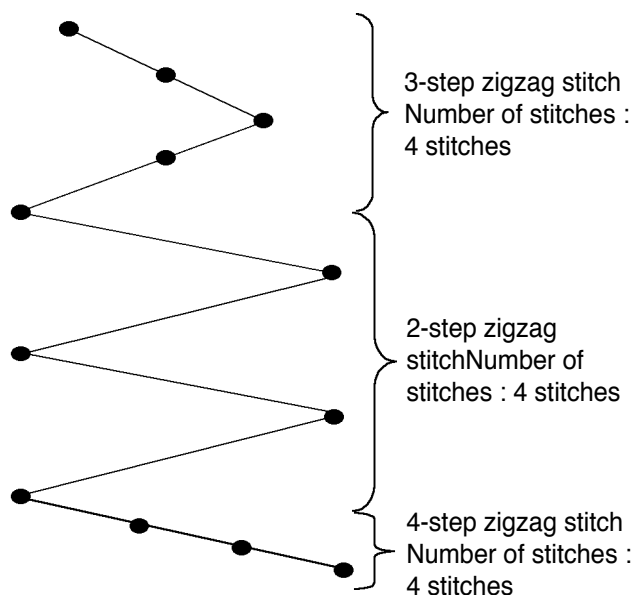

Example) When you desire to create the needle entry positions as shown in the figure below.

- 1) Register in advance 2-step zigzag stitch at pattern 1, 3-step zigzag stitch at pattern 2, and 4-step zigzag stitch at pattern 3.
- 2) Set the number of stitches as shown in the table below.

No. of step	Pattern No.	Number of stitches
1	2	4
2	1	4
3	3	4

- 3) When “END” mark is set to the 4th step, registration has been completed.

(1) New creation of the continuous stitching

Continuous stitching pattern can be newly created.

■ New creation pop-up screen

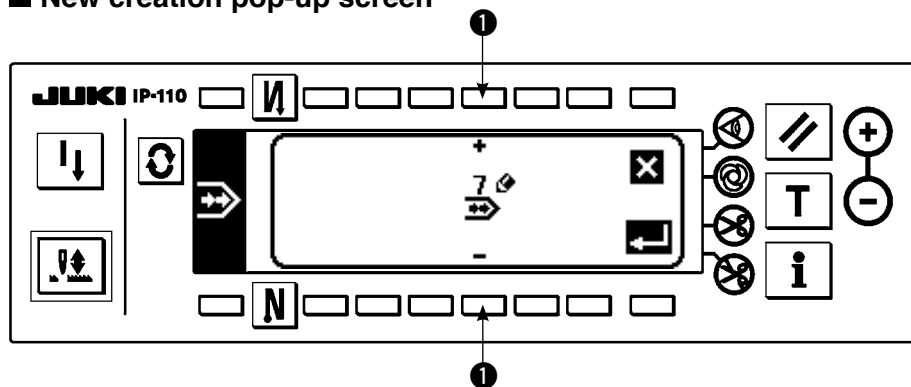

- 1) Press in the continuous stitching selection pop-up screen to display the new creation pop-up screen.
- 2) Nos. which have not been registered at present are displayed in ❶. Select the No. you desire to obtain with “+” and “-”.

When is pressed here, the screen returns to the former one without creating the pattern.

- 3) When is pressed, new creation is performed.

The No. which has been created is in the selective state. Continue to perform the continuous stitching edit.

(2) Continuous stitching edit

■ The second screen of the sewing shape list

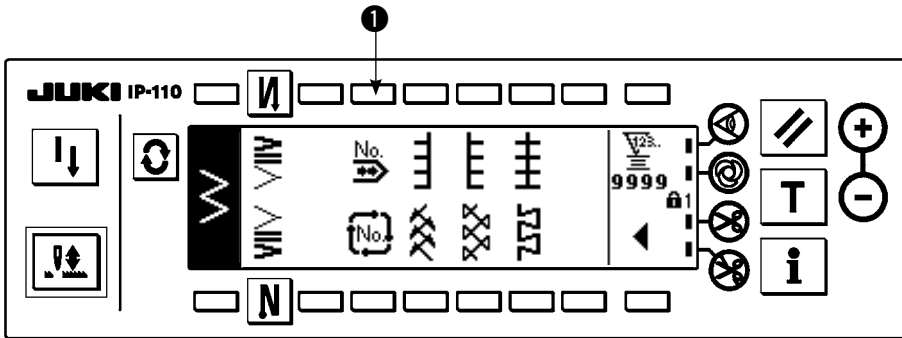

■ Continuous stitching selection pop-up screen

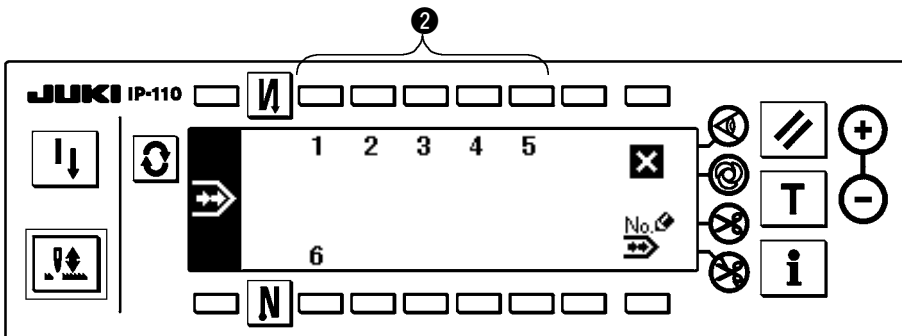

1) Select  ① in the second screen of the sewing shape list.

2) Press switch ② corresponding to the sewing which has been registered, or the pattern you desire to edit in the continuous stitching selection pop-up screen.

■ Continuous stitching setting screen

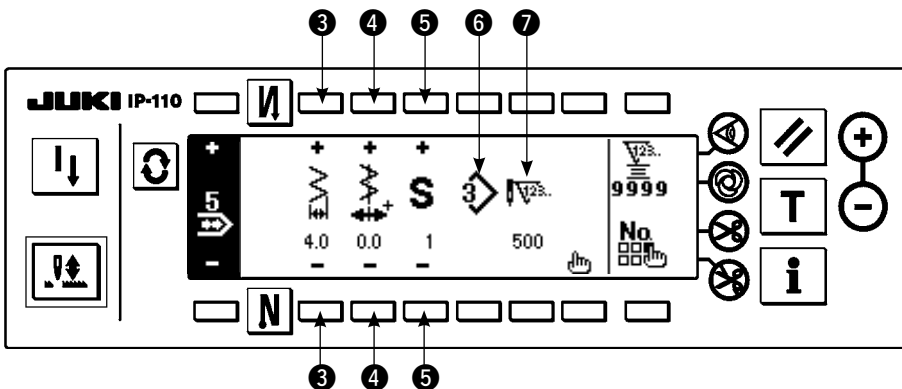

3) Press  to display the continuous stitching setting screen.

4) Zigzag width and position of stitch base line can be set in the continuous stitching setting screen.

③ : Set zigzag width after combining with “+” and “-”.

④ : Set the position of stitch base line with “+” and “-”.

⑤ : Select the registered step with “+” and “-”.

⑥ : Pattern No. of the step which is being selected at present is displayed. Editing cannot be performed.

⑦ : Number of stitches of the step which is being selected at present is displayed. Editing cannot be performed.

5) Press  to move to the continuous stitching edit screen.

■ Continuous stitching edit screen

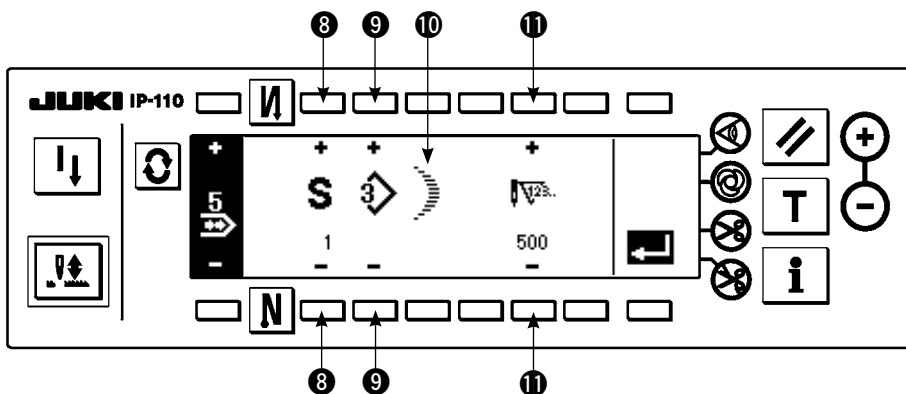

6) Select the pattern and set the number of stitches in each step in the continuous stitching edit screen.

- ⑧ : Set the step with “+” and “-”. As many as 20 steps can be set.
- ⑨ : Set the pattern No. with “+” and “-”. (Registered pattern only can be set.)
- ⑩ : Sewing shape of the pattern which has been selected at ⑨ is displayed.
- ⑪ : Set the number of stitches with “+” and “-”. As many as 500 stitches can be set.

7) When setting up to the last step is completed, proceed to the next step, press ⑨ and put END mark .

* When the last step is 20, it is not necessary to set “END” mark .

8) When all settings have been completed, press  key to determine.



When the power source is turned OFF without pressing  key, the inputted data returns to the former one. When you desire to determine the data, be sure to press  key.

(3) Copy and deletion of the continuous stitching

Press in the continuous stitching setting screen, and the copy and deletion of continuous stitching pop-up screen is displayed. The copy and deletion of the continuous stitching pattern can be performed.

○ How to copy

■ Copy and deletion of continuous stitching pop-up screen

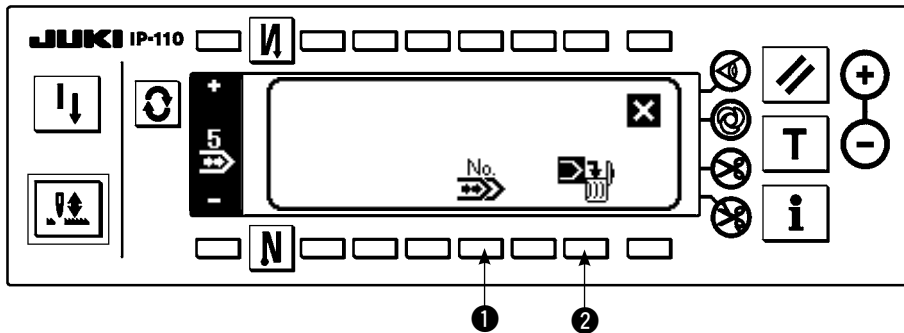

- 1) Press ① in the copy and deletion of continuous stitching pop-up screen.
- 2) The copy pop-up screen is displayed.

③ : Select the continuous stitching pattern of the copy source with “+” and “-”.

④ : Select the continuous stitching pattern of the copy destination with “+” and “-”.

■ Copy pop-up screen

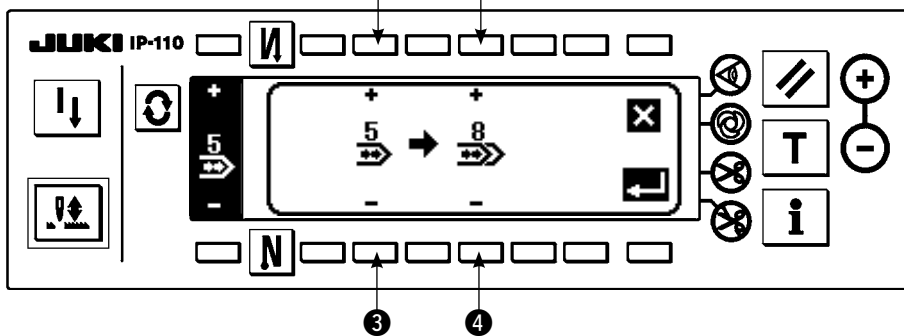

When is pressed

here, the screen returns to the former one without performing copy.

- 3) When is pressed, copy is performed. The No. which is selected to the copy destination is in the selective state after copy has been performed.

○ How to delete

■ Deletion pop-up screen

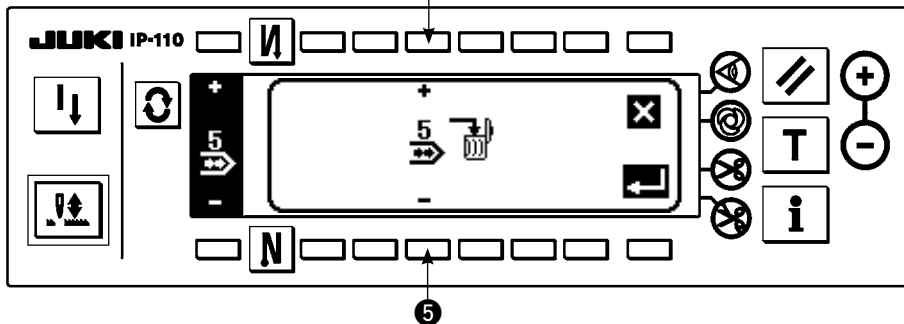

- 2) The deletion pop-up screen is displayed.

⑤ : Select the continuous stitching pattern to be deleted with “+” and “-”.

When is pressed here, the screen returns to the former one without performing deletion.

- 3) When is pressed, deletion is performed.



Once the data is deleted, it does not return to the former one. Be sure to press after carefully checking the data.



When the number of registered pieces is one, deletion cannot be performed. When you desire to delete it, perform deletion after creating another No.
The continuous stitching used in cycle stitching cannot be deleted.
Continuous stitching treats the respective patterns as one pattern, and it is not possible to start sewing from the pattern on the way or perform re-sewing.

6-14. Cycle stitching



Standard delivery level of the key lock is “1”. When the level of the key lock is the case other than “0”, be sure to change the level to “0” to perform the operation below.

The cycle stitching is the shape sewing such as label attaching and the like, and a function created by supposing the case where a pattern, each side of which is different, is registered and sewn.

Cycle stitching can change over the different patterns in order and perform the sewing.

In addition, by setting the number of stitches, programmed stitching with different needle entry positions for each step can be performed.

Cycle stitching can be set up to max. 20 steps and 10 kinds can be registered.

To perform the cycle stitching, it is necessary to register in advance the patterns which are used in each step.

(1) New creation of the cycle stitching

Cycle stitching pattern can be newly created.

■ New creation pop-up screen

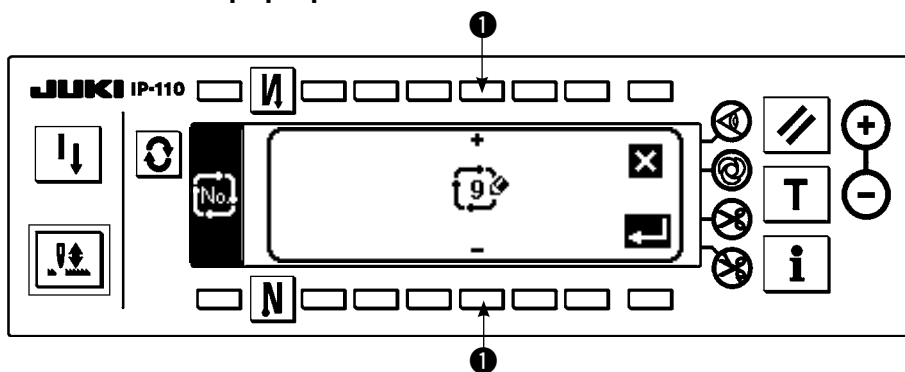

- 1) Press in the cycle stitching selection pop-up screen to display the new creation pop-up screen.

- 2) Nos. which have not registered at present are displayed in ①. Select the No. you desire to obtain with “+” and “-”.

When is pressed here, the screen returns to the former one without creating.

- 3) When is pressed, new creation is performed.

The No. which has been created is in the selective state. Continue to set the cycle stitching.

(2) Cycle stitching edit

■ The second screen of sewing shape list

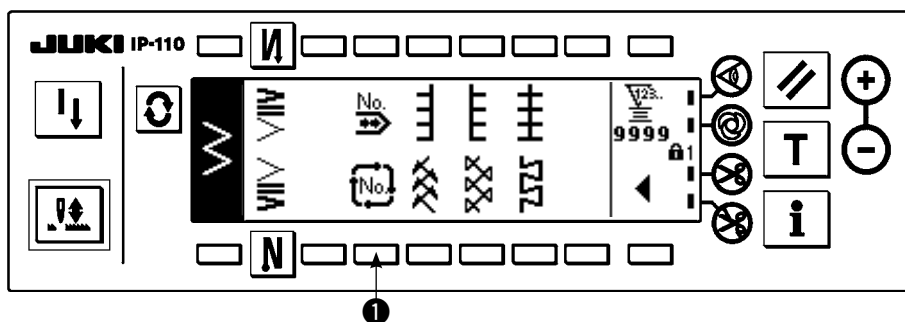

- 1) Select ① in the second screen of the sewing shape list.
- 2) Press switch ② corresponding to the registered sewing, or patterns you desire to edit in the cycle stitching selection pop-up screen.

■ Cycle stitching selection pop-up screen

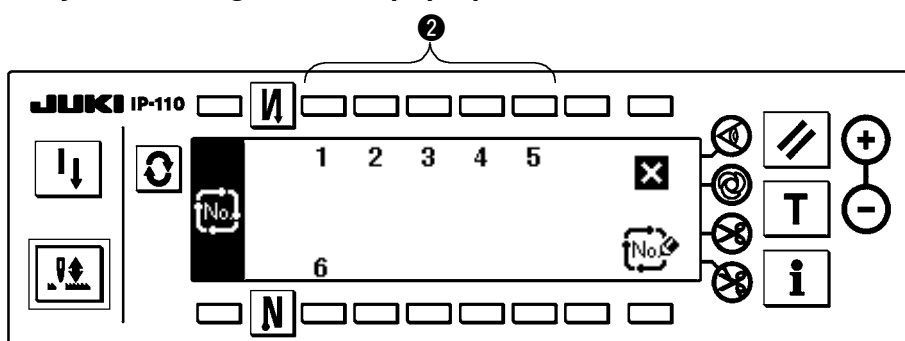

- 3) Press to display the cycle stitching setting screen.

■ Cycle stitching setting screen

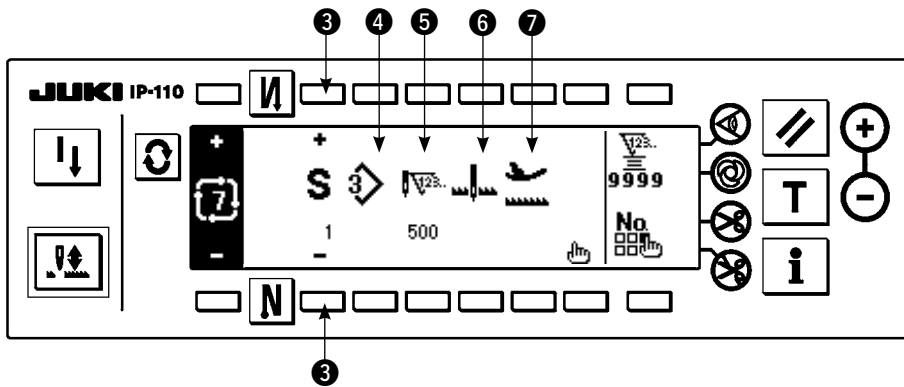

4) Setting of each step can be displayed in the cycle stitching setting screen.

③ : Select the registered steps with “+” and “-”.

* Steps that can be selected are the step that number of stitches is not set and the step that automatic thread trimming is set or that the number of stitches is not set immediately before the step only.

④ : Pattern No. which is being selected at present is displayed. Editing cannot be performed.

⑤ : Stop state of the step which is being selected at present is displayed. Editing cannot be performed.

⑥ : Number of stitches of the step which is being selected at present is displayed. Editing cannot be performed.

⑦ : Position of the presser of the step which is being selected at present is displayed. Editing cannot be performed.

5) Press to display the cycle stitching edit screen.

■ Cycle stitching edit screen

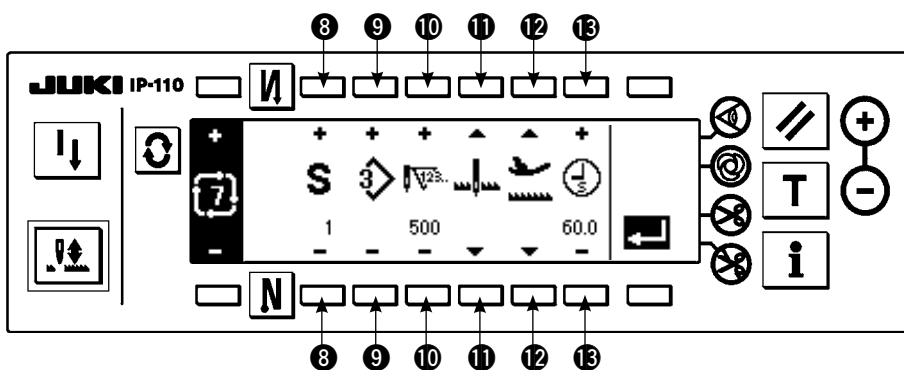

6) Set pattern No., number of stitches, stop position and position of the presser for each step in the cycle stitching edit screen.

⑧ : Set the step with “+” and “-”. As many as 20 steps can be set.

⑨ : Select pattern No. with “+” and “-”. (Pattern Nos. to which patterns have been registered only can be set.)

⑩ : Set the number of stitches with “+” and “-”. As many as 500 stitches can be set.

⑪ : Select the stop state of the step.

① Needle DOWN stop

② Needle UP stop

③ Thread trimming (Effective only when the thread trimming device is provided.)

⑫ : Select the position of the presser. (Only when the auto-lifter is provided.)

① Presser UP stop

② Presser DOWN stop

⑬ : When the presser UP stop is selected at ⑫, set the presser lifting time with “+” and “-”.

7) When setting up to the last step is completed, proceed to the next step, press ⑨ and put END mark .

* When the last step is 20, it is not necessary to set “END” mark .

8) When all settings have been completed, press key to determine.

(3) Copy and deletion of the cycle stitching

Press  in the cycle stitching setting screen to display the copy and deletion of cycle stitching pop-up screen. Then copy and deletion of the cycle stitching pattern can be performed.

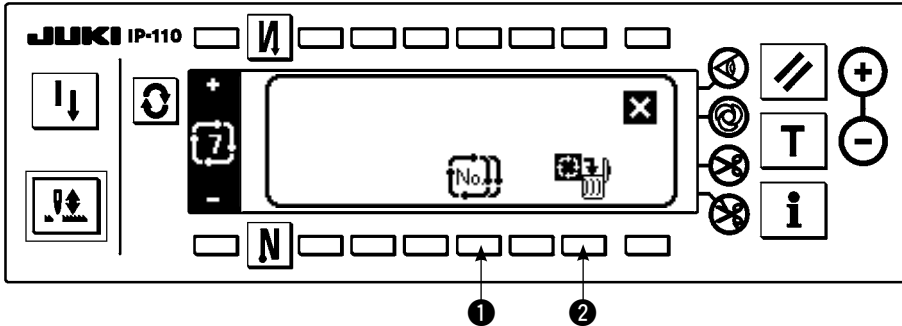

○ How to copy

■ Copy and deletion of cycle stitching pop-up screen

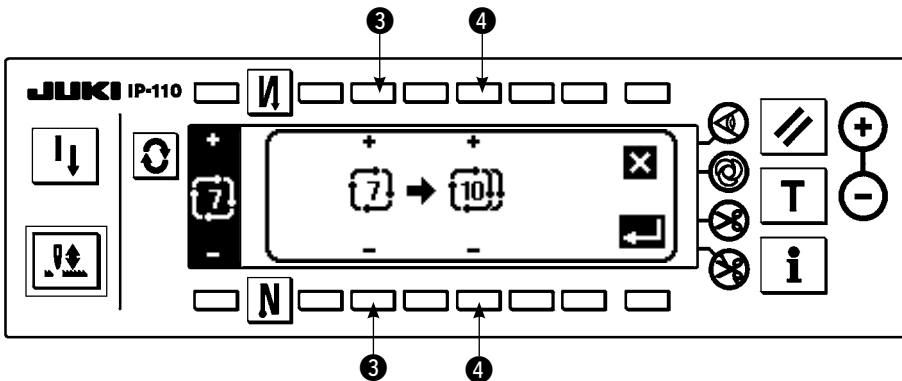

■ Copy pop-up screen



- 1) Press  ① in the copy and deletion of cycle stitching pop-up screen.
- 2) Copy pop-up screen is displayed.
 - ③ : Select the cycle stitching pattern of the copy source with “+” and “-”. (It is possible to select only No. which has been registered.)
 - ④ : Select the cycle stitching pattern of the copy destination with “+” and “-”. (It is possible to select only No. which has been not registered.)When  is pressed here, the screen returns to the former one without performing copy.
- 3) When  is pressed, copy is performed. The No. which is selected to the copy destination is in the selective state after copy has been performed.

○ How to delete

■ Deletion pop-up screen

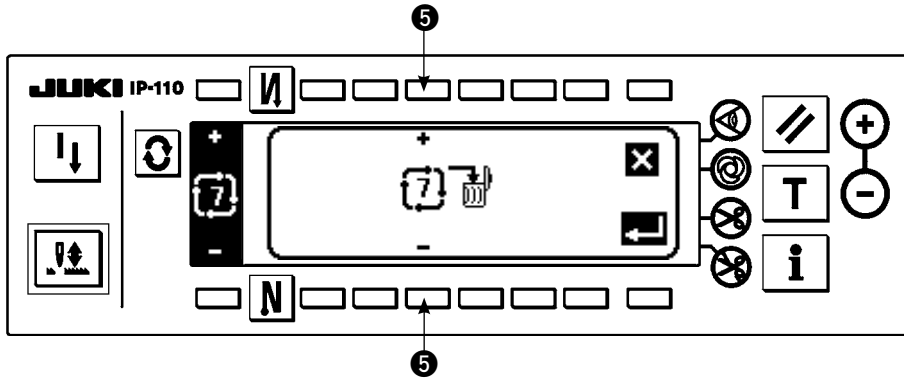

1) Press 2 in the copy and deletion of cycle stitching pop-up screen.

2) Deletion pop-up screen is displayed.

⑤ : Select the cycle stitching pattern to be deleted with “+” and “-”.

When is pressed here, the screen returns to the former one without performing deletion.

3) When is pressed, deletion is performed.



Once deletion is performed, the data is not restored. Be sure to carefully check before pressing .



When the number of registered pieces is one, deletion cannot be performed. When you desire to delete it, perform deletion after creating another No. Cycle stitching treats the respective patterns as one pattern, and it is not possible to start sewing from the pattern on the way or perform re-sewing.

(4) Teaching

Teaching can input the number of stitches of inputting step with the number of stitches which has been actually sewn.

1) Press switch in the cycle stitching edit screen and the teaching mode is obtained.

2) Depress the front part of the pedal to sew until the last stitch of the step is reached.

* At this time, input of the number of stitches cannot be performed by turning the handwheel by hand or using the needle up/down compensating switch.

3) Stop the sewing machine with the pedal in the neutral position and the number of stitches which has been sewn is displayed on ①.

4) Make the sewing machine perform thread trimming and input of the number of stitches for the step is completed.

(Proceeding to the next step and performing teaching cannot be performed.)

Step returns to “1” with thread trimming motion. When inputting the next step with teaching, re-set the step.

■ Teaching screen

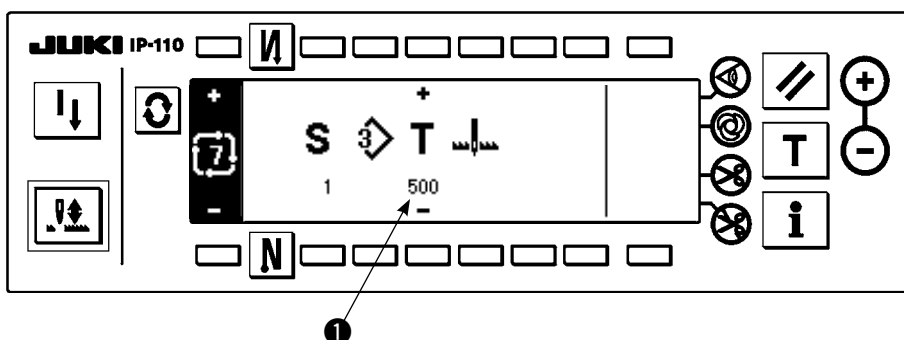

(5) Performing the constant-dimension stitching using the cycle stitching

Constant-dimension stitching, zigzag patterns of which are different from each other in the respective steps can be performed by setting the number of stitches in the cycle stitching.

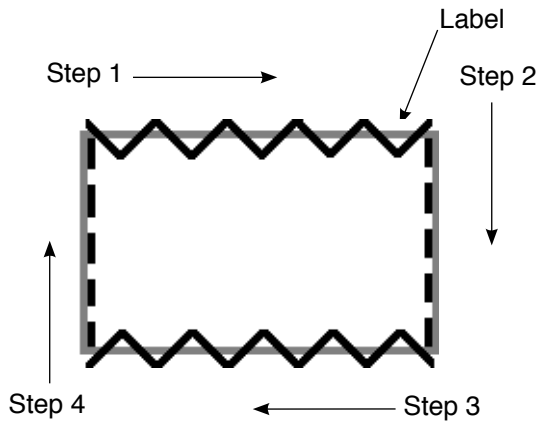

Example) In the process of label attaching, change over the zigzag patterns of constant-dimension stitching of 2-step zigzag stitch and straight stitch as shown in the figure, and perform the constant-dimension stitching.

- 1) Register in advance the 2-step zigzag stitch for the shape of pattern 1 and the straight stitch for the shape of pattern 2.
- 2) Set the number of stitches in each step as shown in the table.

No. of step	Pattern No.	Number of stitches
1	1	100
2	2	50
3	1	100
4	2	50

- 3) Set "END" mark  to the 5th step to complete registration.

6-15. Counter

There are two kinds of the counters, thread trimming counter and bobbin thread counter. Display of the counter is changed over by pressing the switch of ❶.

(1) Thread trimming counter

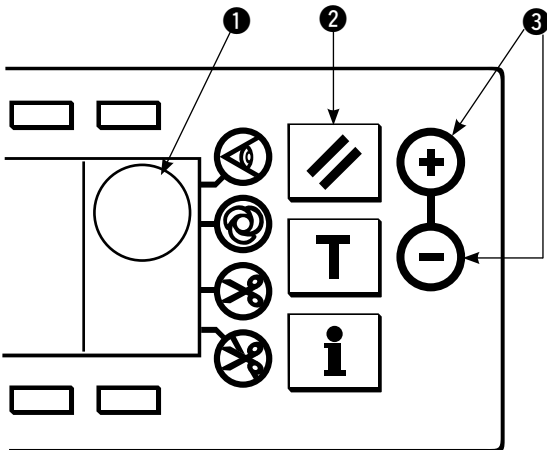

Picture of  is displayed in ❶.

Every time thread trimming is performed, the value increases by 1 count. (0 → 1 → 2 → 9999)

Counter value can be corrected with counter value setting switch ❸.

In addition, the thread trimming counter value returns to "0" when reset switch ❷ is pressed.

(2) Bobbin thread counter

Picture of  is displayed in ❶.

The counter subtracts from the predetermined value set with counter value setting switch ❸ in accordance with the number of stitches of the sewing machine.

When the counter value reaches minus, the buzzer informs about the fact and urges the time of replacement of bobbin thread.

- 1) Press the reset switch to return the display of bobbin thread counter to the initial set value.



Resetting cannot be performed during sewing. Perform thread trimming once.

- 2) Set the initial value with “+” and “-” switch. When the switch is held pressed and the set value exceeds the digit of 100, the set value increases/decreases by 100 unit. When setting the value near to 100 digit, press the switch each time.
- 3) Setting of the initial value is performed, start the sewing.
- 4) When the bobbin thread counter reaches minus and the buzzer beeps, the bobbin thread replacement warning pop-up below appears.

■ Bobbin thread replacement warning pop-up

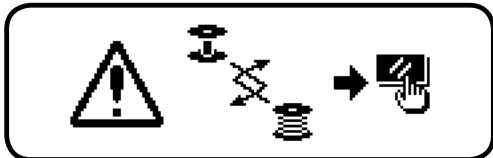

- 5) Press the reset switch to erase the pop-up. Press again the reset switch to return the value to the initial one and re-start the sewing.

* When the thread remaining amount is large, or bobbin thread has run out before the bobbin thread counter reaches minus, adjust the initial set value with “+” or “-” of bobbin thread amount setting switch.

* As a matter of fact, bobbin thread amount changes in accordance with the thickness of cloth or sewing speed. Adjust the counter in accordance with the sewing conditions.

6-16. Information

Setting and checking of various data can be performed with the information. For the information, there are the operator level and the maintenance personnel level.

[Operator level]

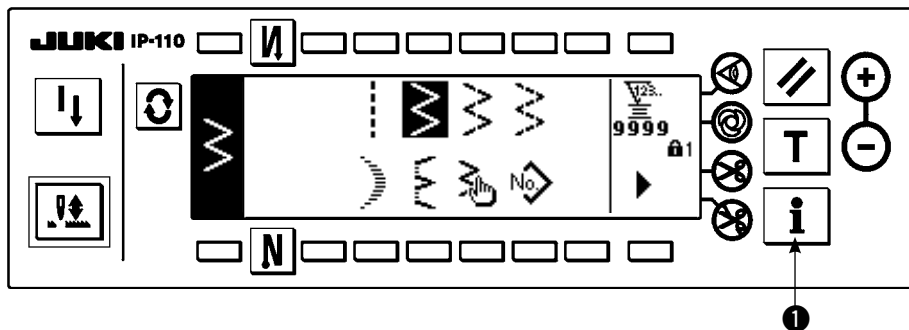

- 1) Turn ON the power. When the needle bar is not in the UP position, turn the handwheel to bring the needle bar to its UP position.
- 2) Press switch ❶ to display the information screen.

■ Information screen (operator level)

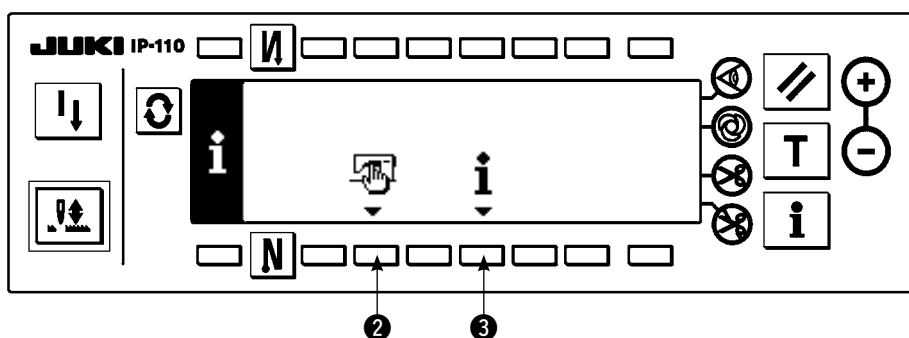

- ❷ : Sewing common data
- ❸ : Sewing management information

(1) Sewing common data

1) Press **2** in the information screen.

■ The first screen of sewing common data setting

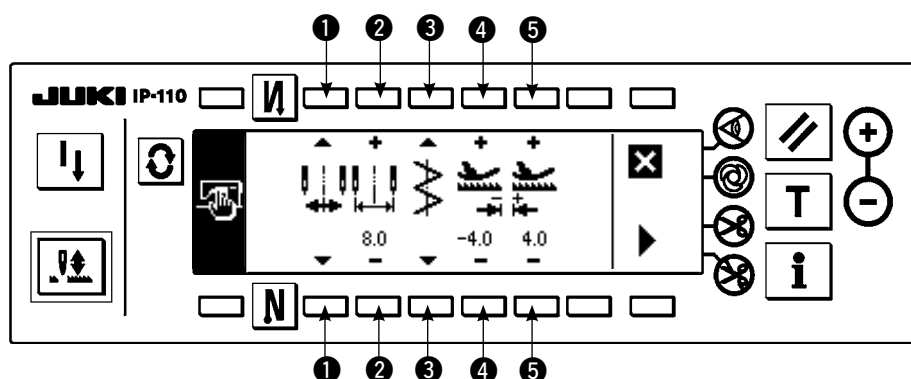

2) Set the items below in the first screen.

1 : Limiting procedure of max. zigzag width limitation
For the limiting procedure of max. zigzag width limitation, there are two settings below.

1) Center 

2) Left/right 

2 : Max.zigzag width limitation value
* Display varies according to the procedure selected in **1**.

3 : Reference of stitch base line
For the reference of stitch base line, there are three settings below.

1) When the center is set in **1** :
Max.zigzag width limitation value (center) 

1) Center 

2) When the left/right is set in **1** :
Max.zigzag width limitation value (right) 

2) Right 

Max.zigzag width limitation value (left) 

3) Left 

4 : Reverse feed limitation value
Set the reverse feed limitation value with “+” and “-” of switch **4**.
In case of the example, set to -4.0.

5 : Normal feed limitation value
Set the normal feed limitation value with “+” and “-” of switch **5**.
In case of the example, set to 4.0.

3) Set the items below in the second screen.

■ The second screen of sewing common data setting

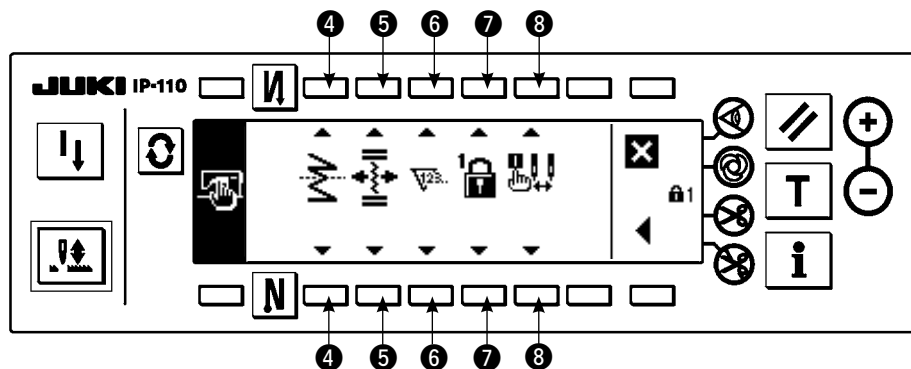



4 : Mirror function setting

Mirror inversion means the function that the reverse pattern stitching is performed after pressing the mirror inversion switch during temporary stop of sewing.

The sewing patterns that the mirror inversion is possible are scallop, custom, continuous stitching and cycle stitching.

For the mirror inversion, there are two settings below.

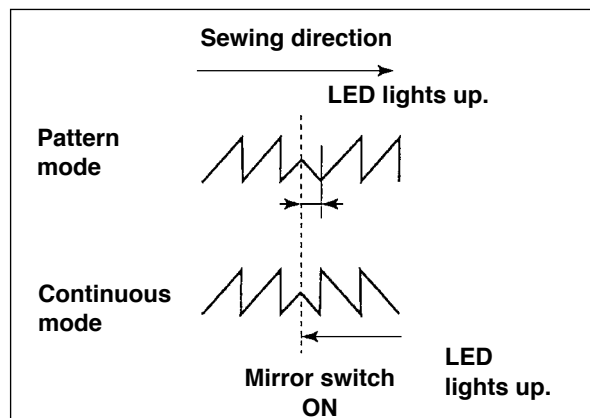

- 1) 1 pattern  : Mirror inversion is “1” pattern only. After completion of inversion pattern, the pattern returns to the original one.
 - 2) Continuous  : The machine continuously operates the inversion pattern after the inversion until thread trimming is performed or, the mirror switch is pressed again.
- * For the details, refer to “Mirror switch”, p.126.





5 : Position of the stitch base line of condensation custom

The mode is the operation mode in terms of the stitch base line of condensation custom when the reference of the stitch base line is set to that of center stitch base line.

For the condensation custom, there are two settings below.

- 1) Travelling together  : This is the mode that travels the positions of stitch base line of condensation custom and zigzag pattern together.
- 2) Fixed  : This is the mode that fixes condensation custom to the input data position.

6 : Counter function

ON  / OFF  of the function of thread trimming counter or bobbin thread counter is set.

When OFF is set, even the counter display is not performed.

7 : Key lock

It is possible to lock the setting switch so that the zigzag width that has been set once or the contents of custom pattern is not changed by mistake. However, it is possible to change ON/OFF of the reverse feed stitch, thread trimming prohibiting switch, specified zigzag stop position and bobbin thread counter.

For the key lock, there are three kinds of settings below.

Level “0”  : All items can be changed.

Level “1”  :  1 is displayed on the right end of the screen.

- Kind of sewing
- Pattern : Change of pattern and registration
- Custom : New creation and edit
- Condensation custom : Edit
- Continuous stitching : New creation, copy, deletion and edit
- Cycle : New creation, copy, deletion and edit cannot be changed.

Level “2”  :  2 is displayed on the right end of the screen.

Items other than reverse feed stitching ON/OFF, thread trimming prohibition switch, specifying zigzag stop position and bobbin thread counter cannot be changed.





Level of the standard delivery is “1”. When changing the locked contents of level “1”, it is necessary to set the level to Level “0” once.

8 : Selection of max. zigzag width limitation display when the power is turned ON

Whether the max. zigzag width limitation value is displayed or not when the power is turned ON can be selected.

Every time the setting switch is pressed, display/non-display is changed over alternately.

- 1) Display 
- 2) Non-display 

(2) Sewing management information

For the sewing management information, there are warning of time of replacement of needle, that of time of cleaning and that of time of replacement of oil as the maintenance management information.

[Maintenance management function]

■ Sewing management information screen

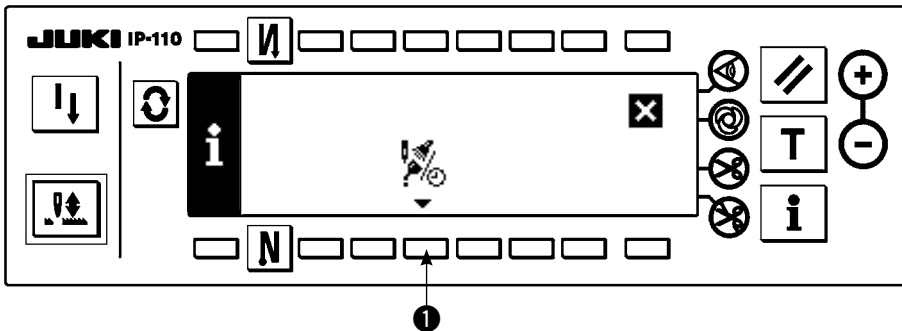

1) Press ❶ to display the maintenance function screen.

■ Maintenance function screen

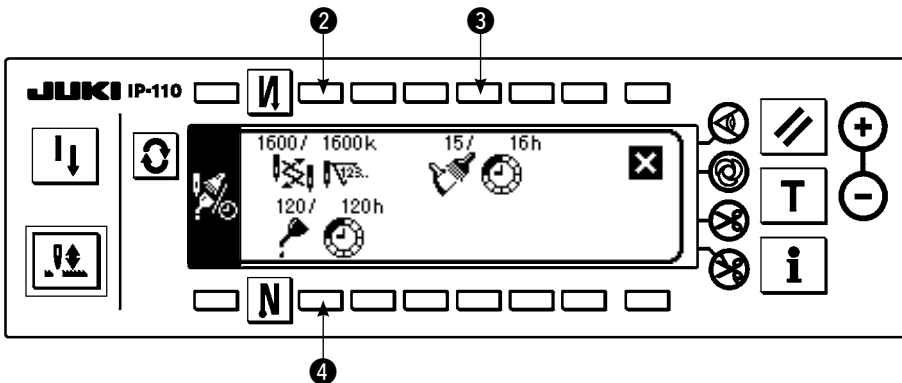

[Explanation of the respective items]

- ❷ Time of replacement of needle Unit : × 1,000 stitches
- ❸ Time of cleaning Unit : Hour
- ❹ Time of replacement of oil Unit : Hour

[Explanation of the contents of display]

(Numerator / denominator)

* Number of remaining stitches up to *thousand stitches / **thousand stitches

Example) Replacement of needle

100 / 1600 k

Time of replacement of needle is informed every 1,600 thousand stitches.
 Time of replacement of needle is informed after 100 thousand stitches.

When ❷, ❸ and ❹ switches are pressed, the clear checking screen is displayed.

■ Clear screen

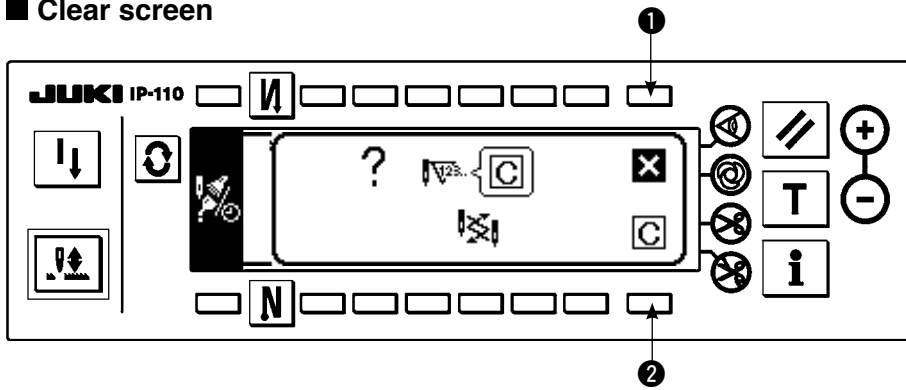

- ① : The screen returns to the maintenance function screen without performing clearing.
- ② : The screen returns to the maintenance function screen after executing clearing.

■ Warning screen

Warning screen is displayed when the warning time is reached.

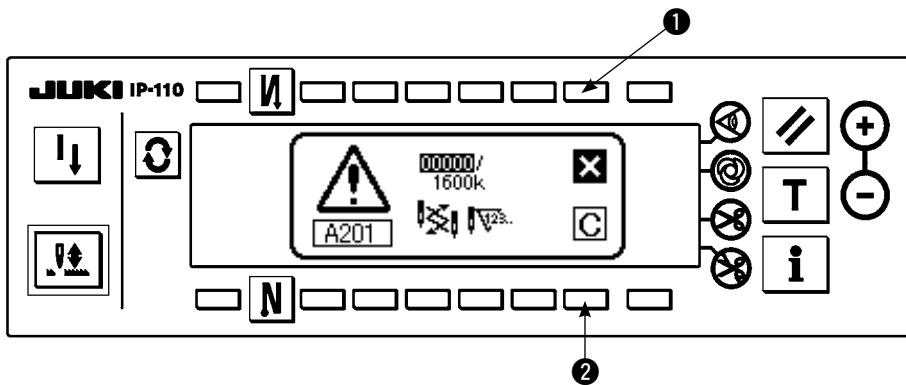

- ① : When ① is pressed, the screen can be cleared. However, the counter itself cannot be cleared. In case of the replacement of needle, the warning screen is displayed at intervals of 10 minutes until clearing is performed. In case of other warnings, the warning screen is displayed at the time of turning ON the power until the counter is cleared.
- ② : When ② is pressed, the screen is cleared and the counter value is cleared as well. From this time, counting starts newly.

[Setting of the warning setting time]

■ Information screen

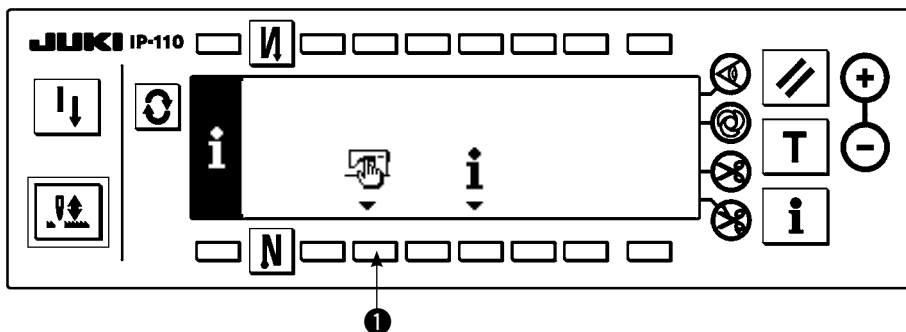

- 1) Press switch ① for approximately three seconds in the information screen.

■ Sewing management information selection screen

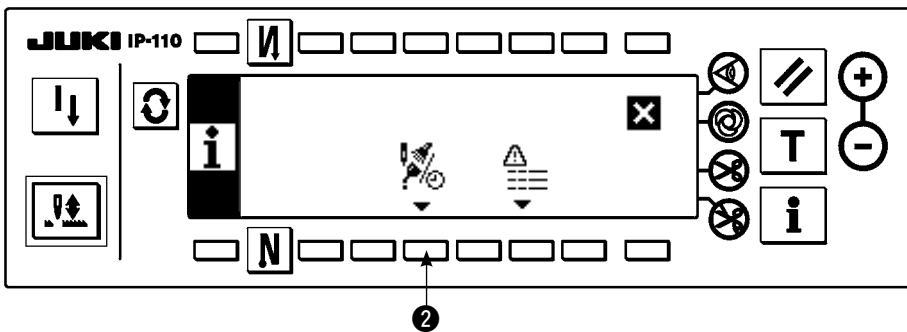

2) Press ② to display the maintenance function screen. (For other functions, refer to the Engineer's Manual.)

■ Maintenance function screen

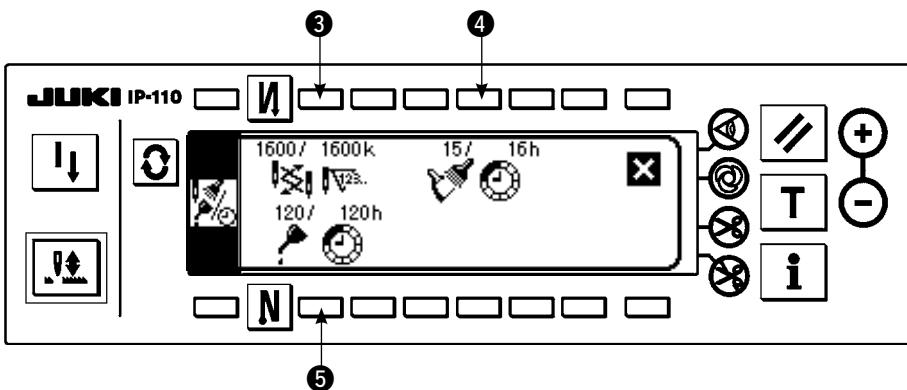

③④ and ⑤ : Warning time input screen is displayed.

3) Set the warning time with ②. Setting time inputted is shown in reverse video at ④.

■ Warning time input screen

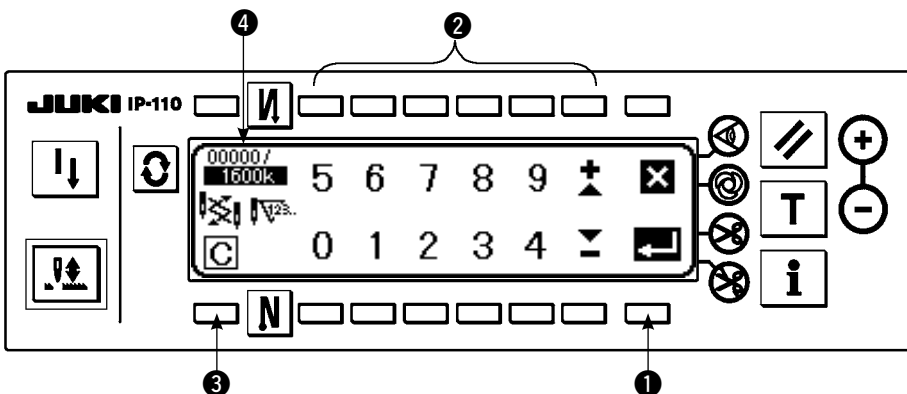

③ Clear screen is displayed.

After inputting the setting time, determine the time with ①.



In case of stopping the warning function, set the set value to "0".

It is possible to individually set replacement of needle, cleaning, and replacement of oil respectively. In case of stopping all, set "0" to each.



Initial value of warning setting time

1 Time of replacement of needle : 0 thousand stitches (kn)

2 Time of cleaning : 0 hours (h) (Current carrying time)

3 Time of replacement of oil : 0 hours (h) (Availability time)

[Maintenance personnel level]

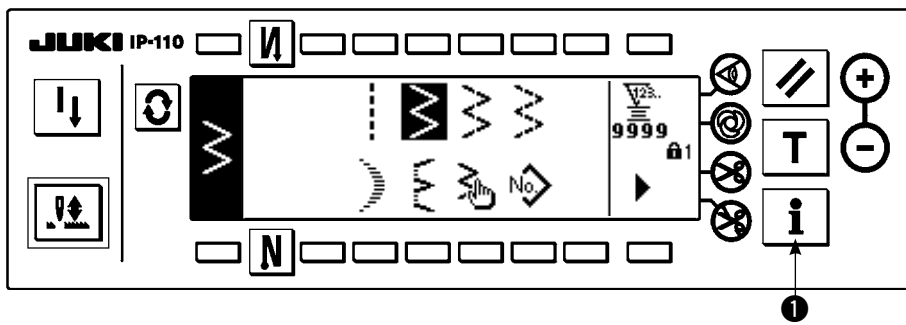

- 1) Turn ON the power. When the needle bar is not in the UP position, turn the handwheel to bring the needle bar to its UP position.
- 2) Press switch ❶ for approximately three seconds to display the information screen.

■ Information screen (Maintenance personnel level)

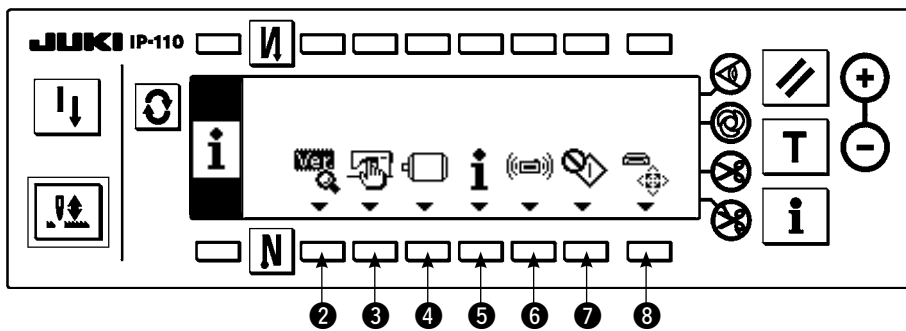

- ❷ : Ver display For the details, refer to the Engineer's Manual.
 - ❸ : Sewing common data
 - ❹ : Function setting Refer to 6-17. Function setting procedure.
 - ❺ : Sewing management information
 - ❻ : Communication mode
 - ❼ : Hook adjusting mode Refer to 8-6. Hook adjusting mode.
 - ❽ : Media format For the details, refer to the Engineer's Manual.
- * When the media format is executed, all of the data that have been recorded at present disappear. Be careful not to use it other than initialization of the media.

(3) Communication mode

The matters below can be performed in the communication mode.

- 1) Sewing machine data server utility (hereafter : SU-1) or vector form (VDT) data from media can be registered to non-registered No. of custom pattern.
 - 2) Custom pattern can be changed to the vector form and be uploaded to SU-1 or the media.
 - 3) Parameter data (EPD) can be overwritten and registered to the condensation custom pattern from SU-1 or the media.
 - 4) Condensation custom pattern can be uploaded to SU-1 or the media.
- * For setting of the communication with SU-1, refer to the Instruction Manual for SU-1.

■ Communication setting screen (download)

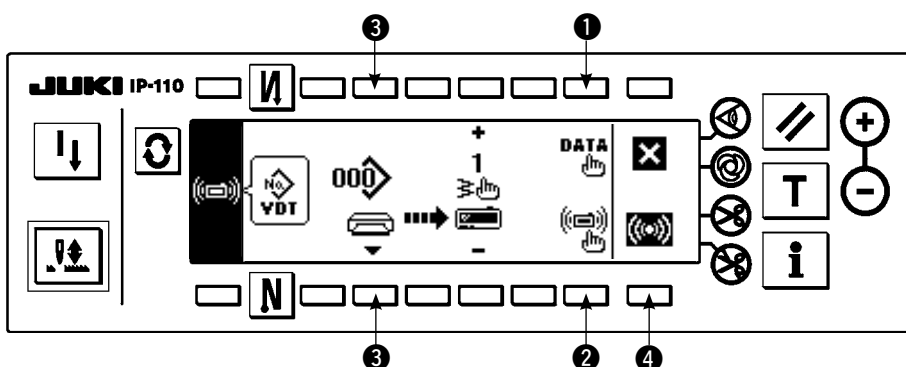

Example of download

Example) Parameter file No. 70 of the media is downloaded to the condensation custom pattern at the sewing end No. 10.

1) Open the media cover and insert the compact flash (TM) (Optional Part No. : 40000100) from the insertion opening.

* Panel function does not work with the cover opened.

2) Selection of data

Press ❶ in the communication setting screen to display the data selection screen. Data form which is selected at present is shown in reverse video.

■ Data selection screen

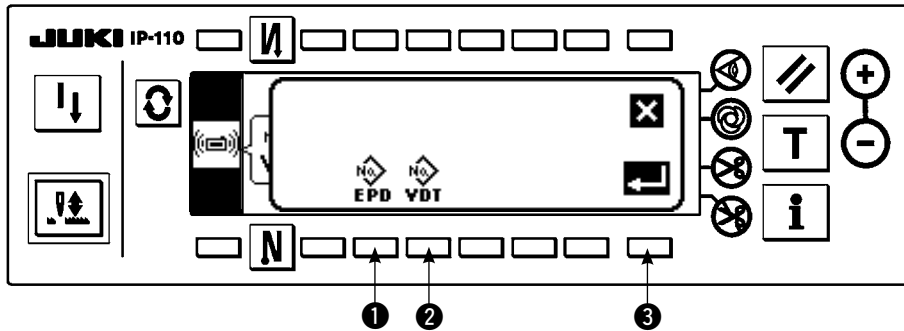

[Explanation of the pictograph]

 : Parameter data

 : Vector form data

Press ❶ and determine with ❸ after selecting the parameter.

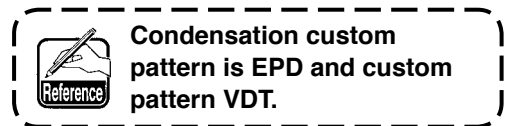

3) Selection of communication method

Press ❷ in the communication setting screen to display the communication method setting screen.

■ Communication setting screen

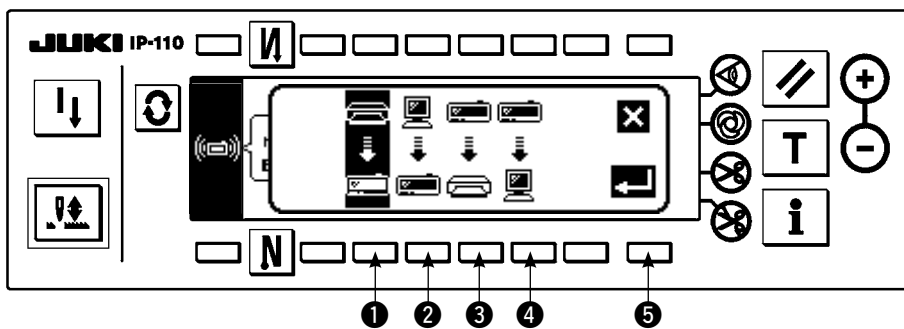

Communication method which is selected at present is shown in reverse video.

[Explanation of the pictograph]

❶  : Down load from the media

❷  : Download from SU-1

❸  : Upload to the media

❹  : Upload to SU-1

Press ❶ to select download from the media. Then press ❺ to determine.

4) Selection of file No. of the media

Press ③ in the communication setting screen to display the file No. input screen (10-key screen) of compact flash.

■ File No. input screen (10-key screen)

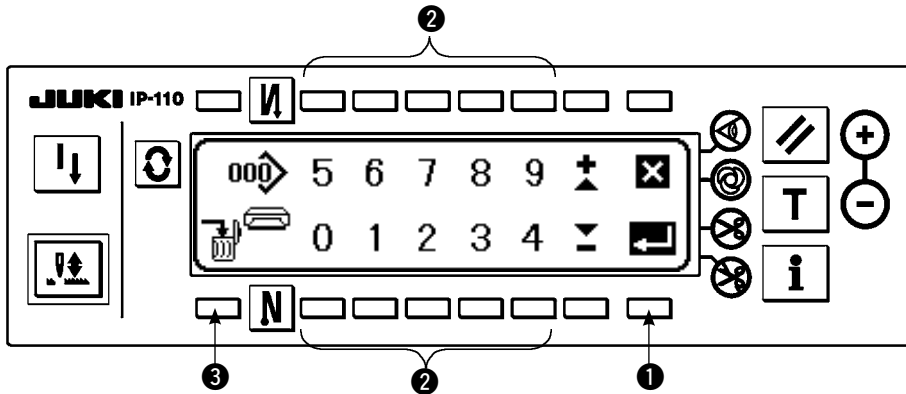

Input the file No. of compact flash with ②. The file No. which has been inputted is displayed in >. The No. is determined with ① after inputting the file No.

 **Input section ② as 070 and determine with ① in the file input screen (10-key screen) since the file No. of the example is 070.**

5) Custom pattern No. setting

Press ① and ② in the communication setting screen (download) to change the custom pattern No.

■ Communication setting screen (download)

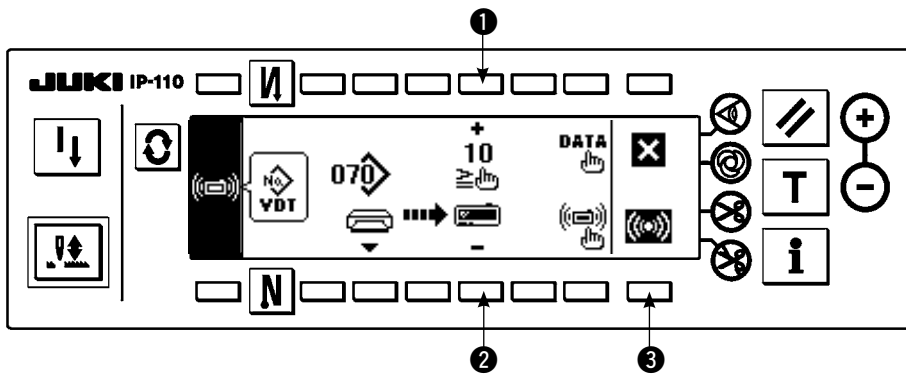

6) Start of download
When all settings have been completed, press ③ in the communication setting screen (download) to start the download.

■ During communication screen

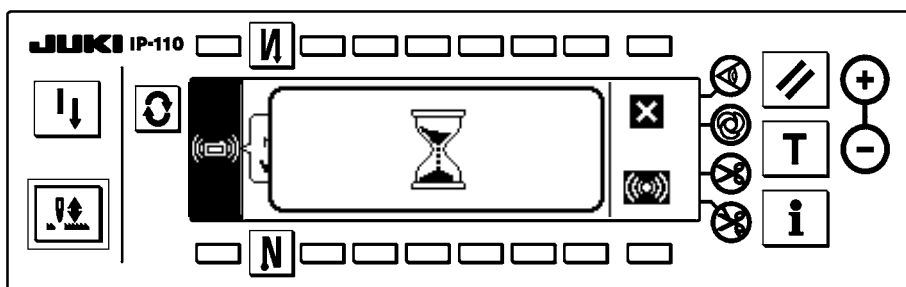

When the screen returns to the communication setting screen after display of the during communication screen, communication is completed.

Example of upload

Example) Custom pattern No. 8 is uploaded as the vector form file No. 15 of the media.

1) Open the media cover and insert the Compactflash(TM) (Optional Part No. : 40000100) from the insertion opening.
* Panel function does not work with the cover opened.

2) Selection of data

Press ① in the communication setting screen to display the data selection screen.

[Explanation of the pictograph]

EPD : Parameter data

VDT : Vector form data

Press ② and determine with ③ after selecting the vector form data.

 **Condensation custom pattern is EPD and custom pattern VDT.**

3) Selection of communication method

Press ② in the communication setting screen to display the communication method setting screen.

[Explanation of the pictograph]

- ① : Down load from the media
- ② : Download from SU-1
- ③ : Upload to the media
- ④ : Upload to SU-1

Press ③ to select the upload to the media. Then press ⑤ to determine.

4) Setting of the custom pattern No.

Press ④ and ⑤ in the communication setting screen to set the custom pattern No.

5) Selection of the file No. of the media

Press ③ in the communication setting screen to display the file No. of the media input screen.

Input the file No. of the media. The inputted file No. is displayed in . After inputting the file No., determine it with ①.

6) Start of the upload

When all setting procedures have been completed, press ⑥ in the communication setting screen to start uploading.

When the screen returns to the communication setting screen after display of the during communication screen, communication is completed.

■ Communication setting screen (upload)

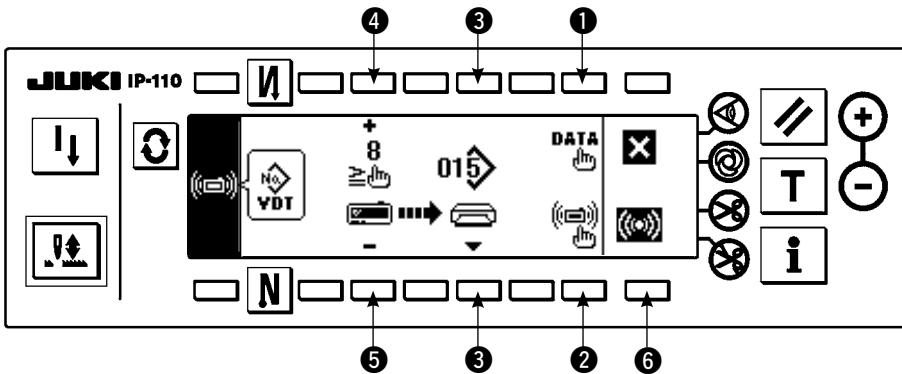

[How to delete the file of the media]

Press switch ③ after selecting the No. you desire to delete in the file No. of the media input screen (refer to p. 76), and the screen moves to the deletion confirmation screen.

■ Deletion confirmation screen

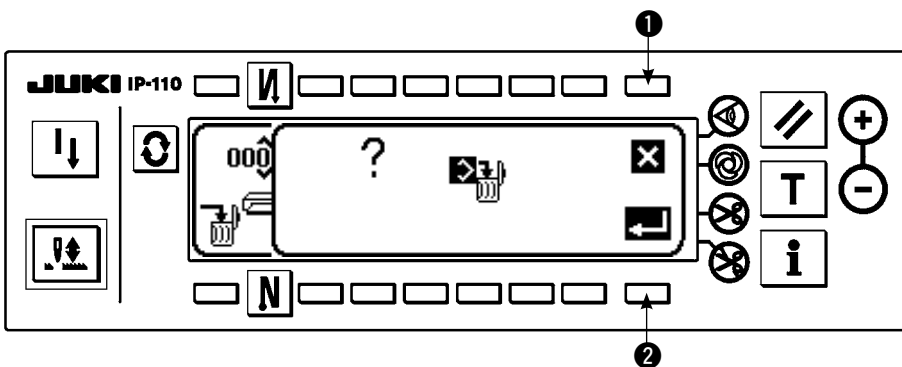

Press ① and the deletion is discontinued. Then the screen returns to the file No. input screen. Press ② and the deletion is executed. Then the screen returns to the file No. input screen.



The deleted file is not restored. Be very careful when executing the deletion.

6-17. Setting for functions

(1) How to change over to the function setting mode



Do not perform switch operations other than those described in the following explanations.

Be sure to re-turn the power switch ON after one second or more has passed. If the power is turned ON immediately after turning it OFF, the sewing machine may not work normally. In this case, turn ON the power again.



WARNING :

To avoid possible personal injuries caused by movement other than that you desired, do not operate the switches in the procedure other than those required, as described below, to specify the functions.

There are two kinds of function settings, Level 1 and Level 2.

Level 1 : Change of setting can be performed without turning OFF the power switch.

Level 2 : It is necessary to turn OFF the power switch after change of setting.

For the details of setting No., see p113.

[Setting procedure of Level 2]

- 1) Turn ON the power. When the needle bar is not in its UP position, turn the handwheel to bring the needle bar to its UP position.

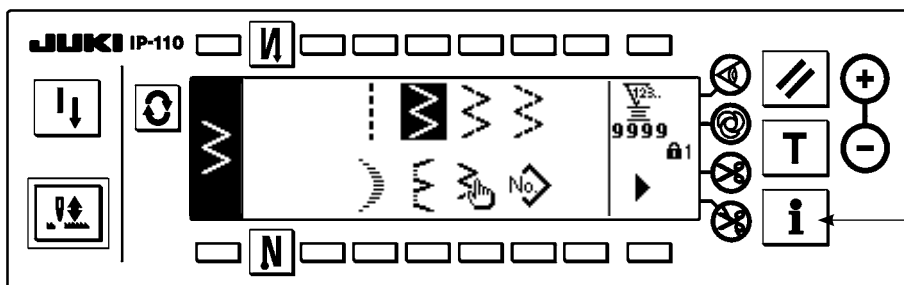

- 2) Press switch ① for approximately three seconds.

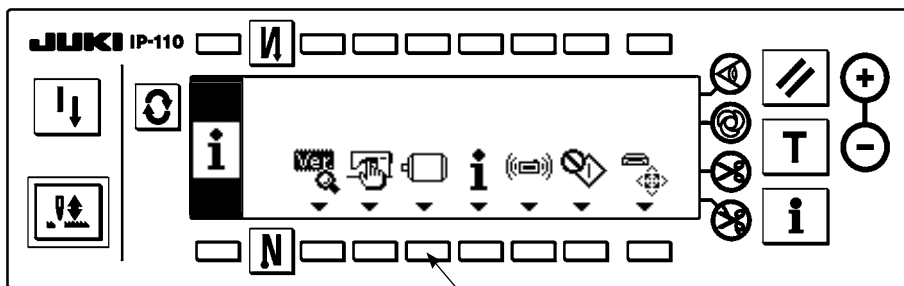

- 3) Press switch ② for approximately three seconds.

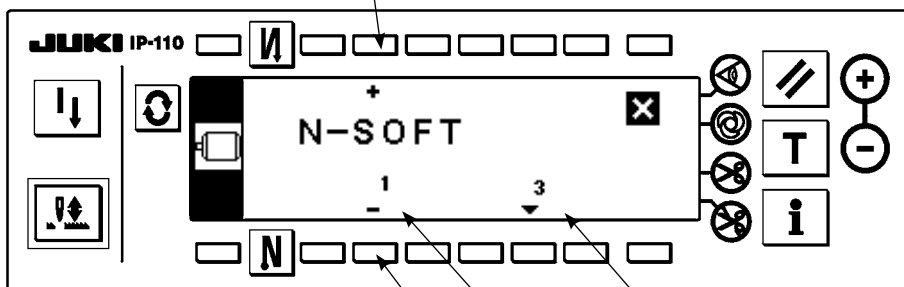

- 4) This screen is the function setting screen. Change the setting No. with "+/-" Key of switch ③. For the details of setting No., see P 113.

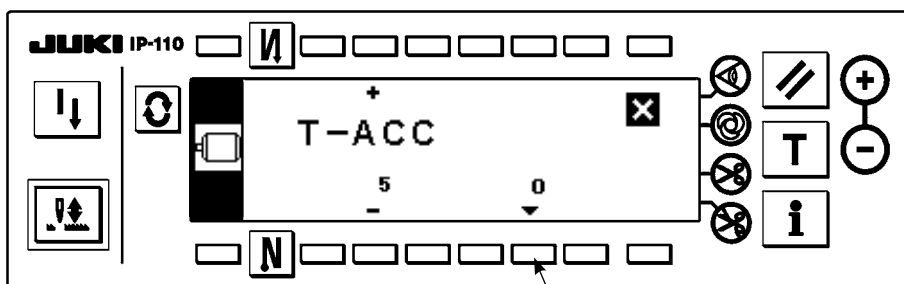

- Example) Changing the flicker reducing function (Setting No. 5)
Change the setting No. to "5" with "+" Key of switch ③ in the figure above.
· Press switch ④.

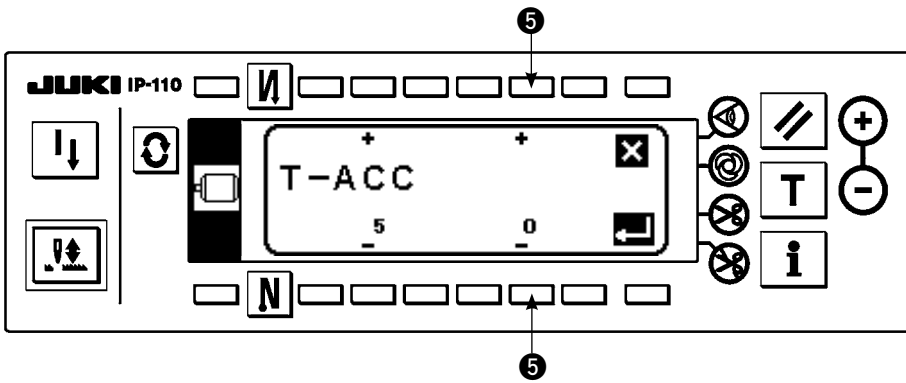

- Change set value with “+/-” Key of switch **5**.

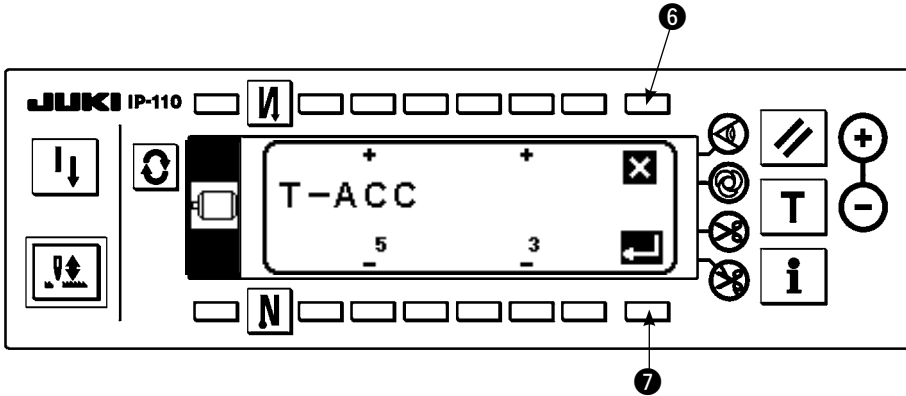

The set value has been changed from “0” to “3”.

- When this changed value is acceptable, press switch **7**.
When you desire to return the value to the previous one, press switch **6**.

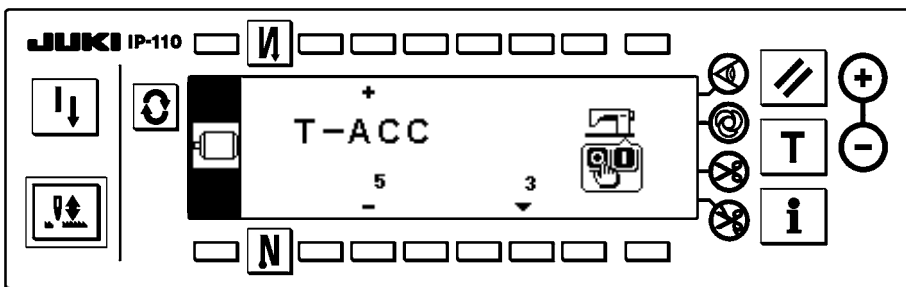

- Turn OFF the power switch and turn ON the power switch after approximately one second.
- Change of the set value is determined by turning OFF the power switch.

[Setting procedure of Level 1]

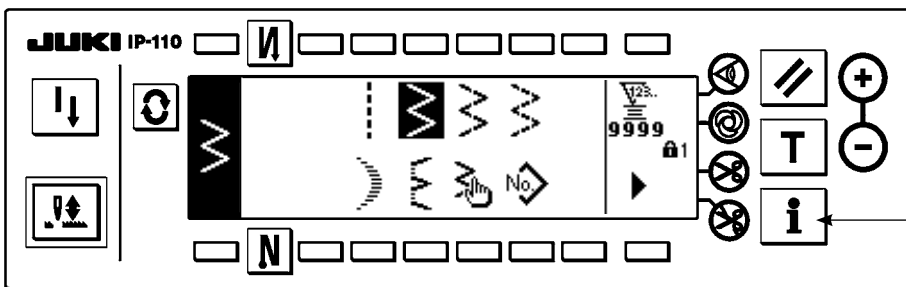

- 1) Press switch **1** for approximately three seconds.

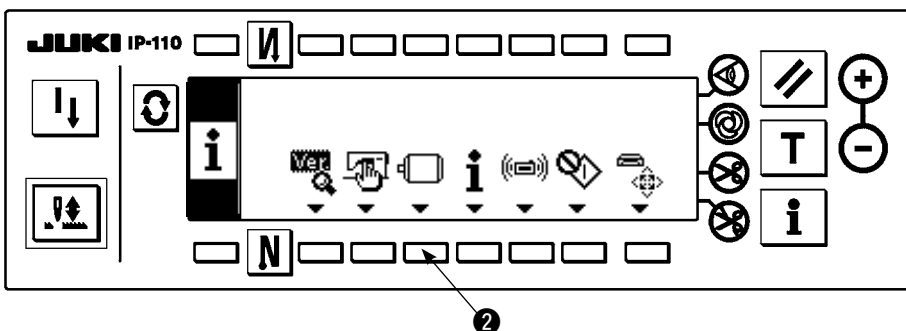

- 2) Press switch **2**.

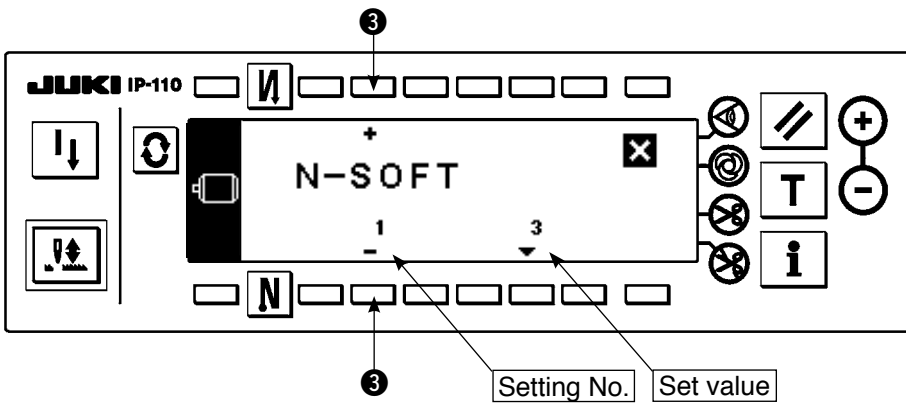

3) This screen is the function setting screen.
 Change the setting No. with “+/-” Key of switch ③.

For the details of setting No., see page 113.

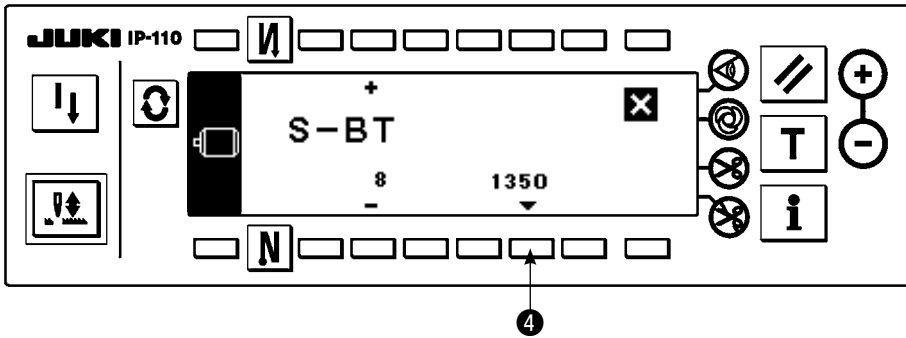

Example) Changing the number of rotation of reverse feed stitching (Setting No. 8)

Change the setting No. to “8” with “+” Key of switch ③ in the figure above.

· Press switch ④.

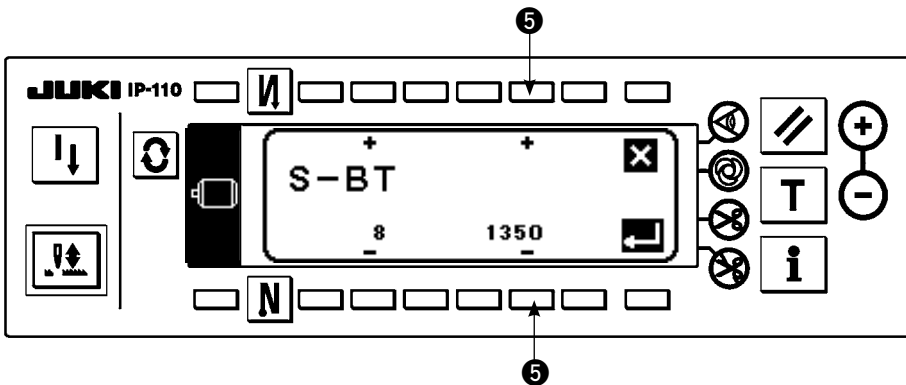

· Change the set value with “+/-” Key of switch ⑤.

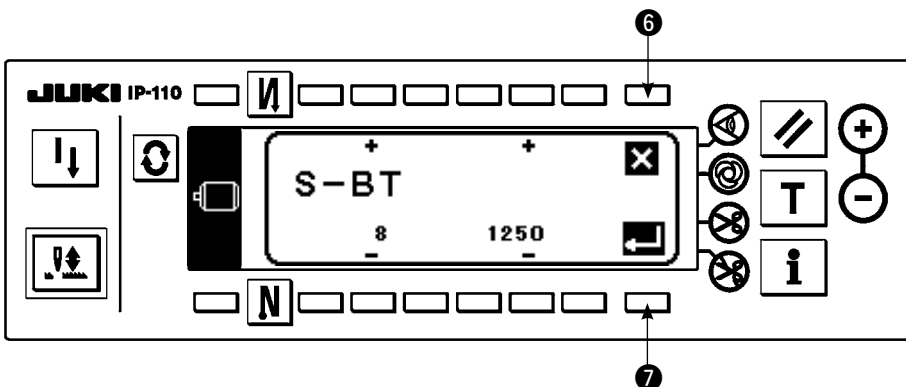

· Set value has been changed from 1350 to 1250.

· When this changed value is acceptable, press switch ⑦.

Press switch ⑥ when you desire to return the value to the former one.

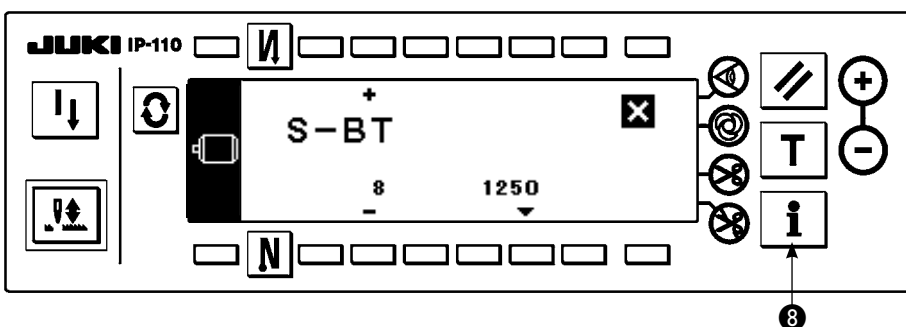

· Press switch ⑧ in case of sewing.

(2) Function setting list

No.	Item	Description	Setting level	Setting range	Panel display Standard set value	Ref. Page
1	Soft start function	The number of stitches to be sewn at a low speed when the soft-start function is used at the start of sewing. 0 : Soft-start function is not operative	1	0 to 9	N-SOFT 3	117
5	Flicker reducing function	Flicker reducing function (If the hand lamp flickers.) 0 : Flicker reducing function is not operative 1 : Less effective if 8 : Highly effective	2	0 to 8	T-ACC 0	117
* 7	Unit of bobbin thread counting down	Unit of bobbin thread counting down 0 : Count/10 stitches 1 : Count/15 stitches 2 : Count/20 stitches	1	0/1/2	RATIO 0	
* 8	Number of rotation of reverse feed stitching	Sewing speed of reverse feed stitching	1	150 to 3000	S-BT 1350	
10	Setting of needle bar stop position when the sewing machine stops.	Position of needle bar is specified when the sewing machine stops. 0 : Predetermined lowest position 1 : Predetermined highest position	2	1/0	NPS 0	117
11	Click sound of panel switch	Click sound of panel switch is specified. 0 : Without click 1 : With click	2	1/0	SOUND 1	117
12	Optional switch function selection	Switching of functions of optional switch 0 : No function 1 : Needle up/down compensating stitching 2 : No function 3 : No function 4 : Thread trimming function 5 : Presser foot lifting function 6 : One stitch compensating stitching 7 : No function 8 : Pedal neutral presser lifting function selection Do not set to 2, 3 and 7. If these numbers are set, trouble or accident will be caused.	2	0 to 8	SW2 0	118
* 13	Function of prohibiting start of the sewing machine by bobbin thread counter	Function of prohibiting start of the sewing machine by bobbin thread counter (After thread trimming) 0 : When counting is out (-1 or less), function of prohibiting start of the sewing is not operative. 1 : When counting is out (-1 or less), function of prohibiting start of the sewing machine is operative. 2 : Function of "1" + counter (-1 or less) stop (temporary stop)	2	0/1/2	ASCNT 0	
18	Bird's nest prevention function	Effective in combination with machine head with bird's nest prevention function 0 : Without bird's nest prevention function 1 : With bird's nest prevention function 2 : With bird's nest prevention function with needle thread release after clamp function	2	0/1/2	BNC 0	
19	Needle thread release at sewing start function	Effective in combination with machine head with bird's nest prevention function 0 : Without needle thread release function 1 : With needle thread release function	2	1/0	THOLD 0	
21	Function of neutral presser lifting	Function of lifting presser foot when the pedal is in neutral position. 0 : Function of neutral automatic presser lifting is not operative. 1 : Selection of function of neutral presser lifting.	2	1/0	N-NPL 0	118
22	Function of changeover of compensating switch on the operation panel function	Function of needle up/down compensating switch on the operation panel can be changed. 0 : Needle up/down compensation 1 : One stitch compensation	2	1/0	F-CMSP 0	118
23	Presser lifting function selection	Presser lifting function selection 0 : Ineffective 1 : Effective	2	1/0	F-AFL 0	
* 24	Function of fine adjustment of number of rotation	Number of rotation can be compensated. Be sure to normally use this function with "0".	2	±15	F-FAS 0	
28	Number of stitches of bird's nest needle thread release	Effective in combination with machine head with bird's nest prevention function Number of stitches from start of sewing to release of needle thread can be set.	1	0 to 30	F-UTHR 1	

* Do not change the set values with asterisk (*) mark as they are functions for maintenance. If the standard set value set at the time of delivery is changed, it is in danger of causing the machine to be broken or the performance to be deteriorated. If it is necessary to change the set value, please purchase the Engineer's Manual and follow the instructions. (Descriptions of setting in this list are the standard values at the time of delivery of LZ-2290A.) However, contents of function setting are subject to change for improvement of function and performance without notice.

No.	Item	Description	Setting level	Setting range	Panel display Standard set value	Ref. Page
30	Function of reverse feed stitching on the way	Function of reverse feed stitching on the way 0 : Function of reverse stitching on the way is not operative. 1 : Function of reverse feed stitching on the way is operative.	2	1/0	OBT 0	119
31	Number of stitches of reverse feed stitching on the way	Number of stitches of reverse feed stitching on the way.	2	0 to 19	N-OBT 4	119
32	Effective condition of reverse feed stitching on the way when the sewing machine is stopping.	Effective condition of reverse feed stitching on the way 0 : Function is not operative when the sewing machine stops. 1 : Function is operative when the sewing machine stops.	2	1/0	OBTS 0	119
* 33	Thread trimming function by reverse feed stitching on the way	Thread trimming function by reverse feed stitching on the way 0 : Automatic thread trimming function after completion of reverse feed stitching on the way is not operative. 1 : Automatic thread trimming after completion of reverse feed stitching on the way is performed.	2	1/0	OBTT 0	119
* 35	Number of rotation at a low speed	Lowest speed by pedal	1	20 to 400	S-POS 200	
36	Number of rotation of thread trimming	Thread trimming speed	2	20 to 250	S-TRM 180	
37	Number of rotation of soft-start	Sewing speed at the start of sewing (soft-start)	1	150 to 5500	S-SOFT 1200	
38	One-shot speed	Setting of number of revolution at the time of one-shot automatic sewing	1	200 to 5500	S-ASS 2000	
* 39	Pedal stroke at the start of rotation	Position where the sewing machine starts rotating from pedal neutral position (Pedal stroke)	2	10 to 50	P-SSP 30	
* 40	Low speed section of pedal	Position where the sewing machine starts accelerating from pedal neutral position (Pedal stroke)	2	10 to 100	P-LSA 60	
* 41	Starting position of lifting presser foot by pedal	Position where the cloth presser starts lifting from pedal neutral position (Pedal stroke)	2	-60 to -10	P-FLW -21	
* 42	Starting position of lowering presser foot	Starting position of lowering presser foot Stroke from the neutral position	2	8 to 50	P-FLD 10	
* 43	Pedal stroke 2 for starting thread trimming	Position 2 where the thread trimming starts from pedal neutral position (When the function of lifting presser foot by pedal is provided.) (Pedal stroke)	2	-60 to -110	P-TRM2 -51	
* 44	Pedal stroke for reaching the maximum number of rotation	Position where the sewing machine reaches its highest sewing speed from pedal neutral position (Pedal stroke)	2	10 to 150	P-MAX 150	
* 45	Compensation of neutral point of the pedal	Compensation value of the pedal sensor	2	-15 to 15	P-ANP 0	
* 46	Auto-lifter selecting function	Auto-lifter selection 0 : Solenoid drive system 1 : Pneumatic drive system	2	1/0	FLSEL 0	120
* 47	Holding time of lifting auto-lifter	Limitation time of waiting for lifting solenoid type auto-lifter device	2	10 to 600	T-FL 60	120
* 48	Pedal stroke 1 for starting thread trimming	Position where thread trimming starts from pedal neutral position (Standard pedal) (Pedal stroke)	2	-60 to -10	P-TRM1 -51	
* 49	Lowering time of presser foot	Lowering time of presser foot after the pedal has been depressed. (Start of rotation of the sewing machine is delayed during this time.)	2	0 to 250	T-FLWT 140	121

* Do not change the set values with asterisk (*) mark as they are functions for maintenance. If the standard set value set at the time of delivery is changed, it is in danger of causing the machine to be broken or the performance to be deteriorated. If it is necessary to change the set value, please purchase the Engineer's Manual and follow the instructions. (Descriptions of setting in this list are the standard values at the time of delivery of LZ-2290A.) However, contents of function setting are subject to change for improvement of function and performance without notice.

No.	Item	Description	Setting level	Setting range	Panel display Standard set value	Ref. Page
55	Foot lift after thread trimming	Function of lifting presser foot at the time of (after) thread trimming 0 : Not provided with the function of lifting presser foot after thread trimming 1 : Provided with the function of lifting presser foot automatically after thread trimming	2	1/0	FLAT 1	120
56	Reverse revolution to lift the needle after thread trimming	Function of reverse revolution to lift the needle at the time of (after) thread trimming 0 : Not provided with the function of reverse revolution to lift the needle after thread trimming 1 : Provided with the function of reverse revolution to lift the needle after thread trimming	2	1/0	RATRM 0	120
58	Function of holding predetermined upper/lower position of the needle bar	Function of holding predetermined upper/lower position of the needle bar 0 : Not provided with the function of holding predetermined upper/lower position of the needle bar 1 : Provided with the function of holding predetermined upper/lower position of the needle bar	2	1/0	HPOS 0	120
59	Function of Auto/Manual change-over of reverse feed stitching at the start of sewing	This function can specify the sewing speed of reverse feed stitching at the start of sewing. 0 : The speed will depend on the manual operation by pedal, etc. 1 : The speed will depend on the specified reverse feed stitching speed (No. 8).	2	1/0	SBTO 1	120
60	Function of stop immediately after reverse feed stitching at the start of sewing	Function at the time of completion of reverse feed stitching at the start of sewing 0 : Not provided with the function of temporary stop of the sewing machine at the time of completion of reverse feed stitching at the start of sewing 1 : Provided with the function of temporary stop of the sewing machine at the time of completion of reverse feed stitching at the start of sewing.	2	1/0	SBTQ 0	121
* 64	Change-over speed of condensation stitch or EBT (end back tack)	Initial speed when starting EBT	2	0 to 250	S-WAIT 170	
67	Presser lifting solenoid output duty setting	Presser lifting solenoid output duty (%)	2	5 to 40	FLDTY 20	
70	Function of soft-down of presser foot	Presser foot is slowly lowered. 0 : Presser foot is rapidly lowered. 1 : Presser foot is slowly lowered.	2	0/1	F-SDFL 0	121
71	Function of limitation of re-acceleration from reduction of speed	Speed limitation is performed at the time of re-acceleration on the way of reducing speed of the sewing machine. It is effective when operating inching sewing.	2	0 to 5	F-ACRA 0	121
72	Function of limitation of acceleration at the start of rotation	Speed limitation is performed at the time of start-up of the sewing machine (excluding the start of sewing). It is effective when operating inching sewing.	1	0 to 5	F-ACR 1	121
73	Retry function	This function is used when needle cannot pierce materials . 0 : Normal 1 : Retry function is provided.	1	1/0	F-RET 1	122
76	Function to select the start-up speed of the sewing machine	Starting curve of the sewing machine is selected. 0 : Normal curve 1 : More sharp curve	2	1/0	F-SCS 0	122
84	Presser lifting solenoid initial motion suction time	Suction motion time of presser lifting solenoid (msec)	2	40 to 300	T-PUT 100	
87	Function of pedal curve selection	Pedal curve is selected. (Improving pedal inching operation) <div style="text-align: center;"> <p>Number of rotations</p> <p>Pedal stroke</p> </div>	2	0/1/2	F-PCS 0	122

* Do not change the set values with asterisk (*) mark as they are functions for maintenance. If the standard set value set at the time of delivery is changed, it is in danger of causing the machine to be broken or the performance to be deteriorated. If it is necessary to change the set value, please purchase the Engineer's Manual and follow the instructions. (Descriptions of setting in this list are the standard values at the time of delivery of LZ-2290A.)
However, contents of function setting are subject to change for improvement of function and performance without notice.

No.	Item	Description	Setting level	Setting range	Panel display Standard set value	Ref. Page
89	Return of needle thread feed	Return of feed function 0 : Without function 1 : With function	2	1/0	TRS 1	
* 91	Function of prohibiting compensation operation after turning handwheel by hand	Function of compensating stitching when turning handwheel by hand at the time of completion of constant-dimension stitching 0 : Function of compensating stitching is effective. 1 : Function of compensating stitching is prohibited.	2	1/0	F-PMAT 1	
92	Function of reducing speed of reverse feed stitching at the start of sewing	Function to reduce speed at the time of reverse feed stitching at the start of sewing. 0 : Speed is not reduced. 1 : Speed is reduced.	2	1/0	F-DSBT 0	121
93	Function added to needle up/down compensating switch	Operation of needle up/down compensating switch is changed after turning ON the power or thread trimming. 0 : Normal (needle up/down compensating stitching only) 1 : One stitch compensating stitching is performed only when aforementioned changeover is made. (Upper stop → upper stop)	2	1/0	F-MADF 0	122
96	Max. number of rotation setting	Max. number of rotation of the sewing machine head can be set. * Setting varies in accordance with resistance pack to be connected.	2	50 to MAX	S-MAX 4000	122
100	Thread release at sewing start function	Thread release at sewing start function Setting of number of stitches to actuate thread release function at the start of sewing	2	0 to 9	F-THLS 0	
101	Counter function selection	Counter function selection Whether counter operates every thread trimming or manually is selected. 0 : Every thread trimming 1 : By manual SW	2	1/0	F-MAC 0	
103	Pedal sensor neutral compensation function	Pedal sensor neutral compensation function 0 : Pedal sensor neutral compensation function is ineffective. 1 : Pedal sensor neutral compensation function is effective.	2	1/0	F-ANP 0	

* Do not change the set values with asterisk (*) mark as they are functions for maintenance. If the standard set value set at the time of delivery is changed, it is in danger of causing the machine to be broken or the performance to be deteriorated. If it is necessary to change the set value, please purchase the Engineer's Manual and follow the instructions. (Descriptions of setting in this list are the standard values at the time of delivery of LZ-2290A.)
However, contents of function setting are subject to change for improvement of function and performance without notice.

(3) Detailed explanation of selection of functions

① Selection of the soft-start function (Function setting No.1 N-SOFT)

The needle thread may fail to interlace with the bobbin thread at the start of sewing when the stitching pitch (stitch length) is small or a thick needle is used. To solve such problem, this function (called "soft-start") is used to limit the sewing speed, thereby assuring successful formation of the starting stitches.

0 : The function is not selected.

1 to 9 : The number of stitches to be sewn under the soft-start mode.

The sewing speed limited by the soft-start function can be changed. (Function setting No.37 S-SOFT)

Data setting range

150 to 5,500 sti/min <50 sti/min>

② Flicker reducing function (Function setting No.5 T-ACC)

The function reduces flickering of the hand lamp at the start of sewing. The higher the set value increases, the more effective the function will work.

Setting range

0 to 8

0 : Flicker reducing function does not work.

to

8 : Flickering is effectively reduced.



The more effective the flicker reducing function works (the more the set value is made), the lower the start-up speed of the sewing machine will become.

③ Setting of the needle bar stop position when the sewing machine stops (Function setting No.10 NPS)

The position of the needle bar when the pedal is in its neutral position is specified.

0 : Down The needle bar stops in the lowest position of its stroke.

1 : Up The needle bar stops in the highest position of its stroke.



If the stop position of the needle bar is set to the highest position, the thread trimming action will be taken after the needle bar comes down once to the lowest position.

④ Sound of click of the key switch mounted on the PSC box (Function setting No.11 SOUND)

This function selects whether the sound is effective or ineffective when operating the four key switches mounted on the PSC box.

0 : off The sound of click is ineffective.

1 : on The sound of click is effective.

- ⑤ **Optional switch function selection (Function setting No.12 SW 2) :** It is used only when it is combined with the machine head provided with the optional switch. (Optional SW kit Part No. : 40003640)

Insert the cord connector pins into No. 7 and No. 8 of 12P connector (CN53).

A. In case of the machine with the auxiliary thread take-up lever

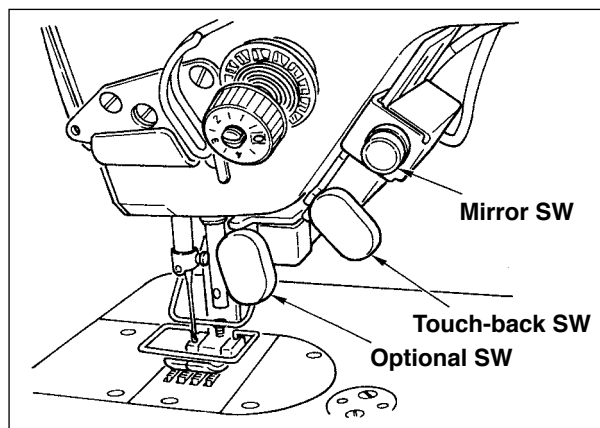

B. In case of the machine without the auxiliary thread take-up lever

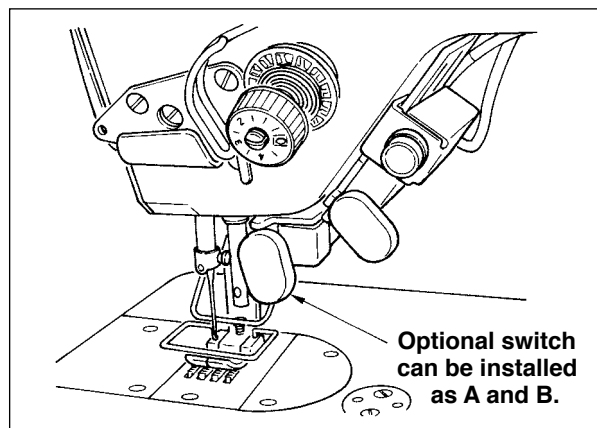

Functions to be assigned to the optional switch can be selected from the following functions.

- 0 : No function (Standard setting)
 - 1 : Needle up / down compensating stitching : Every time the switch is pressed, normal feed stitching by half stitch is performed. (Same operation as that of up/down compensating stitching switch on the panel.)
 - 2 : No function
 - 3 : No function
 - 4 : Thread trimming function : This function is actuated as the thread trimming switch.
 - 5 : Presser foot lifting function : This function is actuated as the foot lifter switch.
 - 6 : One stitch compensating stitch : Every time the switch is pressed, one stitch stitching operation is executed.
 - 7 : No function
 - 8 : Pedal neutral presser lifting function selection
- Do not set to 2, 3, and 7. If these numbers are set, trouble or accident will be caused.

- ⑥ **Neutral automatic presser lifting function (with AK device only) (Function setting No.21 N-NPL)**

This function can automatically lift the presser foot when the pedal is in the neutral position. Automatic lifting time of the pedal depends on the automatic lifting time after thread trimming and when the presser foot is automatically lowered, it is automatically lifted at the second neutral position after it has come off the neutral position once.

- 0 : off Function of neutral automatic presser lifting is not operative.
- 1 : on Selection of function of neutral automatic presser lifting

- ⑦ **Function of changeover of needle up/down compensating switch on the operation panel function (Function setting No. 22 F-CMSP)**

Function of needle up/down compensating switch on the panel of IP-110 can be changed over to needle up/down compensating stitching or one stitch compensating stitching.

- 0 : Needle up/down compensating stitching
- 1 : One stitch compensating stitching

⑧ **Function of reverse feed stitching on the way (Function setting Nos. 30 to 33 OBT, OBTS, OBTT)**

Functions of the limit of number of stitches and thread trimming command can be added to the touch back switch on the sewing machine head.

Function setting No. 30 Function of reverse feed stitching on the way is selected.

- 0 : off Normal back-tack function
- 1 : on Function of reverse feed stitching on the way

Function setting No. 31 Number of stitches performing reverse feed stitching on the way is set.

0 to 19 stitches <1 / stitch>

Function setting No. 32 Effective condition of reverse feed stitching on the way

- 0 : off Inoperative when the sewing machine stops.
(Reverse feed stitching on the way functions only when the sewing machine is running.)
- 1 : on Operative when the sewing machine stops.
(Reverse feed stitching on the way functions both when the sewing machine is running and stops.)

Either condition is operative when the sewing machine is running.

Function setting No. 33 Thread trimming is performed when reverse feed stitching on the way is completed.

- 0 : off Without thread trimming
- 1 : on Thread trimming is executed.

Actions under each setting state

Application	Function setting			Output function
	No.30	No.32	No.33	
①	0	0 or 1	0 or 1	It works as normal touch-back switch.
②	1	0	0	When operating touch-back switch at the time of depressing front part of the pedal, reverse feed stitching as many as the number of stitches specified by the function setting No. 31 can be performed.
③	1	1	0	When operating touch-back switch at the time of either stop of the sewing machine or depressing front part of the pedal, reverse feed stitching as many as the number of stitches specified by the function setting No. 31 can be performed.
④	1	0	1	When operating touch-back switch at the time of depressing front part of the pedal, automatic thread trimming is performed after reverse feed stitching as many as the number of stitches specified by the function setting No. 31 has been performed.
⑤	1	1	1	When operating touch-back switch at the time of either stop of the sewing machine or depressing front part of the pedal, automatic thread trimming is performed after reverse feed stitching as many as the number of stitches specified by the function setting No. 31 has been performed.

- ① Used as the normal reverse feed stitching touch-back switch.
- ② Used for reinforcing seam (lapped seam) during sewing. (It works only when the sewing machine is running.)
- ③ Used for reinforcing seam (lapped seam) during sewing. (It works either when the sewing machine stops or when the sewing machine is running.)
- ④ Used as starting switch for reverse feed stitching at the sewing end. (Used as the substitute for thread trimming by depressing back part of the pedal. It works only when the sewing machine is running. It is especially effective when the sewing machine is used as the standing-work machine.)
- ⑤ Used as starting switch for reverse feed stitching at the sewing end. (Used as the substitute for thread trimming by depressing back part of the pedal. It works either when the sewing machine stops or when the sewing machine is running. It is especially effective when the sewing machine is used as the standing-work machine.)

⑨ **Holding time of lifting presser foot (Function setting No.47 T-FL)**

Solenoid type presser foot lifter (No. 46 0) can adjust the holding time control of lifting presser foot.

This function automatically lowers the presser foot when the time set with the setting No. 47 has passed after lifting the presser foot.

When the pneumatic type presser foot lifter (No. 46 1) is selected, the holding time control of lifting presser foot is limitless regardless of the set value.

Setting range

10 to 600 sec <10 / sec>

⑩ **Foot lift function after thread trimming (Function setting No.55 FLAT)**

This function can automatically lift the presser foot after thread trimming. This function is effective only when it is used in combination with the AK device.

0 : off Function of automatically lifting the presser foot is not provided.
(Presser foot does not automatically go up after thread trimming.)

1 : on Function of automatically lifting the presser foot is provided.
(Presser foot automatically goes up after thread trimming.)

⑪ **Reverse revolution to lift the needle after thread trimming (Function setting No.56 RATRM)**

This function is used to make the sewing machine rotate in the reverse direction after thread trimming to lift the needle bar almost to highest position. Use this function when the needle appears under the presser foot and it is likely to make scratches on the sewing products of heavy-weight material or the like.

0 : off Function of making the sewing machine rotate in the reverse direction to lift the needle after thread trimming is not provided.

1 : on Function of making the sewing machine rotate in the reverse direction to lift the needle after thread trimming is provided.



The needle bar is raised, by rotating the machine in the reverse direction, almost to the highest dead point. This may result in slip-off of the needle thread. It is therefore necessary to adjust the length of thread remaining after thread trimming properly.



When the function of reverse revolution to lift the needle after thread trimming is set, the needle bar is out of the UP position after thread trimming. It is necessary to turn the handwheel by hand when turning ON the power next time. It is not possible to enter the edit screen at the time of reverse revolution to lift the needle after thread trimming. It is necessary to adjust the position to UP position by turning the handwheel by hand before entering the edit screen.

⑫ **Function of holding predetermined upper / lower position of the needle bar (Function setting No.58 HPOS)**

When the needle bar is in the upper position or in the lower position, this function holds the needle bar by applying a brake slightly.

0 : off Function of holding predetermined upper/lower position of the needle bar is ineffective.

1 : on Function of holding predetermined upper/lower position of the needle bar is effective.

⑬ **Change-over function of AUTO/Pedal for sewing speed of the reverse feed stitching at the start of sewing (Function setting No.59 SBTO)**

This function selects whether the reverse feed stitching at the start of sewing is performed without a break at the speed set by the function setting No. 8 or the stitching is performed at the speed by the pedal operation.

0 : Manu The speed is indicated by the pedal operation.

1 : Auto Automatic stitching at the specified speed



- 1. The max. sewing speed of the reverse feed stitching at the start of sewing is limited to the speed set by the function setting No. 8 regardless of the pedal.**
- 2. When "0" is selected, stitches of reverse feed stitching may not match those of normal feed stitching.**

⑭ **Function of stop immediately after the reverse feed stitching at the start of sewing (Function setting No.60 SBTQ)**

This function temporarily stops the sewing machine even when keeping depressing the front part of the pedal at the time of completion of process of reverse feed stitching at the start of sewing. It is used when sewing a short length by reverse feed stitching at the start of sewing.

- 0 : Not provided with the function of temporary stop of the sewing machine immediately after the reverse feed stitching at the start of sewing
- 1 : Provided with the function of temporary stop of the sewing machine immediately after the reverse feed stitching at the start of sewing

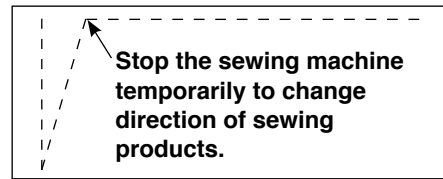

⑮ **Function of soft-down of presser foot (with AK device only) (Function setting Nos.70 and 49 F-SDFL, T-FLWT)**

This function can softly lower the presser foot.

This function can be used when it is necessary to decrease contact noise, cloth defect, or slippage of cloth at the time of lowering the presser foot.

Caution Change the time of function setting No. 49 together at the time of selecting the function of soft-down since the sufficient effect cannot be obtained unless the time of function setting No. 49 is set longer when lowering the presser foot by depressing the pedal.

0 to 250 ms
10 ms/Step

- 0 : Function of soft-down of presser foot is not operative. (Presserfoot is rapidly lowered.)
- 1 : Selection of function of soft-down of presser foot

⑯ **Function of improving inching operation (Function setting Nos.71 and 72 F-ACRA, F-ACR)**

This function improves operability of one-stitch sewing by operating the high-speed switch for the pedal or sewing machine for standing work.

The more the set value becomes, the more the speed limitation at the start of rotation is remarkably added and operability of one-stitch sewing is improved.

Function setting No. 71 limits the speed at the time of re-acceleration on the way of reducing speed.
Function setting No. 72 limits acceleration from the stop state.

Caution This function fails to work when turning ON the power or starting sewing immediately after thread trimming.

0 to 5
1/Step

0 to 5
1/Step

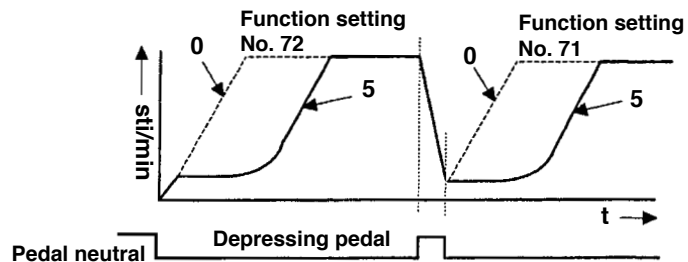

⑰ **Function of reducing speed of reverse feed stitching at the start of sewing (Function setting No.92 F-DSBT)**

Function to reduce speed at the time of reverse feed stitching at the start of sewing. : Normal use depending on the pedal condition (Speed is accerated to the highest without a break.)

This function is used when temporary stop is used properly. (Cuff and cuff attaching)

- 0 : Speed is not reduced.
- 1 : Speed is reduced.

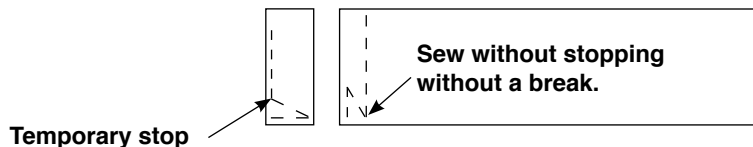

⑱ **Retry function (Function setting No.73 F-RET)**

When the retry function is used, if the sewing material is thick and not pierced with needle, this function makes the needle pierce in the material with ease.

- 0 : Normal
- 1 : Retry function is provided.

⑲ **Function to select the start-up speed of the sewing machine (Function setting No.76 F-SCS)**

This function is selected in the case where the speed of the sewing machine is desired to be more at the time of start-up. (Time required to start is shortened by approximately 10%.)

- 0 : Normal curve
- 1 : More sharp curve



If "1" is set, motor may move irregularly. In addition, noise may occur when the sewing machine is running or noise may increase when the sewing machine is running.

⑳ **Function of pedal curve selection (Function setting No.87 F-PCS)**

This function can perform the selection of the curve of number of rotation of the sewing machine against the depressing amount of the pedal.

Change to this function when you feel that inching operation is hard or that pedal response is slow.

- 0 : Number of rotation of the sewing machine in terms of the depressing amount of the pedal increases linearly.
- 1 : Reaction to intermediate speed in terms of the depressing amount of the pedal is delayed.
- 2 : Reaction to intermediate speed in terms of the depressing amount of the pedal is advanced.

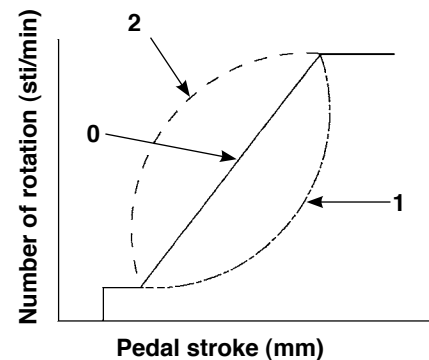

㉑ **Function added to the needle up / down compensating switch (Function setting No.93 F-MADF)**

One stitch operation can be performed only when the needle up / down compensating switch is pressed at the time of upper stop immediately after turning ON the power switch or upper stop immediately after thread trimming.

- 0 : Normal (Only needle up / down compensating stitching operation)
- 1 : One stitch compensating stitching operation (upper stop → upper stop) is performed only when aforementioned changeover is made.

㉒ **Setting of max. number of rotation of the sewing machine head (Function setting No.96 S-MAX)**

This function can set the max. number of rotation of the sewing machine head you desire to use. Upper limit of the set value varies in accordance with the sewing machine head to be connected.

- 50 to Max. [sti/min]

6-18. External interface

External interface means the section to connect the operation panel and the system which is different from the operation panel.

For the use and details of function, please ask our business office.

(1) Media slot

Media slot is installed in the face cover located on the left side of operation panel.

(2) RS-232C port

RS-232C connector is installed in the rubber cap located on the back side of operation panel.

(3) General input port (Production control switch connecting connector)

General input connector, CN105 is installed in the cord outlet cover located on the back side of operation panel.

7. SEWING

7-1. Adjusting the thread tension



WARNING :

In case of thread-breakage. It may occur that the thread tangles on the thread take-up lever. In this case, remove the thread tangling around the thread take-up lever by raising the thread take-up cover. At this time, be careful not to cut your fingers with the knife.

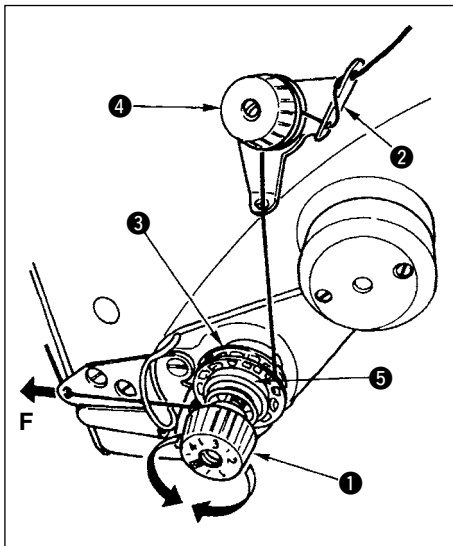

(1) Adjusting the needle thread tension

- 1) Adjust the needle thread tension using the tension nut ①.
Turning the tension nut clockwise increases the needle thread tension, or counterclockwise decreases it.

1. If the thread tension of pre-tension ② is too low, the thread may slip out of rotary disc ③. Adjust the thread tension of the pre-tension, using pre-tension adjusting nut ④ taking care of tension balance between the pre-tension and the rotary disc.
2. When setting the needle thread tension, draw the thread in the direction F to check that rotary disc ③ smoothly rotates with no slippage. When the rotary disc slips, tighten pre-tension adjusting nut ④.
3. Thread tension disc felt ⑤ is a consumable part. When rotary disc ③ slips, there is a possibility that the thread tension disc felt has been consumed. Replace the felt with new one (Part No. : 22528509 x 4 pcs.).
4. When thick thread (approximately #30 or lower) is used for needle thread, thread tension is apt to be insufficient with the rotary tension controller of the standard delivery. In this case, use the optional thread tension disk asm. (part No. : 40017095).

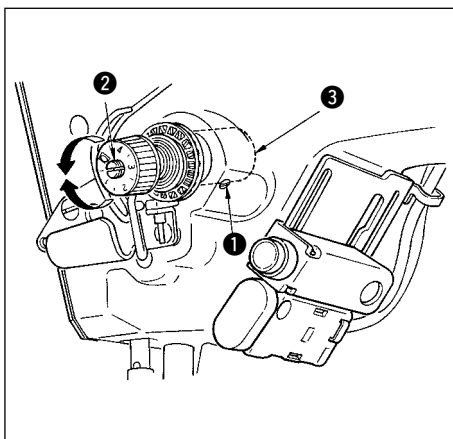

(2) Adjusting the thread take-up spring

- 1) To change the tension of the thread take-up spring, firmly tighten the screw ① which fastens the tension post socket to the machine arm and insert the blade of a screwdriver into the slot in the tension post ② to adjust the tension of the thread take-up spring.
Turn it clockwise to increase.
Turn it counterclockwise to decrease.
- 2) To change the amount of thread taken by the thread take-up spring, loosen the clamping screw ① of the tension post socket and turn the tension post socket ③.
Adjustable range of the amount of thread taken by the thread take-up spring : 6 to 10 mm

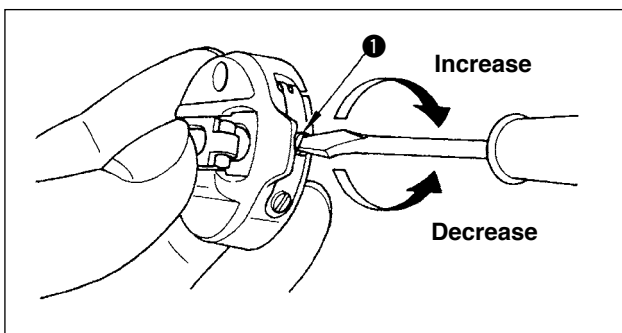

(3) Adjusting the bobbin thread tension

- 1) The tension of the bobbin thread is adjusted by turning the tension adjusting screw ①.
Turn it clockwise to increase.
Turn it counterclockwise to decrease.

7-2. Adjusting the pressure of the presser foot



WARNING :

To protect against possible personal injury due to abrupt start of the machine, be sure to start the following work after turning the power off and ascertaining that the motor is at rest.

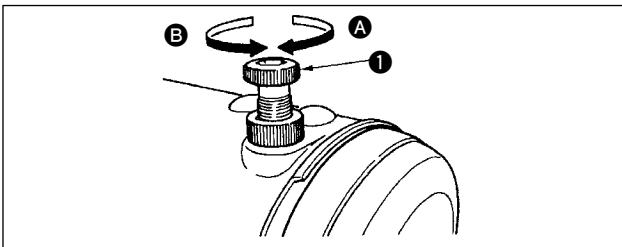

- 1) Turn the presser spring regulator ① clockwise ① to increase the pressure given by the presser foot.
- 2) Turn the presser spring regulator counterclockwise ② to decrease it.

7-3. One-touch type reverse feed stitching mechanism

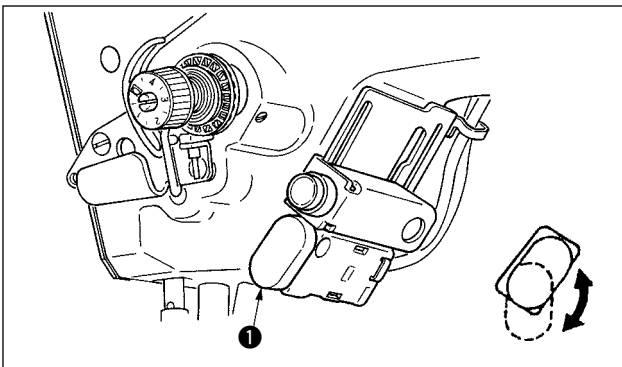

(1) How to use the reverse feed switch lever

- 1) Press reverse feed switch ①, and the sewing machine will immediately run in the reverse direction to perform the reverse feed stitching.
- 2) Reverse stitching is performed as long as you keep the lever held pressed down.
- 3) Release the switch lever, and the machine will immediately run in the normal direction.
- 4) Reverse feed switch ① can be used in two positions by turning it.

(2) Height of the switch



WARNING :

To protect against possible personal injury due to abrupt start of the machine, be sure to start the following work after turning the power off and ascertaining that the motor is at rest.

A. In case of the machine with the auxiliary thread take-up lever

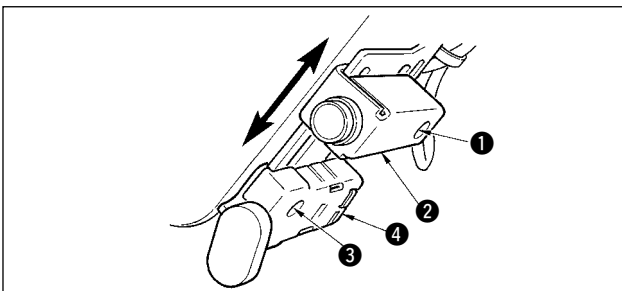

- 1) Loosen setscrew ① and adjust up or down mirror switch ②.
- 2) Loosen setscrew ③ and move up or down reverse feed switch ④ to adjust the height.

* The position of reverse feed switch ④ and mirror switch ② can be reversed.

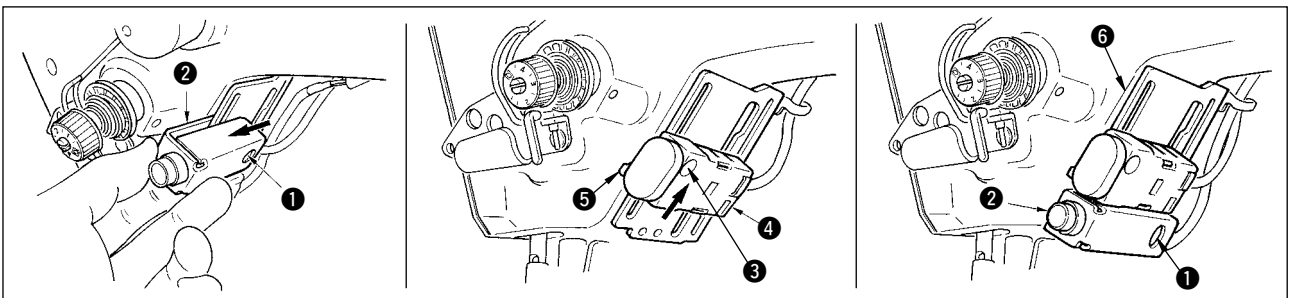

- 3) Loosen setscrew ① and remove mirror SW ②.
- 4) Slightly loosen setscrew ③, move upward reverse feed switch ④ and guide ⑤, and fix the switch with guide ⑤ and setscrew ③.
- 5) Put mirror SW ② in installing base ⑥ and fix it with setscrew ①.
(Put mirror SW ② in installing base ⑥ so that the installing base ⑧ is inserted in the mirror SW ②.)
(Note) Freely adjust the height of the respective switches.

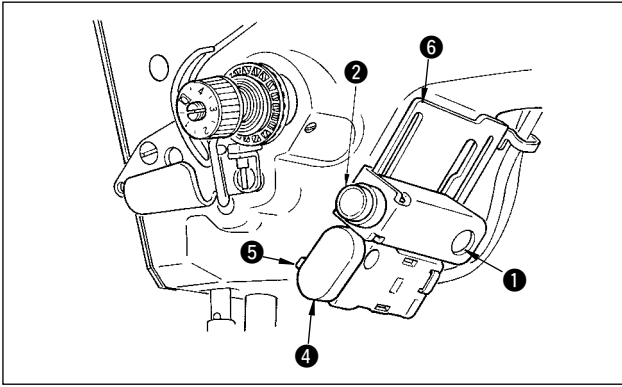

* The position of reverse feed switch ④ and mirror switch ② can be reversed.

When changing the position of the switch in case of “A. In case of the machine with the auxiliary thread take-up lever”, refer to the items 3) through 5).

(Note) Freely adjust the height of the respective switches.

7-4. Pattern 2 (fagoting) sewing

When performing the fagoting sewing, use the optional gauge for fagoting below.

[Example of installing optional gauge for fagoting]

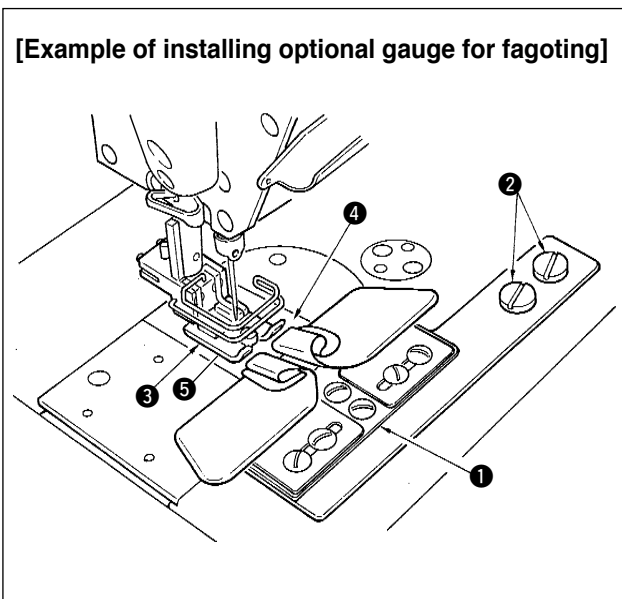

1. Gauges used with LZ-2285N, 2285 and 1285 can be used.

2. When using the optional gauge for fagoting, the wiper device can not be used.

3. When performing fagoting sewing using optional fagoting gauge, set presser ③ so that the pressure of right and left soles of the presser is equal and perform micro lifting by approximately a sheet of paper. Then the slippage of right- and left-hand side materials can be prevented.



For the micro-lifting mechanism of the presser foot, refer to P.128.

	Part No.	Description	Q'ty
①	MAM09700BA0	Upturn folder for fagoting (asm.)	1
②	SS5110710SP	Setscrew for the above folder	2
③	22591564	Presser (asm.)	1
④	10061554	Throat plate (asm.)	1
⑤	10064004	Feed dog	1

* For the details of setting procedure of the patterns, see p.65.

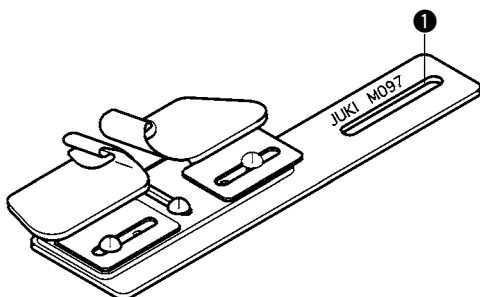

Downturn folder type for fagoting (asm.) can be supplied as well.
Part No. : MAM097000A0

7-5.Hand switch

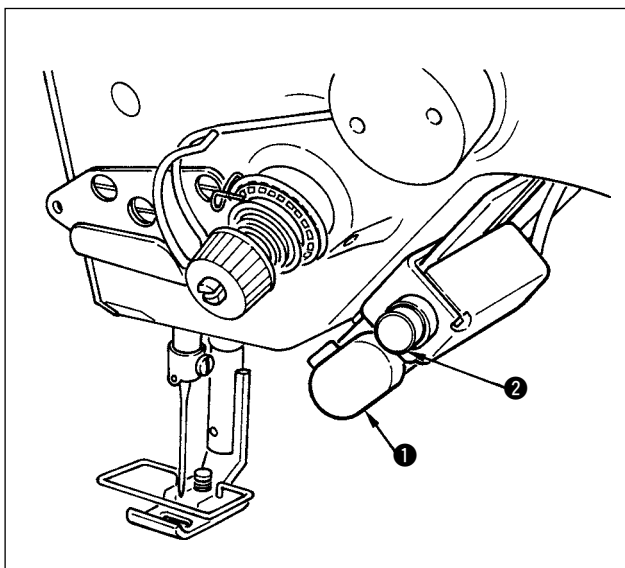

- 1) Reverse feed switch ①
Press reverse feed switch ① and reverse feed is performed.
When it is released, normal feed is performed.
- 2) Mirror inversion switch ②
When scallop, custom pattern or continuous stitching is selected, the switch becomes a mirror inversion switch.

Mirror inversion means the function that the reverse pattern sewing is performed after pressing the mirror inversion switch during temporary stop of sewing.

(For the details, refer to the mirror function setting, p.101.④)

For the adjustment of the height, see p.124.

■ Sewing procedure (Example : scallop)

- 1) Stop the sewing machine at the position you desire to perform mirror inversion during sewing.
- 2) Press the mirror inversion switch ②. When the mirror inversion switch is received, LED lights up.
(The switch can receive only when the sewing machine stops and dose not receive when the sewing machine is running.)
- 3) Perform mirror inversion sewing with the sewing machine.
- 4) Perform thread trimming or press again the mirror inversion switch to complete the inversion sewing.

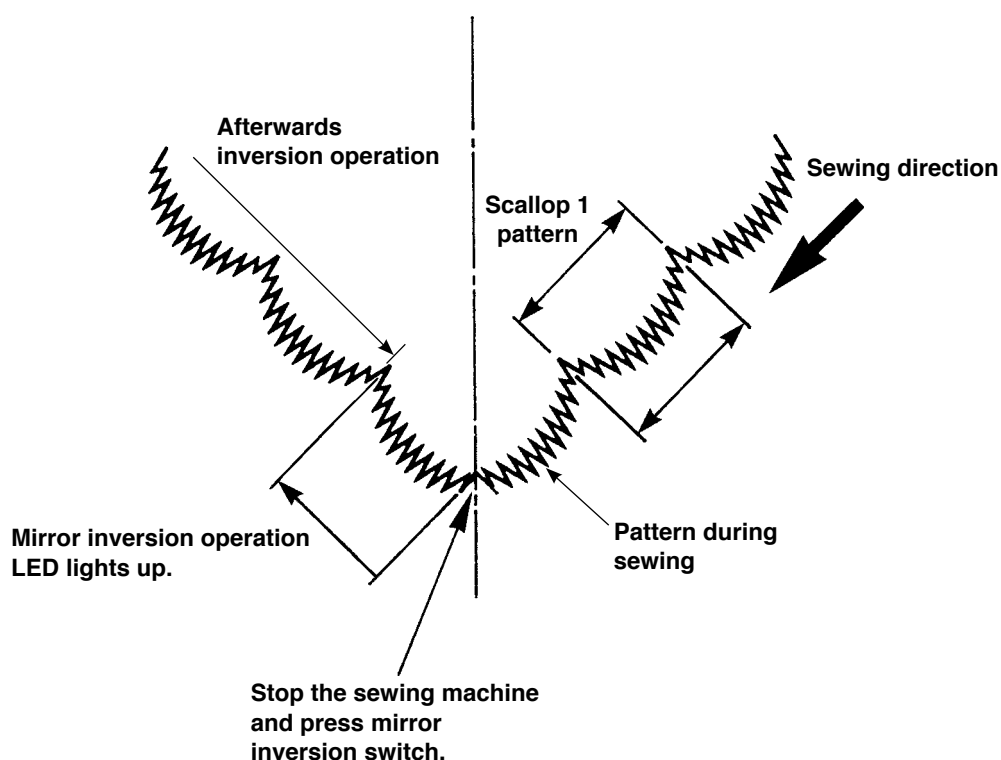

8. STANDARD ADJUSTMENT

8-1. Adjusting the amount of oil in the hook



WARNING :

Turn OFF the power before starting the work so as to prevent accidents caused by abrupt start of the sewing machine.

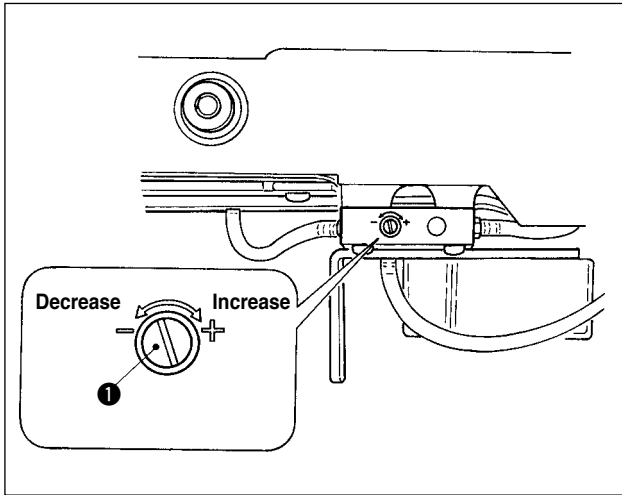

Adjustment of the amount of oil in the hook is performed with oil amount adjustment screw ①.

(1) Adjustment procedure

Tighten (turn clockwise) oil amount adjustment screw ① to increase the amount of oil in the hook, or loosen (turn counterclockwise) to decrease it.



1. When adjusting the amount of oil in the hook, perform the adjustment in a way of reducing the oil amount after somewhat increasing it.
2. The amount of oil in the hook has been adjusted at the max. number of revolution at the time of delivery. When you always use the sewing machine at low speed, there is a possibility that trouble occurs due to the lack of amount of oil in the hook. When the sewing machine is used always at low speed, perform the adjustment of the amount of oil in the hook.
3. There is a possibility of causing oil leakage from the hook shaft section since oil does not return to the oil tank when oil amount adjustment screw ① is used in fully-tightened state. Do not use the screw in fully-tightened state. In addition, when the amount of oil in the hook is not obtained unless oil amount adjustment screw ① is near in fully-tightened state, it is considered that hook shaft oil wick (JUKI Part No. 11015906) is clogged or the like. Replace the hook shaft oil wick. For the replacing procedure, refer to (10) Replacing the hook shaft oil wick of 9. MAINTENANCE.

8-2. Adjusting the amount of lubricating to face plate section



WARNING :

Turn OFF the power before starting the work so as to prevent accidents caused by abrupt start of the sewing machine.

It is not necessary to adjust the amount of lubricating to face plate section since it has been factory-adjusted at the time of delivery. (Oil amount adjustment screw ② in the face plate section lubricating tank is hidden with stop plug ① since it is not necessary to be adjusted.)

When the adjustment is performed by mistake (mistaken as the adjustment of oil amount in the hook), re-adjust as shown below.

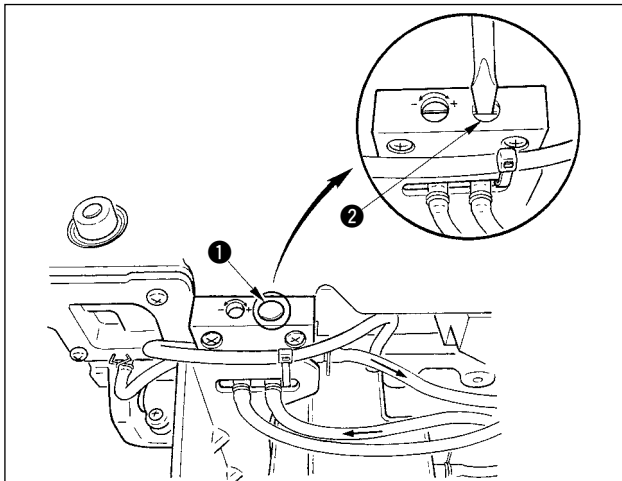

- 1) Remove stop plug ①, and when lightly tightening the adjustment screw ②, return the screw by approximately 0.6 turn from the stop position.



Lightly tighten the screw ②. Be careful that it is not excessively tightened.

- 2) In case of the normal state, the flow of oil can be confirmed (direction of the arrow in the illustration). In case the flow is stopped, be sure to adjust. (Worn-out of the mechanism of face plate section will be caused.)

8-3. Adjusting the height of the presser bar

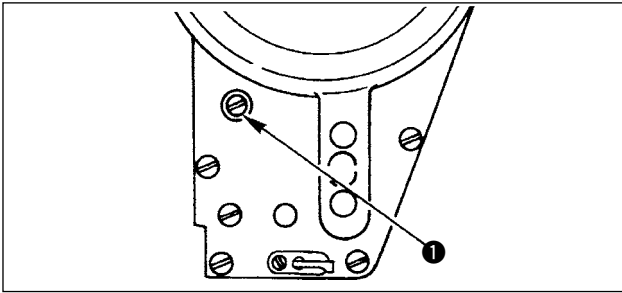

- 1) To change the height of the presser bar or the inclination of the presser foot, loosen the presser bar connection screw ❶ and perform the adjustment properly.
- 2) After the adjustment, securely tighten the screw.

8-4. Adjusting the micro-lifting mechanism of the presser foot



WARNING :

To protect against possible personal injury due to abrupt start of the machine, be sure to start the following work after turning the power off and ascertaining that the motor is at rest.

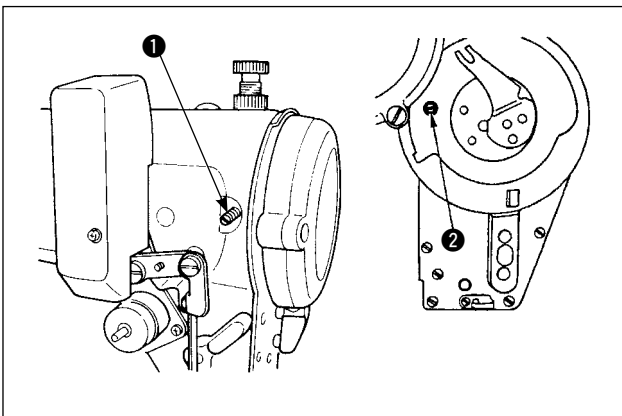

Some type of material needs to be sewn with the presser foot slightly lifted. In this case, perform this adjustment following the procedure described below.

- 1) Loosen the setscrew ❶ in the presser foot micro-lifter.
- 2) Turn the presser foot micro-lifting screw ❷ clockwise through the hole in the face plate until the presser foot is raised as desired. Then, tighten the screw ❶.



If you do not use the micro-lifting mechanism of the presser foot, fully return the presser foot micro-lifting screw ❷ to its home position. The standard of lifting amount of the presser foot is as thick as a sheet of paper.

8-5. Height and inclination of the feed dog



WARNING :

To protect against possible personal injury due to abrupt start of the machine, be sure to start the following work after turning the power off and ascertaining that the motor is at rest.

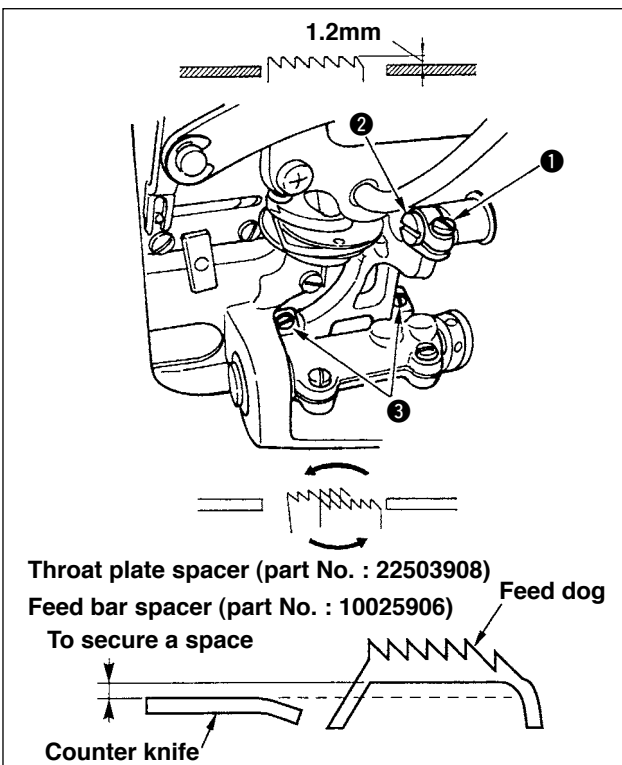

- 1) To adjust the height of the feed dog, loosen the screw ❶ and turn the feed driving link pin ❷ using a screwdriver.
- 2) The standard height of the feed dog is 1.2 mm.
- 3) To adjust the inclination of the feed dog, loosen the two screws ❸ and turn the eccentric shaft inserting a screwdriver through the adjustment hole in the machine bed.
- 4) For the machine with a thread trimmer, there can be no space between the counter knife and the underside of the feed dog when adjusting the feed mechanism (change in height and timing) or using a commercially-available feed dog. In this case, place a feed bar spacer (part No. : 10025906) under the feed mechanism and a throat plate spacer (part No. : 22503908) under the throat plate so as to secure a space between the counter knife and the underside of the feed dog.

The standard inclination of the feed dog is obtained by adjusting the feed dog so that it becomes horizontal when it rises above the top surface of the throat plate.

8-6. Hook adjusting mode



When the hook adjusting mode is set, it is possible to adjust the hook by turning the handwheel.

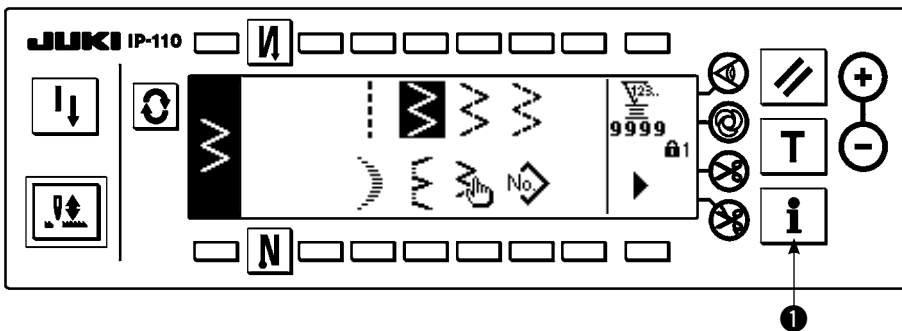

- 1) Turn ON the power. When the needle bar is not in the UP position, turn the handwheel to bring the needle bar to its UP position.
- 2) Press switch ❶ for approximately three seconds to display the information screen.

■ Information screen

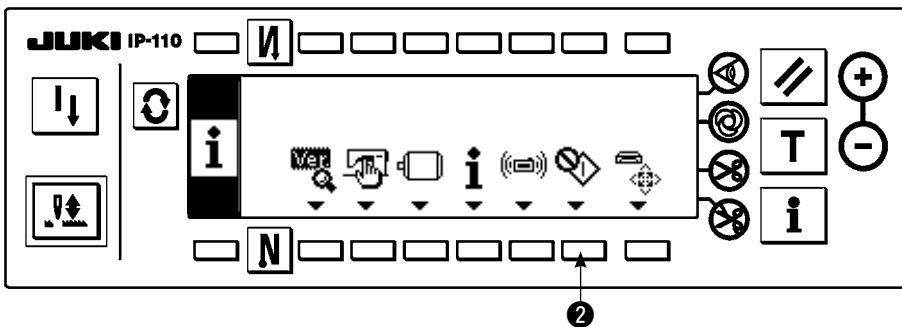

- 3) Press ❷ to enter the hook adjusting mode.
- 4) Zigzag patterns of straight stitch and 2-step zigzag stitch can be selected in the hook adjusting mode.

Straight stitch

- ❸ : Changeover of straight stitch and 2-step zigzag stitch can be performed.
- ❹ : Position of stitch base line is set with “+” and “-”.

■ Hook adjusting mode setting screen < Straight stitch >

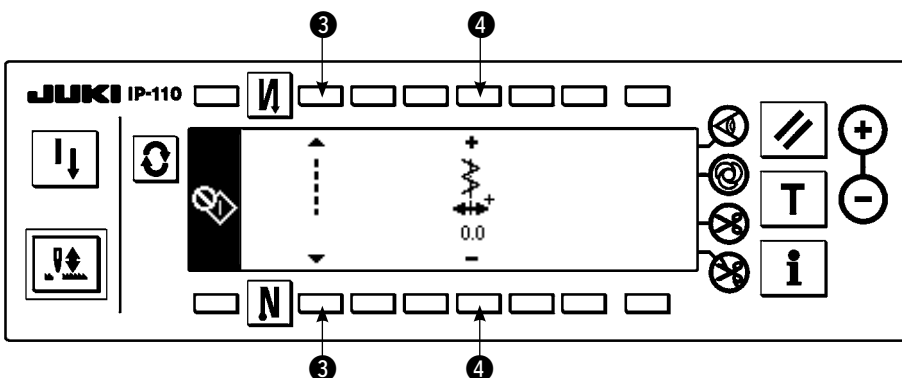

2-step zigzag stitch

- ❺ : Changeover of straight stitch and 2-step zigzag stitch can be performed.
- ❻ : Zigzag width is set with “+” and “-”. (Initial value is set to 8 mm.)
- ❼ : Position of stitch base line is set with “+” and “-”.

■ Hook adjusting mode setting screen < 2-step zigzag stitch >

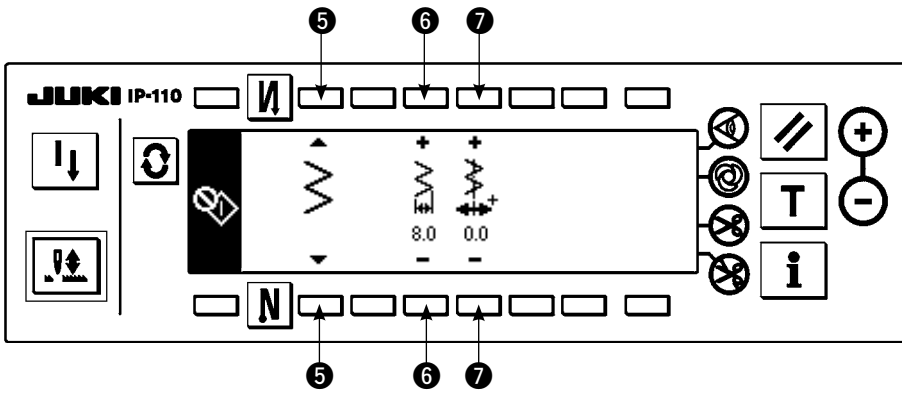

5) Turn ON/OFF the power to return from the hook adjusting mode to the normal sewing mode.

* Sewing machine does not work even when the front part of the pedal is depressed during the hook adjusting mode.

* Needle throwing works by turning the handwheel by hand.

* Needle bar moves when the set value is changed at needle UP position.



It is possible for zigzag width and position of the stitch base line to set up to the width of 10 mm regardless of the max. zigzag width limitation at the time of the hook adjusting mode. When using the hook adjusting mode for the machine to which presser foot, gauge, etc. are attached, be very careful in performing the adjustment.

8-7. Attaching / removing the hook



WARNING :

To protect against possible personal injury due to abrupt start of the machine, be sure to start the following work after turning the power off and ascertaining that the motor is at rest.

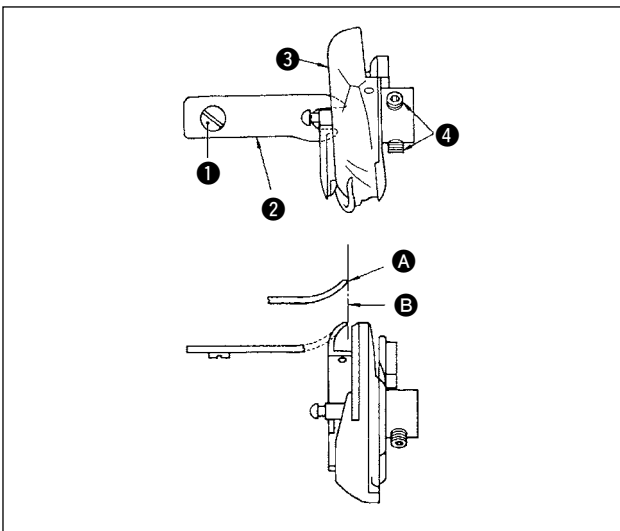

When you replace the sewing hook, remove it in the following procedures ;

- 1) Turn the handwheel until the needle reaches to its highest position.
- 2) Remove the needle, presser foot, throat plate, feed dog and bobbin case from the machine.
- 3) Remove the setscrew ① and take out the bobbin case positioning finger ②.
- 4) Loosen the two screws ④ and remove the sewing hook ③.

Reverse the above procedures when inserting the sewing hook. At this time, make sure that top end **A** of the bobbin case positioning finger is aligned with line **B**. as shown in the figure on the left. Never let **A** protrude from line **B**.



Part No. of hook ③ is 22525877.

Do not use the hook other than that designated by JUKI.

8-8. Adjusting height of the needle bar



WARNING :

To protect against possible personal injury due to abrupt start of the machine, be sure to start the following work after turning the power off and ascertaining that the motor is at rest.

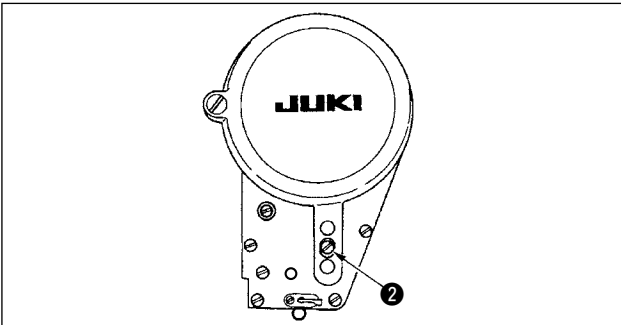
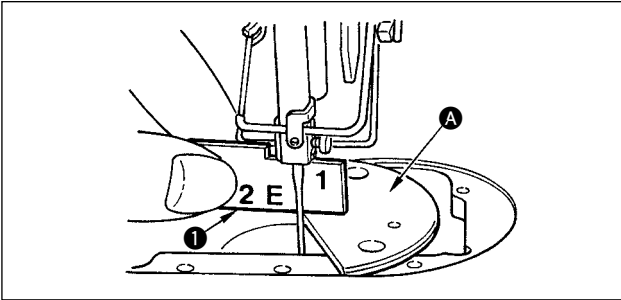

- 1) Set the zigzag width to "0". Bring the needle to the center of the zigzag stroke.
- 2) Remove the presser foot, throat plate, semicircle plate and feed dog.
- 3) Place a semicircle plate on the plane, to which the throat plate is to be attached, of the bed. Loosen setscrew ②, and adjust so that from the top surface of semicircle plate ① to the bottom end of the needle bar is as high as "1" of timing gauge ①.

1. Thickness of the semicircle plate is different from that of the throat plate. Be sure to use the semicircle plate when adjusting the height of the needle bar. Be sure to perform the adjustment with zigzag width set to zero and with the needle positioned at the center of the zigzag stroke.



2. Use the timing gauge on which the indication "E" is engraved which has been supplied as accessories. (Part No. 22536502)

8-9. Adjusting the needle-to-hook timing and the needle guard



WARNING :

To protect against possible personal injury due to abrupt start of the machine, be sure to start the following work after turning the power off and ascertaining that the motor is at rest.

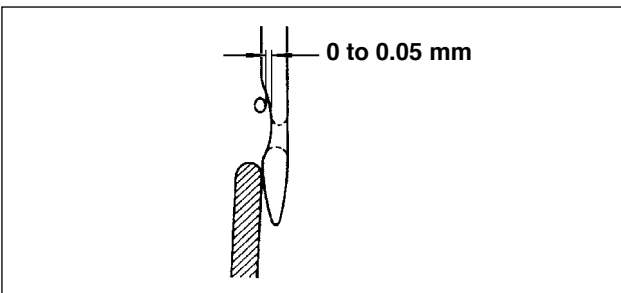
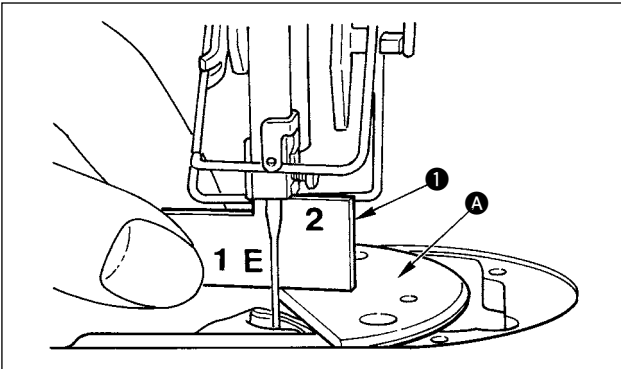

(1) Positioning the hook

- 1) After the completion of the adjustment of the needle bar height, adjust so that the blade point of the hook comes to the center of the needle at the height of the "2" of timing gauge 1 which has been supplied as accessories.
- 2) At this time, the blade point of the hook should slightly come in contact with the needle when the needle guard does not touch the needle.

(2) Confirmation

Bring the needle to the leftmost position of the zigzag stroke at the time of the standard zigzag width of 8 mm, and confirm that the top end of the needle eyelet is spaced 0.2 to 0.5 mm away from the blade point of the hook. If the zigzag width of 10 mm is used or the shape of indented part of the needle is different from that of indented part of the needle at the time of delivery, re-adjust the height of the needle bar.

(3) Adjusting the needle guard

- 1) Maximize the zigzag width. Bend the needle guard to adjust so that the needle does not come in contact with the blade point of the both at the leftmost and rightmost positions of the zigzag stroke. At this time, adjust the clearance provided between the needle and the blade point of the hook to 0 to 0.05 mm.
- 2) The needle guard functions to keep the needle away from the blade point of the hook, thereby preventing damage to the blade point of the hook. Whenever you have replaced the hook with a new one, be sure to adjust the position of the needle guard.



When thread breakage has occurred, there is a case where thread is caught in the hook. Be sure to perform sewing after removing the thread caught in the hook.

8-10. Adjusting the stop position of the needle

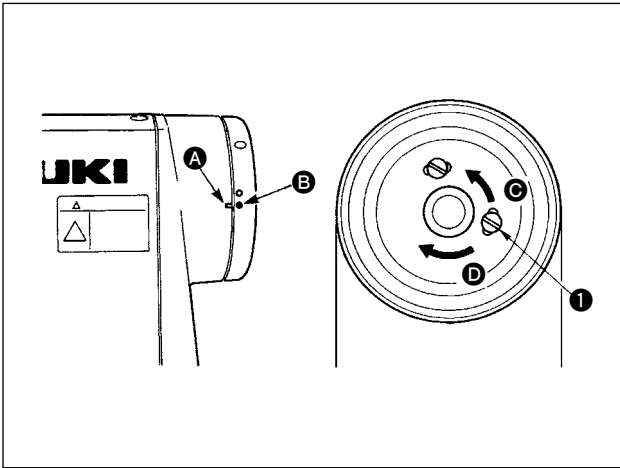

(1) Stop position of the needle after thread trimming

- 1) The needle stops at the standard stop position when marker dot **A** engraved on the handwheel cover is aligned with white marker dot **B** engraved on the handwheel.
- 2) Stop the needle at the highest position of its stroke, loosen screw **1**, and adjust the stop position of the needle by moving screw **1** within the slot.
 - ① Move the screw in the direction **C** to advance the timing to make the needle stop.
 - ② Move the screw in the direction **D** to retard the timing to make the needle stop.



Do not operate the sewing machine with screw **1 loosened. Loosen the screw only, and do not removed it.**

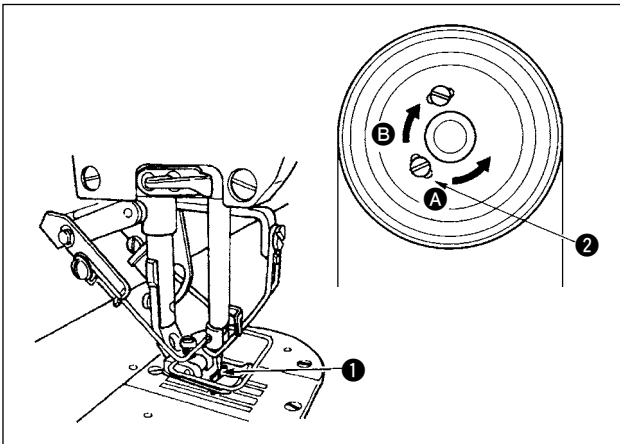

(2) The lowest stop position of the needle

When you return the pedal to its neutral position after having depressed the front part of it, the needle stops at the lowest stop position. As in the case of the adjustment of the highest stop position of the needle, stop the needle **1** in the lowest position of its stroke, loosen the screw **2**, and adjust the lowest stop position of the needle by moving the screw **2** within the slot. Move the screw in the direction **A** to advance the timing to make the needle stop or in the direction **B** to retard it.



Do not adjust screw **2. It has been factory-adjusted at the time of delivery and needle sway will be caused if it is adjusted.**

8-11. Adjusting the thread trimmer



WARNING :

To protect against possible personal injury due to abrupt start of the machine, be sure to start the following work after turning the power off and ascertaining that the motor is at rest.

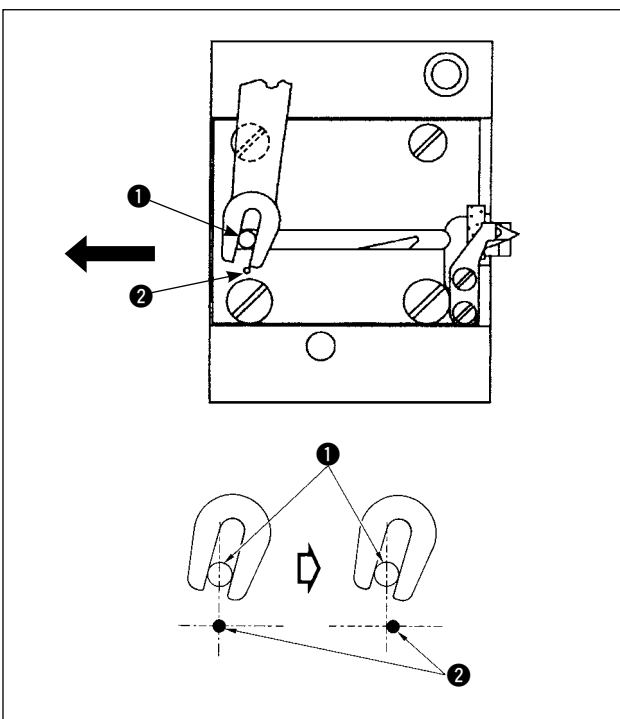

(1) Initial position of the moving knife

When the moving knife is in its initial position, the moving knife pin **1** should be aligned with the engraved marker dot **2** as shown in the figure on the left.



1. When the gauge size which is more than that delivered as standard or the gauge size of other manufactures is used, and the counter knife interferes with the feed dog, loosen nut **3**, move the initial position of moving knife pin **1** to the left from engraved maker dot **2** by approximately one half of engraved marker dot **2** and fix the pin.
2. Guarantee of the sharpness of the thread trimmer knife unit is #80 to #50. When using thick threads thicker than these Nos., replace the knife with thread trimmer knife unit for thick thread (Part No. : 22556054).

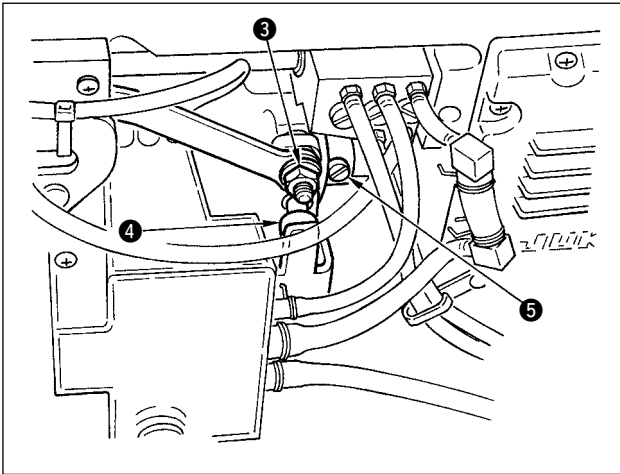

If the initial position of the moving knife is not correct

Loosen the nut ③, and move the moving knife to the right or left until the pin ① meets the marker dot ②. Then, tighten the nut ③.

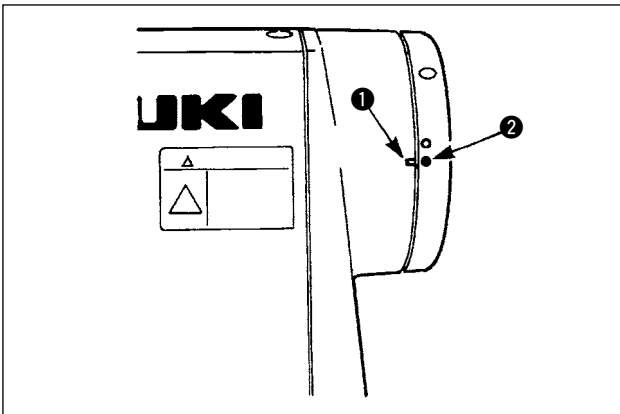

(2) Adjusting the thread trimming timing

Put roller ④ in the cam groove. Now, gradually turn the handwheel in the reverse direction. The handwheel will go no further when marker dot ① engraved on the handwheel cover is aligned with red marker dot ② engraved on the handwheel.

To adjust the thread trimmer cam, align the red marker dot on the handwheel cover with the red marker dot on the handwheel, put the roller in the groove of the thread trimming cam, and gradually turn the handwheel in the direction opposite to the direction of rotation of the hook driving shaft until it will go no further. Now, tighten two screws ⑤.

8-12. Adjusting the needle thread feeding device



WARNING :

To protect against possible personal injury due to abrupt start of the machine, be sure to start the following work after turning the power off and ascertaining that the motor is at rest.

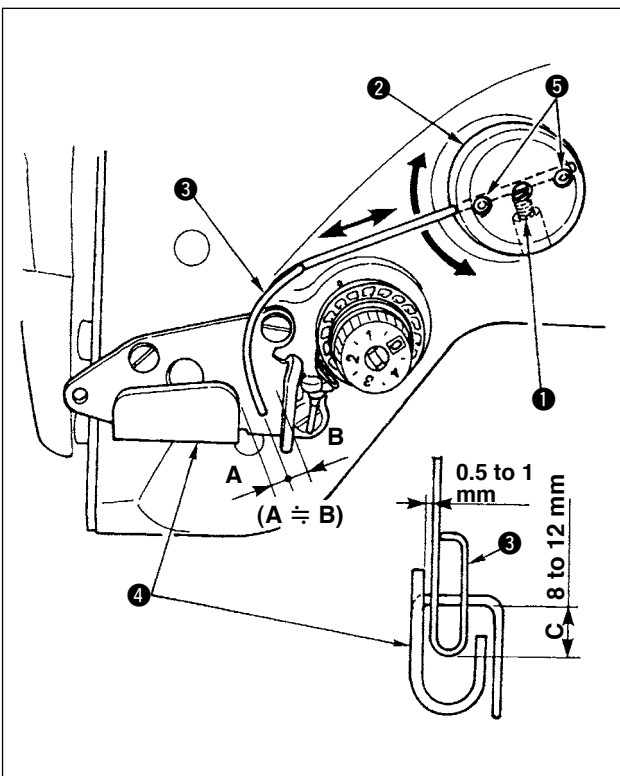

Standard position of the feeding wire

- 1) Loosen screw ①.
- 2) Turn the feeding wire together with feeding wire installing base ②, adjust the installing position of the feeding wire so that a distance of C (8 to 12 mm) is provided between the top end of feeding wire ③ and the guide portion of thread take-up thread guide A ④, and tighten screw ①.



At this time, leave a space of 0.5 to 1 mm between the feeding wire and the top surface of the thread take-up thread guide A.

- 3) Finely adjust with setscrews ⑤ so that the top end of the feeding wire is placed approximately in the center (A ≅ B) of the thread take-up thread guide A.

When turning OFF the feeding device :

It is possible to turn OFF with the function setting No. 89 described in the function setting list.

When needle thread feeding amount is desired to be increased :

- Loosen setscrew ① and adjust the relation between A and B to A > B.
- Loosen setscrew ① and when the whole feeding wire installing base ② is adjusted to the upward direction (decrease the value, C), the feeding amount can be increased.

8-13. Adjusting the bird's nest prevention (CB) type wiper



WARNING :

To protect against possible personal injury due to abrupt start of the machine, be sure to start the following work after turning the power off and ascertaining that the motor is at rest.

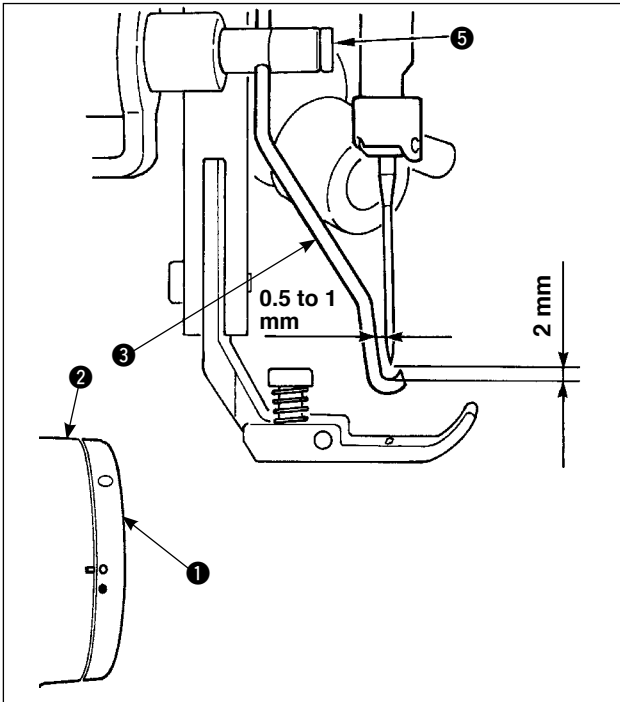

■ Position of the wiper

- Adjust the white marker dot on the handwheel ① to the position where it is aligned with the marker dot on the pulley cover ②, quietly press wiper link A to move wiper ③. The wiper recedes by the ratchet when going and the position where the wiper returns to its home position is in the center of needle or the position exceeding the center of needle. Besides, adjust with wiper setscrew ⑤ so that when wiper ③ comes to the position of the center of needle when returning, the clearance between the wiper and the needle tip should be approximately 2 mm and that between the wiper and the side of needle should be approximately 1 mm.

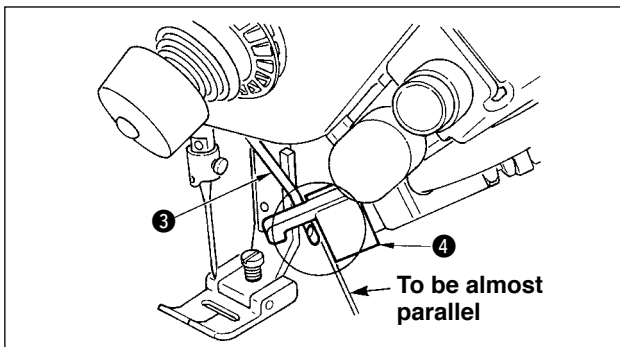
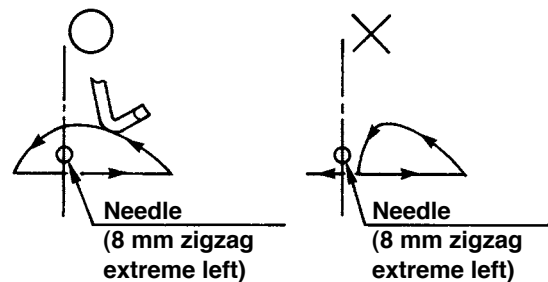

- The top end plane of wiper ③ should be positioned to be almost parallel to the end plane of clamp head ④. Besides, set the clamp head so that the upper side is the protruding section.

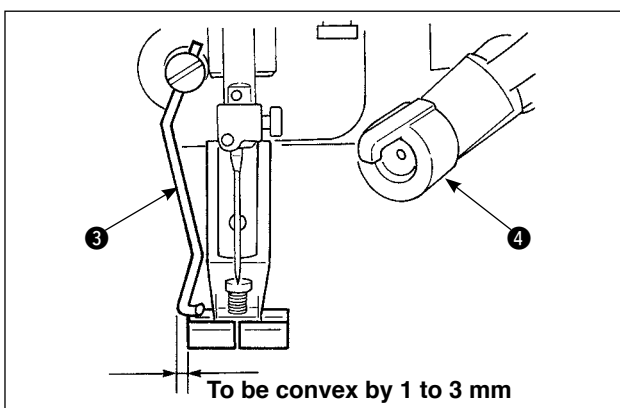

- Adjust the maximum stroke of the wiper to the position of 1 to 3 mm from the left end plane of the presser of standard delivery.
 - Presser (asm.) of standard delivery (Part No. 40003542)
 - Optional Presser (asm.) for narrow width (Part No. 40003549)



- In case of the process starting from the reverse feed, there is the possibility that needle breakage or the like may occur since needle thread is not cut. Be sure to use the bird's nest prevention (CB) device in the process starting from the normal feed.
- Guarantee of the sharpness of needle thread cutting knife of the bird's nest prevention (CB) type is #80 to #50. Do not use the thread thicker than the above range.
- When zigzag width or feed amount is increased, there is the possibility that needle thread enters the needle thread cutting groove of the presser and is cut, depending on the needle thread bend of zigzag pattern. In this case, replace the presser with the general presser (presser without knife).

8-14. Replacing procedure of the bird's nest prevention (CB) type presser knife



WARNING :

To protect against possible personal injury due to abrupt start of the machine, be sure to start the following work after turning the power off and ascertaining that the motor is at rest.

The needle thread cutting knife is mounted on the presser delivered as standard for the bird's nest prevention (CB) type.

The needle thread cutting knife is an article of consumption. When the knife becomes dull, replace it with a new one.

Name of part : Knife (ceramic) Part No. : 11434206

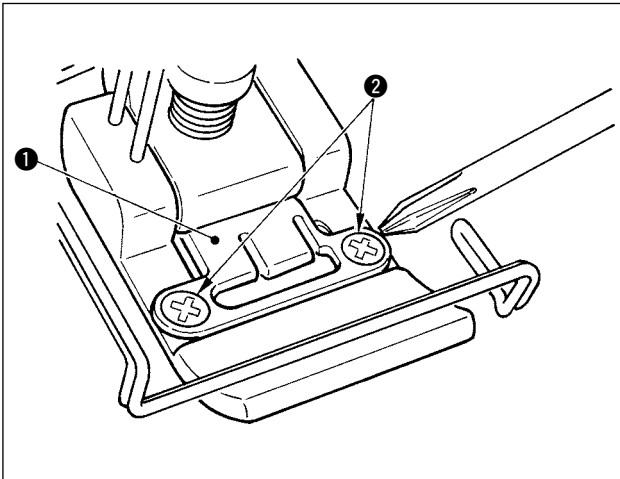

- 1) Remove two setscrews ② in the knife fixing plate using a precision screwdriver and remove knife fixing plate ①.

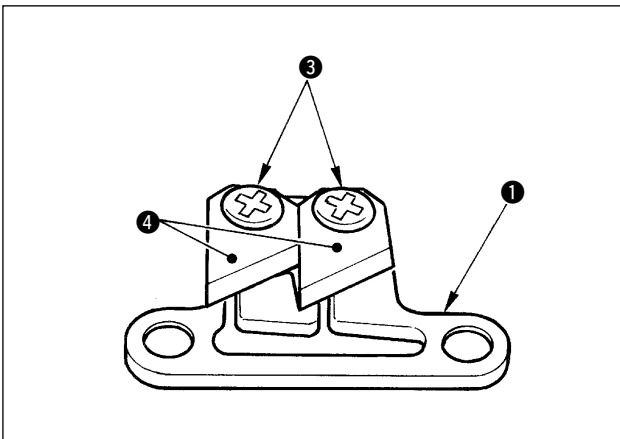

- 2) Remove two setscrews ③ in the knife using a precision screwdriver and remove knife (ceramic) ④ from fixing plate ①. Then replace the knife.

• When replacing knife ④ (ceramic), be careful of the injury to the fingers.

• When replacing knife ④ (ceramic), be careful of its direction and position. (It should be almost parallel to knife fixing plate ①.)

■ When using the bird's nest prevention type as the needle thread clamp type

When using as the needle thread clamp type, perform the setting below.

[Example of use] · When using as the interlacing failure prevention at the time of sewing from the cloth end.
 · When using the normal presser. (presser without knife)

1. Set the value of function setting No.19 to 1. (Standard "0")
2. Input the setting of number of stitches of releasing needle thread with function setting No. 28. ("0" to 30 stitches)



Needle thread clamp ratio when needle does not enter the cloth excessively drops in comparison with that when needle enters the cloth.

Be sure to operate the wiper on the cloth.

■ When using the bird's nest prevention type as the wiper type

1. Set the value of function setting No. 18 to "0". (Standard 1)

9. MAINTENANCE



WARNING :

To prevent personal injuries caused by electric shock hazards or abrupt start of the sewing machine, carry out the work after turning OFF the power switch and ascertaining that the motor has completely stopped. To prevent personal injuries, when a fuse has blown out, be sure to replace it with a new one with the same capacity after turning OFF the power switch and removing the cause of the blown-out of the fuse.

9-1. Replacing the power fuse

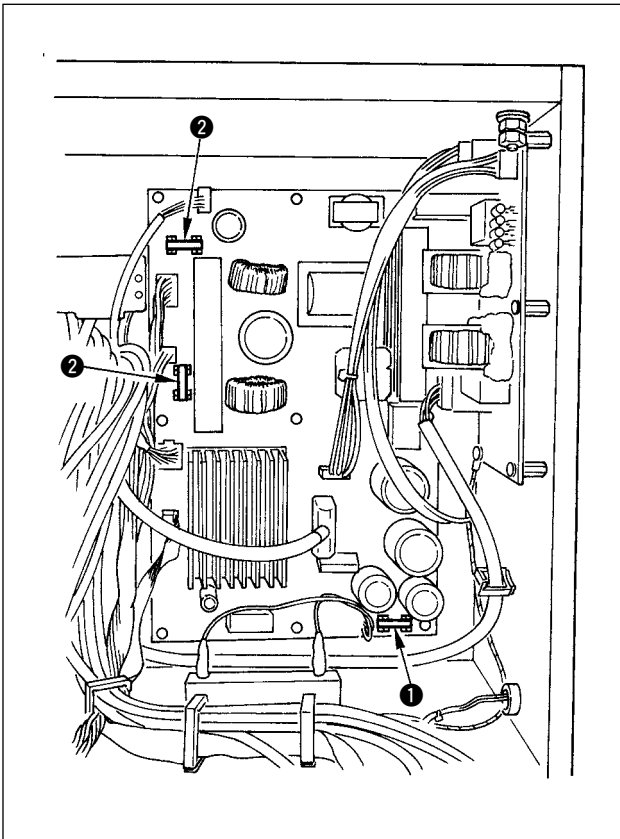

- 1) Confirm that the sewing machine has stopped, and turn OFF the power with the power switch.
- 2) Confirm that the power switch has been turned OFF, and draw out the power cord from the power receptacle. Then, wait for five minutes or more.
- 3) Remove four screws tightening the rear cover of the electrical box and slowly remove the rear cover.
- 4) Hold the glass portion of the fuse to be replaced and remove the fuse.
- 5) Use the fuse with the specified capacity.
 - ① 2A / 250V Time-lag type (HF0078020P0)
 - ② 10A / 250V Time-lag type (HF001301000)

9-2. Adjusting the contrast of the operation panel display

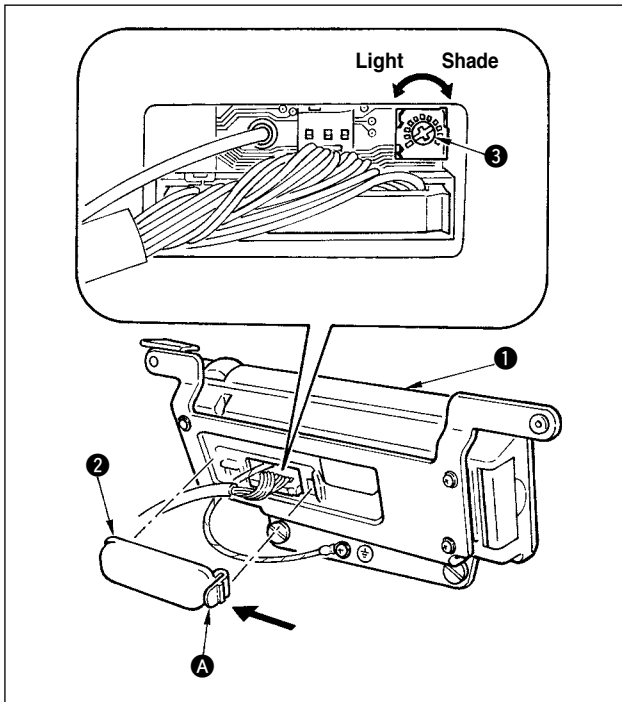

- 1) Press in the direction of arrow mark the click of section **A** of cord outlet cover **2** assembled in the rear of operation panel **1** and remove the cover.
- 2) Turn LCD screen display brightness adjustment variable resistor **3** to adjust the brightness (contrast) of LCD screen.



To prevent the operation panel from breakage, do not touch the circuit board pattern and the connector terminal.

9-3. Draining (Bird's nest prevention (CB) type only)

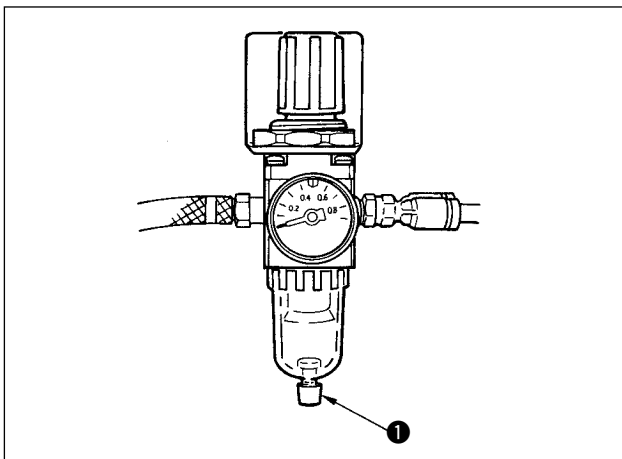

When the regulator becomes filled with water, turn knob **1** for drain counterclockwise.

9-4. Cleaning the dust bag (Bird's nest prevention (CB) type only)

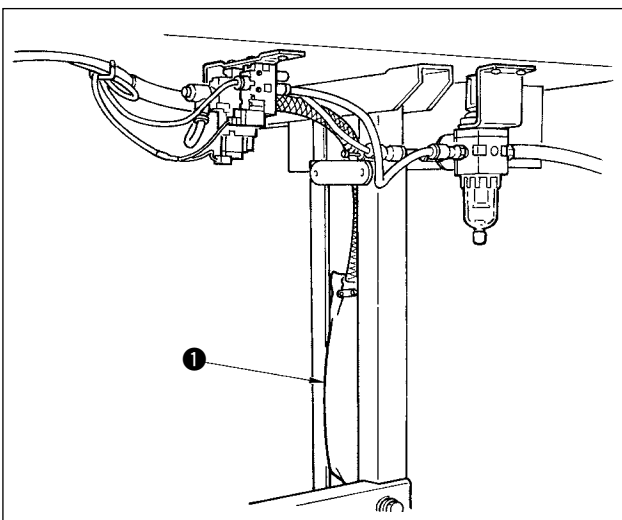

Periodically clean dust bag **1**.

(When the dust bag becomes excessively filled with waste thread, there may be cases where clamp failure occurs.)

9-5. Cleaning the cooling fan installed on the under cover

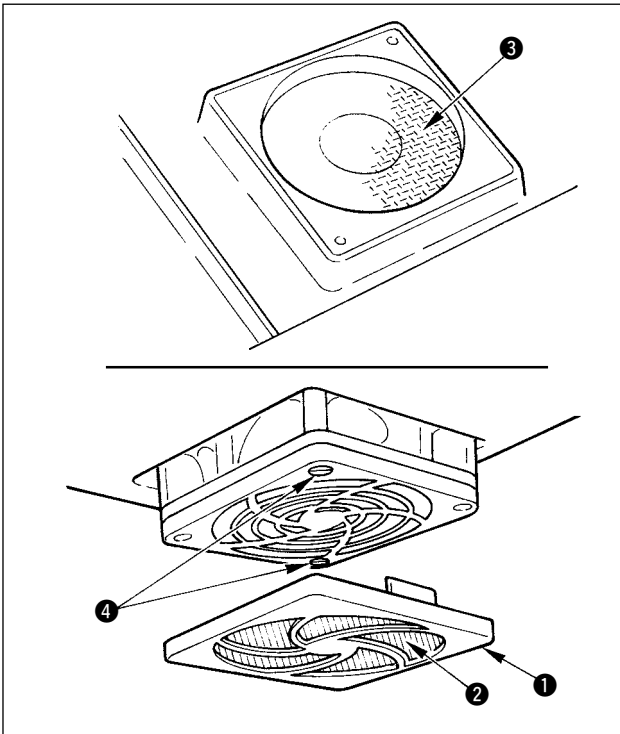

Cloth waste or the like gathers around the cooling fan filter section installed on the lower part of the under cover, and there is a case where cooling effect of the machine head is decreased.

When cloth waste or the like has gathered, remove fan cover ① and take off the cloth waste or the like of filter section ②. In addition, when there is cloth waste or the like in filter section ③, remove filter setscrews ④ and take off the cloth waste or the like of filter section ③.



Be sure to install filters ② and ③ after they have been completely dried up.

9-6. Cleaning the hook section

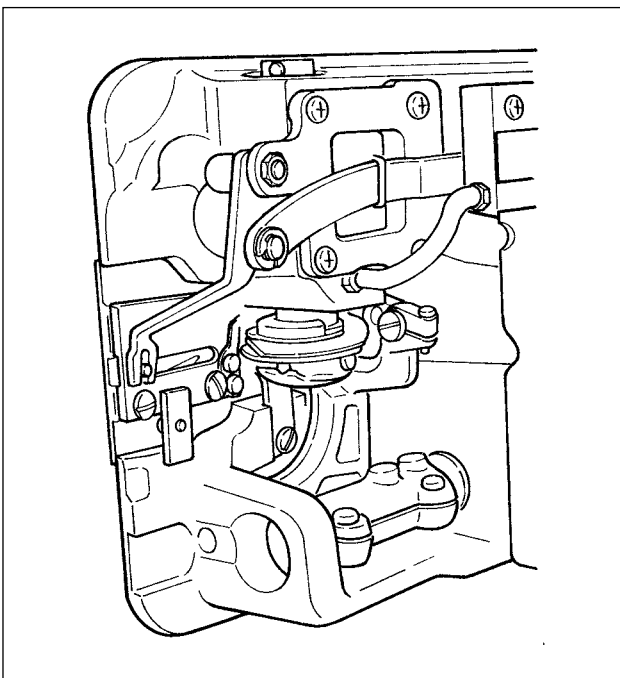

When cloth waste or the like gathers around or adheres to the hook section, trouble (defective sewing, seizure of hook, etc.) of sewing machine will be caused. Periodically clean the section.

9-7. Cleaning the rear cover of the control box

Clean the rear cover when dust or the like gathers on it.

9-8. Cleaning the operation panel screen

Do not wipe the operation panel screen with thinner or strong force.

Lightly wipe the screen with a dry and soft cloth or an alcohol-soaked cloth to clean it.

9-9. Replacing procedure of the hook shaft oil wick



WARNING :

To protect against possible personal injury due to abrupt start of the machine, be sure to start the following work after turning the power off and ascertaining that the motor is at rest.

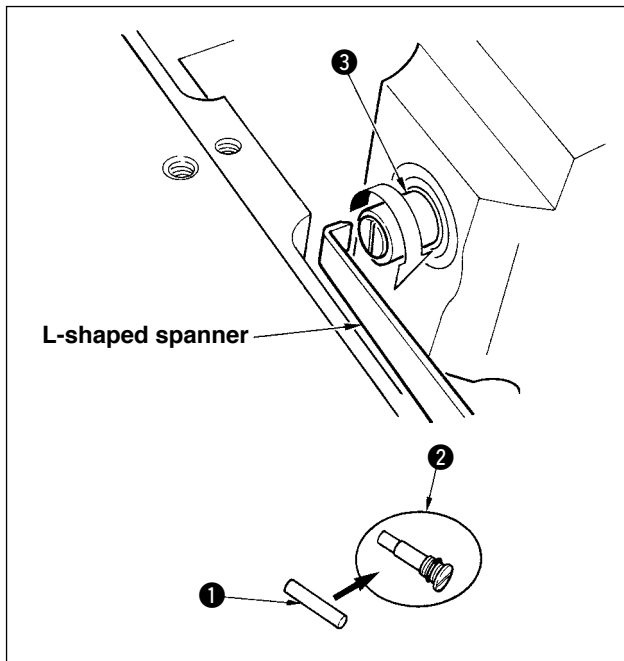

- 1) Hook shaft oil wick ① is mounted on the top end of hook shaft ③. Remove the needle and the parts around the needle (presser foot, needle, throat plate, feed plate, hook and woodruff plate), put a spanner, top end of which is L-shaped to the groove section of hook shaft oil wick screw ②, turn the handwheel in the normal direction of rotation by hand, and draw out the screw.
- 2) Draw out hook shaft oil wick ① from hook shaft oil wick screw ② which has been drawn out and push a new hook shaft oil wick ① (JUKI Part No. : 11015906) to hook shaft oil wick screw ② (JUKI Part No. B1808552000). At this time, be sure to check that hook shaft oil wick ① has entered up to the end of hook shaft oil wick screw ②.
- * When re-assembling, check that the hole at the top end of hook shaft oil wick screw ② is not broken.
- 3) Securely tighten hook shaft oil wick screw ② to the top end of hook shaft ③.

9-10. Applying the exclusive grease

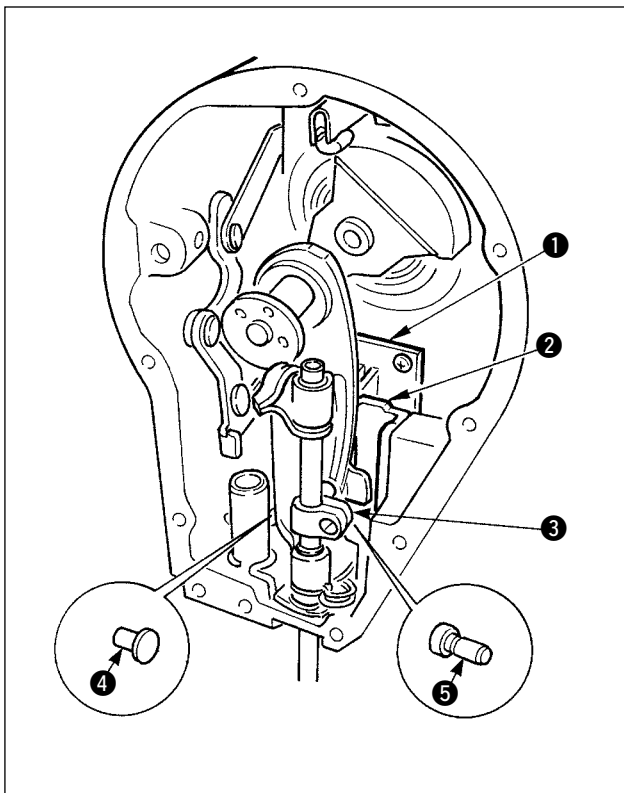

It is effective to periodically replenish the grease using the exclusive grease (grease tube part No. : 40006323) supplied as accessories. (It is not necessary to replenish the grease when the sewing machine is operated under the normal condition. However, when the sewing machine is operated under the severe condition, perform replenishing.) Apply the exclusive grease supplied as accessories to all of the rocking mechanism components (① through ⑤) located inside the face plate section. However, do not apply the grease to the needle bar.

10. AT A TIME LIKE THIS !



In case of the following, check again before you judge the case as trouble.

Phenomenon	Cause	Corrective measure
Buzzer beeps and the sewing machine fails to operate when the machine head is tilted.	The measures described on the left are taken for safety when tilting the machine head without turning OFF the power.	Tilt the machine head after turning OFF the power.
Solenoids for thread trimming, reverse stitching, wiper, etc. fail to work.	In case the fuse has blown.	Check the fuse.
The sewing machine fails to run even when depressing the pedal immediately after turning ON the power. The sewing machine runs when depressing the pedal again after depressing the back part of pedal.	Neutral position of the pedal is slipped. (When changing the spring pressure of pedal, the neutral position may be slipped.)	Execute automatic compensation of neutral position of pedal sensor. (Function setting No. 103)
The sewing machine fails to stop even when the pedal is returned to its neutral position.		
Stop position of the sewing machine varies. (Irregular)	In case the screw of handwheel of the machine is forgotten to be tightened when adjusting the stop position of needle.	Securely tighten the screw of handwheel.
Presser foot does not lift although auto-lifter is installed.	Auto-lifter function is set to OFF.	Select "FL ON" by means of auto-lifter function setting selection. (Function setting No. 23)
	Pedal type is set to KFL.	Change the jumper to PFL setting when lifting the presser foot by depressing the back part of pedal.
	Cord of auto-lifter is not connected to connector.	Correctly connect the cord.
Reverse feed stitching switch fails to work.	Presser foot is lifting by means of auto-lifter.	Operate the switch after the presser foot has come down.
	Auto-lifter function is set to ON although auto-lifter is not installed.	Select "FL OFF" when auto-lifter is not installed. (Function setting No. 23)
The sewing machine fails to run.	Motor output cord (4P) is disconnected.	Correctly connect the cord.
	Connector of motor signal cord is disconnected.	Correctly connect the cord.
Panel switch fails to work.	Key lock is locked.	Change the key lock to the proper level. P.102

11. ERROR DISPLAY



Error is informed by means of the panel display, machine head mirror LED blink and control box buzzer.

Four different kinds of screens of the panel display screen appear due to the difference of the procedures.

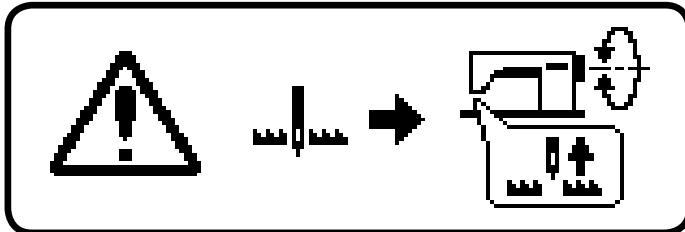

- 1) Error screen disappears when the operator removes the cause.

Example) The needle position is not in its UP position.
Make the needle position UP by turning the handwheel by hand.

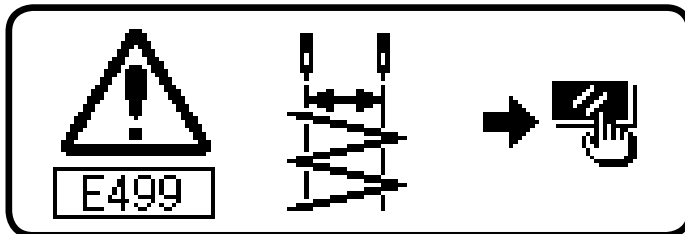

- 2) Press the reset switch, and remove the cause of error after erasing the error screen.

Example) E499 Max. zigzag width limitation error.
Press the reset switch.

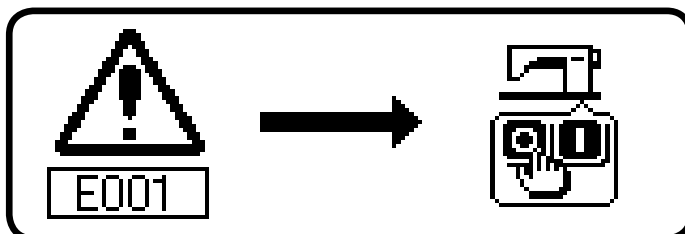

- 3) Remove the cause of error after turning OFF the power.

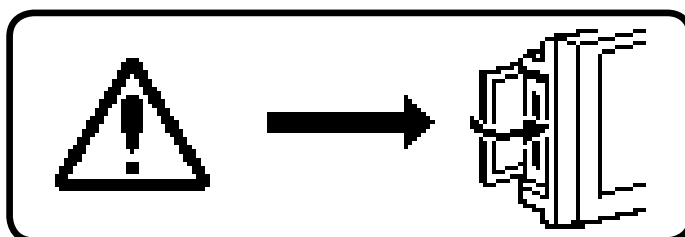

- 4) The screen shows that the media cover is open at the time of the communication mode.

⇒ Close the media cover.

11-1. Error code list (Error display in panel)



There are the following error codes in this device. These error codes interlock (or limit function) and inform the problem so that the problem is not enlarged when any problem is discovered. When you request our service, please confirm the error codes.

No.	Description of error detected	Cause	Item to be checked or corrective measure	Mirror LED flash	Pictograph display
—	UP position detection error when turning ON the power	• When needle position is not UP position at the time of turning ON the power.	• Set to UP position by turning handwheel by hand. • Connect synchronizer connector.	—	
—	Media cover open	• Lid of media slot is open.	• Close the lid.	—	
003	Disconnection of synchronizer connector	• When position detection signal is not inputted from the sewing machine head synchronizer. • When the synchronizer has broken.	• Check the synchronizer connector (CN30) for loose connection and disconnection. • Check whether the synchronizer cord has broken since the cord is caught in the machine head or the like.	—	
004	Synchronizer lower position sensor failure				
005	Synchronizer upper position sensor failure				
007	Overload of motor	• When the machine head is locked. • When sewing extra-heavy material beyond the guarantee of the machine head. • When the motor does not run.	• Check whether the thread has been entangled in the motor pulley. • Check the motor output connector (4P) for loose connection and disconnection.	—	
008	Machine head connector failure	• When the machine head connector is not properly read.	• Check the machine head connector (CN54) for loose connection and disconnection.	—	
011	Media not inserted	• Media is not inserted.	• Turn OFF the power.	—	
012	Read error	• Data read from media is not possible.	• Turn OFF the power.	—	
013	Write error	• Data write to media is not possible.	• Turn OFF the power.	—	
015	Format error	• Formatting cannot be performed.	• Turn OFF the power.	—	
016	External media capacity over	• Capacity of media is short.	• Turn OFF the power.	—	
019	File size over	• File is too big.	• Turn OFF the power.	—	
024	Pattern data size over	• Number of stitches and data amount which can be handled with device are over.	• Turn OFF the power.	—	
032	File compatibility error	• There is no file compatibility.	• Turn OFF the power.	—	
040	Travel limit over	• Sewing data has exceeded sewing possible area.	• Turn OFF the power.	—	
042	Operation error	• Operation of sewing data cannot be performed.	• Turn OFF the power.	—	
053	Execution of panel backup data initialization (Not error)	• When model code of panel does not agree with that of control box. When executing initialization operation with the panel.	• Turn OFF the power.	—	

No.	Description of error detected	Cause	Item to be checked or corrective measure	Mirror LED flash	Pictograph display
302	Fall detection switch failure	<ul style="list-style-type: none"> When fall detection switch is inputted in the state that the power is turned ON. 	<ul style="list-style-type: none"> Check whether the machine head is tilted without turning OFF the power switch (sewing machine operation is prohibited for safety sake). Check whether the fall detection switch cord is caught in the sewing machine or the like and has broken. Check whether the fall detection switch lever is caught in something. 	—	
487	Feed pitch error of condensation section	<ul style="list-style-type: none"> When feed pitch of condensation section exceeds the range of feed. 	<ul style="list-style-type: none"> Re-enter data after reset operation. Set the feed amount of condensation section within the range of limitation. 	7 times flash	
488	Reverse feed pitch error of normal sewing section	<ul style="list-style-type: none"> When reverse feed pitch of normal sewing section exceeds the range of feed. 	<ul style="list-style-type: none"> Re-enter data after reset operation. Set the reverse feed amount of normal sewing section within the range of limitation. 	7 times flash	
489	Normal feed pitch error of normal sewing section	<ul style="list-style-type: none"> When normal feed pitch of normal sewing section exceeds the range of feed. 	<ul style="list-style-type: none"> Re-enter data after reset operation. Set the normal feed amount of normal sewing section within the range of limitation. 	7 times flash	
490	Pattern setting error of continuous stitching and cycle stitching	<ul style="list-style-type: none"> When pattern No. is not set to continuous stitching. When the number of stitches of 1st step of continuous stitching is "0". When pattern No. is not set to cycle stitching. 	<ul style="list-style-type: none"> Re-enter data after reset operation. Set pattern No. and number of stitches. 	7 times flash	
491	Cycle stitching pattern error	<ul style="list-style-type: none"> When pattern to be used in cycle stitching becomes error. 	<ul style="list-style-type: none"> Re-enter data after reset operation. Correct data of pattern which becomes error. 	7 times flash	
492	Data deletion impossible	<ul style="list-style-type: none"> When data to be deleted is used in pattern sewing, continuous stitching or cycle stitching. 	<ul style="list-style-type: none"> Reset operation In case of deletion, release the use of pattern sewing, continuous stitching or cycle stitching used, and perform again deletion. 	—	
493	Condensation custom pattern width error	<ul style="list-style-type: none"> When zigzag width of condensation custom pattern is larger than max. zigzag width limitation. 	<ul style="list-style-type: none"> Re-enter data after reset operation. Set zigzag width of condensation custom pattern within max. zigzag width limitation. 	7 times flash	
498	Position of stitch base line error	<ul style="list-style-type: none"> When the set zigzag width is within max. zigzag width limitation, but zigzag position exceeds max. zigzag width limitation according to the position of stitch base line. 	<ul style="list-style-type: none"> Re-enter data after reset operation. Set the position of stitch base line within max. zigzag width limitation. When condensation custom is selected, check and correct the position of condensation. 	7 times flash	
499	Max. zigzag width error	<ul style="list-style-type: none"> When specified zigzag width is within max. zigzag width limitation, but zigzag position exceeds max. zigzag width limitation according to the position of stitch base line. 	<ul style="list-style-type: none"> Re-enter data after reset operation. Set the position of stitch base line within max. zigzag width limitation. 	7 times flash	
703	Connection of panel which is not supposed	<ul style="list-style-type: none"> When panel connected to the sewing machine is the kind which is not supposed. 	<ul style="list-style-type: none"> Turn OFF the power. Connect the proper panel. 	—	

No.	Description of error detected	Cause	Item to be checked or corrective measure	Mirror LED flash	Pictograph display
704	Inconsistency of system versions	<ul style="list-style-type: none"> When system versions are inconsistent. 	<ul style="list-style-type: none"> Turn OFF the power. Consist system versions with each other. 	—	
730	Encoder failure	<ul style="list-style-type: none"> When the motor signal is not properly inputted. 	<ul style="list-style-type: none"> Check the motor signal connector (CN38) for loose connection and disconnection. Check whether the motor signal cord has broken since the cord is caught in the machine head or the like broken since the cord is caught in the machine head or the like. 	—	
731	Motor hole sensor failure				
734	Reverse feed control lever sensor error	<ul style="list-style-type: none"> Abnormality of reverse feed control lever sensor detection 	<ul style="list-style-type: none"> Turn OFF the power. Disconnection of relay cable of reverse feed control lever sensor Trouble of reverse feed control lever sensor 	—	
810	Solenoid short-circuit	<ul style="list-style-type: none"> When the short-circuited solenoid is desired to be driven. 	<ul style="list-style-type: none"> Check whether the solenoid is short-circuited. 	—	
811	Overvoltage	<ul style="list-style-type: none"> When voltage upper than guaranteed one is inputted. When 200V is inputted for 100V setting. 	<ul style="list-style-type: none"> Check whether the applied power voltage is higher than the rated voltage + (plus) 10% or more. Check whether 100V/200V changeover connector is set by mistake. In the above cases, POWER circuit board has broken. 	—	
813	Low voltage	<ul style="list-style-type: none"> When voltage lower than guaranteed one is inputted. When 100V is inputted for 200V setting. 	<ul style="list-style-type: none"> Check whether the voltage is lower than the rated voltage - (minus) 10% or less. Check whether 100V/200V changeover connector is set by mistake. 	—	
907	Zigzag drive origin error	<ul style="list-style-type: none"> Origin sensor of zigzag drive motor is not detected. 	<ul style="list-style-type: none"> Turn OFF the power. Trouble of origin sensor of zigzag drive motor Disconnection of relay cable of zigzag drive motor Trouble of zigzag drive circuit 	—	
915	Operation panel transmission failure	<ul style="list-style-type: none"> Disconnection of operation panel cord Operation panel has broken. 	<ul style="list-style-type: none"> Check the operation panel connector (CN3) for loose connection and disconnection. Check whether the operation panel cord has broken since the cord is caught in the machine head or the like. 	4 times flash	
919	Overheat error	<ul style="list-style-type: none"> When temperature of inside of electrical box has abnormally risen. 	<ul style="list-style-type: none"> Turn OFF the power. Cleaning of fan filter Removal of cause of temperature rise of electrical box 	—	
924	Motor driver failure	<ul style="list-style-type: none"> Motor driver has broken. 		—	
939	Feed drive origin error	<ul style="list-style-type: none"> Origin sensor of feed drive motor is not detected. 	<ul style="list-style-type: none"> Turn OFF the power. Trouble of origin sensor of feed drive motor Disconnection of relay cable of feed drive motor Trouble of feed drive circuit. 	—	

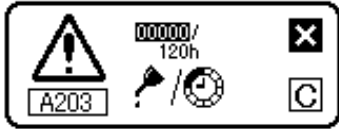
■ Warning list

No	Contents and display of warning	Corrective measure	Remarks
A201	Replacement of needle warning 	<ul style="list-style-type: none"> • Press X to close warning screen, and perform replacement of needle. Then clear the value in the clear screen. • Press C to clear the value, and perform replacement of needle. 	Refer to “Sewing management information, p.103.
A202	Cleaning warning 	<ul style="list-style-type: none"> • Press X to close warning screen, and perform cleaning. Then clear the value in the clear screen. • Press C to clear the value, and perform cleaning. 	Refer to “Sewing management information, p.103.
A203	Replacement of oil warning 	<ul style="list-style-type: none"> • Press X to close warning screen, and perform replacement of oil. Then clear the value in the clear screen. • Press C to clear the value and perform replacement of oil. 	Refer to “Sewing management information, p.103.

12. TROUBLES AND CORRECTIVE MEASURES

Phenomenon	Cause	Corrective measures	See page
Thread breakage	① When the thread gets entangled in the thread take-up lever.	Remove the entanglement.	21
	② When the needle thread is threaded in a wrong way.	Thread it correctly.	21
	③ When the thread gets entangled in the sewing hook.	Remove the entanglement.	131
	④ When the needle thread is excessively tight or loose.	Adjust the thread tension.	123
	⑤ When the needle thread slips out of the rotary disc.	Increase the tension of the pretension disk.	
	⑥ When the tension of the thread take-up spring is excessively high or low.	Adjust the tension of the take-up spring.	123 123
	⑦ When the stroke of the thread take-up spring is excessively large or small.	Adjust the stroke of the take-up spring. (8 to 12 mm)	123
	⑧ When the timing of the sewing hook and the needle is not matched.	Adjust the timing.	131
	⑨ When there is a scratch on the thread path of hook, bobbin case, thread take-up lever or any other part.	Remove such a scratch or replace the component.	130, 131
	⑩ When the thread is not suitable. a. The quality of the thread is poor. b. The thread is too thick for the needle. c. The thread is broken by heat.	Use a thread of good quality. Use a suitable thread or needle. Use JUKI Silicone Oil Lubricant unit.	
	⑪ When the stitch is skipped.	Refer to the following paragraphs, Stitch skipping.	
Stitch skipping	① When the needle is inserted in a wrong way. a. The needle is not entirely inserted into the needle bar. b. The needle eye is not facing straight to the operator. c. The needle is facing backwards.	Fully insert the needle. Let the needle eye face straight to the operator. Let the long groove on the needle face to the operator.	19 19 19
	② When the needle itself is not suitable. a. The needle is bent. b. The quality of the needle is not good. c. The needle is too thin for the thread. d. Blunt needle is used.	Replace it with a new needle. Use a needle of good quality. Use a suitable needle or thread. Replace it with a new needle.	19
	③ When the hook blade point is not sharp enough or damaged.	Resharpen the hook or replace it.	130, 131
	④ When the timing of the sewing hook and the needle is not matched.	Adjust the timing properly.	131
	⑤ When the height of the needle bar is not correct.	Adjust the height of the needle bar.	131
	⑥ When the clearance between the needle and the sewing hook is too great.	Adjust the clearance.	131
	⑦ When the needle thread slips out of the rotary disc. (For optional auxiliary thread take-up lever type only)	Adjust the position of the auxiliary thread take-up lever properly.	133
Loose stitch	① When the needle thread tension is too low.	Increase the needle thread tension.	123
	② When the tension of the thread take-up spring is too low.	Increase the tension of the spring.	123
	③ When the tension of the bobbin thread is too high.	Decrease the bobbin thread tension.	123
	④ When the timing of the sewing hook and the needle is not matched.	Adjust the timing correctly.	131
	⑤ When the thread is too thick for the needle.	Use a suitable needle or thread.	
	⑥ When the thread slips out of the rotary disc.	Increase the tension of the pretension disk.	123
	⑦ When the count of thread is too high.	Replace the thread tension controller with double-disk type thread tension controller (Part No. 40017095).	123
Irregular stitch tightness	① When the bobbin thread tension is too low.	Increase the bobbin thread tension.	123
	② When the bobbin thread is not wound correctly.	Wind up the bobbin thread evenly.	19
	③ When there is a scratch on the thread path of the sewing hook, bobbin case, thread take-up lever or any other parts.	Remove such a scratch or replace the component.	
Needle breakage	① When the needle is bent.	Replace it with a new needle.	
	② When the quality of the needle is not good.	Use a needle of good quality.	
	③ When the needle is not entirely inserted into the needle bar.	Insert the needle into the needle bar as far as it will go.	19
	④ When the needle hits the sewing hook.	Adjust the timing and clearance between the needle and the sewing hook and also the position of the needle guard.	131
	⑤ The needle is too thin for the sewing material and thread.	Replace a suitable needle.	
	⑥ The needle hole in the throat plate is too narrow.		
	⑦ The needle hits against the throat plate.		
	⑧ The needle hits against the presser foot.		

Bird's nest prevention (CB) type

Phenomenon	Cause	Corrective measure	See page
Needle thread clamp failure	① Improper wiper position.	Adjust the wiper to the proper position.	134
	② Air pressure drop.	Set the air pressure to 0.6Mpa.	16
	③ Dust bag becomes excessively filled with waste thread.	Remove waste thread from the dust bag.	137
	④ Thread trimmer or wiper operates when needle does not enter the cloth.	Operate thread trimmer or wiper on the cloth.	135
	⑤ Needle thread length is too short. Thread does not reach the clamp head.	Perform pre-tension adjustment and lengthen needle thread. (Adjust the length from the clamp head to approximately 20 to 35 mm.)	123
	⑥ Uneven length of left and right needle threads (Thread which is not stretched such as cotton thread or the like is used.)	Change the kind of thread.	
Bobbin thread at the start of sewing is drawn up on the cloth.	Bobbin thread is taken up on the cloth by needle thread at 1st stitch at the start of sewing since needle thread remaining amount after completion of needle thread clamp is small.	Step 1 : Increase the drawing amount of needle thread and increase needle thread remaining amount at the start of sewing.	133
		Step 2 : Make tension release SOL (solenoid) actuate at the start of sewing to perform tension release and increase the thread remaining amount. (Input the number of stitches of thread release at the start of sewing with function setting No.100.)	116
		Step 3 : Make the thread drawing device actuate again after completion of needle thread clamp to perform tension release and increase the thread remaining amount. (Set function setting No.18 to 2.)	113
		Step 4 : Make all step items (1 + 2 + 3) function.	113, 116
Knife to cut needle thread is dull.	① Worn-out of needle thread cutting knife.	Replace the knife with a new one.	135
	② Improper installing position of the knife.	Adjust the position to the proper one.	135
	③ Thick thread is used.	Change the thread count.	134
	④ Start of sewing is set to the reverse feed.	Change to the normal feed.	134
Interference of wiper with needle	① Improper UP stop position.	Adjust the UP stop position.	132
	② Improper wiper locus.	Re-adjust the locus of the wiper.	134
	③ Improper wiper position.	Re-adjust the position of the wiper.	134
	④ Length of needle tip is longer than that of the standard delivery needle.	Re-adjust the position of the wiper.	134
Needle thread is cut during sewing.	① Needle thread enters the needle thread cutting groove of the presser.	Replace the presser with the general presser (presser without knife).	134

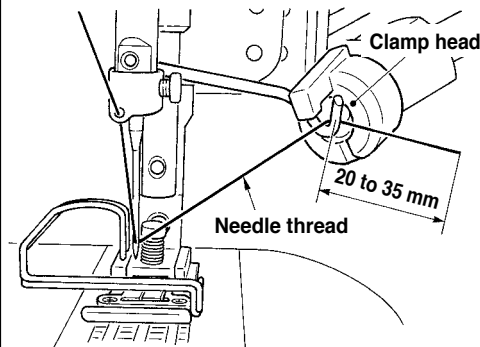

[Power voltage changeover procedure (power voltage setting procedure)]



WARNING :

To prevent personal injuries caused by electric shock hazards or abrupt start of the sewing machine, carry out the work after turning OFF the power switch and a lapse of 5 minutes or more. To prevent accidents caused by unaccustomed work or electric shock, request the electric expert or engineer of our dealers when adjusting the electrical components.

It is adaptable to the voltage of single phase 100V to 120V/3-phase 200V to 240V by changing the voltage changeover connector mounted on FLT p.c.b.

(Caution) When the changing procedure is wrong, the control box will be broken. So, be very careful.

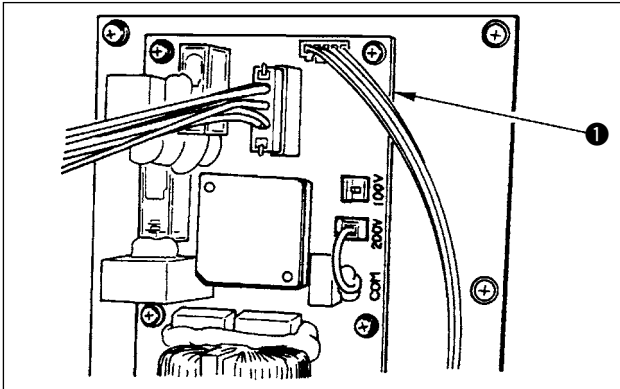

Changing procedure of the changeover connector

1. Turn OFF the power source with the power switch after confirming that the sewing machine has stopped.
2. Draw out the power cord from the power plug socket after confirming that the power switch is turned OFF. Then wait for five minutes or more.
3. Remove the front cover.
4. Remove four screws fixing the rear cover of the control box and slowly open the rear cover.

A. In case of using with 3-phase 200V to 240V

• Changing the changeover connector

Connect to 200V the 100/200V changeover connector of FLT p.c.b. ❶ located on the upper side of the right side face as observed from the rear cover side.

• Connect the crimp style terminal of AC input cord to the power plug as shown in the figure.

B. In case of using with single phase 100V to 120V

• Changing the changeover connector

Connect to 100V the 100/200V changeover connector of FLT p.c.b. ❶ located on the upper side of the right side face as observed from the rear cover side.

• Connect the crimp style terminal of AC input cord to the power plug as shown in the figure.

(Caution) Securely perform the insulation treatment to the black terminal which is not used with insulation tape or the like.

(When the insulation is insufficient, there is a danger of electric shock or leakage current.)

C. In case of using with single phase 200V to 240V

• Changing the changeover connector

Connect to 200V the 100/200V changeover connector of FLT p.c.b. ❶ located on the upper side of the right side face as observed from the rear cover side.

• Connect the crimp style terminal of AC input cord to the power plug as shown in the figure.

(Caution) Securely perform the insulation treatment to the black terminal which is not used with insulation tape or the like.

(When the insulation is insufficient, there is a danger of electric shock or leakage current.)

5. Check that the change has been performed without fail before closing the rear cover.
6. Be careful that the cord is not pinched between the rear cover and the control box main unit. Close the rear cover while pressing the lower side of rear cover, and tighten four screws.

