

JUKI®

SINGLE-NEEDLE LOCKSTITCH UPPER AND LOWER FEED
INDUSTRIAL SEWING MACHINE

MODEL

LY2-3300-B0B

INSTRUCTION MANUAL

INTRODUCTION

Thank you very much for purchasing industrial sewing machine.

Please read this instruction manual before operating the sewing machine. Please read also “Safety Manual”, “Instruction manual for LIMISERVO” and operate the sewing machine correctly and safely.

PRECAUTION BEFORE STARTING OPERATION

1 Safety Precautions

1. When turning the power on, keep your hands and fingers away from the area around/under the needle and the area around the pulley.
2. The power must be turned off when the machine is not used, or when the operator leaves his/her seat.
3. The power must be turned off before tilting the machine head, installing or removing the “V” belt, adjusting the machine, or replacing parts.
4. Avoid placing fingers, hairs, obstacles, etc. near the pulley, “V” belt, bobbin winder wheel, or motor when the machine is in operation. Injury could result.
5. Don't put fingers into the thread take-up lever cover, around/under the needle, or pulley when the machine is in operation.
6. If the belt cover, the finger guard, and/or the eye guard are installed, don't operate the machine without these safety devices.

2 Precaution before Starting Operation

1. If the machine's oil pan has an oil sump, never operate the machine without filling oil in it.
2. If the machine is lubricated by a drop oiler, never operate the machine without lubricating.
3. When a new sewing machine is operated, verify the rotational direction of the pulley with the power on.
(The pulley should rotate counterclockwise when viewed from the pulley.)
4. Verify voltage and (single or three) phase indicated on the nameplate of the motor.

3 Precaution for Operating Conditions

1. Avoid using the machine at abnormally high temperature (35°C or higher) or low temperature (5°C or lower). Otherwise, machine failure may result.
2. Avoid using the machine in dusty conditions.
3. Avoid using the machine in conditions filled with a lot of electric noises such as high-frequency welders.

CONTENTS

| | |
|---|---|
| USAGE PRECAUTION | 1 |
| 1 Lubrication | 1 |
| 2 Adjustment of lubrication to the rotating hook | 1 |
| 3 Periodical cleaning | 2 |
| 4 Installation of the belt cover | 2 |
| 5 Precaution on operation | 2 |
| HOW TO USE | 3 |
| 1 Installation of the needle | 3 |
| 2 Winding of the bobbin thread | 3 |
| 3 Threading of the needle thread | 4 |
| 4 Adjustment of feed (stitch) length and backstitch | 4 |
| 5 Balance of threads tension | 4 |
| 6 Adjustment of the needle thread tension | 4 |
| 7 Adjustment of the bobbin thread tension | 5 |
| 8 Adjustment of the presser foot pressure | 5 |
| 9 Adjustment of the feed dog height | 5 |
| 10 Adjustment of the feed foot and the presser foot | 6 |
| 11 To handle thread at the start of sewing | 7 |
| SPECIFICATIONS | 8 |

USAGE PRECAUTION

1 Lubrication

- Pour oil up to the arrow position before starting operation.

 ...About 3 cc

 ...5, 6 drops

 ...1, 2 drops

For oil, use "Pulley SF oil" specified by our company.

※ Refer

Pulley SF oil : Specific gravity (15°C) = 0.86 (g/cm³)
: Viscosity (40°C) = 18.0 (mm²/s)

- When a new sewing machine is used for the first time, or sewing machine left out of use for considerably long time is used again, replenish a suitable amount of oil to the portions indicated by arrows in the below figure.

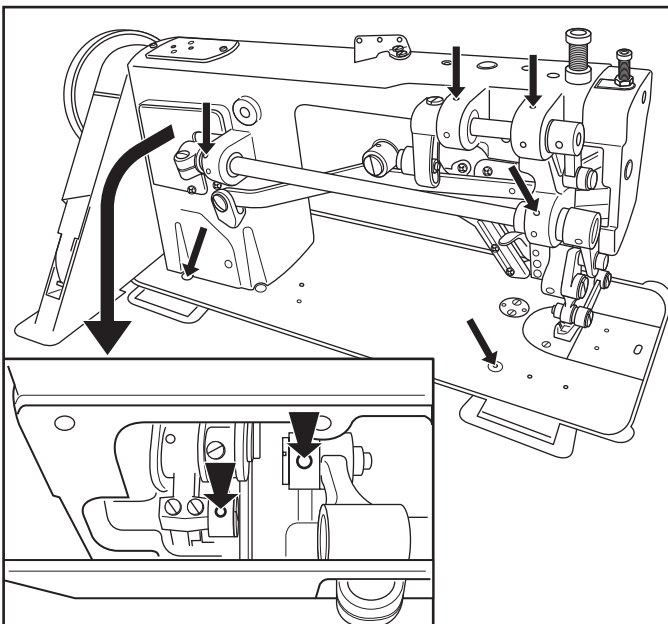
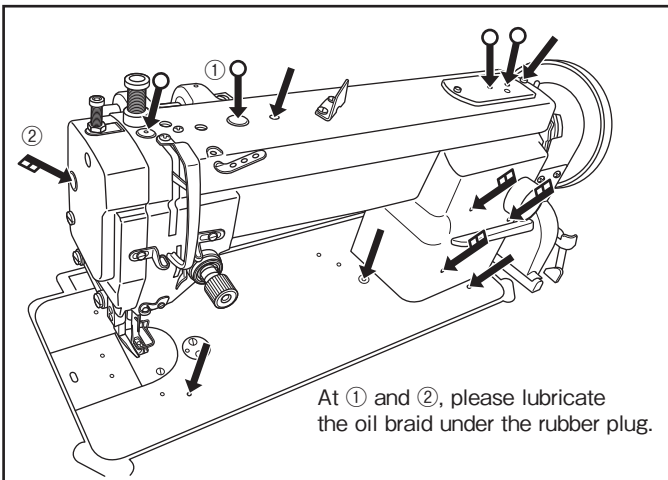

Supply the oil to the tank of the bed

Fill oil up to the line when the oil would come bottom level.

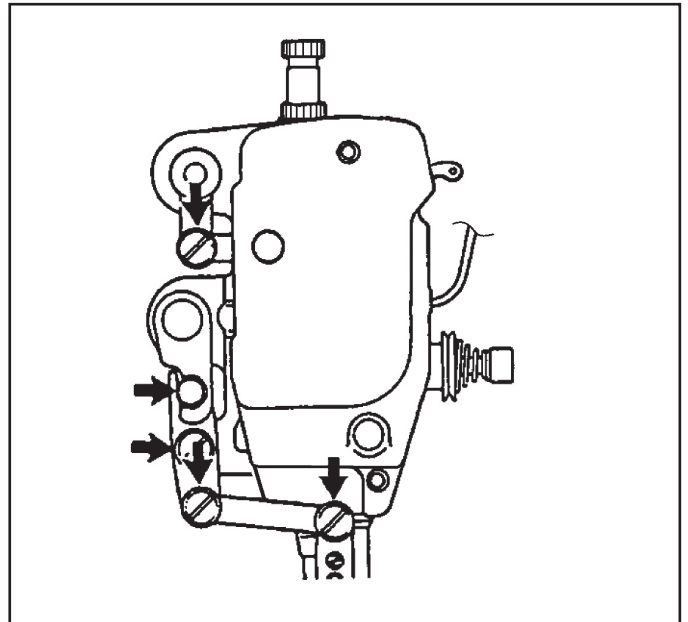
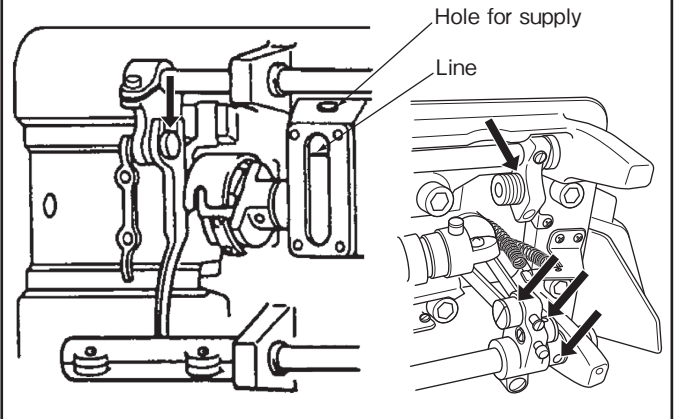

2 Adjustment of lubrication to the rotating hook

Adjust the lubrication amount of the rotating hook by turning the screw (A).

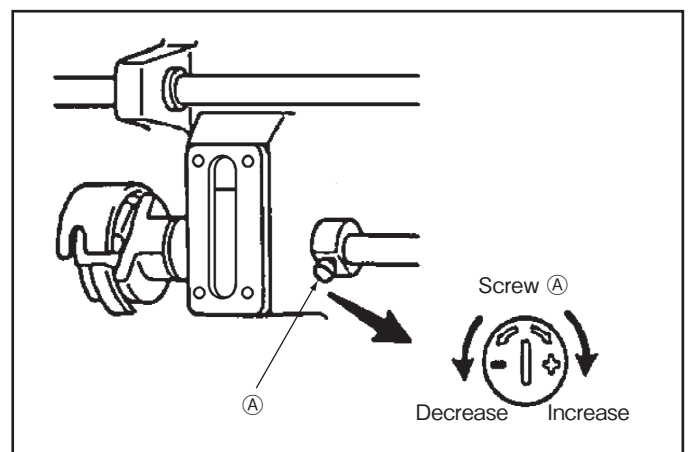

USAGE PRECAUTION

3 Periodical cleaning

1. Machine

- Remove the throat plate and clean the feed dog. Reassembly should be done by screwing in the screw 2-3 rotations by hand at first, then tightening them evenly using a long-shafted screwdriver.

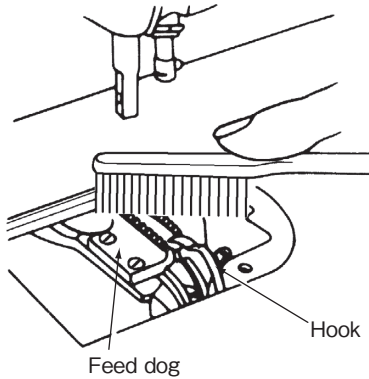

- Lean the machine head and clean the hook and remove any dust and /or lint inside the bobbin case.

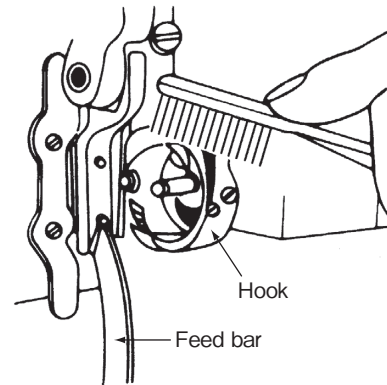

2. Motor

Remove dust from the motor filter every one or two months. (Continued operation with the filter clogged with lint or dust may overheat the motor.)

3. Control Box

Remove dust from the connector. (If the connector is covered with dust, the machine might malfunction.)

4 Installation of the belt cover

1. Install the belt cover on the machine side for safety. Refer to the provided instruction document contained in the same package.
2. Install the belt cover on the motor side for safety.

5 Precaution on operation

- (1) When the power is turned on or off, keep foot away from the pedal.
- (2) It should be noted that the brake may not work when the power is interrupted or power failure occurs during sewing machine operation.
- (3) Since dust in the control box might cause malfunction or control troubles, be sure to keep the control box cover close during operation.
- (4) Do not apply a multimeter to the control circuit for checking, otherwise voltage of multimeter might damage semiconductor components in the circuit.

HOW TO USE

1 Installation of the needle

Note: Before installing the needles, be sure to turn off the power.

Insert the needle upto the bottom of needle clamp and tighten the screw keeping the long groove side facing to the left.

Insufficient insertion

Needle distorted

Note : If thread snapping occurs during reverse sewing with polyester threads, it may be avoided by fitting the needle with the long groove shifted to the front side. Normally, avoid fitting the needle with the groove facing backward.

Both needles DP × 17 and DB × 1 can be used. Use the timing marks as shown in the figure.

Timing mark for DB×1

Timing mark for DP×17

Needle bar

2 Winding of the bobbin thread

Note: When bobbin thread is wound, keep the presser foot lifted.

- Adjustment**
- **Tension of wound thread** Slack winding is recommended for polyester thread and nylon thread.
 - **Conically wound thread** Move the thread guide toward smaller diameter of wound thread layer.
 - **Amount of wound thread** Loosen the winding amount adjustment screw to decrease thread winding amount and tighten the screw to increase thread winding amount.

Thread guide

Winding tension adjustment nut

Winding amount adjustment screw

Even winding amount of 80% of full capacity

HOW TO USE

3 Threading of the needle thread

With the thread take-up lever located at the upper most position, pass the needle thread in the order shown in the following figure.

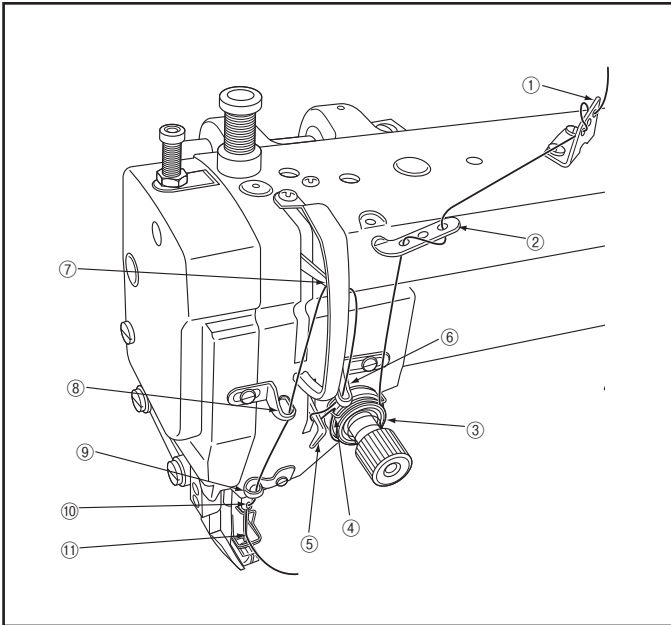

4 Adjustment of feed (stitch) length and backstitch

- Adjustment of feed (stitch) length... Adjust feed length by turning the feed length setting dial while depressing the reverse sewing lever.
- Backstitch... Direction of stitching can be reversed by depressing the reverse sewing lever.

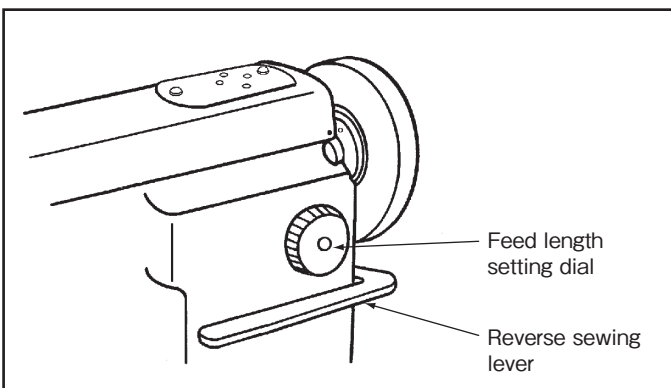

5 Balance of threads tension

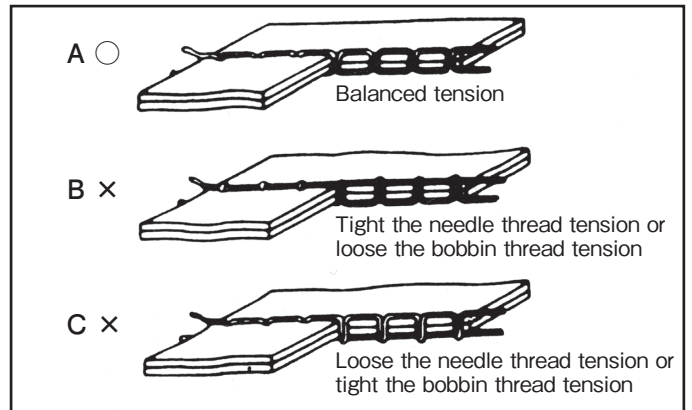

6 Adjustment of the needle thread tension

- The needle thread tension should be adjusted on the basis of the bobbin thread tension.
- Adjust the needle thread tension by turning the thread tension nut.

The needle thread tension can be also adjusted by changing intensity and movable range of the thread take-up spring in case of sewing the special fabric and thread.

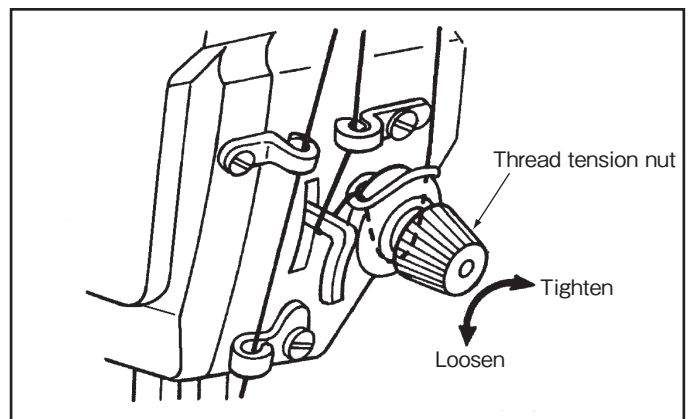

HOW TO USE

7 Adjustment of the bobbin thread tension

1. The bobbin thread tension can be adjusted by turning the screw (A).

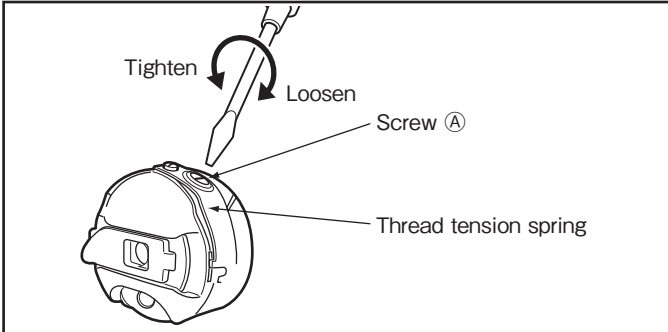

8 Adjustment of the presser foot pressure

1. Adjust the presser foot pressure according to the fabric by turning the pressure adjusting screw.
2. Pressure on the both the presser foot and the feed foot can be adjusted. (The adjusting screw position is factory-adjusted as shown in the figure.)
3. Sewing pressure should be adjusted to the minimum required strength.

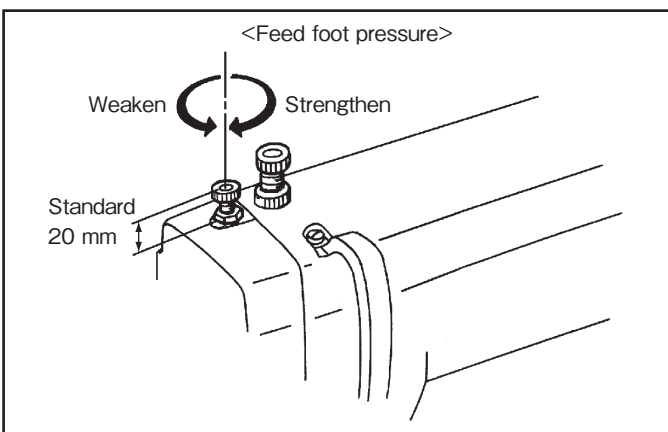
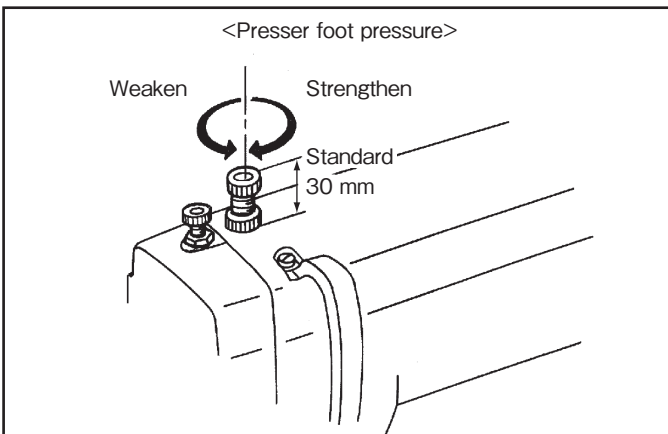

9 Adjustment of the feed dog height

1. Turn the pulley and stop it at the position where the feed lifting rock shaft crank (right) swings to the innermost position.
2. Loosen the screw (A).
Note: Be careful not to move the feed lifting rock shaft crank (right) in the lateral direction.
3. Adjust the feed dog height by swinging the feed lifting rock shaft crank (left) and moving the feed bar.
4. After adjusting, fully tighten the screw (A).

The feed dog height is factory-adjusted to 1.0 mm.

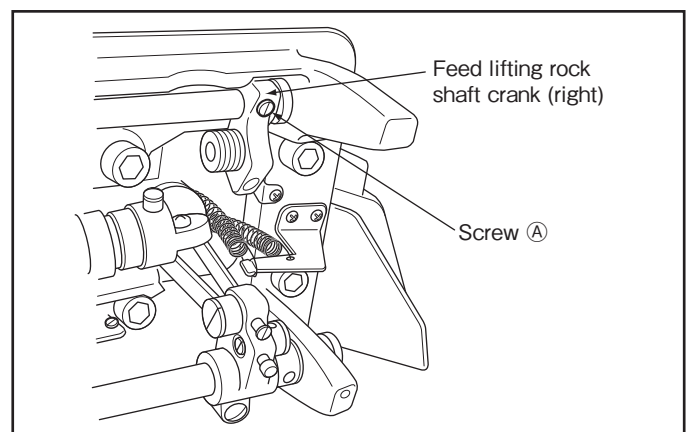
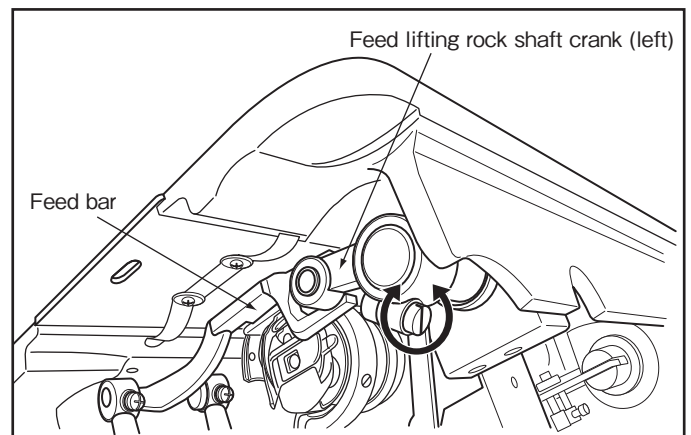
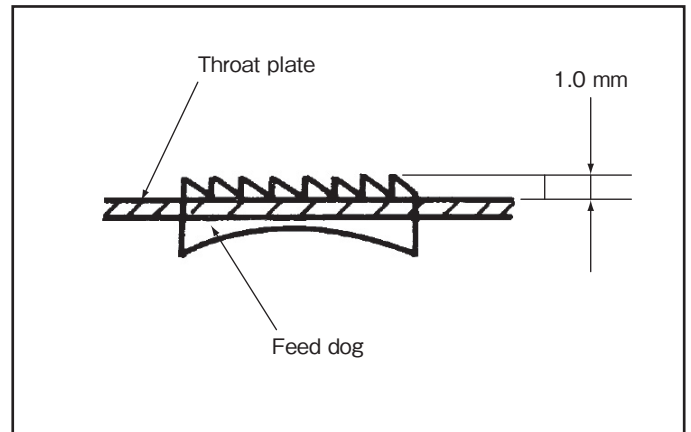

HOW TO USE

10 Adjustment of the feed foot and the presser foot

1. To change the balance of the alternating movements between the feed foot and presser foot

(1) For example, to increase the rise of the feed foot, and decrease the rise of the presser foot.

- ① Turn the pulley until the presser foot is slightly raised from the throat plate.
- ② Loosen the set screw **A** (on the right side) located on the feed lifting rock shaft crank (right).
- ③ The built-in spring pulls down the presser foot until it makes contact with the throat plate. Then, tighten the set screw **A**.
- ④ This completes the adjustment, i.e., the protrusion of the presser foot has been decreased by a set distance. And, the vertical motion of the feed foot has been increased by that same distance.

(2) As a contrary case (1), to decrease the rise of the feed foot, and increase the rise of the presser foot. First, turn the pulley until the feed foot is slightly raised from the throat plate. Next, loosen the screw **A**. Finally, tighten the screw **A** again.

This decreases the rise of the feed foot.

2. Adjustment of the movement height of the presser foot and feed foot

Note: When sewing a thin fabric, the up and down movement should be adjusted at minimum.

- To adjust, loosen the screw, and shift the position of crank rod boss.

Upward → The up and down movement will increase. (Max. 5 mm)

Downward → The up and down movement will decrease. (Min. 2 mm)

3. A gap between the feed foot and the presser foot

Note: At the condition the stitch length is at max., the min. gap between the feed foot and the presser foot is adjusted to be 5 mm as standard.

- Loosen the screw **A**, then turn the feed driving shaft, so that the gap **B** can be adjusted.

After adjusting, fully tighten the screw **A**.

4. Proper timing between the upper and lower feed

Note: Although the upper feed amount (feed foot) adjust the lower feed amount (feed dog) are adjusted by 1:1, please adjust the upper feed amount increasingly or decreasingly, according to the material to be sewn.

- To adjust, loosen the nut and shift the square block up and down.

Upward → Feeding amount will decrease

Downward → Feeding amount will increase

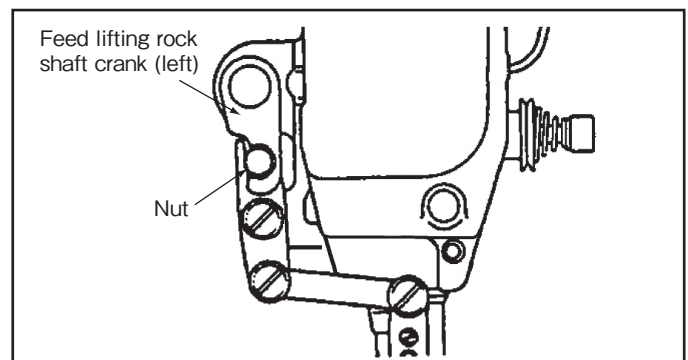
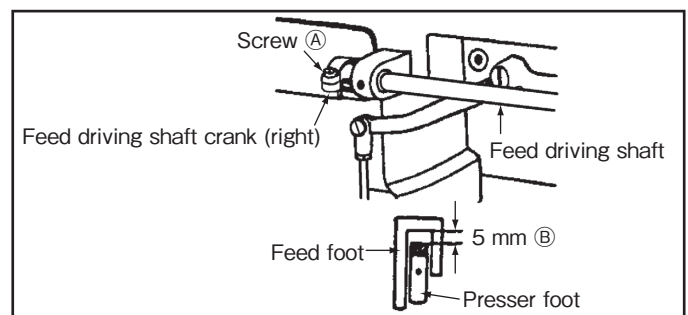
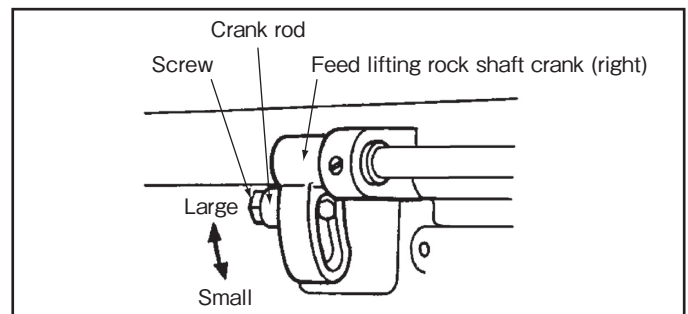
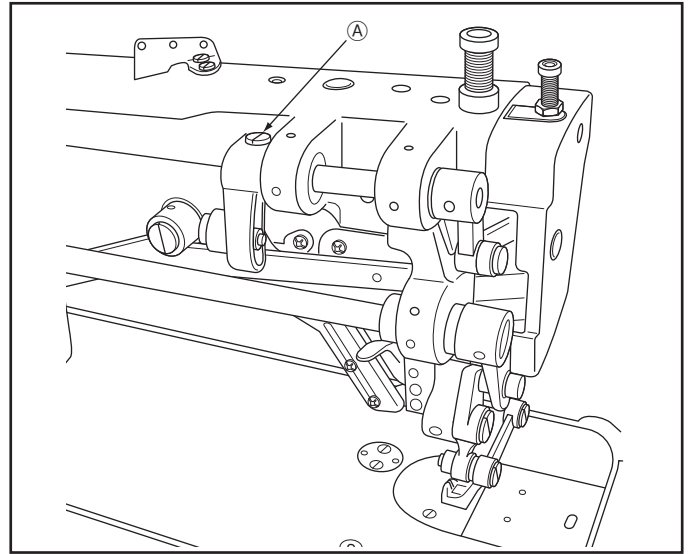

HOW TO USE

11 To handle thread at the start of sewing

1. In the case of open sewing:

When the needle thread is not held by the presser foot during sewing, the end of the needle thread is stitched onto the reverse side of the cloth, thus enhancing a sewing finish. Slowly start to take up a few stitches at the beginning so as to prevent the needle thread from being off out of the needle.

2. When the needle thread is held by the presser foot:

The end of the needle thread remains on the surface of the cloth.

To stitch in this way, it is preferable to pull out the sewn fabric to the other side of the presser foot at the end of sewing.

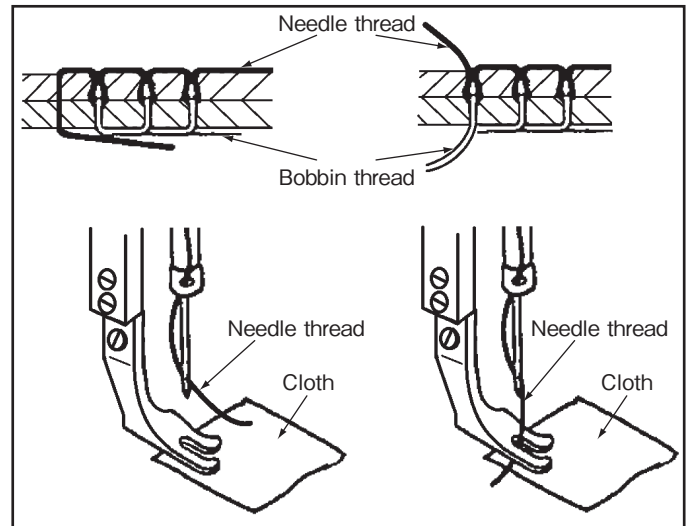

SPECIFICATIONS

LY2-3300-B0B Specifications

| | | |
|----------------------------------|-------|--|
| Specifications | Model | LY2-3300-B0B |
| Application | | Heavy material |
| Max. sewing speed (rpm) | | 2,000 |
| Stitch length (mm) | | 0 to 8 |
| Needle bar stroke (mm) | | 35.0 |
| Thread take-up lever stroke (mm) | | 73.0 |
| Alternating movement (mm) | | 2.0 to 5.0 (feed foot) |
| Feed dog height (mm) | | 1.0 |
| Presser foot stroke (mm) | Hand | 6.0 |
| | Knee | 13.0 |
| Needle | | DP × 17 #22 (DB × 1 #22) |
| Hook (vertical rotating hook) | | Large |
| Lubrication system | | Manual lubrication (The hook is supplied with oil automatically from the tank) |
| Bed dimensions (mm) | | 475 × 178 |

Note: ● The bobbin should be of high quality free from deformation.

● Some materials and/or sewing conditions may require specifications other than those listed above.

● These specifications are subject to change for machine improvement.

JUKI CORPORATION

Printed in Japan