

ENGLISH

**LU-2810-6, 2860-6
INSTRUCTION MANUAL**

CONTENTS

1. SPECIFICATIONS.....	1
2. INSTALLATION.....	1
3. INSTALLING THE BELT COVER AND THE BELT	2
4. ADJUSTING THE BELT TENSION.....	3
5. INSTALLING THE SYNCHRONIZER	3
6. ADJUSTING THE SYNCHRONIZER.....	4
7. INSTALLING THE OIL SHIELD	6
8. PNEUMATIC COMPONENTS.....	6
9. WIRING THE MACHINE HEAD	8
10. AIR PIPING AND MACHINE-HEAD WIRING	11
11. SEWING SPEED TABLE	12



CAUTION

This Instruction Manual for the LU-2810-6/-2860-6) only describes their differences from the standard models (LU-2810/-2810-7, LU-2860/-2860-7).

For safety-related information, carefully read and fully understand "Safety precautions" described in the Instruction Manual for the standard models before using your sewing machine.

1. SPECIFICATIONS

Model	LU-2810-6 (1-needle sewing machine with a thread trimmer and V-belt)	LU-2860-6 (2-needle sewing machine with a thread trimmer and V-belt)
Sewing speed	Max. 3,000 sti/min	Max. 2,700 sti/min
	Refer to " 11. SEWING SPEED TABLE " p.12.	
Stitch length (max.)	Normal feed : 9 mm Reverse feed : 9 mm	
Needle	GROZ-BECKERT 135 x 17 (Nm 125 to Nm 180) (Standard : Nm 160)	
Thread	#30 to #5 (US : #46 to #138, Europe : 20/3 to 60/3)	
Hook	Vertical-axis 2.0-fold capacity hook	
Lift of presser foot	Hand lifter lever : 10 mm By knee lifter, Auto-lifter: 20 mm	
Lubricating oil	JUKI New Defrix Oil No.1 or JUKI MACHINE OIL #7	
Noise * 1	<ul style="list-style-type: none"> - Equivalent continuous emission sound pressure level (L_{pA}) at the workstation: A-weighted value of 83.0 dB; (Includes $K_{pA} = 2.5$ dB); according to ISO 10821- C.6.2 - ISO 11204 GR2 at 3,000 sti/min. - Sound power level (L_{WA}); A-weighted value of 88.5 dB; (Includes $K_{WA} = 2.5$ dB); according to ISO 10821- C.6.2 - ISO 3744 GR2 at 3,000 sti/min. 	<ul style="list-style-type: none"> - Equivalent continuous emission sound pressure level (L_{pA}) at the workstation: A-weighted value of 83.0 dB; (Includes $K_{pA} = 2.5$ dB); according to ISO 10821- C.6.2 - ISO 11204 GR2 at 2,700 sti/min. - Sound power level (L_{WA}); A-weighted value of 88.5 dB; (Includes $K_{WA} = 2.5$ dB); according to ISO 10821- C.6.2 - ISO 3744 GR2 at 2,700 sti/min.

* 1 The aforementioned noise level is the one in the case of using the control box (SC-922) made by JUKI.

2. INSTALLATION

Refer to "**2. INSTALLATION**" p.2 in the Instruction Manual for the LU-2810, -2810-7, -2860 and -2860-7, packaged with the sewing machine, for how to install the sewing machine.

3. INSTALLING THE BELT COVER AND THE BELT



WARNING :

To protect against possible personal injury due to abrupt start of the machine, be sure to start the following work after turning the power off and ascertaining that the motor is at rest.

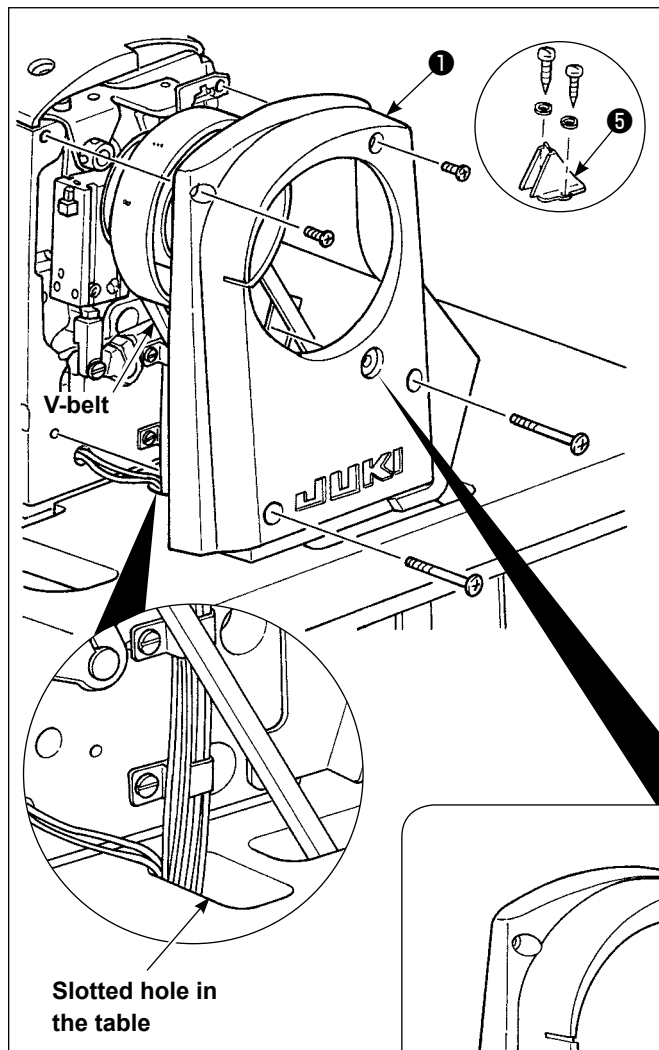

(Installation procedure)

- 1) Remove belt cover A ① .
- 2) Pass the 14P connector which puts cables together and the air tube through the slotted hole in the table.
- 3) Put the V-belt on the sewing machine pulley.
- 4) Adjust the belt tension.
- 5) Pass synchronizer support shaft ② and washer ③ through mounting hole in belt cover A ① and fix the synchronizer support shaft with washer ③ and nut ④ .
- 6) Mount belt cover A ① .
- 7) Install belt cover B ⑤ on the table.



Be sure to use the sewing machine with safety devices ① and ⑤ installed.

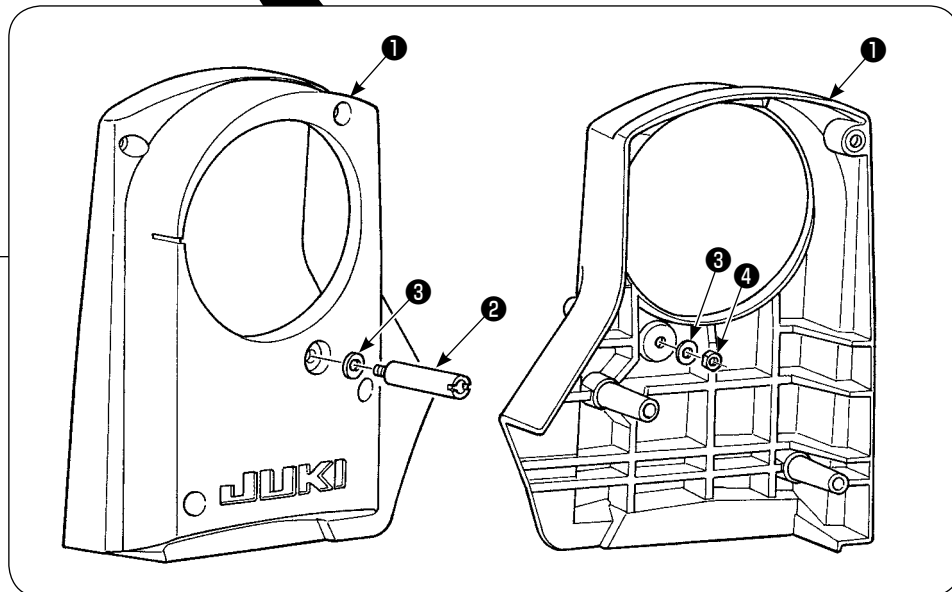

4. ADJUSTING THE BELT TENSION



WARNING :

To protect against possible personal injury due to abrupt start of the machine, be sure to start the following work after turning the power off and ascertaining that the motor is at rest.

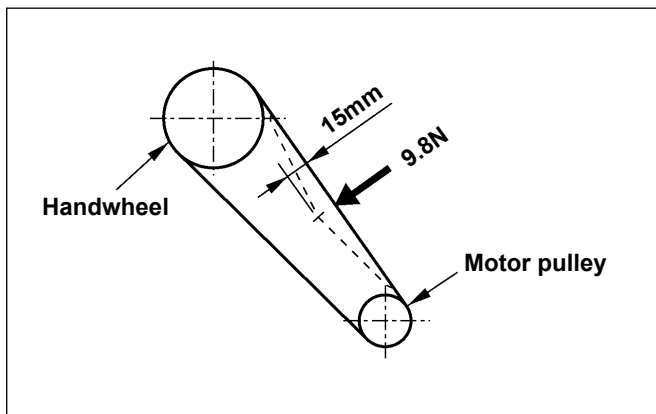

Adjust the belt tension with the height of the motor so that the belt sags 15 mm when the center of V belt is applied with a 9.8 N load.

5. INSTALLING THE SYNCHRONIZER



WARNING :

To protect against possible personal injury due to abrupt start of the machine, be sure to start the following work after turning the power off and ascertaining that the motor is at rest.

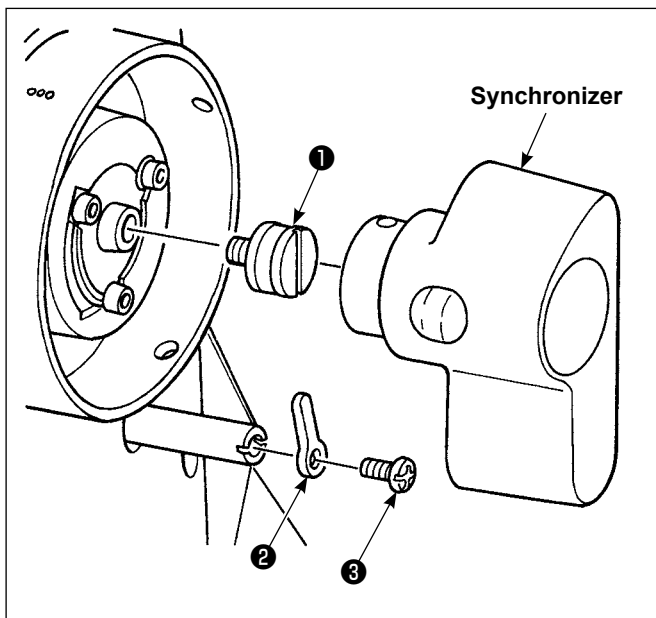

(Installation procedure)

- 1) Fix synchronizer flange ① on the end of the main shaft.
- 2) Fix the synchronizer on synchronizer flange ①.
- 3) Fix synchronizer support plate ② with setscrew ③ so as to prevent the synchronizer from rotating.



Be sure to remove the connector for the sewing machine for the sake of safety before checking the upper and lower positions of the synchronizer.

6. ADJUSTING THE SYNCHRONIZER



WARNING :

To protect against possible personal injury due to abrupt start of the machine, be sure to start the following work after turning the power off and ascertaining that the motor is at rest.

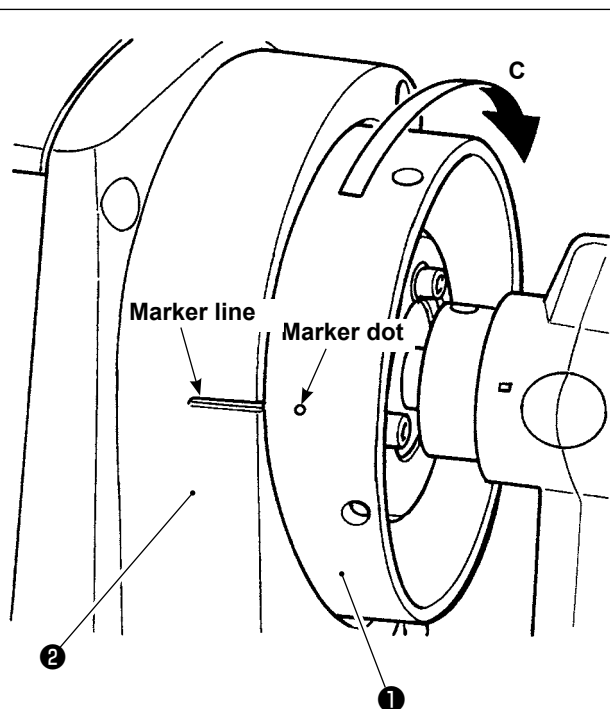

Adjust the upper stop position (needle-up stop position) so that the marker line on belt cover A (2) aligns with the marker dot (one) on handwheel (1) (70 ° position).

Adjust the lower stop position (needle-down stop position) so that the needle bar stops at the position where the needle bar goes up from the lower dead point (180 °) by approximately 13 mm (120 ° position). (The position which is reached by turning the handwheel from the lower end of the needle bar in the reverse direction of rotation of the main shaft (direction C))

Marker dot on the handwheel

Upper stop position
(one marker dot)
70 °

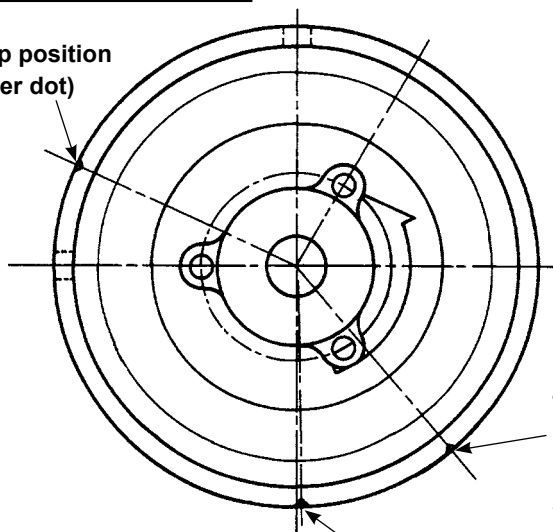

Thread trimming
cam alignment
(two marker dots)
275 °

Opener timing adjustment
(three marker dots)
314 °

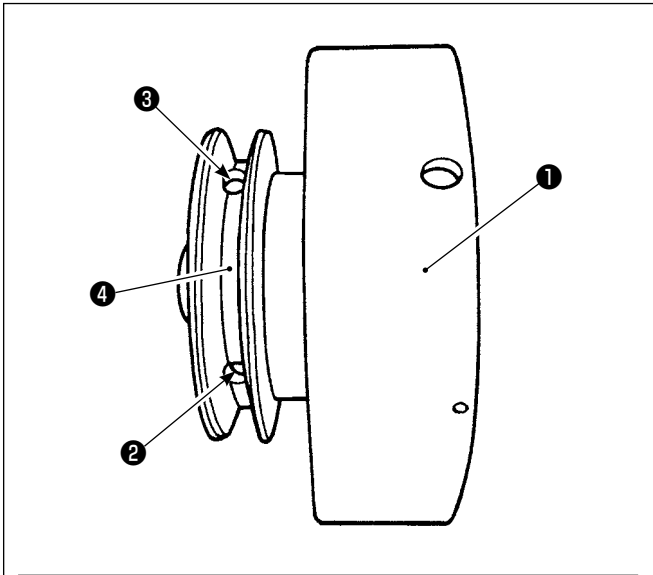

(How to remove the handwheel)

To remove handwheel ①, loosen screws ② and ③ and remove handwheel ① in such a state that it is assembled with handwheel A ④.



Do not remove only handwheel ① by loosening setscrew ⑤.

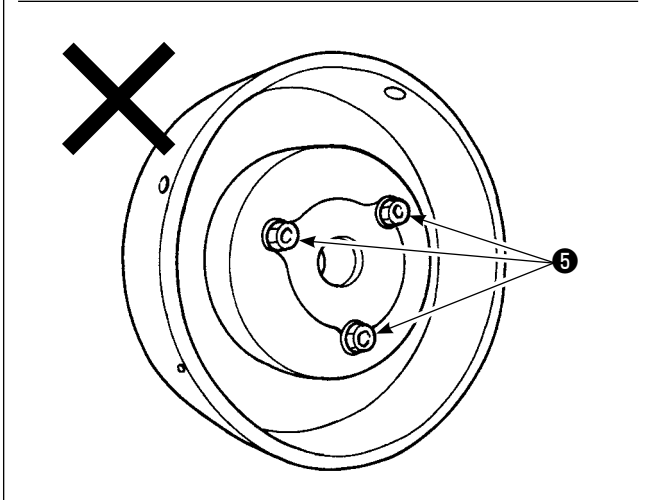

(How to assemble the handwheel)

Check to make sure that handwheel A ④ does not come in contact with cylinder ⑦ when screw ② of handwheel A ④ is brought to the position where it is aligned with the flat section of main shaft ⑥. Then, fix the handwheel on main shaft ⑥. At this time, main shaft ⑥ protrude from handwheel ① by approximately 7 mm.

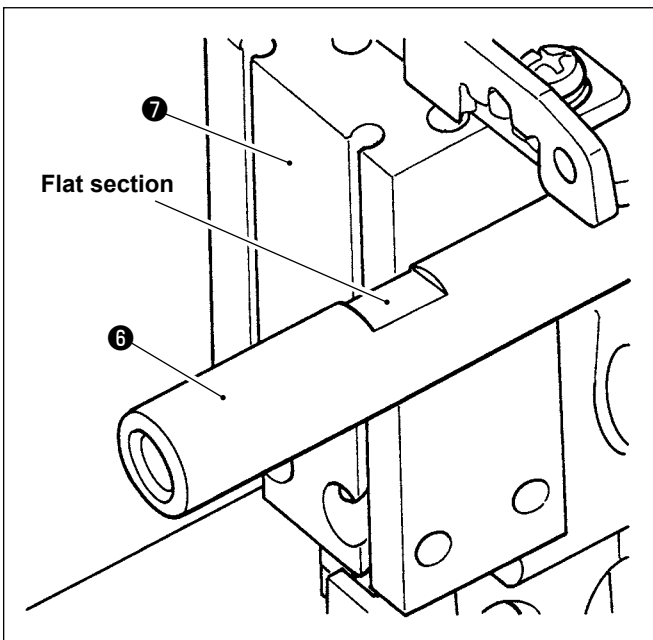

7. INSTALLING THE OIL SHIELD



WARNING :

To protect against possible personal injury due to abrupt start of the machine, be sure to start the following work after turning the power off and ascertaining that the motor is at rest.

LU-2810-6

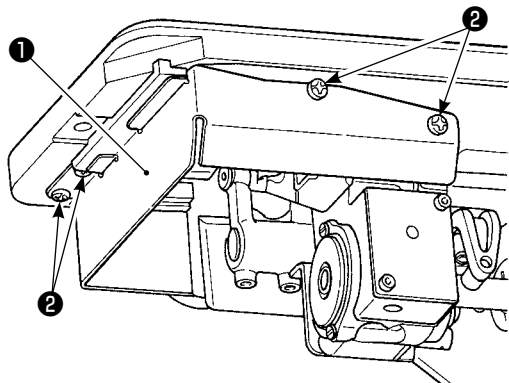

Install oil shield **1** , supplied with the unit, on the frame with screws **2** .

LU-2860-6

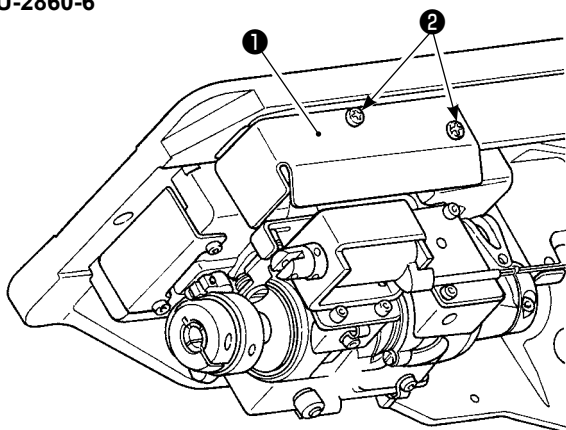

8. PNEUMATIC COMPONENTS



WARNING :

To protect against possible personal injury due to abrupt start of the machine, be sure to start the following work after turning the power off and ascertaining that the motor is at rest.

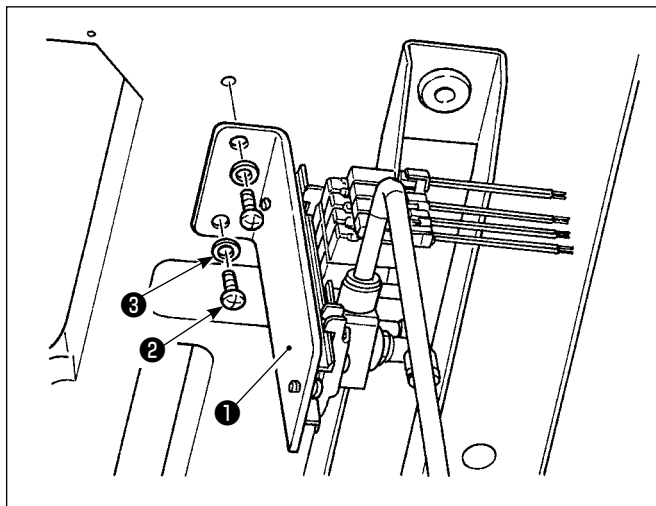

(1) Installing the solenoid valve mounting plate

Install solenoid valve mounting plate asm. **1** to the underside of the table with screw **2** and washer **3** supplied with the unit.

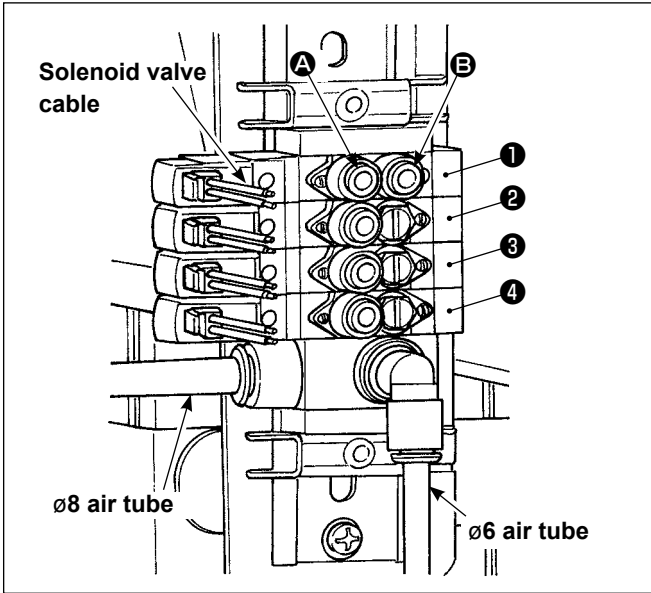

(2) Connecting the air tube and the solenoid valve cable

Connect the air tubes and the solenoid valve supplied with the unit to the locations shown below.

Solenoid valve	Tube number	Cable number
1 - B	1	CN155
1 - A	2	
2 - A	4	CN151
3 - A	6	CN153
4 - A	8	CN152

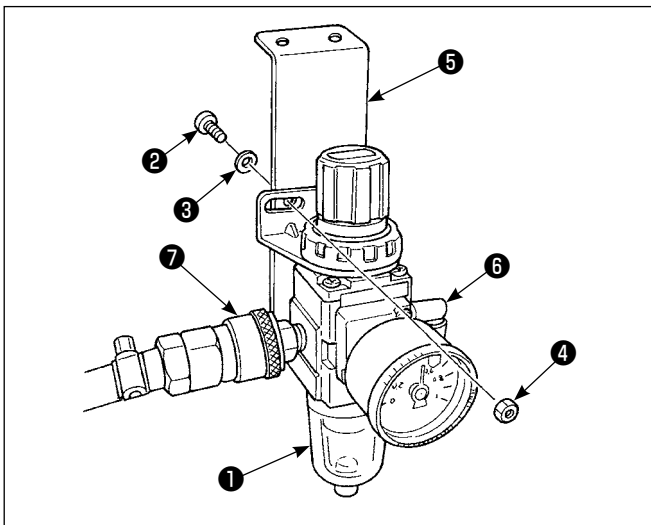

(3) Installing the regulator

- 1) Install regulator (asm.) 1 on mounting plate 5 with screw 2, spring washer 3 and nut 4 which are supplied with the unit.
- 2) Install couplings 6 and 7 on regulator 1.
- 3) Install mounting plate 5 on the underside of the table.
- 4) Connect ø6 air tube coming from the solenoid valve asm. to coupling 6.

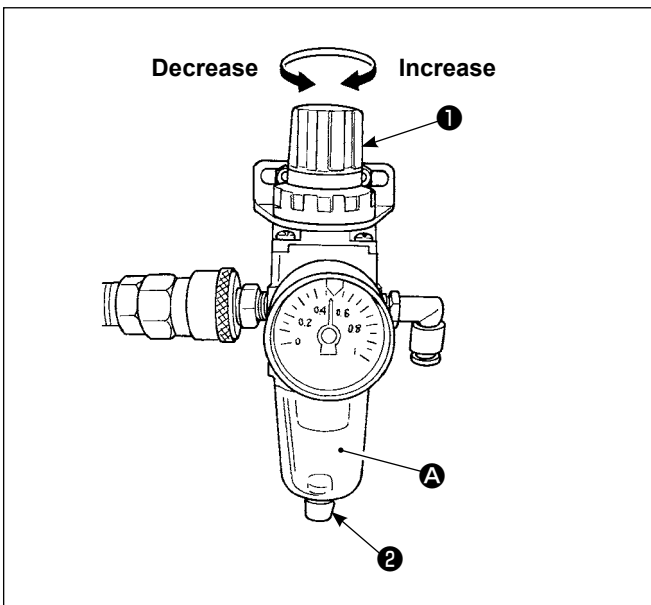

(4) Adjusting the air pressure

- 1) The operating air pressure is 0.5 to 0.55 MPa. Adjust the air pressure with adjusting knob 1 of the regulator.
- 2) When water has accumulated in regulator A section, turn drain cock 2 to drain the water.

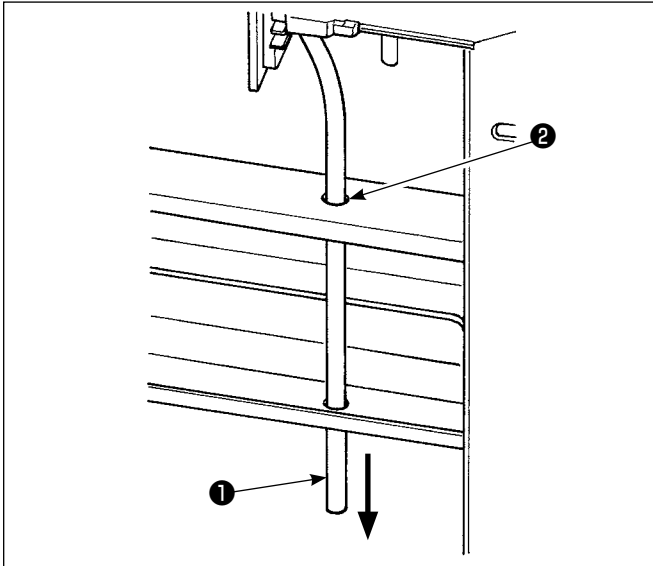

(5) Exhaust tube

Pass $\varnothing 8$ exhaust air tube ① through hole ② in the table stand and other relevant hole. Then, route the air tube downward. If the humidity is high, water may come out of the air tube.

9. WIRING THE MACHINE HEAD



WARNING :

Junction cord preparation and wiring to the control box must be carried out by an electrical engineer without exceptions. Be sure to turn off the power to the sewing machine and wait for five minutes before starting the wiring work.

If the pin numbers of the connectors are not correctly connected, errors and breakage of parts and control box can result. Carefully connect the machine-head connectors and the control-box connectors.

(1) Wiring diagram

Details of the connectors wired to the machine head are as described below.

Refer to "[\(2\) Details of connectors](#)" on the next page for details of connectors ① to ④ and layout of the pins.

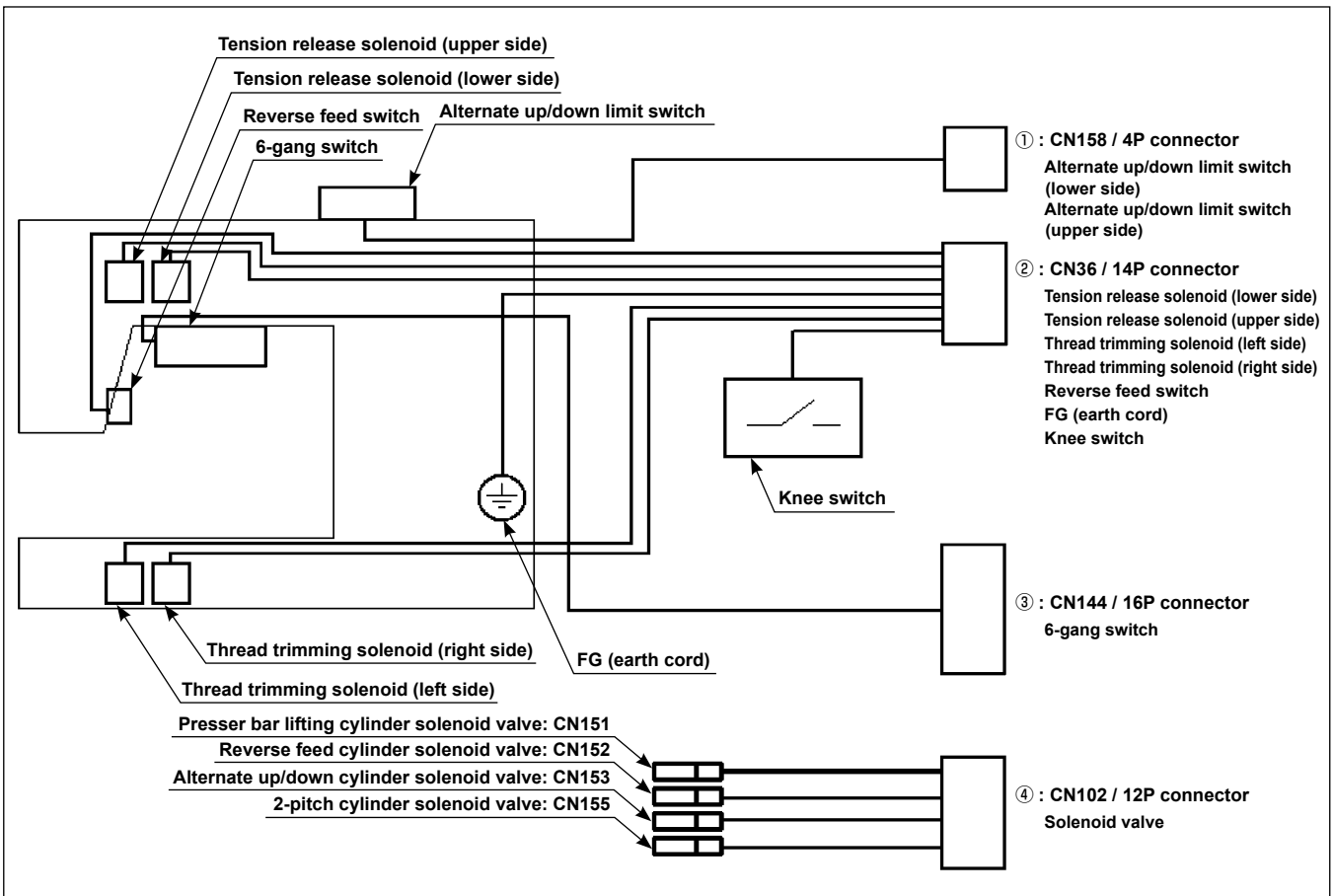

(2) Details of connectors

This clause explains details of connectors ① to ④ and layout of the pins shown in the wiring diagram. Identify the connector pin number as described below.

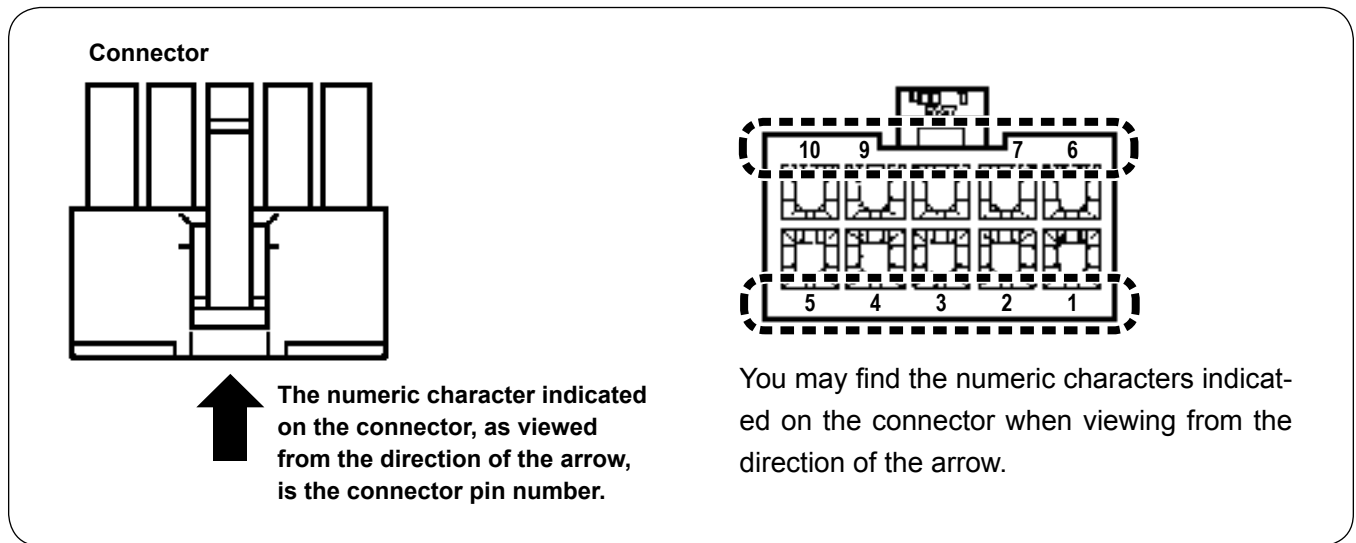

① CN158: 4P connector (alternate up/down switch)

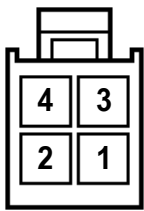

Pin No.	Part name	Color of cable	Remarks
1	Alternate up/down limit switch (lower side)	White	
2	Alternate up/down limit switch (upper side)	Red	
3	Alternate up/down limit switch (lower side)	Black	GND
4	Alternate up/down limit switch (upper side)	Green	GND

* When connecting the connectors to the control box, prepare a junction cord using the below-stated connector pin terminal.
 Part number of the target connector: HK034620040 (MOLEX: 5559-04P)
 Part number of the target pin terminal: HK034630000 (MOLEX: 5558TL)

② CN36: 14P connector (solenoid, switch)

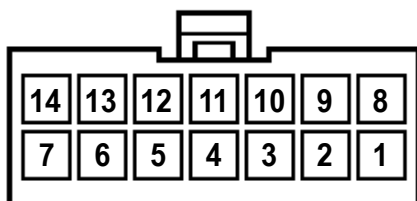

Pin No.	Part name	Color of cable	Remarks
1	Tension release solenoid (lower side)	Black	
2	Tension release solenoid (upper side)	Black	
3	—	—	—
4	Knee switch	White	
5	Reverse feed switch	Black	
6	Thread trimming solenoid (left side)	Black	
7	Thread trimming solenoid (right side)	Black	
8	Tension release solenoid (lower side)	White	Power supply (+27 V)
9	Tension release solenoid (upper side)	White	Power supply (+27 V)
10	FG (earth cord)	Green / Yellow	FG
11	Knee switch	Black	GND
12	Reverse feed switch	White	GND
13	Thread trimming solenoid (left side)	White	Power supply (+27 V)
14	Thread trimming solenoid (right side)	White	Power supply (+27 V)

* When connecting the connectors to the control box, prepare a junction cord using the below-stated connector pin terminal.
 Part number of the target connector: HK034620140 (MOLEX: 5559-14P)
 Part number of the target pin terminal: HK034630000 (MOLEX: 5558TL)

③ CN144: 16P connector (6-gang switch)

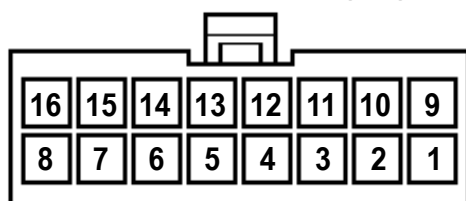

Pin No.	Part name	Color of cable	Remarks
1	6-gang switch	Orange (red dot 1)	+5V * Do not connect the +24V connector. If the +24V connector is connected to this switch, the LED burnout can occur.
2	6-gang switch	Orange (black dot 1)	SW1 (DLSW)
3	—	Gray (red dot 1)	SW2 (Automatic reverse feed prohibition switch)
4	6-gang switch	Gray (black dot 1)	SW3 (One-stitch correction switch)
5	6-gang switch	White (red dot 1)	SW4 (Pitch changeover switch)
6	6-gang switch	White (black dot 1)	SW5 (Thread tension changeover switch)
7	6-gang switch	Yellow (red dot 1)	SW6 (Thread clamp switch)
8	6-gang switch	Yellow (black dot 1)	GND
9	6-gang switch	Pink (red dot 1)	LED1 (DLSW LED)
10	6-gang switch	Pink (black dot 1)	LED2 (Automatic reverse feed prohibition switch LED)
11	6-gang switch	Orange (red dot 2)	LED3 (One-stitch correction switch LED)
12	6-gang switch	Orange (black dot 2)	LED4 (Pitch changeover switch LED)
13	6-gang switch	Gray (red dot 2)	LED5 (Thread tension changeover switch LED)
14	6-gang switch	Gray (black dot 2)	LED6 (Thread clamp switch LED)
15	6-gang switch	White (red dot 2)	SW7 (Machine head fall sensor)
16	—	—	—

* When connecting the connectors to the control box, prepare a junction cord using the below-stated connector pin terminal.
 Part number of the target connector: HK034620160 (MOLEX: 5559-16P)
 Part number of the target pin terminal: HK034630000 (MOLEX: 5558TL)

④ CN102: 12P connector (Solenoid valve)

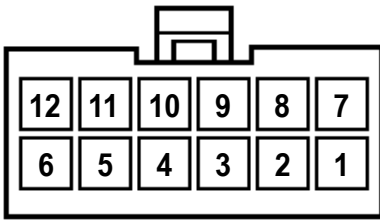

Pin No.	Part name	Color of cable	Remarks
1	Solenoid valve (CN151)	Black	Presser bar lifting cylinder
2	Solenoid valve (CN152)	Black	Reverse feed cylinder
3	Solenoid valve (CN153)	Black	Alternate up/down cylinder
4	—	—	—
5	Solenoid valve (CN155)	Black	2-pitch cylinder
6	—	—	—
7	Solenoid valve (CN151)	Red	+24V
8	Solenoid valve (CN152)	Red	+24V
9	Solenoid valve (CN153)	Red	+24V
10	—	—	—
11	Solenoid valve (CN155)	Red	+24V
12	—	—	—

* When connecting the connectors to the control box, prepare a junction cord using the below-stated connector pin terminal.
 Part number of the target connector: HK034620120 (MOLEX: 5559-12P)
 Part number of the target pin terminal: HK034630000 (MOLEX: 5558TL)

10. AIR PIPING AND MACHINE-HEAD WIRING

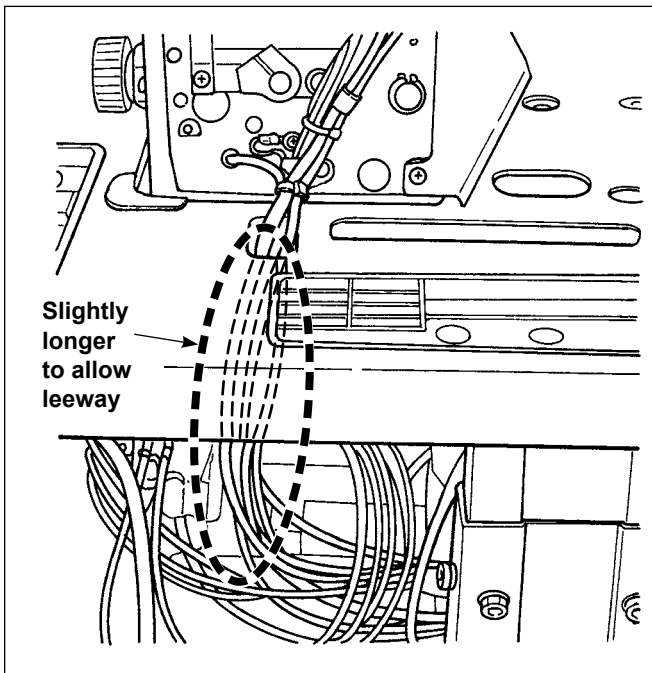

Air pipe and machine-head cord must be sufficiently long, at the time of piping and wiring, to allow the machine head to tilt smoothly.

11. SEWING SPEED TABLE

Operate the sewing machine at a speed equal to or lower than the maximum sewing speed selected from those shown in the table below according to the sewing conditions.

Amount of alternate vertical movement of the walking foot and presser foot	Stitch length : 7 mm or less	Stitch length : More than 7 mm and 9 mm or less
Less than 3 mm	3,000 sti/min *	2,000 sti/min
More than 3 mm and 4 mm or less	2,400 sti/min	2,000 sti/min
More than 4 mm and 5 mm or less	2,000 sti/min	2,000 sti/min
More than 5 mm and 9 mm or less	1,800 sti/min	1,800 sti/min

* For the LU-2860-6, the maximum sewing speed is 2,700 sti/min.



If the sewing machine performs sewing at a speed which exceeds the described one, breakage of part(s) or a decrease in service life can be caused. Be sure to follow the maximum sewing speed.

Refer to the Instruction Manual for the LU-2810, -2810-7, -2860 and -2860-7 packaged with the sewing machine for the installation and adjustment of other parts.

Refer to the clauses which describe the **LU-2810-7** for the **LU-2810-6**.

Refer to the clauses which describe the **LU-2860-7** for the **LU-2860-6**.