

JUKI®

SINGLE-NEEDLE LOCKSTITCH COMPOUND-FEED
AUTOMATIC UNDERTRIMMER
INDUSTRIAL SEWING MACHINE

MODEL

LU2-4652-B1T

INSTRUCTION MANUAL

INTRODUCTION

Thank you very much for purchasing industrial sewing machine.

Please read this instruction manual before operating the sewing machine. Please read also “Safety Manual”, “Instruction manual for LIMISERVO” and operate the sewing machine correctly and safely.

PRECAUTION BEFORE STARTING OPERATION

1 Safety Precautions

1. When turning the power on, keep your hands and fingers away from the area around/under the needle and the area around the pulley.
2. The power must be turned off when the machine is not used, or when the operator leaves his/her seat.
3. The power must be turned off before tilting the machine head, installing or removing the “V” belt, adjusting the machine, or replacing parts.
4. Avoid placing fingers, hairs, obstacles, etc. near the pulley, “V” belt, bobbin winder wheel, or motor when the machine is in operation. Injury could result.
5. Don't put fingers into the thread take-up lever cover, around/under the needle, or pulley when the machine is in operation.
6. If the belt cover, the finger guard, and/or the eye guard are installed, don't operate the machine without these safety devices.

2 Precaution before Starting Operation

1. If the machine's oil pan has an oil sump, never operate the machine without filling oil in it.
2. If the machine is lubricated by a drop oiler, never operate the machine without lubricating.
3. When a new sewing machine is operated, verify the rotational direction of the pulley with the power on.
(The pulley should rotate counterclockwise when viewed from the pulley.)
4. Verify voltage and (single or three) phase indicated on the nameplate of the motor.

3 Precaution for Operating Conditions

1. Avoid using the machine at abnormally high temperature (35°C or higher) or low temperature (5°C or lower). Otherwise, machine failure may result.
2. Avoid using the machine in dusty conditions.
3. Avoid using the machine in conditions filled with a lot of electric noises such as high-frequency welders.

CONTENTS

| | |
|--|----|
| PREPARATION FOR OPERATION | 1 |
| 1 Installing the air cylinder assembly | 1 |
| 2 Connecting the electric cables to the control box | 1 |
| 3 Adjustment of the stitch length before trimming | 3 |
| 4 Operation speed adjustment of instant alternating air cylinder | 4 |
| 5 Height adjustment of the automatic presser foot lifter | 4 |
| 6 Adjustment of the needle stopping position | 5 |
| USAGE PRECAUTION | 6 |
| 1 Lubrication (1) | 6 |
| 2 Lubrication (2) | 6 |
| 3 Lubrication condition | 7 |
| 4 Adjustment of lubrication to the rotating hook | 7 |
| 5 Precaution for the built-in type detector | 7 |
| 6 Installation of the belt cover | 7 |
| 7 Precaution on operation | 7 |
| HOW TO USE | 8 |
| 1 Installation of the needle | 8 |
| 2 Winding of the bobbin thread | 8 |
| 3 Selection of the thread | 9 |
| 4 Threading of the needle thread | 9 |
| 5 Adjustment of feed (stitch) length and backstitch | 10 |
| 6 Setting of the bobbin | 10 |
| 7 Adjustment of the needle thread guide | 10 |
| 8 Threading of the bobbin thread | 11 |
| 9 Adjustment of the bobbin thread tension | 11 |
| 10 Balance of threads tension | 11 |
| 11 Adjustment of the needle thread tension | 11 |
| 12 Adjustment of the presser foot pressure | 11 |
| 13 Adjustment of the outside presser foot and inside presser foot | 12 |
| 14 Instant alternating switch | 13 |
| 15 The stopper screw for adjusting the maximum alternating stroke | 13 |
| 16 Installing the feed regulator bracket | 14 |
| 17 Adjustment of the alternating stroke sensing potentiometer | 14 |
| 18 Timing between the rotating hook motion and the needle motion | 15 |
| 19 Adjustment of the feed dog height | 16 |
| 20 Relationship between the rotating hook motion and the thread take-up lever motion | 17 |
| 21 Relationship between the rotating hook motion and the opener motion | 17 |
| 22 Relationship between the needle motion and the feed dog motion | 18 |
| 23 Safety clutch | 19 |
| 24 Adjustment of upper feed length (needle side) | 20 |
| 25 Adjustment of forward/backward feed length | 20 |
| 26 Installation of the movable knife | 21 |
| 27 Installation position of the thread trimmer cam | 22 |
| 28 Adjustment of the thread trimmer cam | 22 |
| 29 Adjustment of the thread tension releasing | 23 |
| 30 Adjustment of meshing pressure between the movable knife and the fixed knife | 24 |
| 31 Sharpening of the fixed knife | 24 |
| SPECIFICATIONS | 25 |

PREPARATION FOR OPERATION

1 Installing the air cylinder assembly

- (1) Align the air cylinder assembly to the back of the arm as shown below and then fit the driving link into the pin.
Fit a driving link between the nylon washers.
- (2) Install the air cylinder assembly on the back of the arm.
Tighten the bracket and the back of the arm with the enclosed bolt.

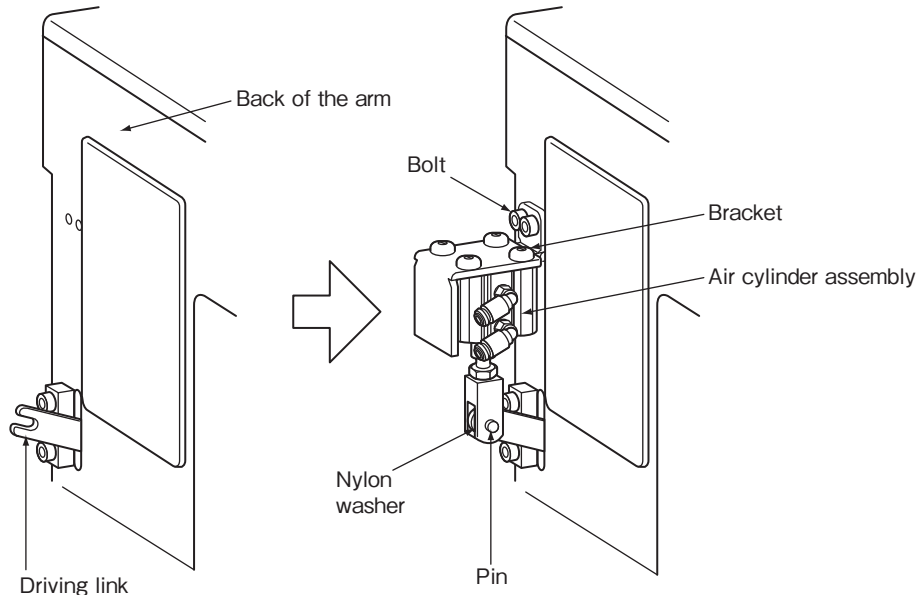

2 Connecting the electric cables to the control box

Connect wires and pipes as follows.

- (1) Install the solenoid valve and the filter regulator assembly ① within the reach of the urethane tube /cord under the table.
- (2) Install two attached elbow unions ②, ③ on the rear cover locating at the back of the arm.
- (3) Arrange piping by urethane tubes between the upper elbow union ② installed by step (2) and the port B (④ B) of the upper presser foot lifter solenoid valve ④, and between the lower elbow union ③ and the port A (④ A).
- (4) Connect the connector ⑤ of the presser bar lifter solenoid valve ④ to the presser foot lifter connector on the control box.
- (5) Connect the urethane tube ⑥ from the top of the sewing machine to the port A (7 ① A) of the instant alternating solenoid valve ⑦.
- (6) Connect the 3-pin connector ⑧ of the sewing machine connector and the connector of the instant alternating solenoid valve ⑦.
- (7) When the knee switch ⑨ is substituted for the instant alternating switch, connect the 2-pin connector ⑩ supplied as an option B to the knee switch.

PREPARATION FOR OPERATION

(8) Connect by urethane tube between the upper part elbow unions ⑪ installed on the air cylinder assembly and port A of the solenoid valve assembly ⑬.

Similarly, connect the urethane tube between lower side of elbow unions ⑫ and port B of the solenoid valve assembly.

(9) Connect the air supply source to the IN port of the filter regulator ①.

(10) Tie together urethane tubes and cords with attached binding bands.

Note: Set the standard air pressure of the regulator to 0.4 MPa (4 kgf/cm²).

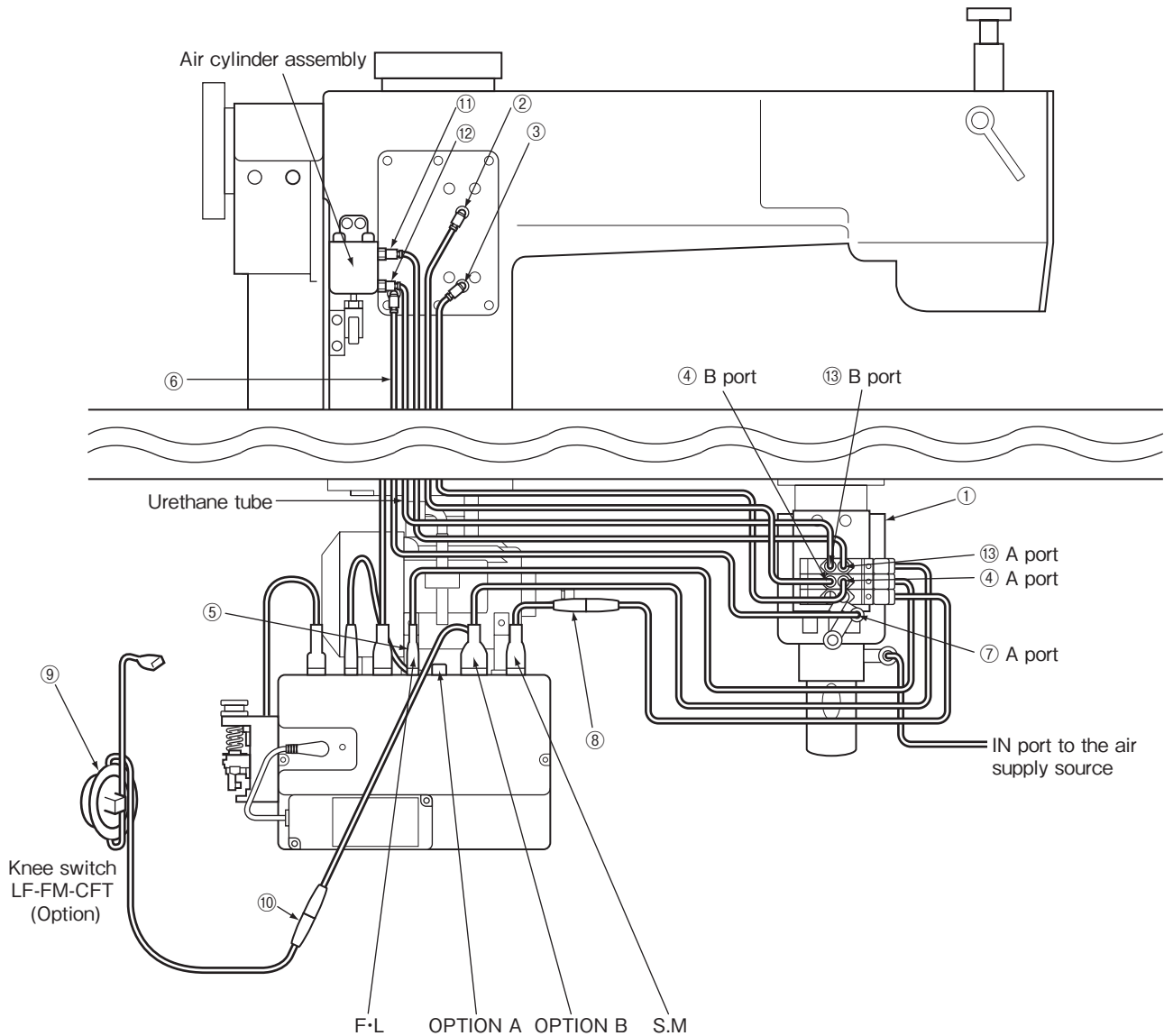

PREPARATION FOR OPERATION

3 Adjustment of the stitch length before trimming

Depending on sewing conditions, the stitch immediately before trimming may not be formed correctly. This may cause the trimmed tail length to be long.

In this case, adjust the length of the stitch immediately before the trimming position to ensure that a proper stitch is formed. As reference, the standard stitch length is 1 to 2 mm. The length of the stitch immediately before trimming can be adjusted by moving the position of the knuckle to the air cylinder shaft up/down. Adjust with the following methods.

- (1) Loosen the nut on the knuckle.
- (2) Rotate the air cylinder shaft.
Adjust the position of the knuckle to the air cylinder shaft.
- (3) The stitch immediately before trimming is as follows.
 - During forward stitching:
Looking from above, turn the shaft clockwise to change to reverse stitching.
 - Too short during reverse stitching:
Looking from above, turn the shaft clockwise.
 - Too long during reverse stitching:
Looking from above, turn the shaft counterclockwise.The stitch length changes about 1 mm when the shaft is rotated once.

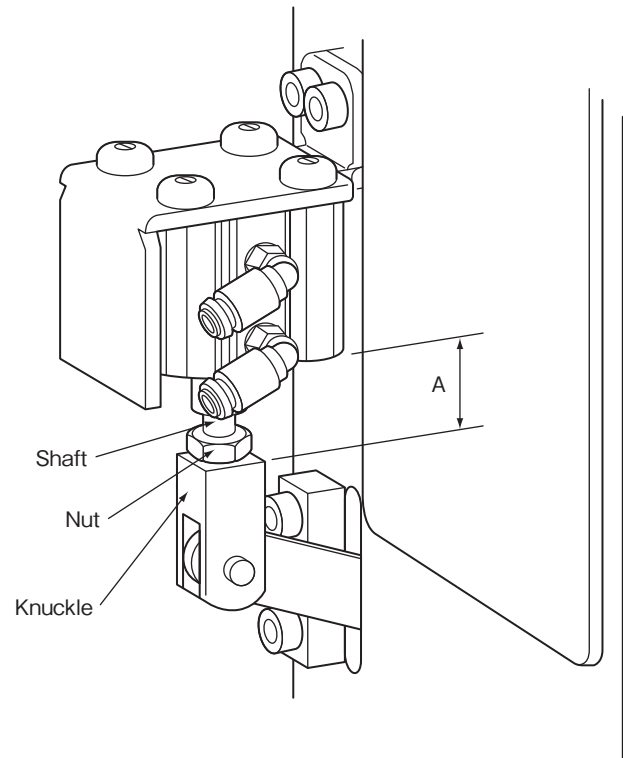

In the position of the knuckle when shipping, dimension A between the lower surface of the air cylinder and the upper surface of the knuckle is 22 mm like the right figure with the air cylinder drawn in.

PREPARATION FOR OPERATION

4 Operation speed adjustment of instant alternating air cylinder

- (1) To adjust the speed of the air cylinder at the maximum instant alternating, adjust the handle ① with plated locknut on the dual speed controller of the instant alternating solenoid valve (lower side).
- (2) To adjust the speed of the air cylinder at the instant alternating return, adjust the handle ② with the black colored locknut on the dual speed controller of the instant alternating solenoid valve (lower side).

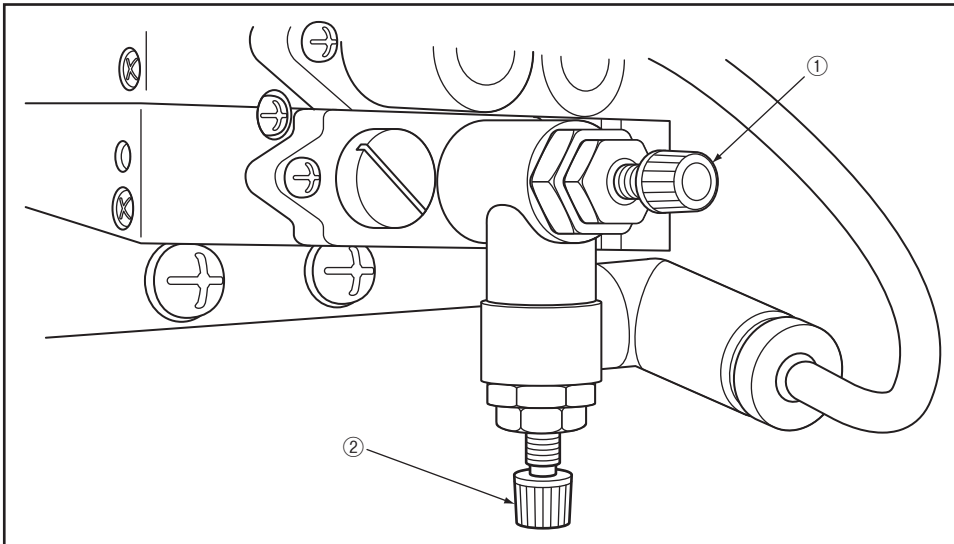

5 Height adjustment of the automatic presser foot lifter

The presser foot lifter height at the automatic presser can be adjusted.

- (1) Remove the top cover.
- (2) Slide the stopper plate on the presser foot lifter air cylinder up and down to adjust.

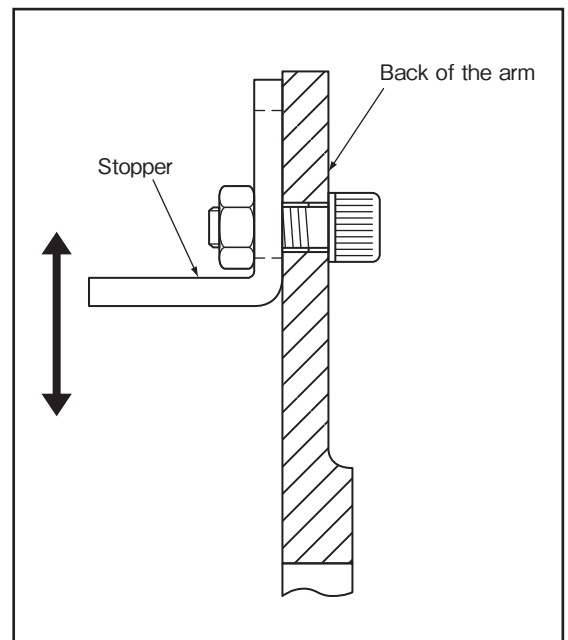

PREPARATION FOR OPERATION

6 Adjustment of the needle stopping position

1. Adjustment of "UP" position

When the pedal is kicked down by heel, the machine stops at "UP" position.

If marks deviate larger than 3 mm, adjust as follows.

- (1) Disconnect the plug (12 pins) of cable from the machine head.
- (2) Run the machine and stop at "UP" position.
- (3) While holding the pulley, insert the "Adjusting tool" in the hole (A), then turn the tool.

2. Adjustment of "Down" position

When the pedal is "Neutral" the machine stops at "Down" position.

If marks deviate large than 5 mm, adjust as follows.

- (1) Disconnect the plug (12 pins) of cable from the machine head.
- (2) Run the machine and stop at "Down" position.
- (3) While holding the pulley, insert the "Adjusting tool" in the hole (B), then turn the tool.

3. Confirm the stop operation, then set the plug (12 pins) coming from the machine head into the receptacle.

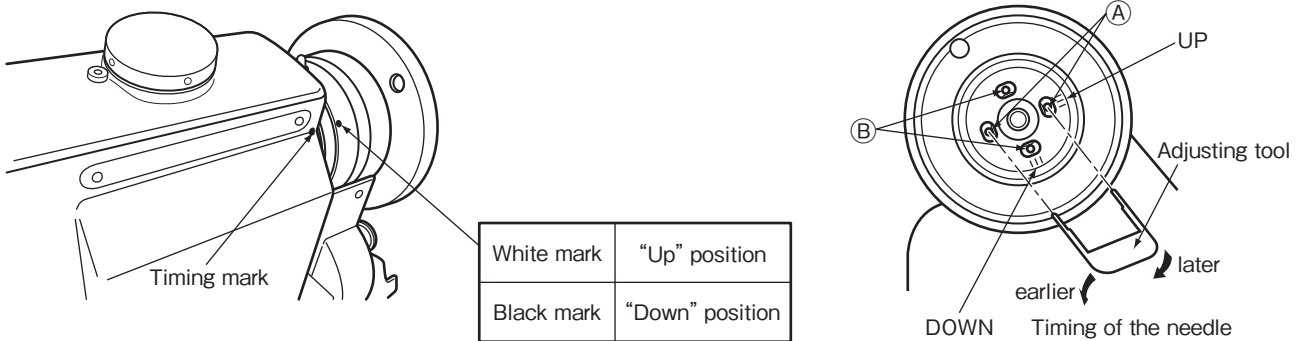

USAGE PRECAUTION

1 Lubrication (1)

Fill the oil reservoir with oil up to “H” mark.
Oil level should be periodically checked. If oil level is found below “L” level replenish oil to “H” level.
For oil, use “MC70M” specified by our company.

※ Refer

MC70M : Specific gravity (15°C) = 0.86 (g/cm³)
: Viscosity (40°C) = 10.9 (mm²/s)

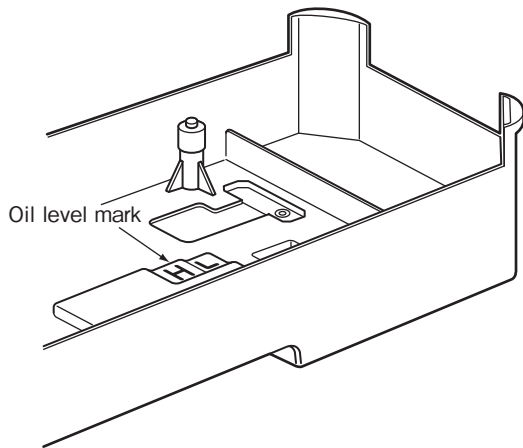

2 Lubrication (2)

When a new sewing machine is used for the first time, or sewing machine left out of use for considerably long time is used again, replenish a suitable amount of oil to the portions indicated by arrows in the below figure.

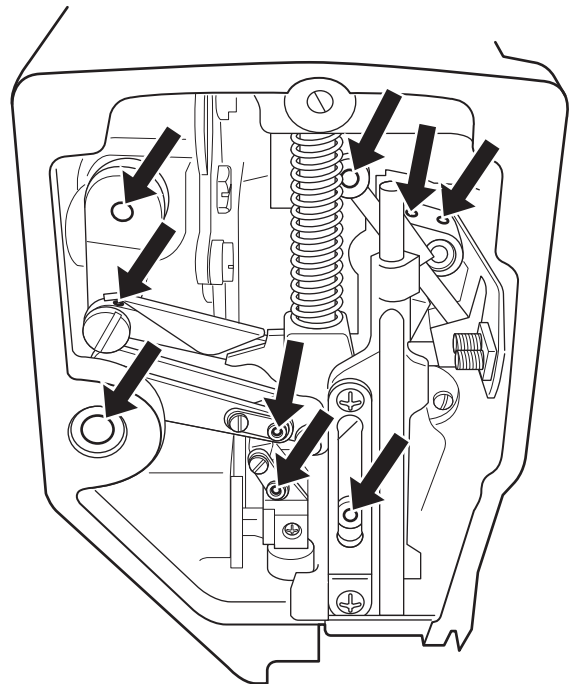
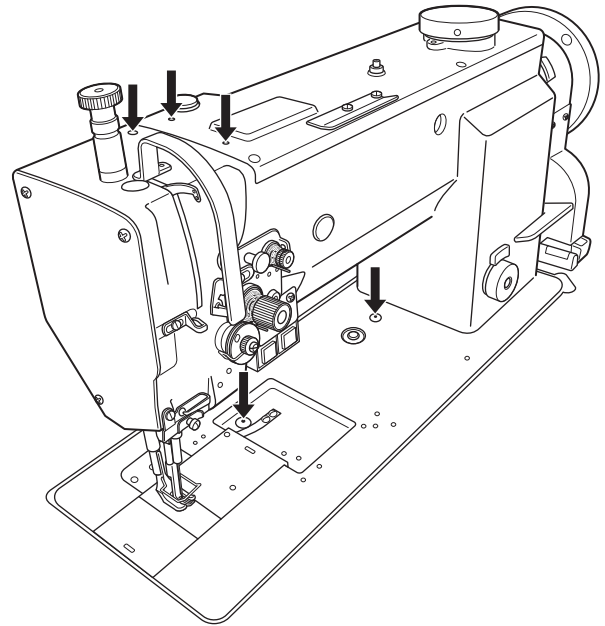

USAGE PRECAUTION

3 Lubrication condition

See dripping of oil through the oil sight window to check oiling condition during operation.

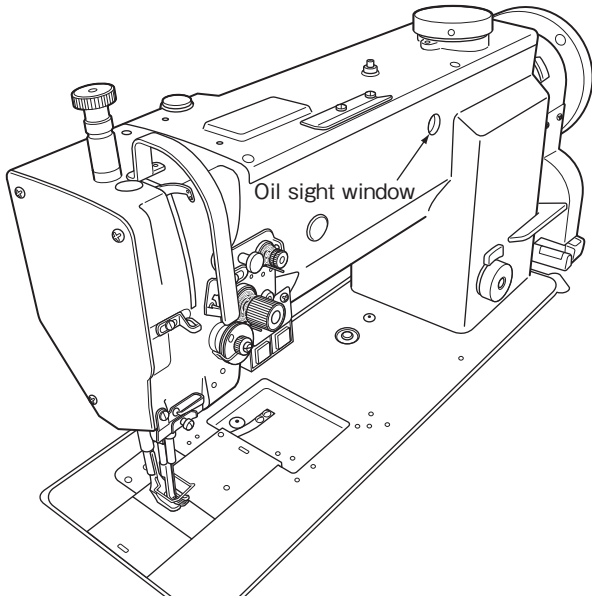

4 Adjustment of lubrication to the rotating hook

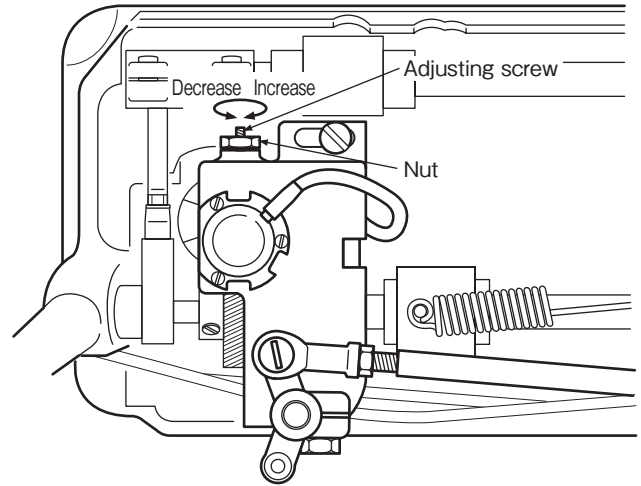

5 Precaution for the built-in type detector

1. Since the optical type detecting element is used in the detector, prevent dust or oil from sticking to the detecting plate when the sewing machine pulley is removed for adjustment. If they have stuck, wipe them off with soft cloth carefully so that the surface is not scratched, do not let oil permeate the clearance on the detecting plate.
2. In case of disconnection of the position detector connector, running off the belt or complete constraint and over load, the motor is automatically turned off after predetermined time to prevent burning of the motor. (However, in case of half-constraint and over load, the power may not be turned off.) After the failure is eliminated, the normal operation is resumed by turning off the power once then turning on again. The same operation occurs for the detector malfunction or the line breakage.

6 Installation of the belt cover

1. Install the belt cover on the machine side for safety. Refer to the provided instruction document contained in the same package.
2. Install the belt cover on the motor side for safety.

7 Precaution on operation

- (1) When the power is turned on or off, keep foot away from the pedal.
- (2) It should be noted that the brake may not work when the power is interrupted or power failure occurs during sewing machine operation.
- (3) Since dust in the control box might cause malfunction or control troubles, be sure to keep the control box cover close during operation.
- (4) Do not apply a multimeter to the control circuit for checking, otherwise voltage of multimeter might damage semiconductor components in the circuit.

HOW TO USE

1 Installation of the needle

Note: Before installing the needles, be sure to turn off the power.

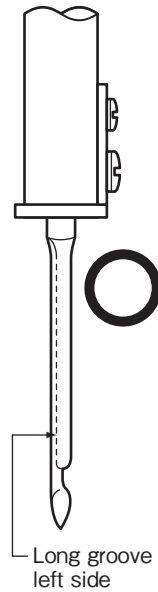

2 Winding of the bobbin thread

Note: When bobbin thread is wound, keep the presser foot lifted.

- Adjustment ● **Tension of wound thread** Slack winding is recommended for polyester thread and nylon thread.
- **Conically wound thread** Move the thread guide toward smaller diameter of wound thread layer.
- **Amount of wound thread** Loosen the winding amount adjustment screw to decrease thread winding amount and tighten the screw to increase thread winding amount.

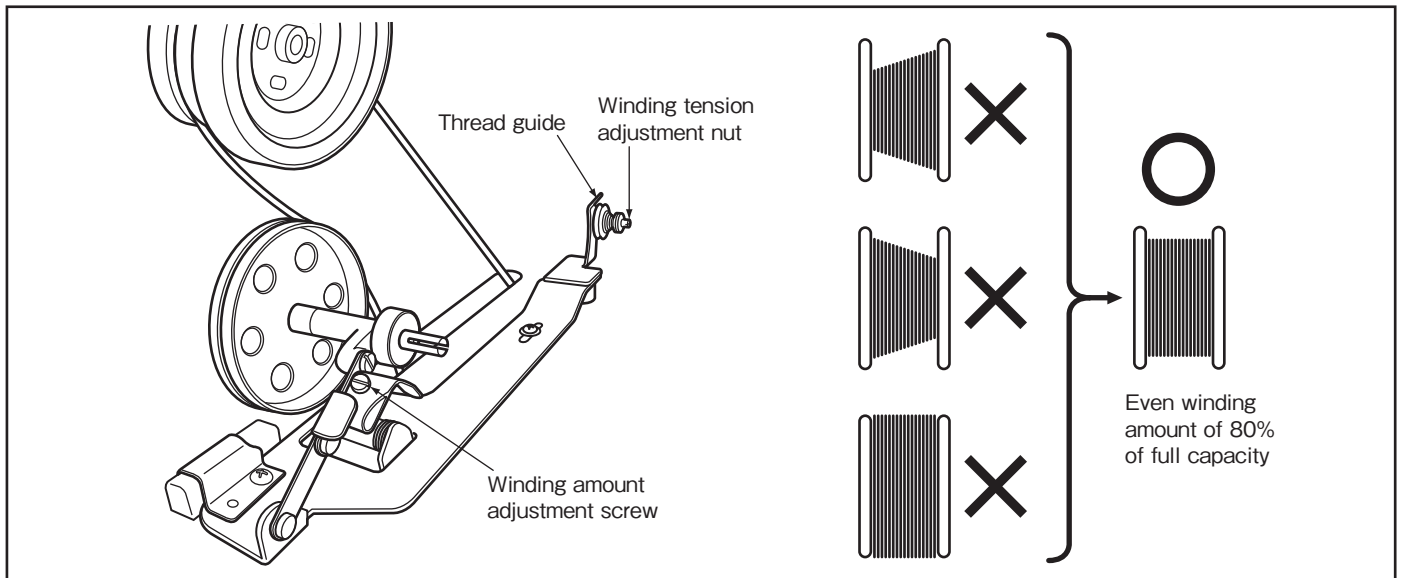

HOW TO USE

3 Selection of the thread

It is recommended to use “S” twist thread in the left needle (viewed from front), and “Z” twist thread in the right needle.

When discriminate use of needle threads is impossible, use “Z” twist thread in both the needles.

For bobbin thread, “S” twist thread as well as “Z” twist thread can be used.

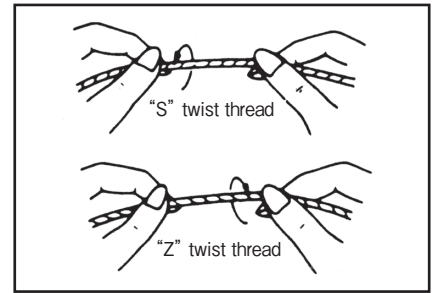

4 Threading of the needle thread

1. Pass each needle thread through thread guide (A).
Note: When thin slippery thread (polyester thread or filament thread, etc.) is used,
Pass the thread through thread guide (B) as well.
2. With the thread take-up lever located at the upper most position, pass each needle thread in the order shown in the following figure.
Note: Pushing the needle thread tension releasing button shown in the figure below opens the saucer of the needle thread tension adjuster, and the needle thread can easily pulled out.

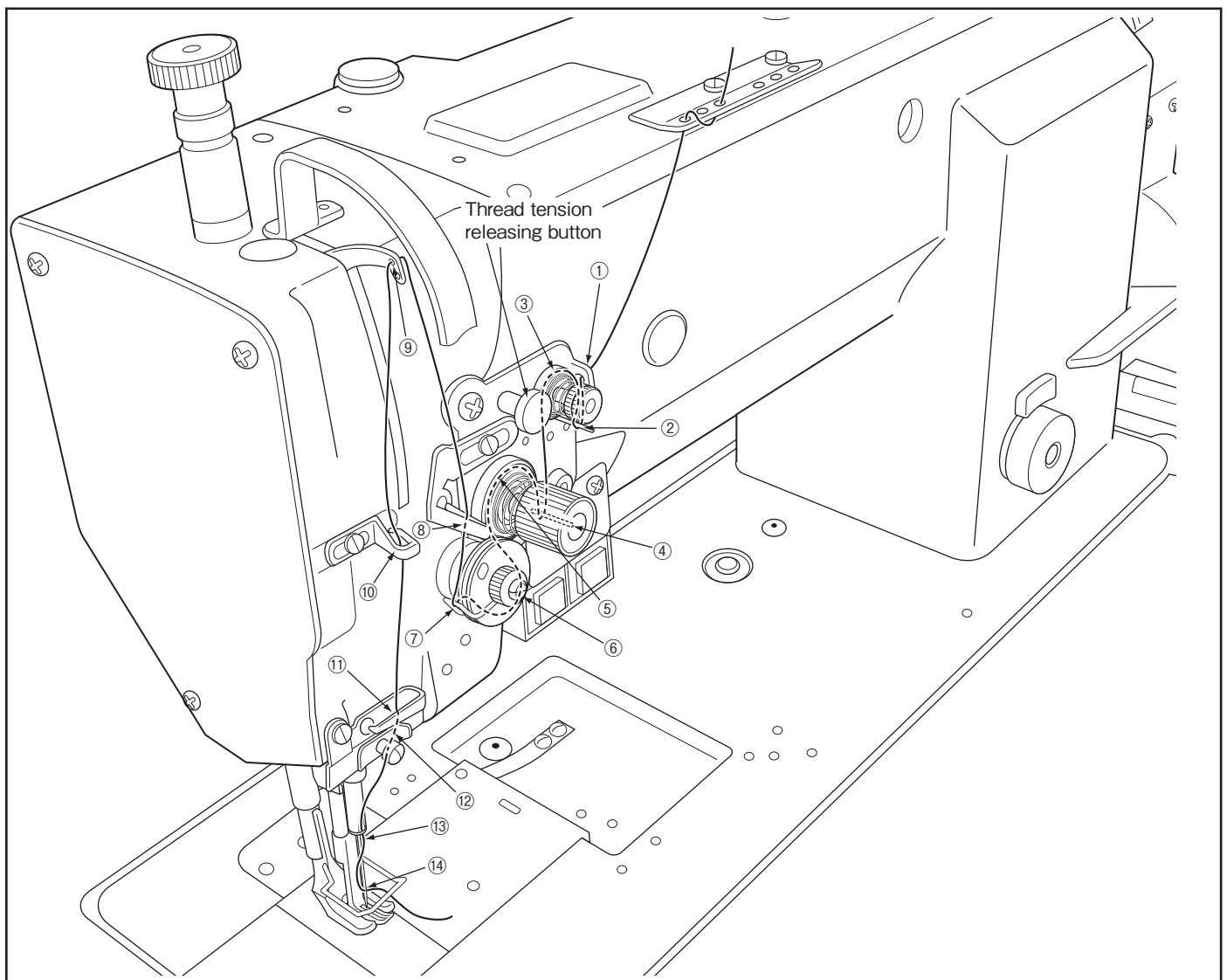
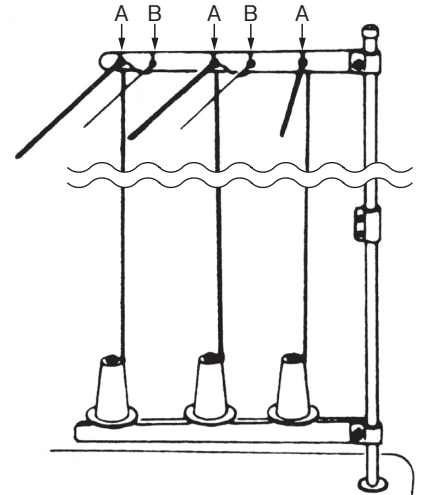

HOW TO USE

5 Adjustment of feed (stitch) length and backstitch

● Adjustment of feed (stitch) length... Adjust feed length by turning the feed length setting dial while pushing PUSH lever.

Note: Depending upon the stitch length, the maximum sewing speeds are different. With referring to the specifications on page 25, please operate the sewing machine at the speed less than the matching sewing speed with the stitch length.

● Backstitch... Direction of stitching can be reversed by depressing the reverse sewing lever or pushing the touch back switch.

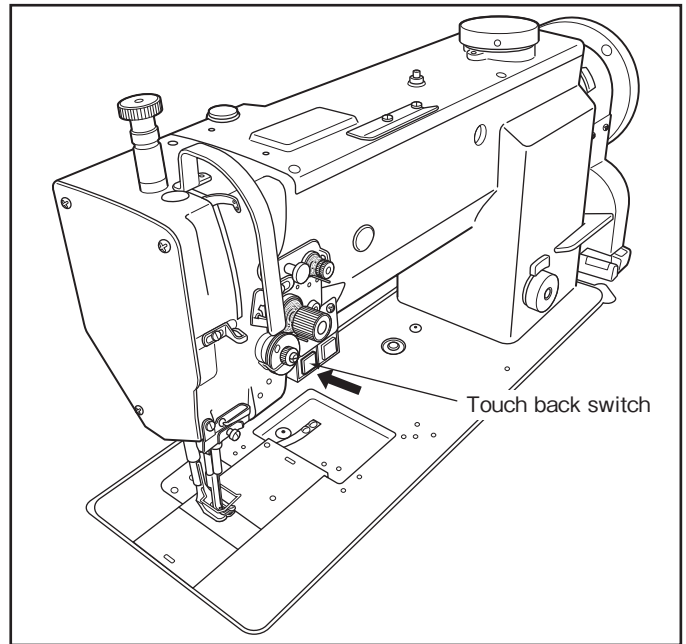
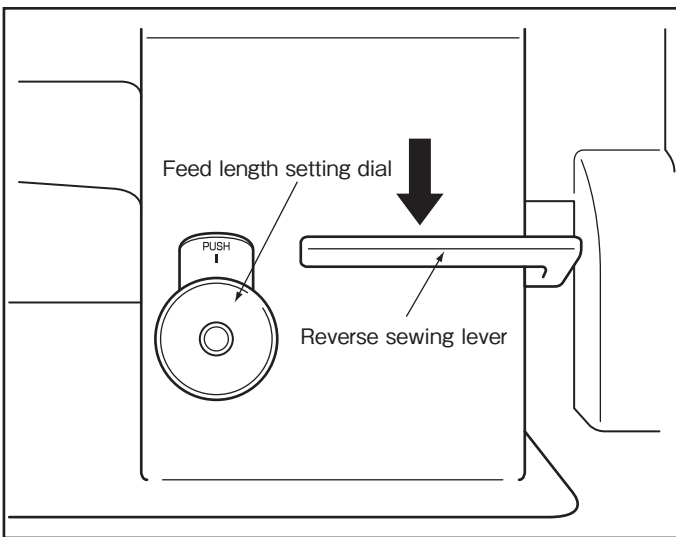

6 Setting of the bobbin

- (1) Pull out 5 cm thread tail from the bobbin.
- (2) Put the bobbin into the hook in the direction as the following figure.

7 Adjustment of the needle thread guide

Adjust the needle thread guide of the needle thread tension adjuster according to the fabric, the thread, and sewing condition.

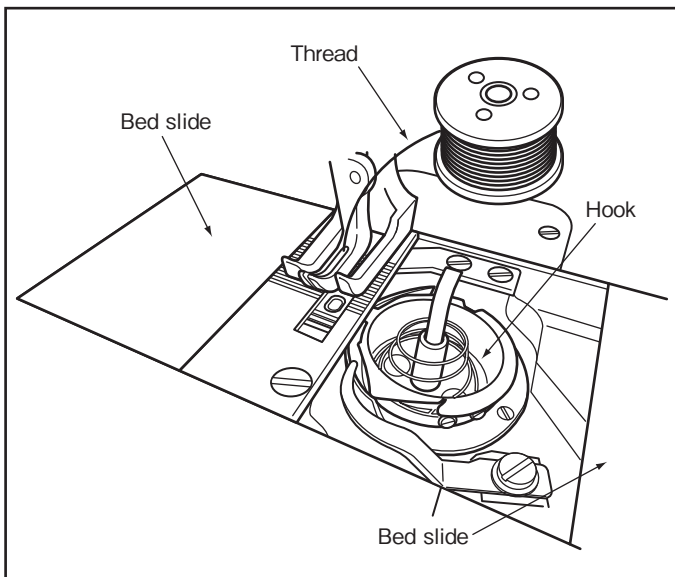

| Needle thread guide position | Left side | Center | Right side |
|------------------------------|-----------|----------|------------|
| Fabric | Heavy | Standard | Light |
| Needle thread supply | More | Standard | Less |

HOW TO USE

8 Threading of the bobbin thread

(1) Put bobbin thread into the slit ①, pass under the lug ② and extend it above the bed.

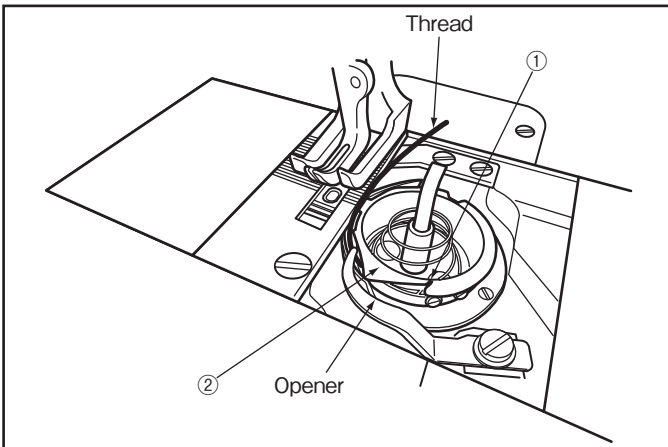

(2) While holding two needle threads with your left hand, turn the pulley one rotation with your right hand. The bobbin threads will come up when needle threads are lifted up as shown in the figure. Needle threads and bobbin threads should be aligned and led backward together.

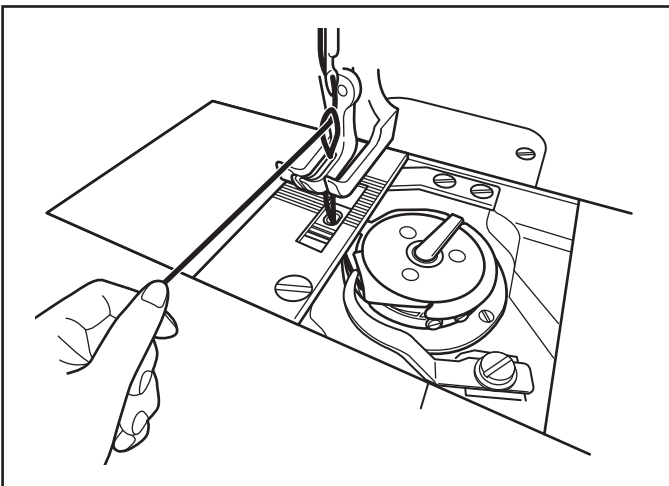

9 Adjustment of the bobbin thread tension

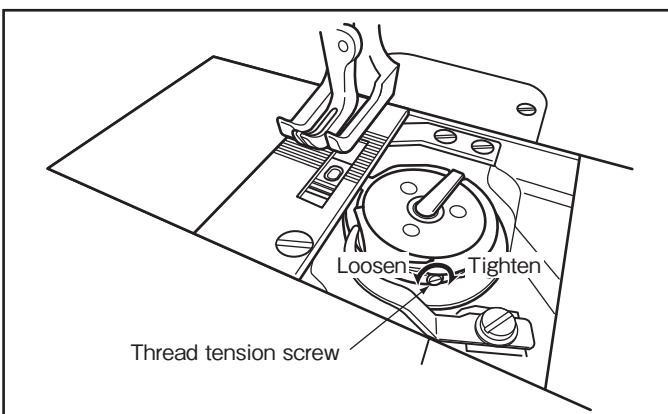

10 Balance of threads tension

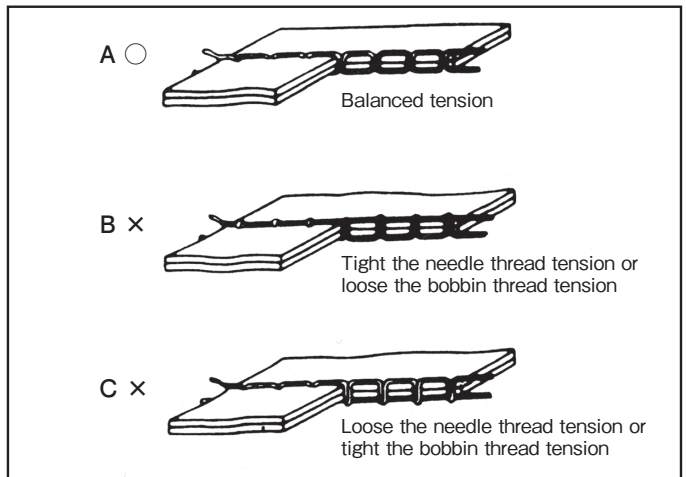

11 Adjustment of the needle thread tension

To adjust needle thread tension, turn the thread tension nut.

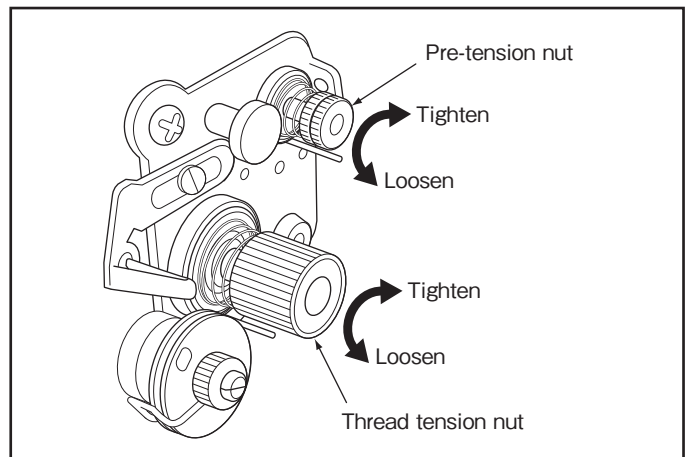

12 Adjustment of the presser foot pressure

Adjust the presser foot pressure according to the fabric by turning the pressure adjusting screw.

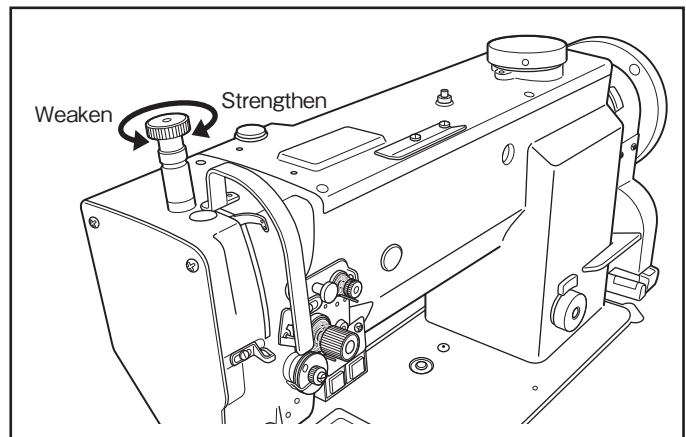

HOW TO USE

13 Adjustment of the outside presser foot and inside presser foot

1 . Adjustment of alternating movement

- (1) The alternating movement on the outside presser foot and inside presser foot can be adjusted by using the adjusting dial located on the top cover.
- (2) Face the desired number printed on the dial to the matching mark located on the top cover.
- (3) The number printed on the dial represents the possible protrusion of the outside presser foot and inside presser foot from the throat plate when the alternating movements on these are evenly set.
- (4) If the alternating movements are evenly set, they can be readjusted up to 2.0 to 6.0 mm.

2 . To change the balance of the alternating movements between the outside presser foot and inside presser foot

- (1) For example, to increase the rise of the inside presser foot, and decrease the rise of the outside presser foot.
 - ① Remove the rubber plug located on the top cover.
 - ② Turn the pulley until the outside presser foot is slightly raised from the throat plate.
 - ③ Loosen the set screw **A** located on the feed lifting rock shaft crank (right).
 - ④ The built-in spring pulls down the outside presser foot until it makes contact with the throat plate. Then, tighten the set screw **A**.
 - ⑤ This completes the adjustment, i.e., the protrusion of the outside presser foot has been decreased by a set distance. And, the vertical motion of the inside presser foot has been increased by that same distance.
- (2) As a contrary case (1), to decrease the rise of the inside presser foot, and increase the rise of the outside presser foot.

First, turn the pulley until the inside presser foot is slightly raised from the throat plate. Next, loosen the screw **A**. Finally, tighten the screw **A** again.

This decreases the rise of the inside presser foot.

3 . How to install the upper eccentric feed lifting cam

- (1) Turn the pulley and stop it at the position where the thread take-up lever comes to the lowest.
- (2) In this condition, remove the rubber plug located on the arm. Locate the second screw **A** in the upper eccentric feed lifting cam as shown in the figure. And tighten it.

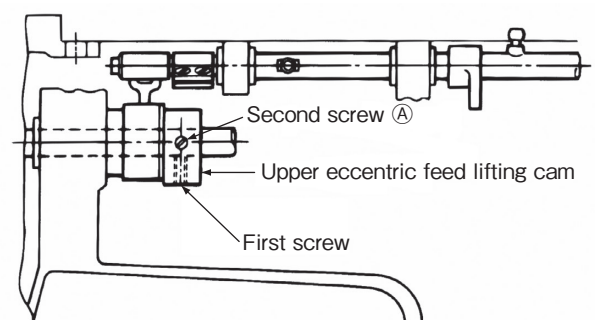
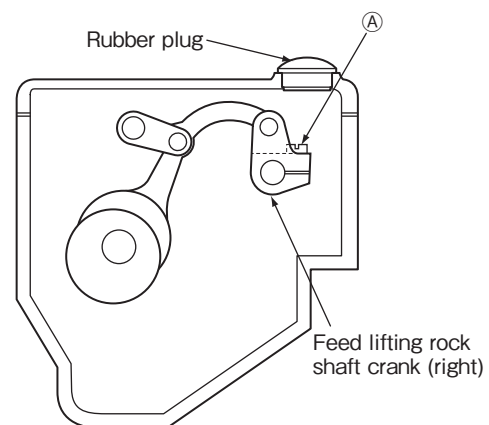
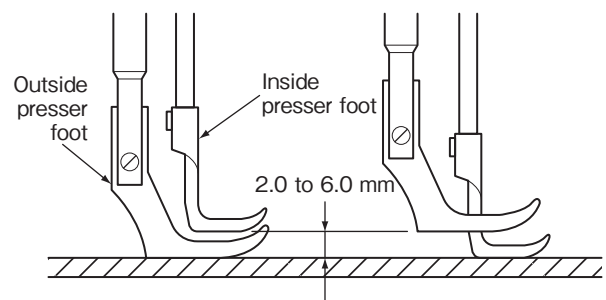
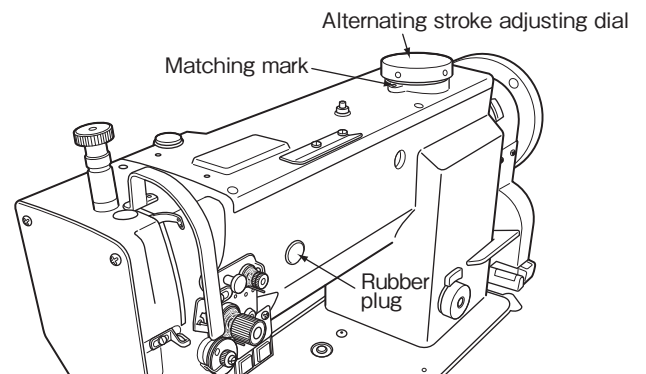

HOW TO USE

14 Instant alternating switch

During the sewing operation, if a sewing material has a step, hit the instant alternating switch, then the alternating up and down movement instantly becomes much bigger to get over the step.



(Lighting LED lamp)

Hit once, ON The alternating up and down movement becomes highest (It is adjusted 6 mm is the highest when the sewing machine is shipped from the factory).



Hit twice, OFF The alternating up and down movement becomes the normal stroke controlled with the alternating stroke adjusting dial.

Note 1: The knee switch also can be used as the instant alternating switch.

2: It also can be set the alternating up and down movement to the highest only while pressing the instant alternating switch.

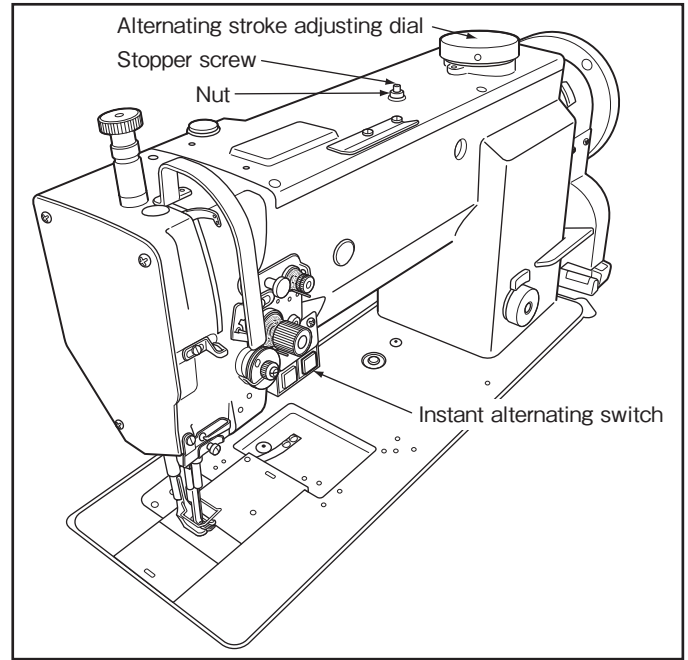

15 The stopper screw for adjusting the maximum alternating stroke

The maximum alternating stroke can be adjusted with the stopper screw shown in the right figure.

©The maximum alternating stroke is fixed at 6 mm when the sewing machine is shipped from the factory.

If the maximum alternating stroke is required to make smaller, take the following procedures.

Note: Do not set the alternating stroke to more than 6.5 mm, because it may cause failure.

1. Set the alternating stroke adjusting dial to the desired number of the stroke.
2. Loosen the nut shown in the right figure.
3. Tighten the stopper screw until it hits with the special screw.
4. Tighten the nut.

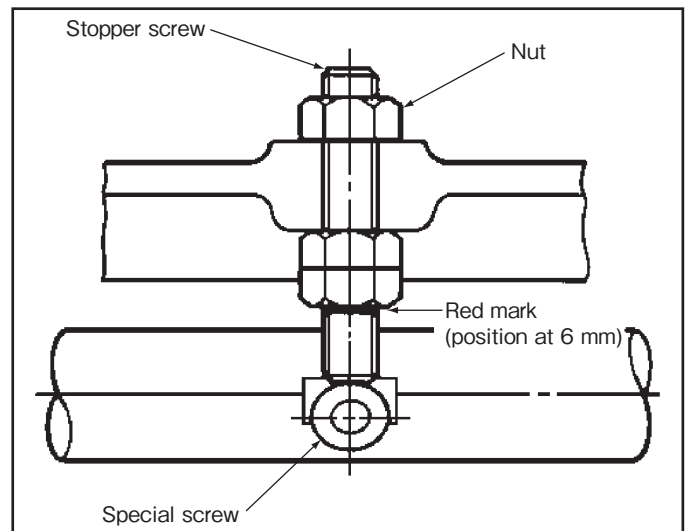

HOW TO USE

16 Installing the feed regulator bracket

If it is necessary to dismount and reassemble the feed regulator bracket and its related parts, install it as follows.

Note: If the feed regulator bracket is poorly positioned, the resultant alternating movements may be too short or long causing defective machine operation.

- (1) Set the gap between special screw **(A)** located on the regulator shaft and the side wall of the machine arm to 42.6 mm as illustrated to the left. (Use a 42.6 mm spacer between these parts. This facilitates the operation.)
- (2) With the feed regulator stud held as explained in step (1) above, adjust the feed regulator bracket. This adjustment should insure a gap of 2.3 mm between the periphery of pin **(B)** located on the feed regulator bracket and the top cover installing face located on the arm. Tighten screw **(C)**.

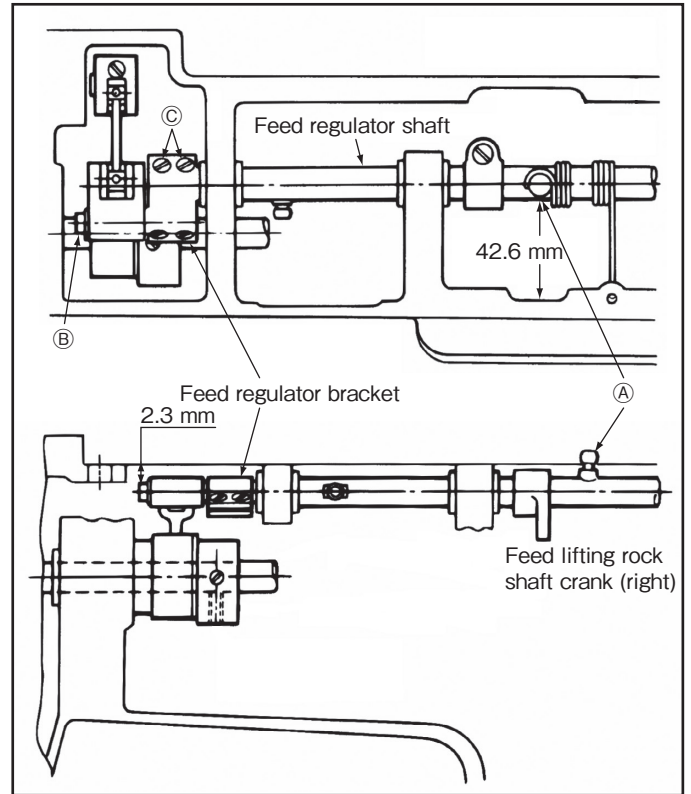

17 Adjustment of the alternating stroke sensing potentiometer

(Please refer to the instruction manual for LIMISERVO X GMFY also.)

Note: In case of maladjustment, the proper sewing speed may not be obtained.

- (1) Turn off the power switch.
- (2) Remove all connectors except OPTION B connector.
- (3) Remove the top cover in the condition which set the alternating stroke adjusting dial for scale 2.
- (4) Turn on the power switch, and then set the operation panel of the control box to the input display "V2" at the programming mode E.
- (5) Loosen the slotted bolt **(D)** of the potentiometer crank.

At this time, be careful not to give any bending torque to the potentiometer shaft.

- (6) Fix the distance between the feed regulator shaft special screw **(A)** and the inner wall of the sewing machine arm 42.6 mm. (It is recommended to use the spacer sized 42.6 mm for quick fixing.)
- (7) Turn the potentiometer shaft so that the input display "V2" indicates 280 to 289.

- (8) Tighten the slotted head bolt **(D)** of the potentiometer crank.
- (9) Make sure again that the input display "V2" indicates 280 to 289. If the display indicates the different number from 280 to 289, adjust the potentiometer shaft again.
- (10) Turn off the power switch.
- (11) Put the top cover back in the condition which set the alternating stroke adjusting dial for scale 2.
- (12) Connect all the connectors as before.

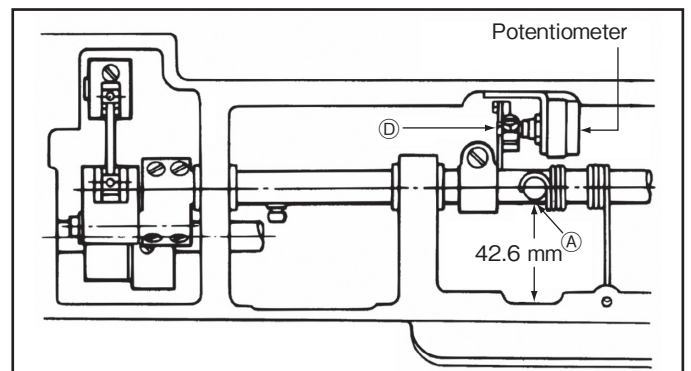

HOW TO USE

18 Timing between the rotating hook motion and the needle motion

Note: If you remove the presser foot, the throat plate, and the feed dog, it makes easier to adjust.

- (1) Set feed length to 6 mm.
- (2) Loosen all screws ①, ②, ③.

Note: Be careful not to disengage the large gear and the small gear.

- (3) Lift the needle bar 2.4 mm from the lowest position. Refer to timing marks shown in the figure.
- (4) Slide the hook saddle right and left so that the gap between the tip of the hook and the scarf of the needle is 0.05 mm or lower.

- (5) Tighten screws ①, ②.

Note: Be careful not to overtighten screw ②.

- (6) Slide the large gear right and left so that the tip of the hook position is in the center of the needle and tighten screws ③.

Note: Check the large gear and the hook saddle isn't in contact and its distance is less than 3 mm.

- (7) Move the tip of the hook to the needle side by turning the pulley.
- (8) Return the machine head to the original position and adjust the needle guide position so that it comes lightly in contact with the needle.

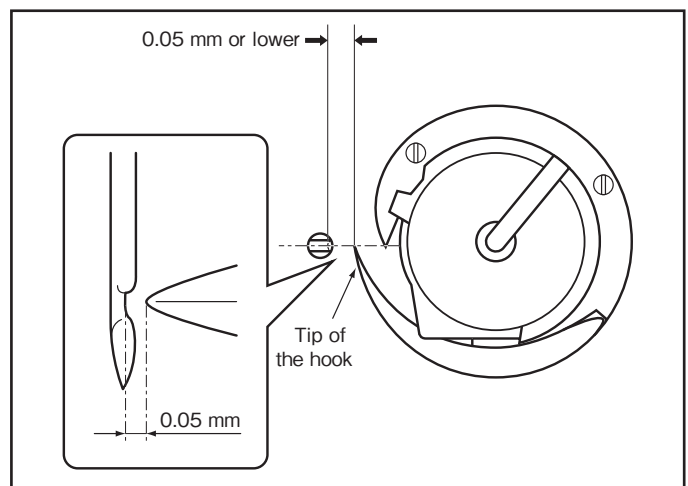
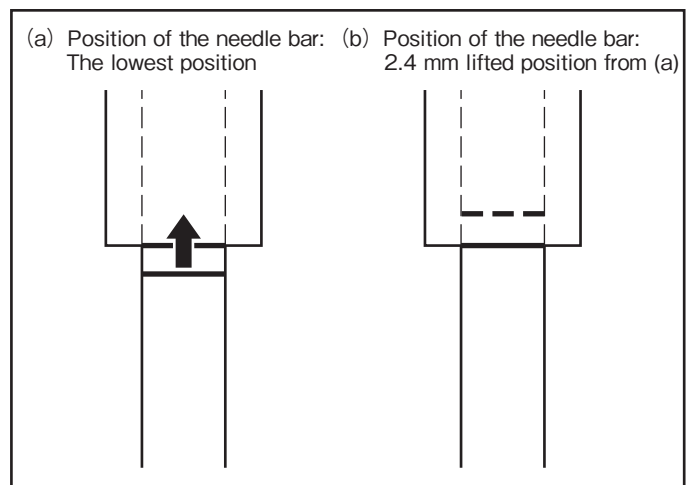
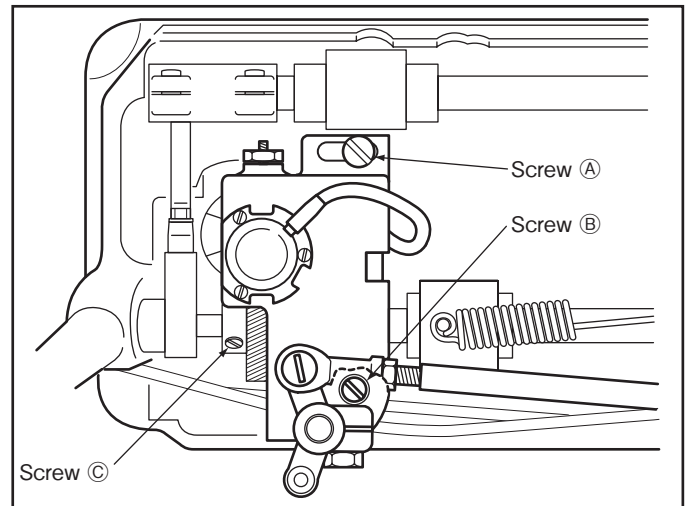

HOW TO USE

19 Adjustment of the feed dog height

The feed dog height and the presser foot pressure must be adjusted according to the fabric.

- ◆ The fabric will be damaged if the feed dog extends too high, or if the presser foot pressure is too large.
- ◆ An even stitch length cannot be assured if the feed dog is too low, or if the presser foot pressure is too small.
- ◆ The feed dog height is the position where the needle is at the top position.

Adjustment of the feed dog height

- (1) Lean the machine head backward.
- (2) Turn the pulley by hand and stop it at the position where the feed dog rises to the maximum height.
- (3) Loosen the feed bar screw.
- (4) Vertically move the feed bar (in the direction indicated by the arrow in the figure) to adjust it to an adequate height.
- (5) After adjusting, tighten the feed bar screw.

The feed dog height is factory-adjusted to 1.0 mm.

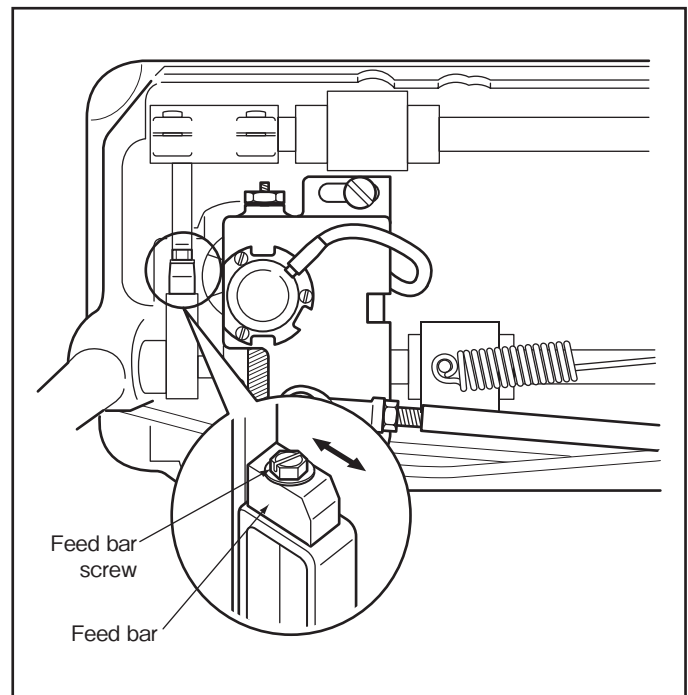
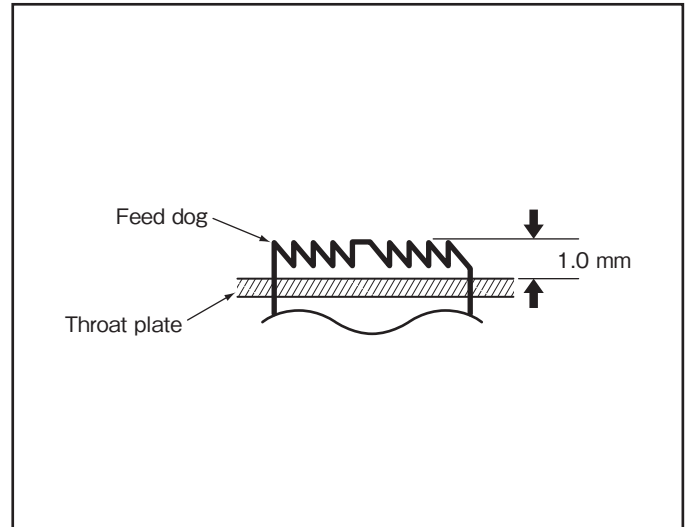

HOW TO USE

20 Relationship between the rotating hook motion and the thread take-up lever motion

When the timing belt is removed for replacement, etc., the relation between the rotating hook motion and the thread take-up lever motion should be adjusted as follows:

- (1) Turn the pulley and stop when the thread take-up lever is lifted to the highest position.
- (2) Lean the machine head backward and check that the arrow (timing mark) put on the timing belt is aligned with the black line on the boss of lower shaft bearing.
- (3) If the timing mark is not in line with the black line, remove the timing belt and install it again to adjust.

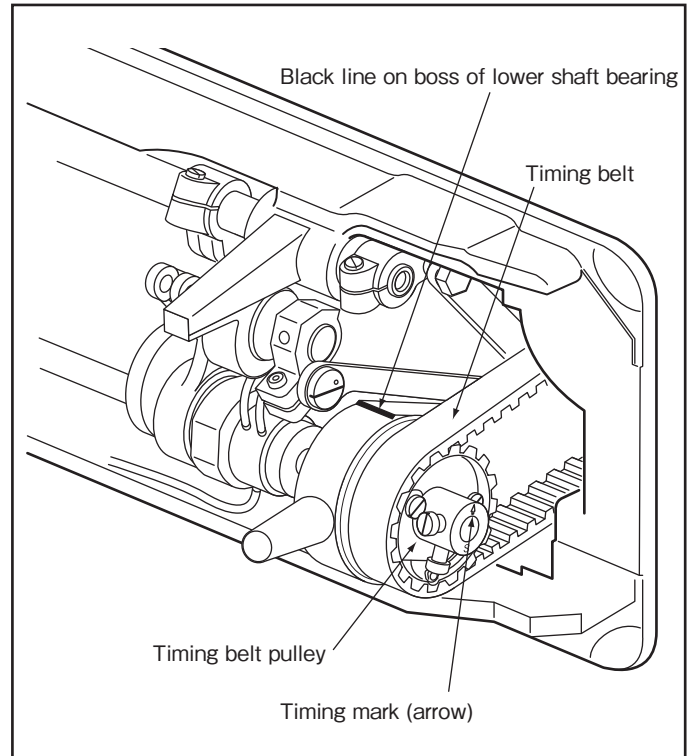

21 Relationship between the rotating hook motion and the opener motion

- (1) Turn the pulley by your hand and stop it at the position where the opener holder is located most remotely from the throat plate.
- (2) Check that the gap between the lug (A) and the opener is approximately 0.2 mm.
- (3) If the gap is too large or small, loosen the opener holder screw (B) and adjust position of the opener.

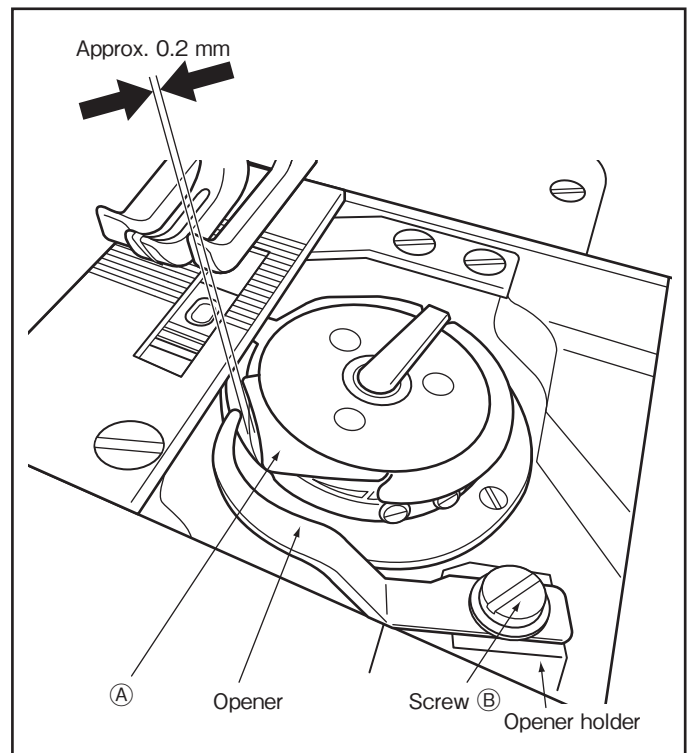

HOW TO USE

22 Relationship between the needle motion and the feed dog motion

- (1) Set the stitch length to "0" on the feed length setting dial.
- (2) Set the needle at the lowest position.
- (3) Lean the machine head backward.
- (4) Loosen the feed rock shaft crank set screws ①, ②.
- (5) Adjust the distance between the pressure bar and the vibrating prevention bar to 9.2 mm and fully tighten the feed rock shaft crank set screws ①, ②.

At this time, check that the needle enters the hole at center of the feed dog.

Note: Be careful not to touch the feed rock shaft crank (right) and the bed together.

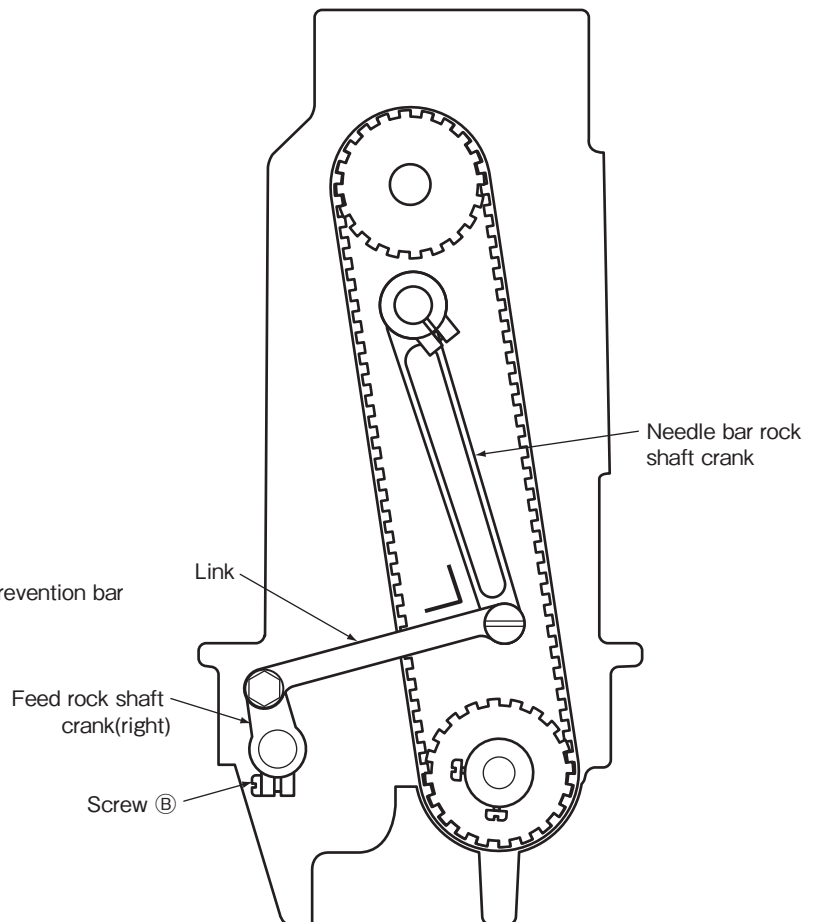
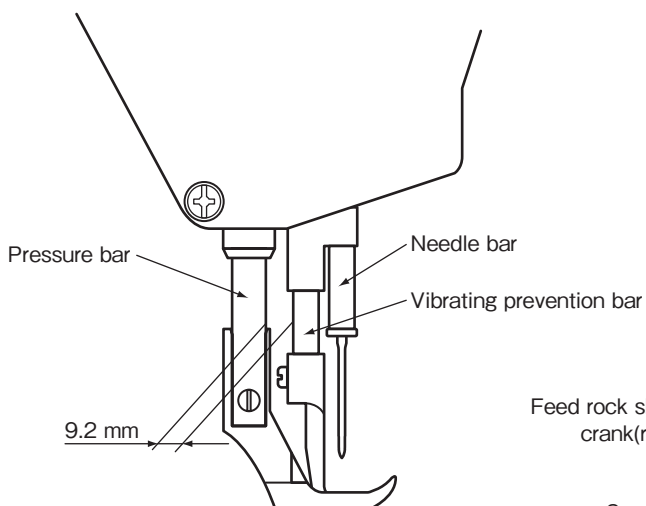
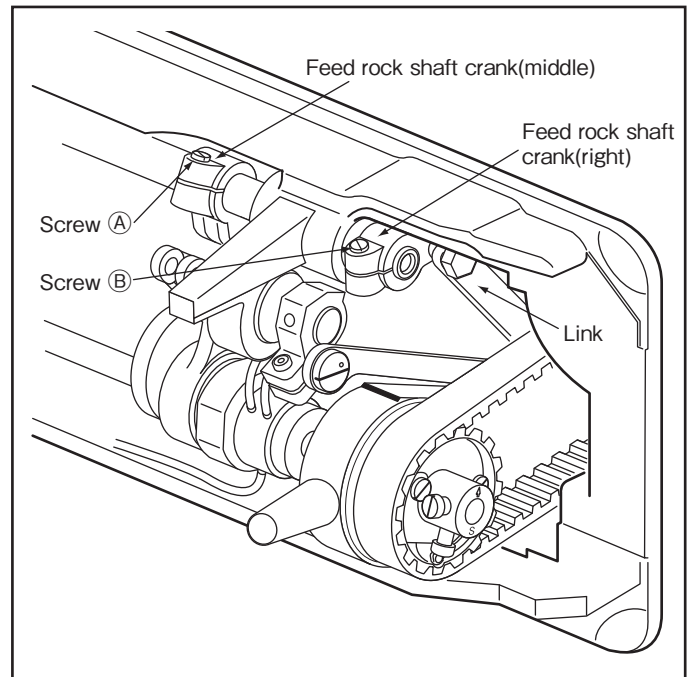

HOW TO USE

23 Safety clutch

● A safety clutch is installed to prevent the hook or timing belt damage if the thread is caught in the hook when the machine is loaded abnormally during operation.

1) Function of the safety clutch

- (1) When the safety clutch functions, the timing belt pulley will be freed, and the lower shaft rotation will stop. The upper shaft only will rotate. Stop the operation of the machine.
- (2) Completely remove the thread, etc. caught in the hook.
- (3) Turn the bushing by hand, and check whether the lower shaft rotates lightly and properly, then install the clutch device as before.

2) How to set safety clutch

- (1) While pushing down the pushbutton on the opposite side of bed with your left hand, turn the pulley slowly with your right hand away from you as shown in the figure.
- (2) The pulley will be stopped by the gear plate, but turn the pulley more firmly.
- (3) Release the pushbutton.
- (4) The clutch device will be set as shown in the figure.

3) Force applied to the safety clutch

- (1) The force applied to the safety clutch is the smallest when the white mark of the eccentric pin faces the center of the lower shaft. The force proportionally increases as the white mark faces the outside.
- (2) To adjust the force, slide the timing belt, loosen the set screw, and turn the eccentric pin.
- (3) After adjusting, fully tighten the set screw.

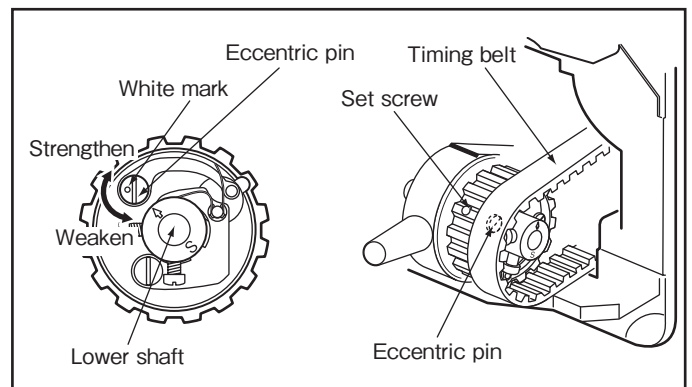
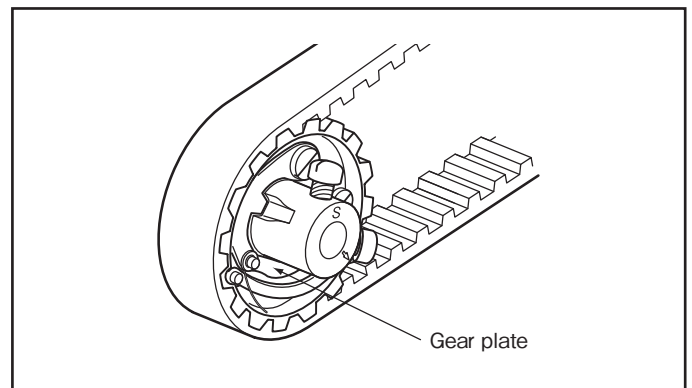
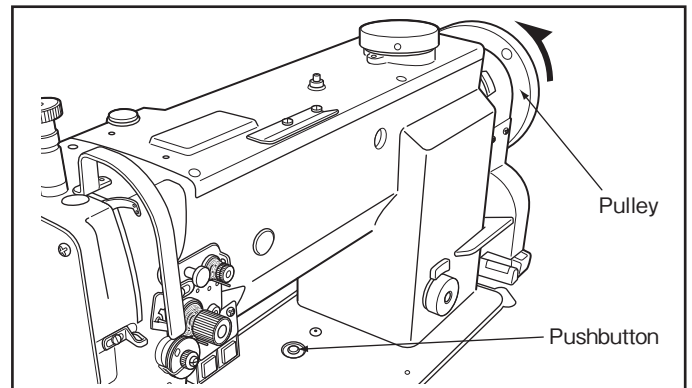
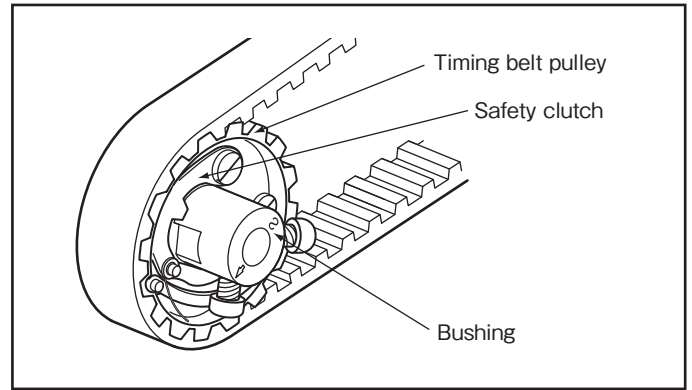

HOW TO USE

24 Adjustment of upper feed length (needle side)

If uneven feeding occurs according to the fabric, adjust the long hole of the feed rock shaft crank (right) to adjust the upper feed length.

(How to adjust)

- (1) Loosen the special bolt.
- (2) Move the special bolt upward to decrease the upper feed.
- (3) Move the special bolt downward to increase the upper feed. (The upper feed and the lower feed theoretically become equal when the center of the special bolt matches the reference line of the feed rock shaft crank)
- (4) After adjusting, tighten the special bolt.

Note: If the special bolt is overtightened, the link and the feed rock shaft crank (right) may not work.

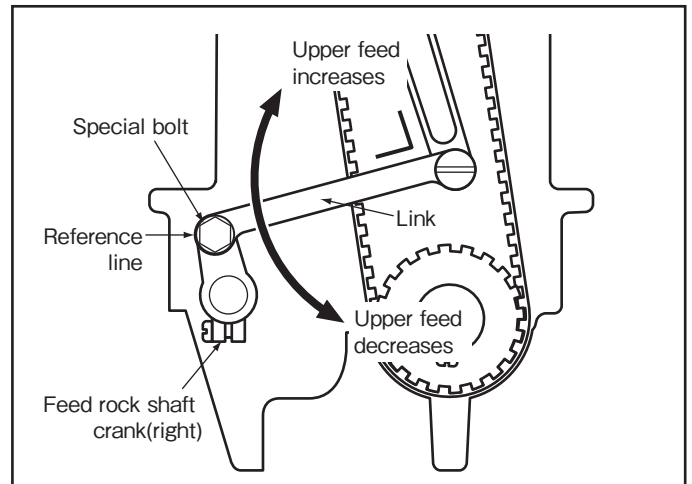

25 Adjustment of forward/backward feed length

The forward/backward feed length can be adjusted by moving the eccentric pin as shown in the figure.

- (1) Loosen the reverse stitch shaft crank screw.
- (2) To increase forward stitch length, turn the eccentric pin clockwise.
To increase backward stitch length, turn the eccentric pin counterclockwise.

Note: Please adjust in the range where the mark point of the eccentric pin is facing to the reverse block side as shown in the figure.

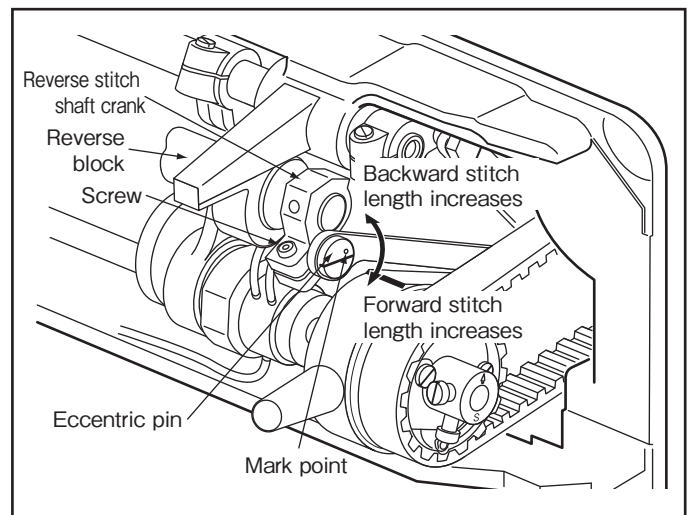

26 Installation of the movable knife

1. Initial position of the movable knife

- (1) Turn the pulley and stop it at the position where the needle comes to the lowest.
- (2) Put the cam roller into the thread trimmer cam groove by pushing the cam follower crank.
- (3) In this condition, turn the pulley and stop it at the position where the black mark point on the arm meets the white mark point on the pulley.

Set the cam follower crank at this position with a screwdriver temporarily preventing the cam roller coming out from the cam groove.

- (4) Loosen bolt (A).
- (5) Adjust so that the tip of the movable knife is hidden 0 to 0.5 mm in the fixed knife, as shown in the figure and tighten bolt (A).

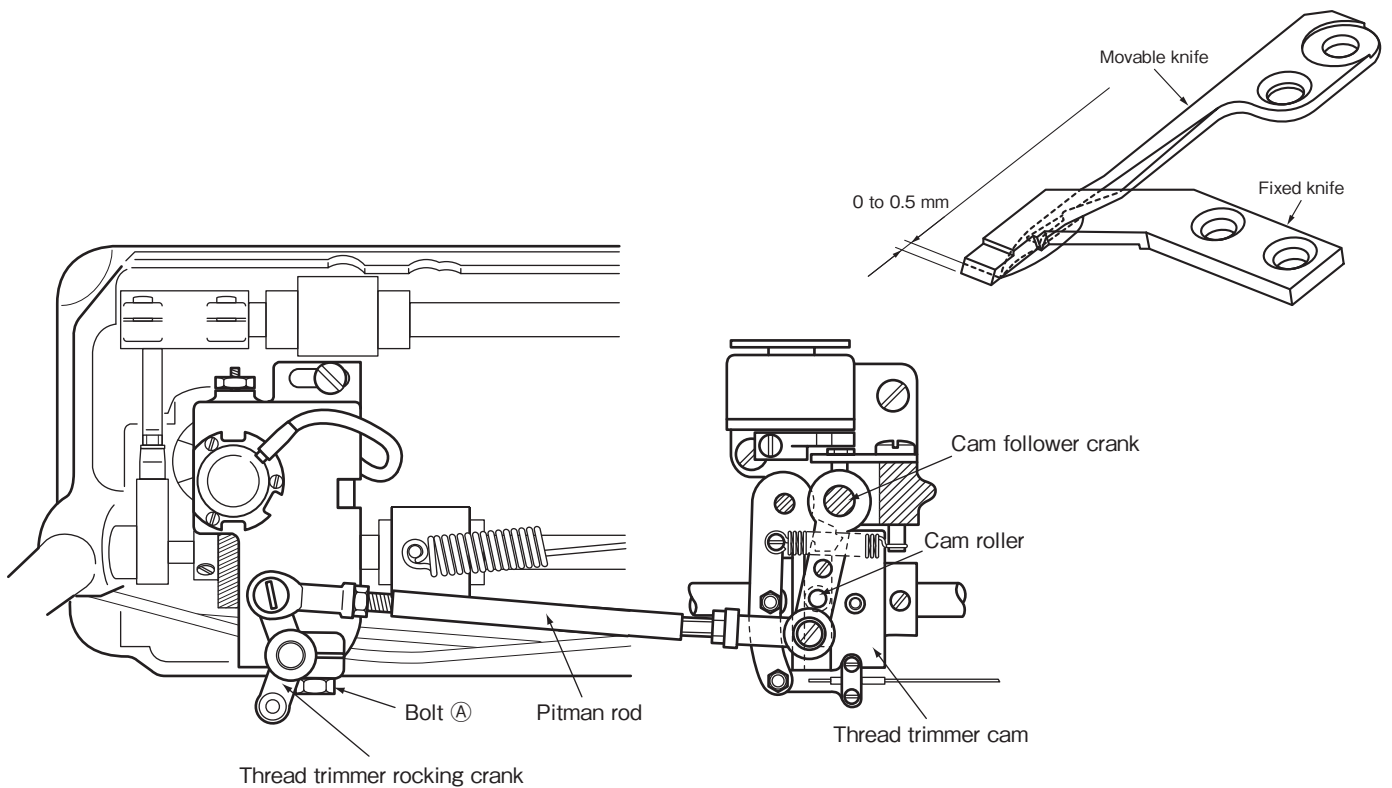

2. Gap between the movable knife and the lug of inner hook

- (1) Turn the pulley and stop it at the position where the needle comes to the lowest.
- (2) While pushing the cam follower crank, turn the pulley and stop it at the position where the movable knife move to the position as shown in the figure.
- (3) Turn the inner hook and adjust so that the gap between the movable knife and the lug of inner hook is about 0.5 mm (screws (A) and (B) should be loosened for this adjustment).

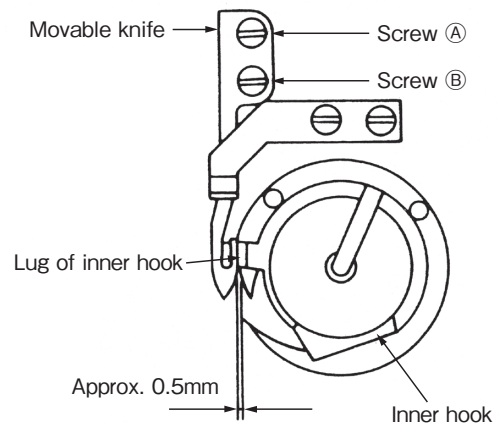

HOW TO USE

27 Installation position of the thread trimmer cam

- (1) Adjust so that the gap between the feed cam and the bushing is 17.3 mm and then tighten the screw ① to the flat on the lower shaft.
- (2) Place the thread trimmer cam on the end face of the bushing and the thread tension releasing cam on the end face of the thread trimmer cam (making the gap between each part zero), then tighten each screw.

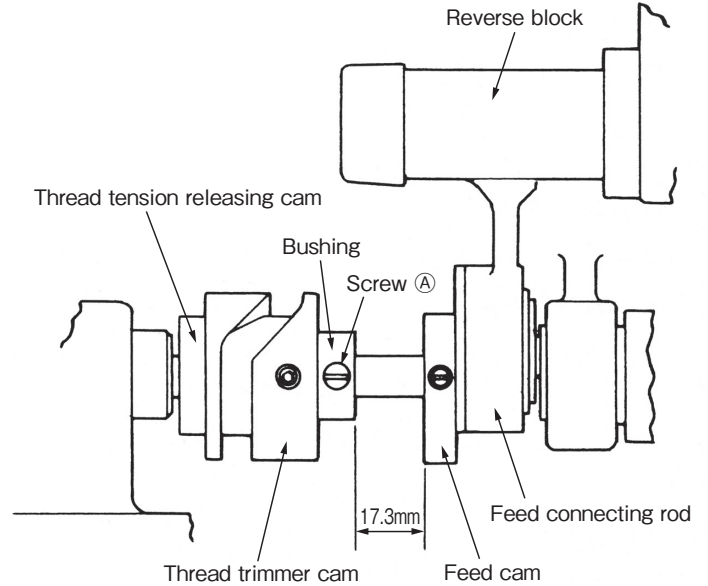

28 Adjustment of the thread trimmer cam

- (1) Turn the pulley and stop it at the position where the needle comes to the lowest.
 - (2) Put the cam roller into the thread trimmer cam groove by pushing the cam follower crank.
 - (3) Turning the pulley, adjust the thread trimmer cam so that the movable knife starts moving when the green mark point on the pulley comes in line with the black mark point on the arm.
- To adjust, loosen two thread trimmer cam clamp screws ①.

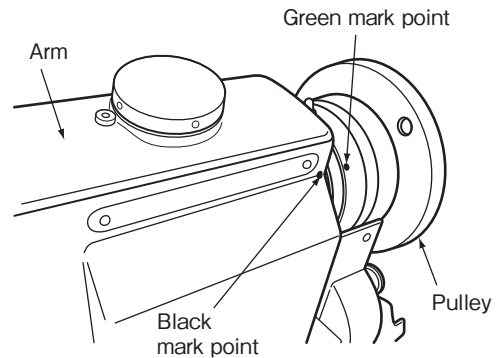
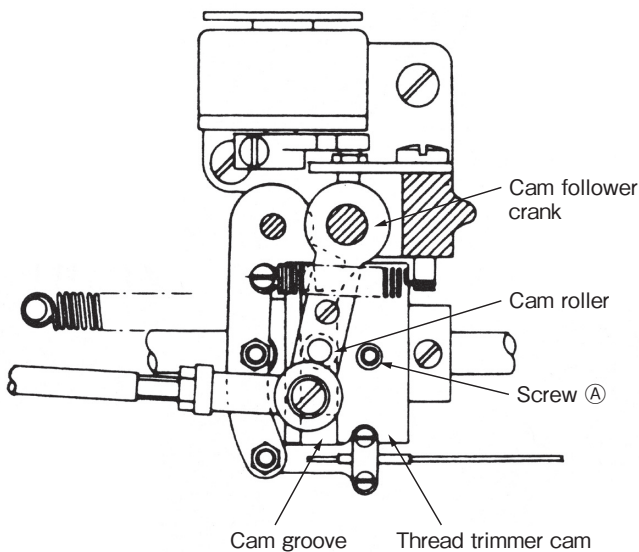

29 Adjustment of the thread tension releasing

- (1) Turn the pulley and stop it at the position where the needle comes to the lowest.
- (2) Put the cam roller into the thread trimmer cam groove by pushing the cam follower crank.
- (3) Turning the pulley, adjust the thread tension releasing cam so that the thread tension disc closes when the white mark point on the pulley comes in line with the black mark point on the arm.
To adjust, loosen two thread tension releasing cam clamp screws ①.
- (4) The opening amount of the thread tension disc should be adjusted with the thread tension releasing roller ② mounted on the convex portion of the thread tension releasing cam, as shown in the figure.
To adjust, loosen screws ③ and pull the wire.
- (5) Make fine adjustments by loosening the nut ④.
- (6) Loosen the nut ④ and make the outer casing approach to the right to increase the opening amount.

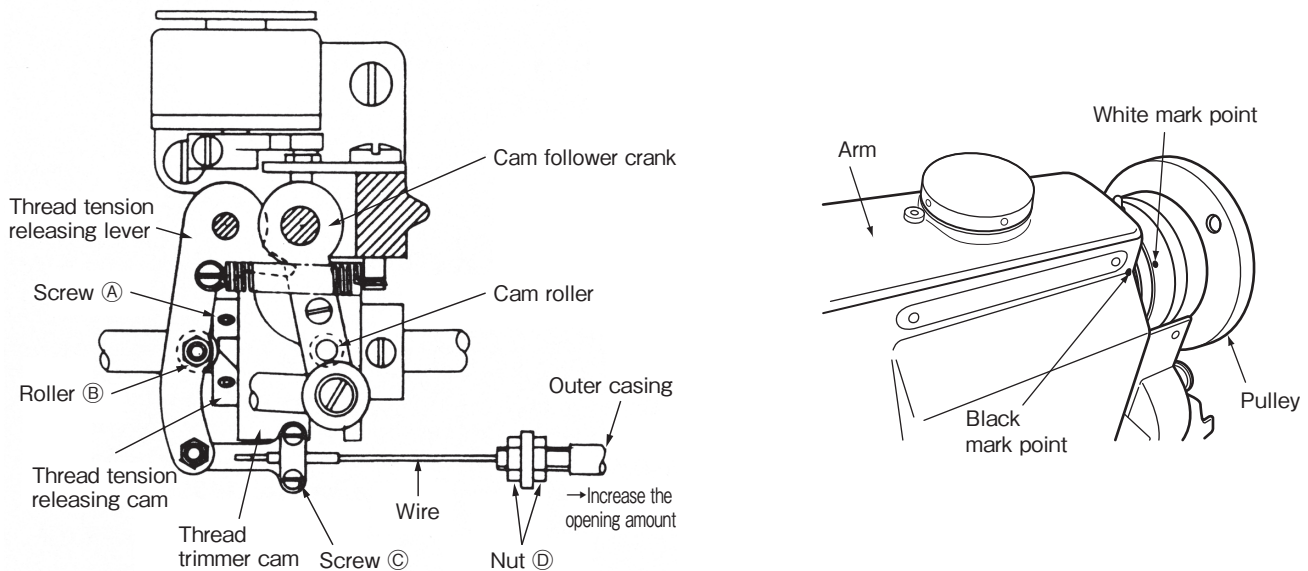

HOW TO USE

30 Adjustment of meshing pressure between the movable knife and the fixed knife

- (1) Loosen the fixed knife bracket clamp bolt (A).
- (2) Adjust meshing pressure by turning the up and down adjusting screw (B), and tighten the bolt (A).

Note: Since overpressure causes a large torque on the thread trimmer mechanism and trimming failure, adjust so that the thread can be trimmed with the minimum pressure.

- (3) Move the movable knife and check that the thread can be sharply trimmed.

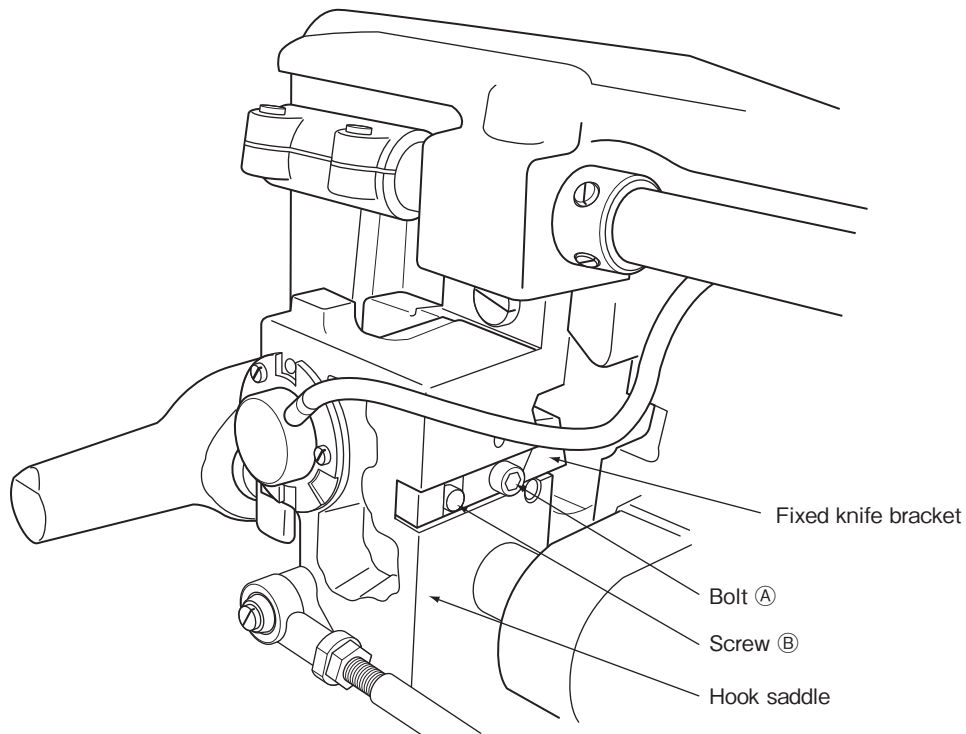

31 Sharpening of the fixed knife

If the fixed knife is dull, it should be sharpened as shown in the figure.

Since it is very difficult to sharpen the movable knife, replace it with a new one when it dulls.

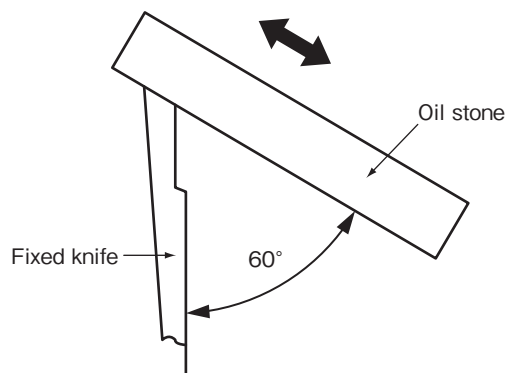

SPECIFICATIONS

LU2-4652-B1T Specifications

| | | | |
|----------------------------------|--------------------|-------------------------------------|---------------|
| Model | | LU2-4652-B1T | |
| Specifications | | | |
| Number of needles | | Single-Needle | |
| Application | | Heavy material | |
| Max. sewing speed | (rpm) | Alternating movement | Stitch length |
| | 3000 | 2 | 0 to 6 |
| | 2700 | 3 | 0 to 6 |
| | 2000 | 5 to 6 | 6 to 8 |
| Stitch length (mm) | | 0 to 8 | |
| Presser foot stroke (mm) | Hand | 9 | |
| | Knee | 16 | |
| Needle | | DP × 17 #21 | |
| Needle bar stroke (mm) | | 35.0 | |
| Thread take-up lever stroke (mm) | | 71.0 | |
| Alternating | Movement (mm) | 2.0 to 6.0 | |
| | Stroke adjustment | Dial | |
| | Instant adjustment | Air cylinder | |
| Thread trimmer | | ○ | |
| Touch back | | ○ | |
| Hook (horizontal rotating hook) | | Large | |
| Bobbin | | Made of aluminum for thread trimmer | |
| Lubrication system | | Automatic lubrication | |
| Standard air pressure | | 0.4 MPa [4 kgf/cm ²] | |
| Bed dimensions (mm) | | 517 × 178 | |

The maximum sewing speed is fixed automatically according to the alternating up and down stroke. However, it is not fixed automatically to the stitch length. So manually adjust the maximum sewing speed whenever it is required to the stitch length.

Note: ● Feed dog, throat plate, rotating hook, bobbin case, bobbin, and bed slide should be those designed for the thread trimmer.

● The bobbin should be of high quality free from deformation.

● Some materials, and/or sewing conditions may require specifications other than those listed above.

● These specifications are subject to change for machine improvement.

JUKI CORPORATION

Printed in Japan