

# **JUKI®**

LOCKSTITCH COMPOUND FEED  
INDUSTRIAL SEWING MACHINES

**MODEL**

**LU2-4400-B0B** (Single-Needle)

**LU2-4420-B0B** (Double-Needle)

**INSTRUCTION MANUAL**

## INTRODUCTION

Thank you very much for purchasing industrial sewing machine.

Please read this instruction manual before operating the sewing machine. Please read also “Safety Manual”, “Instruction manual for LIMISERVO” and operate the sewing machine correctly and safely.

## PRECAUTION BEFORE STARTING OPERATION

### 1 Safety Precautions

1. When turning the power on, keep your hands and fingers away from the area around/under the needle and the area around the pulley.
2. The power must be turned off when the machine is not used, or when the operator leaves his/her seat.
3. The power must be turned off before tilting the machine head, installing or removing the “V” belt, adjusting the machine, or replacing parts.
4. Avoid placing fingers, hairs, obstacles, etc. near the pulley, “V” belt, bobbin winder wheel, or motor when the machine is in operation. Injury could result.
5. Don't put fingers into the thread take-up lever cover, around/under the needle, or pulley when the machine is in operation.
6. If the belt cover, the finger guard, and/or the eye guard are installed, don't operate the machine without these safety devices.

### 2 Precaution before Starting Operation

1. If the machine's oil pan has an oil sump, never operate the machine without filling oil in it.
2. If the machine is lubricated by a drop oiler, never operate the machine without lubricating.
3. When a new sewing machine is operated, verify the rotational direction of the pulley with the power on.  
(The pulley should rotate counterclockwise when viewed from the pulley.)
4. Verify voltage and (single or three) phase indicated on the nameplate of the motor.

### 3 Precaution for Operating Conditions

1. Avoid using the machine at abnormally high temperature (35°C or higher) or low temperature (5°C or lower). Otherwise, machine failure may result.
2. Avoid using the machine in dusty conditions.
3. Avoid using the machine in conditions filled with a lot of electric noises such as high-frequency welders.

# CONTENTS

<b>USAGE PRECAUTION</b>	1
1 Lubrication (1)	1
2 Lubrication (2)	1
3 Lubrication condition	2
4 Adjustment of lubrication to the rotating hook	2
5 Installation of the belt cover	2
6 Precaution on operation	2
<b>HOW TO USE</b>	3
1 Installation of needles	3
2 Winding of the bobbin thread	3
3 Selection of the thread	4
4 Threading of needle threads	4
5 Adjustment of feed (stitch) length and backstitch	5
6 Setting of bobbins	5
7 Threading of bobbin threads	6
8 Adjustment of bobbin threads tension	6
9 Balance of threads tension	6
10 Adjustment of needle threads tension	6
11 Adjustment of the presser foot pressure	6
12 Timing between the rotating hook motion and the needle motion	7
13 Adjustment of the feed dog height	8
14 Relationship between the rotating hook motion and the thread take-up lever motion	9
15 Relationship between the rotating hook motion and the opener motion	9
16 Relationship between the needle motion and the feed dog motion	10
17 Safety clutch	11
18 Adjustment of upper feed length (needle side)	12
19 Adjustment of forward/backward feed length	12
20 Adjustment of the outside presser foot and the inside presser foot	12
<b>SPECIFICATIONS</b>	14

# USAGE PRECAUTION

## 1 Lubrication (1)

Fill the oil reservoir with oil up to “H” mark.  
Oil level should be periodically checked. If oil level is found below “L” level replenish oil to “H” level.  
For oil, use “MC70M” specified by our company.

※ Refer

MC70M : Specific gravity (15°C ) = 0.86 (g/cm<sup>3</sup>)  
: Viscosity (40°C ) = 10.9 (mm<sup>2</sup>/s)

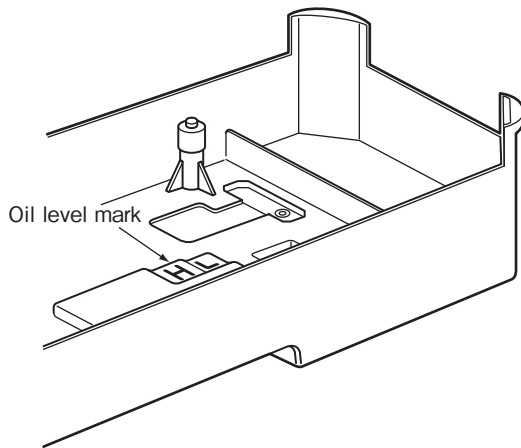

## 2 Lubrication (2)

When a new sewing machine is used for the first time, or sewing machine left out of use for considerably long time is used again, replenish a suitable amount of oil to the portions indicated by arrows in the below figure.

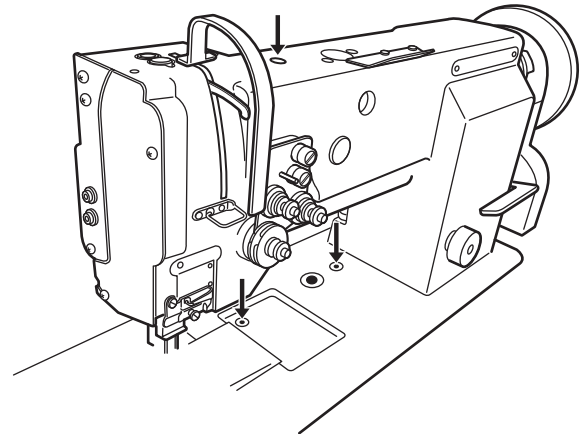
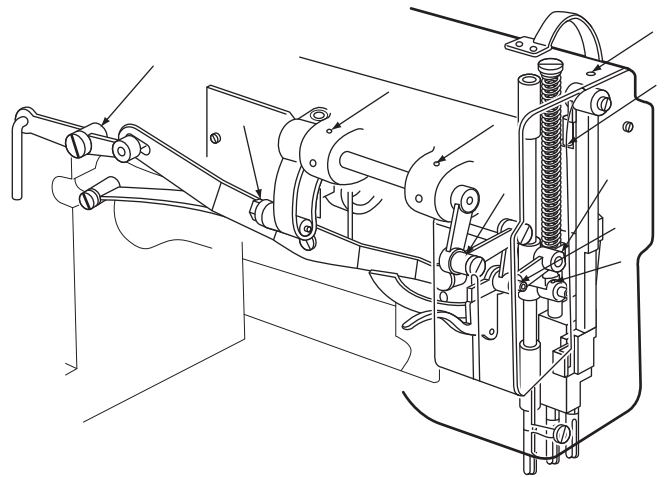

# USAGE PRECAUTION

## 3 Lubrication condition

See dripping of oil through the oil sight window to check oiling condition during operation.

Confirm that oil has been drained from the oil tank when the operation is stopped.

When dust, etc. accumulate in the oil tank, remove the rubber plug to clean.

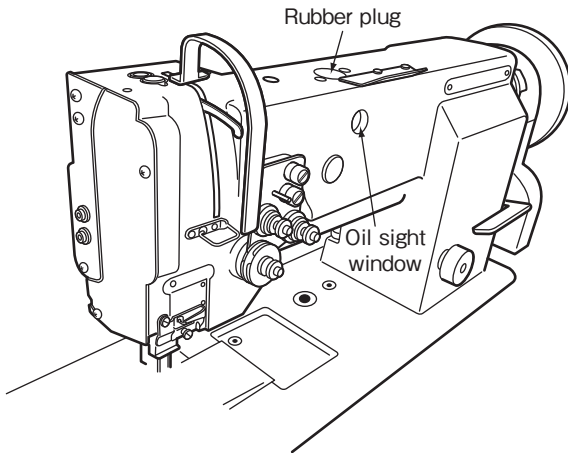

## 4 Adjustment of lubrication to the rotating hook

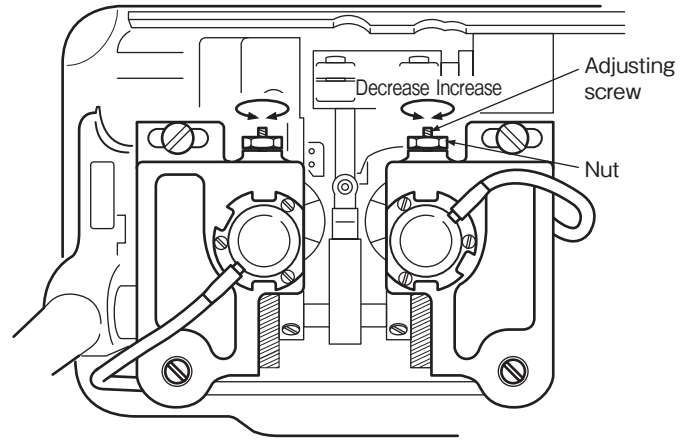

## 5 Installation of the belt cover

1. Install the belt cover on the machine side for safety. Refer to the provided instruction document contained in the same package.
2. Install the belt cover on the motor side for safety.

## 6 Precaution on operation

- (1) When the power is turned on or off, keep foot away from the pedal.
- (2) It should be noted that the brake may not work when the power is interrupted or power failure occurs during sewing machine operation.
- (3) Since dust in the control box might cause malfunction or control troubles, be sure to keep the control box cover close during operation.
- (4) Do not apply a multimeter to the control circuit for checking, otherwise voltage of multimeter might damage semiconductor components in the circuit.

# HOW TO USE

## 1 Installation of needles

Note: Before installing the needles, be sure to turn off the power.

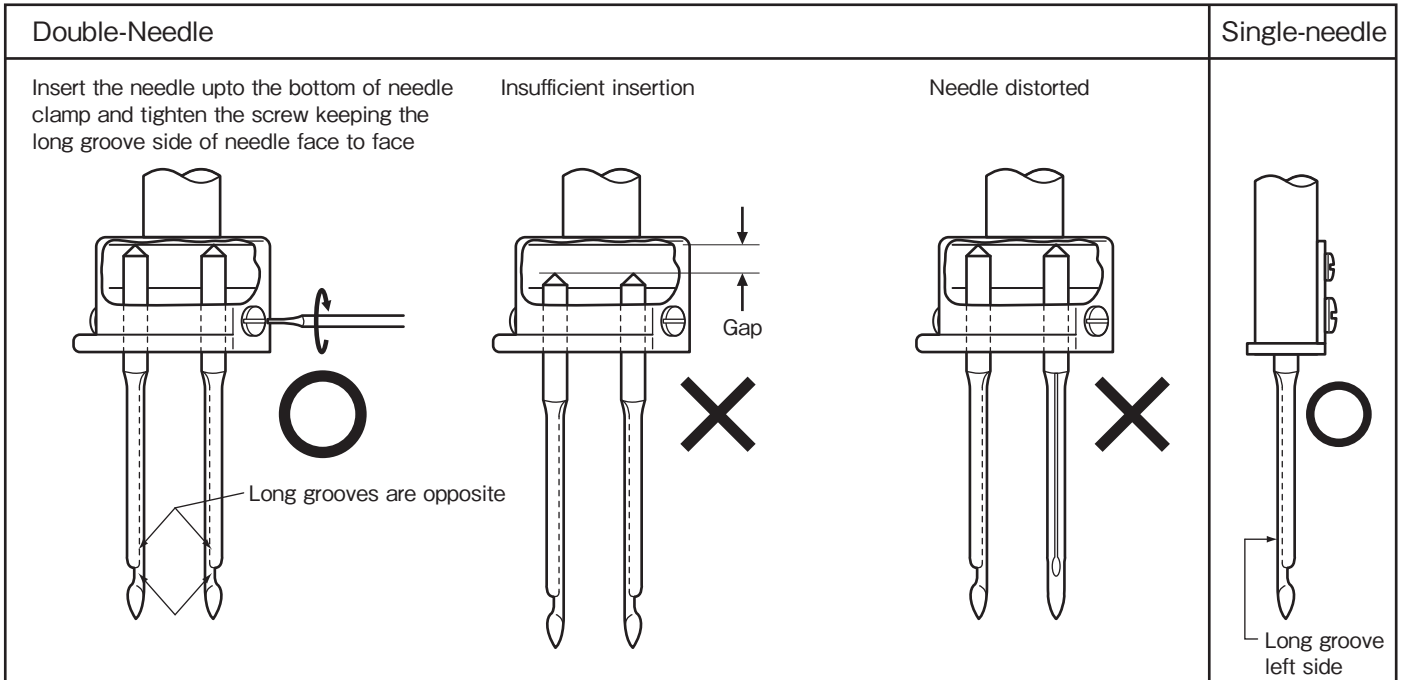

## 2 Winding of the bobbin thread

Note: When bobbin thread is wound, keep the presser foot lifted.

- Adjustment**
- **Tension of wound thread** Slack winding is recommended for polyester thread and nylon thread.
  - **Conically wound thread** Move the thread guide toward smaller diameter of wound thread layer.
  - **Amount of wound thread** Loosen the winding amount adjustment screw to decrease thread winding amount and tighten the screw to increase thread winding amount.

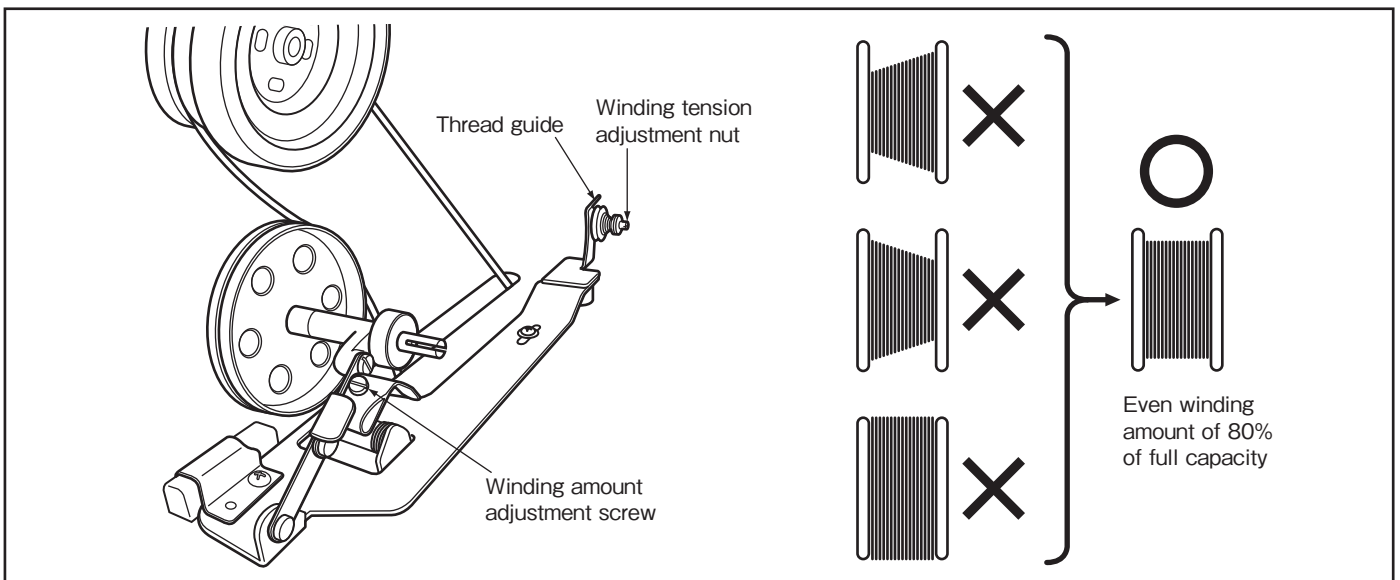

# HOW TO USE

## 3 Selection of the thread

It is recommended to use “S” twist thread in the left needle (viewed from front), and “Z” twist thread in the right needle.

When discriminate use of needle threads is impossible, use “Z” twist thread in both the needles.

For bobbin thread, “S” twist thread as well as “Z” twist thread can be used.

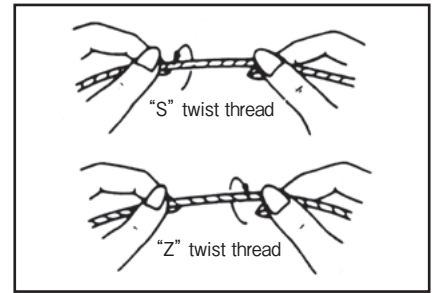

## 4 Threading of needle threads

1. Pass each needle thread through thread guide (A).  
 Note: When thin slippery thread (polyester thread or filament thread, etc.) is used,  
 Pass the thread through thread guide (B) as well.
2. With the thread take-up lever located at the upper most position, pass each needle thread in the order shown in the following figure.

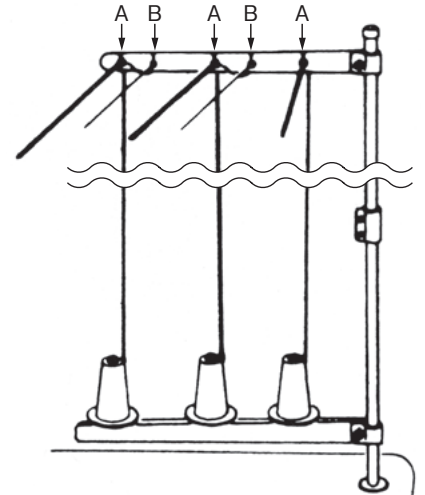

LU2-4420 (LU2-4400 : refer to the only left thread)

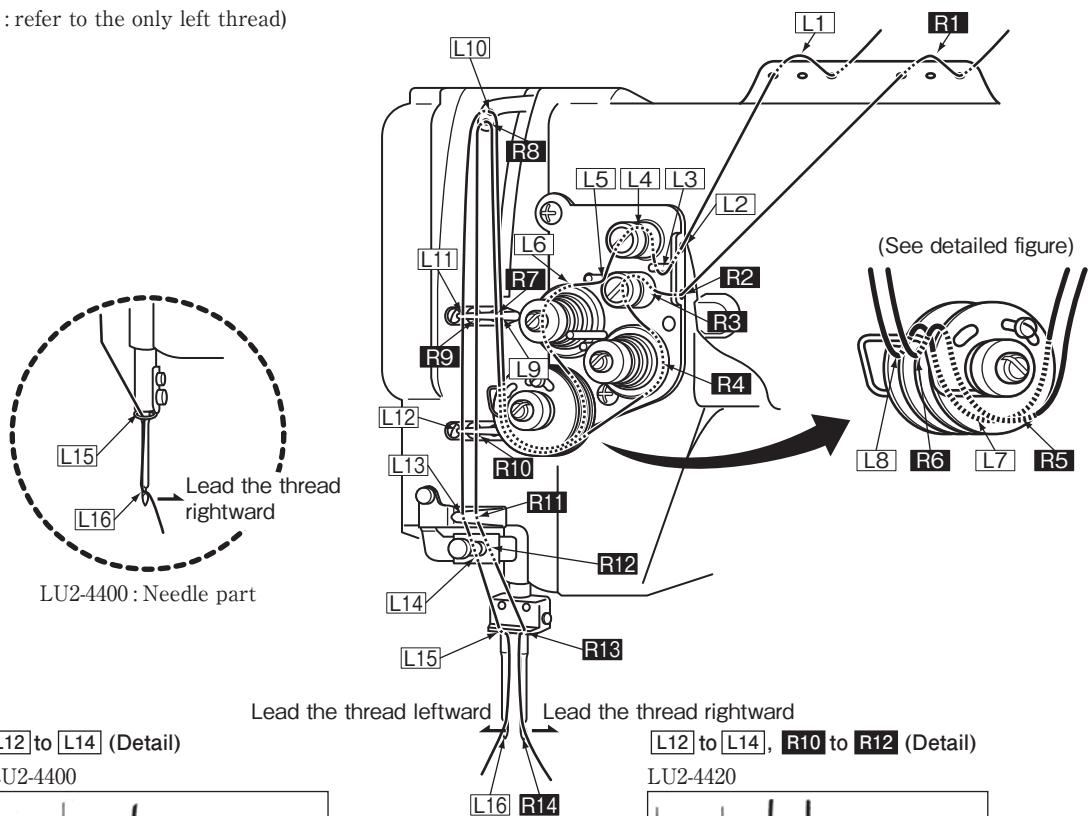

LU2-4400 : Needle part

L12 to L14 (Detail)  
LU2-4400

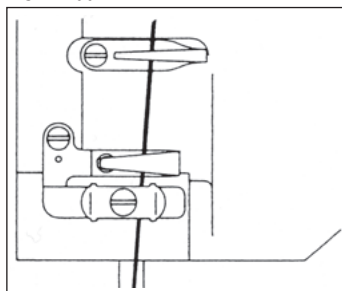

L12 to L14, R10 to R12 (Detail)  
LU2-4420

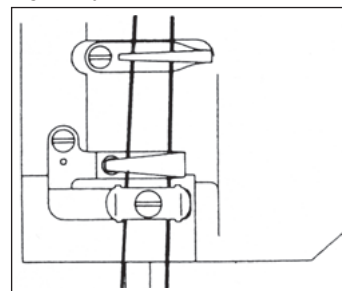

# HOW TO USE

## 5 Adjustment of feed (stitch) length and backstitch

- Adjustment of feed (stitch) length... Adjust feed length by turning the feed length setting dial while depressing the reverse sewing lever.
- Backstitch... Direction of stitching can be reversed by depressing the reverse sewing lever.

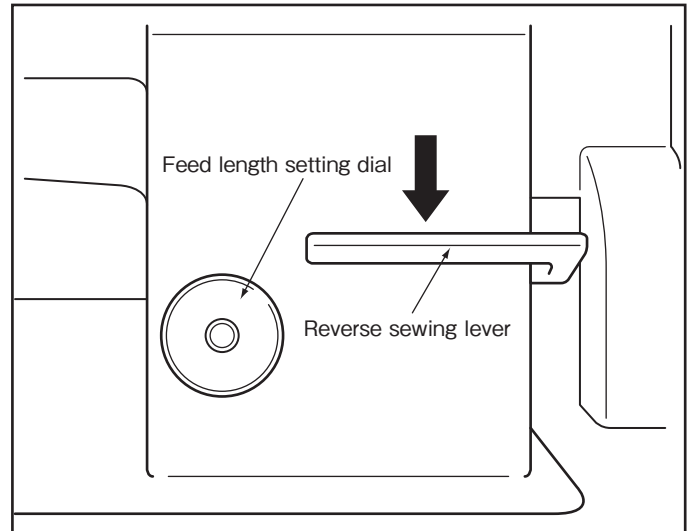

## 6 Setting of bobbins

- (1) Pull out 5cm thread tail from bobbins.
- (2) Put bobbins into hooks in the direction as the following figure.

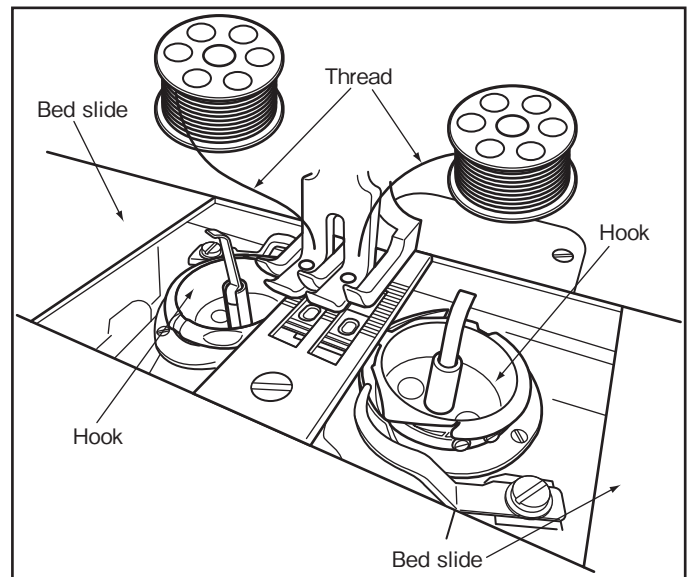



# HOW TO USE

## 7 Threading of bobbin threads

(1) Put bobbin thread into the slit ①, pass under the lug ② and extend it above the bed.

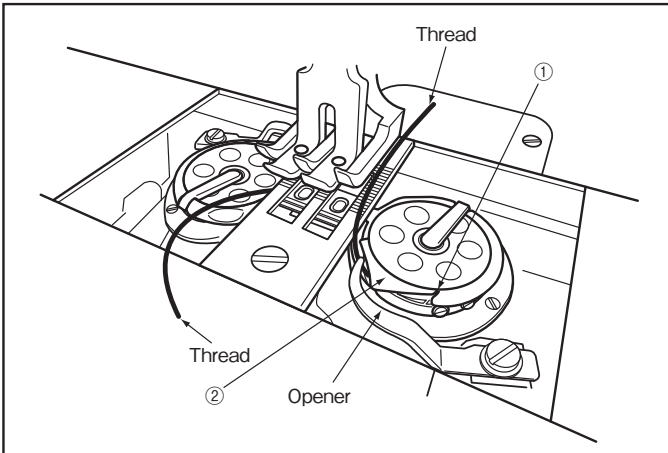

(2) While holding two needle threads with your left hand, turn the pulley one rotation with your right hand. The bobbin threads will come up when needle threads are lifted up as shown in the figure. Needle threads and bobbin threads should be aligned and led backward together.

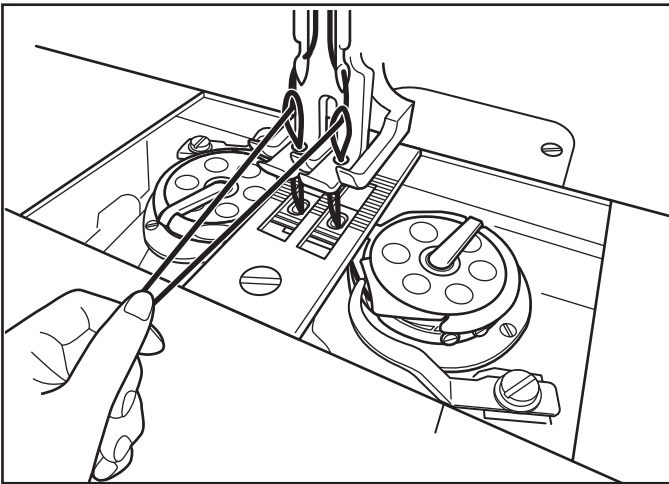

## 8 Adjustment of bobbin threads tension

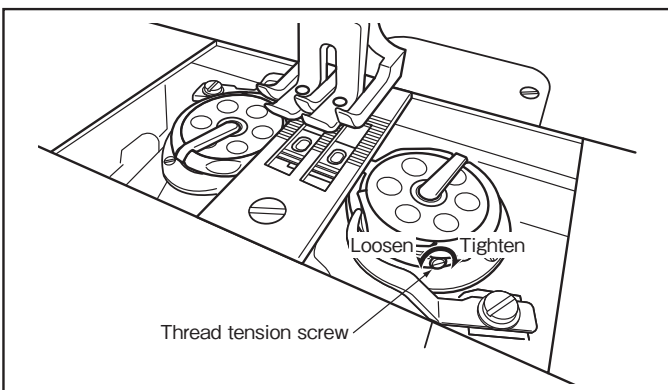

## 9 Balance of threads tension

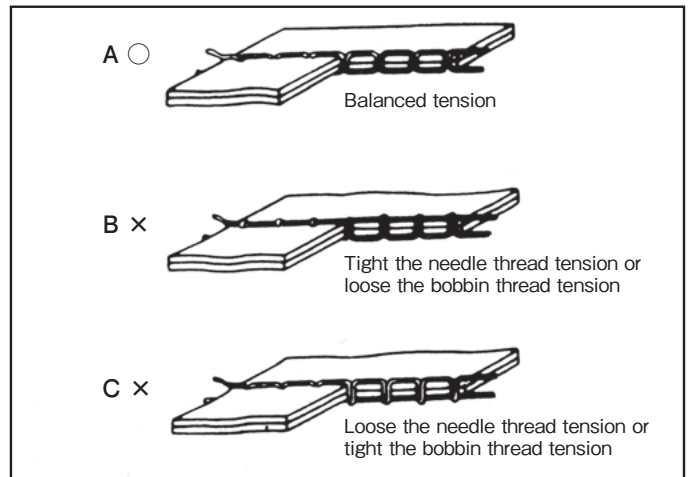

## 10 Adjustment of needle threads tension

- Needle threads tension should be adjusted on the basis of bobbin threads tension.
- Adjust needle threads tension by turning thread tension nuts.

Needle threads tension can be also adjusted by changing intensity and movable range of the thread take-up spring in case of sewing the special fabric and thread.

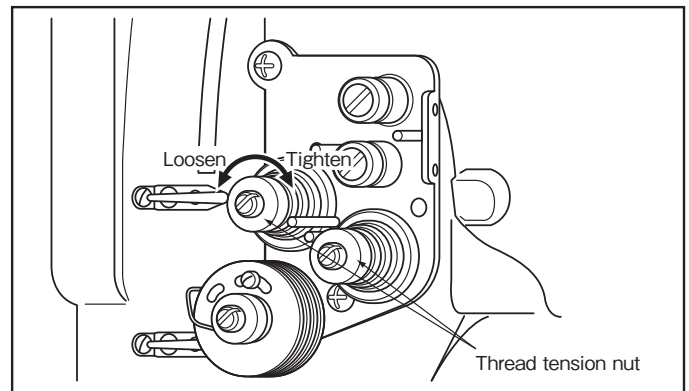

## 11 Adjustment of the presser foot pressure

Adjust the presser foot pressure according to the fabric by turning the pressure adjusting screw.

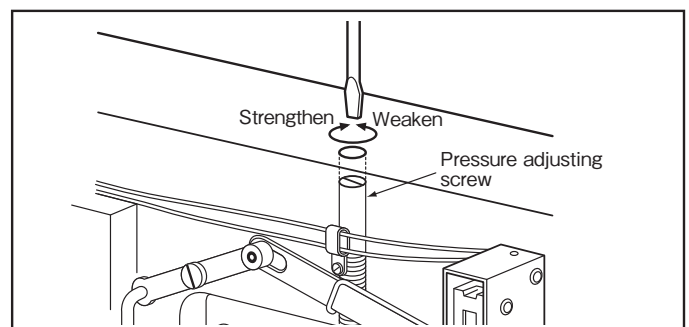

# HOW TO USE

## 12 Timing between the rotating hook motion and the needle motion

In case of double-needle, adjust right and left timing in the same way at the same time.

Note: If you remove the presser foot, the throat plate, and the feed dog, it makes easier to adjust.

- (1) Set feed length to 6mm.
- (2) Loosen all screws ①, ②, ③.

Note: Be careful not to disengage the large gear and the small gear.

- (3) Lift the needle bar 2.4mm from the lowest position. Refer to timing marks shown in the figure.
- (4) Slide the hook saddle right and left so that the gap between the tip of the hook and the scarf of the needle is 0.05mm or lower.
- (5) Tighten screws ①, ②.

Note: Be careful not to overtighten screws ②.

- (6) Slide the large gear right and left so that the tip of the hook position is in the center of the needle and tighten screws ③.

Note: Check the large gear and the hook saddle isn't in contact and its distance is less than 3mm.

- (7) Move the tip of the hook to the needle side by turning the pulley.
- (8) Return the machine head to the original position and adjust the needle guide position so that it come lightly in contact with the needle.

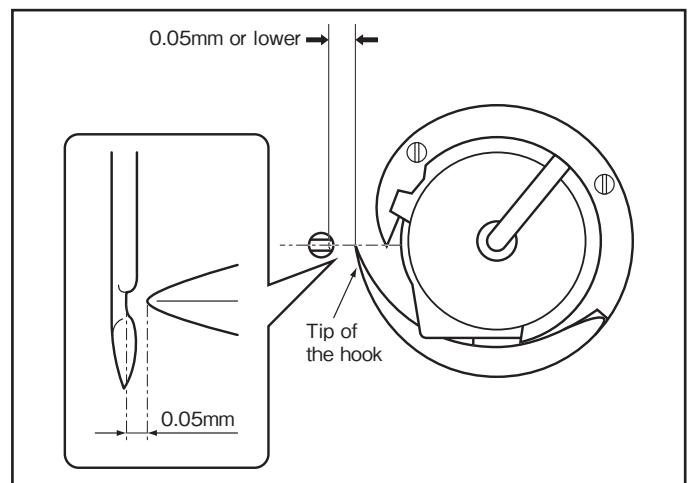
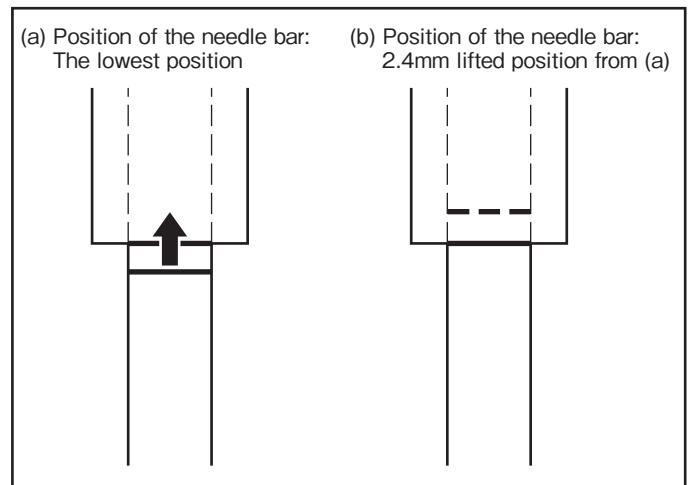
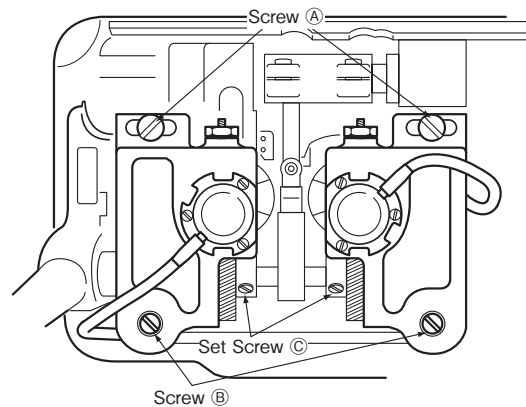

# HOW TO USE

## 13 Adjustment of the feed dog height

The feed dog height and the presser foot pressure must be adjusted according to the fabric.

- ◆ The fabric will be damaged if the feed dog extends too high, or if the presser foot pressure is too large.
- ◆ An even stitch length cannot be assured if the feed dog is too low, or if the presser foot pressure is too small.
- ◆ The feed dog height is the position where the needle is at the top position.

### Adjustment of the feed dog height

- (1) Lean the machine head backward.
- (2) Turn the pulley by hand and stop it at the position where the feed dog rises to the maximum height.
- (3) Loosen the feed bar screw.
- (4) Vertically move the feed bar (in the direction indicated by the arrow in the figure) to adjust it to an adequate height.
- (5) After adjusting, tighten the feed bar screw.

The feed dog height is factory-adjusted to 1.2mm.

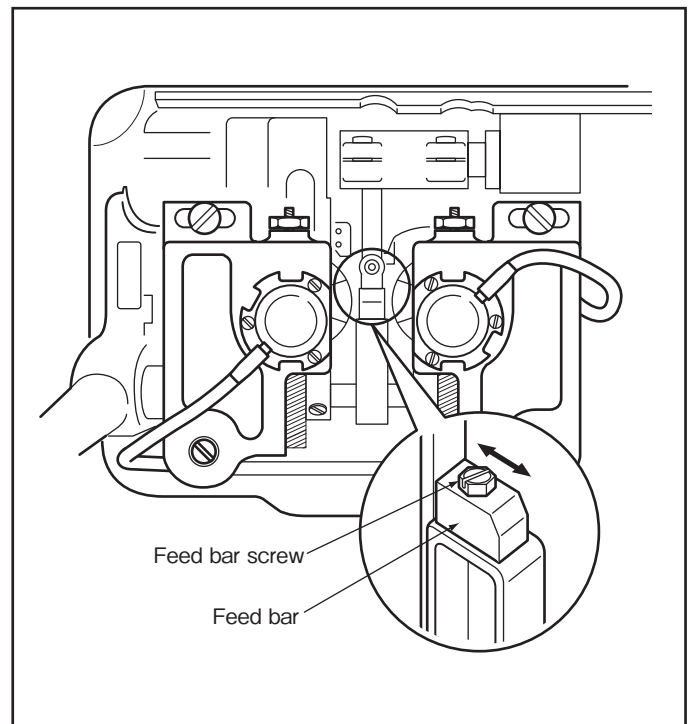
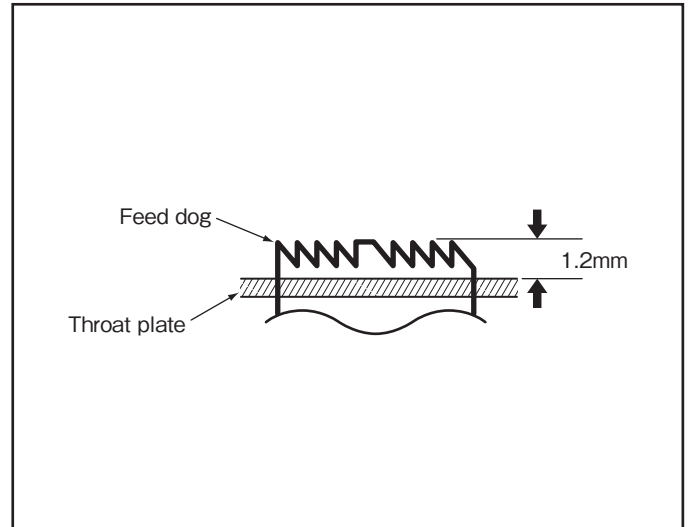

## HOW TO USE

### 14 Relationship between the rotating hook motion and the thread take-up lever motion

When the timing belt is removed for replacement, etc., the relation between the rotating hook motion and the thread take-up lever motion should be adjusted as follows:

- (1) Turn the pulley and stop when the thread take-up lever is lifted to the highest position.
- (2) Lean the machine head backward and check that the arrow (timing mark) put on the timing belt is aligned with the black line on the boss of lower shaft bearing.
- (3) If the timing mark is not in line with the black line, remove the timing belt and install it again to adjust.

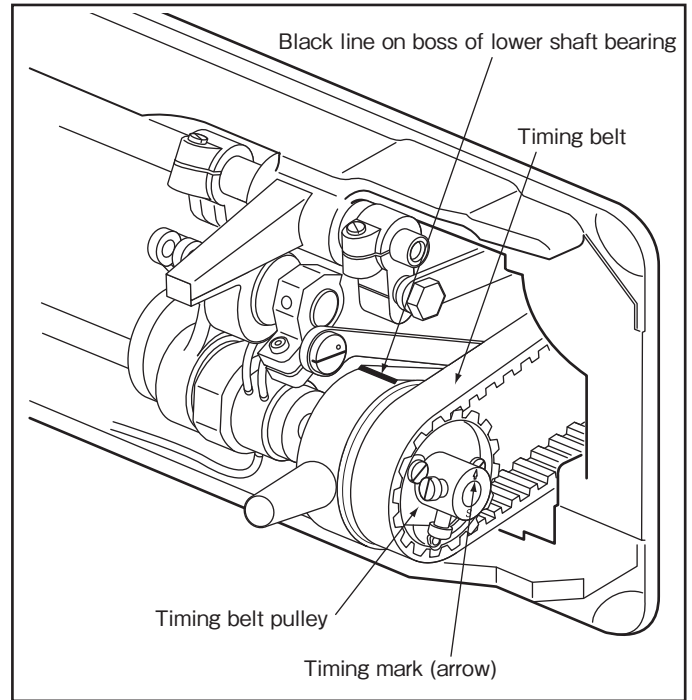

### 15 Relationship between the rotating hook motion and the opener motion

- (1) Turn the pulley by your hand and stop it at the position where the opener holder is located most remotely from the throat plate.
- (2) Check that the gap between the lug **A** and the opener is approximately 0.2mm.
- (3) If the gap is too large or small, loosen the opener holder screw **B** and adjust position of the opener.

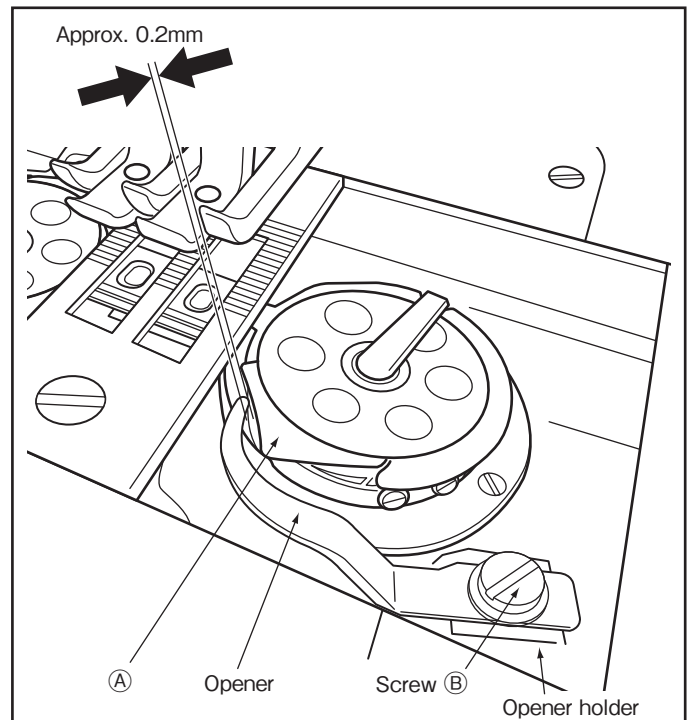

# HOW TO USE

## 16 Relationship between the needle motion and the feed dog motion

- (1) Set the stitch length to "0" on the feed length setting dial.
- (2) Set the needle at the lowest position.
- (3) Lean the machine head backward.
- (4) Loosen the feed rock shaft crank set screws (A), (B).
- (5) Adjust the distance between the pressure bar and the vibrating prevention bar to 9mm and temporary tighten the feed rock shaft crank set screws (A), (B).
- (6) Check that the feed rock shaft crank (right) is connected with the link at a right angle as shown in the figure.
- (7) If the connection is not a right angle, remove the Rear cover, loosen screw (C) and move the link to connect the feed rock shaft crank (right) with the link at a right angle.
- (8) After adjusting, fully tighten all screws (A), (B), (C).

At this time, check that the needle enters the hole at center of the feed dog.

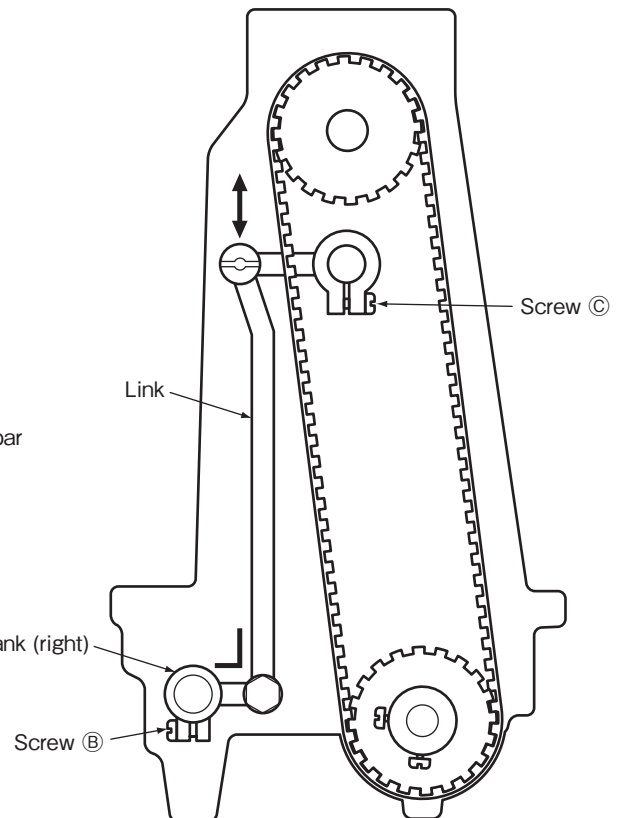
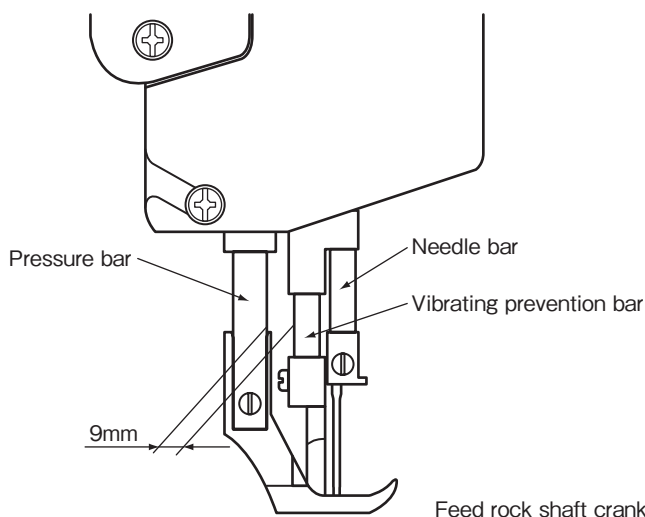
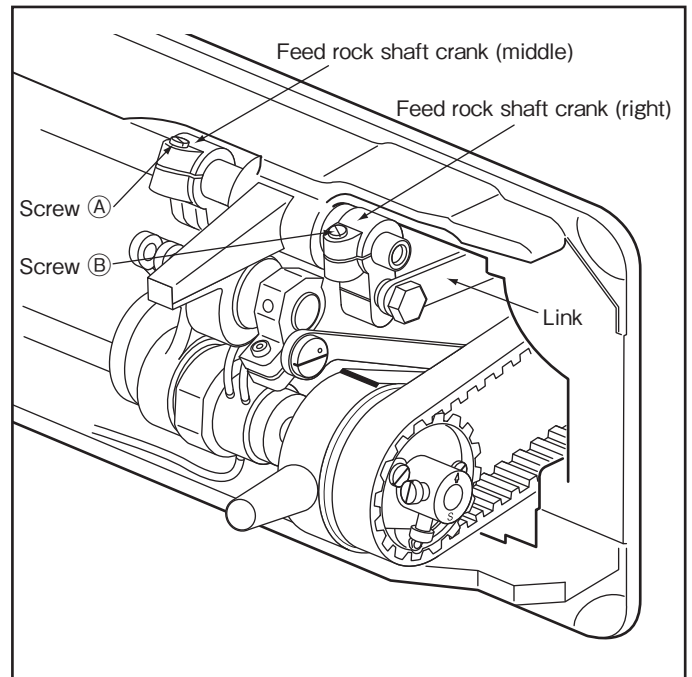

# HOW TO USE

## 17 Safety clutch

● A safety clutch is installed to prevent the hook or timing belt damage if the thread is caught in the hook when the machine is loaded abnormally during operation.

### 1) Function of the safety clutch

- (1) When the safety clutch functions, the timing belt pulley will be freed, and the lower shaft rotation will stop. The upper shaft only will rotate. Stop the operation of the machine.
- (2) Completely remove the thread, etc. caught in the hook.
- (3) Turn the bushing by hand, and check whether the lower shaft rotates lightly and properly, then install the clutch device as before.

### 2) How to set safety clutch

- (1) While pushing down the pushbutton on the opposite side of bed with your left hand, turn the pulley slowly with your right hand away from you as shown in the figure.
- (2) The pulley will be stopped by the gear plate, but turn the pulley more firmly.
- (3) Release the pushbutton.
- (4) The clutch device will be set as shown in the figure.

### 3) Force applied to the safety clutch

- (1) The force applied to the safety clutch is the smallest when the white mark of the eccentric pin faces the center of the lower shaft. The force proportionally increases as the white mark faces the outside.
- (2) To adjust the force, slide the timing belt, loosen the set screw, and turn the eccentric pin.
- (3) After adjusting, fully tighten the set screw.

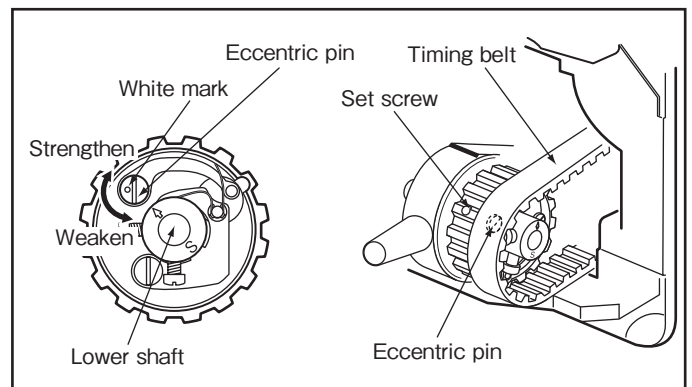
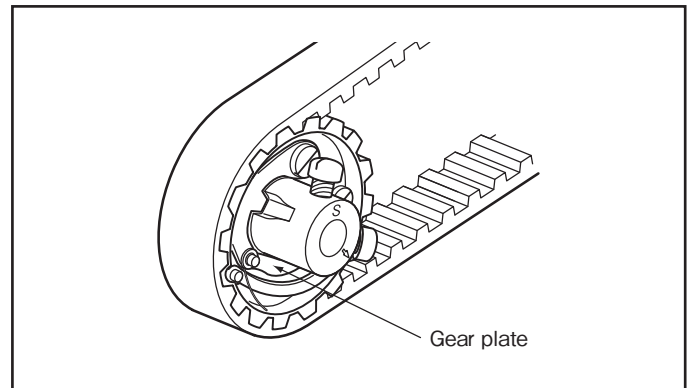
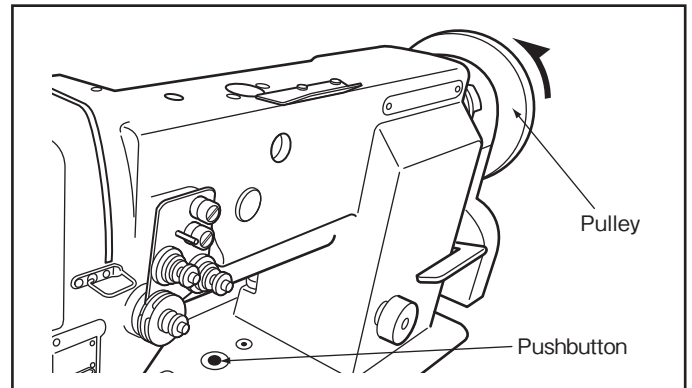
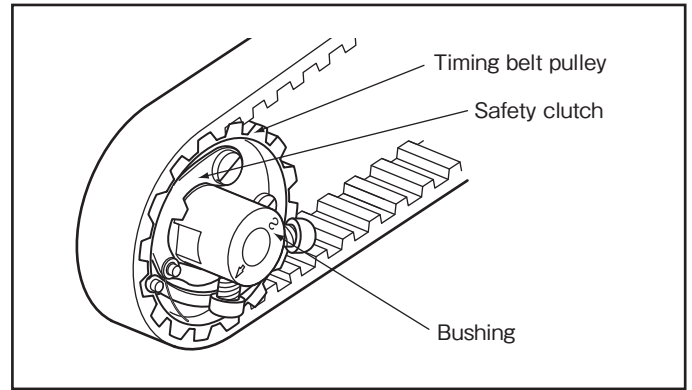

## 18 Adjustment of upper feed length (needle side)

If uneven feeding occurs according to the fabric, adjust the long hole of the feed rock shaft crank (right) to adjust the upper feed length.

### (How to adjust)

- (1) Loosen the special bolt.
- (2) Move the special bolt upward to decrease the upper feed.
- (3) Move the special bolt downward to increase the upper feed. (The upper feed and the lower feed theoretically become equal when the center of the special bolt matches the reference line of the feed rock shaft crank)
- (4) After adjusting, tighten the special bolt.

Note: If the special bolt is overtightened, the link and the feed rock shaft crank (right) may not work.

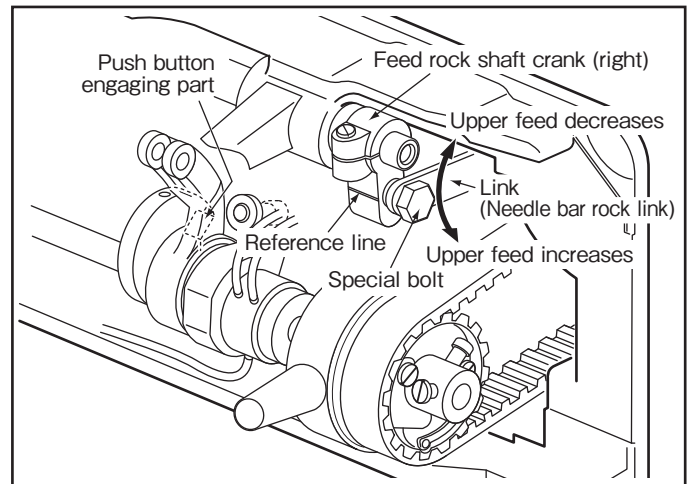

## 19 Adjustment of forward/backward feed length

The forward/backward feed length can be adjusted by moving the eccentric pin as shown in the figure.

- (1) Loosen the reverse stitch shaft crank screw.
- (2) To increase forward stitch length, turn the eccentric pin clockwise.
- To increase backward stitch length, turn the eccentric pin counterclockwise.

Note: Please adjust in the range where the mark point of the eccentric pin is facing to the reverse block side as shown in the figure.

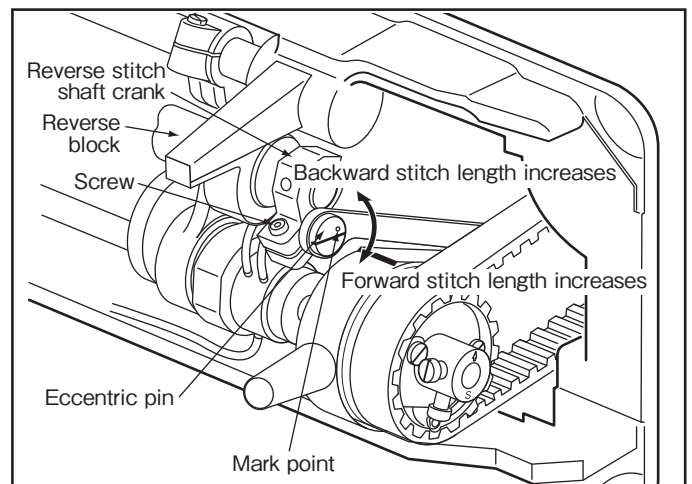

## 20 Adjustment of the outside presser foot and the inside presser foot

### 1. Adjustment of working height of the outside presser foot and the inside presser foot.

Please adjust working height of the presser foot when sewing the fabric having large elasticity or varying the thickness of the fabric.

### (How to adjust)

- (1) Loosen the special bolt.
- (2) Working height is the biggest when the crank rod is moved upward and set.
- (3) Working height is the smallest when the crank rod is moved downward and set.
- (4) After adjusting, fully tighten the special bolt.

● Working height of the presser foot can be adjusted in the range from 2mm to 6mm.

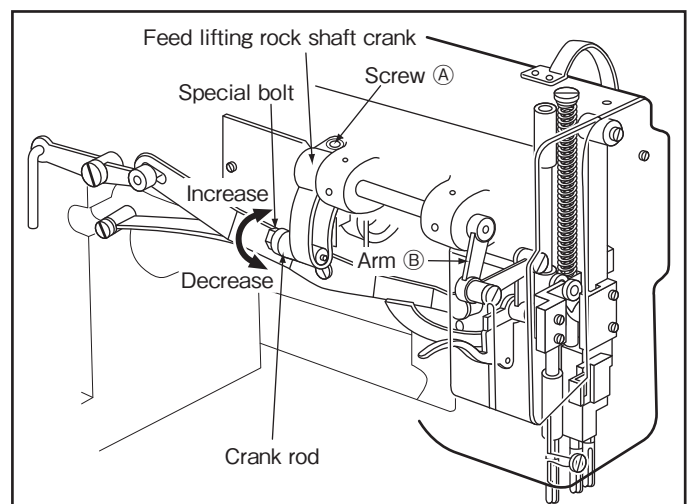

# HOW TO USE

## 2. Alternating up and down movement.

A good feed condition is attained when the alternating up and down movement is changed between the outside presser foot and the inside presser foot depending on the kind of fabric.

For example)

Reducing the up and down movement of the outside presser foot and increasing it of the inside presser foot may be effective for stitching the slippery fabric.

### (How to adjust)

- (1) Turn the pulley and stop it at the position where the thread take-up lever comes to the lowest.
  - (2) Down the presser foot.
  - (3) Loosen the feed lifting rock shaft crank set screw ㉑.
  - (4) Moving the arm ㉒ to the left, the up and down movement of the inside presser foot increases and it of the outside presser foot decreases.
  - (5) In contrast, moving the arm ㉒ to the right, the up and down movement of the inside presser foot decreases and it of the outside presser foot increases.
  - (6) After adjusting, fully tighten the screw ㉑.
- The up and down movement of the inside presser foot and it of the outside presser foot are factory-adjusted to 3mm and 4.2mm.

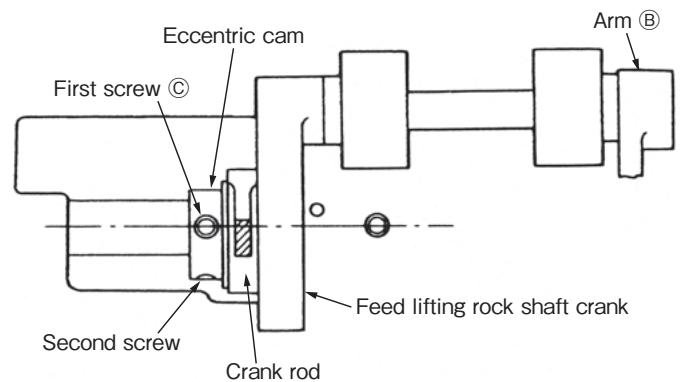
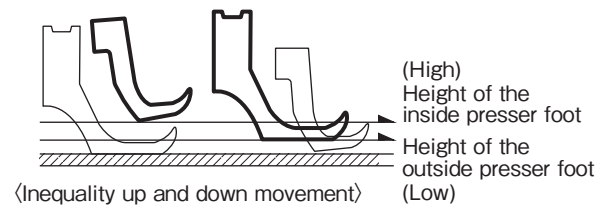
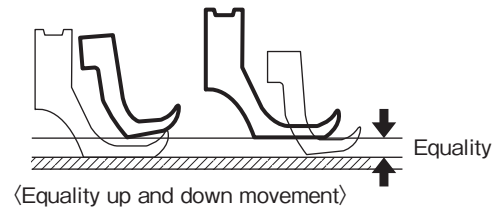

## 3. How to install the eccentric cam

- (1) Turn the pulley and stop it at the position where the thread take-up lever comes to the lowest.
- (2) In this condition, tighten the first screw ㉑ of the eccentric cam so that it is faced abeam as shown in the figure.

## 4. Fine adjustment of the eccentric cam

Remove the rubber plug is located in the front of the arm.

The eccentric cam can be finely adjusted through this hole.

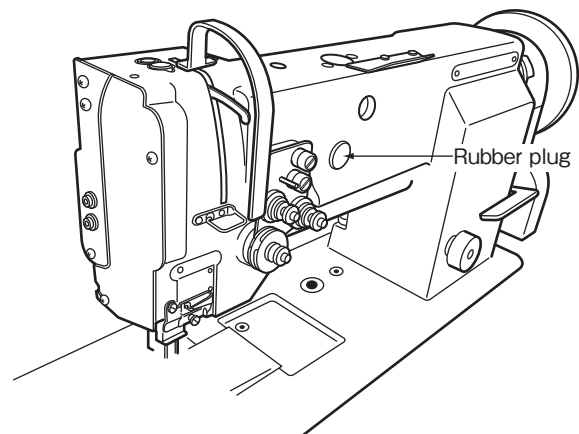



# SPECIFICATIONS

## LU2-4400-B0B • LU2-4420-B0B Specifications

Specifications		Model	LU2-4400-B0B	LU2-4420-B0B
		Number of needles		Single-Needle
Application		Heavy material		
Max. sewing speed (rpm)		2000		
Stitch length (mm)		0 to 9		
Presser foot stroke (mm)	Hand	8		
	Knee	16		
Needle		DP × 17 #23		
Needle bar stroke (mm)		36.0		
Thread take-up lever stroke (mm)		74.5		
Vertical stroke of upper feed (mm)		2.0 to 6.0		
Hook (horizontal rotating hook)		Large		
Lubrication system		Automatic lubrication		
Bed dimensions (mm)		517 × 178		
Needle gauge (mm)		Standard 6.4 Special 3.2, 4, 4.8, 8, 9.5, 12.7, 16, 19, 25.4		

Note: ● The bobbin should be of high quality free from deformation.

● Some materials, gauge sizes, and/or sewing conditions may require specifications other than those listed above.

● These specifications are subject to change for machine improvement





**JUKI CORPORATION**

Printed in Japan