

PARTS LIST

LK-1903B/BR35 PARTS LIST

下記 URL (PARTS Website/PC サイト) より、便利な検索機能のついた Web Parts Book をご利用頂けます。
ご利用には会員登録が必要です。(無料)

<https://juki.aftama.com/JUKI/JA>

You can use a Web Parts Book with a convenient search function from the URLs (PARTS Website/PC-site)
below. To use the PARTS Website, free membership registration is required.

<https://juki.aftama.com/JUKI/EN>

HOW TO MAKE USE OF THIS PARTS LIST

1.Explanation of codes

1)"*" mark.....means this part is changed from the previous parts book.

As to the details of the change, refer to "List for information of change".

2)"#01".....refer to "Note" explanation at bottom of page.

2.Codes on the "Qty" column

• Each numeral indicates the number of parts required.

• "0.1" and "2.5" indicate the length (in meters) of the respective parts.

3.Parentheses mean that the corresponding part is a subpart that constructs an assembly part.

4.Dotted lines on the Figures indicate assembly parts.

5.As to the parts with marks of "☆"(consumable parts) and "◎"(optional parts)on the respective parts, it is recommended to prepare spares.

パーツリストご利用に際して

1."注記"欄の記号説明

1)"*"印..... 前回のパーツブックに比較して今回変更された部品を意味します。

変更内容は"変更情報リスト"を参照してください。

2)"#01"..... ページ下の"注記"の説明を参照してください。

2.数量欄の数字は、個数を表し、0.1、2.5等の数値は、長さ(単位メートル)を表します。

3.数量欄の()は、組部品を構成している子部品であることを意味します。

4.イラストページの-----枠は、組構成であることを意味します。

5.リストページの"☆"(消耗部品)、"◎"(オプション部品)の印がついた部品は、予備を準備しておくことをお奨めします。

CONTENTS

目次

1. THREAD TENSION COMPONENTS.....	1
糸調子関係	
2. WIPER MECHANISM COMPONENTS.....	2
ワイパー関係	
3. EXCLUSIVE PARTS FOR LK-1903BS-311,LK-1903BS-312 (1).....	3
LK-1903BS-311, LK-1903BS-312専用部品(1)	
4. EXCLUSIVE PARTS FOR LK-1903BS-311,LK-1903BS-312 (2).....	5
LK-1903BS-311, LK-1903BS-312専用部品(2)	
5. BUTTON CLAMP COMPONENTS.....	7
ボタンつまみ関係	
6. FINE POSITION OF BUTTONS COMPONENTS (1).....	9
ボタンすりもみ関係(1)	
7. FINE POSITION OF BUTTONS COMPONENTS (2).....	11
ボタンすりもみ関係(2)	
8. DRIVE CAM COMPONENTS.....	13
カム関係	
9. INDEX COMPONENTS (1).....	15
インデックス関係(1)	
10. INDEX COMPONENTS (2).....	17
インデックス関係(2)	
11. FEEDER BALL COMPONENTS.....	19
フィダーボール関係	
12. TABLE & COVER COMPONENTS.....	21
脚卓・カバー関係	
13. BR CONTROL BOX COMPONENTS (FOR USE IN JAPAN AND GENERAL EXPORT).....	23
BR電装関係(日本, 一般輸出入)	
14. BR CONTROL BOX COMPONENTS (FOR EUROPE).....	25
BR電装関係(ヨーロッパ用)	
15. BR POWER SUPPLY COMPONENTS.....	27
BR入出力関係	
16. CONTROL BOX COMPONENTS.....	29
電装ボックス関係	
17. OPERATION PANEL COMPONENTS.....	31
操作パネル関係	
18. WIRING DIAGRAM.....	33
電装配線図	
19. BR35 WIRING DIAGRAM.....	35
BR35電装配線図	
20. ACCESSORIE PARTS COMPONENTS.....	37
付属品関係	

21. LIST FOR INFORMATION OF CHANGE..... 38
 変更情報リスト
NUMERICAL INDEX OF PARTS..... 39
 索引

1. THREAD TENSION COMPONENTS

糸調子関係

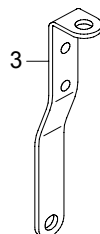
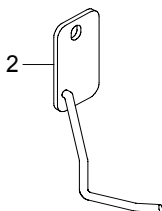
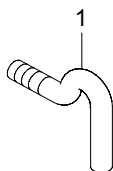

REF.NO	NOTE	PART NO	DESCRIPTION	品名	Qty
1		400-13452	L SHAPED THREAD GUIDE B	L 形糸案内 B	1
2		B5541-205-0A0	THREADING GUIDE ASM.	糸通しガイド組	1
3		B1114-581-000	THREAD GUIDE PLATE	糸案内板	1
	NOTE(注記)		ALL PARTS OTHER THAN ABOVE ARE SAME OF MODEL LK-1900B. 上記以外の部品は、LK-1900B と共通です。		

2. WIPER MECHANISM COMPONENTS

ワイパー関係

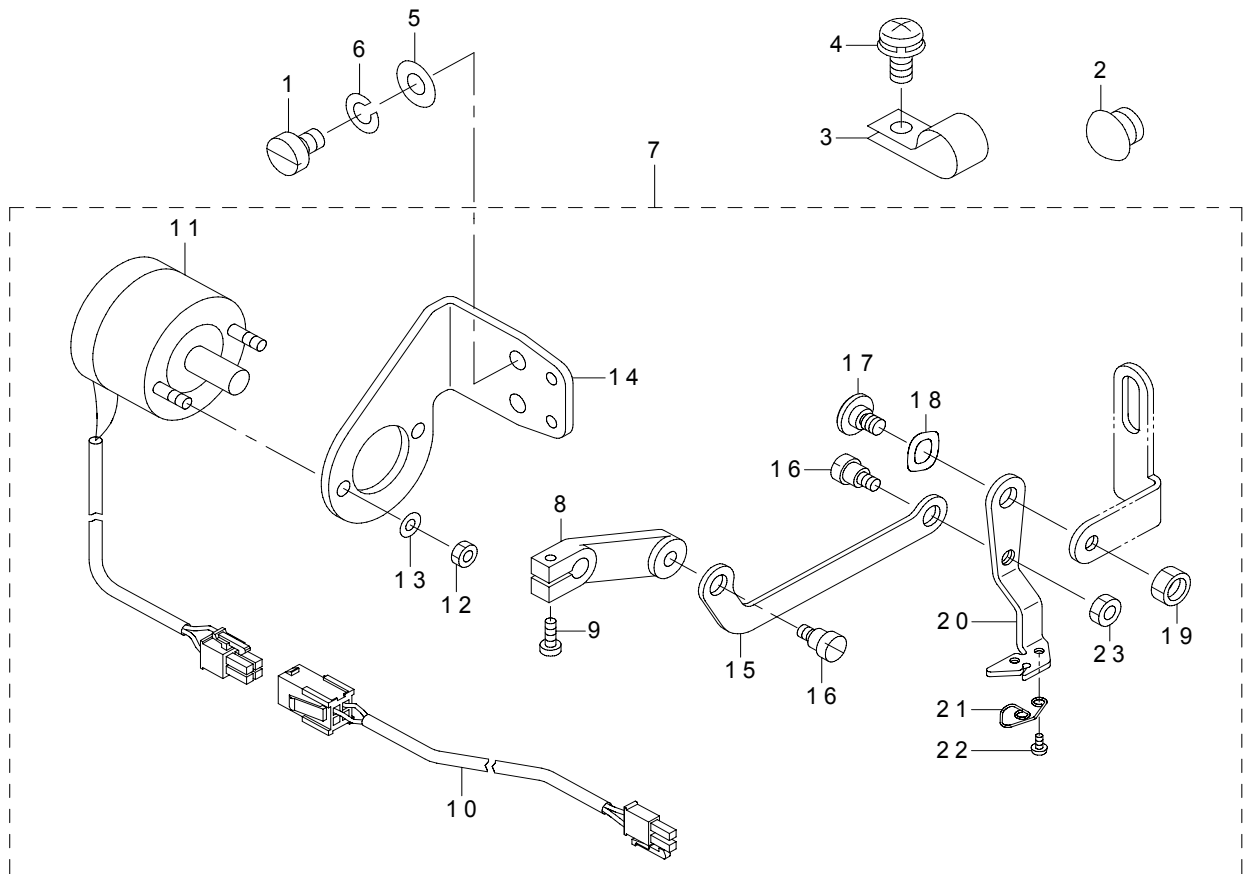

REF.NO	NOTE	PART NO	DESCRIPTION	品名	Qty
1		SM-6040650-TP	SCREW	平ねじ M4 L=6	2
2		TA-1250705-R0	RUBBER PLUG	止め栓	1
3		HX-0012300-0C	CABLE CLIP	ケーブルクリップ	4
4		SL-4041091-SC	SCREW M4 L=10	なべ小ねじセムス M4 X 0.7 L=10	4
5		WP-0450801-SD	WASHER 4.5X10X0.8	平座金 4.5 X 10 X 0.8	2
6		WS-0451040-KP	SPRING WASHER 4.5X8.5X1	ばね座金 4.5 X 8.5 X 1	2
7		400-18334	MAGNET WIPER ASM.	マグネットワイパー組	1
8		B2102-205-00A	WIPER ARM	ワイパー腕	(1)
9		SS-7111120-TP	SCREW	丸平ねじ	(1)
10		400-18335	SOLENOID RELAY CABLE ASM.	ソレノイド中継ケーブル組	(1)
11		141-47755	SOLENOID FOR WIPER ASM.	ワイパーソレノイド組	(1)
12		NM-6040003-SC	NUT M4	六角ナット M4	(2)
13		WS-0410002-KS	SPRING WASHER M4	ばね座金 M4	(2)
14		138-64509	SOLENOID FITTING PLATE	ワイパーソレノイド取付板	(1)
15		141-47607	WIPER LINK	ワイパーリンク	(1)
16		SD-0600181-TP	HINGE SCREW	段ねじ	(2)
17		SD-0640261-SP	HINGE SCREW D=6.35 H=2.6	段ねじ D=6.35 H=2.6	(1)
18		WZ-0640200-KP	WAVE WASHER	波形座金	(1)
19		NS-6120310-SP	NUT 3/16-28	六角ナット 3/16-28	(1)
20		400-09859	WIPER	ワイパー	(1)
21		141-47805	SPRING	ワイパー糸受けばね	(1)
22		SS-7060310-SP	SCREW 3/32-56 L=3	丸平ねじ 3/32-56 L=3	(2)
23		NS-6110310-SP	NUT 11/64-40	六角ナット 11/64-40	(1)

NOTE(注記)

ALL PARTS OTHER THAN ABOVE ARE SAME OF MODEL LK-1900B.
上記以外の部品は、LK-1900Bと共通です。

3. EXCLUSIVE PARTS FOR LK-1903BS-311,LK-1903BS-312 (1)

LK-1903BS-311, LK-1903BS-312専用部品 (1)

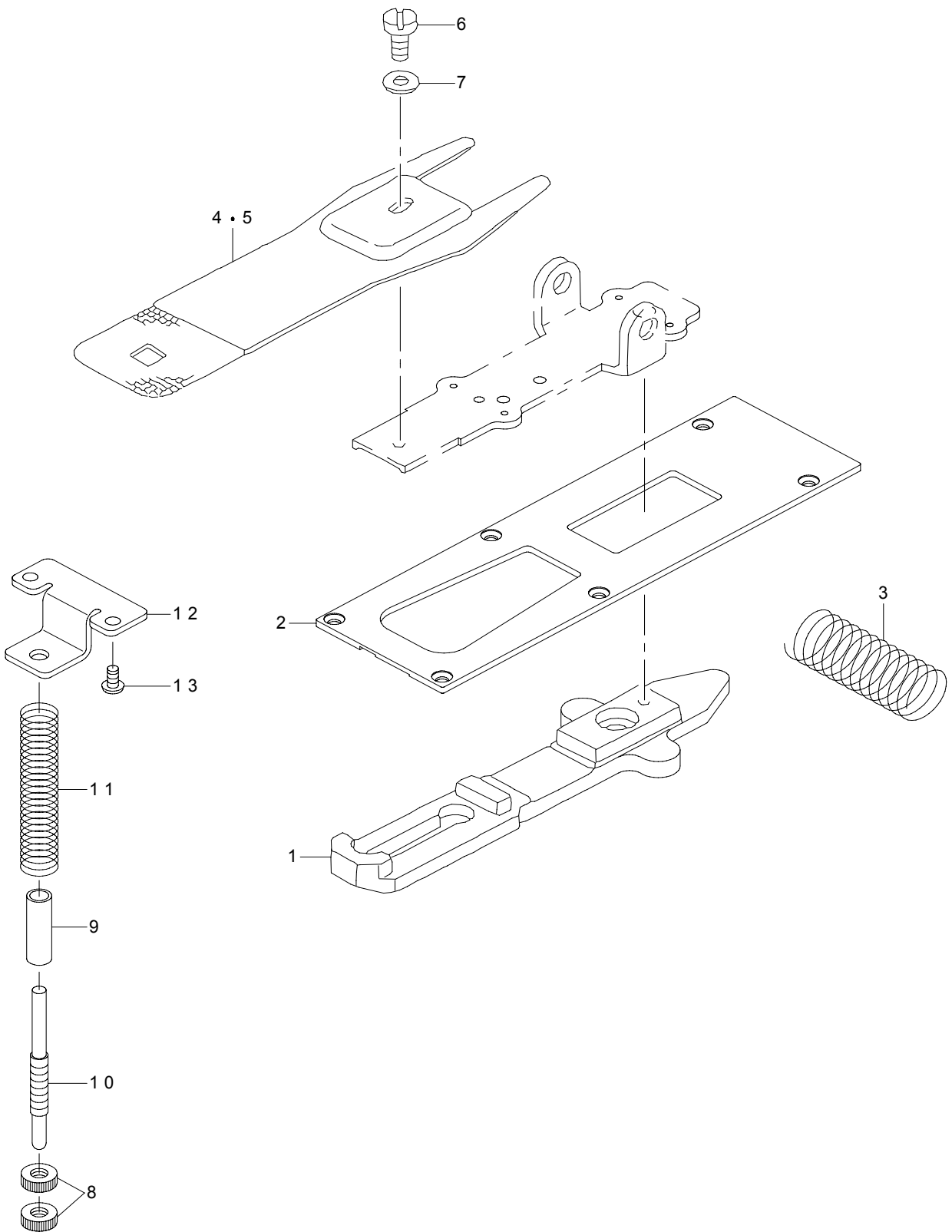

REF.NO	NOTE	PART NO	DESCRIPTION	品名	Qty
1		141-45106	CLOTH FEED PLATE	布送り板	1
2		400-06935	CLOTH FEED PRESSER PLATE B	布送り押え板 B	1
3		141-48407	VERTICAL FEED SHAFT SPRING	縦送り軸ばね	1
4	#01	MAZ-15502000	PRESSURE PLATE	布押え下板	1
5	#02	MAZ-15602000	PRESSURE PLATE	布押え下板	1
6		SS-9110543-CP	SCREW 11/64-40 L=5.3	六角ボルト 11/64-40 L=5.3	1
7		WP-0501016-SD	WASHER 5X10.5X1	平座金 5 X 10.5 X 1	1
8		229-28808	NUT	糸調子ナット	2
9		D2527-232-D00	SLEEVE	押えばね支えパイプ	1
10		141-46906	ADJUSTING SHAFT	押えばね調節軸	1
11		138-12003	PRESSURE SPRING	押えばね	1
12		138-11906	ACCEPT PLATE UPPER	押えばね受板上	1
13		SM-5040855-SN	SCREW	バインドねじ	2
		NOTE(注記)	#01....FOR LK-1903BS-311	LK-1903BS-311用	
			#02....FOR LK-1903BS-312	LK-1903BS-312用	

ALL PARTS OTHER THAN ABOVE ARE SAME OF MODEL LK-1900B.
上記以外の部品は、LK-1900B と共通です。

4. EXCLUSIVE PARTS FOR LK-1903BS-311,LK-1903BS-312 (2)

LK-1903BS-311, LK-1903BS-312専用部品 (2)

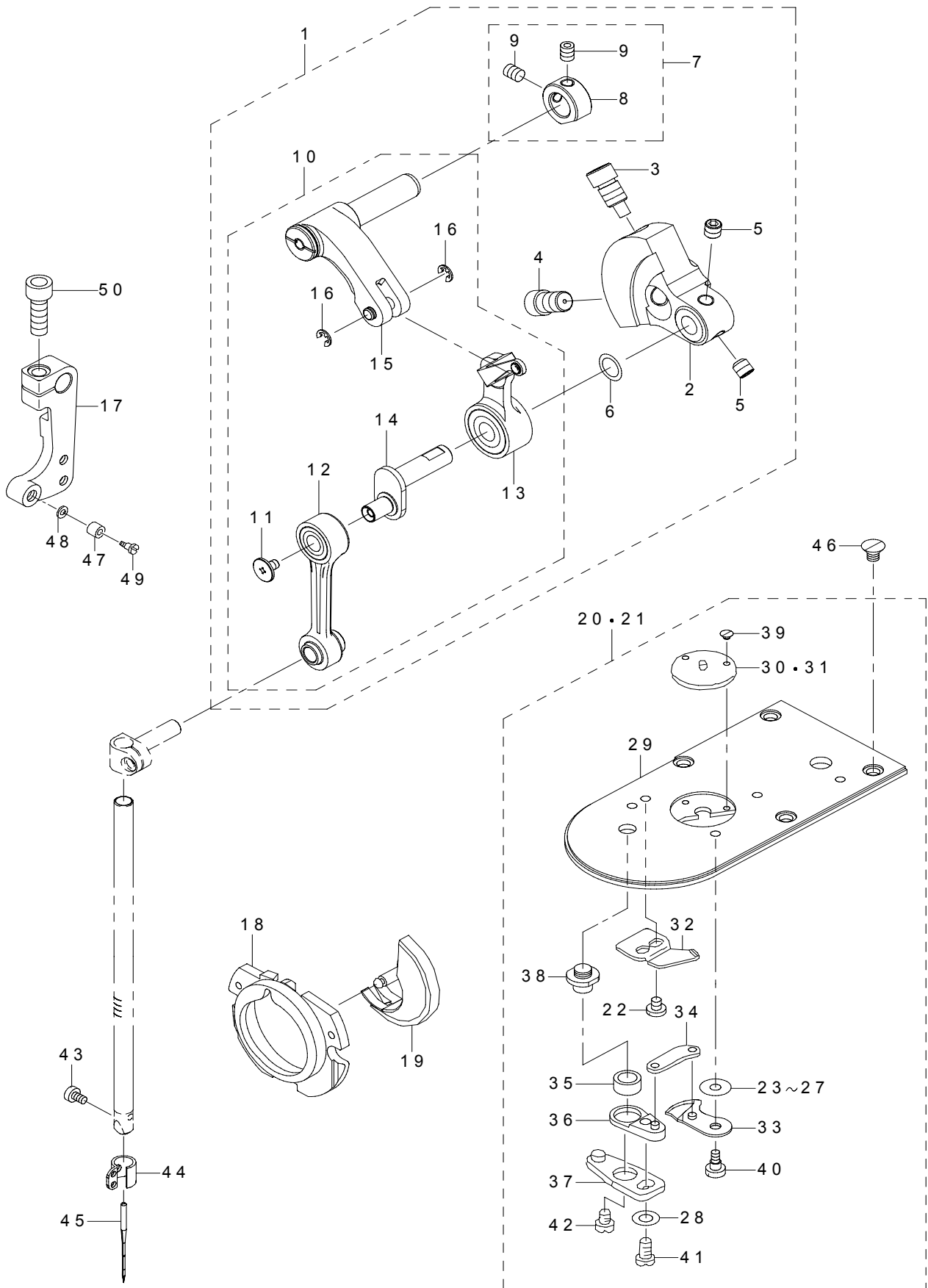

REF.NO	NOTE	PART NO	DESCRIPTION	品名	Qty
1		401-42785	COUNTER_WEIGHT_COMPL._3	釣合鍾結合 3	1
2		401-42691	COUNTER_WEIGHT	釣合鍾	(1)
3		400-10424	COUNTER_WEIGHT_SCREW_A	釣合鍾止めねじ A	(1)
4		400-10425	COUNTER_WEIGHT_SCREW_B	釣合鍾止めねじ B	(1)
5		400-10426	COUNTER_WEIGHT_SCREW_C	釣合鍾止めねじ C	(1)
6		WP-0820516-SP	WASHER 11.6X8.2X0.6	平座金 11.6 X 8.2 X 0.6	(1)
7		401-10841	THRUST_COLLAR_ASM.	スラスト受 (組)	(1)
8		401-10842	THRUST_COLLAR	スラスト受	(1)
9		SM-80506A2-TP	SCREW M5 L=6	六角穴付き止めねじ M5 L=6	(2)
10		401-42786	THREAD_TAKE_UP_COMPL._3	天秤結合 3	(1)
11		401-42701	LEFT_HAND_SCREW	左ねじ	(1)
12		401-42697	NEEDLE_BAR_CRANK_ROD_COMPL.	針棒クランクロッド (結合)	(1)
13		401-42787	THREAD_TAKE_UP_ASM._3	天秤組 3	(1)
14		401-42790	NEEDLE_BAR_CRANK_3	針棒クランク 3	(1)
15		401-42807	TAKE_UP_CRANK_ASM._3	天秤クランク組 3	(1)
16		RE-0300000-K0	E-RING 3	E 形止め輪 3	(2)
17		400-11949	CONNECTING_ARM_B	連動連結腕 B	1
18		141-03352	INNER_HOOK_PRESSER_ASM.B	中金押え B (結合)	1
19	☆	401-10846	SHUTTLE	中金	1
20	#01	401-42723	NEEDLE_PLATE_ASM.M	針板組 M	1
21	#02	401-42724	NEEDLE_PLATE_ASM.K	針板組 K	1
22		SS-7090410-SP	SCREW 9/64-40 L=3.5	丸平ねじ 9/64-40 L=3.5	(2)
23	#03	B2423-280-00A	MOVING_KNIFE_WASHER_A	動メス座金 A	(1)
24	#03	B2423-280-00B	MOVING_KNIFE_WASHER_B	動メス座金 B	(1)
25	#03	B2423-280-00C	MOVING_KNIFE_WASHER_C	動メス座金 C	(1)
26	#03	B2423-280-00D	MOVING_KNIFE_WASHER_D	動メス座金 D	(1)
27	#03	B2423-280-00E	MOVING_KNIFE_WASHER_E	動メス座金	(1)
28		WP-0450846-SP	WASHER	平座金	(1)
29		401-42725	NEEDLE_PLATE	針板	(1)
30	☆	#01 MAZ-15801000	GUIDE	針穴ガイド	(1)
31	☆	#02 MAZ-15601000	GUIDE	針穴ガイド	(1)
32	☆	B2424-280-000	FIXING_KNIFE	固定メス	(1)
33	☆	B2421-280-0A0	MOVING_KNIFE_ASM.	動メス (組)	(1)
34		B2418-280-000	MOVING_KNIFE_LINK	動メスリンク	(1)
35		B2416-280-000	THREAD_CUTTING_LEVER_RING	糸切りレバーリング	(1)
36		B2415-280-0A0	THREAD_CUTTER_LEVER_ASM.(SMALL)	糸切りレバー (小) (組)	(1)
37		B2414-280-0A0	THREAD_CUTTER_LEVER_ASM.(LARGE)	糸切りレバー (大) (組)	(1)
38		B2417-280-000	THREAD_CUTTER_LEVER_SHAFT	糸切りレバー軸	(1)
39		SS-1060210-TP	SCREW 3/32-56 L=2.2	皿ねじ 3/32-56 L=2.2	(2)
40		SD-0500091-TP	HINGE_SCREW D=5.0 H=0.9	段ねじ D=5 H=0.9	(1)
41		SS-7110740-TP	SCREW 11/64-40 L=7	丸平ねじ 11/64-40 L=7	(1)
42		SS-6110430-TP	SCREW 11/64-40 L=4.0	平ねじ 11/64-40 L=4	(1)
43	☆	SM-6030500-SN	SCREW M3 L=5	平ねじ M3 L=5	1
44	☆	400-06525	NEEDLE_BAR_THREAD_GUIDE	針棒糸案内	1
45	☆	MDP-170B1400	NEEDLE_DP_X17 #14	針 DPX 17 #14	1
46		SM-1040650-TP	SCREW	皿ねじ M4 L=6	4
47		B2619-372-000	STOP_MOTION_TRIPPING_LEVER_CAM	針数調節コロ	1
48		B1853-512-00E	HOOK_SHAFT_WASHER	釜軸座金	1
49		SD-0791276-TP	SHOULDER_SCREW	段ねじ D=7.94 H=12.7	1
50		SM-6061802-TP	SCREW M6 L=18	六角穴ボルト	1

NOTE(注記)

#01....FOR LK-1903BS-311
#02....FOR LK-1903BS-312
#03....SELECTIVE PARTS

LK-1903BS-311用
LK-1903BS-312用
選択部品

ALL PARTS OTHER THAN ABOVE ARE SAME OF MODEL LK-1900B.
上記以外の部品は、LK-1900B と共通です。

5. BUTTON CLAMP COMPONENTS

ボタンつまみ関係

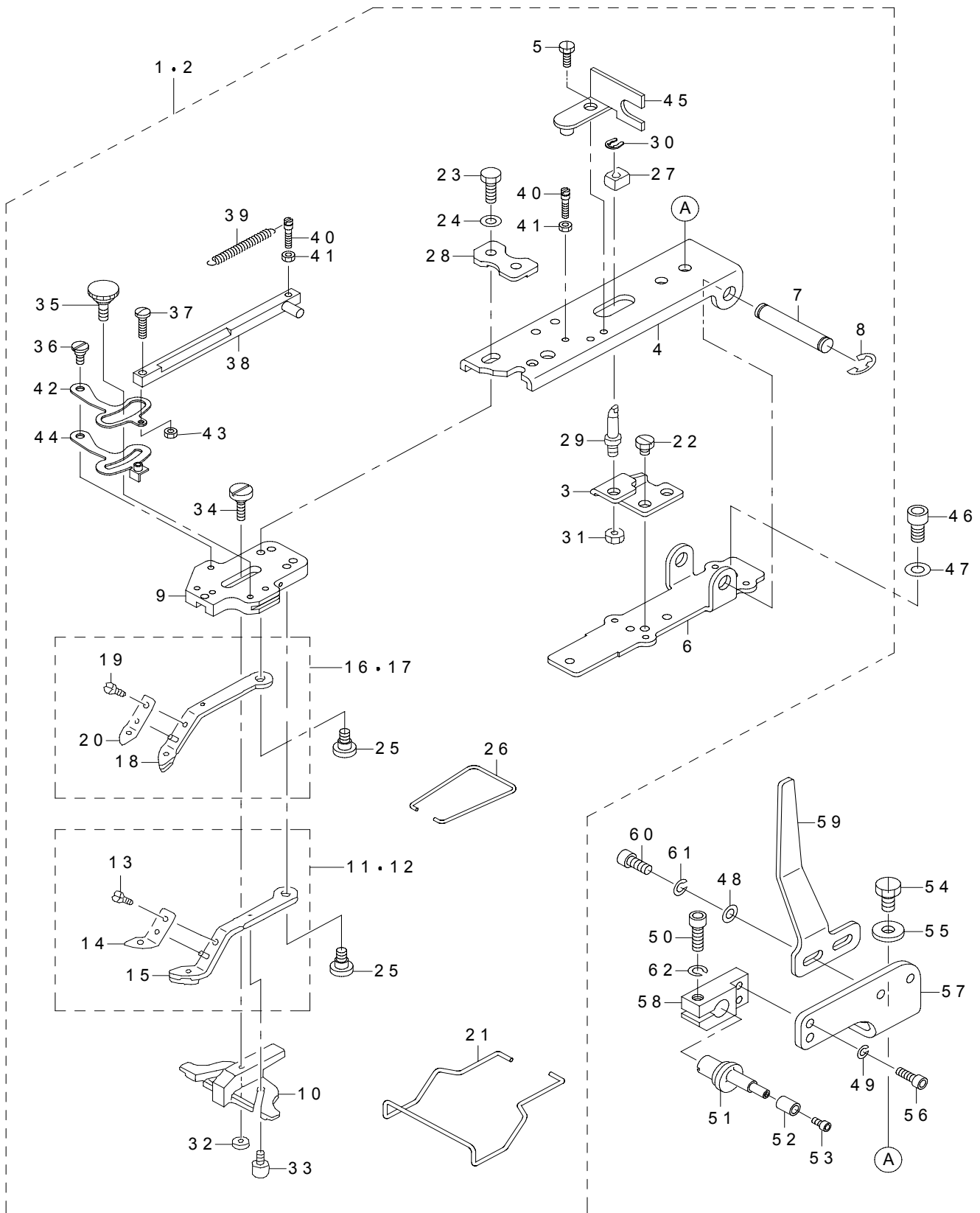

REF.NO	NOTE	PART NO	DESCRIPTION	品名	Qty
1	#01	141-90052	KNOB DEVICE JUNCTION COMPL.	小ボタン用つまみ装置結合	1
2	#02	141-90151	KNOB DEVICE JUNCTION COMPL.	中ボタン用つまみ装置結合	1
3		MAZ-15514000	SUPPORT PLATE	支柱取付板	(1)
4		141-46203	PICK-UP FOOT INSTALLING BASE	つまみ足取付台	(1)
5		SS-9091010-SP	SCREW 9/64-40 L=10	六角ボルト 9/64-40 L=10	(1)
6		141-46104	PICK-UP INSTALLING BASE	つまみ装置取付台	(1)
7		141-41402	INSTALLING SHAFT	つまみ装置取付軸	(1)
8		RE-0700000-K0	E-RING 7	E形止め輪7	(2)
9		141-46302	PICK-UP FOOT INSTALLING BASE	ボタンつまみ足取付台	(1)
10		MAZ-16522000	BUTTON GUIDE FOOT	ボタンガイド足	(1)
11	#01	141-90458	S BUTTON CLAMP JAW LEVER ASM. R	小ボタン用つまみ足右結合	(1)
12	#02	MAZ-166070B0	M BUTTON CLAMP JAW LEVER ASM. R	中ボタン用つまみ足右結合	(1)
13		SS-7090410-SP	SCREW 9/64-40 L=3.5	丸平ねじ 9/64-40 L=3.5	(2)
14		MAZ-08829000	SPRING RIGHT	ボタンつまみ板ばね(右)	(1)
15		MAZ-166070A0	M BUTTON CLAMP JAW LEVER ASM. R	中ボタン用つまみ足右組	(1)
16	#01	141-90557	S BUTTON CLAMP JAW LEVER ASM. L	小ボタン用つまみ足左結合	(1)
17	#02	MAZ-166080B0	KNOB FOOT JUNCTION (LEFT)	中ボタン用つまみ足左結合	(1)
18		MAZ-166080A0	MIDDLE BUTTON CLAMP LEVER L	中ボタン用つまみ足左結合	(1)
19		SS-7090410-SP	SCREW 9/64-40 L=3.5	丸平ねじ 9/64-40 L=3.5	(2)
20		MAZ-08828000	SPRING LEFT	ボタンつまみ板ばね(左)	(1)
21		D3130-M1Y-C00	FINGER GUARD	指ガード	(1)
22		SS-9110460-CP	SCREW 11/64-40 L=4	六角ボルト 11/64-40 L=4	(2)
23		SS-9621413-SP	SCREW 3/16-32 L=13.5	六角ボルト 3/16-32 L=13.5	(2)
24		WP-0501016-SD	WASHER 5X10.5X1	平座金 5 X 10.5 X 1	(2)
25		SD-0640391-TP	HINGE SCREW D=6.35 H=3.9	段ねじ D=6.35 H=3.9	(2)
26		B2561-372-000	BUTTON CLAMP SPRING	ボタンつまみ足ばね	(1)
27		MAZ-15515000	SLIDE BLOCK	横振れ防止角駒	(1)
28		141-90300	FITTING BASE PRESSER PLATE	つまみ足取付台押え板	(1)
29		135-40901	STATIONING BLOCK SHAFT	横振れ防止支柱	(1)
30		D2548-232-D00	SNAP RING FOR CONNECTING ROD	横振れ防止柱止め輪	(1)
31		NS-6150310-SP	NUT 15/64-28	六角ナット 15/64-28	(1)
32		B2553-372-000	NUT	ボタンガイド足止めねじ B	(1)
33		B2560-372-000	BUTTON CLAMP STOP PIN	つまみ足開きピン	(2)
34		SD-0550303-TP	HINGE SCREW D=5.5 H=3	段ねじ D=5.5 H=3	(1)
35		B2549-372-R00	CLAMP SCREW A	開きレバー止めねじ A	(1)
36	*	SD-0500404-SP	HINGE SCREW	段ねじ	(1)
37		SS-7091480-SP	SCREW 9/64-40 L=13.5	丸平ねじ 9/64-40 L=13.5	(1)
38		MAZ-088270A0	CLAMP PELEASE LINK ASM.	クランプ解除リンク(組)	(1)
39		GBR-01606000	RELEASE RETURN SPRING	解除戻しばね	(1)
40		GBR-01607000	SPRING HOOK	スプリングフック	(2)
41		NS-6080210-SP	NUT 1/8-44	六角ナット 1/8-44	(2)
42		GBR-01601000-A	CLAMP RELEASE LEVER	クランプ解除レバー	(1)
43		NS-6090310-SP	NUT 9/64-40	六角ナット 9/64-40	(1)
44		B2548-372-RA0	BUTTON CLAMP STOP LEVER ASM.	つまみ足開きレバー組	(1)
45		D2572-M1Y-C0F	LINK SUPPORTING PLATE	リンク支え板	(1)
46		SM-6061202-TP	SCREW M6 L=12	六角穴ボルト M6 L=12	1
47		WP-0612516-SD	WASHER 6.1X15.2X2.5	平座金 6.1 X 15.2 X 2.5	1
48		WP-0531000-SD	WASHER M5	平座金小形丸 M5	2
49		WS-0410002-KN	SPRING WASHER	ばね座金 M4	2
50		SM-6051602-TP	SCREW M5X0.8 L=16	六角穴ボルト M5 X 0.8 L=16	1
51		182-27603	HOOK	布押え上げフック	1
52		182-00709	BUTTON GAUGE FOR FOUR HOLES	ローラー	1
53		SM-6030602-TP	SCREW M3X0.5 L=6	六角穴ボルト M3 X 0.5 L=6	1
54		SS-9151120-CP	SCREW 15/64-28 L=11	六角ボルト 15/64-28 L=11	2
55		WP-0612516-SD	WASHER 6.1X15.2X2.5	平座金 6.1 X 15.2 X 2.5	2
56		SM-6041202-TP	SCREW M4X0.7 L=12	六角穴ボルト	2
57		GBR-25004000	HOLDER BRACKET	ホルダブラケット	1
58		182-09007	HOOK HOLDER	フックホルダ	1
59		GBR-25003000	LIFTING ACTUATING PLATE	押え上げ作動板	1
60		SM-6051202-TP	SCREW M5X0.8 L=12	六角穴ボルト M5 X 0.8 L=12	2
61		WS-0510002-KP	SPRING WASHER 5.1X9.2X1.3	歯付き座金 5.1 X 9.2 X 1.3	2
62		WS-0510002-KP	SPRING WASHER 5.1X9.2X1.3	歯付き座金 5.1 X 9.2 X 1.3	1
		NOTE(注記)	#01....FOR LK-1903B-311 #02....FOR LK-1903B-312	LK-1903B-311用 LK-1903B-312用	

6. FINE POSITION OF BUTTONS COMPONENTS (1)

ボタンすりもみ関係 (1)

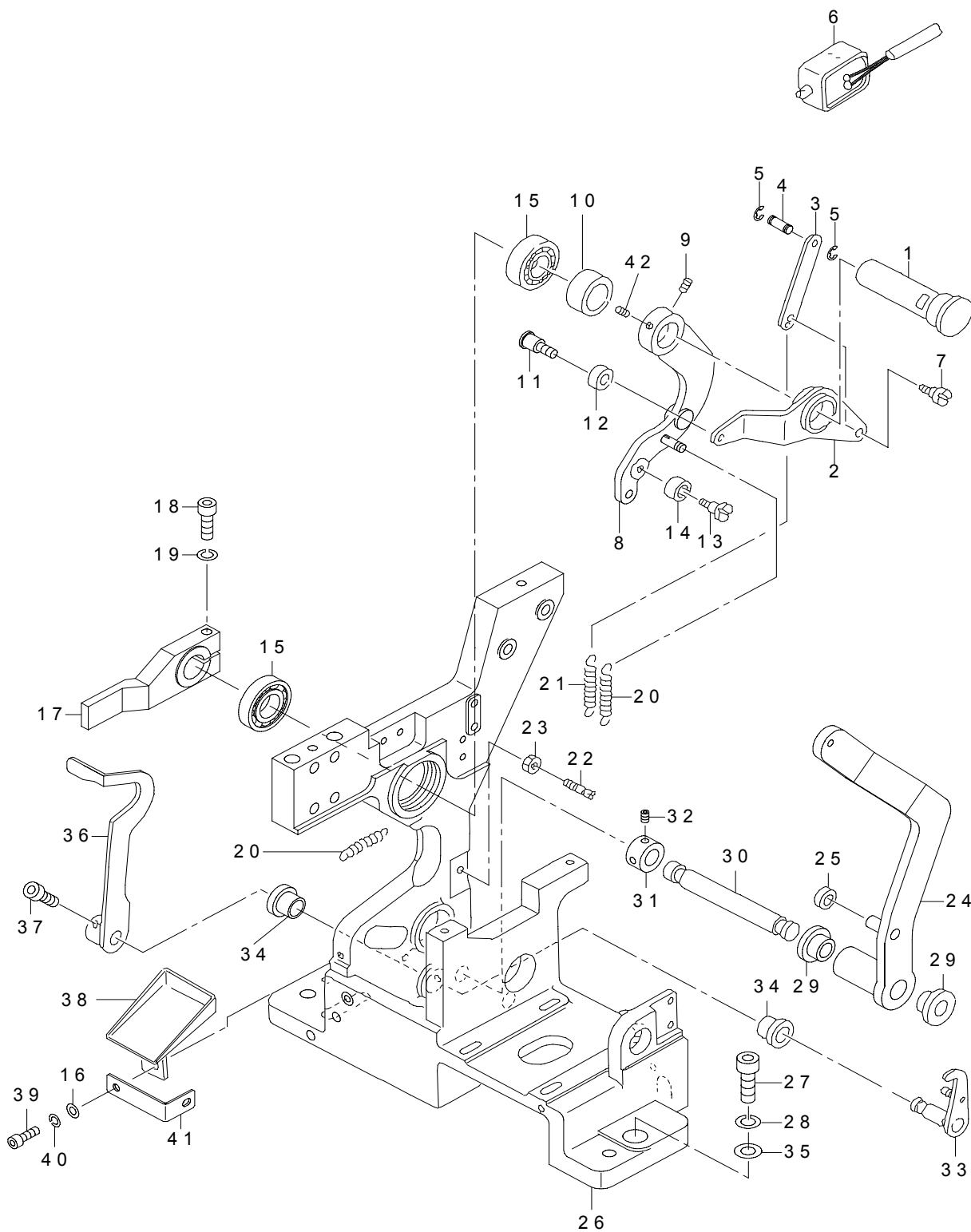

REF.NO	NOTE	PART NO	DESCRIPTION	品名	Qty
1		165-52507	ARM SHAFT	アーム軸	1
2		182-19709	RUBBING UP-AND-DOWN LEVER	すりもみ昇降レバー	1
3		182-18206	RUBBING UP-AND-DOWN LINK	すりもみ昇降リンク	1
4		165-57209	PIN	止め輪用ピン E リングつけ	1
5		RE-0200000-K0	E-RING	E 形止め輪2	2
6		GBR-10852000	MAGNET	すりもみ下降マグネット	1
7		SD-0600341-TP	HINGE SCREW D=6.0 H=3.4	段ねじ	1
8		182-27850	UP AND DOWN LEVER ASM.	上下レバー組	1
9		SM-8050602-TP	SCREW M5 L=6	止めねじ M 5 X 0. 8 L =6	2
10		165-52606	THRUST COLLAR	アーム軸カラー	1
11		SD-0600401-TP	HINGE SCREW D=6 H=4	段ねじ D =6 H =4	1
12		182-19808	RUBBING ROLLER	すりもみローラ	1
13		SD-0601021-SP	HINGE SCREW D=6 H=10.2	段ねじ D =6 H =10. 2	1
14		165-56706	BEARING	ニードルベアリング	1
15		SB-1150004-00	RADIAL BEARING	ラジアル軸受	2
16		WP-0430800-SC	WASHER M4	平座金小形丸 M 4	1
17		182-07902	UP AND DOWN ARM	布押え上下アーム	1
18		SM-6052502-TP	SCREW M5X0.8 L=25	六角穴ボルト	1
19		WS-0510002-KN	SPRING WASHER	ばね座金 5. 1 X 9. 2 X 1. 3	1
20		165-54008	SPRING	引張りばね	2
21		165-53208	SPRING	すりもみ上昇ばね	1
22		165-53307	HOOK	すりもみフック	1
23		NM-6050001-SC	NUT M5	六角ナット M 5 X 0. 8 1種	1
24		182-06706	TURNING LEVER	回転レバー A	1
25		165-56805	COLLAR	内輪	1
26		182-27702	MAIN BODY	本体フレーム	1
27		SM-6063002-TP	SCREW M6 L=30	搬送体軸受止めねじ	3
28		WS-0610002-KN	SPRING WASHER 6.1X12.2X1.5	ばね座金 M 6	3
29		165-57506	LEVER SHAFT METAL	回転レバー軸メタル	2
30		165-54503	SHAFT	シャフト	1
31		165-59304	COLLAR	回転アームカラー	1
32		SM-8040602-TP	SCREW M4X0.7 L=6	止めねじ	2
33		182-17752	CLAMP RELEASE ASM.	クランプ解除組	1
34		165-57605	SHAFT BUSHING	クランプ解除軸メタル	2
35		165-59601	WASHER	座金	3
36		182-06904	CLAMP RELEASE ARM	クランプ解除アーム	1
37		SM-6050802-TP	SCREW M5X0.8 L=8	六角穴ボルト M 5 X 0. 8 L =8	2
38		165-50105	SUPPORT PLATE	排出受皿	1
39		SM-6040802-TP	SCREW M4X0.7 L=8	六角穴ボルト	1
40		WS-0410002-KN	SPRING WASHER	ばね座金 M 4	1
41		GBR-25005000	CAM FIXING PLATE	布押え下げカム固定板	1
42		SM-8050612-TP	SCREW M5X6	止めねじ M 5 X 0. 8 L =6	1

7. FINE POSITION OF BUTTON COMPONENTS (2)

ボタンすりもみ関係 (2)

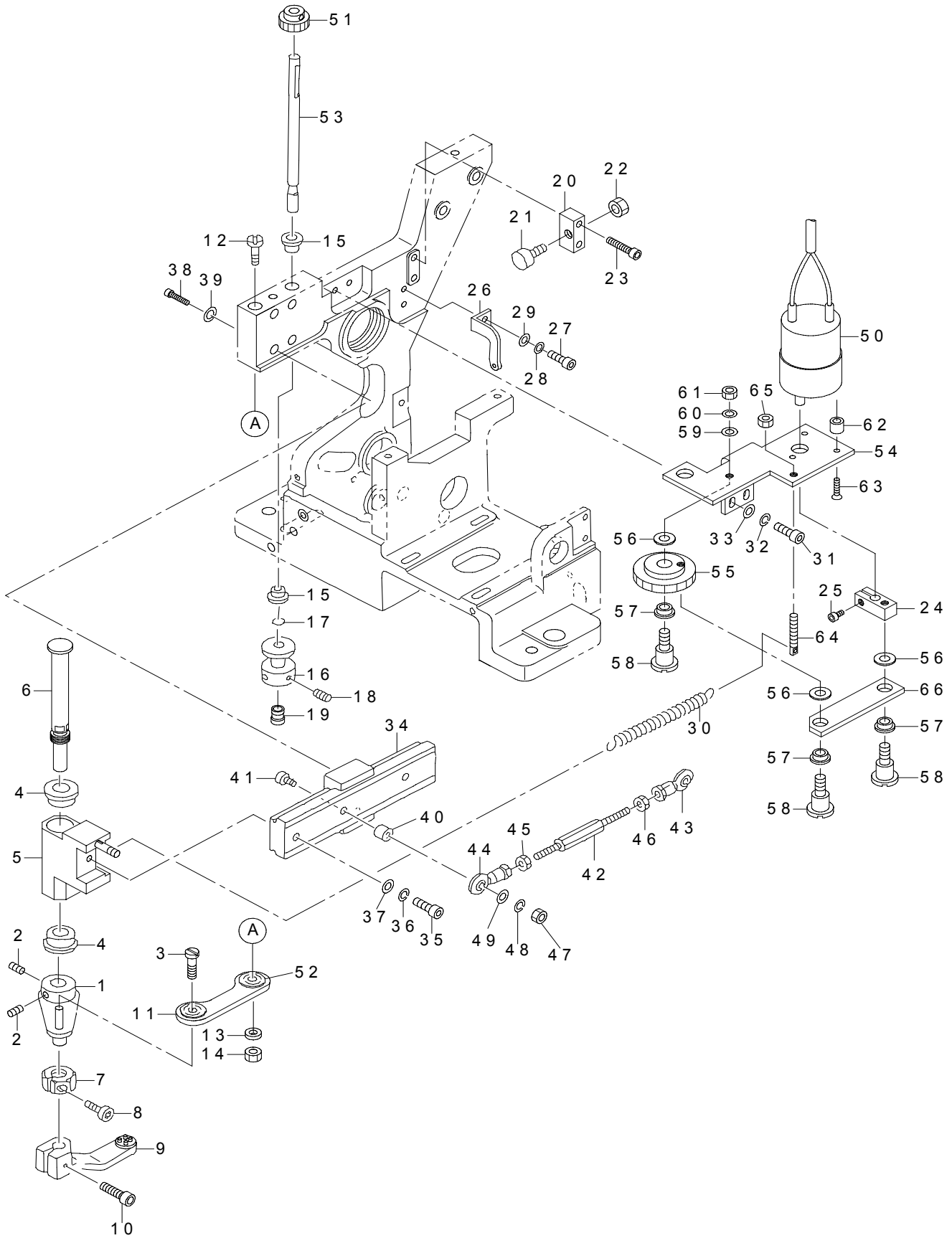

REF.NO	NOTE	PART NO	DESCRIPTION	品名	Qty
1		182-06003	TURNING LEVER BOSS	旋回レバー	1
2		SM-8050602-TP	SCREW M5 L=6	止めねじ M5 X 0.8 L=6	2
3		165-50808	SCREW	球面軸取付ねじ	1
4		165-57407	ARM SHAFT METAL	旋回アーム軸メタル	2
5		182-27959	TURNING HEAD ASM.	旋回ヘッド組	1
6		182-05906	TURNING SHAFT	旋回軸	1
7		182-06409	STOPPER	調整ストッパ	1
8		SM-6031202-TP	SCREW M3X0.5 L=12	六角穴ボルト	1
9		165-57902	BUTTON CARRIER A	ボタンキャリア A	1
10		SM-6051402-TP	SCREW M5X0.8 L=14	六角穴ボルト	1
11		182-06607	CONNECTING PLATE	連結板	1
12		182-05708	SCREW	球面軸受ボルト	1
13		WS-0510002-KS	SPRING WASHER M5	ばね座金 M5	1
14		NM-6050001-SC	NUT M5	六角ナット M5 X 0.8 1種	1
15		165-57308	METAL	含油メタル	2
16		165-51905	HOOK	上下フック	1
17		165-58801	O-RING	回転ロッド Oリング	1
18		SM-8040602-TP	SCREW M4X0.7 L=6	止めねじ	2
19	☆	182-00501	WORK ATTACHMENT (SMALL)	ワークアタッチメント (小)	1
20		182-18800	STOPPER HOLDER	ストッパホルダ	1
21		165-52309	STOPPER	LMガイドストッパー	1
22		NM-6040001-SC	NUT M4	六角ナット M4	1
23		SM-6042002-TP	SCREW M4X0.7 L=20	六角穴ボルト	2
24		GBR-11112000	DRIVING ARM	ロッド駆動腕	1
25		SS-6111052-TP	SCREW	六角穴ボルト	1
26		182-05401	SPRING HOOK	スタートカム戻しばねフック	1
27		SM-6041202-TP	SCREW M4X0.7 L=12	六角穴ボルト	2
28		WS-0410002-KN	SPRING WASHER	ばね座金 M4	2
29		WP-0430800-SC	WASHER M4	平座金小形丸 M4	2
30		165-51806	SPRING	旋回アーム戻しばね	1
31		SM-6041002-TP	SCREW M4 L=10	六角穴ボルト M4 X 0.7 L=10	2
32		WS-0410002-KN	SPRING WASHER	ばね座金 M4	2
33		WP-0430800-SC	WASHER M4	平座金小形丸 M4	2
34		165-56607	LM GUIDE	LMガイド	1
35		SM-6041402-TP	SCREW M4 L=14	六角穴ボルト M4	1
36		WS-0410002-KN	SPRING WASHER	ばね座金 M4	1
37		WP-0430800-SC	WASHER M4	平座金小形丸 M4	1
38		SM-6031402-TP	SCREW	六角穴ボルト	4
39		WS-0310002-KN	SPRING WASHER M3	ばね座金 3.1 X 5.9 X 0.7	4
40		165-50402	COLLAR B	ロッドエンドカラー B	1
41		SM-6042502-TP	SCREW M4X0.7 L=25	六角穴ボルト M4 X 0.7 L=25	1
42		165-50204	CONNECTING ROD	連結ロッド	1
43		165-56409	ROD END	ロッドエンド軸受	1
44		165-56300	ROD END	ロッドエンド軸受	1
45		NM-6040001-SC	NUT M4	六角ナット M4	1
46		GBR-01175000	ROD END NUT LEFT	ロッドエンドナット左	1
47		NM-6040001-SC	NUT M4	六角ナット M4	1
48		WS-0410002-KN	SPRING WASHER	ばね座金 M4	1
49		WP-0430800-SC	WASHER M4	平座金小形丸 M4	1
50		GBR-108550A0	DC MOTOR ASM.	すりもみ DC モータ組	1
51		GBR-11110000	PINION A	すりもみロッド歯車 A	1
52		165-56508	SPRIT	球面軸受	1
53		182-06201	ROTATING ROD	回転ロッド	1
54		GBR-11109000	BRACKET	すりもみモータブラケット	1
55		GBR-11111000	PINION B	すりもみロッド歯車 B	1
56		GBR-11114000	WASHER	スラストワッシャ	3
57		E5006-171-000	PS BEARING	P. S 軸受	3
58		SD-0600651-TP	HINGE SCREW	段ねじ D=6 H=6.5	3
59		WP-0430801-SC	WASHER 4.3X9X0.8	平座金 4.3 X 9 X 0.8	1
60		WS-0410002-KN	SPRING WASHER	ばね座金 M4	1
61		NS-6110360-SP	NUT	六角ナット	1
62		GBR-11115000	MOTOR SPACER.	モータスペーサ	3
63		SM-1031401-SC	SCREW M3X0.5 L=14	皿小ねじ M3 X 0.5 L=14	3
64		262-26506	SPRING HOOK	補助カム戻しばね掛け	1
65		NS-6110360-SP	NUT	六角ナット	1
66		GBR-11113000	LINK	すりもみリンク	1

8. DRIVE CAM COMPONENTS

カム関係

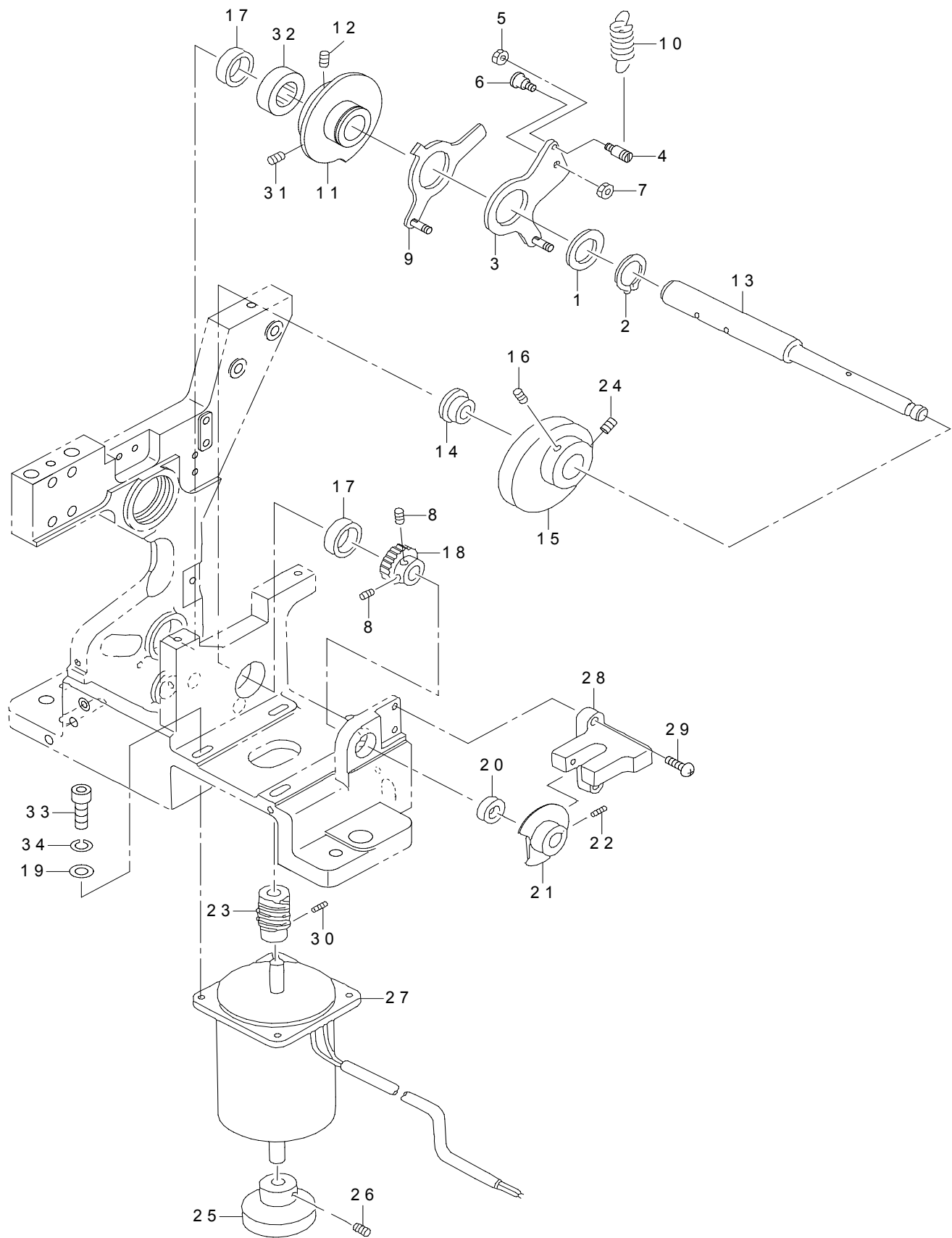

REF.NO	NOTE	PART NO	DESCRIPTION	品名	Qty
1		GBR-01120000	COLLAR	カラー	1
2		RC-2500001-KP	RETAINING RING 25	C形止め輪25	1
3		182-17950	START TIMING CAM ASM.	スタートタイミングカム組	1
4		165-62803	HOOK	スタートカム引上げフック	1
5		NM-6040001-SC	NUT M4	六角ナット M4	1
6		165-62902	HINGE SCREW	二段スイッチ段上ねじ	1
7		NM-6050001-SC	NUT M5	六角ナット M5 X 0.8 1種	1
8		SM-8050602-TP	SCREW M5 L=6	止めねじ M5 X 0.8 L=6	2
9		182-27553	HOLDING CLAMP DRIVE CAM ASM.	布押え下げカム組	1
10		B1426-771-000	SPRING	針振り部引張りばね A	1
11		182-07209	DOUBLE CAM	つまみ足ダブルカム	1
12		SM-8050612-TP	SCREW M5X6	止めねじ M5 X 0.8 L=6	1
13		182-07506	CAM SHAFT	カムシャフト	1
14		165-60104	CAM SHAFT COLLAR 1	カム軸カラー1	1
15		165-61607	SPINNER OSCILLATING ARM CAM	旋回アームカム	1
16		SM-8050812-TP	SCREW M5X8	止めねじ M5 X 0.8 L=8	1
17		GBR-01168000	NEEDLE BEARING 3	ニードルベアリング	2
18		165-62001	WORM WHEEL	ウォームホイール	1
19		WP-0641600-SC	WASHEW 6.4X12.5X1.6	平座金	4
20		165-62308	NEEDLE BEARING	ニードルベアリング	1
21		165-60302	SENSOR DOCK	カム軸センサードック	1
22		SM-8040602-TP	SCREW M4X0.7 L=6	止めねじ	1
23		165-62100	WORM GEAR	ウォームギア	1
24		SM-8050842-TP	SETSCREW	止めねじ	1
25		165-61904	MOTOR KNOB	アームモーターつまみ	1
26		SM-8050602-TP	SCREW M5 L=6	止めねじ M5 X 0.8 L=6	1
27		GBR-108590A0	DC MOTOR ASM.	旋回アーム DC モーター組	1
28		HD-0003600-00	PHOTO MICRO SENSOR	フォトマイクロセンサ	1
29		SL-4031081-SC	SCREW M3 L=10	なべねじセムス M3 L=10	2
30		SM-8040402-TP	SCREW M4X0.7 L=4	止めねじ M4 X 0.7 L=4	2
31		SM-8050842-TP	SETSCREW	止めねじ	1
32		165-60203	CAM SHAFT COLLAR 2	カム軸カラー2	1
33		SM-6062002-TP	SCREW M6 L=20	六角穴ボルト M6 L=20	4
34		WS-0610002-KN	SPRING WASHER 6.1X12.2X1.5	ばね座金 M6	4

9. INDEX COMPONENTS (1)

インデックス関係 (1)

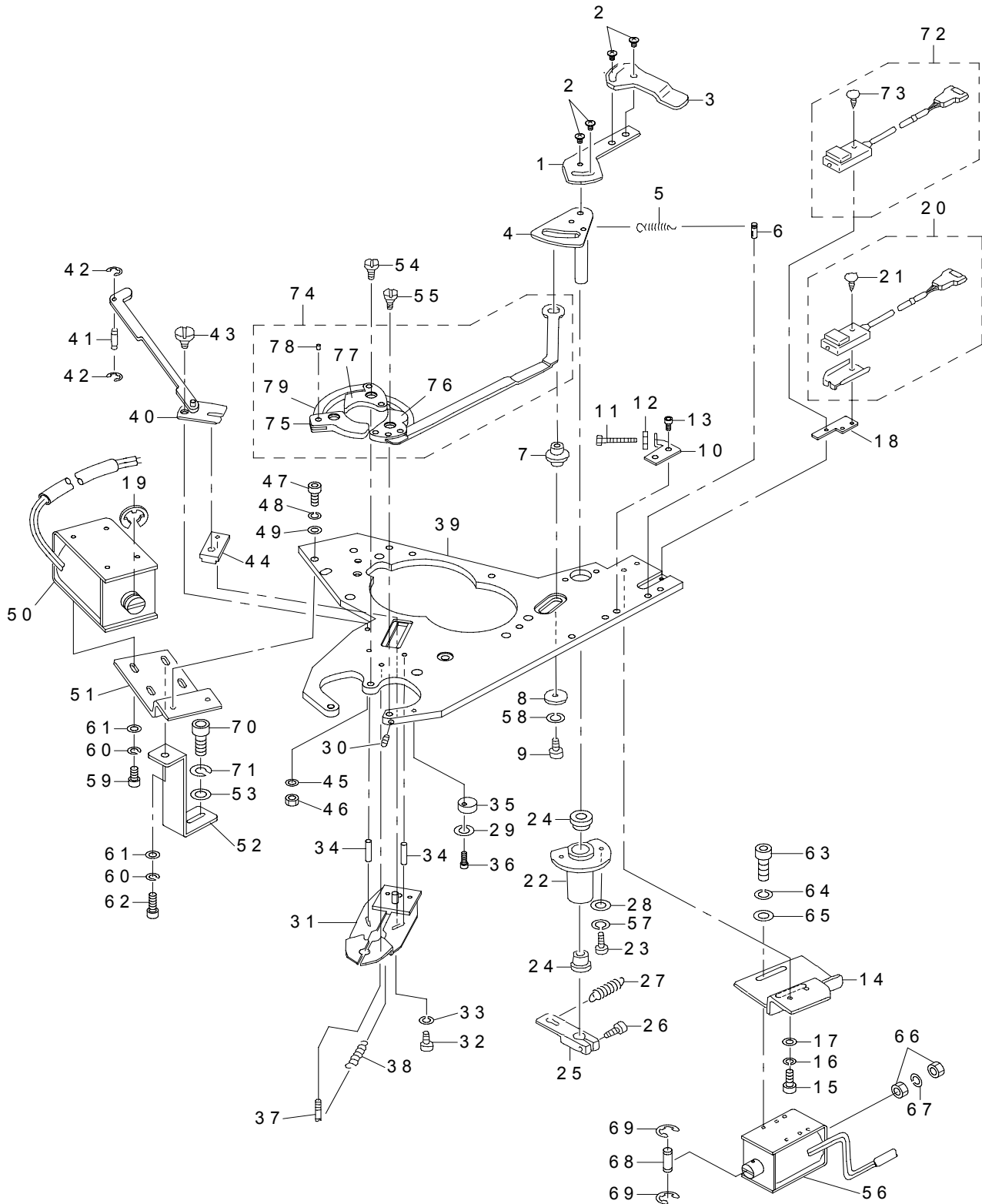

REF.NO	NOTE	PART NO	DESCRIPTION	品名	Qty
1		165-66507	CHECK DOG	三つ爪ドッグ	1
2		SM-0040601-SC	SCREW M4X0.7 L=6	トラス小ねじ M 4 X 0. 7 L = 6	4
3		165-74105	DOG	すりもみセンサドッグ	1
4		165-66002	SPINNER CAM	位置決めカム	1
5		165-53208	SPRING	すりもみ上昇ばね	1
6		182-18909	DW PIN 4X12	DWピン 4 X 1 2	1
7		165-65707	SHAFT (3)	軸 (3)	1
8		B2107-816-000-A	WASHER	二重環ロッド座金	1
9		SM-6041002-TP	SCREW M4 L=10	六角穴ボルト M 4 X 0. 7 L = 1 0	1
10		165-66606	STOPPER BKT	位置決めストッパー BKT	1
11		SM-8042502-TP	SCREW M4X0.7 L=25	止めねじ M 4 X 0. 7 L = 2 5	1
12		NM-6040001-SC	NUT M4	六角ナット M 4	1
13		SM-6040802-TR	SCREW M4X0.7 L=8	六角穴ボルト M 4 X 0. 7 L = 8	2
14		165-67000	BRACKET (1)	ブラケット (1)	1
15		SM-6041002-TP	SCREW M4 L=10	六角穴ボルト M 4 X 0. 7 L = 1 0	2
16		WS-0410002-KN	SPRING WASHER	ばね座金 M 4	2
17		WP-0430800-SC	WASHER M4	平座金小形丸 M 4	2
18		165-74006	BRACKET	すりもみセンサブラケット	1
19		RE-1200000-K0	E-RING 12	E 形止め輪 1 2	1
20		GBR-108430A0	RUB COMPLETION SWITCH ASM.	すりもみ完了スイッチ組	1
21		SM-0861201-SA	SCREW	トラスねじ M 2. 6 L = 1 2	(1)
22		165-65905	CUPLING	ハウス	1
23		SM-6041002-TP	SCREW M4 L=10	六角穴ボルト M 4 X 0. 7 L = 1 0	2
24		165-72406	METAL	含油メタル	2
25		165-66408	LINK LEVER	リンクレバー	1
26		SM-6041202-TP	SCREW M4X0.7 L=12	六角穴ボルト	1
27		182-01608	SPRING 2	ダブルカム戻しばね 2	1
28		WP-0430800-SC	WASHER M4	平座金小形丸 M 4	2
29		WP-0430800-SC	WASHER M4	平座金小形丸 M 4	1
30		SM-8030402-TP	SCREW M3X0.5 L=4	止めねじ	1
31		165-67166	SHUTTER PLATE ASM.	シャッター板組	1
32		SM-6041202-TP	SCREW M4X0.7 L=12	六角穴ボルト	1
33		WS-0410002-KN	SPRING WASHER	ばね座金 M 4	1
34		182-04107	PIN	平行ピン 3 X 1 2	2
35		182-09502	ECCENTRIC STOPPER	偏心ストッパ	1
36		SM-6041202-TP	SCREW M4X0.7 L=12	六角穴ボルト	1
37		182-19204	DW PIN 4X18	DWピン 4 X 1 8	1
38		165-54008	SPRING	引張りばね	1
39		182-17505	TOP PLATE	天板	1
40		165-67802	LINK PLATE	リンク板	1
41		165-72505	PIN	シャッターソレノイドピン	1
42		RE-0250000-K0	E-RING 2.5	E 形止め輪 2. 5	2
43		165-67901	HING SCREW	ヒンジねじ	1
44		165-73305	SLIDER BLOCK	滑り子	1
45		WS-0410002-KN	SPRING WASHER	ばね座金 M 4	2
46		NM-6040001-SC	NUT M4	六角ナット M 4	2
47		SM-6041002-TP	SCREW M4 L=10	六角穴ボルト M 4 X 0. 7 L = 1 0	2
48		WS-0410002-KN	SPRING WASHER	ばね座金 M 4	2
49		WP-0430800-SC	WASHER M4	平座金小形丸 M 4	2
50		GBR-10853000	MAGNET	シャッターマグネット	1
51		165-68206	BRACKET (2)	ブラケット (2)	1
52		165-74204	SUPPORT PLATE	支え板	1
53		WP-0641600-SC	WASHER 6.4X12.5X1.6	平座金	1
54		165-65400	HING PIN (2)	ヒンジピン (2)	2
55		165-65509	HING PIN (1)	ヒンジピン (1)	1
56		GBR-10854000	MAGNET	位置決めマグネット	1
57		WS-0410002-KN	SPRING WASHER	ばね座金 M 4	2
58		WS-0410002-KN	SPRING WASHER	ばね座金 M 4	1
59		SM-6040802-TP	SCREW M4X0.7 L=8	六角穴ボルト	3
60		WS-0410002-KN	SPRING WASHER	ばね座金 M 4	4
61		WP-0430800-SC	WASHER M4	平座金小形丸 M 4	4
62		SM-6041202-TP	SCREW M4X0.7 L=12	六角穴ボルト	1
63		SM-6040802-TP	SCREW M4X0.7 L=8	六角穴ボルト	2
64		WS-0410002-KN	SPRING WASHER	ばね座金 M 4	2
65		WP-0430800-SC	WASHER M4	平座金小形丸 M 4	2
66		NM-6040001-SC	NUT M4	六角ナット M 4	2
67		WS-0410002-KN	SPRING WASHER	ばね座金 M 4	1
68		165-57209	PIN	止め輪用ピン E リングつけ	1
69		RE-0200000-K0	E-RING	E 形止め輪 2	2
70		SM-6061602-TP	SCREW M6 L=16	六角穴ボルト	1
71		WS-0610002-KN	SPRING WASHER 6.1X12.2X1.5	ばね座金 M 6	1
72		GBR-108440A0	BUTTON SENSOR SWITCH ASM.	位置決めボタン検知スイッチ組	1
73		SM-0861201-SA	SCREW M2.6 L=12	トラスねじ M 2. 6 L = 1 2	(1)
74		182-02150	CHECK ASM. A	三つ爪 A 組	1
75		182-04909	CHECK E	爪 E	(1)
76		182-02101	CHECK C	爪 C	(1)
77		182-02200	CHECK D	爪 D	(1)
78		165-72000	PIN	平行ピン	(5)
79		165-65301	STITCH TONGUE LINK	爪リンク	(2)

REF.NO	NOTE	PART NO	DESCRIPTION	品名	Qty
1		182-01962	FEED ACROSS PLATE ASM. A	送り板調整用 A 組	1
2		165-73701	RING	チョイスリング	(1)
3		SM-0040601-SC	SCREW M4X0.7 L=6	トラス小ねじ M 4 X 0. 7 L = 6	(2)
4		182-03307	ADJUSTING PLATE	調整板	(1)
5		SM-4040801-SF	SCREW M4X0.7 L=8	なべ小ねじ M 4 X 0. 7 L = 8	(1)
6		182-01905	FEED PLATE A	送り板 A	(1)
7		182-02002	BUTTON ADJUST A	ボタンアジャスト A	(8)
8		SM-4860501-SC	SCREW M 2.6 X 5	なべ小ねじ M 2. 6 L = 5	(8)
9		WP-0280500-SC	WASHER	平座金小形丸 M 2. 5	(8)
10		182-13454	LOCK SCREW ASM.	ロックねじ組	1
11		182-13405	LOCK COLLAR	ロックカラー	(1)
12		182-13504	LOCK SHAFT	ロック軸	(1)
13		SM-8050502-TP	SCREW M5 L=5	止めねじ	(1)
14		165-73008	COLLAR	皿カラー	2
15		165-71903	CLIP	ゼネバ止め輪	1
16		182-04206	PIN	平行ピン (3 X 18)	1
17		165-69600	GEAR	小歯車	1
18		165-69501	GENEVA	ゼネバ	1
19		SM-6030802-TP	SCREW M3X0.5 L=8	六角穴ボルト M 3 X 0. 5 L = 8	2
20		182-19501	DIVIDING MAIN SHAFT	割出し主軸	1
21		165-70103	WHEEL	ゼネバホイール	1
22		165-70202	SCREW	カムフォロア軸	2
23		165-70301	COLLAR	ゼネバカラー	2
24		NM-6040001-SC	NUT M4	六角ナット M 4	2
25		182-04503	WING BOLT	蝶ボルト	1
26		165-68909	COVER CAP	キャップ (セット)	1
27	#01	182-00352	FEED PLATE CIRCLE 16 ASM.	送り板丸 16 組	1
28		165-72703	METAL	送り歯車メタル	(1)
29		182-00303	FEED PLATE 16	送り板 16	(1)
30		165-68404	FERRULE DISC	受皿	1
31		SM-6052002-TP	SCREW M5 L=20	六角穴ボルト M 5 X 0. 8 L = 20	1
32		WS-0410002-KN	SPRING WASHER	ばね座金 M 4	1
33		165-70707	SENSOR BRACKET	INDEX センサーブラケット	1
34		SM-6040802-TR	SCREW M4X0.7 L=8	六角穴ボルト M 4 X 0. 7 L = 8	1
35		WS-0410002-KN	SPRING WASHER	ばね座金 M 4	1
36		WP-0430800-SC	WASHER M4	平座金小形丸 M 4	1
37		165-70905	STAND PLATE (1)	台座 (1)	1
38		SM-6041202-TP	SCREW M4X0.7 L=12	六角穴ボルト	1
39		SM-6051202-TP	SCREW M5X0.8 L=12	六角穴ボルト M 5 X 0. 8 L = 12	1
40		182-19600	GENEVA HOUSE	ゼネバハウス	1
41		SM-6051602-TP	SCREW M5X0.8 L=16	六角穴ボルト M 5 X 0. 8 L = 16	3
42		SB-1100004-00	BALL BEARING	ボールベアリング	1
43		165-62001	WORM WHEEL	ウォームホイール	1
44		SM-8050602-TP	SCREW M5 L=6	止めねじ M 5 X 0. 8 L = 6	2
45		165-71804	BEARING A	軸受 A	1
46		165-73909	THRUST COLLAR	INDEX カラー	2
47		GBR-108560A0	DC MOTOR ASM.	インデックス DC モータ組	1
48		165-70509	THRUST COLLAR	INDEX モーターカラー	1
49		165-71408	NEEDLE BEARING	シェル形ニードルベアリング	1
50		182-12902	SENSOR COVER	インデックスセンサカバー	1
51		165-70608	SHAFT	手動旋回軸	1
52		SM-8040402-TP	SCREW M4X0.7 L=4	止めねじ M 4 X 0. 7 L = 4	2
53	#03	182-01103	HOLDING PLATE (SMALL)	受皿 (小)	1
54		SM-6051202-TP	SCREW M5X0.8 L=12	六角穴ボルト M 5 X 0. 8 L = 12	1
55		SM-6041002-TP	SCREW M4 L=10	六角穴ボルト M 4 X 0. 7 L = 10	1
56		B2107-816-000	WASHER	ロッド座金	1
57		SM-6030802-TP	SCREW M3X0.5 L=8	六角穴ボルト M 3 X 0. 5 L = 8	4
58		WS-0310002-KN	SPRING WASHER M3	ばね座金 3. 1 X 5. 9 X 0. 7	4
59		WP-0320500-SC	WASHER M3	平座金小形丸 M 3	4
60	#02	165-68651	FEED PLATE 22B ASM.	送り板 22 B 組	1
61	#02	165-68602	FEED PLATE 22B	送り板 22 B	(1)
62		165-72703	METAL	送り歯車メタル	(1)
63	#03	182-00956	FEED PLATE CIRCLE 13.5 ASM.	送り板丸 13. 5 組	1
64	#03	182-00907	FEED PLATE 12.5	送り板 12. 5	(1)
65		165-72703	METAL	送り歯車メタル	(1)
66		GBR-108450A0	INDEX STARTING SWITCH ASM.	インデックス原点スイッチ組	1
67		SM-0861201-SA	SCREW	トラスねじ M 2. 6 L = 12	(1)
68		165-69204	REST	皿	1
69		SM-1041201-SC	SCREW M4 L=12	皿小ねじ M 4 X 0. 7 L = 12	2
70		SM-1040601-SC	SCREW M4X0.7 L=6	皿小ねじ M 4 X 0. 7 L = 6	1
71		182-18008	SHAFT (2)	軸 (2)	1
72		165-71606	WORM GEAR	ゼネバウォームギア	1
		NOTE(注記)	#01....FOR SMALL-SIZED BUTTON #02....FOR MEDIUM-SIZED BUTTON #03....OPTIONAL PARTS	小ボタン用 中ボタン用 オプション部品	

11. FEEDER BALL COMPONENTS

フィダーボール関係

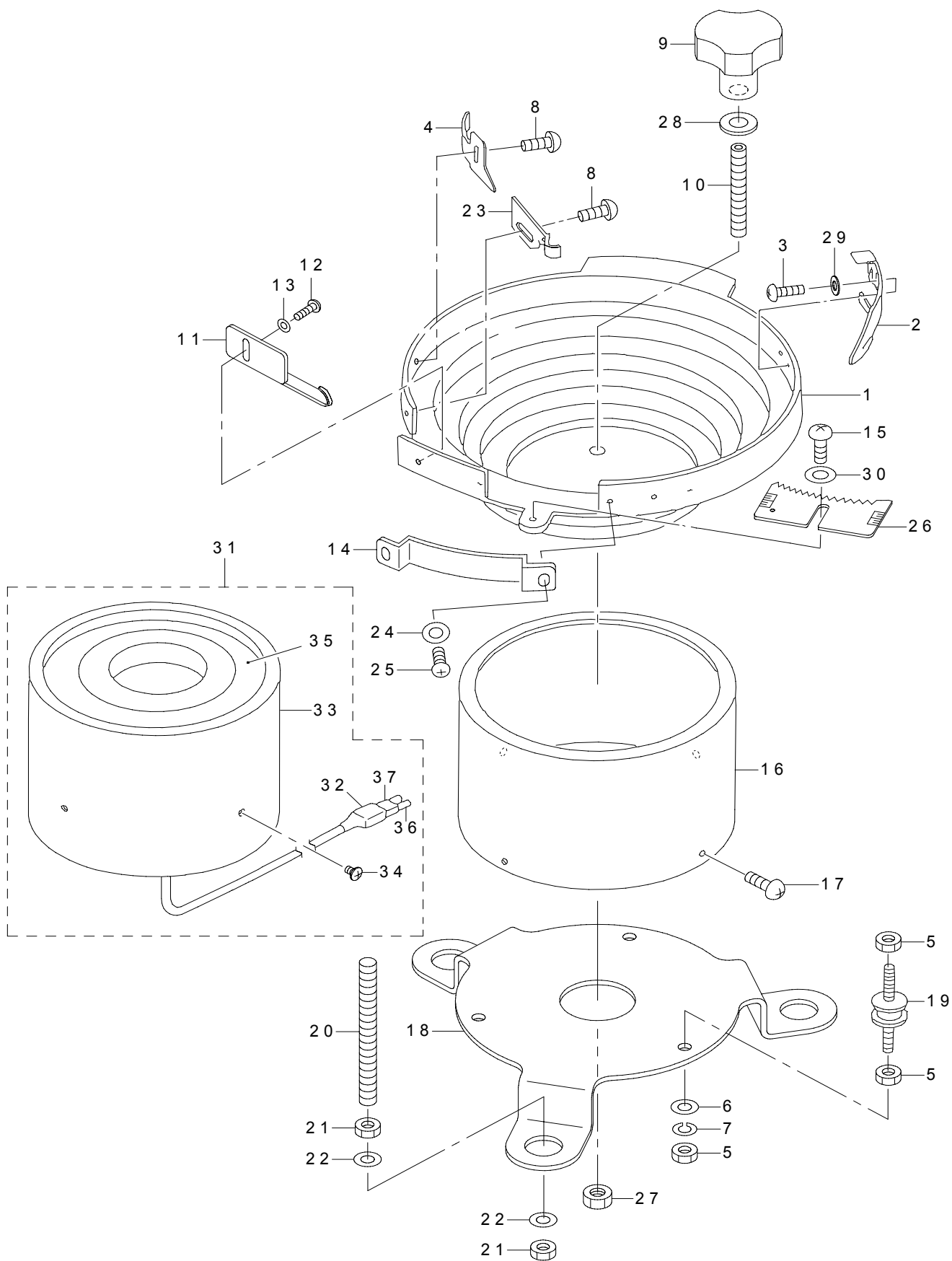

REF.NO	NOTE	PART NO	DESCRIPTION	品名	Qty
1		165-77009	FEEDER BOWL	フィーダーボール	1
2		GBR-01426000	GUIDE PLATE	案内板	1
3		SS-4110815-SP	SCREW 11/64-40 L=8	なべねじ 11/64-40 L=8	2
4		GBR-01441000	BUTTON STANDING PREVENT PLATE	ボタン立ち防止板	1
5		NM-6060001-SC	NUT M6	六角ナット M6 1種	9
6		WP-0641600-SC	WASHEW 6.4X12.5X1.6	平座金	3
7		WS-0610002-KN	SPRING WASHER 6.1X12.2X1.5	ばね座金 M6	3
8		SM-4040801-SN	SCREW M4 L=8	なべ小ねじ M4 X 0.7 L=8	2
9		182-04602	BOWL FIXING KNOB	ボウル固定ノブ	1
10		SM-8086012-TP	SCREW M8 L=60	止めねじ M8 L=60	1
11		165-77504	SELECTOR PLATE	整別板	1
12		SM-4040801-SN	SCREW M4 L=8	なべ小ねじ M4 X 0.7 L=8	1
13		WP-0430800-SC	WASHER M4	平座金小形丸 M4	1
14		GBR-01428000	GUIDE PLATE	ガイド板	1
15		SM-4051001-SN	SCREW M5	なべ小ねじ M5 X 0.8 L=10	1
16		165-77207	P/F COVER	P/Fカバー	1
17		SM-0040601-SC	SCREW M4X0.7 L=6	トラス小ねじ M4 X 0.7 L=6	4
18		400-14217	P/F INSTALLING BASE	P/F取付板	1
19		165-79203	RUBBER VIBRATION INSULATOR	防振ゴム	3
20		165-77306	MOUNTING BOLT	六角棒	3
21		NM-6080001-SC	NUT M8X1.25	六角ナット M8 1種	6
22		165-77405	WASHER	座金	6
23		182-02408	BUTTON GUIDE A	ボタンガイド A	1
24		WP-0320500-SC	WASHER M3	平座金小形丸 M3	2
25		SM-4030601-SN	SCREW M3 X 6	なべ小ねじ M3 X 0.5 L=6	2
26		GBR-014220A0	SELECTION PLATE ASM. (SMALL)	選別板小組	1
27		NM-6080001-SC	NUT M8X1.25	六角ナット M8 1種	1
28		WP-0841601-SC	WASHER 8.4X17.4X1.6	平座金みがき丸 M8	1
29		WP-0450801-SD	WASHER 4.5X10X0.8	平座金 4.5 X 10 X 0.8	2
30		WP-0531000-SC	WASHER 5.3X10X1	平座金 5.3 X 10 X 1	1
31	#01	GBR-107910A0	PARTS FEEDER ALL ASM.	パーツフィーダー組	1
32		HK-0044900-20	CONNECTOR COVER	コネクタカバー	(1)
33		165-77207	P/F COVER	P/Fカバー	(1)
34		SM-0040601-SC	SCREW M4X0.7 L=6	トラス小ねじ M4 X 0.7 L=6	(4)
35		GBR-10791000	PARTS FEEDER	パーツフィーダー	(1)
36		HK-0044400-20	2-POLE RECEPTACLE	リセプタクル 2P	(1)
37		D6042-555-B00	PIN TERMINAL FEMALE	ピンターミナルメス	(2)
		NOTE(注記)	#01....FOR USE IN JAPAN AND GENERAL EXPORT	日本,一般輸出用	

12. TABLE & COVER COMPONENTS

脚卓・カバー関係

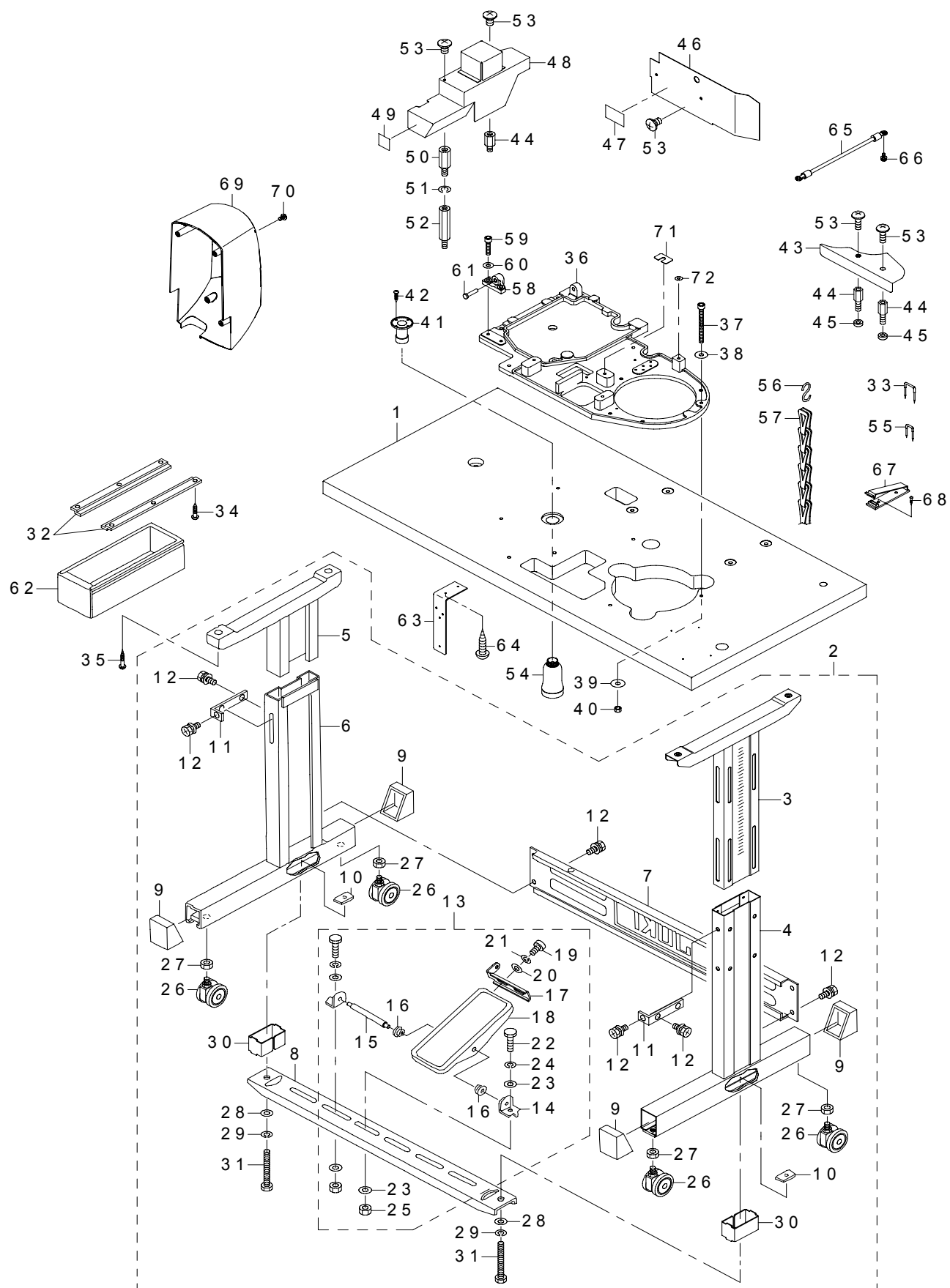

REF.NO	NOTE	PART NO	DESCRIPTION	品名	Qty
1	☆	401-48338	TABLE	テーブル	1
2	#02	141-91951	T-STAND COMPL.	T 脚結合	1
3		141-18152	UPPER STAND ASM. RIGHT	上脚結合 (右)	(1)
4		141-18251	STAND ASM. RIGHT	支柱結合 (右)	(1)
5		B8101-210-AAB	UPPER STAND ASM.	上脚結合	(1)
6		B8105-210-AAA	STAND ASM.	支柱結合	(1)
7		111-58300	STAND SIDE SUPPORT	横支柱	(1)
8		111-58409	STAND SIDE SUPPORT	下支柱	(1)
9		111-58607	RUBBER CAP	脚土台キャップ	(4)
10		170-07402	NUT	4 4 角ナット	(2)
11		111-58516	UPPER STAND PLATE	上脚止め板	(2)
12		SL-9082091-SE	WASHER HEXAGONAL BOLT	座金付き六角ボルト	(10)
13		138-17754	Z-STAND PEDAL ASM.	Z 脚用ペダル (結合)	(1)
14		111-59001	PEDAL SHAFT BRACKET	踏板軸受	(2)
15		B8153-771-000	PEDAL CONNECTING ROD	ペダル軸	(1)
16		D8113-555-B00	PEDAL BUSHING	踏板ブッシュ	(2)
17		GPF-06080000	PEDAL ADJUSTING PLATE	踏板調節板	(1)
18		GPF-060600A0	PEDAL ASM.	ペダル (結合)	(1)
19		SM-9061203-SE	SCREW M6 L=12	六角ボルト M 6 L = 12	(2)
20		WP-0671016-SE	WASHER 6.7X13X1	平座金 6. 7 X 13 X 1	(2)
21		WS-0621210-KR	SPRING WASHER 6.2X11.4X1.2	ばね座金 6. 2 X 11. 4 X 1. 2	(2)
22		SM-9082023-SE	SCREW M8 L=20	六角ボルト M 8 L = 20	(2)
23		WP-0871602-SE	WASHER 8.7X18X1.6	平座金 8. 7 X 18 X 1. 6	(4)
24		WS-0861410-KR	SPRING WASHER 8.6X15X1.4	ばね座金 8. 6 X 15 X 1. 4	(2)
25		NM-6080721-SE	NUT M8	六角ナット M 8	(2)
26		B8150-210-000	CASTER	テーブルキャスタ	(4)
27		NM-6120003-SE	NUT M12	六角ナット M 12 3種	(4)
28		WP-0871602-SE	WASHER 8.7X18X1.6	平座金 8. 7 X 18 X 1. 6	(2)
29		WS-0861410-KR	SPRING WASHER 8.6X15X1.4	ばね座金 8. 6 X 15 X 1. 4	(2)
30		111-59506	STRUT AUXILIARY PLATE	下支柱補助板	(2)
31		SM-9086523-SE	HEXAGONAL BOLT	六角ボルト	(2)
32	#03	111-55207	DRAWER SUPPORT	抽斗支え	2
33		D8204-555-D00	DRAWER STOPPER	抽斗ストッパー	3
34	#03	SK-3311601-SE	WOOD SCREW D=3.1 L=16	丸木ねじ D = 3. 1 L = 16	6
35		SK-3483201-SE	WOOD SCREW D=4.8 L=32	丸木ねじ D = 4. 8 L = 32	4
36		400-14216	BASE	ベース	1
37		SM-6066552-TP	BOLT	六角穴ボルト	6
38		WP-0612056-SD	WASHER 6.1X18.5X2	平座金 6. 1 X 18. 5 X 2	6
39		WP-0651646-SC	WASHER	平座金	6
40		NM-6060001-SC	NUT M6	六角ナット M 6 1種	6
41		B8202-205-000	OIL MANAGEMENT	油抜き	1
42		SK-3311601-SE	WOOD SCREW D=3.1 L=16	丸木ねじ D = 3. 1 L = 16	4
43		182-22604	FRONT COVER A	前面カバー A	1
44		HX-0033900-00	STUD	基板パーツ	3
45		B3052-816-000	WASHER	駆動受座金	2
46		400-14221	FRONT COVER B	前面カバー B	1
47	#01	CM-3002002-B1	SAFETY LABEL 13	安全ラベル 13	1
48		400-14220	HEAD COVER	頭部カバー	1
49		165-86505	DANGER PREVENTION STICKER	危険防止ステッカー	1
50		HX-0033900-0F	SPACER	スペーサ	1
51		WS-0410002-KN	SPRING WASHER	ばね座金 M 4	1
52		HX-0033900-0B	BOARD PARTS	基板パーツ	1
53		SM-0040601-SA	SCREW	トラスねじ M 4 L = 6	6
54		B9121-012-000	OIL CAN	油びん	1
55		MAO-11532000	CORD STAPLE	コードステップル	11
56	#03	131-60304	S SHAPED HOOK	S 形金具	2
57	#03	260-37903	CHAIN	鎖	1
58		GBR-25006000	HEAD FIXING HINGE	頭部固定ヒンジ	1
59		SM-6062502-TP	SCREW M6 L=25	六角穴ボルト M 6 L = 25	2
60		WP-0611626-SP	WASHER 15X6X1.6	平座金	2
61		D2431-555-B00	THREAD TRIMMER SHAFT	糸切り腕軸	2
62	#03	111-55108	DRAWER	引き出し	1
63		B5542-205-000	TERMINAL BRACKET	端子台ブラケット	1
64		SK-3311601-SE	WOOD SCREW D=3.1 L=16	丸木ねじ D = 3. 1 L = 16	2
65		GBR-308650A0	BASE EARTH CORD ASM.	ベースアース線組	1
66		SL-4041091-SC	SCREW M4 L=10	なべ小ねじセムス M 4 X 0. 7 L = 10	1
67		M9640-510-00A	CABLE CLIP	ケーブルクリップ	1
68		SK-3382001-SE	SCREW D=3.8 L=20	丸木ねじ D = 3. 8 L = 20	2
69		400-06475	MOTOR COVER	モーターカバー	1
70		SM-5040855-SN	SCREW	バインドねじ	4
71		GBR-25010000	BODY FRAME SPACER A	本体フレームスペーサー A	3
72		WP-0621036-SP	WASHER	平座金	1
		NOTE(注記)	#01....FOR USE IN JAPAN AND GENERAL EXPORT	日本, 一般輸出用	
			#02....OPTIONAL PARTS	オプション部品	
			#03....ACCESSORIE PARTS	付属品	

13. BR CONTROL BOX COMPONENTS (FOR USE IN JAPAN AND GENERAL EXPORT)

B R 電装関係 (日本, 一般輸出用)

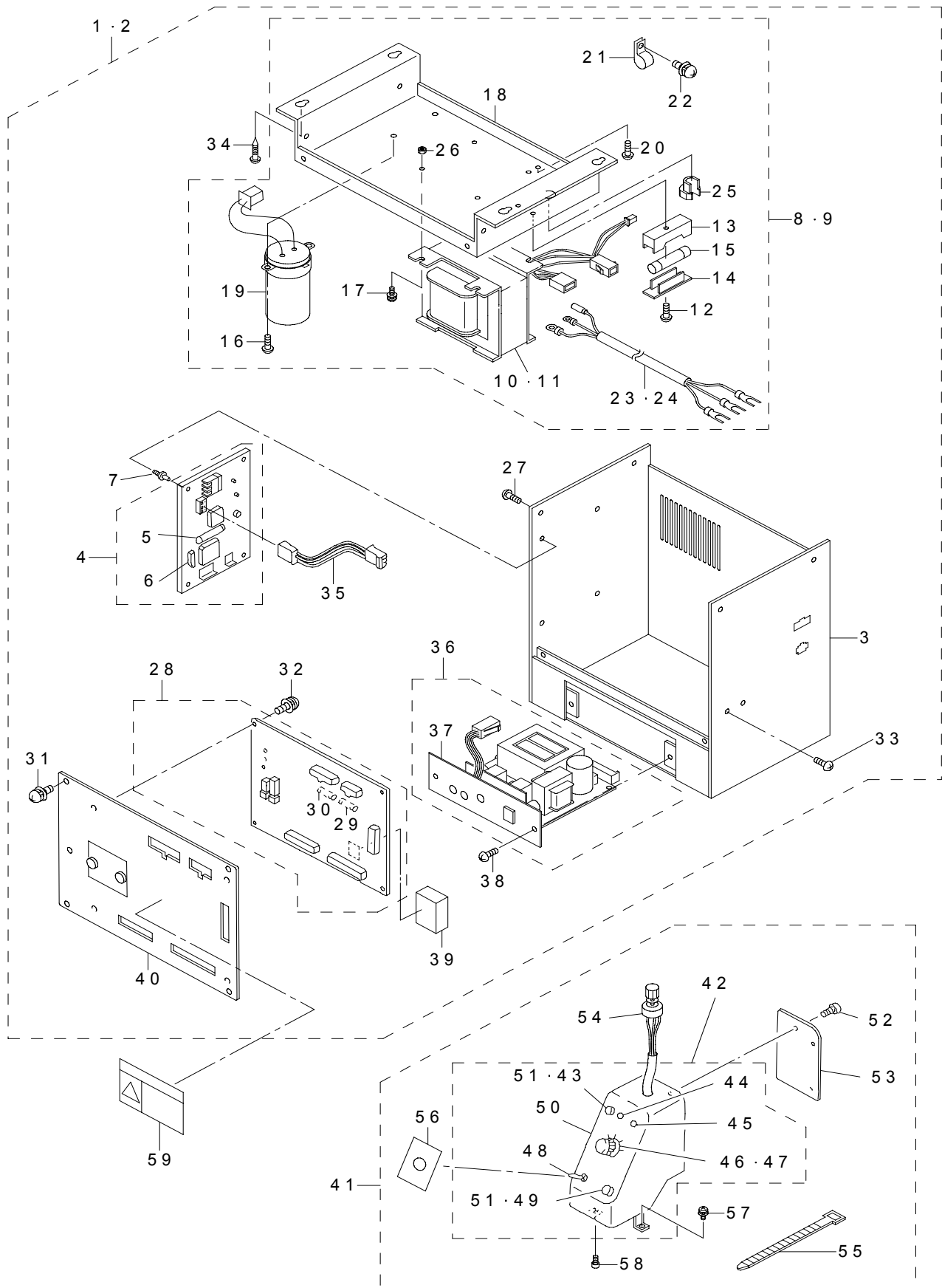

REF.NO	NOTE	PART NO	DESCRIPTION	品名	Qty
1	#01	400-14506	CONTROL BOX B ASM.	電装ボックス B 組	1
2	#02	400-14495	CONTROL BOX A ASM.	電装ボックス A 組	1
3		GBR-107240A0	CONTROL BOX FRAME BODY ASM.	電装ボックスフレーム本体組	(1)
4		GBR-107610A0	POWER BOARD	電源基板組	(1)
5		E9613-601-000	FUSE 2A	ガラス管ヒューズ2 A	(1)
6		HA-0029800-00	BREAKER 5A	ブレーカー5 A	(1)
7		HX-0022800-0A	SPACER	スペーサ	(4)
8	#01	GBR-107460AB	TRANS BASE B COMPLE.	トランスベース B 総組	(1)
9	#02	GBR-107460AA	TRANS BASE A COMPLE.	トランスベース A 総組	(1)
10	#02	GBR-107480AA	TRANS A ASM.	トランス A 組	(1)
11	#01	GBR-107480AB	TRANS B ASM.	トランス B 組	(1)
12		SM-4041001-SC	SCREW M4X0.7 L=10	なべ小ねじ M 4 X 0. 7 L = 1 0	(1)
13		HF-0051110-00	FUSE HOLDER	ヒューズホルダー	(1)
14		HF-0051110-0B	FUSE HOLDER COVER	ヒューズホルダーカバー	(1)
15		E9613-601-000	FUSE 2A	ガラス管ヒューズ2 A	(1)
16		SL-4030681-SC	SCREW M3 L=6	座金付きなべ小ねじ M 3 L = 6	(2)
17		SL-4041291-SC	SCREW M4 L=12	なべ小ねじセムス M 4 L = 1 2	(4)
18		GBR-10747000	TRANSFORMER BASE	トランスベース	(1)
19		GBR-107430A0	CONDENSER ASM.	コンデンサ組	(1)
20		SL-4040891-SC	SCREW M4 L=8	座金付きなべ小ねじ M 4 L = 8	(2)
21		HX-0015000-0B	CABLE CLIP	ケーブルクリップ	(1)
22		SL-4030881-SC	SCREW M3X8	なべ小ねじセムス M 3 X 0. 5 L = 8	(1)
23	#02	GBR-107450A0	AC INPUT POWER CABLE CORD ASM.	A C 入力電源コード組	(1)
24	#01	GBR-107440A0	AC INPUT POWER CABLE CORD ASM.	A C 入力電源コード組 B	(1)
25		HX-0009800-00	CORD BUSH	コードブッシュ	(1)
26		NM-6040001-SF	NUT M4	六角ナット M 4 X 0. 7 1種	(4)
27		SL-4040891-SC	SCREW M4 L=8	座金付きなべ小ねじ M 4 L = 8	(4)
28		GBR-107510A0	CPU BOARD ASM.	CPU 基板組	(1)
29		HF-0084020-P0	FUSE 2A	ヒューズ2 A	(1)
30		HF-0084063-P0	FUSE	ヒューズ	(1)
31		SL-4040891-SC	SCREW M4 L=8	座金付きなべ小ねじ M 4 L = 8	(4)
32		SL-4030681-SC	SCREW M3 L=6	座金付きなべ小ねじ M 3 L = 6	(4)
33		SL-4040891-SC	SCREW M4 L=8	座金付きなべ小ねじ M 4 L = 8	(2)
34		SK-3452501-SE	SCREW D=4.5 L=25	丸木ねじ D = 4. 5 L = 2 5	(4)
35		GBR-107720A0	CPU BOARD POWER CORD ASM.	CPU 基板電源コード組	(1)
36		GBR-107740A0	P/F CONTROLLER ASM.	P / F コントローラ組	(1)
37		GBR-10775000	P/F PANEL	P / F パネル	(1)
38		SM-5040601-SC	SCREW M4X0.7 L=6	バインド小ねじ M 4 X 0. 7 L = 6	(2)
39		HL-0087301-40	IC	I C	(1)
40		GBR-207340A0	CONTROL BOX FRAME COVER ASM.	電装ボックスフレーム蓋組	(1)
41		GBR-30784AA0	OPERATION PANEL WHOLE ASM. (A)	操作パネル総組 (A)	1
42		GBR-107850A0	PANEL ASM.	パネル組	(1)
43		HA-0019100-1B	OPERATION BUTTON	操作部ボタン	(1)
44		HG-0029100-0A	LED (GREEN)	L E D (緑)	(1)
45		HG-0029100-00	LAMP	ダイオード	(1)
46		HA-0029000-00	DIP SWITCH	ディップスイッチ	(1)
47		HX-0011400-0A	KNOB	つまみ	(1)
48		MAO-14506000	SWITCH	ボタン穴切り換えスイッチ	(1)
49		HA-0019100-1C	SWITCH KNOB BLACK	スイッチボタン (黒)	(1)
50		GBR-10786000	PANEL BOX	パネルボックス	(1)
51		HA-0019100-00	PUSH SWITCH 3 TERMINAL	プッシュスイッチ3端子	(2)
52		SL-4030681-SC	SCREW M3 L=6	座金付きなべ小ねじ M 3 L = 6	(3)
53		GBR-10782000	PANEL BOX BACK COVER	パネルボックス裏蓋	(1)
54		GBR-107870A0	VOLUME ASM.	ボリューム組	(1)
55		EA-9500B01-00	CABLE BAND	束線バンド	(1)
56		GBR-30788000	SHEEL	モード切替シール	(1)
57		SL-4041091-SC	SCREW M4 L=10	なべ小ねじセムス M 4 X 0. 7 L = 1 0	(1)
58		SM-6040802-TN	SCREW	六角穴ボルト M 4 X 0. 7 L = 8	(1)
59	#03	CM-3001001-01	DANGER LABEL (SMALL)	電撃危険ラベル (小)	1
		NOTE(注記)	#01....FOR 220V,240V #02....FOR 100V,200V #03....FOR USE IN JAPAN	2 2 0 V, 2 4 0 V 用 1 0 0 V, 2 0 0 V 用 日本用	

14. BR CONTROL BOX COMPONENTS (FOR EUROPE)

BR 電装関係 (ヨーロッパ用)

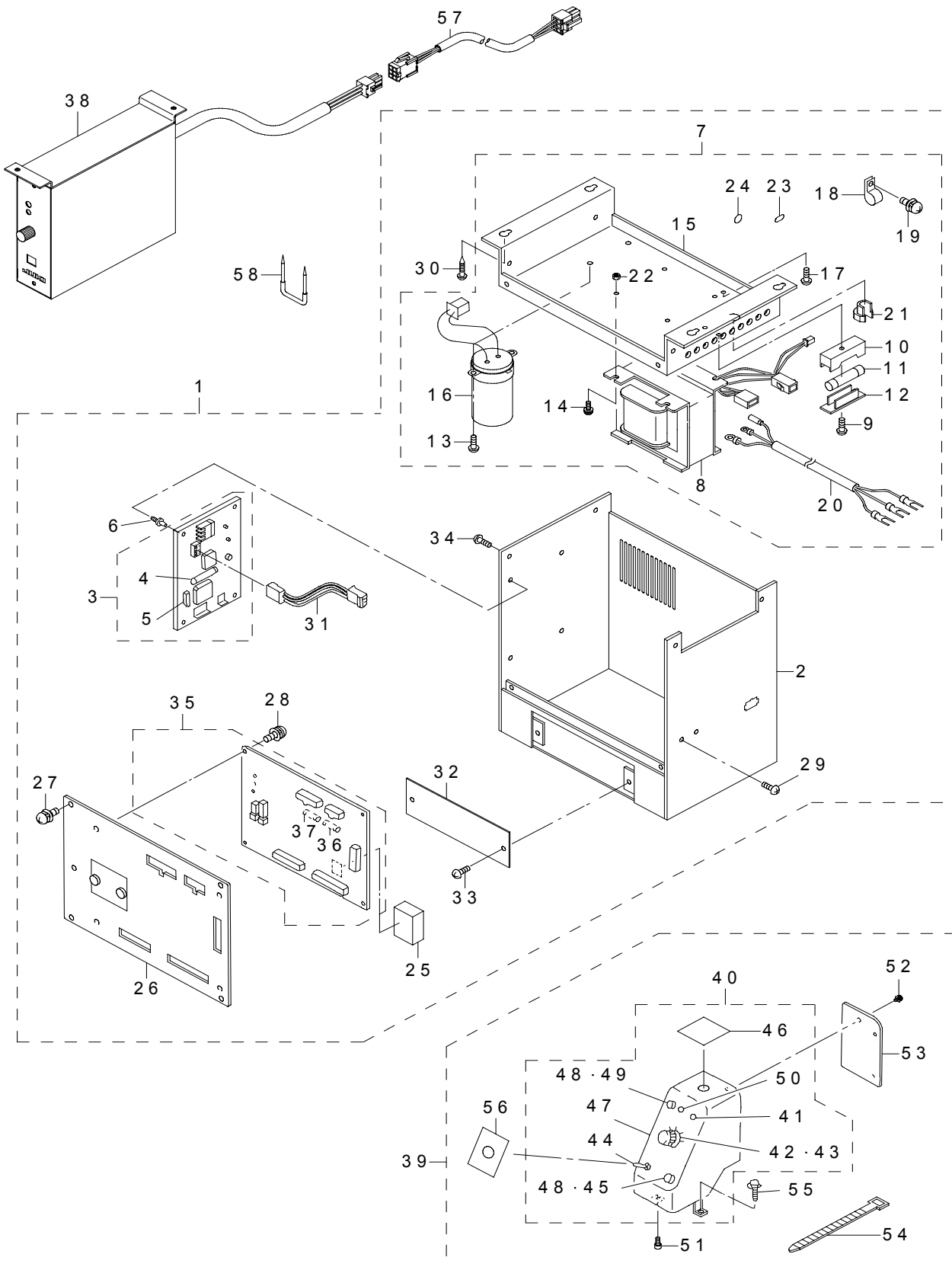

REF.NO	NOTE	PART NO	DESCRIPTION	品名	Qty
1		400-14526	CONTROL BOX C ASM.	電装ボックス C 組	1
2		GBR-107240AC	CONTROL BOX FRAME BODY C ASM.	電装ボックスフレーム本体 C 組	(1)
3		GBR-107610A0	POWER BOARD	電源基板組	(1)
4		E9613-601-000	FUSE 2A	ガラス管ヒューズ2 A	(1)
5		HA-0029800-00	BREAKER 5A	ブレーカー5 A	(1)
6		HX-0022800-0A	SPACER	スペーサ	(4)
7		GBR-107460AC	TRANS BASE C COMPLE.	トランスベース C 総組	(1)
8		GBR-107480AC	TRANS C ASM.	トランス C 組	(1)
9		SM-4041001-SC	SCREW M4X0.7 L=10	なべ小ねじ M 4 X 0. 7 L = 1 0	(1)
10		HF-0051110-00	FUSE HOLDER	ヒューズホルダー	(1)
11		E9613-601-000	FUSE 2A	ガラス管ヒューズ2 A	(1)
12		HF-0051110-0B	FUSE HOLDER COVER	ヒューズホルダーカバー	(1)
13		SL-4030681-SC	SCREW M3 L=6	座金付きなべ小ねじ M 3 L = 6	(2)
14		SL-4041291-SC	SCREW M4 L=12	なべ小ねじセムス M 4 L = 1 2	(4)
15		GBR-10747000	TRANSFORMER BASE	トランスベース	(1)
16		GBR-107430A0	CONDENSER ASM.	コンデンサ組	(1)
17		SL-4040891-SC	SCREW M4 L=8	座金付きなべ小ねじ M 4 L = 8	(3)
18		HX-0015000-0B	CABLE CLIP	ケーブルクリップ	(1)
19		SL-4030881-SC	SCREW M3X8	なべ小ねじセムス M 3 X 0. 5 L = 8	(1)
20		GBR-107440A0	AC INPUT POWER CABLE CORD ASM.	AC 入力電源コード組 B	(1)
21		HX-0009800-00	CORD BUSH	コードブッシュ	(1)
22		NM-6040001-SF	NUT M4	六角ナット M 4 X 0. 7 1種	(4)
23		CM-2001000-01	PE MARK LABEL	PE マークシール	(1)
24		100-04109	GROUND MARK	グラウンドマーク	(1)
25		HL-0087301-43	IC	IC	(1)
26		GBR-207340A0	CONTROL BOX FRAME COVER ASM.	電装ボックスフレーム蓋組	(1)
27		SL-4040891-SC	SCREW M4 L=8	座金付きなべ小ねじ M 4 L = 8	(4)
28		SL-4030681-SC	SCREW M3 L=6	座金付きなべ小ねじ M 3 L = 6	(4)
29		SL-4040891-SC	SCREW M4 L=8	座金付きなべ小ねじ M 4 L = 8	(2)
30		SK-3452501-SE	SCREW D=4.5 L=25	丸木ねじ D = 4. 5 L = 2 5	(4)
31		GBR-107720A0	CPU BOARD POWER CORD ASM.	CPU 基板電源コード組	(1)
32		GBR-10726000	BLIND PLATE	ブラインドプレート	(1)
33		SM-5040601-SC	SCREW M4X0.7 L=6	バンド小ねじ M 4 X 0. 7 L = 6	(2)
34		SL-4040891-SC	SCREW M4 L=8	座金付きなべ小ねじ M 4 L = 8	(4)
35		GBR-107510A0	CPU BOARD ASM.	CPU 基板組	(1)
36		HF-0084020-P0	FUSE 2A	ヒューズ2 A	(1)
37		HF-0084063-P0	FUSE	ヒューズ	(1)
38		GBR-108010A0	P/F CONTROLLER ASM.	P / F コントローラ総組	1
39		400-16644	OPERATION PANEL WHOLE ASM. C	操作パネル総組 C	1
40		GBR-107850AC	PANEL C ASM.	パネル C 組	(1)
41		HG-0029100-00	LAMP	ダイオード	(1)
42		HA-0029000-00	DIP SWITCH	ディップスイッチ	(1)
43		HX-0011400-0A	KNOB	つまみ	(1)
44		MAO-14506000	SWITCH	ボタン穴切り換えスイッチ	(1)
45		HA-0019100-1C	SWITCH KNOB BLACK	スイッチボタン (黒)	(1)
46		GBR-10728000	BLANK STICKER B	ブランクシール B	(1)
47		GBR-10786000	PANEL BOX	パネルボックス	(1)
48		HA-0019100-00	PUSH SWITCH 3 TERMINAL	プッシュスイッチ3端子	(2)
49		HA-0019100-1B	OPERATION BUTTON	操作部ボタン	(1)
50		HG-0029100-0A	LED (GREEN)	LED (緑)	(1)
51		SM-6040802-TN	SCREW	六角穴ボルト M 4 X 0. 7 L = 8	(1)
52		SL-4030681-SC	SCREW M3 L=6	座金付きなべ小ねじ M 3 L = 6	(3)
53		GBR-10782000	PANEL BOX BACK COVER	パネルボックス裏蓋	(1)
54		EA-9500B01-00	CABLE BAND	束線バンド	(1)
55		SL-4041091-SC	SCREW M4 L=10	なべ小ねじセムス M 4 X 0. 7 L = 1 0	(1)
56		GBR-30788000	SHEEL	モード切替シール	(1)
57		GBR-250810A0	CABLE ASM.	P / F コントローラ中継ケーブル組	1
58		MAO-11532000	CORD STAPLE	コードステップル	4

15. BR POWER SUPPLY COMPONENTS

BR 入出力関係

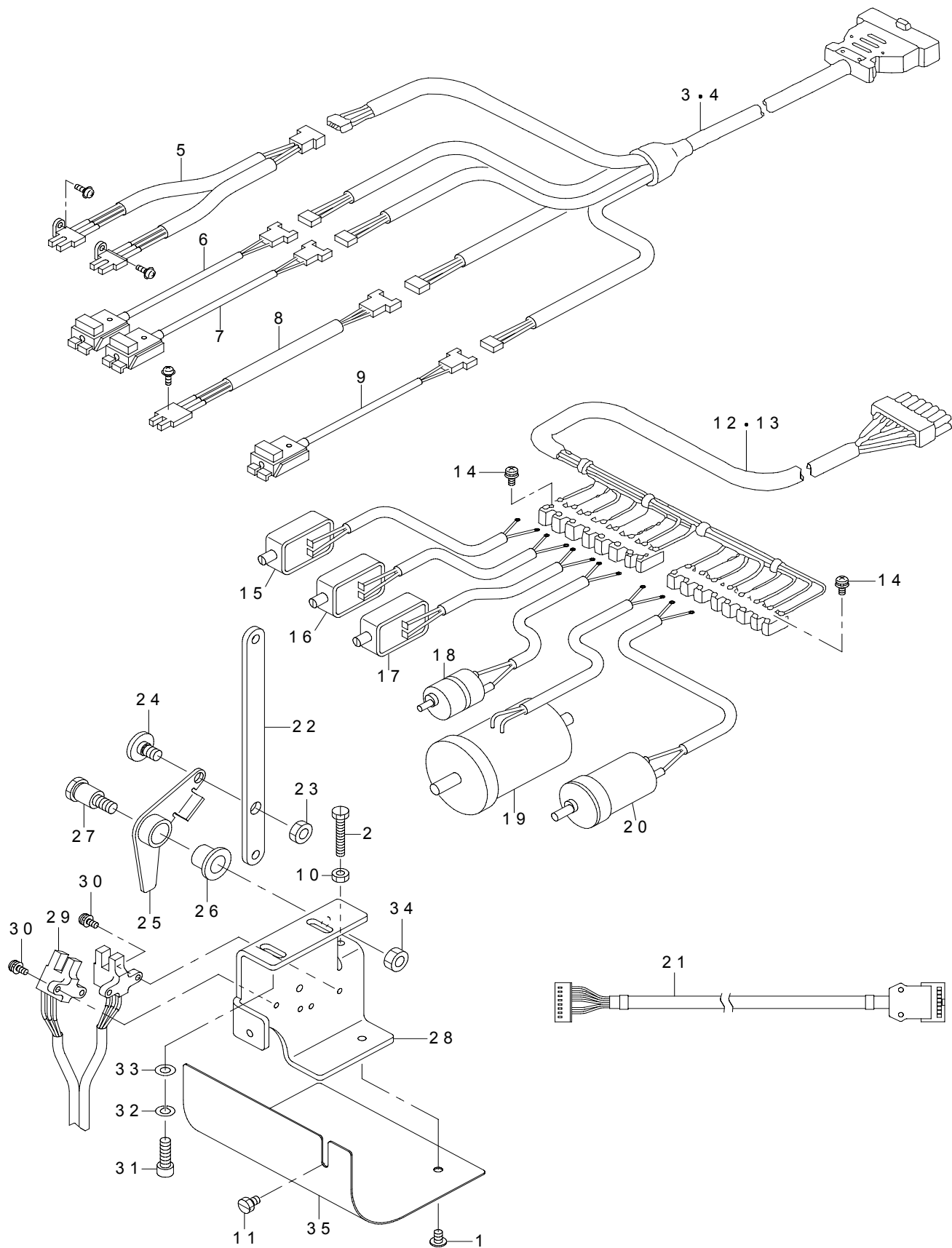

REF.NO	NOTE	PART NO	DESCRIPTION	品名	Qty
1		SM-0040601-SC	SCREW M4X0.7 L=6	トラス小ねじ M 4 X 0. 7 L = 6	1
2		SM-9042510-SC	SCREW M4X0.7 L=25	六角ボルト M 4 X 0. 7 L = 2 5	1
3	#01	GBR-108460A0	SENSOR CONNECTING CABLE ASM.	センサ中継ケーブル組	1
4	#02	GBR-108460AC	SENSOR CONNECTING CABLE ASM.	センサ中継ケーブル C 組	1
5		GBR-108420A0	START SWITCH ASM.	スタートスイッチ組	1
6		GBR-108430A0	RUB COMPLETION SWITCH ASM.	すりもみ完了スイッチ組	1
7		GBR-108440A0	BUTTON SENSOR SWITCH ASM.	位置決めボタン検知スイッチ組	1
8		GBR-108470A0	TURNING ARM HOME POSITION SENSOR ASM.	旋回アーム原点センサ組	1
9		GBR-108450A0	INDEX STARTING SWITCH ASM.	インデックス原点スイッチ組	1
10		NM-6040001-SC	NUT M4	六角ナット M 4	1
11		SM-9040600-SP	HEAXGON BOLT	六角ボルト	1
12	#01	GBR-108580A0	STARTING MAGNET CABLE ASM.	出力中継ケーブル組	1
13	#02	GBR-108580AC	STARTING MAGNET CABLE ASM.	出力中継ケーブル C 組	1
14		SL-4030881-SC	SCREW M3X8	なべ小ねじセムス M 3 X 0. 5 L = 8	2
15		GBR-10852000	MAGNET	すりもみ下降マグネット	1
16		GBR-10853000	MAGNET	シャッターマグネット	1
17		GBR-10854000	MAGNET	位置決めマグネット	1
18		GBR-108550A0	DC MOTOR ASM.	すりもみ DC モーター組	1
19		GBR-108590A0	DC MOTOR ASM.	旋回アーム DC モーター組	1
20		GBR-108560A0	DC MOTOR ASM.	インデックス DC モーター組	1
21		400-12037	LKA-BR RELAY CABLE ASM.	L K A - B R 中継ケーブル組	1
22		400-14219	SWITCH LINK	スイッチリンク	1
23		NS-6150430-SP	NUT 15/64-28	六角ナット 1 5 / 6 4 - 2 8	1
24		SD-0700332-SP	HINGE SCREW D=7 H=3.5	段ねじ D = 7 H = 3. 5	1
25		182-19907	TWO-STEP SWITCH LEVER	二段スイッチレバー	1
26		165-83403	METAL	含油メタル	1
27		165-82504	SCREW	二段スイッチねじ	1
28		165-82603	SWITCH BRACKET	二段スイッチブラケット	1
29		GBR-108420A0	START SWITCH ASM.	スタートスイッチ組	1
30		SL-4030881-SC	SCREW M3X8	なべ小ねじセムス M 3 X 0. 5 L = 8	4
31		SM-6051602-TP	SCREW M5X0.8 L=16	六角穴ボルト M 5 X 0. 8 L = 1 6	2
32		WS-0510002-KN	SPRING WASHER	ばね座金 5. 1 X 9. 2 X 1. 3	2
33		WP-0531000-SC	WASHER 5.3X10X1	平座金 5. 3 X 1 0 X 1	2
34		NM-6060001-SC	NUT M6	六角ナット M 6 1種	1
35		165-82702	SWITCH COVER	二段スイッチカバー	1
		NOTE(注記)	#01....FOR USE IN JAPAN AND GENERAL EXPORT	日本, 一般輸出用	
			#02....FOR EUROPE	ヨーロッパ用	

16. CONTROL BOX COMPONENTS

電装ボックス関係

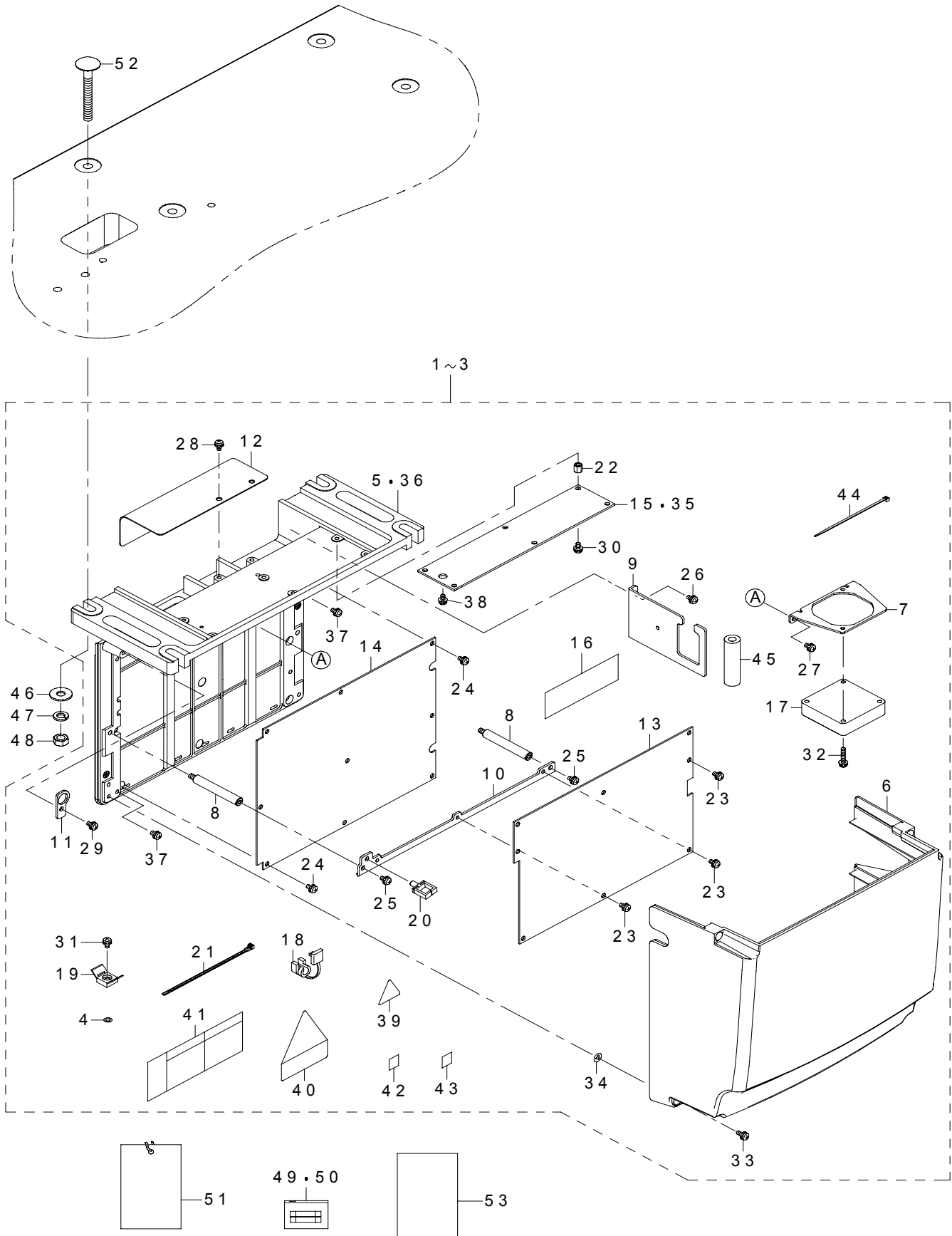

REF.NO	NOTE	PART NO	DESCRIPTION	品名	Qty
1	#01	401-42663	CTL BOX A ASM.	電装ボックス A 組	1
2	#02	401-42664	CTL BOX B ASM.	電装ボックス B 組	1
3	#03	401-42665	CTL BOX C ASM.	電装ボックス C 組	1
4	#05	WP-0430800-SC	WASHER M4	平座金小形丸 M 4	(1)
5	#05	401-43989	FRAME B	電装筐体 3相	(1)
6		401-14136	COVER	電装カバー	(1)
7		401-15874	FAN PLATE	ファン取付板	(1)
8		401-43990	STUD	電装スタッド	(2)
9		401-15876	PLATE B	コード出口板	(1)
10		401-15877	MAIN PLATE	メイン基板取付板	(1)
11		401-15878	PLATE C	電源コード取付板	(1)
12		401-15879	FAN COVER	ファンカバー	(1)
13		401-37360	MAIN PCB ASSY	MAIN 基板組	(1)
14		401-42267	SDC PCB ASSY	SDC 基板組	(1)
15	#02	401-05465	FLT-T PCB ASSY	FLT-T 基板組	(1)
16		401-14398	MAIN COOL SHEET	MAIN 放熱シート	(2)
17		401-11214	FAN MOTOR ASSY	ファンモータ組	(1)
18		KX-0000003-20	BUSH	ブッシュ	(1)
19		KX-0000002-60	SADDLE TYPE TIE MOUNT	サドルタイプ タイマウント	(1)
20		HX-0022200-OD	WIRE SADDLE	ワイヤーサドル	(1)
21		HX-0029200-0A	CONNECTING PART	束線パーツ	(1)
22	#05	HX-0033900-0M	SPACER	スペーサ	(6)
23		SL-4040881-SC	SCREW M4 L=8	座金付きなべ小ねじ M 4 L = 8	(8)
24		SL-4040881-SC	SCREW M4 L=8	座金付きなべ小ねじ M 4 L = 8	(4)
25		SL-4040881-SC	SCREW M4 L=8	座金付きなべ小ねじ M 4 L = 8	(2)
26		SL-4040881-SC	SCREW M4 L=8	座金付きなべ小ねじ M 4 L = 8	(2)
27		SL-4040881-SC	SCREW M4 L=8	座金付きなべ小ねじ M 4 L = 8	(2)
28		SL-4040881-SC	SCREW M4 L=8	座金付きなべ小ねじ M 4 L = 8	(2)
29		SL-4040881-SC	SCREW M4 L=8	座金付きなべ小ねじ M 4 L = 8	(1)
30	#05	SL-4040881-SC	SCREW M4 L=8	座金付きなべ小ねじ M 4 L = 8	(6)
31		SL-4040881-SC	SCREW M4 L=8	座金付きなべ小ねじ M 4 L = 8	(1)
32		SL-4042091-SC	SCREW M4X0.7 L=20	なべ小ねじセムス M 4 X 0. 7 L = 2 0	(2)
33		SL-4041281-SC	SCREW M4X0.7 L=12	なべ小ねじセムス M 4 X 0. 7 L = 1 2	(4)
34		M8002-430-000	STOPPER	ねじストッパー	(4)
35	#03	401-05475	FLT-CE PCB ASSY	FLT-CE 基板組	(1)
36	#01	401-43988	FRAME A	電装筐体 単相	(1)
37		SL-4040881-SC	SCREW M4 L=8	座金付きなべ小ねじ M 4 L = 8	(3)
38	#02	SL-4030881-SC	SCREW M3 L=8	座金付きなべ小ねじ M 3 L = 8	(1)
39	#04	CM-3001000-01	LABEL	危険電圧警告シール (31. 5)	(1)
40		CM-3004006-02	VOLTAGE CAUTION LABEL L=25	電圧注意シール L = 2 5	(1)
41	#02	CM-3001004-02	VOLTAGE DANGER LABEL 3 (SMALL)	電撃危険ラベル3 (小)	(1)
42	#03	CM-6001001-01	WEEE MARK LABEL S	WEEE マーク ラベル S	(1)
43	#03	401-16677	GOST SAFTY LABEL S	GOST 安全ラベル小	(1)
44		EA-9500B01-00	CABLE BAND	結束バンド	(1)
45		E8760-452-S00	TUBE	スミチューブ	(0.055)
46		WP-0852086-SC	WASHER M8	平座金	4
47		WS-0820002-KR	SPRING WASHER M8	ばね座金 8. 2 X 1 5. 4 X 2	4
48		NM-6080002-SC	NUT M8	六角ナット M 8 2種	4
49		HF-0013050-P0	FUSE 5A	ヒューズ 5 A	1
50		HF-0030002-00	FUSE 2A (220/240V)	即断ヒューズ	1
51		M3004-511-00A	VOLTAGE INDICATION CARD A	電源圧表示札 A	1
52		MTS-HJ100003	BOLT	モータ取付けボルト	4
53		401-44511	CORE SET UP MANUAL	コア取付けマニュアル	1
		NOTE(注記)	#01....FOR 1-PHASE 220~240V	単相 220~240 V 用	
			#02....FOR 3-PHASE 200~240V	三相 200~240 V 用	
			#03....FOR 1-PHASE CE 220~240V	単相 CE 220~240 V 用	
			#04....FOR 1-PHASE 220~240V,	単相 220~240 V,	
			1-PHASE CE 220~240V,	単相 CE 220~240 V,	
			1-PHASE 220~240V	単相 220~240 V 用	
			(FOR CHINA)	(中国向け)	
			#05....FOR 3-PHASE 200~240V,	三相 200~240 V,	
			1-PHASE CE 220~240V	単相 CE 220~240 V 用	

17. OPERATION PANEL COMPONENTS

操作パネル関係

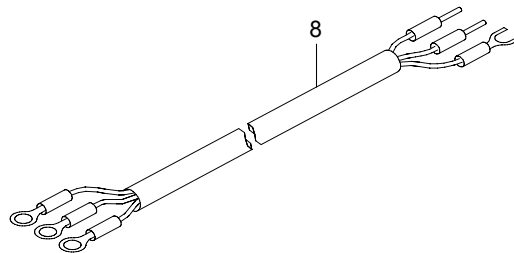
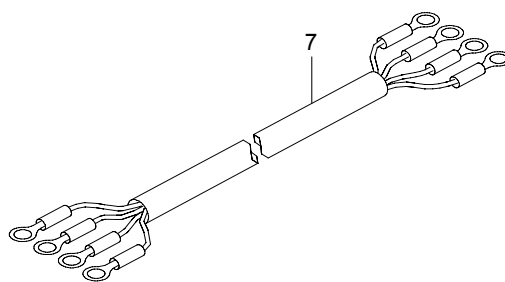
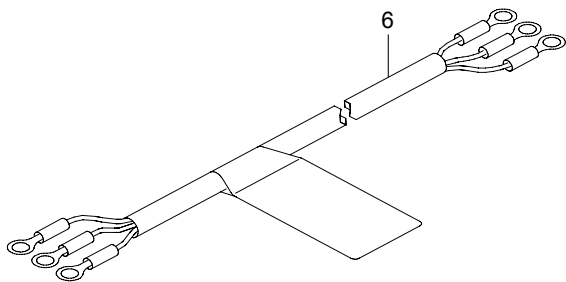
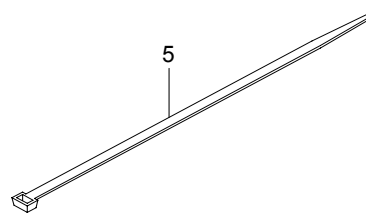
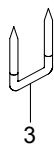
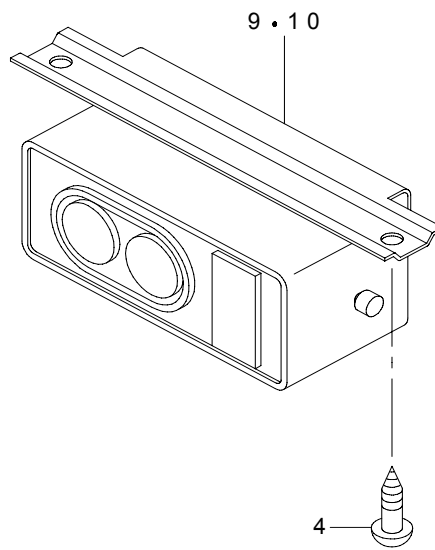
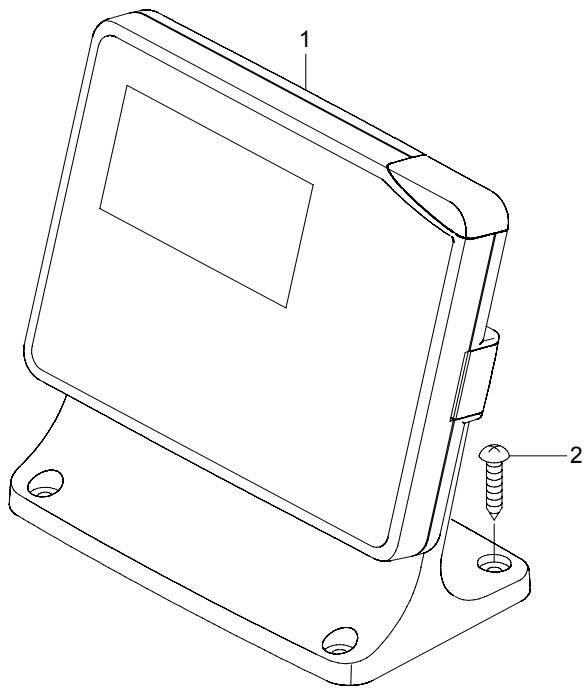

REF.NO	NOTE	PART NO	DESCRIPTION	品名	Qty
1		401-42272	OPERATION BOX ASSY	操作ボックス組	1
2		SK-3382001-SE	SCREW D=3.8 L=20	丸木ねじ D = 3. 8 L = 2 0	4
3		MAO-11532000	CORD STAPLE	コードステップル	2
4		SK-3512001-SE	WOOD SCREW D=5.1 L=20	丸木ねじ D = 5. 1 L = 2 0	2
5		EA-9500B02-00	CABLE BAND 150	結束バンド 150	2
6	#02	400-23371	SINGLE PHASE POWER CORD ASSY	単相用電源コード組	1
7	#03	M9017-580-0A0	POWER CABLE ASM.	電源ケーブル組	1
8	#01	400-05390	JE POWER CABLE ASM.	J E 電源ケーブル組	1
9	#02	401-13427	POWER SWITCH	電源スイッチ	1
10	#03	HA-0042500-00	SWITCH	スイッチ	1
		NOTE(注記)	#01....FOR 1-PHASE CE200 ~ 240V	単相 CE 200 ~ 240 V 用	
			#02....FOR 1-PHASE 200 ~ 240V	単相 200 ~ 240 V 用	
			#03....FOR 3-PHASE 200 ~ 240V	三相 200 ~ 240 V 用	

REF.NO	NOTE	PART NO	DESCRIPTION	品 名	Qty
1		401-37360	MAIN PCB ASSY	MA I N 基板組	1
2		401-42267	SDC PCB ASSY	S D C 基板組	1
3		401-42272	OPERATION BOX ASSY	操作ボックス組	1
4		400-12037	LKA-BR RELAY CABLE ASM	L K A - B R 中継ケーブル組	1
5	#01	401-41488	AC POWER CORD B ASM.	電装電源コード B 組	1
6	#02	401-41489	AC POWER CORD C ASM.	電装電源コード C 組	1
7	#01	M9017-580-0A0	POWER CABLE ASM.	電源ケーブル組	1
8	#02	400-05390	JE POWER CABLE ASM.	J E 電源ケーブル組	1
9	#03	400-23371	SINGLE PHASE POWER CORD ASSY	単相用電源コード組	1
10	#01	HA-0042500-00	SWITCH	スイッチ	1
11	#03	401-13427	POWER SWITCH	電源スイッチ	1
12	#03	401-41487	AC POWER CORD A ASM.	電装電源コード A 組	1
13		401-38137	IPM550W MOTOR	I P M 5 5 0 W モータ	1
14		401-11214	FAN MOTOR ASSY	ファンモータ組	1
15		400-05728	SOLENOID RELAY CABLE ASM.	ソレノイド中継ケーブル組	1
16		400-06912	SOLENOID FOR PICK UP ASM.	布寄せソレノイド組	1
17		401-42273	AT SOLENOID	A T ソレノイド	1
18		400-06495	SAFETY_SW_ASM.	安全スイッチ組	1
19		401-42747	TT SENSOR CABLE ASM.	糸切りセンサケーブル組	1
20		400-05732	PF SENSOR CABLE ASM.	押え上げセンサケーブル組	1
21		401-37370	INT PCB ASM.	I N T 基板組	1
22		401-39176	X FEED MOTOR	X 送りモータ	1
23		401-39177	Y FEED MOTOR	Y 送りモータ	1
24		401-39178	PRESSER LIFTING MOTOR	押え上げモータ	1
25		401-39179	THREAD CLAMP MOTOR	糸掴みモータ	1
26	#01	401-05465	FLT-T PCB ASSY	F L T - T 基板組	1
27	#02	401-05475	FLT-CE PCB ASSY	F L T - C E 基板組	1
28		401-14373	SDC-MAIN P1 CORD ASM.	S D C - M A I N コード P 1 組	1
29		401-14375	SDC-MAIN S CORD ASM.	S D C - M A I N コード S 組	1
30		HD-0022300-00	PHOTO SENSOR	フォトインタラプタ	1
31		HD-0005700-0A	PHOTO SENSOR	フォトセンサ	1
		NOTE(注記)	#01....3-PHASE 200~240V (FOR USE IN JAPAN AND JA)	三相200~240V (日本、アメリカ用)	
			#02....1-PHASE 200~240V (FOR CE)	単相200~240V (CE用)	
			#03....1-PHASE 200~240V (FOR GENERAL EXPORT AND CHINA)	単相200~240V (一般輸出、中国用)	

19. BR35 WIRING DIAGRAM

BR 35 電装配線図

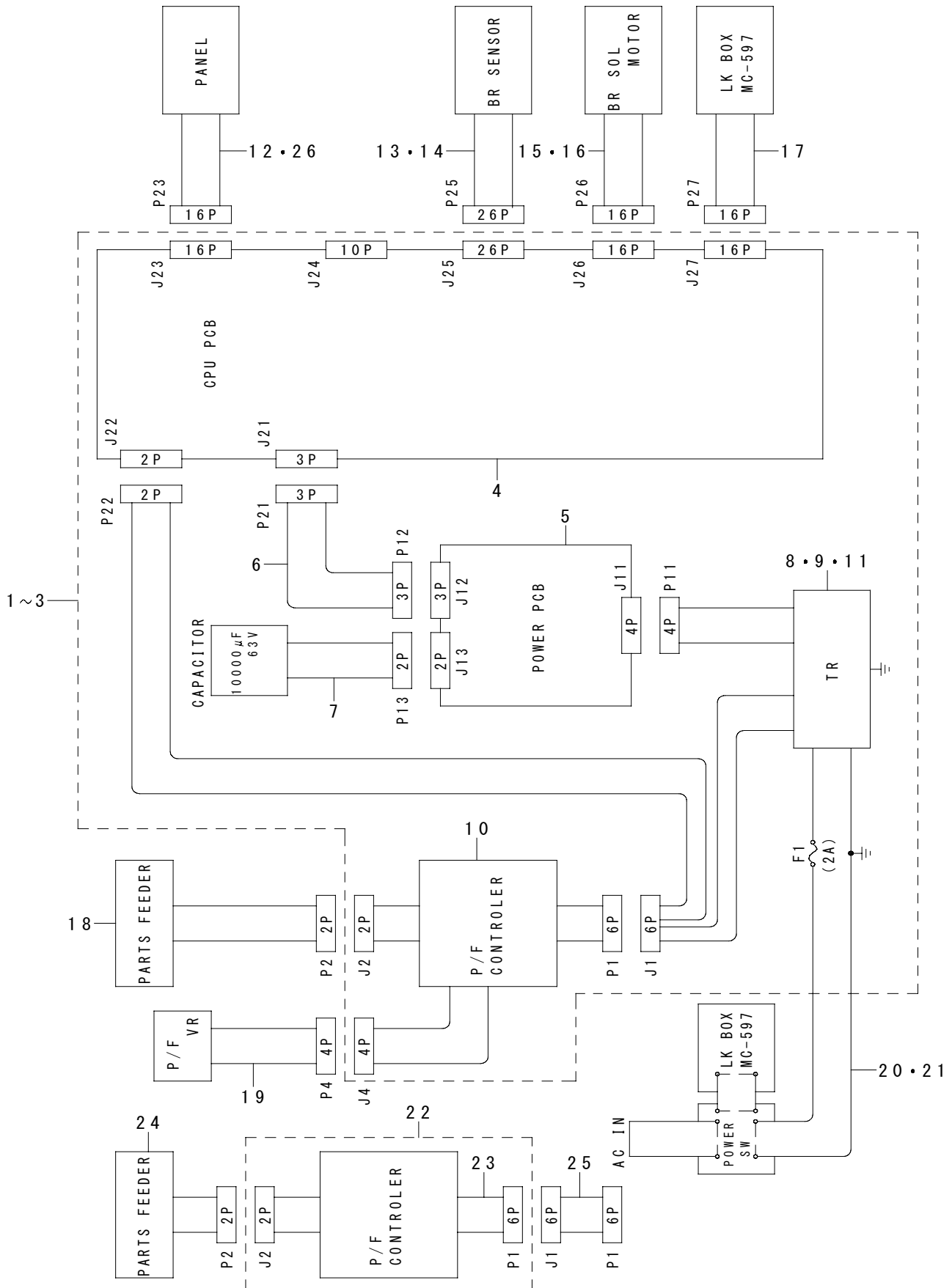

REF.NO	NOTE	PART NO	DESCRIPTION	品名	Qty
1	#01	400-14495	CONTROL BOX A ASM.	電装ボックス A 組	1
2	#02	400-14506	CONTROL BOX B ASM.	電装ボックス B 組	1
3	#03	400-14526	CONTROL BOX C ASM.	電装ボックス C 組	1
4		GBR-107510A0	CPU BOARD ASM.	CPU 基板組	(1)
5		GBR-107610A0	POWER BOARD	電源基板組	(1)
6		GBR-107720A0	CPU BOARD POWER CORD ASM.	CPU 基板電源コード組	(1)
7		GBR-107430A0	CONDENSER ASM.	コンデンサ組	(1)
8	#01	GBR-107480AA	TRANS A ASM.	トランス A 組	(1)
9	#02	GBR-107480AB	TRANS B ASM.	トランス B 組	(1)
10	#04	GBR-107740A0	P/F CONTROLLER ASM.	P / F コントローラ組	(1)
11	#03	GBR-107480AC	TRANS C ASM.	トランス C 組	(1)
12	#04	GBR-30784AA0	OPERATION PANEL WHOLE ASM. (A)	操作パネル総組 (A)	1
13	#03	GBR-108410BC	SENSOR CONNECTING CABLE ASM.	BR センサ C 総組	1
14	#04	GBR-108410B0	BR SENSOR ASM.	BR センサー総組	1
15	#03	GBR-108510AC	BR DRIVING SOURCE ASM.	BR 駆動源 C 総組	1
16	#04	GBR-108510A0	BR DRIVING SOURCE ASM.	BR 駆動源総組	1
17		400-12037	LKA-BR RELAY CABLE ASM.	LKA - BR 中継ケーブル組	1
18	#04	GBR-107910A0	PARTS FEEDER ALL ASM.	パーツフィーダー組	1
19	#04	GBR-107870A0	VOLUME ASM.	ボリューム組	1
20	#05	GBR-107440A0	AC INPUT POWER CABLE CORD ASM.	AC 入力電源コード組 B	1
21	#01	GBR-107450A0	AC INPUT POWER CABLE CORD ASM.	AC 入力電源コード組	1
22	#03	GBR-108010A0	P/F CONTROLLER ASM.	P / F コントローラ総組	1
23	#03	GBR-108210A0	P/F POWER CORD ASM.	P / F 電源コード組	(1)
24	#03	GBR-107910AC	PARTS FEEDR ALL C ASM.	パーツフィーダ C 組	1
25	#03	GBR-250810A0	P/F CONTROLLER RELAY CABLE ASM.	P / F コントローラ中継ケーブル組	1
26	#03	GBR-250610AC	OPERATION PANEL WHOLE ASM. C	操作パネル総組 (C)	1
		NOTE(注記)	#01....FOR 100 ~ 200V	100~200V 用	
			#02....FOR 220 ~ 240V	220~240V 用	
			#03....FOR CE	CE 用	
			#04....EXCEPT CE	CE を除く	
			#05....FOR 220 ~ 240V,CE	220~240V, CE 用	

20. ACCESSORIE PARTS COMPONENTS

付属品関係

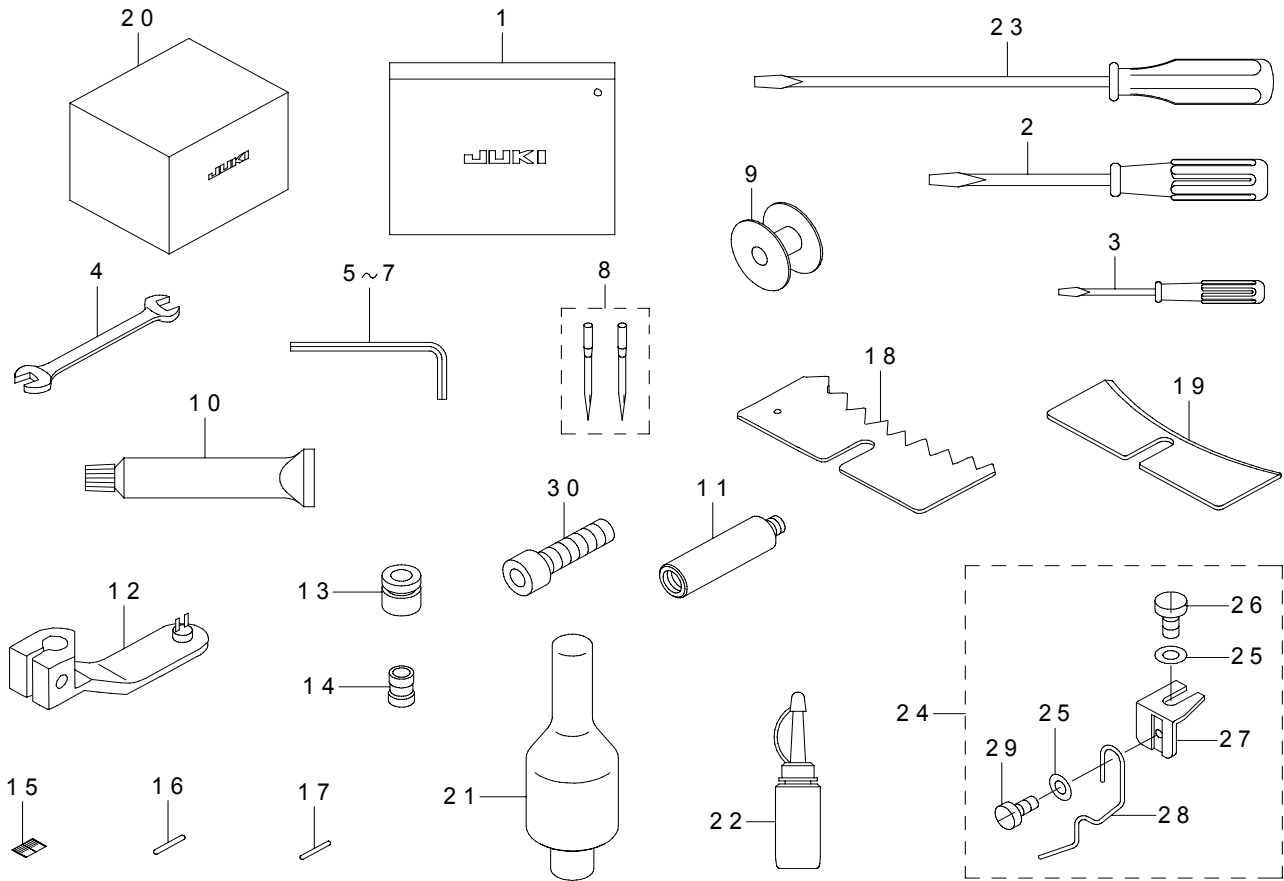

REF.NO	NOTE	PART NO	DESCRIPTION	品名	Qty
1		229-32800	ACCESSORIE BAG	付属品バッグ	1
2		229-33105	SCREW DRIVER MIDDLE	ドライバー (中)	1
3		229-33204	SCREW DRIVER SMALL	ドライバー (小)	1
4		B9113-012-000	WRENCH (9X10)	両口スパナ (小)	1
5		B9140-372-000	HEXAGONAL WRENCH SMALL	六角棒スパナ (小)	1
6		B9141-372-000	HEXAGONAL WRENCH LARGE	六角棒スパナ (大)	1
7		GCT-02906000	HEXAGONAL SPANNER	六角棒スパナ	1
8	☆	MDP-170B1402	NEEDLE DPX17#14-2	DPX 17# 14-2	1
9		138-12102	BOBBIN	ボビン	1
10	☆	400-13640	JUKI_GREASE_B_TUBE	ジューキグリース B	1
11		400-36110	GREASE_JOINT_B	グリス継手 B	1
12		165-58009	BUTTON CARRIER B	ボタンキャリア B	1
13		165-58108	RING SMALL	芯出しリング小	1
14	☆	182-00501	WORK ATTACHMENT (SMALL)	ワークアタッチメント (小)	3
15		182-04701	SCALE	メモリ (左)	4
16		GBR-01155000	SET PIN A	セットピン A	6
17		GBR-01156000	SET PIN B	セットピン B	4
18		GBR-01423000	SELECTOR PLATE MEDIUM	選別板 (中)	1
19		GBR-01437000	AUXILIARY PLATE	選別補助板	1
20		400-48664	HEAD_COVER	頭部カバー	1
21		141-01208	HEAD SUPPORT BAR	頭部支え棒	1
22		B9121-220-0A0	OILER (CONTAINING NO.2 OIL)	油差し NO 2入り	1
23		229-33006	SCREW DRIVER LARGE	ドライバー (大)	1
24		141-46757	BUTTON RISING BAR ASM.	ボタン浮かし棒組	1
25		WP-0370316-SD	WASHER 3.7X8X0.3	平座金 3.7 X 8 X 0.3	(2)
26		SS-9090813-TP	SCREW 9/64-40 L=8	六角ボルト 9/64-40 L=8	(1)
27		141-46807	INSTALLING BASE	浮かし棒取付板	(1)
28		141-46708	BUTTON RISING BAR	ボタン浮かし棒	(1)
29		SS-6080340-SP	SCREW 1/8-44 L=2.9	平ねじ 1/8-44 L=2.9	(1)
30		SM-6083002-TN	SCREW M8 L=30	六角穴ボルト M8 L=30	1

NUMERICAL INDEX OF PARTS

索引

PART NO 品番	PAGE 頁	REF NO	PART NO 品番	PAGE 頁	REF NO	PART NO 品番	PAGE 頁	REF NO	PART NO 品番	PAGE 頁	REF NO
B1114-581-000	1	3	GBR-01437000	37	19	GBR-10854000	28	17	HX-0022200-0D	30	20
B1426-771-000	14	10	GBR-01441000	20	4	GBR-108550A0	12	50	HX-0022800-0A	24	7
B1853-512-00E	6	48	GBR-01601000-A	8	42	GBR-108550A0	28	18	HX-0022800-0A	26	6
B2102-205-00A	2	8	GBR-01606000	8	39	GBR-108560A0	18	47	HX-0029200-0A	30	21
B2107-816-000	18	56	GBR-01607000	8	40	GBR-108560A0	28	20	HX-0033900-0B	22	52
B2107-816-000-A	16	8	GBR-107240AC	26	2	GBR-108580AC	28	13	HX-0033900-0F	22	50
B2414-280-0A0	6	37	GBR-107240A0	24	3	GBR-108580A0	28	12	HX-0033900-0M	30	22
B2415-280-0A0	6	36	GBR-10726000	26	32	GBR-108590A0	14	27	HX-0033900-00	22	44
B2416-280-000	6	35	GBR-10728000	26	46	GBR-108590A0	28	19			
B2417-280-000	6	38	GBR-107430A0	24	19	GBR-11109000	12	54	KX-0000002-60	30	19
B2418-280-000	6	34	GBR-107430A0	26	16	GBR-11110000	12	51	KX-0000003-20	30	18
B2421-280-0A0	6	33	GBR-107430A0	36	7	GBR-11111000	12	55			
B2423-280-00A	6	23	GBR-107440A0	24	24	GBR-11112000	12	24	MAO-11532000	22	55
B2423-280-00B	6	24	GBR-107440A0	26	20	GBR-11113000	12	66	MAO-11532000	26	58
B2423-280-00C	6	25	GBR-107440A0	36	20	GBR-11114000	12	56	MAO-11532000	32	3
B2423-280-00D	6	26	GBR-107450A0	24	23	GBR-11115000	12	62	MAO-14506000	24	48
B2423-280-00E	6	27	GBR-107450A0	36	21	GBR-207340A0	24	40	MAO-14506000	26	44
B2424-280-000	6	32	GBR-107460AA	24	9	GBR-207340A0	26	26	MAZ-088270A0	8	38
B2548-372-RA0	8	44	GBR-107460AB	24	8	GBR-25003000	8	59	MAZ-08828000	8	20
B2549-372-R00	8	35	GBR-107460AC	26	7	GBR-25004000	8	57	MAZ-08829000	8	14
B2553-372-000	8	32	GBR-10747000	24	18	GBR-25005000	10	41	MAZ-15502000	4	4
B2560-372-000	8	33	GBR-10747000	26	15	GBR-25006000	22	58	MAZ-15514000	8	3
B2561-372-000	8	26	GBR-107480AA	24	10	GBR-25010000	22	71	MAZ-15515000	8	27
B2619-372-000	6	47	GBR-107480AA	36	8	GBR-250610AC	36	26	MAZ-15601000	6	31
B3052-816-000	22	45	GBR-107480AB	24	11	GBR-250810A0	26	57	MAZ-15602000	4	5
B5541-205-0A0	1	2	GBR-107480AB	36	9	GBR-250810A0	36	25	MAZ-15801000	6	30
B5542-205-000	22	63	GBR-107480AC	26	8	GBR-30784AA0	24	41	MAZ-16522000	8	10
B8101-210-AAB	22	5	GBR-107480AC	36	11	GBR-30784AA0	36	12	MAZ-166070A0	8	15
B8105-210-AAA	22	6	GBR-107510A0	24	28	GBR-30788000	24	56	MAZ-166070B0	8	12
B8150-210-000	22	26	GBR-107510A0	26	35	GBR-30788000	26	56	MAZ-166080A0	8	18
B8153-771-000	22	15	GBR-107510A0	36	4	GBR-308650A0	22	65	MAZ-166080B0	8	17
B8202-205-000	22	41	GBR-107610A0	24	4	GCT-02906000	37	7	MDP-170B1400	6	45
B9113-012-000	37	4	GBR-107610A0	26	3	GPF-060600A0	22	18	MDP-170B1402	37	8
B9121-012-000	22	54	GBR-107610A0	36	5	GPF-06080000	22	17	MTS-HJ100003	30	52
B9121-220-0A0	37	22	GBR-107720A0	24	35				M3004-511-00A	30	51
B9140-372-000	37	5	GBR-107720A0	26	31	HA-0019100-00	24	51	M8002-430-000	30	34
B9141-372-000	37	6	GBR-107720A0	36	6	HA-0019100-00	26	48	M9017-580-0A0	32	7
			GBR-107740A0	24	36	HA-0019100-1B	24	43	M9017-580-0A0	34	7
CM-2001000-01	26	23	GBR-107740A0	36	10	HA-0019100-1B	26	49	M9640-510-00A	22	67
CM-3001000-01	30	39	GBR-10775000	24	37	HA-0019100-1C	24	49			
CM-3001001-01	24	59	GBR-10782000	24	53	HA-0019100-1C	26	45	NM-6040001-SC	12	22
CM-3001004-02	30	41	GBR-10782000	26	53	HA-0029000-00	24	46	NM-6040001-SC	12	45
CM-3002002-B1	22	47	GBR-107850AC	26	40	HA-0029000-00	26	42	NM-6040001-SC	12	47
CM-3004006-02	30	40	GBR-107850A0	24	42	HA-0029800-00	24	6	NM-6040001-SC	14	5
CM-6001001-01	30	42	GBR-10786000	24	50	HA-0029800-00	26	5	NM-6040001-SC	16	12
			GBR-10786000	26	47	HA-0042500-00	32	10	NM-6040001-SC	16	46
D2431-555-B00	22	61	GBR-107870A0	24	54	HA-0042500-00	34	10	NM-6040001-SC	16	66
D2527-232-D00	4	9	GBR-107870A0	36	19	HD-0003600-00	14	28	NM-6040001-SC	18	24
D2548-232-D00	8	30	GBR-107910AC	36	24	HD-0005700-0A	34	31	NM-6040001-SC	28	10
D2572-M1Y-C0F	8	45	GBR-107910A0	20	31	HD-0022300-00	34	30	NM-6040001-SF	24	26
D3130-M1Y-C00	8	21	GBR-107910A0	36	18	HF-0013050-P0	30	49	NM-6040001-SF	26	22
D6042-555-B00	20	37	GBR-10791000	20	35	HF-0030002-00	30	50	NM-6040003-SC	2	12
D8113-555-B00	22	16	GBR-108010A0	26	38	HF-0051110-0B	24	14	NM-6050001-SC	10	23
D8204-555-D00	22	33	GBR-108010A0	36	22	HF-0051110-0B	26	12	NM-6050001-SC	12	14
			GBR-108210A0	36	23	HF-0051110-00	24	13	NM-6050001-SC	14	7
EA-9500B01-00	24	55	GBR-108410BC	36	13	HF-0051110-00	26	10	NM-6060001-SC	20	5
EA-9500B01-00	26	54	GBR-108410B0	36	14	HF-0084020-P0	24	29	NM-6060001-SC	22	40
EA-9500B01-00	30	44	GBR-108420A0	28	5	HF-0084020-P0	26	36	NM-6060001-SC	28	34
EA-9500B02-00	32	5	GBR-108420A0	28	29	HF-0084063-P0	24	30	NM-6080001-SC	20	21
E5006-171-000	12	57	GBR-108430A0	16	20	HF-0084063-P0	26	37	NM-6080001-SC	20	27
E8760-452-S00	30	45	GBR-108430A0	28	6	HG-0029100-0A	24	44	NM-6080002-SC	30	48
E9613-601-000	24	5	GBR-108440A0	16	72	HG-0029100-0A	26	50	NM-6080721-SE	22	25
E9613-601-000	24	15	GBR-108440A0	28	7	HG-0029100-00	24	45	NM-6120003-SE	22	27
E9613-601-000	26	4	GBR-108450A0	18	66	HG-0029100-00	26	41	NS-6080210-SP	8	41
E9613-601-000	26	11	GBR-108450A0	28	9	HK-0044400-20	20	36	NS-6090310-SP	8	43
			GBR-108460AC	28	4	HK-0044900-20	20	32	NS-6110310-SP	2	23
GBR-01120000	14	1	GBR-108460A0	28	3	HL-0087301-40	24	39	NS-6110360-SP	12	61
GBR-01155000	37	16	GBR-108470A0	28	8	HL-0087301-43	26	25	NS-6110360-SP	12	65
GBR-01156000	37	17	GBR-108510AC	36	15	HX-0009800-00	24	25	NS-6120310-SP	2	19
GBR-01168000	14	17	GBR-108510A0	36	16	HX-0009800-00	26	21	NS-6150310-SP	8	31
GBR-01175000	12	46	GBR-10852000	10	6	HX-0011400-0A	24	47	NS-6150430-SP	28	23
GBR-014220A0	20	26	GBR-10852000	28	15	HX-0011400-0A	26	43			
GBR-01423000	37	18	GBR-10853000	16	50	HX-0012300-0C	2	3	RC-2500001-KP	14	2
GBR-01426000	20	2	GBR-10853000	28	16	HX-0015000-0B	24	21	RE-0200000-K0	10	5
GBR-01428000	20	14	GBR-10854000	16	56	HX-0015000-0B	26	18	RE-0200000-K0	16	69

NUMERICAL INDEX OF PARTS

索引

PART NO 品番	PAGE 頁	REF NO	PART NO 品番	PAGE 頁	REF NO	PART NO 品番	PAGE 頁	REF NO	PART NO 品番	PAGE 頁	REF NO
RE-0250000-K0	16	42	SM-0861201-SA	18	67	SM-8050602-TP	12	2	WP-0852086-SC	30	46
RE-0300000-K0	6	16	SM-1031401-SC	12	63	SM-8050602-TP	14	8	WP-0871602-SE	22	23
RE-0700000-K0	8	8	SM-1040601-SC	18	70	SM-8050602-TP	14	26	WP-0871602-SE	22	28
RE-1200000-K0	16	19	SM-1040650-TP	6	46	SM-8050602-TP	18	44	WS-0310002-KN	12	39
			SM-1041201-SC	18	69	SM-8050612-TP	10	42	WS-0310002-KN	18	58
SB-1100004-00	18	42	SM-4030601-SN	20	25	SM-8050612-TP	14	12	WS-0410002-KN	8	49
SB-1150004-00	10	15	SM-4040801-SF	18	5	SM-8050812-TP	14	16	WS-0410002-KN	10	40
SD-0500091-TP	6	40	SM-4040801-SN	20	8	SM-8050842-TP	14	24	WS-0410002-KN	12	28
SD-0500404-SP	8	36	SM-4040801-SN	20	12	SM-8050842-TP	14	31	WS-0410002-KN	12	32
SD-0550303-TP	8	34	SM-4041001-SC	24	12	SM-8086012-TP	20	10	WS-0410002-KN	12	36
SD-0600181-TP	2	16	SM-4041001-SC	26	9	SM-9040600-SP	28	11	WS-0410002-KN	12	48
SD-0600341-TP	10	7	SM-4051001-SN	20	15	SM-9042510-SC	28	2	WS-0410002-KN	12	60
SD-0600401-TP	10	11	SM-4860501-SC	18	8	SM-9061203-SE	22	19	WS-0410002-KN	16	16
SD-0600651-TP	12	58	SM-5040601-SC	24	38	SM-9082023-SE	22	22	WS-0410002-KN	16	33
SD-0601021-SP	10	13	SM-5040601-SC	26	33	SM-9086523-SE	22	31	WS-0410002-KN	16	45
SD-0640261-SP	2	17	SM-5040855-SN	4	13	SS-1060210-TP	6	39	WS-0410002-KN	16	48
SD-0640391-TP	8	25	SM-5040855-SN	22	70	SS-4110815-SP	20	3	WS-0410002-KN	16	57
SD-0700332-SP	28	24	SM-6030500-SN	6	43	SS-6080340-SP	37	29	WS-0410002-KN	16	58
SD-0791276-TP	6	49	SM-6030602-TP	8	53	SS-6110430-TP	6	42	WS-0410002-KN	16	60
SK-3311601-SE	22	34	SM-6030802-TP	18	19	SS-6111052-TP	12	25	WS-0410002-KN	16	64
SK-3311601-SE	22	42	SM-6030802-TP	18	57	SS-7060310-SP	2	22	WS-0410002-KN	16	67
SK-3311601-SE	22	64	SM-6031202-TP	12	8	SS-7090410-SP	6	22	WS-0410002-KN	18	32
SK-3382001-SE	22	68	SM-6031402-TP	12	38	SS-7090410-SP	8	13	WS-0410002-KN	18	35
SK-3382001-SE	32	2	SM-6040650-TP	2	1	SS-7090410-SP	8	19	WS-0410002-KN	22	51
SK-3452501-SE	24	34	SM-6040802-TN	24	58	SS-7091480-SP	8	37	WS-0410002-KS	2	13
SK-3452501-SE	26	30	SM-6040802-TN	26	51	SS-7110740-TP	6	41	WS-0451040-KP	2	6
SK-3483201-SE	22	35	SM-6040802-TP	10	39	SS-7111120-TP	2	9	WS-0510002-KN	10	19
SK-3512001-SE	32	4	SM-6040802-TP	16	59	SS-9090813-TP	37	26	WS-0510002-KN	28	32
SL-4030681-SC	24	16	SM-6040802-TP	16	63	SS-9091010-SP	8	5	WS-0510002-KP	8	61
SL-4030681-SC	24	32	SM-6040802-TR	16	13	SS-9110460-CP	8	22	WS-0510002-KP	8	62
SL-4030681-SC	24	52	SM-6040802-TR	18	34	SS-9110543-CP	4	6	WS-0510002-KS	12	13
SL-4030681-SC	26	13	SM-6041002-TP	12	31	SS-9151120-CP	8	54	WS-0610002-KN	10	28
SL-4030681-SC	26	28	SM-6041002-TP	16	9	SS-9621413-SP	8	23	WS-0610002-KN	14	34
SL-4030681-SC	26	52	SM-6041002-TP	16	15				WS-0610002-KN	16	71
SL-4030881-SC	24	22	SM-6041002-TP	16	23	TA-1250705-R0	2	2	WS-0610002-KN	20	7
SL-4030881-SC	26	19	SM-6041002-TP	16	47				WS-0621210-KR	22	21
SL-4030881-SC	28	14	SM-6041002-TP	18	55	WP-0280500-SC	18	9	WS-0820002-KR	30	47
SL-4030881-SC	28	30	SM-6041202-TP	8	56	WP-0320500-SC	18	59	WS-0861410-KR	22	24
SL-4030881-SC	30	38	SM-6041202-TP	12	27	WP-0320500-SC	20	24	WS-0861410-KR	22	29
SL-4031081-SC	14	29	SM-6041202-TP	16	26	WP-0370316-SD	37	25	WZ-0640200-KP	2	18
SL-4040881-SC	30	23	SM-6041202-TP	16	32	WP-0430800-SC	10	16			
SL-4040881-SC	30	24	SM-6041202-TP	16	36	WP-0430800-SC	12	29	100-04109	26	24
SL-4040881-SC	30	25	SM-6041202-TP	16	62	WP-0430800-SC	12	33	111-55108	22	62
SL-4040881-SC	30	26	SM-6041202-TP	18	38	WP-0430800-SC	12	37	111-55207	22	32
SL-4040881-SC	30	27	SM-6041402-TP	12	35	WP-0430800-SC	12	49	111-58300	22	7
SL-4040881-SC	30	28	SM-6042002-TP	12	23	WP-0430800-SC	16	17	111-58409	22	8
SL-4040881-SC	30	29	SM-6042502-TP	12	41	WP-0430800-SC	16	28	111-58516	22	11
SL-4040881-SC	30	30	SM-6050802-TP	10	37	WP-0430800-SC	16	29	111-58607	22	9
SL-4040881-SC	30	31	SM-6051202-TP	8	60	WP-0430800-SC	16	49	111-59001	22	14
SL-4040881-SC	30	37	SM-6051202-TP	18	39	WP-0430800-SC	16	61	111-59506	22	30
SL-4040891-SC	24	20	SM-6051202-TP	18	54	WP-0430800-SC	16	65	131-60304	22	56
SL-4040891-SC	24	27	SM-6051402-TP	12	10	WP-0430800-SC	18	36	135-40901	8	29
SL-4040891-SC	24	31	SM-6051602-TP	8	50	WP-0430800-SC	20	13	138-11906	4	12
SL-4040891-SC	24	33	SM-6051602-TP	18	41	WP-0430800-SC	30	4	138-12003	4	11
SL-4040891-SC	26	17	SM-6051602-TP	28	31	WP-0430801-SC	12	59	138-12102	37	9
SL-4040891-SC	26	27	SM-6052002-TP	18	31	WP-0450801-SD	2	5	138-17754	22	13
SL-4040891-SC	26	29	SM-6052502-TP	10	18	WP-0450801-SD	20	29	138-64509	2	14
SL-4040891-SC	26	34	SM-6061202-TP	8	46	WP-0450846-SP	6	28	141-01208	37	21
SL-4041091-SC	2	4	SM-6061602-TP	16	70	WP-0501016-SD	4	7	141-03352	6	18
SL-4041091-SC	22	66	SM-6061802-TP	6	50	WP-0501016-SD	8	24	141-18152	22	3
SL-4041091-SC	24	57	SM-6062002-TP	14	33	WP-0531000-SC	20	30	141-18251	22	4
SL-4041091-SC	26	55	SM-6062502-TP	22	59	WP-0531000-SC	28	33	141-41402	8	7
SL-4041281-SC	30	33	SM-6063002-TP	10	27	WP-0531000-SD	8	48	141-45106	4	1
SL-4041291-SC	24	17	SM-6066552-TP	22	37	WP-0611626-SP	22	60	141-46104	8	6
SL-4041291-SC	26	14	SM-6083002-TN	37	30	WP-0612056-SD	22	38	141-46203	8	4
SL-4042091-SC	30	32	SM-8030402-TP	16	30	WP-0612516-SD	8	47	141-46302	8	9
SL-9082091-SE	22	12	SM-8040402-TP	14	30	WP-0612516-SD	8	55	141-46708	37	28
SM-0040601-SA	22	53	SM-8040402-TP	18	52	WP-0621036-SP	22	72	141-46757	37	24
SM-0040601-SC	16	2	SM-8040602-TP	10	32	WP-0641600-SC	14	19	141-46807	37	27
SM-0040601-SC	18	3	SM-8040602-TP	12	18	WP-0641600-SC	16	53	141-46906	4	10
SM-0040601-SC	20	17	SM-8040602-TP	14	22	WP-0641600-SC	20	6	141-47607	2	15
SM-0040601-SC	20	34	SM-8042502-TP	16	11	WP-0651646-SC	22	39	141-47755	2	11
SM-0040601-SC	28	1	SM-8050502-TP	18	13	WP-0671016-SE	22	20	141-47805	2	21
SM-0861201-SA	16	21	SM-80506A2-TP	6	9	WP-0820516-SP	6	6	141-48407	4	3
SM-0861201-SA	16	73	SM-8050602-TP	10	9	WP-0841601-SC	20	28	141-90052	8	1

NUMERICAL INDEX OF PARTS

索引

PART NO 品番	PAGE 頁	REF NO	PART NO 品番	PAGE 頁	REF NO	PART NO 品番	PAGE 頁	REF NO	PART NO 品番	PAGE 頁	REF NO
141-90151	8	2	165-70707	18	33	182-17950	14	3	401-14373	34	28
141-90300	8	28	165-70905	18	37	182-18008	18	71	401-14375	34	29
141-90458	8	11	165-71408	18	49	182-18206	10	3	401-14398	30	16
141-90557	8	16	165-71606	18	72	182-18800	12	20	401-15874	30	7
141-91951	22	2	165-71804	18	45	182-18909	16	6	401-15876	30	9
165-50105	10	38	165-71903	18	15	182-19204	16	37	401-15877	30	10
165-50204	12	42	165-72000	16	78	182-19501	18	20	401-15878	30	11
165-50402	12	40	165-72406	16	24	182-19600	18	40	401-15879	30	12
165-50808	12	3	165-72505	16	41	182-19709	10	2	401-16677	30	43
165-51806	12	30	165-72703	18	28	182-19808	10	12	401-37360	30	13
165-51905	12	16	165-72703	18	62	182-19907	28	25	401-37360	34	1
165-52309	12	21	165-72703	18	65	182-22604	22	43	401-37370	34	21
165-52507	10	1	165-73008	18	14	182-27553	14	9	401-38137	34	13
165-52606	10	10	165-73305	16	44	182-27603	8	51	401-39176	34	22
165-53208	10	21	165-73701	18	2	182-27702	10	26	401-39177	34	23
165-53208	16	5	165-73909	18	46	182-27850	10	8	401-39178	34	24
165-53307	10	22	165-74006	16	18	182-27959	12	5	401-39179	34	25
165-54008	10	20	165-74105	16	3				401-41487	34	12
165-54008	16	38	165-74204	16	52	229-28808	4	8	401-41488	34	5
165-54503	10	30	165-77009	20	1	229-32800	37	1	401-41489	34	6
165-56300	12	44	165-77207	20	16	229-33006	37	23	401-42267	30	14
165-56409	12	43	165-77207	20	33	229-33105	37	2	401-42267	34	2
165-56508	12	52	165-77306	20	20	229-33204	37	3	401-42272	32	1
165-56607	12	34	165-77405	20	22	260-37903	22	57	401-42272	34	3
165-56706	10	14	165-77504	20	11	262-26506	12	64	401-42273	34	17
165-56805	10	25	165-79203	20	19				401-42663	30	1
165-57209	10	4	165-82504	28	27	400-05390	32	8	401-42664	30	2
165-57209	16	68	165-82603	28	28	400-05390	34	8	401-42665	30	3
165-57308	12	15	165-82702	28	35	400-05728	34	15	401-42691	6	2
165-57407	12	4	165-83403	28	26	400-05732	34	20	401-42697	6	12
165-57506	10	29	165-86505	22	49	400-06475	22	69	401-42701	6	11
165-57605	10	34	170-07402	22	10	400-06495	34	18	401-42723	6	20
165-57902	12	9	182-00303	18	29	400-06525	6	44	401-42724	6	21
165-58009	37	12	182-00352	18	27	400-06912	34	16	401-42725	6	29
165-58108	37	13	182-00501	12	19	400-06935	4	2	401-42747	34	19
165-58801	12	17	182-00501	37	14	400-09859	2	20	401-42785	6	1
165-59304	10	31	182-00709	8	52	400-10424	6	3	401-42786	6	10
165-59601	10	35	182-00907	18	64	400-10425	6	4	401-42787	6	13
165-60104	14	14	182-00956	18	63	400-10426	6	5	401-42790	6	14
165-60203	14	32	182-01103	18	53	400-11949	6	17	401-42807	6	15
165-60302	14	21	182-01608	16	27	400-12037	28	21	401-43988	30	36
165-61607	14	15	182-01905	18	6	400-12037	34	4	401-43989	30	5
165-61904	14	25	182-01962	18	1	400-12037	36	17	401-43990	30	8
165-62001	14	18	182-02002	18	7	400-13452	1	1	401-44511	30	53
165-62001	18	43	182-02101	16	76	400-13640	37	10	401-48338	22	1
165-62100	14	23	182-02150	16	74	400-14216	22	36			
165-62308	14	20	182-02200	16	77	400-14217	20	18			
165-62803	14	4	182-02408	20	23	400-14219	28	22			
165-62902	14	6	182-03307	18	4	400-14220	22	48			
165-65301	16	79	182-04107	16	34	400-14221	22	46			
165-65400	16	54	182-04206	18	16	400-14495	24	2			
165-65509	16	55	182-04503	18	25	400-14495	36	1			
165-65707	16	7	182-04602	20	9	400-14506	24	1			
165-65905	16	22	182-04701	37	15	400-14506	36	2			
165-66002	16	4	182-04909	16	75	400-14526	26	1			
165-66408	16	25	182-05401	12	26	400-14526	36	3			
165-66507	16	1	182-05708	12	12	400-16644	26	39			
165-66606	16	10	182-05906	12	6	400-18334	2	7			
165-67000	16	14	182-06003	12	1	400-18335	2	10			
165-67166	16	31	182-06201	12	53	400-23371	32	6			
165-67802	16	40	182-06409	12	7	400-23371	34	9			
165-67901	16	43	182-06607	12	11	400-36110	37	11			
165-68206	16	51	182-06706	10	24	400-48664	37	20			
165-68404	18	30	182-06904	10	36	401-05465	30	15			
165-68602	18	61	182-07209	14	11	401-05465	34	26			
165-68651	18	60	182-07506	14	13	401-05475	30	35			
165-68909	18	26	182-07902	10	17	401-05475	34	27			
165-69204	18	68	182-09007	8	58	401-10841	6	7			
165-69501	18	18	182-09502	16	35	401-10842	6	8			
165-69600	18	17	182-12902	18	50	401-10846	6	19			
165-70103	18	21	182-13405	18	11	401-11214	30	17			
165-70202	18	22	182-13454	18	10	401-11214	34	14			
165-70301	18	23	182-13504	18	12	401-13427	32	9			
165-70509	18	48	182-17505	16	39	401-13427	34	11			
165-70608	18	51	182-17752	10	33	401-14136	30	6			