

ENGLISH

**LH-4128, 4128-7
LH-4168-7, 4188-7
INSTRUCTION MANUAL**

CONTENTS

1. SPECIFICATIONS.....	1
2. NAME OF EACH COMPONENT	2
3. INSTALLATION.....	3
3-1. Installing the bottom cover.....	3
3-2. Opening and closing of the control box (SC-910).....	4
3-3. Adjusting the height of the knee lifter	5
3-4. Installation of thread stand.....	5
3-5. Caution when installing the panel	5
3-6. Connecting the cord.....	6
3-7. Managing the cord.....	8
3-8. Adjusting the knee lifter detection seat (asm.).....	10
4. PREPARATION OF THE SEWING MACHINE	11
4-1. Lubrication	11
4-2. Cleaning the filter	12
4-3. Adjusting the amount of oil in the hook	13
4-4. Attaching the needles	13
4-5. How to take out the bobbin case	14
4-6. Inserting a bobbin in a bobbin case	14
4-7. Threading the machine head.....	15
4-8. Thread tension.....	16
4-9. Thread take-up spring.....	16
4-10. Adjusting the stitch length	17
4-11. Winding the bobbin thread	18
4-12. Adjusting the needle stop position.....	19
4-13. Pedal pressure and pedal stroke	20
4-14. Adjustment of the pedal.....	20
5. OPERATION OF THE SEWING MACHINE.....	21
5-1. Pedal operation.....	21
5-2. Hand lifter.....	22
5-3. Adjusting the pressure of the presser foot.....	22
5-4. Thread tension release changeover when using the knee lifter	23
5-5. Separately driven needle changeover switch (for LH-4168-7 and 4188-7).....	24
5-6. One-touch reverse feed switch lever (for touch-back)	25
6. MAINTENANCE	25
6-1. Changing procedure to bottom feed and the adjustment (LH-4128 without thread trimmer only).....	25
6-2. Changing procedure to needle feed (for LH-4128 only)	27
6-3. Adjusting the inner hook guide.....	28
6-4. Needle-to-hook relation	29
6-5. Adjusting the height and the inclination of the feed dog	32
6-6. Adjusting the presser foot.....	32
6-7. Move (adjustment) of the hook shaft saddle when replacing the gauge	33
6-8. Adjusting the thread presser spring.....	33
6-9. Adjusting the position of the moving knife.....	34
6-10. Replacing the bobbin thread slack preventer spring (for LH-4168-7 and 4188-7)	35
6-11. Adjusting the hook needle guard	35
6-12. Stop of the needle bars and angle of corners for corners stitching (for LH-4168-7 and 4188-7)	36
6-13. Caution when installing the gauge to the bed slide.....	36
6-14. Position of the wiper	37
6-15. Replenishing grease to the specified places (for LH-4168-7 and 4188-7).....	37
6-16. Cleaning the inside of the needle bar bushing.....	39
7. STITCH-TO-ANGLE TABLE BY GAUGE (PITCH AND mm CONVERSION TABLE) ...	40
8. GAUGE SETS	41
9. TROUBLES AND CORRECTIVE MEASURES	46

1. SPECIFICATIONS

Model name	LH-4128	LH-4128-7 (with automatic thread trimmer)	LH-4168-7 (with automatic thread trimmer incorporating corner stitching)	LH-4188-7 (with automatic thread trimmer incorporating corner stitching)
Application	For light-, medium- and heavy-weight materials			For medium- and heavy-weight materials
Specification type *2	S, F, G	S, G		G
Hook	Standard hook			Large hook
Thread trimmer	Not provided	Provided		
Separately driven needle bar mechanism	Not provided		Provided	
Max. sewing speed	4,000 sti/min *1		3,200 sti/min	
Needle	DP x 5 #9 to #16 (For S type), DP x 5 #9 to #11 (For F type), DP x 5 #16 to #22 (G type)			
Gauge size	1/8" to 1-1/2" 3.2 to 38.1 mm	5/32" to 1-1/4" 4 to 31.8 mm	5/32" to 1" 4 to 25.4 mm	5/32" to 1" 4 to 25.4 mm
Lift of presser foot	12 mm by knee lifter, 5.5 mm by hand lifter lever, 9 mm by knee lifter with wiper			
Lubrication	New Defrix Oil No. 1			
Noise	<ul style="list-style-type: none"> • LH-4128 / 4128-7 - Equivalent continuous emission sound pressure level (L_{pA}) at the workstation : A-weighted value of 83.5 dB ; (Includes $K_{pA} = 2.5$ dB) ; according to ISO 10821- C.6.2 -ISO 11204 GR2 at 4000 sti/min. - Sound power level (L_{WA}) ; A-weighted value of 88.0 dB ; (Includes $K_{WA} = 2.5$ dB) ; according to ISO 10821- C.6.2 -ISO 3744 GR2 at 4000 sti/min. • LH-4168-7 - Equivalent continuous emission sound pressure level (L_{pA}) at the workstation : A-weighted value of 78.0 dB ; (Includes $K_{pA} = 2.5$ dB) ; according to ISO 10821- C.6.2 -ISO 11204 GR2 at 3200 sti/min. • LH-4188-7 - Equivalent continuous emission sound pressure level (L_{pA}) at the workstation : A-weighted value of 84.5 dB ; (Includes $K_{pA} = 2.5$ dB) ; according to ISO 10821- C.6.2 -ISO 11204 GR2 at 3200 sti/min. - Sound power level (L_{WA}) ; A-weighted value of 89.0 dB ; (Includes $K_{WA} = 2.5$ dB) ; according to ISO 10821- C.6.2 -ISO 3744 GR2 at 3200 sti/min. 			

*1 3,500 sti/min when the stitch length exceeds 4 mm.

*2 S : Standard, F : Foundation, G : Jeans

2. NAME OF EACH COMPONENT

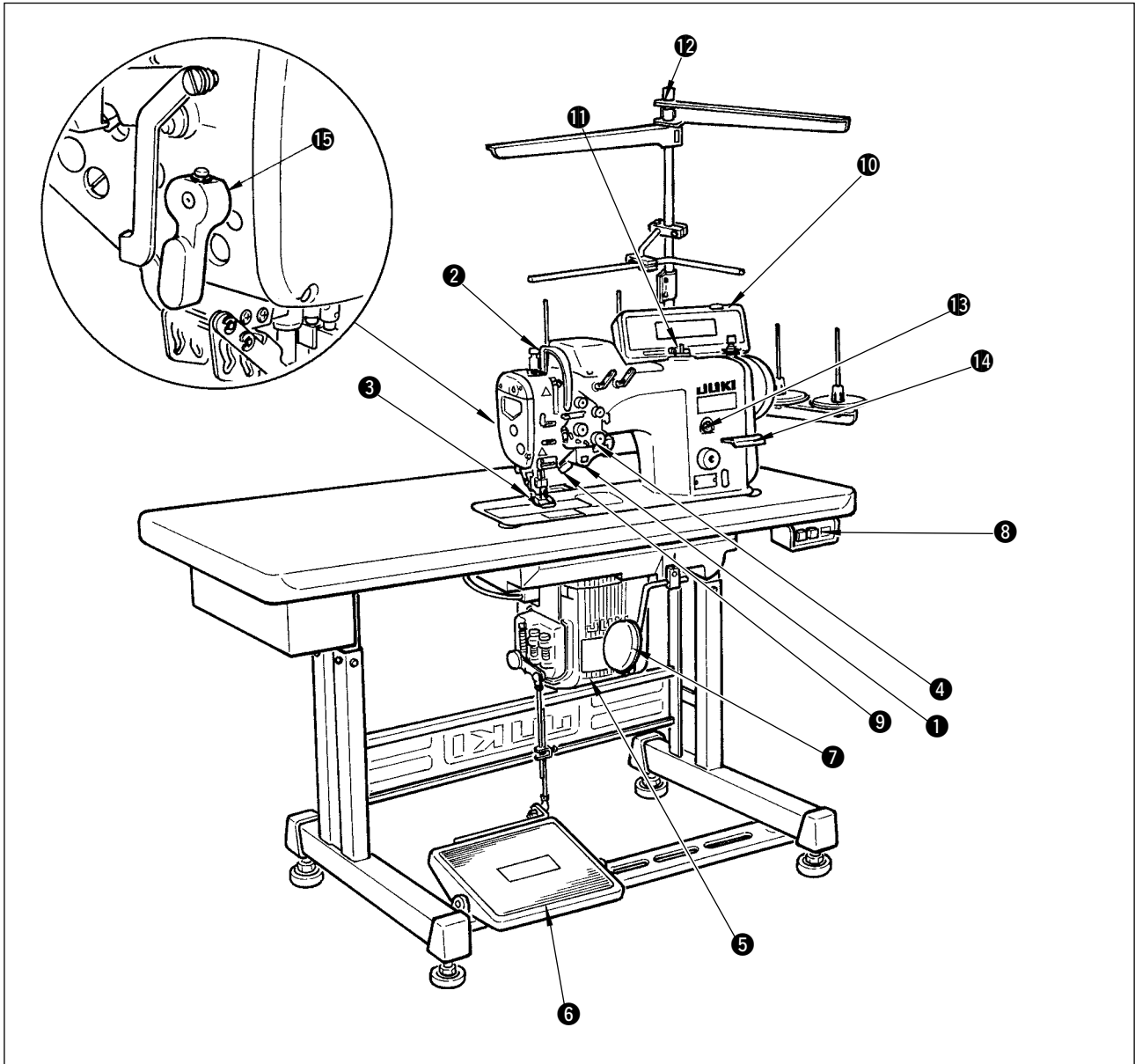

- ① Separately driven needle changeover switch
- ② Thread take-up cover
- ③ Finger guard
- ④ Thread tension controller
- ⑤ Control box

- ⑥ Pedal
- ⑦ Knee lifter lever
- ⑧ Power switch
- ⑨ Hand switch
- ⑩ Operation panel

- ⑪ Bobbin winder
- ⑫ Thread stand
- ⑬ Oil supply opening
- ⑭ Reverse feed control lever
- ⑮ Hand lifter lever

3. INSTALLATION

3-1. Installing the bottom cover

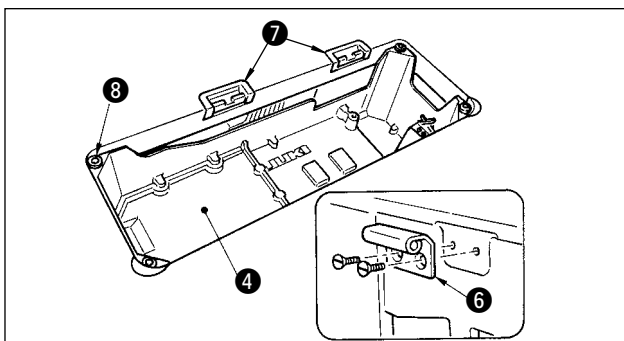
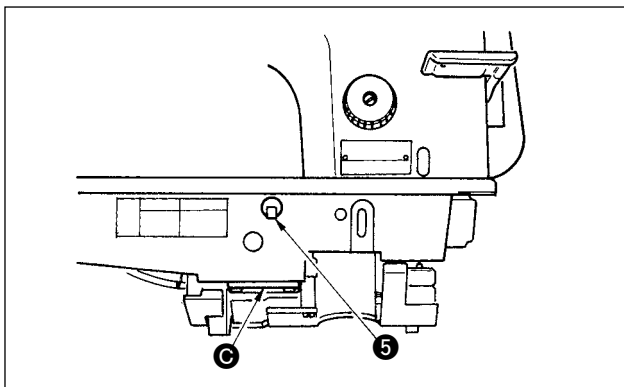
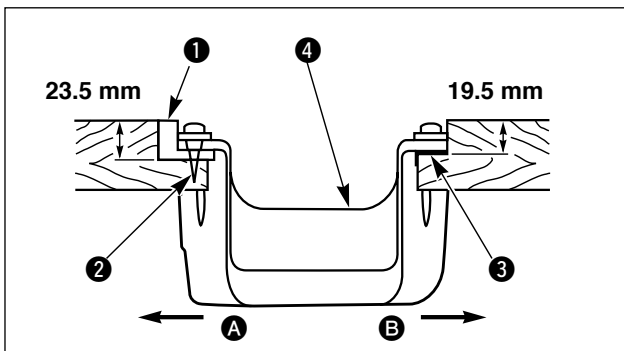
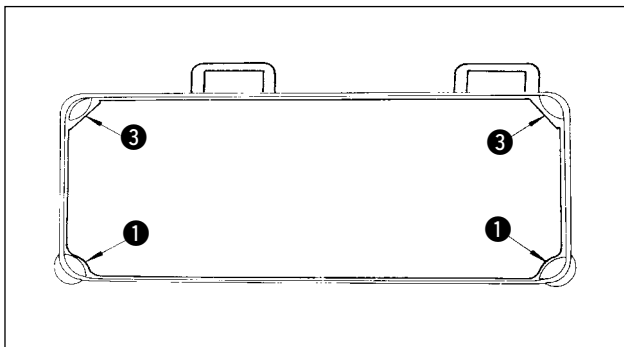

1) The bottom cover should rest on the four corners of the machine table groove.

2) Fix two head support rubber seats ① on the front side A to the protruding section of the machine table using nails ②. Fix two machine head cushion seats ③ on hinge side B using a rubber-based adhesive, Then place bottom cover ④ on the fixed seats.

3) Remove air vent cap ⑤ attached to the machine bed. (Be sure to attach cap ⑤ when transporting the machine head in the state that the machine head is removed from the machine table.)



If the sewing machine is operated without removing air vent cap ⑤, oil leakage from gear box portion C may occur.

4) Fit hinge ⑥ to the machine main body with screws.

Fit the machine head to table rubber hinges ⑦ and place it on head cushions ⑧ on the four corners.

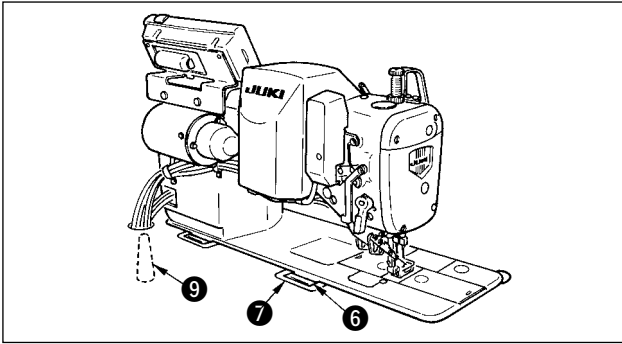

- 5) In case the AK-device is not provided, attach head support rod ⑨ to the machine table.

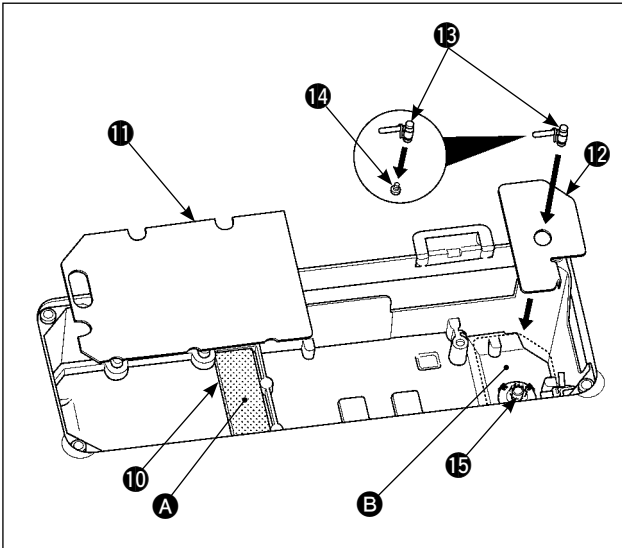

- 6) Place urethane filter ⑩ on ①. Then put sheet-metal (fine-mesh sheet) type filter ⑪ on the urethane filter.
Place sheet-metal (fine-mesh sheet) type filter ⑫ on ②.
Remove inlet port for circulation ⑬ fixed on the right hook driving shaft saddle. Remove cap ⑭ from the end of the inlet port. Then, securely insert the inlet port into filter ⑮ until it will go no further.



If inlet port for circulation ⑬ is not fully inserted into filter ⑮, a faulty circulation can occur.

3-2. Opening and closing of the control box (SC-910)

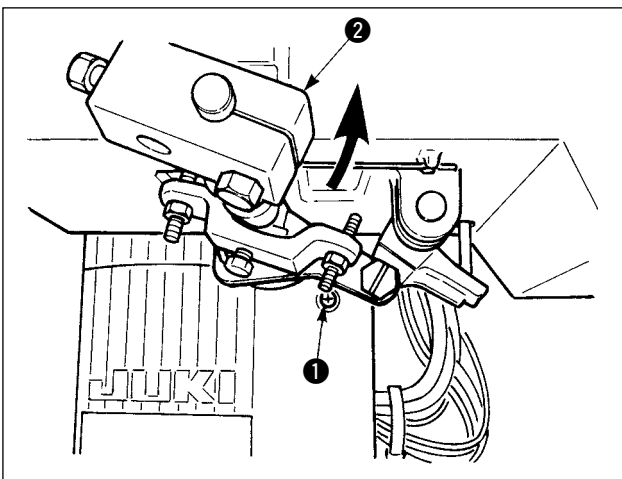

When opening and closing the control box, move the knee lifter components ② to the position where screw hole ① can be observed and perform the work.

For the connection of the cords and setting of the control box, refer to the Instruction Manual for SC-910 together with this Instruction Manual.

3-3. Adjusting the height of the knee lifter



WARNING :

Turn OFF the power before starting the work so as to prevent accidents caused by abrupt start of the sewing machine.

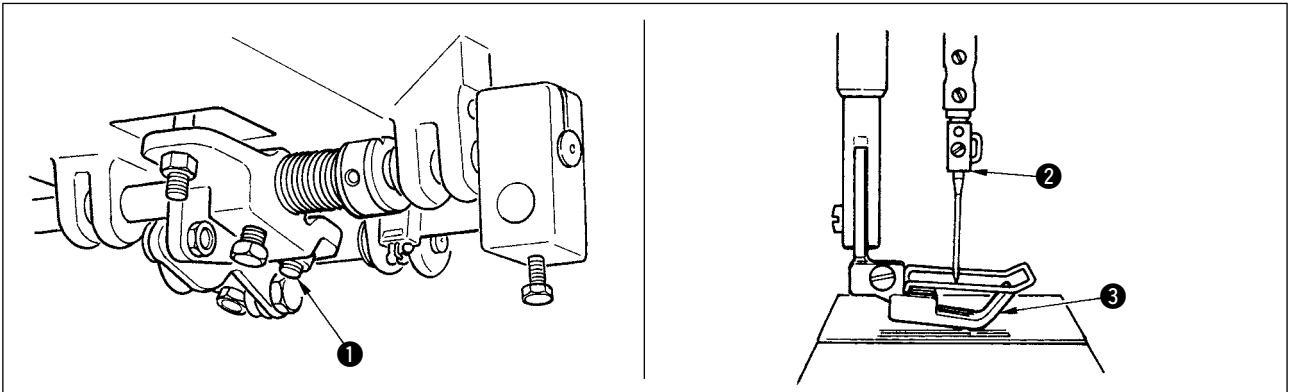

- 1) The standard height of the presser foot lifted using the knee lifter is 12 mm.
- 2) You can adjust the presser foot lift up to 13 mm using knee lifter adjust screw ①.



Do not operate the sewing machine in the state that the presser foot ③ is lifted by 12 mm or more since the needle bar ② comes in contact with the presser foot ③.

3-4. Installation of thread stand

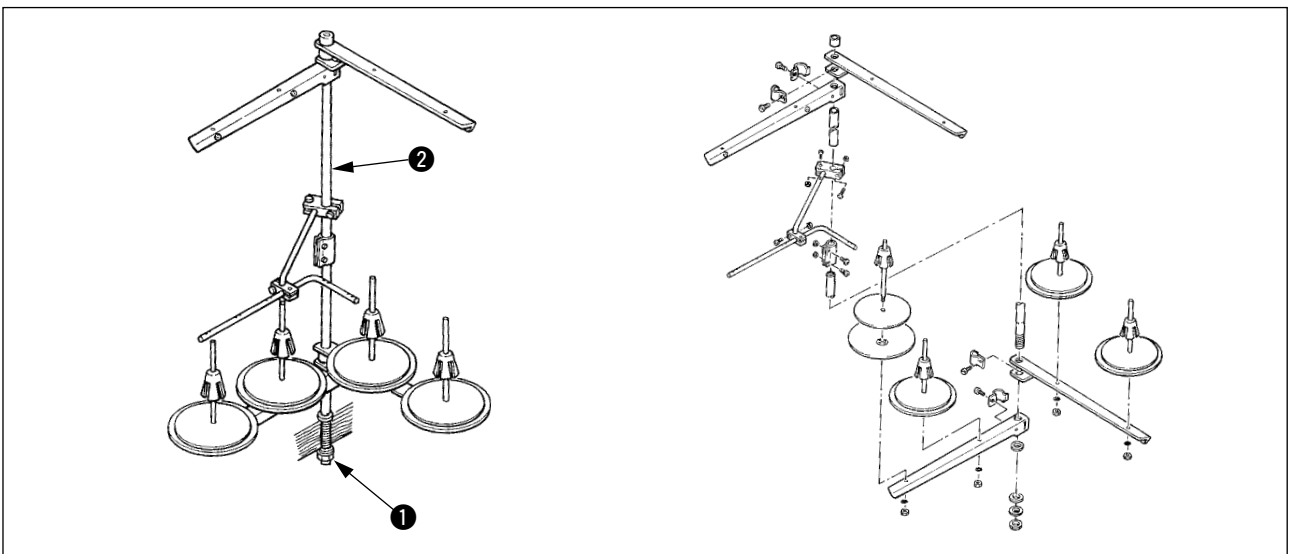

Assemble the thread stand, set it up on the machine table using the installation hole in the table and tighten nut ① gently. When you use power supplied by the overhead power line, pass the power supply cord through hollow spool rest rod ②.

3-5. Caution when installing the panel

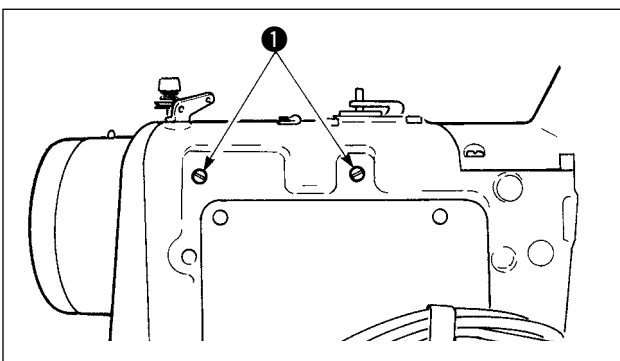

Use washers, toothed lock washers, and screws ① mounted on the machine head when installing the panel.



The screws attached to the panel may damage the screw holes since the pitch of the screws is different from that of the machine head.

3-6. Connecting the cord

(1) LH-4128,4128-7,4168-7,4188-7

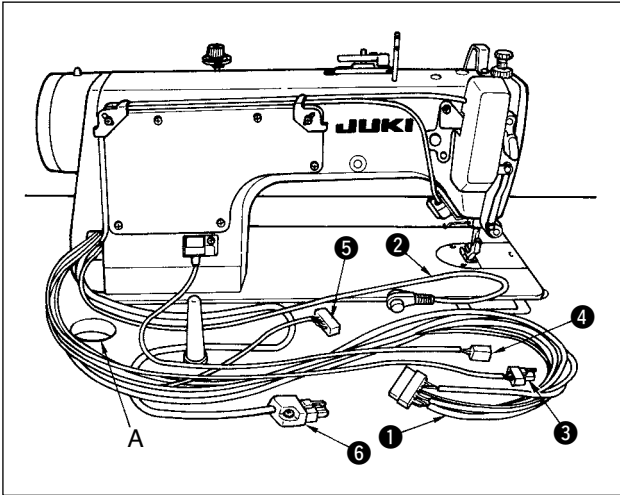

- 1) Pass the cords ① of the thread trimming solenoid, reverse-stitching solenoid, etc., and the cords of the synchronizer ②, safety switch ③, machine head 4P connector ④, motor signal ⑤, motor output ⑥ through hole A in the table to route them down under the machine table.

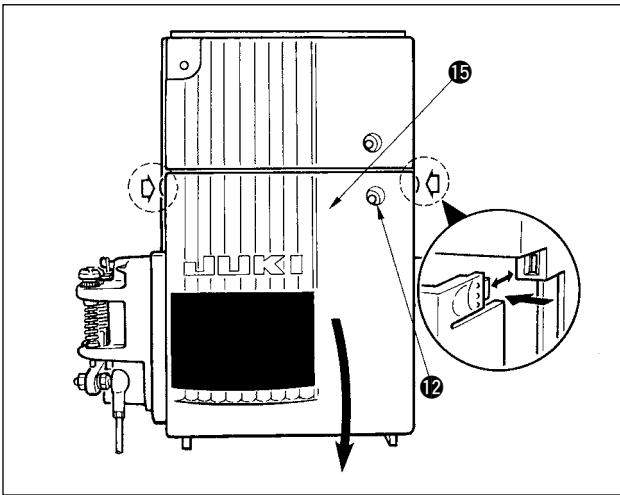

- 2) Loosen setscrew ⑫ in front cover ⑮.
- 3) Pressing the side of front cover ⑮ in the direction of the arrow, open the front cover toward you.



Be sure to open / close the front cover with your hands.

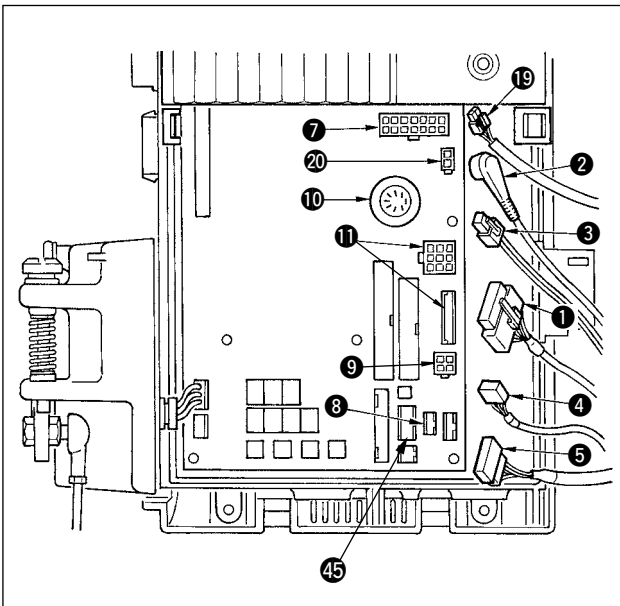

- 4) Connect 14P code ① coming from the machine head to connector ⑦ (CN46).
- 5) Connect 4P connector coming from the machine head ④ to connector ⑧ (CN31).
- 6) Connect 4P connector ③ (safety switch connector) coming from the machine head to connector ⑨ (CN48).
- 7) Connect 7P connector ② coming from the machine head to connector ⑩ (CN30).
- 8) Connect connector ⑤ coming from the machine head to connector ⑪ (CN38, CN39). (Connect 8P connector to CN38 and in case of 9Pconnector, connect to CN39.)
- 9) When the optional AK125 device is attached, connect 2P connector ⑲ coming from the AK device to connector ⑳ (CN40).



Be sure to securely insert the respective connectors after checking the inserting directions since all connectors have the inserting directions. (When using a type with lock, insert the connectors until they go to the lock.)

The sewing machine is not actuated unless the connectors are inserted properly. In addition, not only the problem of error warning or the like occurs, but also the sewing machine and the control box are damaged.

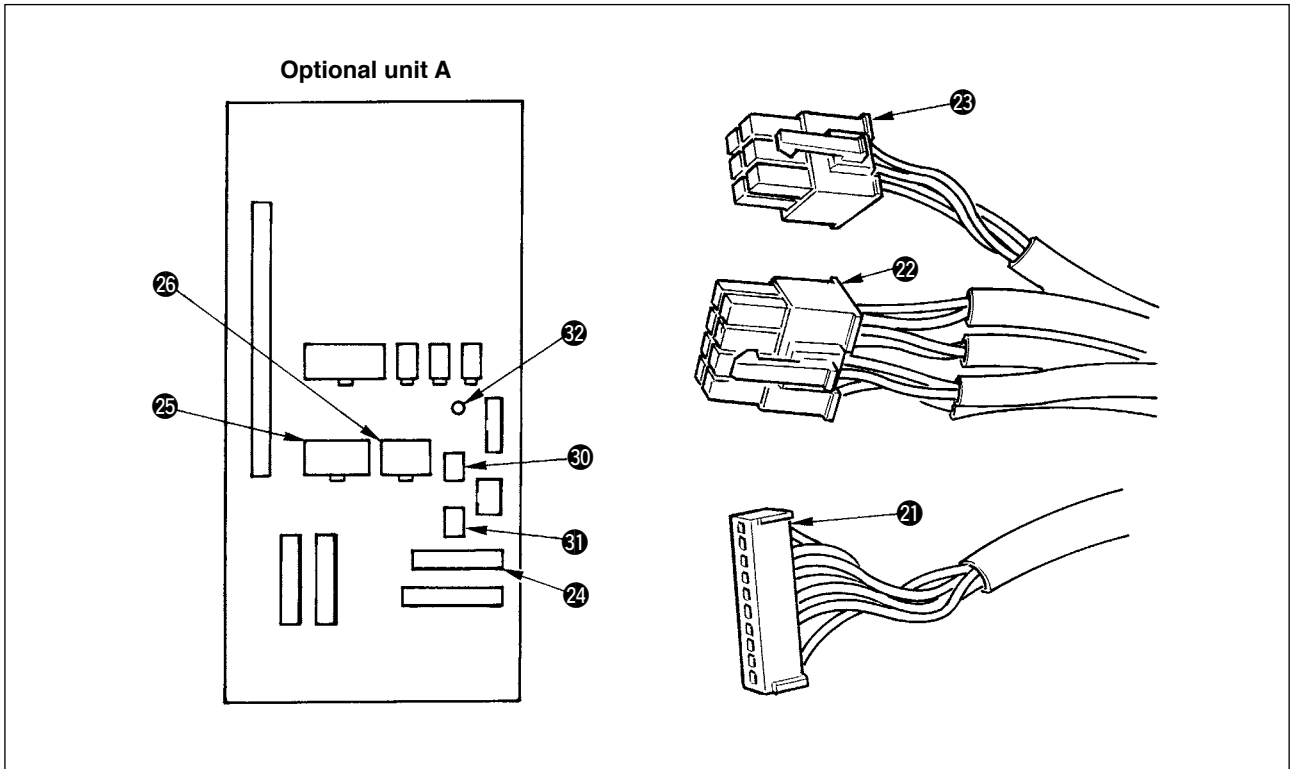

(2) 4168-7,4188-7

In addition to “3-6. (1)”, connect the cords below.

- 1) Pass separately driven needle changeover switch cord ①, separately driven needle solenoid cord ② and separately driven needle sensor cord ③ through hole A in the table to route them down under the machine table.
- 2) Connect 10P connector ① coming from the machine head to connector ④ (CN125).
- 3) Connect 8P connector ② coming from the machine head to connector ⑤ (CN129).
- 4) Connect 6P connector ③ coming from the machine head to connector ⑥ (CN128).
- 5) Remove the cord extending from ⑦ (COM) from ⑧ (BNC) and connect it to ⑨ (LH).

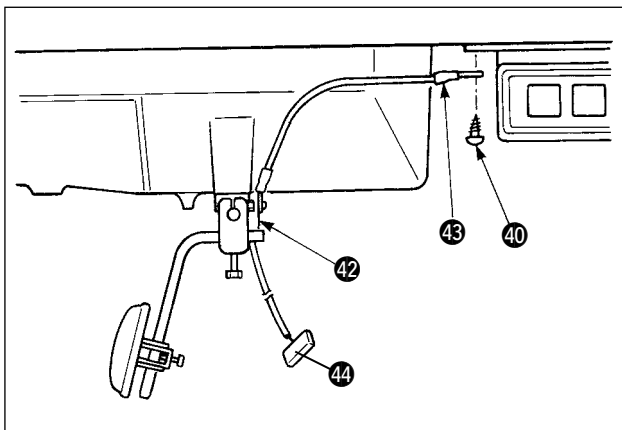

- 6) Remove setscrew ⑩ located on the left-hand side of the power switch, and place the point of earth cord (asm.) ⑬ coming from knee lifter detecting sensor plate (asm.) ⑫ to the setscrew. Then tighten the setscrew.



When the earth cord has not been connected, malfunction will be caused.

- 7) Connect knee lifter detection sensor connector ⑭ to connector ⑮ (CN32).

3-7. Managing the cord

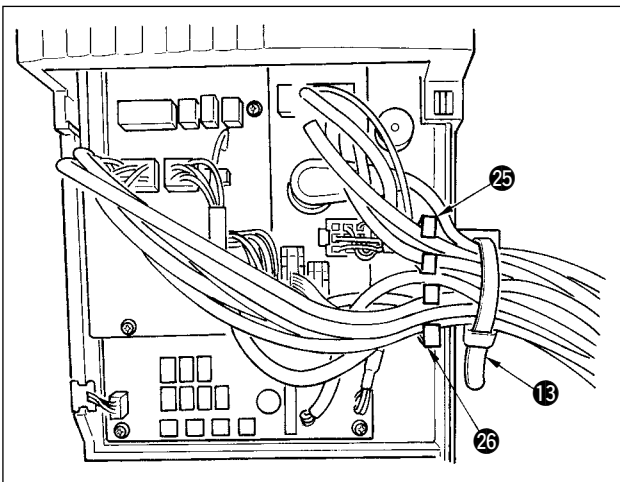
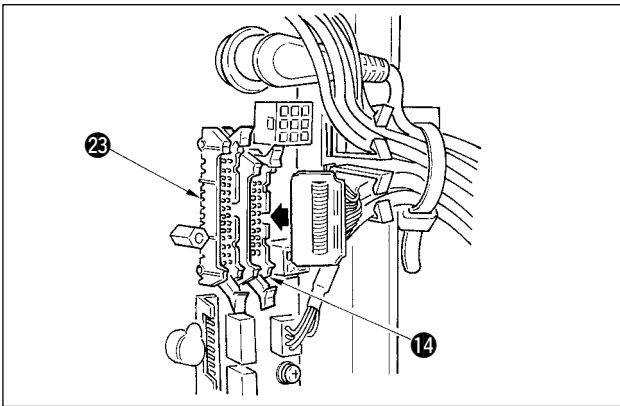
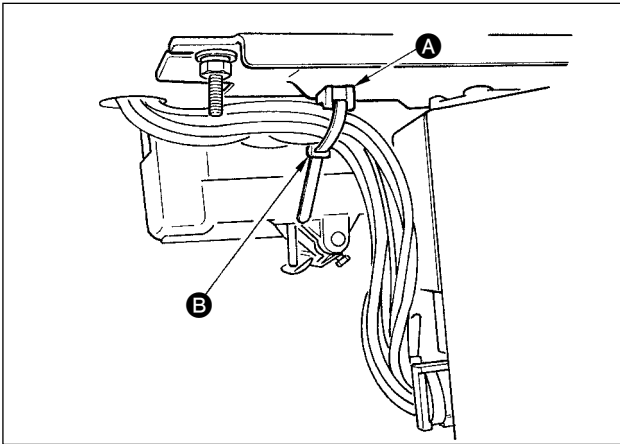

- 1) Fix all cables coming from the machine head with cable clip band **B** attached to tie-mount **A**.

[Connection of the connector for CP panel]

Exclusive connectors are prepared for connection of the connector for CP-160.

Paying attention to the orientation of the connector, connect it to connector **14** located on the circuit board. After connecting, securely lock the connector.

[Connecting for IP panel]

The connector for connecting IP-100 and IP-110 are prepared.

When connecting, insert the connector until it is locked to **23**.

- 2) After inserting the connector, put all cords together with cable clip band **13** located on the side of the box. At this time, bundle the cords (connector CN46) of thread trimming solenoid, reverse feed solenoid, etc., AK cord (connector CN40) and motor signal cord (connector CN39) to wire saddle **25**, bundle detector cord (connector CN30) above wire saddle **25**, knee lifter detection sensor cord (connector CN32) between wire saddles **25** and **26** and other cords to wire saddle **26**.



1. Fix the cord clamp and the cable clip band following the attaching procedure.
2. When removing the connector, remove it from the wire saddle and remove it while pressing the hook of the cable clip band.

How to fix cable clip band **13**

Pull

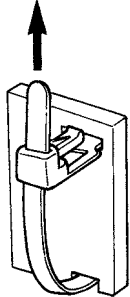

Pull

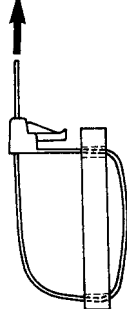

How to remove cable clip band

Push

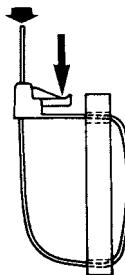

Push Push the hook.

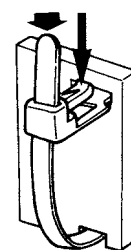

Pushing the hook portion, push the band to remove it.



1. Fix the cable clip band following the attaching procedure as shown in the figure.
2. To remove the cable clip band, push the cable clip band until it comes off while pressing the hook of the band following the removing procedure as shown in the figure.

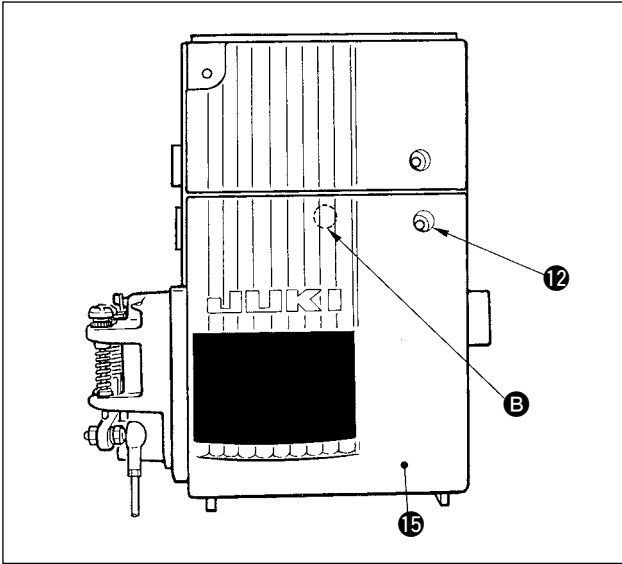

- 3) Close front cover **15** while paying attention to pinching of the wire.
Lightly press portion **B** and insert front cover **15** with “click”.
- 4) After that, fix it with the screw **12**.

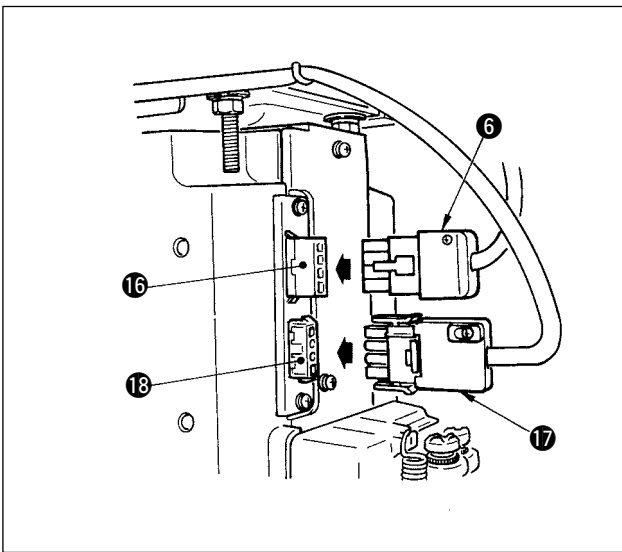

- 5) Connect motor output cord **6** to connector **16** located on the side of the box.
- 6) Connect connector 4P **17** of the power switch to connector **18**.



Route the motor output cord from the front face of the box.

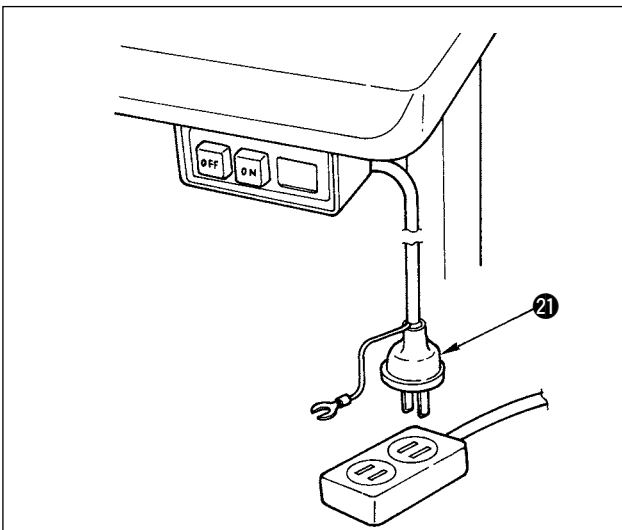

- 7) Make sure that the power switch is turned OFF and insert power supply cord **21** coming from the power switch into the power plug socket. (Illustration is for the Japanese specification 100V type.)



1. Top end of power supply cord varies in accordance with destination or supply voltage. Check again the supply voltage and the voltage designated on the control box when installing the switch.
2. Prepare the power switch conformed to the safety standard.
3. Be sure to connect the ground wire (green / yellow).

3-8. Adjusting the knee lifter detection seat (asm.)

Conditions : LED starts lighting at presser foot lift of 5 mm.

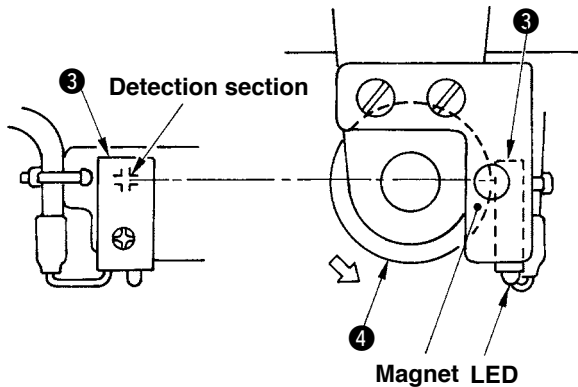
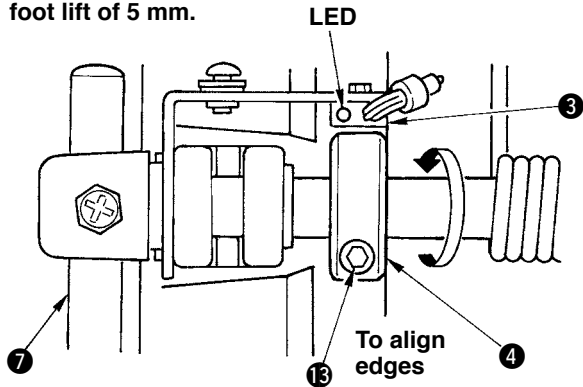

* For explanation, the figure above omits knee pad plate and the like.

- 1) Turn ON the power.
- 2) Press knee pad plate ⑦ and lift the presser foot by 5 mm from the top surface of throat plate.
- 3) Turn knee lifter detection seat (asm.) ④ in the direction of the arrow and fix it at the position where LED of knee lifter detection sensor ③ starts lighting with setscrew ⑬. At this time, align the edge of detection seat (asm.) ④ with that of knee lifter detection sensor ③.



When the edges of knee lifter detection sensor ③ and knee lifter detection seat (asm.) ④ are not aligned, detection trouble will be caused.

- 4) Confirm that LED goes out when knee pad plate ⑦ is released.



It is adjusted so that the knee lifting motion is detected when presser foot is lifted by 5 mm. When using it with the lift amount of less than 5 mm, reduce the standard adjustment value and re-adjust according to step 3).

- 5) When the magnet of knee lifter detection seat (asm.) ④ comes near the detection section (+ mark section) of knee lifter detection sensor ③, it detects that knee lifting has been performed and LED lights up.

4. PREPARATION OF THE SEWING MACHINE

4-1. Lubrication



WARNING :

1. Do not connect the power plug until the lubrication has been completed so as to prevent accidents due to abrupt start of the sewing machine,
2. To prevent the occurrence of an inflammation or rash, immediately wash the related portions if oil adheres to your eyes or other parts of your body.
3. If oil is mistakenly swallowed, diarrhea or vomiting may occur. Put oil in a place where children cannot reach.

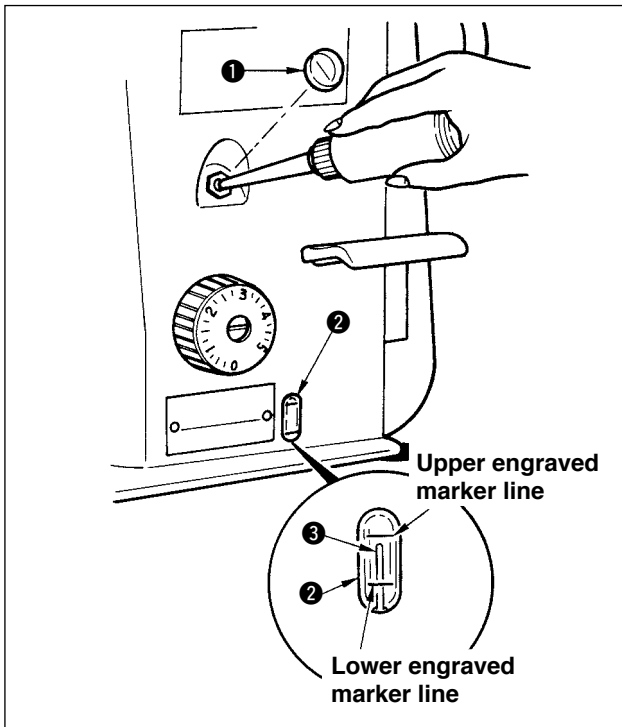

Fill the oil tank with oil for hook lubrication before operating the sewing machine.

- 1) Remove oil hole cap ❶ and fill the oil tank with JUKI New Defrix Oil No. 1 using the oiler supplied with the machine.
- 2) Fill the oil tank with the oil until the top end of oil amount indicating rod ❸ aligns with the upper engraved marker line of oil amount indicating window ❷.

If the oil is filled excessively, it will leak from the air vent hole in the oil tank or proper lubrication will be not performed. So, be careful.

- 3) When you operate the sewing machine, refill oil if the top end of oil amount indicating rod ❸ comes down to the lower engraved marker line of oil amount indicating window ❷.



- When filling the oil tank with the oil initially, make sure that the oil amount indicating rod works. When it does not work at this time, make it work by tilting the sewing machine once.
- When you use a new sewing machine or a sewing machine after an extended period of disuse, use the sewing machine after performing break-in at 3,000 sti/min or less.
- For the oil for hook lubrication, purchase JUKI New Defrix Oil No. 1 (Part No. : MDFRX1600C0).
- Be sure to lubricate clean oil.



When bringing the machine into use, the oil quantity in the oil tank will decrease until the circulation filter is filled with oil. When the top of the oil quantity indicating bar goes down under the lower engraved marker line, add oil again so that the indicating bar rests in the range between the upper and lower engraved marker lines.

4-2. Cleaning the filter

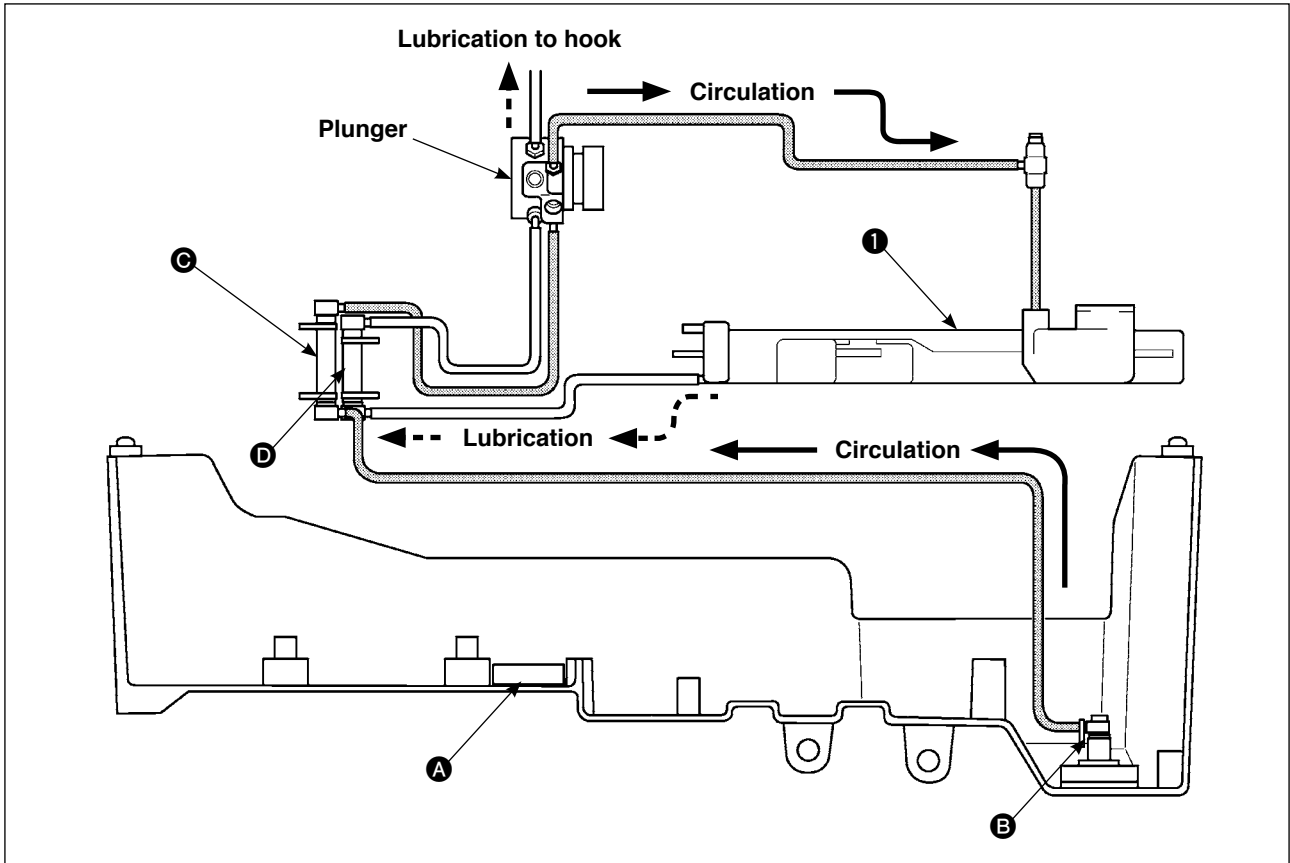

To ensure longer service life of your machine, be sure to periodically (approximately once every three months) clean up the above-stated filter section (urethane filter **A**, circulation filter **B**, plunger filter **C** and plunger filter 2 **D**). When the filter is clogged, lubrication trouble will occur and break-down will be caused.

In addition, when the oil becomes dirty, replace the oil gathered in the oil tank **1** and the under cover.

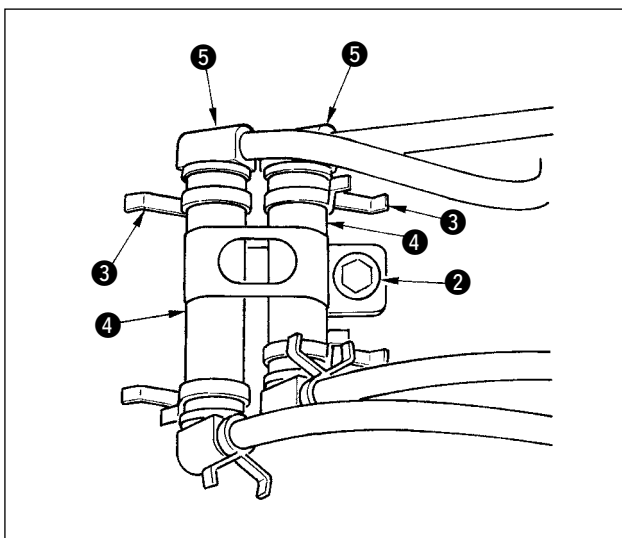

■ Cleaning the plunger filter

- 1) Loosen setscrew **2** to remove it from the bed.
- 2) Loosen pipe stopper **3**, and remove tube **4** and joint **5**.
- 3) After removing dust adhered to the net section of joint **5**, return the filter to its home position.

4-3. Adjusting the amount of oil in the hook



WARNING :

Turn OFF the power before starting the work so as to prevent accidents caused by abrupt start of the sewing machine.

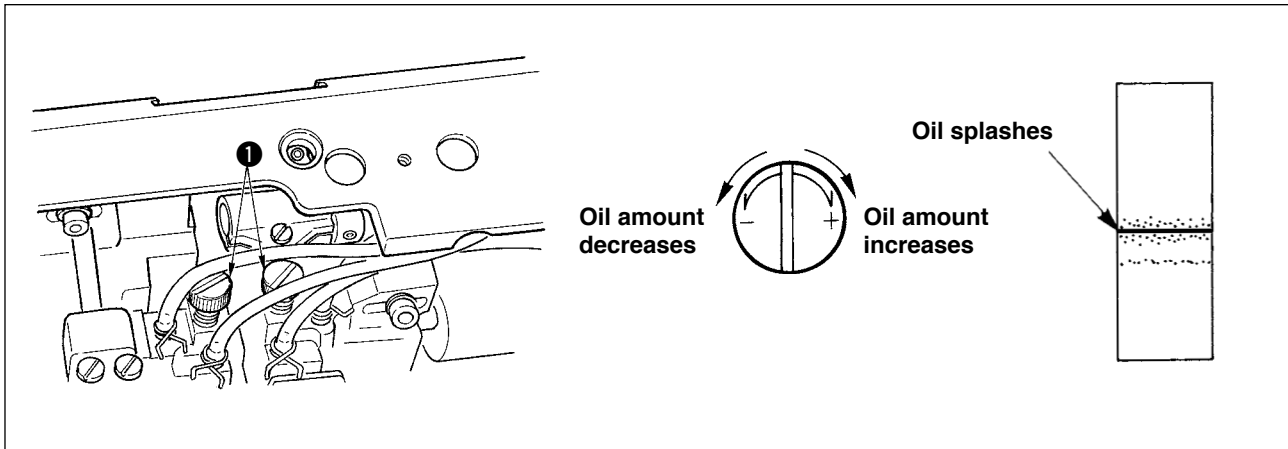

Adjust the amount oil using adjusting screw ①. Turn screw ① clockwise to increase the amount of oil in the hook or counterclockwise to decrease it. Measure the amount of oil in five seconds. When the amount of oil is excessively decreased, break-down will be caused. So, be careful.

4-4. Attaching the needles



WARNING :

Turn OFF the power before starting the work so as to prevent accidents caused by abrupt start of the sewing machine.

LH-4168-7, 4188-7

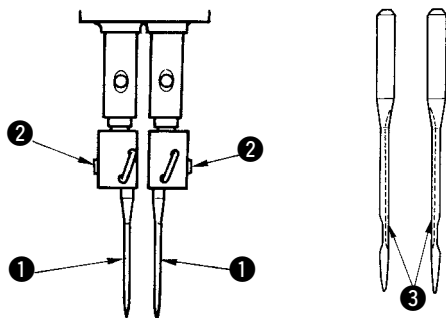

Switch "off" the motor.

Use DPx5 needles.

- 1) Turn the handwheel until the needle bar has come up to the highest point of its stroke.
- 2) Loosen needle clamp screws ② and pick up two needles ① in the way that their grooves ③ are facing outwards.
- 3) Insert the needles into the needle clamp as far as they will go.
- 4) Tighten needle clamp screws ② firmly.

LH-4128, 4128-7

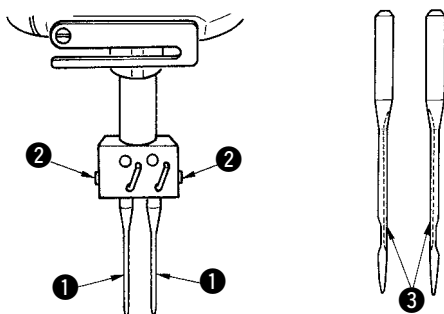

4-5. How to take out the bobbin case



WARNING :

Turn OFF the power before starting the work so as to prevent accidents caused by abrupt start of the sewing machine.

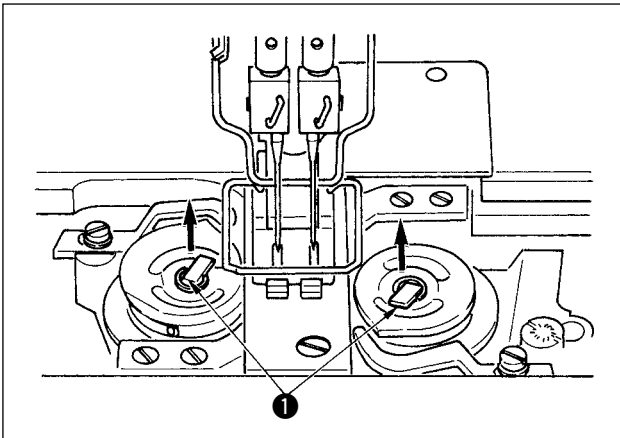

- 1) Lift latch ① and take out the bobbin case and the bobbin together.
- 2) Hold the bobbin case by latch raised, put it into the shaft in the hook correctly and release the latch.

4-6. Inserting a bobbin in a bobbin case

LH-4168-7, 4188-7

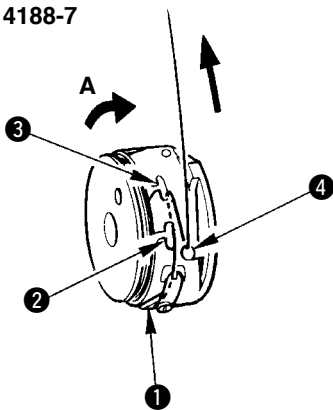

[LH-4168-7 and 4188-7]

- 1) Set a bobbin to the bobbin case so that the bobbin turns in the direction of arrow mark A.
- 2) Pass the thread through thread slit ① in the bobbin case and draw the thread and pull the thread so that it passes under the tension spring.
- 3) Pass thread through another thread slit ② then, pass it through thread slit ③ on the bobbin case from the inside.
- 4) Put the thread on bobbin threads slack preventer spring ④.

LH-4128, 4128-7

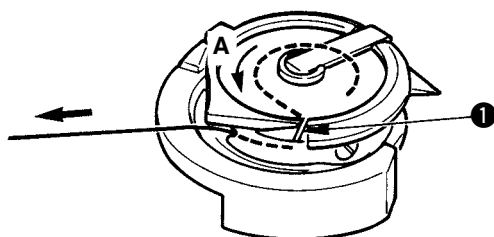

[LH-4128 and 4128-7]

- 1) Set a bobbin to the bobbin case so that the bobbin turns in the direction of arrow mark A.
- 2) Pass the thread through thread slit ① in the hook and draw the thread and pull it so that it passes under the tension spring.

4-7. Threading the machine head



WARNING :

Turn OFF the power before starting the work so as to prevent accidents caused by abrupt start of the sewing machine.

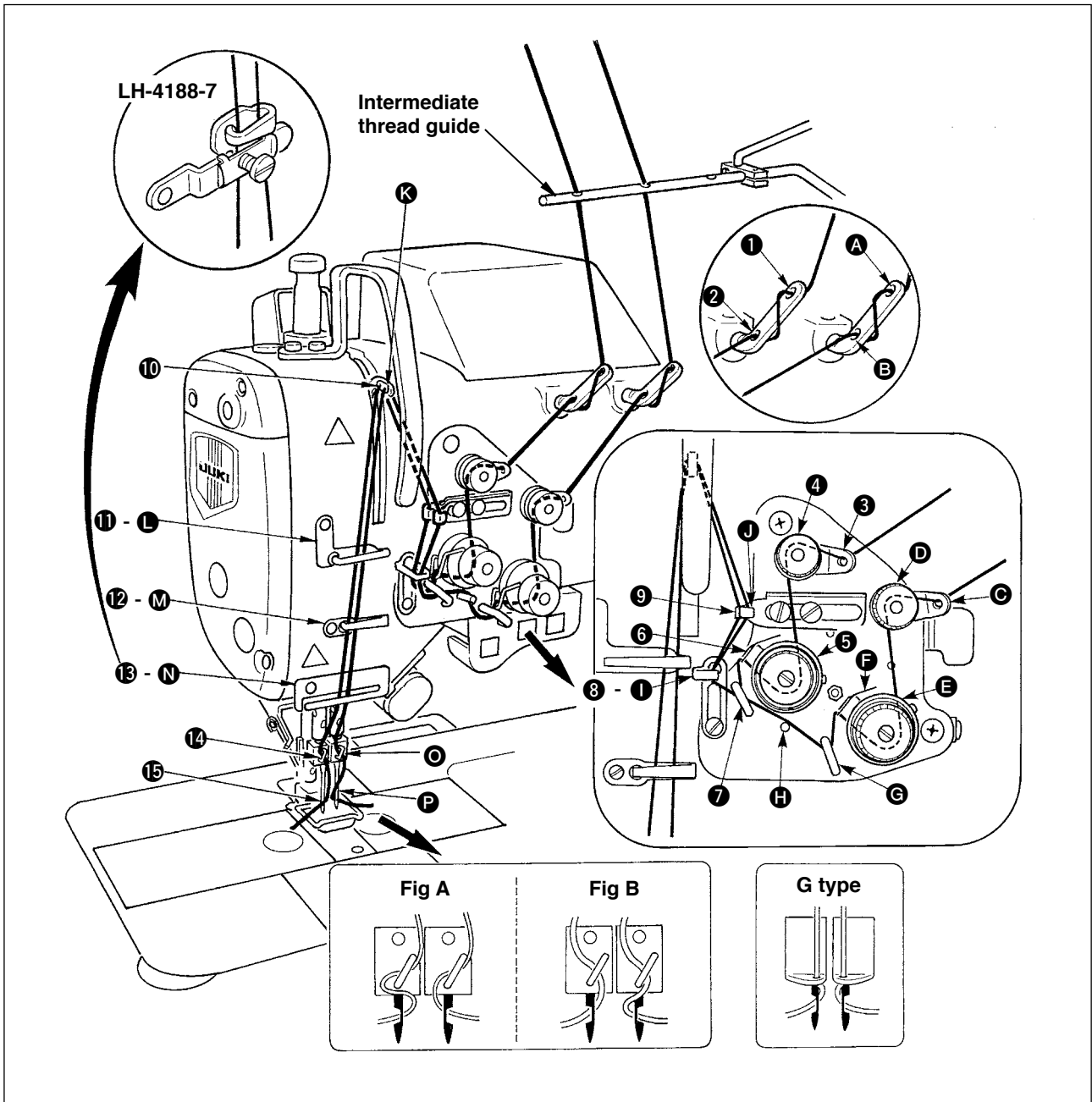

Thread the machine head following the order as illustrated in the figure.

Pass the left-hand needle thread, toward the machine head, in the order of ① to ⑮. Pass the right-hand needle thread in the order of ① to ⑰.



Be careful of threading of needle clamp thread guides (⑭, ⑯).

- Figure A for thin filament thread of #60 or less
- Figure B for thick filament thread and polyester spun thread of #50 or more

4-8. Thread tension

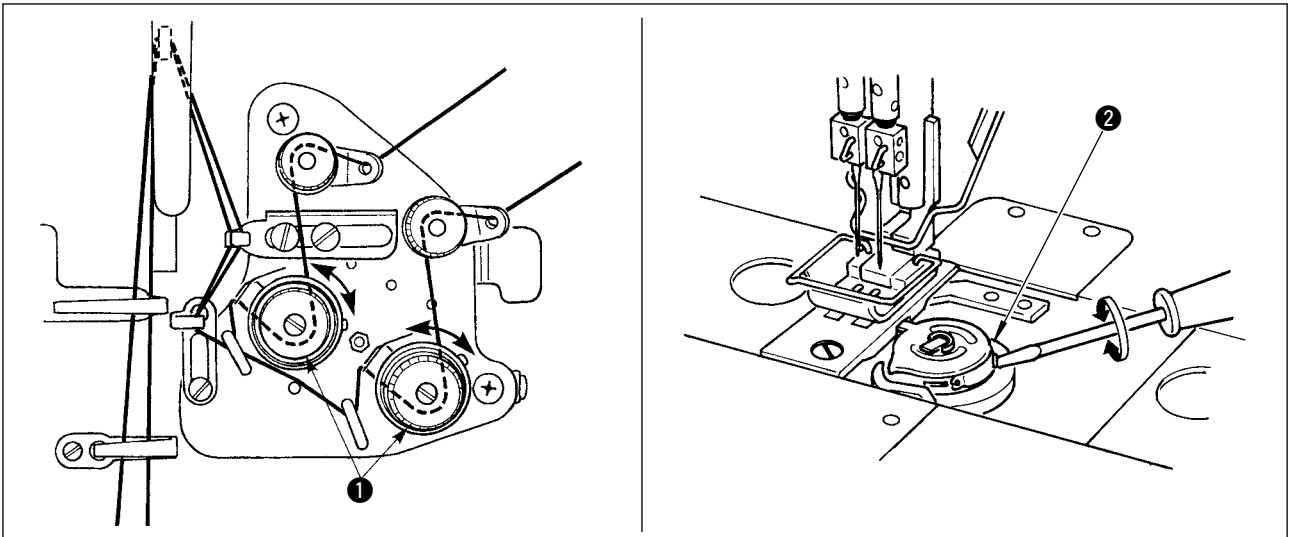

- 1) Needle thread tension
Turn thread tension nut No. 2 **1** clockwise to increase or counterclockwise to reduce the needle thread tension.
- 2) Bobbin thread tension
Turn tension adjusting screw **2** clockwise to increase or counterclockwise to reduce the bobbin thread tension.

4-9. Thread take-up spring



WARNING :

Turn OFF the power before starting the work so as to prevent accidents caused by abrupt start of the sewing machine.

(1) When you want to change the stroke of the thread take-up spring

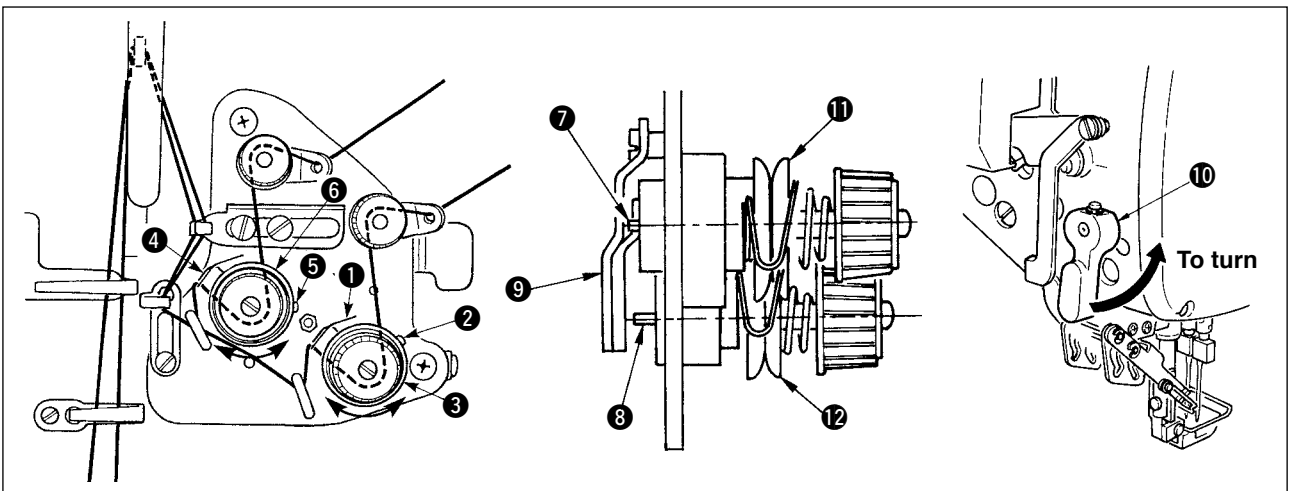

- 1) Stroke of thread take-up spring **1** on the right is adjustable by moving thread tension No. 2 asm. **3** to the left or right after loosening thread tension No. 2 setscrew **2**.
- 2) Stroke of thread take-up spring **4** on the left is adjustable by moving thread tension No. 2 asm. **6** to the left or right after loosening thread tension No. 2 setscrew **5**.
- 3) Move thread tension No. 2 asm. **3** and **6** to the right to increase or to the left to decrease the stroke of the thread take-up spring.



When adjusting the stroke of thread take-up springs **1** and **4**, thread release pins **7** and **8** should not come in contact with disk release plate **9**.

In addition, make sure that thread tension disks **11** and **12** securely rise when hand lifter lever **10** is turned in the direction of the arrow.

(2) When you want to change the tension of the thread take-up spring

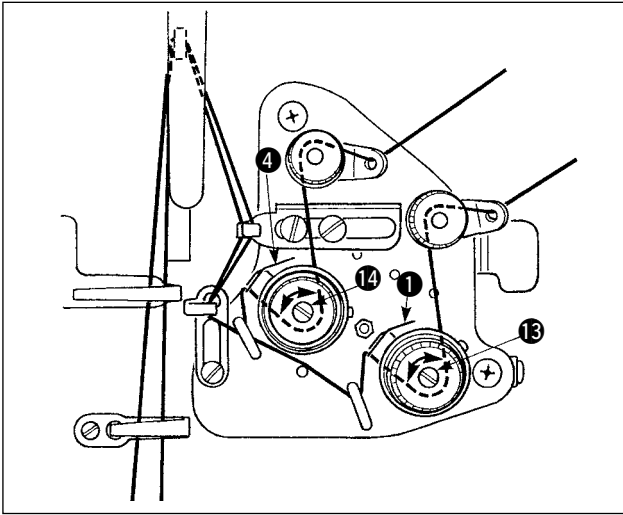

- 1) Tension of thread take-up spring ① on the right is adjustable by turning spring stud ⑬ to the right to increase or to the left to reduce.
- 2) Tension of thread take-up spring ④ on the left is adjustable by turning spring stud ⑭ to the right to increase or to the left to reduce.

4-10. Adjusting the stitch length

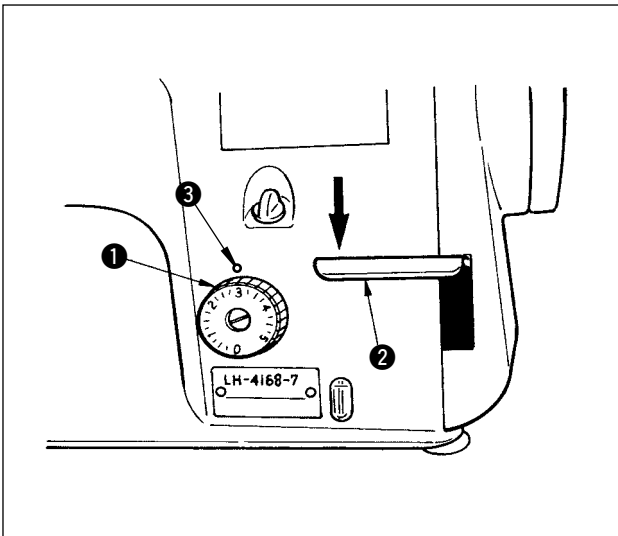

Turn stitch dial ① counterclockwise (clockwise) to set the value on the dial corresponding to a desired stitch length to the marker dot ③ engraved on the machine arm.

When it is hard to turn stitch dial ①, turn it while slightly depressing reverse feed control lever ②.

• Reverse feed operation

- 1) Depress reverse feed control lever ②.
- 2) Reverse stitches are made as long as you keep depressing the lever.
- 3) Release lever, and the machine will run forward.

4-11. Winding the bobbin thread

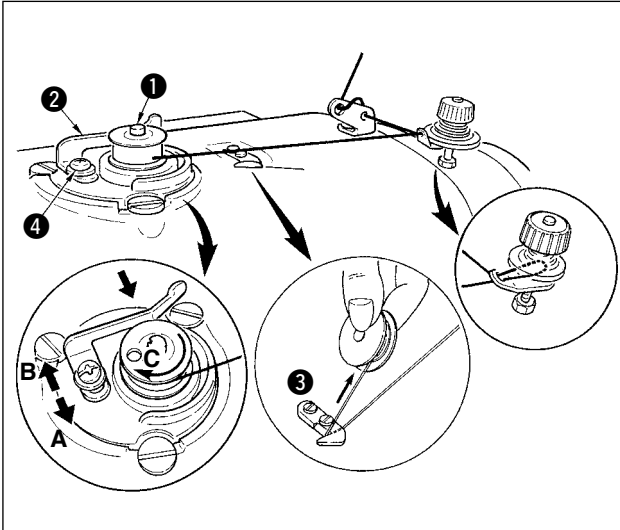

- 1) Insert the bobbin deep into the bobbin winder spindle ① until it will go no further.
- 2) Pass the bobbin thread pulled out from the thread tension controller located on the right side of the thread stand as shown in the figure and wind clockwise the end of the bobbin thread on the bobbin several times.
(In case of the aluminum bobbin, after winding clockwise the end of the bobbin thread, wind counterclockwise the thread coming from the bobbin thread tension several times to wind the bobbin thread with ease.)
- 3) Press the bobbin winder trip latch ② in the direction of A and start the sewing machine. The bobbin rotates in the direction of C and the bobbin thread is wound up. The bobbin winder spindle ① automatically as soon as the winding is finished.
- 4) Remove the bobbin and cut the bobbin thread with the thread cut retainer ③.
- 5) To adjust the winding amount of the bobbin thread, loosen setscrew ④ and move bobbin winder trip latch ② to the direction of A or B. Then tighten setscrew ④.

To the direction of A : Decrease

To the direction of B : Increase

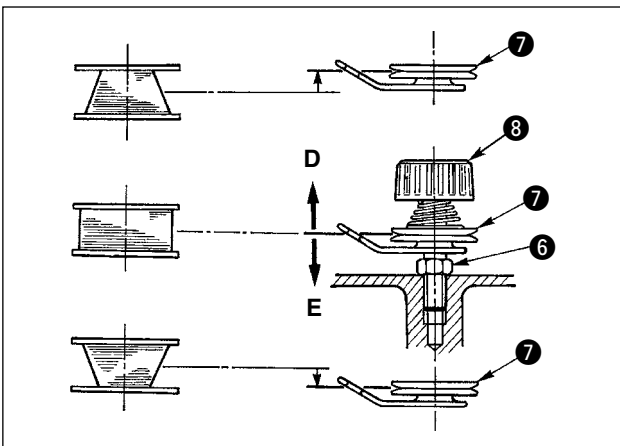

- 6) In case that the bobbin thread is not wound evenly on the bobbin, loosen the nut ⑥ and turn the bobbin thread tension to adjust the height of the thread tension disk ⑦.
 - It is the standard that the center of the bobbin is as high as the center of the thread tension disk.
 - Move the position of the thread tension disk ⑦ to the direction of D as shown in the figure on the left when the winding amount of the bobbin thread on the lower part of the bobbin is excessive and to the direction of E as shown in the figure on the left when the winding amount of the bobbin thread on the upper part of the bobbin is excessive. After the adjustment, tighten the nut ⑥.
- 7) To adjust the tension of the bobbin winder, turn the thread tension nut ⑧.



1. When winding the bobbin thread, start the winding in the state that the thread between the bobbin and thread tension disk ⑦ is tense.
2. When winding the bobbin thread in the state that sewing is not performed, remove the needle thread from the thread path of thread take-up and remove the bobbin from the hook.
3. There is the possibility that the thread pulled out from the thread stand is loosened due to the influence (direction) of the wind and may be entangled in the handwheel. Be careful of the direction of the wind.

4-12. Adjusting the needle stop position



WARNING :

Turn OFF the power before starting the work so as to prevent accidents caused by abrupt start of the sewing machine.

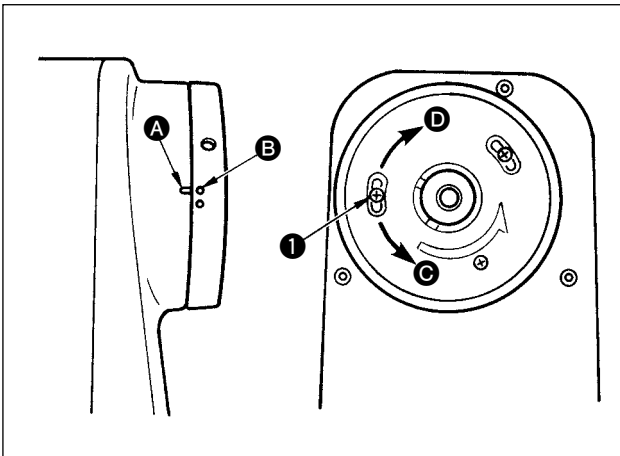

(1) Stop position after thread trimming

- 1) The standard needle stop position is obtained by aligning marker dot **A** on the pulley cover with white marker dot **B** on the handwheel.
- 2) Stop the needle in UP position, turn OFF the power, and loosen screw **1** to perform adjustment within the slot of the screw. The needle stop timing is advanced if you move the screw in the direction of **C**. The needle stop timing is delayed if you move the screw in the direction of **D**.



Do not operate the machine with screw **1 loosened. Just loosen the screw, and do not remove it.**

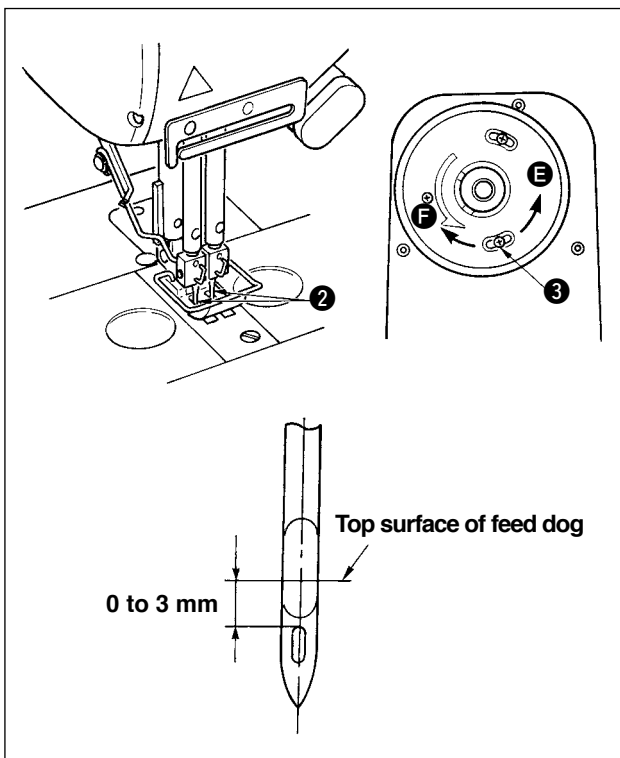

(2) Lower stop position

- 1) The DOWN needle stop position when the pedal is returned to the neutral position after the front part of the pedal is depressed is between the position where the needle pierces the feed dog and the upper end of needle eyelet aligns the top surface of feed dog and that where needle sinks by 3 mm.
- 2) The same as UP stop, stop needle **2** in DOWN position, turn OFF the power, and loosen screw **3** to perform adjustment within the slot of the screw. The needle stop timing is advanced if you move the screw in the direction of **E**, and the timing is delayed if you move the screw in the direction of **F**.



Do not operate the machine with screw **3 loosened. Just loosen the screw, and do not remove it.**

4-13. Pedal pressure and pedal stroke



WARNING :

Turn OFF the power before starting the work so as to prevent accidents caused by abrupt start of the sewing machine.

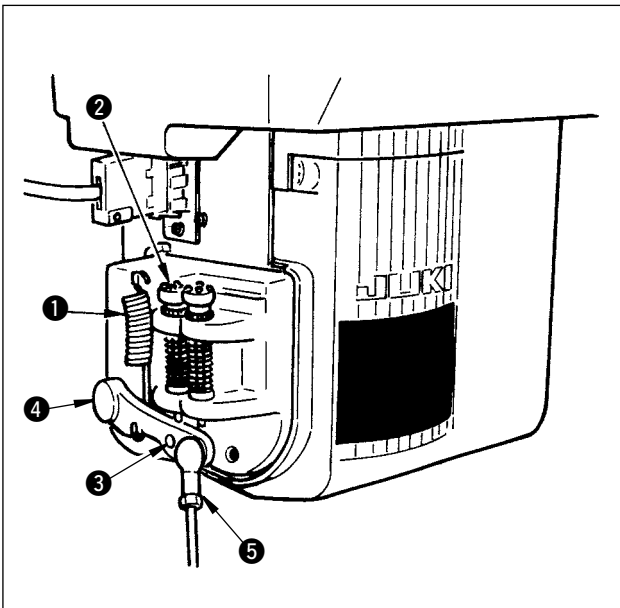

(1) Adjusting the pressure required to depress the front part of the pedal

- 1) This pressure can be adjusted by altering the position of lever ④ of pedaling pressure adjust spring ①.
- 2) The pressure decreases when you hook the spring on the left side.
- 3) The pressure increases when you hook the spring on the right side.

(2) Adjusting the pressure required to depress the back part of the pedal

- 1) This pressure can be adjusted using regulator screw ②.
- 2) The pressure increases as you turn the regulator screw in.
- 3) The pressure decreases as you turn the screw out.

(3) Adjusting the pedal stroke

- 1) The pedal stroke decreases when you insert connecting rod ⑤ into the left hole ③. (Both depressing and returning of the pedal become heavy.)

4-14. Adjustment of the pedal

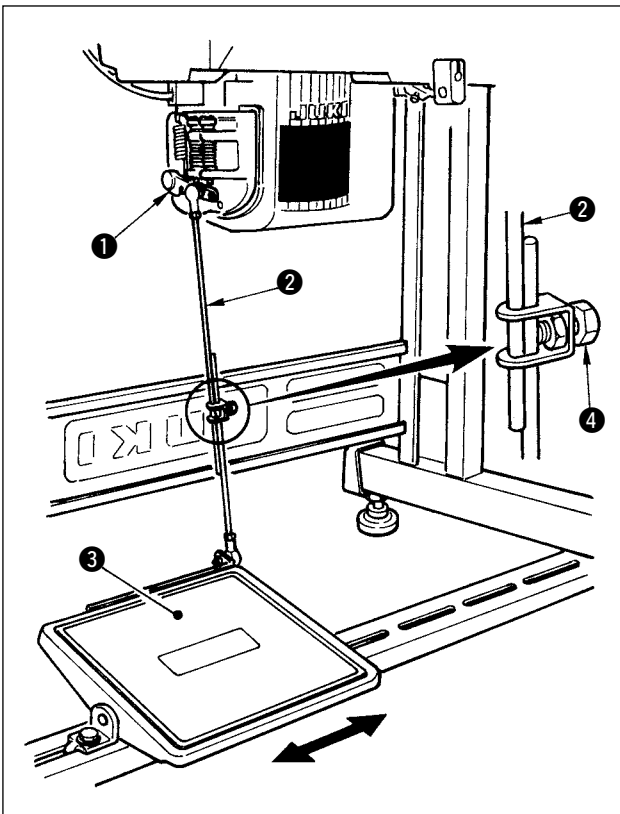

(1) Installing the connecting rod

- 1) Move pedal ③ to the right or left as illustrated by the arrows so that motor control lever ① and connecting rod ② are straightened.

(2) Adjusting the pedal angle

- 1) The pedal tilt can be freely adjusted by changing the length of the connecting rod.
- 2) Loosen adjust screw ④, and adjust the length of connecting rod ②.

5. OPERATION OF THE SEWING MACHINE

5-1. Pedal operation

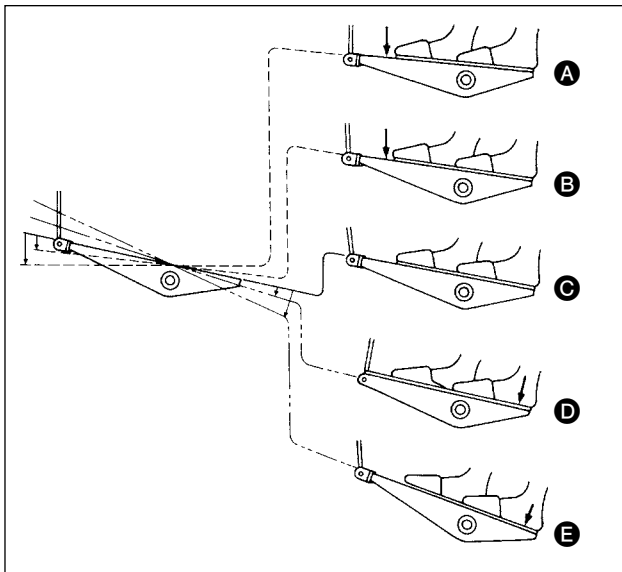

The pedal is operated in the following four steps:

- 1) The machine runs at low sewing speed when you lightly depress the front part of the pedal. **B**
- 2) The machine runs at high sewing speed when you further depress the front part of the pedal. **A**
(If the automatic reverse feed stitching has been preset, the machine runs at high speed after it completes reverse feed stitching.)
- 3) The machine stops (with its needle up or down) when you reset the pedal to its original position. **C**
- 4) The machine trims threads when you fully depress the back part of the pedal. **E**

- * When auto-lifter (AK125) is used, 1-step switch is increased between stop and thread trimming. The presser foot goes up when the back part of the pedal is lightly depressed **D**, and the presser foot comes down once when the back part of the pedal is further strongly depressed. Then the thread trimmer is actuated and the presser foot goes up again.
- If you reset the pedal to its neutral position during the automatic reverse feed stitching at seam start, the machine stops after it completes the reverse feed stitching.
- The machine will perform normal thread trimming even if you depress the back part of the pedal immediately following high or low speed sewing.
- The machine will completely perform thread trimming even if you reset the pedal to its neutral position immediately after the machine started thread trimming action.
- When the auto-lifter (AK125) is not used, and the selection of pedal type of the control box (SC-910) is set to KFL, the pedal depressing amount at the time of thread trimming can be shallowed. For the setting procedure, refer to the Instruction Manual for SC-910.

[When the table/stand for standing work is used]

When using the table/stand for standing work, change the description of the function setting No. 117 from "0" to 1 since the presser is lifted by means of the presser lifting pedal. In this case, the simplified teaching function cannot be used for LH-4168-7, 4188-7.

5-2. Hand lifter

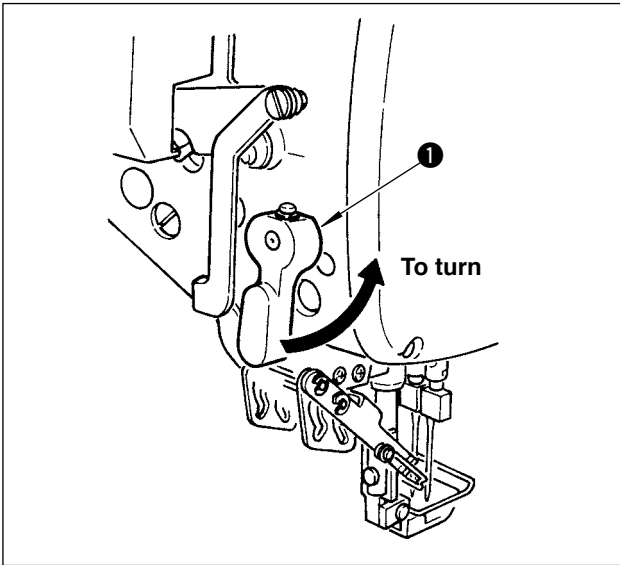

- 1) When you want to keep the presser foot in the lifted position, turn hand lifter ① in the direction of the arrow. By so doing, the presser foot rise 5.5 mm.
- 2) When you want to lower the presser foot, lower the hand lifter. This will return the presser foot to its predetermined lower position.
- 3) Operate the knee lifter, and the presser will rise by approximately 12 mm.



Do not perform thread trimming operation with the presser foot lifted since there is a case where the wiper comes in contact with the presser foot.

5-3. Adjusting the pressure of the presser foot

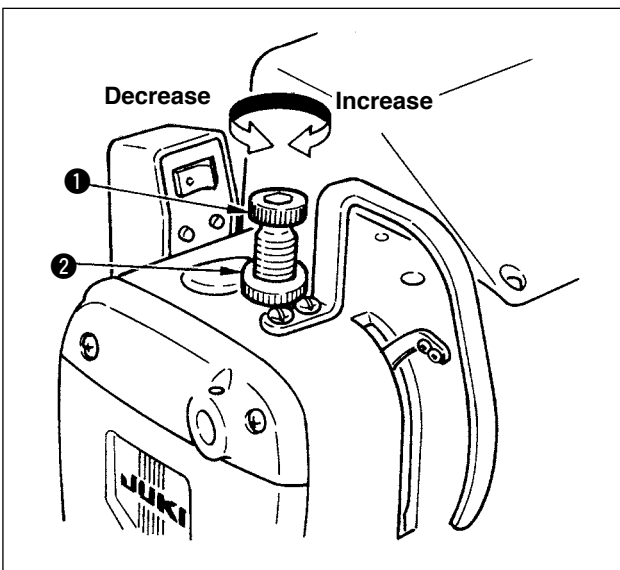

Loosen nut ② by turning counterclockwise, and turn presser spring regulator ① to adjust the pressure. Turn the regulator clockwise to increase the pressure and turn it counterclockwise to decrease the pressure.
After the adjustment, tighten nut ②.

5-4. Thread tension release changeover when using the knee lifter

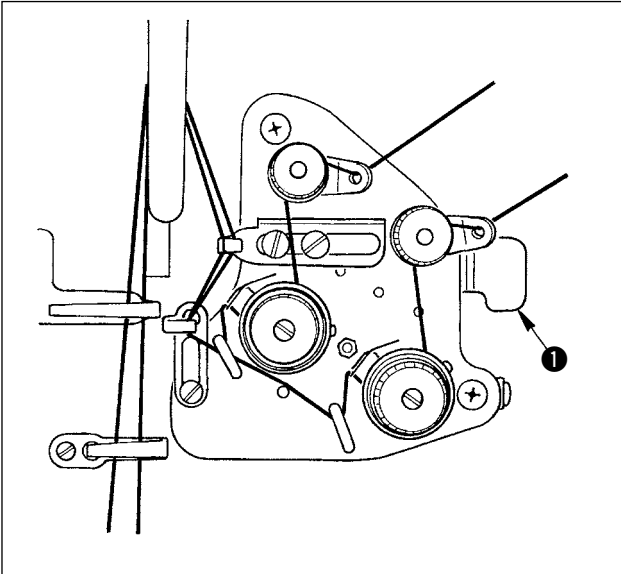

For LH-4128-7, LH-4168-7, LH-4188-7 the knee lifter or AK device is not interlocked with the thread tension release of thread tension controller at the time of delivery. When releasing the thread tension, press lever ❶ to rise the disks.

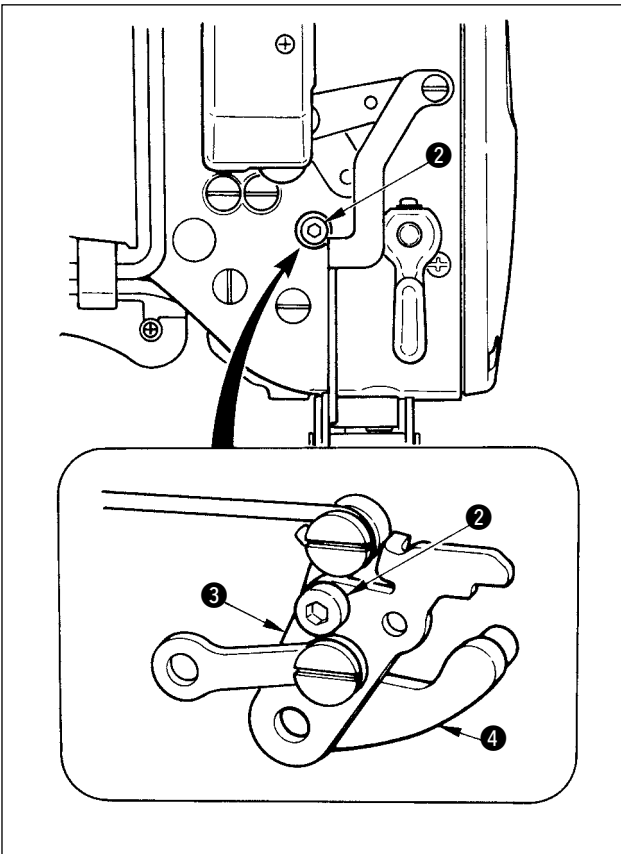

When interlocking the thread tension release
Remove the cap at the back, pass screw ❷
supplied as accessories through the hole in
presser lifter plate ❸, and fix it to presser lifter
lever A ❹.

When interlocking the thread tension release :



1. Thread slacks when turning cloth at the corner stitching, and sewing trouble of thread tension release may occur .
2. When the wiper is not used at the time of thread trimming, needle thread may be drawn out when removing cloth.

5-5. Separately driven needle changeover switch (for LH-4168-7 and 4188-7)

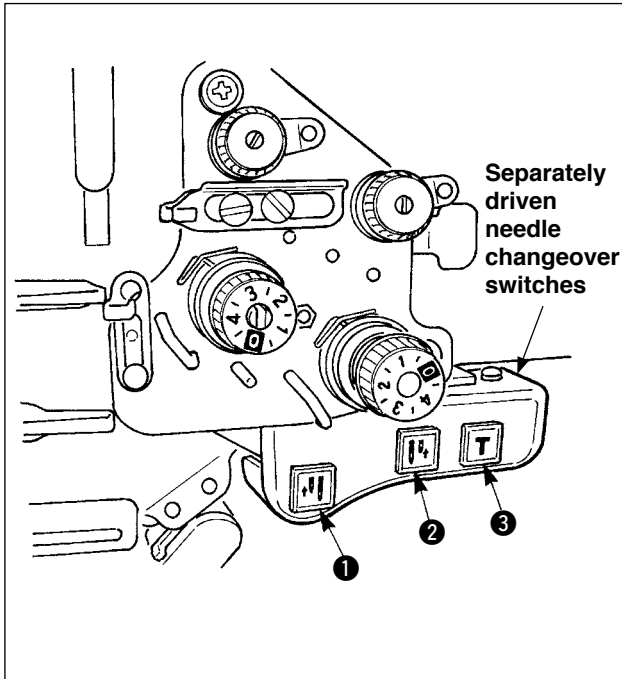

- ① Left-hand needle changeover switch
When this switch is pressed, left-hand needle goes up. When it is pressed again, the needle comes down.
- ② Right-hand needle changeover switch
When this switch is pressed, right-hand needle goes up. When it is pressed again, the needle comes down.
- ③ Teaching switch

When ① or ② is pressed after pressing ③, or ③ is pressed after pressing ① or ②, number of stitches until the presser foot goes up next from a single needle state is counted. When the presser foot is lowered, the needle returns after sewing the number of stitches which has been counted.

• Changeover of the teaching mode

Changeover of the teaching mode can be performed by the procedures below. Use it properly in accordance with the types of sewing products.

- 1) Pressing the button located in the extreme right side of the control box, turn ON the power switch, and the setting for function can be called.

(Refer to the Instruction Manual for SC-910.)

- 2) Call function setting No. 112 of the display in the control box.

Setting 0 (Initial set value) : Normal mode (manual teaching mode)

When the sewing comes to the corner section, press left-hand (right-hand) needle changeover switch and teaching switch.

Sew the corner in a single needle state, lift the presser foot, turn the cloth, and sew the corner of return.

It is not necessary for the operator to perform the release at the time of return since the release of single needle after this work is automatically performed.

(This function cannot be obtained unless the teaching switch is pressed.)

Setting 1 : Automatic move by changeover of single needle

It is the setting that the teaching mode is automatically set when the separately driven needle changeover switch is pressed.

Without pressing the teaching switch, number of stitches until the presser foot goes up from a single needle state is counted, and when the presser foot is lowered, the needle returns after the number of stitches which has been counted. Number of times of button operation is decreased since the number of stitches of entering and that of return are the same in many cases.

Setting 2 : Teaching mode changeover prohibition

It is the setting that the mode does not become the teaching mode even when the teaching switch is pressed after the separately driven needle changeover switch was pressed and several stitches were sewn.

This function saves the trouble that the stitches of entering and return do not agree with each other when the teaching switch works after several stitches were sewn.

5-6. One-touch reverse feed switch lever (for touch-back)

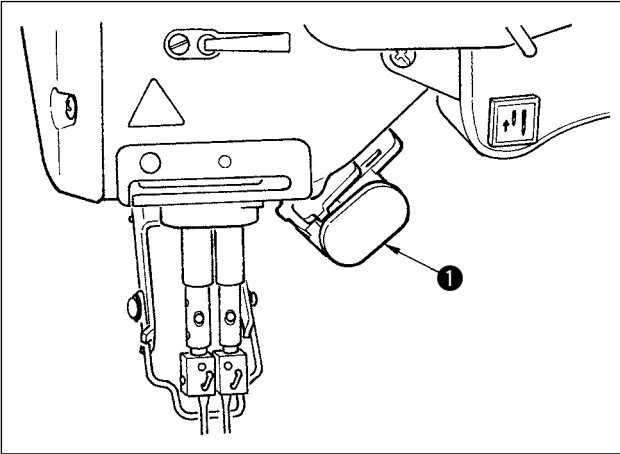

(1) How to use

- 1) Depress switch ❶, and the machine will immediately run in the reverse direction.
- 2) Reverse stitch is made as long as you keep depressing the switch lever.
- 3) Release the switch lever for forward sewing.

6. MAINTENANCE

6-1. Changing procedure to bottom feed and the adjustment (LH-4128 without thread trimmer only)

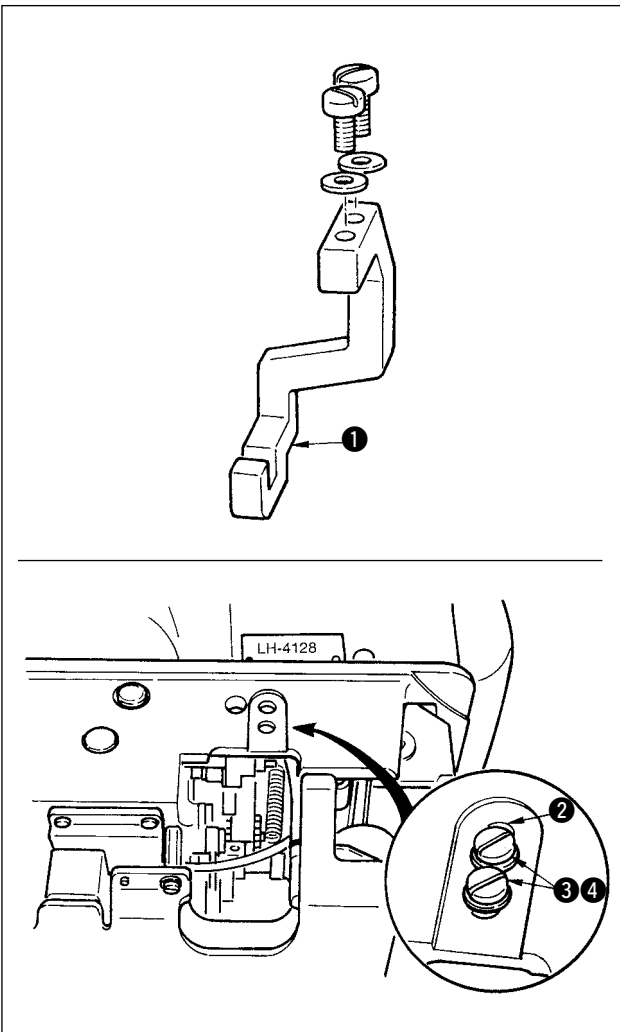

- 1) Prepare the gauge for bottom feed.
Temporarily set needle rocking rod fixing base ❶ contained in the accessories to hole ❷ of the machine frame with washers ❸ and setscrews ❹.

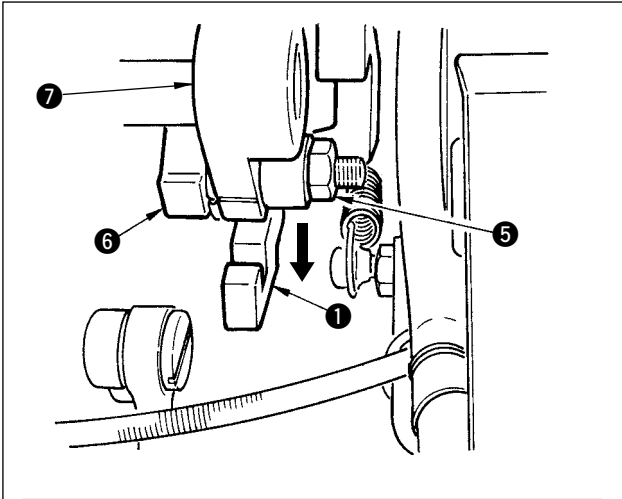

- 2) Loosen nut **5** after adjusting the feed dial to "0", move needle bar rocking rod **6** from needle bar rocking rod arm **7** to needle rocking rod fixing base **1**, and fix it with nut **5**.

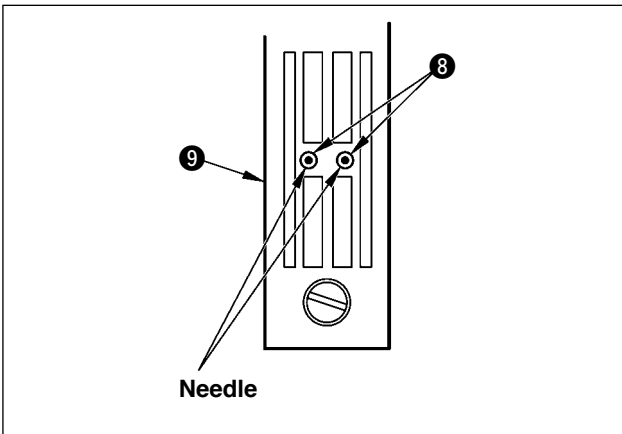
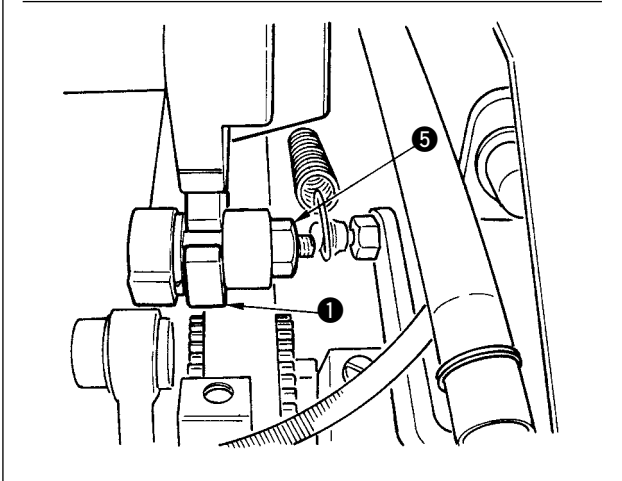

- 3) After replacing the feed dog and the throat plate with the components for bottom feed, adjust the position of needle rocking rod fixing base **1** so that the needle center aligns with needle holes **8** in throat plate **9**, and fix setscrews **4** which have been temporarily set.

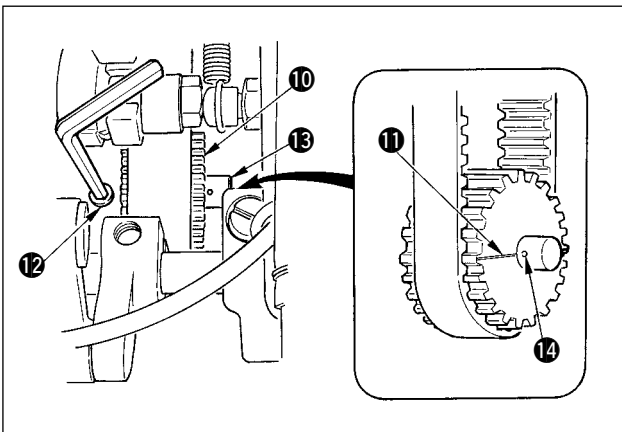

- 4) Loosen setscrews **12** (2 places) in sprocket **10**. At this time, remove the setscrew which is located in the same direction of engraved marker line **11** of the needle bar rocking rod. Turn the pulley by 180° without turning the hook driving shaft **13**, and align engraved marker dot **14** on hook driving shaft **13** with engraved marker line **11**. Put the setscrew which has been removed to the screw hole on the opposite side, and fix with setscrews **12** (2 places).

6-2. Changing procedure to needle feed (for LH-4128 only)

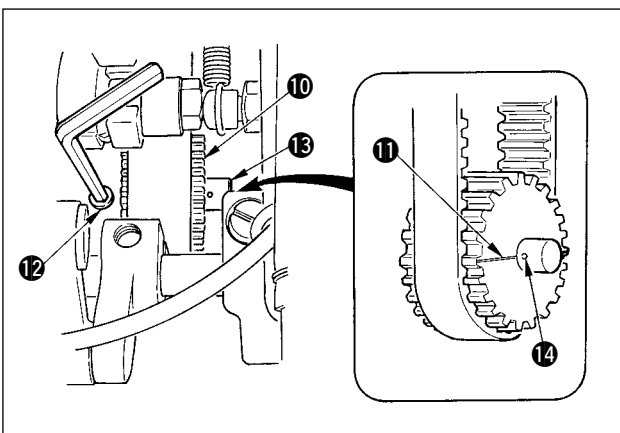
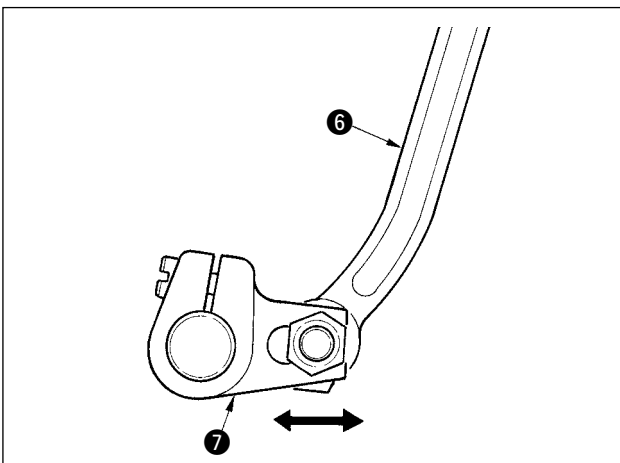
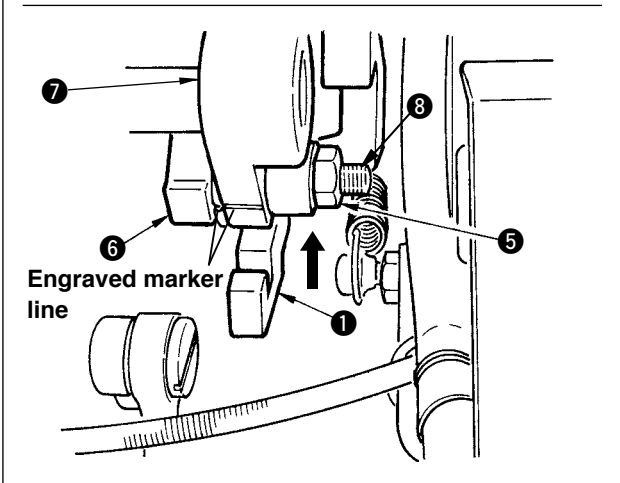
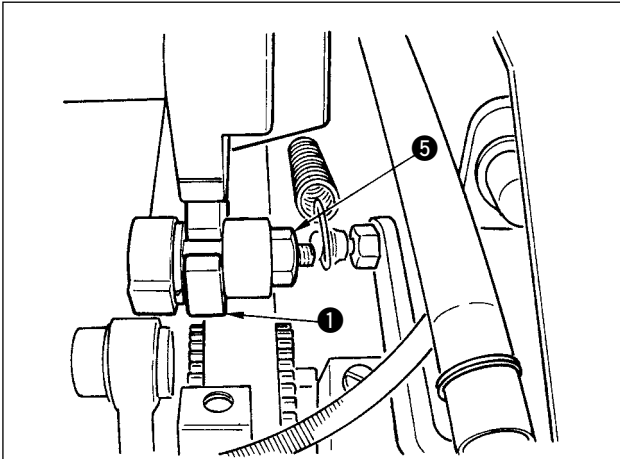

The procedure is the reverse of “6-1. Changing procedure to the bottom feed”.

Loosen nut ⑤, move needle bar rocking rod ⑥ from needle rocking rod fixing base ① to needle bar rocking rod arm ⑦, and temporarily fix it with nut ⑤. At this time, align the engraved marker line of ⑦ with that of ⑧.

Replace the feed dog and the throat plate with the components for needle feed.

Next, adjust so that the needle comes to the center of needle hole of feed dog in both cases of piercing of needle and drawing of needle.

For adjustment, loosen nut ⑤, move needle rocking adjustment screw ⑧ in the direction of the arrow, and securely tighten nut ⑤.

Loosen setscrew ⑫ in sprocket ⑩, turn the pulley by 180°, align engraved marker dot ⑭ on hook driving shaft ⑬ with engraved marker line ⑪, and fix it with setscrew ⑫.



Move the setscrew which is located in the same direction of the engraved marker line to the screw hole on the opposite side.

6-3. Adjusting the inner hook guide



WARNING :

Turn OFF the power switch and ascertain that the motor totally stopped before starting the work so as to prevent personal damage caused by abrupt start of the sewing machine.

LH-4128, 4128-7, 4168-7

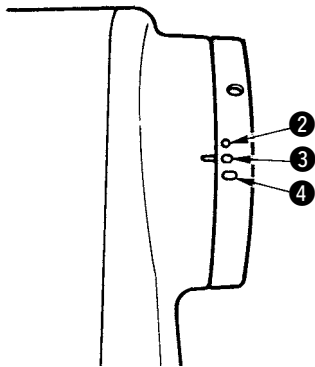
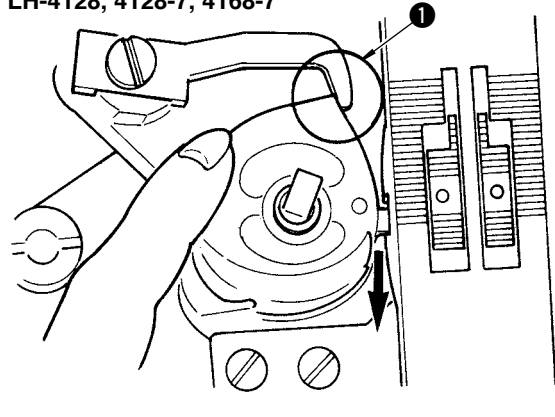

[LH-4128, 4128-7 and 4168-7]

- 1) Standard adjustment value of the opening of the inner hook stopper is 0.3 mm. Adjust the handwheel to engraved markers ③ in the center of three engraved markers, make the inner hook guide ① come in contact with the inner hook while pressing the click of inner hook in the direction of the arrow to fix the inner hook guide.

When the inner hook guide ① is fixed at the position of small engraved marker ②, the opening of the inner hook stopper is decreased, and when it is fixed at the position of large engraved marker ④, the opening of the inner hook stopper is increased.

LH-4188-7

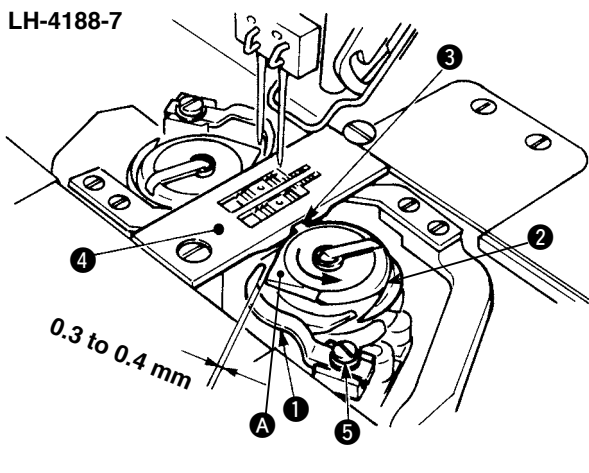

[LH-4188-7]

- 1) Turn the handwheel in the normal direction until inner hook guide ① has entirely withdrawn from its working position.
- 2) Turn bobbin case ② in the direction of arrow mark until inner hook stopper ③ rests in the groove on throat plate ④.
- 3) Loosen setscrew ⑤ in the inner hook guide and provide a clearance of 0.3 to 0.4 mm between the inner hook guide and protrusion ① on the bobbin case.

6-4. Needle-to-hook relation

[LH-4168-7, 4188-7]

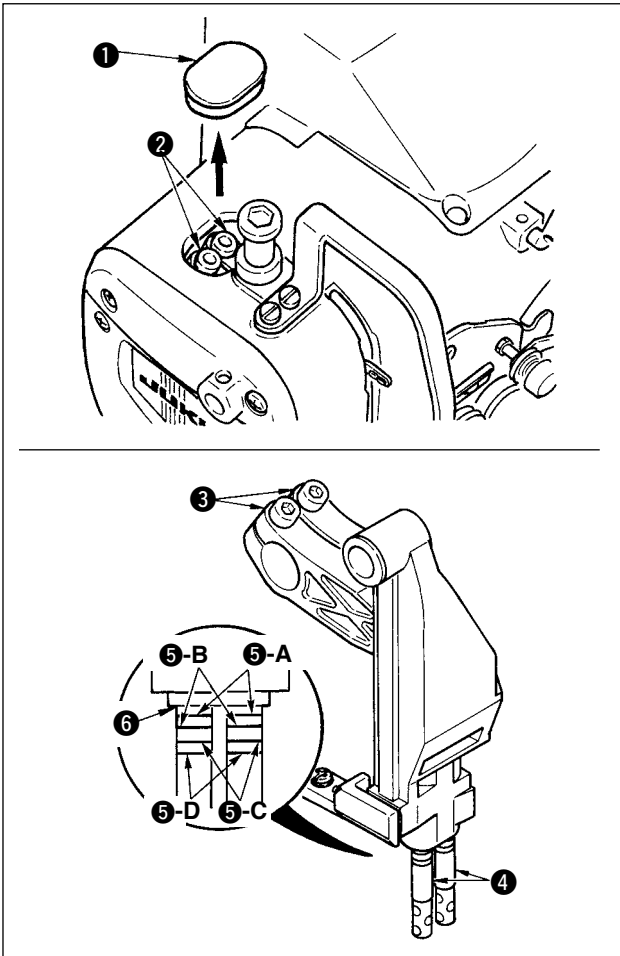

- 1) Determine the height of needle.
1. Set the stitch dial to 2.5 on the scale.
2. Turn the handwheel to bring the needle bar to the lowest position.
3. Remove cap ①, loosen setscrews ② in needle drive arms ③, adjust engraved marker lines ⑤-A which are the fourth from the bottom of needle bars ④ to the bottom end of needle bar lower bushing ⑥, and tighten needle drive arms ③ with screw tightening torque of 5.9 Nm (60 kgf · cm) using setscrews ②.
4. Turn the handwheel and adjust engraved marker lines ⑤-B which are the third from the bottom of the needle bar to the bottom of needle bar lower bushing ⑥. (2.2 mm up) At this time, it is the standard that the distance from the top end of the needle eyelet to the blade point of the hook is 1.2 mm.



- The aforementioned adjustment is applied to the case when DPX5 needle is used. When using DPX17 needle, adjust with ⑤-C and ⑤-D respectively.
- When loosening/tightening setscrew ②, perform the work so that needle drive arm ③ does not move in the lateral direction. When it moves, needle bar torque or needle bar seizure will be caused.

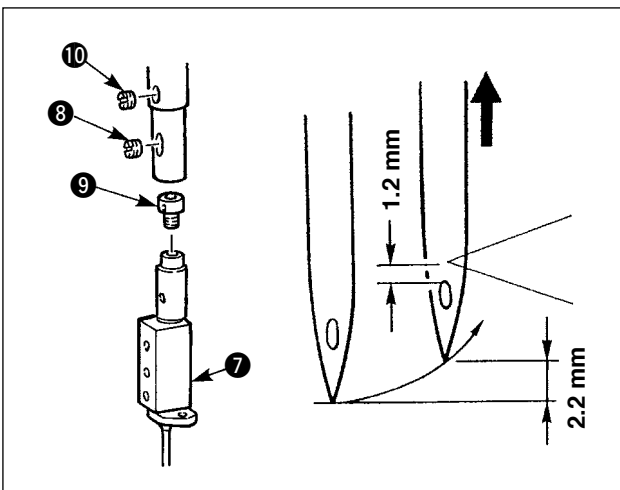

5. If the needle-to-hook relation is different from the aforementioned standard adjustment, remove needle clamp screw ⑧ and turn needle clamp ⑦ by one revolution (the extent of adjustment : 0.6 mm). The needle-to-hook relation can also be adjusted by removing screw ⑩ from the spring shoe and turning spring shoe ⑨ by a half revolution (the extent of adjustment : 0.3 mm).

[Reference dimension] Needle clamp height at needle bar lower dead point

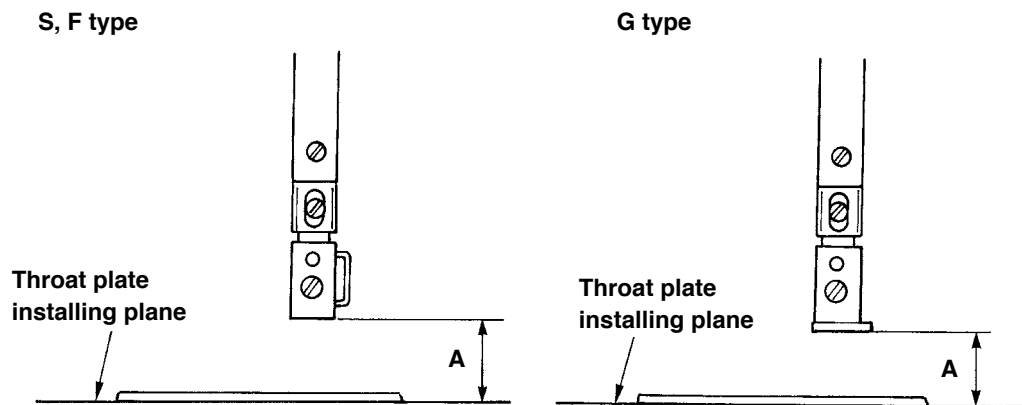

	LH-4128, 4128-7	LH-4168-7 S type	LH-4168-7 G type	LH-4188-7
Dimension A	15.1 ± 0.15 mm	15.8 ± 0.15 mm	14.6 ± 0.15 mm	15.2 ± 0.15 mm

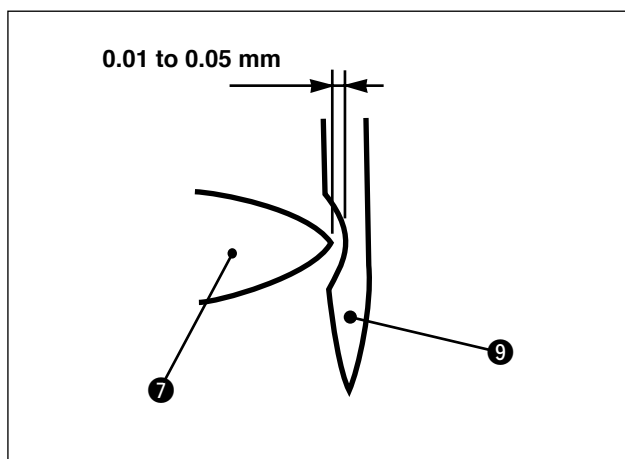
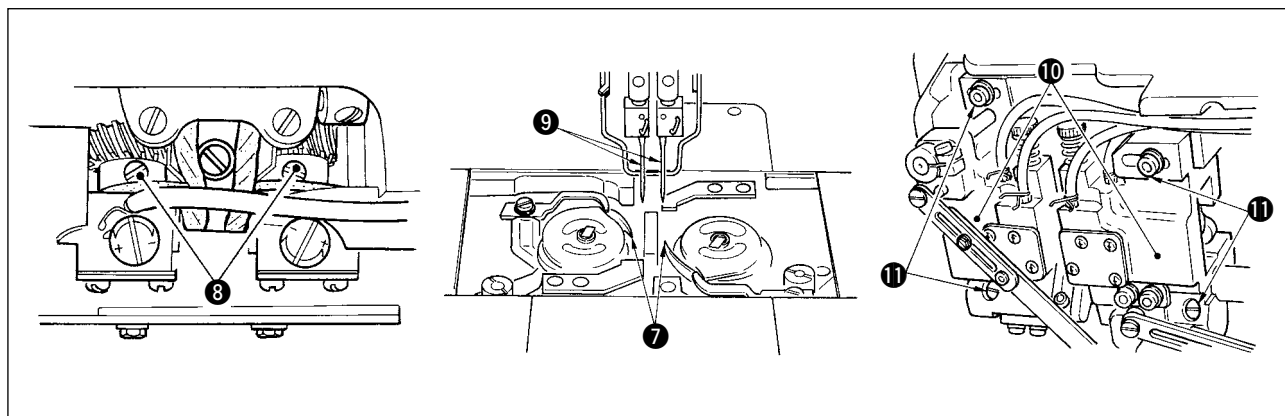

- 2) Determine the position of the hook.
 1. Loosen three setscrews 8 in the screw gear (small).
 2. In this state, loosen four setscrews 11 in hook driving shaft saddle 10, and move hook driving shaft saddle 10 to the right or left to adjust so that a clearance of 0.01 to 0.05 mm is provided between blade point 7 of the hook and needle 9. Then tighten setscrews 11.
 3. In the state described in step 1)-4., align blade point 7 of the hook with the center of the needle and tighten setscrews 8 in the screw gear (small).

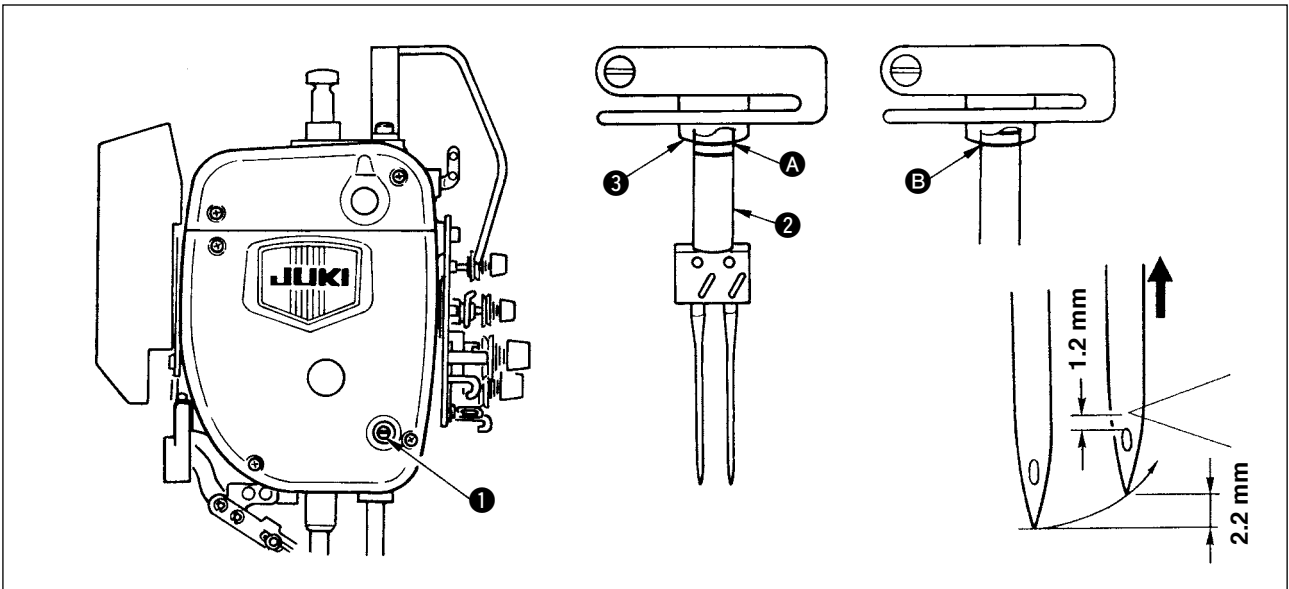

- 1) Determine the needle bar height.
 1. Set the stitch dial to 2.5 on the scale.
 2. Turn the handwheel to bring the needle bar to the lowest position. Then, loosen needle bar connecting stud clamping screw ①.
 3. Adjust engraved marker line A which is the second from the bottom of needle bar ② to the bottom end of needle bar rocking base ③, and tighten the needle bar connecting stud clamping screw.
 4. Turn the handwheel and adjust lower engraved marker line B of the needle bar to the bottom end of the needle bar rocking base. (2.2 mm up) At this time, the distance from the top end of the needle eyelet to the blade point of the hook becomes 1.2 mm.

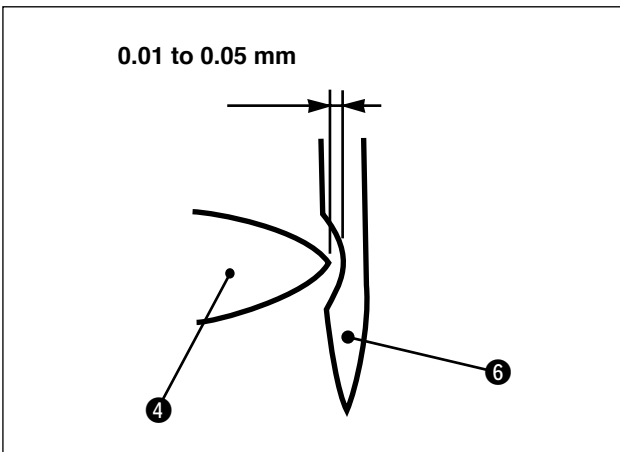

- 2) Determine the position of the hook.
 1. Loosen three setscrews ⑤ in the screw gear (small).
 2. In this state, loosen four setscrews ⑧ in hook driving shaft saddle ⑦, and move hook driving shaft saddle ⑦ to the right or left to adjust so that a clearance of 0.01 to 0.05 mm is provided between blade point ④ of the hook and needle ⑥. Then tighten setscrews ⑧.
 3. In the state described in step 1)-4.), align blade point ④ of the hook with the center of the needle and tighten setscrews ⑤ in the screw gear (small).

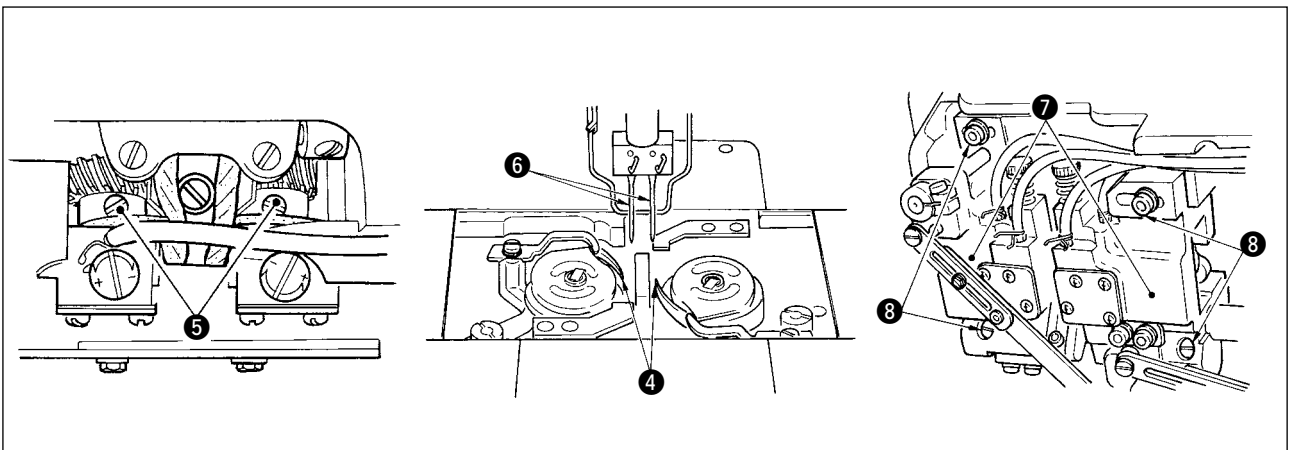

6-5. Adjusting the height and the inclination of the feed dog

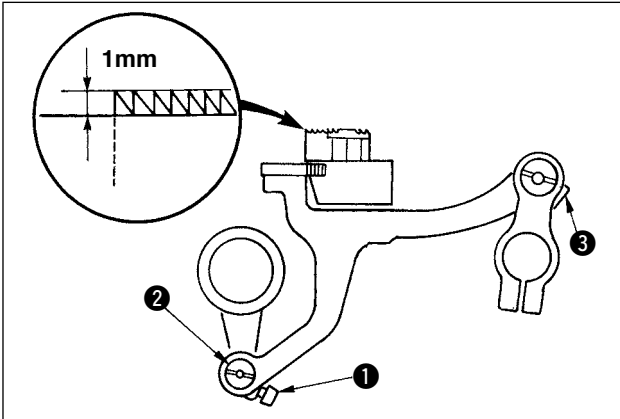

(1) Adjusting the height

- 1) Loosen bottom feed link setscrew **1**, and turn feed driving link shaft **2** to adjust the height. Standard height is 1 mm from the throat plate in the highest position.

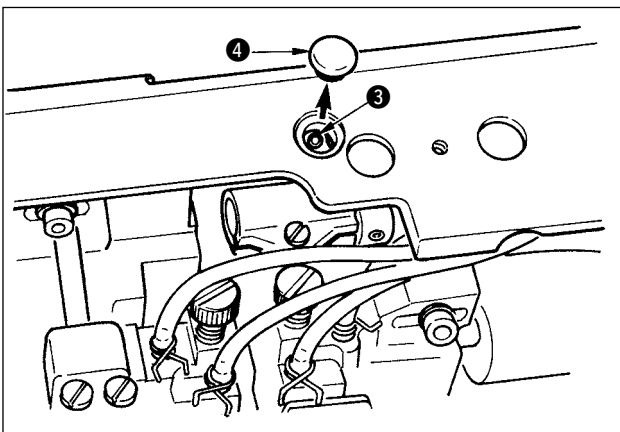

(2) Inclination

- 1) Remove cap **4** on the side of machine bed, loosen feed bar shaft setscrew **3**, and turn knurled section **5** to adjust the inclination. Standard adjustment is as follows :
 - LH-4128, 4128-7, 4168-7 : Position where engraved marker dot **C** of feed bar arm aligns with engraved marker dot **B** of feed bar shaft. (Engraved marker dot **A** is for LH-3500.)
 - LH-4188-7 : Engraved marker line is level.

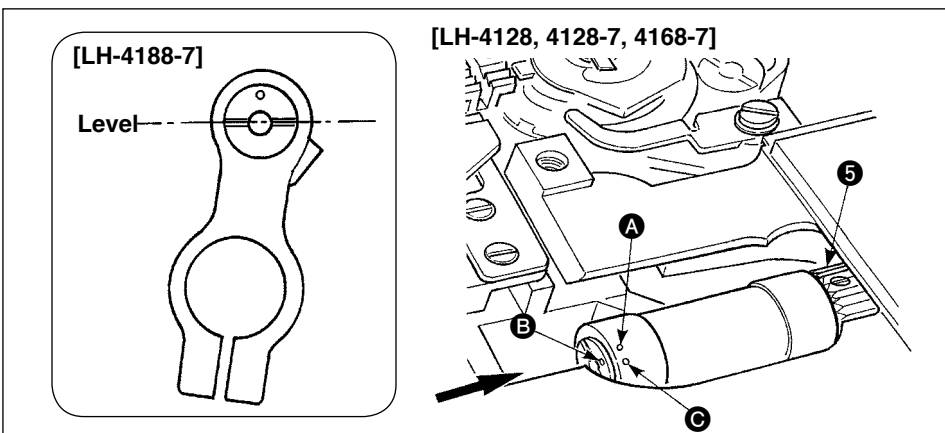

6-6. Adjusting the presser foot

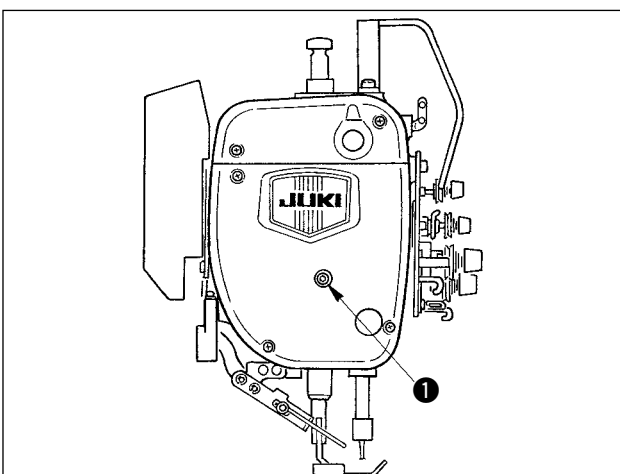

Confirm the grounding when replacing the presser foot.

- 1) When changing the height or the angle at the time of replacing the presser foot, loosen needle bar connecting stud clamping screw **1** to adjust it. (Make sure of the clearance between the hole of the presser foot and the needle and that between the presser foot and the throat plate.)
- 2) After the adjustment, securely tighten the screw **1**.

6-7. Move (adjustment) of the hook shaft saddle when replacing the gauge

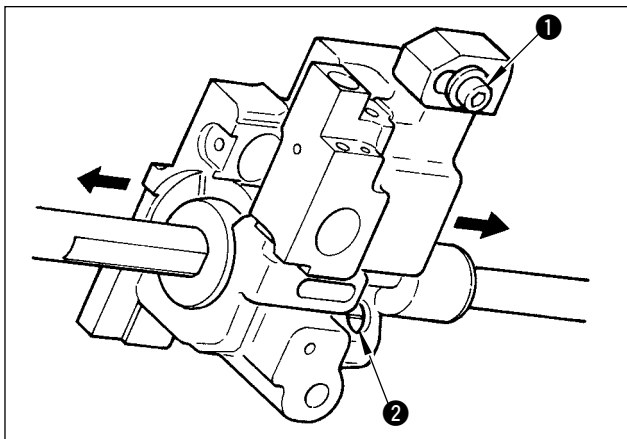

Move of the hook shaft saddle when replacing the gauge can be performed with ease by only loosening screws ① and ②.

It is not necessary to re-adjust the hook timing.

6-8. Adjusting the thread presser spring

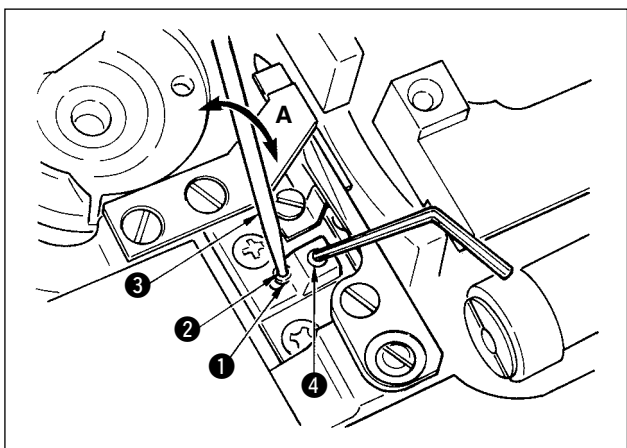

Insert a rod (thin rod, wrench, etc.) into adjusting hole ② in thread presser spring base ①, and loosen setscrew ④ with a hexagonal wrench key of 1.5 mm.

Adjust the thread presser spring by moving rod ③ in the direction of arrow mark A, and fix it with setscrew ④.



Clamp trouble occurs even when the thread presser spring pressure is excessive or insufficient. So, be careful.

6-9. Adjusting the position of the moving knife

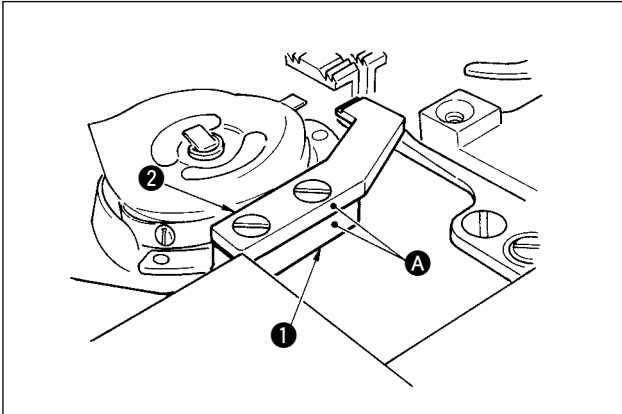

- 1) Align counter knife base **1** with plane **A** of counter knife **2**.

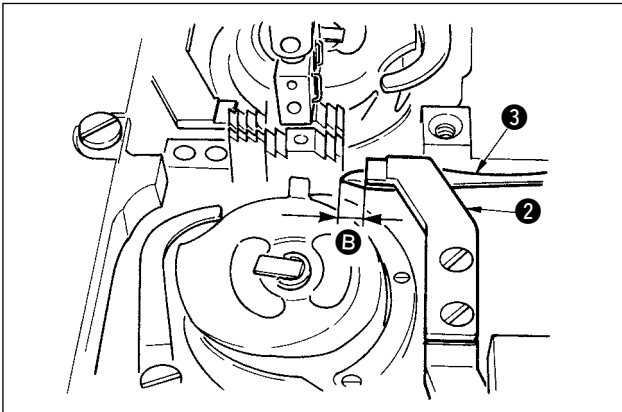

- 2) Loosen clamp screw **3** located in the rear of machine bed and adjust so that distance **B** between the top end of moving knife **B** at the time of waiting and the top end of counter knife **4** is dimension B.

Dimension B	}	4128-7	3.1 ± 0.2 mm
		4168-7	3.3 ± 0.2 mm
		4188-7	3.3 ± 0.2 mm

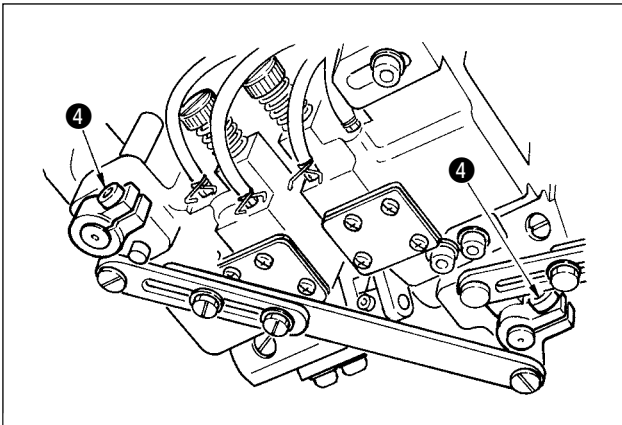

- 3) Set clearance **C** between moving knife **3** and the inner hook to 0.4 ± 0.1 mm when moving knife **3** works. Loosen moving knife setscrews **6** and **7** and adjust the clearance.

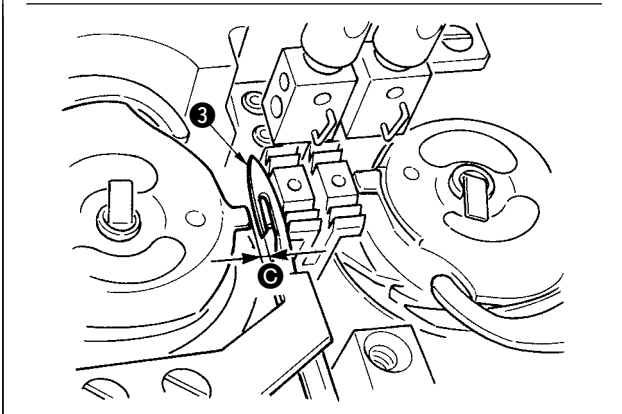

6-10. Replacing the bobbin thread slack preventer spring (for LH-4168-7 and 4188-7)

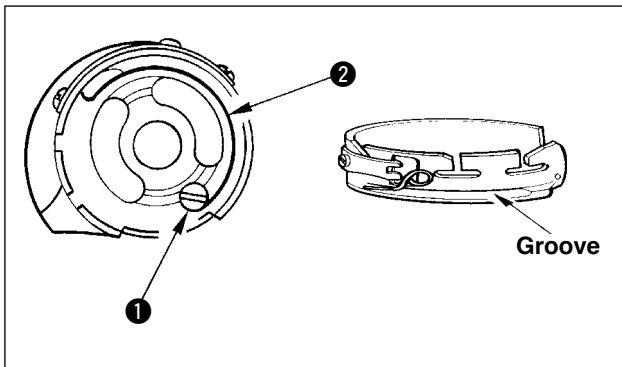

- 1) Loosen screw ① and remove bobbin thread slack preventer spring ② from the groove on the bobbin case.
- 2) Fit bobbin thread slack preventer spring ② which replaces the removed spring in the bobbin case through the groove.
- 3) Fix bobbin thread slack preventer spring ② in the bobbin case by tighten screw ①. At this time, carefully check the operating range and tension of the spring.

6-11. Adjusting the hook needle guard



WARNING :

Turn OFF the power switch and ascertain that the motor totally stopped before starting the work so as to prevent personal damage caused by abrupt start of the sewing machine.

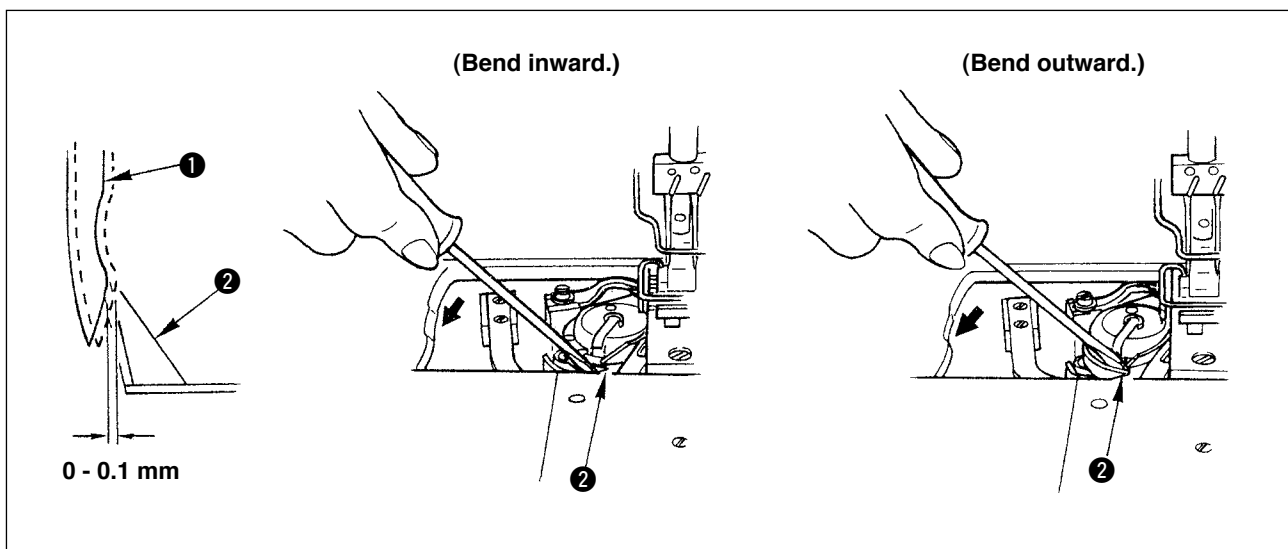

When replacing the hook, confirm the position of the needle guard.

The standard position is the state that hook needle guard ② comes in contact with the side of needle ① and the needle is along the hook needle guard by 0 to 0.1 mm. If not, adjust by bending the hook needle guard.

- 1) When bending the hook needle guard inward, perform by entering a screwdriver to the outside of the hook needle guard.
- 2) When bending the hook needle guard outward, perform by entering a screwdriver to the inside of the hook needle guard.

6-12. Stop of the needle bars and angle of corners for corners stitching (for LH-4168-7 and 4188-7)

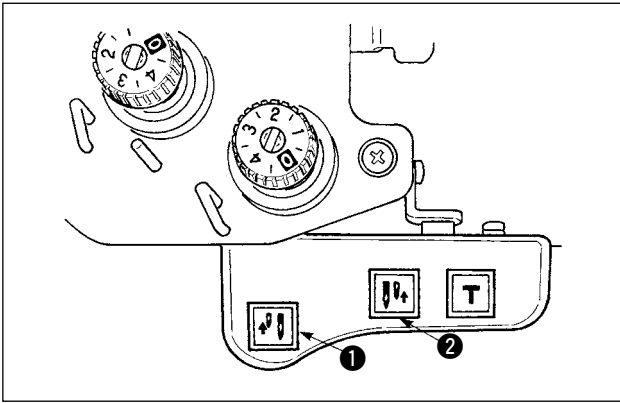

(1) Stop of the needle bars

When separately driven needle changeover switch ① is pressed during sewing, the left-hand needle bar stops, and when ② is pressed, the right-hand needle bar stops. When the sewing machine is being operated at high speed, the speed is automatically reduced and the needle bar is stopped. When separately driven needle changeover switches ① and ② are pressed again, the machine returns to 2-needle sewing machine. The lamp of switch becomes as described below in accordance with the state of separately driven needle changeover.

At the time of needle driving : Light goes off.

At the time of waiting separately driven needle changeover : Light flashes on and off.

At the time of needle stop : Light is turned on.

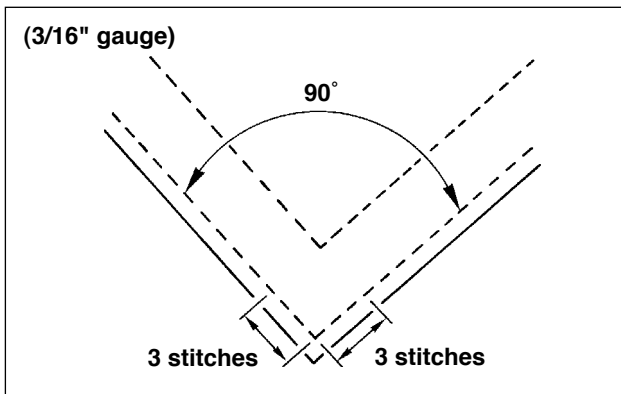

(2) Relation between the angle of corners and stitch length

To perform corner stitching with accuracy, the stitch length can be determined referring to the table of the number of stitches by gauges. However, check whether the stitch length determined really matches the corner by actually sewing it.

(Example) To sew a corner of 90° of angle using a 3/16" gauge with the stitch length specified to 1.6mm, the number of stitches can be obtained in the following way. Observe the "90°" columns on the table of the number of stitches by stitch length gauges to search for the column in which "1.6" is indicated. Then, you can find "3" on the top of the "1.6" lines. This means the number of stitches is 3.



If sewing a corner of which angle is 40° or less, the thread take-up amount of the bobbin thread slack preventer spring will be insufficient. In this case, the thread will remain on the wrong side of the material.

6-13. Caution when installing the gauge to the bed slide

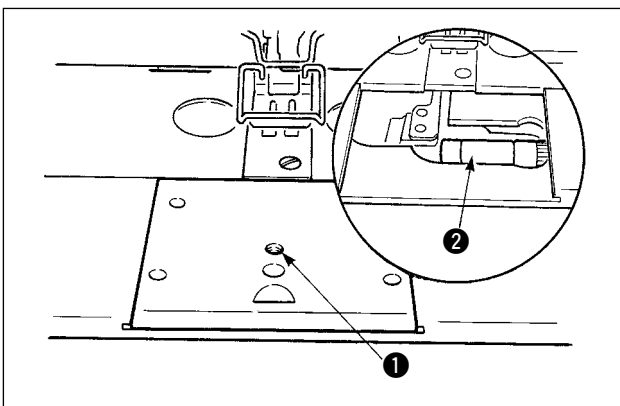

When installing the gauge using the screw hole ① in the center of the bed slide, select the length of the screw so that the top end of the screw does not come in contact with the feed bar shaft ② located under the bed slide.



When the top end of the screw interferes with the feed bar shaft, feed pitch becomes uneven, or the machine is locked. So, be careful.

6-14. Position of the wiper



WARNING :

Turn OFF the power switch and ascertain that the motor totally stopped before starting the work so as to prevent personal damage caused by abrupt start of the sewing machine.

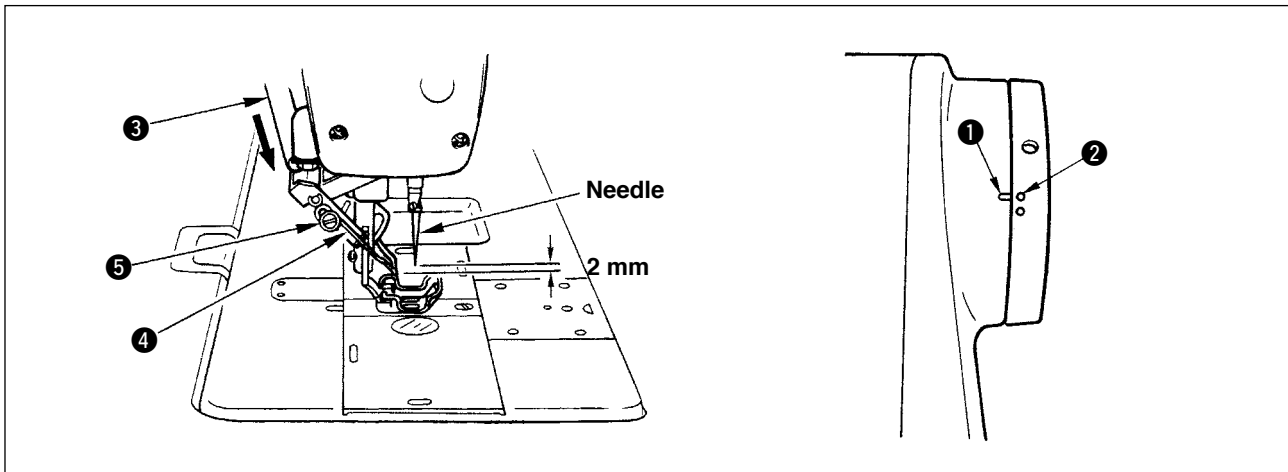

- 1) Adjust engraved marker dot ❶ on the machine arm to white engraved marker dot ❷ on the handwheel (second white engraved marker dot in the rotating direction of the sewing machine).
- 2) Move rod ❸ in the direction of the arrow, and adjust with two clamping screws ❺ so that the clearance between the top end of needle and wiper ❹ is approximately 2 mm.

6-15. Replenishing grease to the specified places (for LH-4168-7 and 4188-7)

When the sewing machine is used for a certain number of times of sewing (number of stitches), error code No. E220 is displayed on the control box when the power is turned ON (it is displayed on IP panel as well when using IP panels such as IP-100, IP-110, etc.), and further the warning buzzer sounds 5 times intermittently. This warning is to inform you of the replenishing time of grease to the specified places. Be sure to replenish grease, call memory switch No. 118, set the description to “1”, and turn OFF the power.

Although the machine can be used continuously even after the display of error No. E220, error No. E220 is displayed every time the power is turned ON and the warning buzzer sounds. Press RESET key when using IP panel and the error is released.

In addition, when the sewing machine is used for a certain period of time after the display of error No. E220, error No. E221 is displayed, and the sewing machine fails to operate. Error cannot be released even when RESET key is pressed when using IP panel.

If error No. E221 is displayed, be sure to replenish grease to the specified place below, call memory switch No. 118, set the description to “1”, and turn OFF the power.



1. After replenishing grease, call memory switch No. 118, set the description to “1”, and turn OFF the power. Otherwise, error No. E220 or error No. E221 is displayed again.
2. For replenishing grease to the specified places below, use JUKI GREASE A TUBE (Part No. 40006323) or JUKI GREASE B TUBE (Part No. 40013640) supplied as accessories. If grease other than the specified one is used, breakage of components will be caused.

**WARNING :**

Turn OFF the power before starting the work so as to prevent accidents caused by abrupt start of the sewing machine.

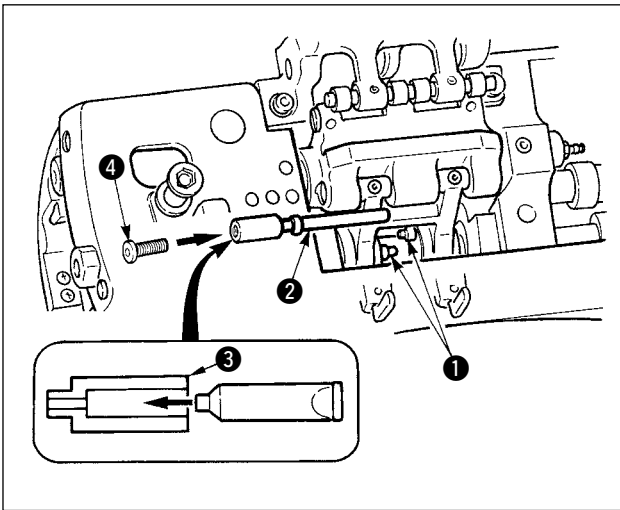
(1) Replenishing grease to the needle bar drive cam section

- 1) Remove the top face cover, and remove the rubber caps attached to the nipples ①.
- 2) Fill joint ③ supplied as accessories with grease A from the grease tube.
- 3) Connect pipe ② with nipples ①, turn screw ④ supplied as accessories to joint ③, and replenish the joint with grease.



Replenish the joint with grease by repeating grease filling of step 2) when the first replenishing is not enough.

- 4) Fit the rubber caps to the nipples, turn the main shaft by hand, and confirm that the rubber caps do not interfere with other components. When turning the main shaft with the rubber caps removed, the rubber caps are torn off. Be sure to turn the main shaft after fitting the rubber caps to the nipples.

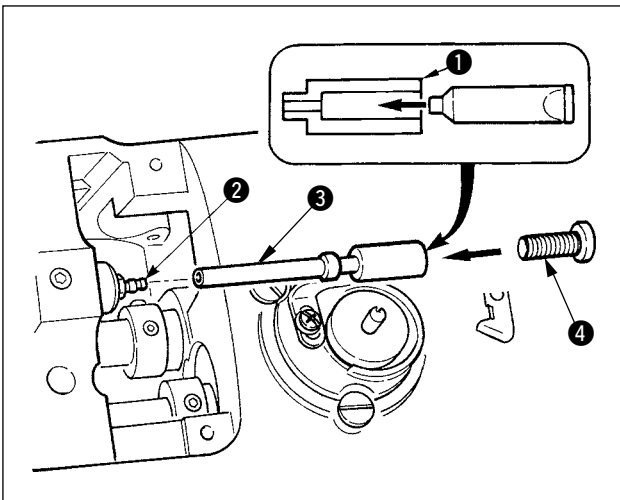
(2) Center link section

- 1) Remove the rubber cap located at the top surface of face section and the face plate.
- 2) Fill joint ① supplied as accessories with grease B from the grease tube.
- 3) Connect pipe ③ with nipple, right ②, turn screw ④ supplied as accessories to joint ①, and fill the joint with grease.



Replenish the joint with grease by repeating grease filling of step 2) when the first replenishing is not enough.

- 4) With the same procedure as steps 2) and 3), fill nipple, left ⑤ with grease B. At this time, pass the pipe through the rubber cap hole located at the top surface of the face section, and connect it with nipple, left ⑤.
- 5) Return the face plate, rubber cap, and top face cover to their home places.

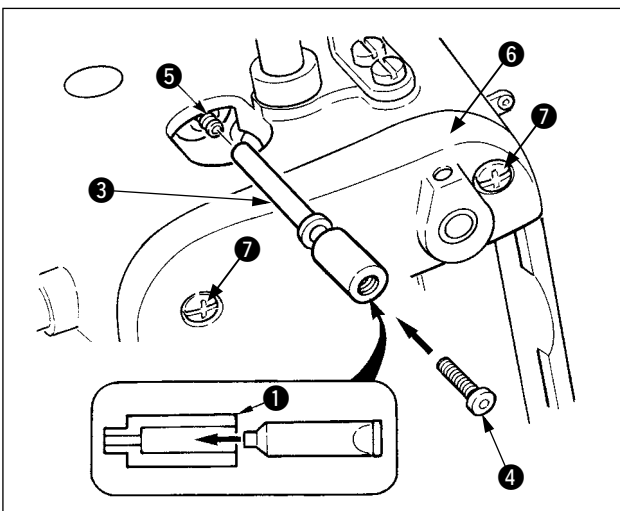

- To confirm the amount of replenishing at all grease replenishing sections is performed by confirming that grease protrudes from the corresponding sections.
- Do not loosen setscrews ⑦ in fulcrum shaft base ⑥. If it is removed once, seizure of sewing machine torque will be caused.

6-16. Cleaning the inside of the needle bar bushing



WARNING :

Turn OFF the power before starting the work so as to prevent accidents caused by abrupt start of the sewing machine.

[LH-4168-7, LH-4188-7]

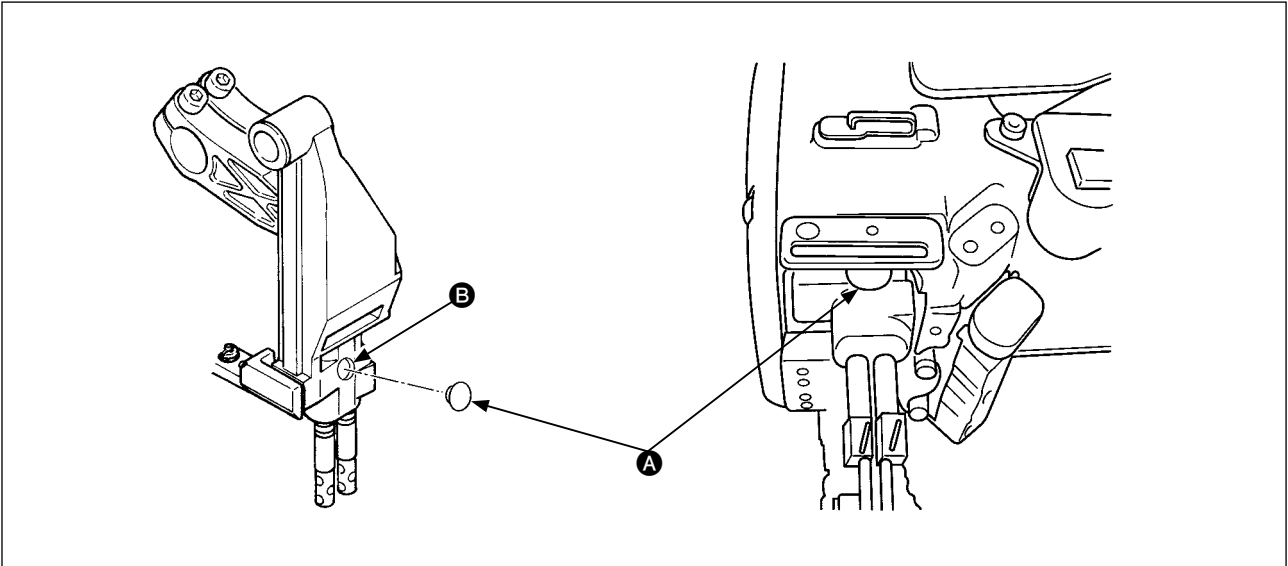

Inside of the needle bar bushing should be cleaned once every six months.

- 1) Tilt the sewing machine.
- 2) Remove cap **A**.
- 3) Remove thread waste and dust through hole **B** in the needle bar frame.



At this time, be careful not to damage the needle bar. If the needle bar is damaged, wear of the needle bar can result.

- 4) Fill the hole with grease A.
- 5) Fit the cap back to its place.

* **If thread waste and dust accumulates inside the needle bar bushing, a needle changeover error may result.**

7. STITCH-TO-ANGLE TABLE BY GAUGE (PITCH AND mm CONVERSION TABLE)

1/8"(3.17mm)

Turning angle \ Number of stitches	1	2	3	4	5	6	7	8	9
40		4.4	2.9	2.2	1.7	1.5			
50		3.4	2.3	1.7					
60		2.7	1.8						
70	4.5	2.3	1.5						
80	3.8	1.9							
90	3.2	1.6							
100	2.6								

5/32"(3.96mm)

Turning angle \ Number of stitches	1	2	3	4	5	6	7	8	9
40			3.6	2.7	2.2	1.8	1.6		
50		4.2	2.8	2.1	1.7				
60		3.4	2.3	1.7					
70		2.8	1.9						
80	4.7	2.4	1.6						
90	4.0	2.0							
100	3.3	1.7							

3/16"(4.76mm)

Turning angle \ Number of stitches	1	2	3	4	5	6	7	8	9
40				3.3	2.6	2.2	1.9	1.6	1.5
50			3.4	2.6	2.0	1.7	1.5		
60			2.7	2.1	1.6	1.4			
70		3.4	2.3	1.7	1.4				
80		2.8	1.9	1.4					
90	4.8	2.4	1.6						
100	4.0	2.0							

7/32"(5.56mm)

Turning angle \ Number of stitches	1	2	3	4	5	6	7	8	9
40			5.1	3.8	3.1	2.5	2.2	1.9	1.7
50			4.0	3.0	2.4	2.0	1.7	1.5	
60		4.8	3.2	2.4	1.9	1.6			
70		4.6	2.6	2.0	1.6				
80		3.3	2.2	1.7					
90	5.6	2.8	1.9	1.4					
100	4.7	2.3	1.6						

1/4"(6.35mm)

Turning angle \ Number of stitches	1	2	3	4	5	6	7	8	9
40				4.4	3.5	2.9	2.5	2.2	2.0
50			4.6	3.4	2.8	2.3	2.0	1.7	1.6
60			3.7	2.8	2.2	1.9	1.6		
70		4.6	3.1	2.3	1.9	1.6			
80		3.8	2.6	1.9	1.6				
90		3.2	2.2	1.6					
100		2.7	1.8						

9/32"(7.14mm)

Turning angle \ Number of stitches	1	2	3	4	5	6	7	8	9
40				4.9	3.9	3.3	2.8	2.5	2.2
50			5.1	3.8	3.1	2.6	2.2	1.9	1.7
60			4.1	3.1	2.5	2.1	1.8	1.5	
70		5.1	3.4	2.5	2.0	1.7	1.5		
80		4.3	2.8	2.1	1.7	1.4			
90		3.6	2.4	1.8	1.4				
100		3.0	2.0	1.5					

5/16"(7.93mm)

Turning angle \ Number of stitches	1	2	3	4	5	6	7	8	9
40					4.4	3.7	3.2	2.8	2.5
50				4.3	3.4	2.9	2.5	2.2	1.9
60			4.6	3.5	2.8	2.3	2.0	1.8	1.6
70			3.8	2.9	2.3	1.9	1.7	1.5	
80		4.8	3.2	2.4	1.9	1.6			
90		4.0	2.7	2.0	1.6				
100		3.4	2.3	1.7					

3/8"(9.52mm)







Turning angle \ Number of stitches	1	2	3	4	5	6	7	8	9
40						4.4	3.7	3.3	2.9
50					4.1	3.4	2.9	2.6	2.3
60				4.1	3.3	2.7	2.4	2.1	1.8
70			4.5	3.4	2.7	2.3	1.9	1.7	
80			3.8	2.8	2.3	1.9	1.6		
90		4.8	3.2	2.4	1.9	1.6			
100		4.0	2.7	2.0	1.6				

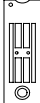

1/2"(12.7mm)

Turning angle \ Number of stitches	1	2	3	4	5	6	7	8	9
40						5.8	5.0	4.4	3.9
50					5.5	4.5	3.9	3.4	3.0
60				5.5	4.4	3.7	3.1	2.8	2.4
70				4.5	3.6	3.0	2.6	2.3	2.0
80			5.1	3.8	3.1	2.5	2.2	1.9	1.7
90			4.2	3.2	2.5	2.1	1.8	1.6	1.4
100		5.3	3.6	2.7	2.1	1.8	1.5	1.3	

8. GAUGE SETS

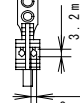
(1) LH-4128

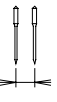
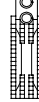
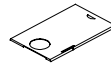
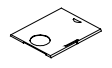
Needle gauge			Throat plate (Throat feed)		Throat plate (Lower feed)				Feed dog					
Cord														
	inch	mm	Ref.No.	Part No.	Ref.No.	Part No.	Ref.No.	Part No.	Ref.No.	Part No.	Ref.No.	Part No.	Ref.No.	Part No.
B	1/8	3.2	1	226-25107	19	228-45200					27	400-33563		
C	5/32	4.0	2	226-25206					78	226-30206	28	400-25784		
D	3/16	4.8	3	226-25305	20	228-45408			79	226-30404	29	400-25785	45	400-25801
E	7/32	5.6	4	226-25404					80	226-30503	30	400-25786	46	400-25802
F	1/4	6.4	5	226-25503	21	228-45606			81	226-30602	31	400-25787	47	400-25803
G	9/32	7.1	6	226-25602					82	226-30800	32	400-25788	48	400-25804
H	5/16	7.9	7	226-25701	22	228-45804			83	226-30909	33	400-25789	49	400-25805
K	3/8	9.5	8	226-25800					84	226-31006	34	400-25790	50	400-25806
W	7/16	11.1	9	226-25909					85	226-31105	35	400-25791	51	400-25807
L	1/2	12.7	10	226-26006			23	400-62254	86	226-31303	36	400-25792	52	400-25808
M	5/8	15.9	11	226-26105					87	226-31402	37	400-25793	53	400-25809
N	3/4	19.1	12	226-26204			24	400-62256	88	226-31501	38	400-25794	54	400-25810
P	7/8	22.2	13	226-26303			25	400-62257	89	226-31709	39	400-25795	55	400-25811
Q	1	25.4	14	226-26402			26	400-62258	90	226-31808	40	400-25796	56	400-25812
R	1-1/8	28.6	15	226-26501					91	226-31907	41	400-25797	57	400-25813
S	1-1/4	31.8	16	226-26600					92	226-32004	42	400-25798	58	400-25814
T	1-3/8	34.9	17	226-26709					93	226-32103	43	400-25799	59	400-25815
U	1-1/2	38.1	18	226-26808					94	226-32202	44	400-25800	60	400-25816
Stitch spec.	S			★						★			★	
	Lower feed						★		★					
	G			★										★

Needle gauge			Presser foot (Lower feed)		Sliding plate, asm. (left)		Sliding plate, asm. (right)		Sliding plate, asm. (front)		
Cord											
	inch	mm	Ref.No.	Part No.	Ref.No.	Part No.	Ref.No.	Part No.	Ref.No.	Part No.	
B	1/8	3.2	61	232-05107							
C	5/32	4.0									
D	3/16	4.8	62	232-05305							
E	7/32	5.6									
F	1/4	6.4	63	232-05503			69	226-01058	73	226-00555	
G	9/32	7.1									
H	5/16	7.9	64	228-47800							
K	3/8	9.5									
W	7/16	11.1									
L	1/2	12.7			65	400-62249			77	400-34931	
M	5/8	15.9					70	226-01157	74	226-00654	
N	3/4	19.1			66	400-62251					
P	7/8	22.2			67	400-62252					
Q	1	25.4			68	400-62253	71	226-01256	75	226-00753	
R	1-1/8	28.6									
S	1-1/4	31.8									
T	1-3/8	34.9									
U	1-1/2	38.1					72	226-01355	76	226-00852	
Stitch spec.	S						Spec. common		Spec. common		Spec. common
	Lower feed										
	G			★		★					

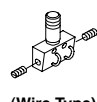
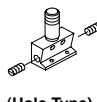
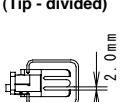
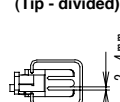
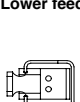



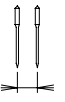
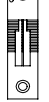
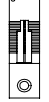
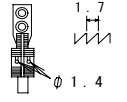
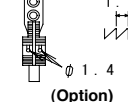
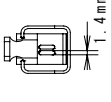
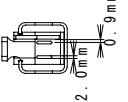

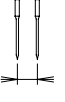
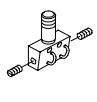
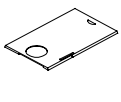
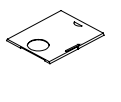
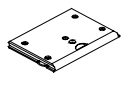
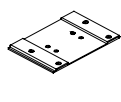
Needle gauge			Needle clamp asm.				Presser foot asm.					
Cord			 (Wire Type)		 (Hole Type)		 (Tip - divided)		 (Tip - divided)		 (Lower feed)	
	inch	mm	Ref. No.	Part No.	Ref. No.	Part No.	Ref. No.	Part No.	Ref. No.	Part No.	Ref. No.	Part No.
B	1/8	3.2	1	400-26027	62	101-47650	19	400-35896	80	400-35896 (Gap 2.0mm)	53	103-91852
C	5/32	4.0	2	400-26029	63	101-47759	20	400-35897	61	400-71909		
D	3/16	4.8	3	400-26031	64	101-47858	21	226-40353	37	228-16557	54	103-92058
E	7/32	5.6	4	400-26033	65	101-47957	22	226-40452	38	228-16656		
F	1/4	6.4	5	400-26035	66	101-48054	23	226-40551	39	228-16755	55	103-92256
G	9/32	7.1	6	400-26037	67	101-48153	24	226-40759	40	228-16854		
H	5/16	7.9	7	400-26039	68	101-48252	25	226-40858	41	228-16953	56	103-92454
K	3/8	9.5	8	400-26041	69	101-48351	26	226-40957	42	228-17050		
W	7/16	11.1	9	400-26043	70	101-48450	27	226-41054	43	400-33941		
L	1/2	12.7	10	400-26045	71	101-48559	28	226-41252	44	228-17159	57	103-92751
M	5/8	15.9	11	400-26047	72	101-48658	29	226-41351	45	400-33945		
N	3/4	19.1	12	400-26049	73	101-48757	30	226-41450	46	400-33947	58	103-93056
P	7/8	22.2	13	400-26051	74	101-48856	31	226-41658	47	400-33949	59	228-44450
Q	1	25.4	14	400-26053	75	101-48955	32	226-41757	48	400-33951	60	228-44559
R	1-1/8	28.6	15	400-26055	76	101-49052	33	226-41856	49	400-33953		
S	1-1/4	31.8	16	400-26057	77	101-49151	34	226-41955	50	400-33955		
T	1-3/8	34.9	17	400-26059	78	101-49250	35	226-42052	51	400-33957		
U	1-1/2	38.1	18	400-26061	79	101-49359	36	226-42151	52	400-33959		
Stitch spec.	S		★				★				★	
	Lower feed											
	G		★								★	



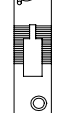

(2) LH-4128F

Needle gauge			Throat plate		Throat plate for taping		Feed dog				Presser foot asm.		Swivel guide Presser foot asm.	
Cord							 1.7 φ 1.4		 1.15 φ 1.4 (Option)		 1.4mm		 9mm	
	inch	mm	Ref. No.	Part No.	Ref. No.	Part No.	Ref. No.	Part No.	Ref. No.	Part No.	Ref. No.	Part No.	Ref. No.	Part No.
B	1/8	3.2	1	226-25107	7	226-28002	13	400-33563	19	400-35883	25	226-27152	31	226-47051
D	3/16	4.8	2	226-25305	8	226-28200	14	400-33564	20	400-35884	26	226-27350	32	226-47150
E	7/32	5.6	3	226-25404	9	226-28309	15	400-33565	21	400-35885	27	226-27459	33	226-47259
F	1/4	6.4	4	226-25503	10	226-28408	16	400-33566	22	400-35886	28	226-27558	34	226-47358
G	9/32	7.1	5	226-25602	11	226-28507	17	400-33567	23	400-35887	29	226-27657	35	226-47457
H	5/16	7.9	6	226-25701	12	226-28606	18	400-33568	24	400-35888	30	226-27756	36	226-47556

Needle gauge			Needle clamp asm.		Sliding plate, asm. (left)		Sliding plate, asm. (right)		Sliding plate, asm. (front)		Sliding plate, asm. (front) (with Taping)	
Cord												
	inch	mm	Ref. No.	Part No.	Ref. No.	Part No.	Ref. No.	Part No.	Ref. No.	Part No.	Ref. No.	Part No.
B	1/8	3.2	37	400-26027								
D	3/16	4.8	38	400-26031								
E	7/32	5.6	39	400-26033	43	226-01058	44	226-00555	45	400-34931	46	232-06709
F	1/4	6.4	40	400-26035								
G	9/32	7.1	41	400-26037								
H	5/16	7.9	42	400-26039								

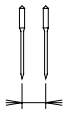
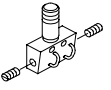
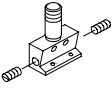
(3) LH-4128-7



Needle gauge			Throat plate				Feed dog				Presser foot asm.			
Cord														
	inch	mm	Ref. No.	Part No.	Ref. No.	Part No.	Ref. No.	Part No.	Ref. No.	Part No.	Ref. No.	Part No.	Ref. No.	Part No.
B	1/8	3.2	1	400-35881	78	400-61270	17	400-35890	33	400-53705	48	400-35896	93	400-35896 (Gap 2.0mm)
C	5/32	4.0	2	400-25485	79	400-61271	18	400-25817			49	400-35897	94	400-71909
D	3/16	4.8	3	400-25490	80	400-61272	19	400-25818	34	400-25831	50	226-40353	64	228-16557
E	7/32	5.6	4	400-25491	81	400-61273	20	400-25819	35	400-25832	51	226-40452	65	228-16656
F	1/4	6.4	5	400-25492	82	400-61274	21	400-26715	36	400-25833	52	226-40551	66	228-16755
G	9/32	7.1	6	400-25493	83	400-61275	22	400-25820	37	400-25834	53	226-40759	67	228-16854
H	5/16	7.9	7	400-25494	84	400-61276	23	400-25821	38	400-25835	54	226-40858	68	228-16953
K	3/8	9.5	8	400-25495	85	400-61277	24	400-25822	39	400-25836	55	226-40957	69	228-17050
W	7/16	11.1	9	400-25496			25	400-25823	40	400-25837	56	226-41054	70	400-33941
L	1/2	12.7	10	400-25498	86	400-61278	26	400-25824	41	400-25838	57	226-41252	71	228-17159
M	5/8	15.9	11	400-25499	87	400-61279	27	400-25825	42	400-25839	58	226-41351	72	400-33945
N	3/4	19.1	12	400-25500	88	400-61280	28	400-25826	43	400-25840	59	226-41450	73	400-33947
P	7/8	22.2	13	400-25502	89	400-61281	29	400-25827	44	400-25841	60	226-41658	74	400-33949
Q	1	25.4	14	400-25503	90	400-61282	30	400-25828	45	400-25842	61	226-41757	75	400-33951
R	1-1/8	28.6	15	400-25504	91	400-61283	31	400-25829	46	400-25843	62	226-41856	76	400-33953
S	1-1/4	31.8	16	400-25505	92	400-61284	32	400-25830	47	400-25844	63	226-41955	77	400-33955
Stitch spec.	S G		Spec. common				★		★		★		★	

Needle gauge			Needle clamp asm.				Sliding plate, asm. (left)		Sliding plate, asm. (right)		Sliding plate, asm. (front)		Wiper			
Cord																
	inch	mm	Ref. No.	Part No.	Ref. No.	Part No.	Ref. No.	Part No.	Ref. No.	Part No.	Ref. No.	Part No.	Ref. No.	Part No.		
B	1/8	3.2	1	400-26027	30	101-47650										
C	5/32	4.0	2	400-26029	31	101-47759										
D	3/16	4.8	3	400-26031	32	101-47858										
E	7/32	5.6	4	400-26033	33	101-47957										
F	1/4	6.4	5	400-26035	34	101-48054	17	400-25247	21	400-25235			26	102-09203		
G	9/32	7.1	6	400-26037	35	101-48153										
H	5/16	7.9	7	400-26039	36	101-48252										
K	3/8	9.5	8	400-26041	37	101-48351					25	400-31358				
W	7/16	11.1	9	400-26043	38	101-48450										
L	1/2	12.7	10	400-26045	39	101-48559							27	102-09500		
M	5/8	15.9	11	400-26047	40	101-48658	18	400-25248	22	400-25236						
N	3/4	19.1	12	400-26049	41	101-48757										
P	7/8	22.2	13	400-26051	42	101-48856										
Q	1	25.4	14	400-26053	43	101-48955	19	400-25249	23	400-25239						
R	1-1/8	28.6	15	400-26055	44	101-49052										
S	1-1/4	31.8	16	400-26057	45	101-49151	20	400-25250	24	400-25240						
Stitch spec.	S G		★				★		Spec. common		Spec. common		Spec. common		Spec. common	

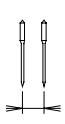
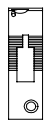
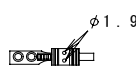
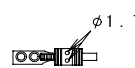
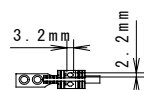
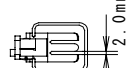
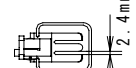
(4) LH-4168-7

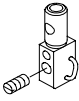
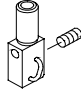
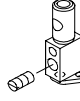
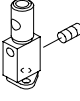
Needle gauge			Throat plate		Feed dog						Presser foot asm.			
Cord														
	inch	mm	Ref. No.	Part No.	Ref. No.	Part No.	Ref. No.	Part No.	Ref. No.	Part No.	Ref. No.	Part No.	Ref. No.	Part No.
B	1/8	3.2	1	400-35881	93	400-61270	13	400-35890	25	400-53705	36	400-35896	105	400-35896 (Gap 2.0mm)
C	5/32	4.0	2	400-25485	94	400-61271	14	400-25817			37	400-35897	130	400-71909
D	3/16	4.8	3	400-25490	95	400-61272	15	400-25818	26	400-25831	38	226-40353	48	228-16557
E	7/32	5.6	4	400-25491	96	400-61273	16	400-25819	27	400-25832	39	226-40452	49	228-16656
F	1/4	6.4	5	400-25492	97	400-61274	17	400-26715	28	400-25833	40	226-40551	50	228-16755
G	9/32	7.1	6	400-25493	98	400-61275	18	400-25820	29	400-25834	41	226-40759	51	228-16854
H	5/16	7.9	7	400-25494	99	400-61276	19	400-25821	30	400-25835	42	226-40858	52	228-16953
K	3/8	9.5	8	400-25495	100	400-61277	20	400-25822	31	400-25836	43	226-40957	53	228-17050
L	1/2	12.7	9	400-25498	101	400-61278	21	400-25824	32	400-25838	44	226-41252	54	228-17159
M	5/8	15.9	10	400-25499	102	400-61279	22	400-25825	33	400-25839	45	226-41351	55	400-33945
N	3/4	19.1	11	400-25500	103	400-61280	23	400-25826	34	400-25840	46	226-41450	56	400-33947
Q	1	25.4	12	400-25503	104	400-61282	24	400-25828	35	400-25842	47	226-41757	57	400-33951
Stitch spec.	S		Spec. common		★		★		★		★		★	
	G													

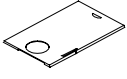
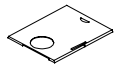
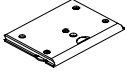

Needle gauge			Needle clamp asm. (left)		Needle clamp asm. (right)		Needle clamp asm. (left)		Needle clamp asm. (right)	
Cord										
	inch	mm	Ref. No.	Part No.	Ref. No.	Part No.	Ref. No.	Part No.	Ref. No.	Part No.
B	1/8	3.2	58	400-35877	70	400-35878	106	B1402-526-BA0-A	118	B1402-526-BA0-A
C	5/32	4.0	59	400-26063	71	400-26084	107	B1402-526-CA0-A	119	B1402-526-CA0-A
D	3/16	4.8	60	400-26065	72	400-26086	108	B1402-526-DAL-A	120	B1402-526-DAR-A
E	7/32	5.6	61	400-26067	73	400-26088	109	102-28559	121	102-28567
F	1/4	6.4	62	400-26069	74	400-26090	110	B1402-526-FAL-A	122	B1402-526-FAR-A
G	9/32	7.1	63	400-26070	75	400-26091	111	B1402-526-GAL-A	123	B1402-526-GAR-A
H	5/16	7.9	64	400-26072	76	400-26093	112	B1402-526-HAL-A	124	B1402-526-HAR-A
K	3/8	9.5	65	400-26074	77	400-26095	113	B1402-526-KAL-A	125	B1402-526-KAR-A
L	1/2	12.7	66	400-26076	78	400-26097	114	B1402-526-LAL-A	126	B1402-526-LAR-A
M	5/8	15.9	67	400-26078	79	400-26099	115	102-28856	127	102-28864
N	3/4	19.1	68	400-26080	80	400-26101	116	102-28955	128	102-28963
Q	1	25.4	69	400-26082	81	400-26103	117	102-29151	129	102-29169
Stitch spec.	S		★		★		★		★	
	G									

Needle gauge			Sliding plate, asm. (left)		Sliding plate, asm. (right)		Sliding plate, asm. (front)		Wiper	
Cord										
	inch	mm	Ref. No.	Part No.	Ref. No.	Part No.	Ref. No.	Part No.	Ref. No.	Part No.
B	1/8	3.2	82	400-25247	85	400-25235	88	400-31358	89	102-09203
C	5/32	4.0								
D	3/16	4.8								
E	7/32	5.6								
F	1/4	6.4								
G	9/32	7.1								
H	5/16	7.9	83	400-25248	86	400-25236		90	102-09500	
K	3/8	9.5								
L	1/2	12.7								
M	5/8	15.9								
N	3/4	19.1	84	400-25249	87	400-25239		91	102-09807	
Q	1	25.4								92
Stitch spec.	S		Spec. common		Spec. common		Spec. common		Spec. common	
	G									

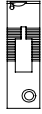
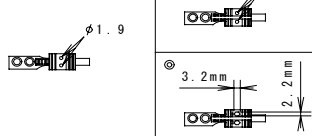
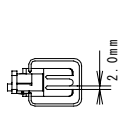
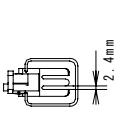
(5) LH-4188-7

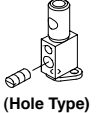
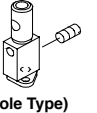
Needle gauge		Throat plate		Feed dog				Presser foot asm.				
Cord												
	inch	mm	Ref. No.	Part No.	Ref. No.	Part No.	Ref. No.	Part No.	Ref. No.	Part No.	Ref. No.	Part No.
B	1/8	3.2	1	400-35881	13	400-61270	25	400-53705	33	400-35896	91	400-35896 (Gap 2.0mm)
C	5/32	4.0	2	400-25485	14	400-61271	63	400-71911	34	400-35897	92	400-71909
D	3/16	4.8	3	400-25490	15	400-61272	26	400-35891	35	226-40353	45	228-16557
E	7/32	5.6	4	400-25491	16	400-61273	27	400-50009	36	226-40452	46	228-16656
F	1/4	6.4	5	400-25492	17	400-61274	28	400-35892	37	226-40551	47	228-16755
G	9/32	7.1	6	400-25493	18	400-61275	29	400-50010	38	226-40759	48	228-16854
H	5/16	7.9	7	400-25494	19	400-61276	30	400-50011	39	226-40858	49	228-16953
K	3/8	9.5	8	400-25495	20	400-61277	31	400-35893	40	226-40957	50	228-17050
L	1/2	12.7	9	400-25498	21	400-61278	32	400-35894	41	226-41252	51	228-17159
M	5/8	15.9	10	400-25499	22	400-61279	64	400-71912	42	226-41351		
N	3/4	19.1	11	400-25500	23	400-61280	65	400-35895	43	226-41450		
Q	1	25.4	12	400-25503	24	400-61282	66	400-71914	44	226-41757		
Stitch spec.	S G		Spec. common		★				★			

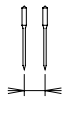
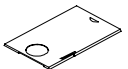
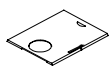
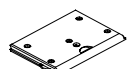
Needle gauge		Needle clamp asm. (left)		Needle clamp asm. (right)		
Cord						
	inch	mm	Ref. No.	Part No.	Ref. No.	Part No.
B	1/8	3.2	67	B1402-526-BA0-A	79	B1402-526-BA0-A
C	5/32	4.0	68	B1402-526-CA0-A	80	B1402-526-CA0-A
D	3/16	4.8	69	B1402-526-DAL-A	81	B1402-526-DAR-A
E	7/32	5.6	70	102-28559	82	102-28567
F	1/4	6.4	71	B1402-526-FAL-A	83	B1402-526-FAR-A
G	9/32	7.1	72	B1402-526-GAL-A	84	B1402-526-GAR-A
H	5/16	7.9	73	B1402-526-HAL-A	85	B1402-526-HAR-A
K	3/8	9.5	74	B1402-526-KAL-A	86	B1402-526-KAR-A
L	1/2	12.7	75	B1402-526-LAL-A	87	B1402-526-LAR-A
M	5/8	15.9	76	102-28856	88	102-28864
N	3/4	19.1	77	102-28955	89	102-28963
Q	1	25.4	78	102-29151	90	102-29169
Stitch spec.	S G		Spec. common		Spec. common	

Needle gauge		Sliding plate, asm. (left)		Sliding plate, asm. (right)		Sliding plate, asm. (front)		Wiper		
Cord										
	inch	mm	Ref. No.	Part No.	Ref. No.	Part No.	Ref. No.	Part No.	Ref. No.	Part No.
B	1/8	3.2	52	400-25247	55	400-25235	58	400-31358	59	102-09203
C	5/32	4.0								
D	3/16	4.8								
E	7/32	5.6								
F	1/4	6.4								
G	9/32	7.1								
H	5/16	7.9								
K	3/8	9.5	53	400-25248	56	400-25236		60	102-09500	
L	1/2	12.7								
M	5/8	15.9								
N	3/4	19.1	54	400-25249	57	400-25239		61	102-09807	
Q	1	25.4								62
Stitch spec.	S G		Spec. common		Spec. common		Spec. common		Spec. common	

9. TROUBLES AND CORRECTIVE MEASURES

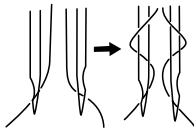
TROUBLES	CAUSES	CORRECTIVE MEASURES
<p>1. Thread breakage (Thread is untwisted or scraped.)</p> <p>(Needle thread 2 to 3 cm is left on the wrong side of the fabric.)</p>	<ul style="list-style-type: none"> ① There is a sharp edge or burr on the thread path, needle point, hook blade point or bobbin case resting groove on the throat plate. ② Needle thread tension is too high. ③ Bobbin case opening lever provides an excessive clearance at the bobbin case. ④ Hook blade point hits the needle. ⑤ Hook is not lubricated properly. ⑥ Needle thread tension is too low. ⑦ Thread take-up spring is too tight and its stroke is too small. ⑧ Needle-to-hook timing is wrong. ⑨ Thread untwists. ⑩ Uniform thread loops cannot be formed when making chain-off thread. 	<ul style="list-style-type: none"> ○ Remove sharp edge or burr using a fine sandpaper. Polish the surface of the bobbin case resting groove on the throat plate using a buffing wheel. ○ Adjust the needle thread tension. ○ Reduce the clearance. (Refer to "6-3. Adjusting the inner hook guide".) ○ Refer to "6-4. Needle-to-hook relation". ○ Increase the amount of oil supplied to the hook according to ("4-3. Adjusting the amount of oil in the hook (excluding dry hook type (DS and DF))"). ○ Adjust the needle thread tension. ○ Reduce the tension of the spring and increase the stroke. ○ Refer to "6-4. Needle-to-hook relation". ○ Wind the thread on the needle. <div style="text-align: center; margin: 10px 0;">  </div> <ul style="list-style-type: none"> ○ Use the thread guide equipped with felt pad.
<p>2. Stitch skipping</p>	<ul style="list-style-type: none"> ① Clearance between the needle and the hook blade point is too great. ② Needle-to-hook relation is wrong. ③ Pressing force of the presser foot is not enough. ④ Needle bar height is wrong. ⑤ Needles are a little too thin. ⑥ Synthetic thread or thin thread is used. 	<ul style="list-style-type: none"> ○ Refer to "6-4. Needle-to-hook relation". ○ Refer to "6-4. Needle-to-hook relation". ○ Tighten the presser spring regulator. ○ Refer to "6-4. Needle-to-hook relation". ○ Replace the needle by thicker ones. ○ Wind the thread on the needle.
<p>3. Loose stitch</p>	<ul style="list-style-type: none"> ① Bobbin thread does not pass through the forked end of the tension spring on the bobbin case. ② Thread path has rough surface. ③ Bobbin does not spin smoothly. ④ Bobbin case opening lever provides too much clearance at the bobbin. ⑤ Bobbin thread tension is too low. ⑥ Bobbin is wound too tightly. 	<ul style="list-style-type: none"> ○ Thread the bobbin case correctly. ○ Remove rough surface using a fine sandpaper or polish the surface using a buffing wheel. ○ Replace the bobbin or the hook. ○ Refer to "6-3. Adjusting the inner hook guide". ○ Adjust the bobbin thread tension. ○ Adjust the tension components on the bobbin winder.