

ENGLISH

**LH-3500A Series
INSTRUCTION MANUAL**

CONTENTS

| | |
|--|-----------|
| 1. SPECIFICATIONS..... | 1 |
| 2. NAME OF EACH COMPONENT | 3 |
| 3. INSTALLATION..... | 4 |
| 3-1. Caution at the time of set-up | 4 |
| 3-2. Installation of the sewing machine | 5 |
| 3-3. Adjusting the height of the knee lifter | 6 |
| 3-4. Installation of thread stand | 6 |
| 4. PREPARATION OF THE SEWING MACHINE | 7 |
| 4-1. Method of lubrication | 7 |
| 4-2. Lubrication to the oil tank | 8 |
| 4-3. Draining of oil from the oil tank..... | 9 |
| 4-4. Adjusting the amount of oil in the hook | 9 |
| 4-5. Oil in the feed box..... | 10 |
| 4-6. Applying grease | 11 |
| 4-7. Setting up the SC-920..... | 16 |
| 4-8. Installing the belt cover (For LH-3528A, 3568A, 3578A and 3588A)..... | 20 |
| 4-9. Attaching the needles..... | 20 |
| 4-10. How to take out the bobbin case..... | 21 |
| 4-11. Inserting a bobbin in a bobbin case..... | 21 |
| 4-12. Threading the machine head | 22 |
| 4-13. Thread tension | 25 |
| 4-14. Winding the bobbin thread | 26 |
| 4-15. Thread take-up spring | 27 |
| 4-16. Adjusting the stitch length..... | 29 |
| 4-17. Needle-to-hook relation..... | 29 |
| 4-18. Pedal pressure and pedal stroke..... | 31 |
| 4-19. Adjustment of the pedal | 31 |
| 5. OPERATION OF THE SEWING MACHINE | 32 |
| 5-1. Pedal Operation | 32 |
| 5-2. Hand lifter | 32 |
| 5-3. Adjusting the pressure of the presser foot | 33 |
| 5-4. Micro-lifter | 33 |
| 5-5. Thread tension release changeover when using the knee lifter..... | 34 |
| 5-6. One-touch manual reverse feed (One-touch reverse feed type) | 34 |
| 6. MAINTENANCE | 35 |
| 6-1. Procedure of changing over between bottom feed and needle feed and the adjustment (for LH-3528A only) | 35 |
| 6-2. Changing the feed timing..... | 37 |
| 6-3. Adjusting the thread trimming cam | 38 |
| 6-4. Adjusting the hook needle guard | 39 |
| 6-5. Adjusting the inner hook guide | 39 |
| 6-6. Adjusting the height and the inclination of the feed dog..... | 40 |
| 6-7. Replacing the gauge..... | 41 |
| 6-8. Adjusting the thread presser spring | 41 |
| 6-9. Adjusting the position of the moving knife | 42 |
| 6-10. Adjusting the counter knife position, knife pressure and clamp | 44 |
| 6-11. Position of the wiper..... | 46 |
| 6-12. Caution when installing the attachments | 46 |
| 6-13. Replacing the bobbin thread slack preventer spring (For LH-3568A, 3568A-7, 3588A and 3588A-7) | 47 |
| 6-14. Stop of the needle bars and angle of corners for corners stitching (For LH-3568A, 3568A-7, 3588A and 3588A-7) | 47 |
| 7. STITCH-TO-ANGLE TABLE BY GAUGE (PITCH AND mm CONVERSION TABLE) | 48 |
| 8. TROUBLES AND CORRECTIVE MEASURES | 49 |
| 9. MOTOR PULLEY AND BELT | 51 |

1. SPECIFICATIONS

| | | |
|--|---|---|
| Model name | LH-3528A | LH-3528A-7 (with automatic thread trimmer) |
| Application | For light -, medium - and heavy - weight materials | |
| | S type : standard, F type : foundation, A type : light-weight materials, G type : jeans | |
| Hook | Standard hook | Standard hook |
| Thread trimmer | Not provided | Provided |
| Separately driven needle bar mechanism | Not provided | Not provided |
| Max. sewing speed | 3,000 sti/min | |
| Needle * 1 | GROZ-BECKERT 134 Nm9 to Nm16 (For S, F and A types), 134 Nm16 to Nm23 (G type) ORGAN needle DP x 5 #9 to #16 (For S, F and A types), DP x 5 #16 to #23 (G type) | |
| Gauge size | 3/32" to 1-1/2" | 1/8" to 1-1/4" |
| | 2.4 to 38.1 mm | 3.2 to 31.8 mm |
| Lift of presser foot | 13 mm by knee lifter, 7 mm by hand lifter lever | |
| Lubrication | JUKI NEW DEFRIX OIL No. 1 or JUKI MACHINE OIL #7 | |
| Noise | Declaration - Equivalent continuous emission sound pressure level (L_{pA}) at the workstation : A-weighted value of 87.5 dB ; (Includes $K_{pA} = 2.5$ dB) ; according to ISO 10821-C.6.2 -ISO 11204 GR2 at 3,000 sti/min. - Sound power level (L_{WA}) : A-weighted value of 91.5 dB ; (Includes $K_{pA} = 2.5$ dB) ; according to ISO 10821-C.6.2 -ISO 3744 GR2 at 3,000 sti/min. | Declaration - Equivalent continuous emission sound pressure level (L_{pA}) at the workstation : A-weighted value of 85.5 dB ; (Includes $K_{pA} = 2.5$ dB) ; according to ISO 10821-C.6.2 -ISO 11204 GR2 at 3,000 sti/min. - Sound power level (L_{WA}) : A-weighted value of 90.5 dB ; (Includes $K_{pA} = 2.5$ dB) ; according to ISO 10821-C.6.2 -ISO 3744 GR2 at 3,000 sti/min. |
| | | |
| Model name | LH-3568A (with incorporating corner stitching) | LH-3568A-7 (with automatic thread trimmer incorporating corner stitching) |
| Application | For light -, medium - and heavy - weight materials | |
| | S type : standard, G type : jeans | |
| Hook | Standard hook | Standard hook |
| Thread trimmer | Not provided | Provided |
| Separately driven needle bar mechanism | Provided | Provided |
| Max. sewing speed | 3,000 sti/min | |
| Needle * 1 | GROZ-BECKERT 134 Nm9 to Nm16 (S type), 134 Nm16 to Nm23 (G type) ORGAN needle DP x 5 #9 to #16 (S type), DP x 5 #16 to #23 (G type) | |
| Gauge size | 1/8" to 3/4" | |
| | 3.2 to 19.1 mm | |
| Lift of presser foot | 13 mm by knee lifter, 7 mm by hand lifter lever | |
| Lubrication | JUKI NEW DEFRIX OIL No. 1 or JUKI MACHINE OIL #7 | |
| Noise | Declaration - Equivalent continuous emission sound pressure level (L_{pA}) at the workstation : A-weighted value of 83.5 dB ; (Includes $K_{pA} = 2.5$ dBA) ; according to ISO 10821-C.6.2 -ISO 11204 GR2 at 3,000 sti/min. - Sound power level (L_{WA}) : A-weighted value of 87.5 dB ; (Includes $K_{pA} = 2.5$ dBA) ; according to ISO 10821-C.6.2 -ISO 3744 GR2 at 3,000 sti/min. | Declaration - Equivalent continuous emission sound pressure level (L_{pA}) at the workstation : A-weighted value of 84 dBA ; (Includes $K_{pA} = 2.5$ dB) ; according to ISO 10821-C.6.2 -ISO 11204 GR2 at 3,000 sti/min. - Sound power level (L_{WA}) : A-weighted value of 88.5 dBA ; (Includes $K_{pA} = 2.5$ dB) ; according to ISO 10821-C.6.2 -ISO 3744 GR2 at 3,000 sti/min. |
| | | |

* 1 : Needle used depends on the destination.

| | | |
|--|---|---|
| Model name | LH-3578A | LH-3578A-7 (with automatic thread trimmer) |
| Application | For medium - and heavy - weight materials | |
| | G type : jeans | |
| Hook | Large hook | Large hook |
| Thread trimmer | Not provided | Provided |
| Separately driven needle bar mechanism | Not provided | Not provided |
| Max. sewing speed | 3,000 sti/min | |
| Needle * 1 | GROZ-BECKERT 134 Nm16 to Nm23 (G type) ORGAN needle DP x 5 #16 to #23 (G type) | |
| Gauge size | 3/16" to 1-1/12" | 3/16" to 3/8" |
| | 4.8 to 38.1 mm | 4.8 to 9.5 mm |
| Lift of presser foot | 13 mm by knee lifter, 7 mm by hand lifter lever | |
| Lubrication | JUKI NEW DEFRIX OIL No. 1 or JUKI MACHINE OIL #7 | |
| Noise | <p>Declaration</p> <ul style="list-style-type: none"> - Equivalent continuous emission sound pressure level (L_{pA}) at the workstation : A-weighted value of 87.5 dB ; (Includes $K_{pA} = 2.5$ dB) ; according to ISO 10821-C.6.2 -ISO 11204 GR2 at 3,000 sti/min. - Sound power level (L_{WA}) : A-weighted value of 91.5 dB ; (Includes $K_{pA} = 2.5$ dB) ; according to ISO 10821-C.6.2 -ISO 3744 GR2 at 3,000 sti/min. | <p>Declaration</p> <ul style="list-style-type: none"> - Equivalent continuous emission sound pressure level (L_{pA}) at the workstation : A-weighted value of 85.5 dB ; (Includes $K_{pA} = 2.5$ dB) ; according to ISO 10821-C.6.2 -ISO 11204 GR2 at 3,000 sti/min. - Sound power level (L_{WA}) : A-weighted value of 90.5 dB ; (Includes $K_{pA} = 2.5$ dB) ; according to ISO 10821-C.6.2 -ISO 3744 GR2 at 3,000 sti/min. |

| | | |
|--|---|---|
| Model name | LH-3588A (with incorporating corner stitching) | LH-3588A-7 (with automatic thread trimmer incorporating corner stitching) |
| Application | For medium - and heavy - weight materials | |
| | G type : jeans | |
| Hook | Large hook | Large hook |
| Thread trimmer | Not provided | Provided |
| Separately driven needle bar mechanism | Provided | Provided |
| Max. sewing speed | 3,000 sti/min | |
| Needle * 1 | GROZ-BECKERT 134 Nm16 to Nm23 (G type) ORGAN needle DP x 5 #16 to #23 (G type) | |
| Gauge size | 3/16" to 3/8" | |
| | 4.8 to 9.5 mm | |
| Lift of presser foot | 13 mm by knee lifter, 7 mm by hand lifter lever | |
| Lubrication | JUKI NEW DEFRIX OIL No. 1 or JUKI MACHINE OIL #7 | |
| Noise | <p>Declaration</p> <ul style="list-style-type: none"> - Equivalent continuous emission sound pressure level (L_{pA}) at the workstation : A-weighted value of 83.5 dB ; (Includes $K_{pA} = 2.5$ dBA) ; according to ISO 10821-C.6.2 -ISO 11204 GR2 at 3,000 sti/min. - Sound power level (L_{WA}) : A-weighted value of 87.5 dB ; (Includes $K_{pA} = 2.5$ dBA) ; according to ISO 10821-C.6.2 -ISO 3744 GR2 at 3,000 sti/min. | <p>Declaration</p> <ul style="list-style-type: none"> - Equivalent continuous emission sound pressure level (L_{pA}) at the workstation : A-weighted value of 84 dBA ; (Includes $K_{pA} = 2.5$ dB) ; according to ISO 10821-C.6.2 -ISO 11204 GR2 at 3,000 sti/min. - Sound power level (L_{WA}) : A-weighted value of 88.5 dBA ; (Includes $K_{pA} = 2.5$ dB) ; according to ISO 10821-C.6.2 -ISO 3744 GR2 at 3,000 sti/min. |

* 1 : Needle used depends on the destination.

2. NAME OF EACH COMPONENT

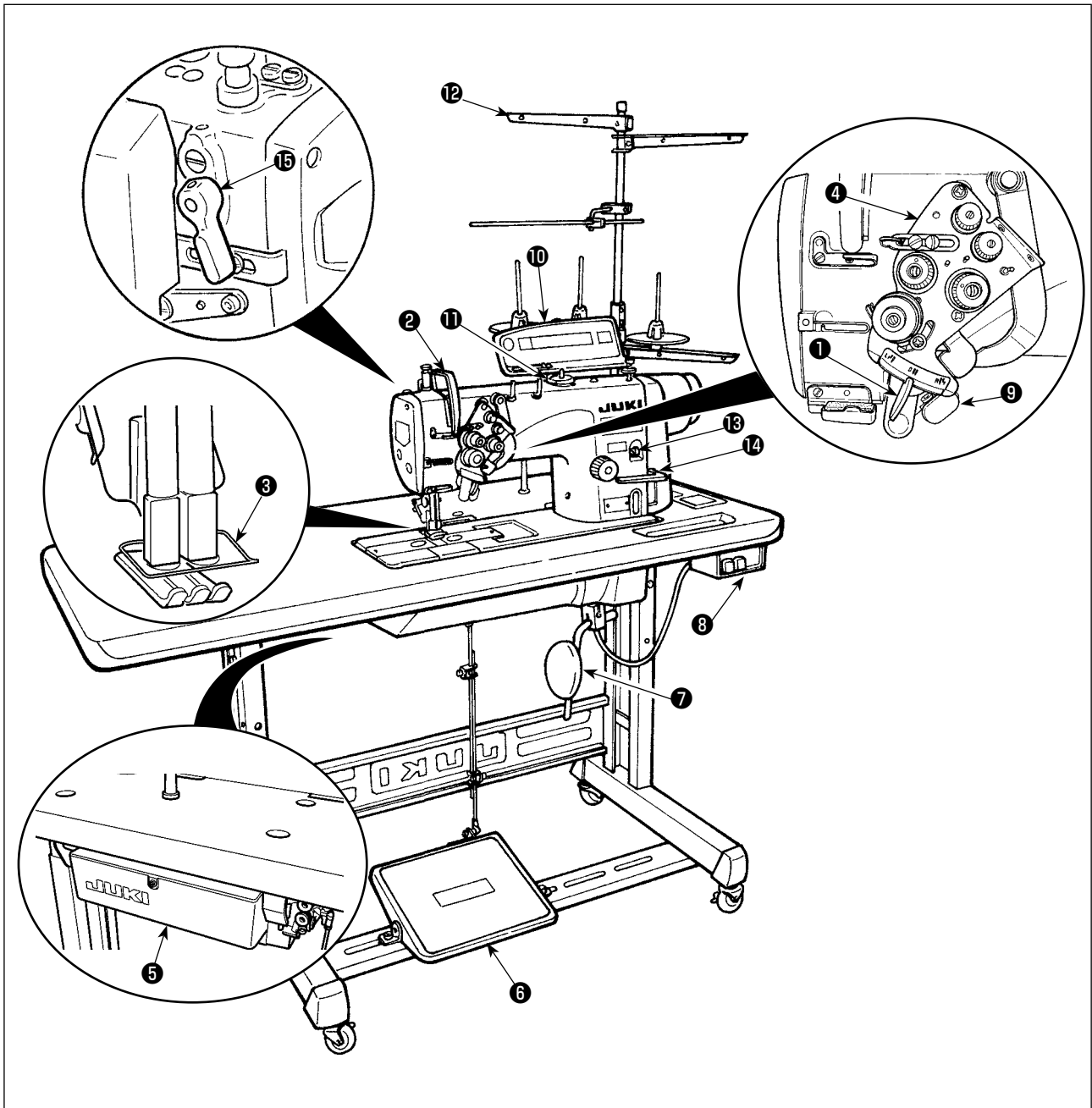

- | | |
|--|--|
| ① Separately driven needle changeover lever (LH-3568A, 3568A-7, 3588A, 3588A-7) | ⑧ Power switch |
| ② Thread take-up cover | ⑨ Reverse feed switch (LH-3528A-7, 3568A-7, 3528A (F type), 3578A-7, 3588A-7) |
| ③ Finger guard | ⑩ Operation panel |
| ④ Thread tension controller | ⑪ Bobbin winder |
| ⑤ Control box | ⑫ Thread stand |
| ⑥ Pedal | ⑬ Oil supply opening |
| ⑦ Knee pad | ⑭ Reverse feed control lever |
| | ⑮ Hand lifter lever |

3. INSTALLATION

3-1. Caution at the time of set-up

(1) Transporting procedure of the sewing machine

[LH-3528A, 3568A, 3578A, 3588A]

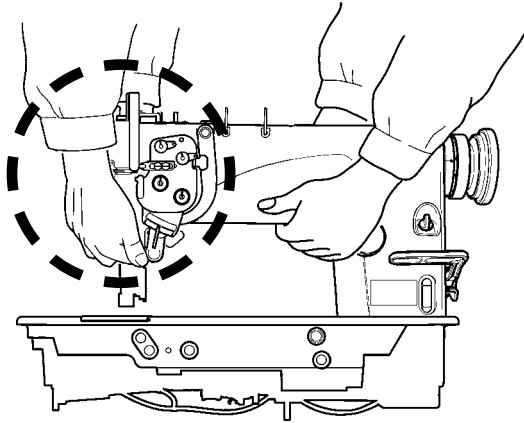

[LH-3528A-7, 3568A-7, 3578A-7, 3588A-7]

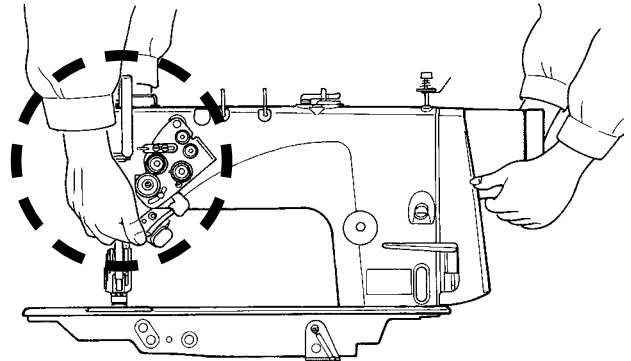

Hold and transport the sewing machine with two persons as shown in the illustration.



When carrying the sewing machine, take extreme care not to hold the thread tension controllers by hand. (If you hold the thread tension controllers by hand, they can break.)

(2) Caution when placing the sewing machine

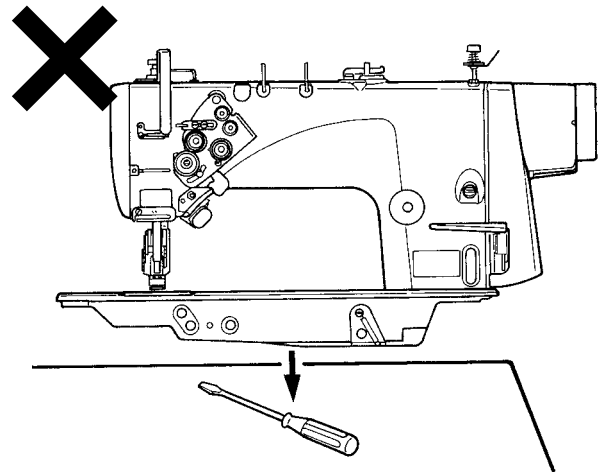
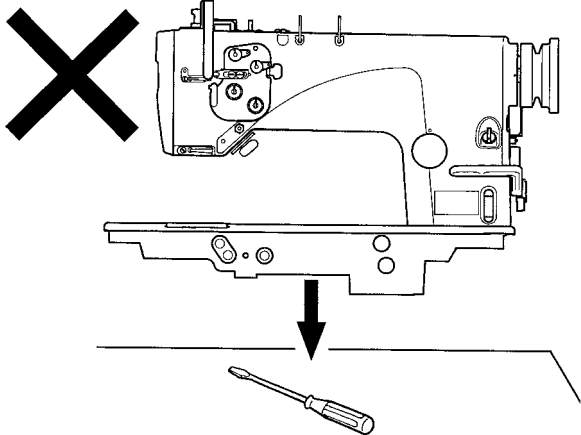

Do not put protruding articles such as the screwdriver and the like at the location where the sewing machine is placed.

3-2. Installation of the sewing machine

(1) Installing the under cover

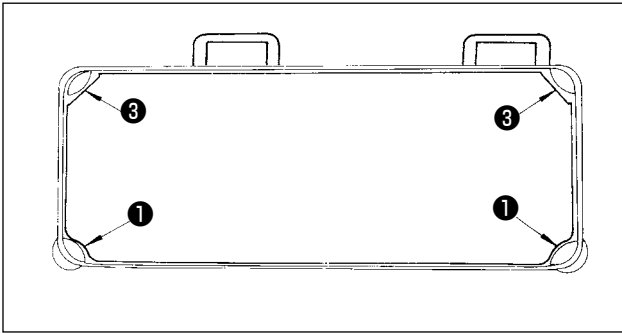

1) The under cover should rest on the four corners of the machine table groove.

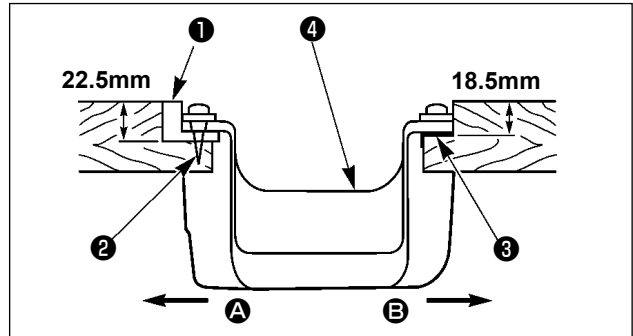

2) Fix two rubber seats **1** on side **A** (operator's side) using nails **2** as illustrated above. Fix two cushion seats **3** on side **B** (hinged side) using a rubber-based adhesive. Then place under cover **4** on the fixed seats.

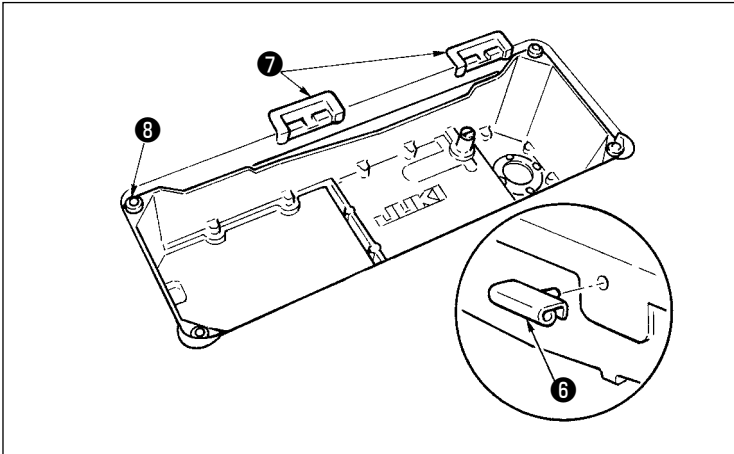

3) Mount rubber hinge seats **7** on the table and fix the table with nails. Insert hinge **6** into the machine main body. Engage the hinges with rubber hinge seats **7** mounted on the table. Then, put the machine head down on the machine head cushions **8** which are located at the four corners of the table.

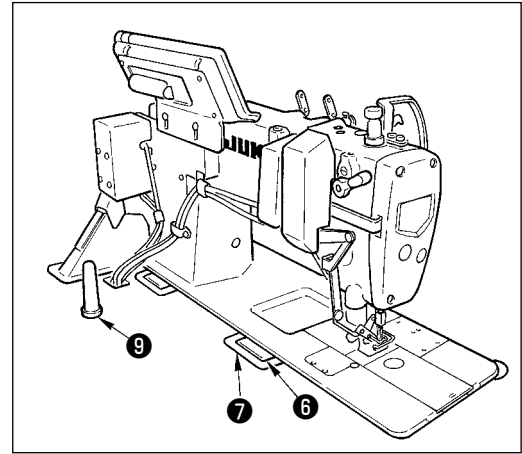

4) Attach head support rod **9** to the table.

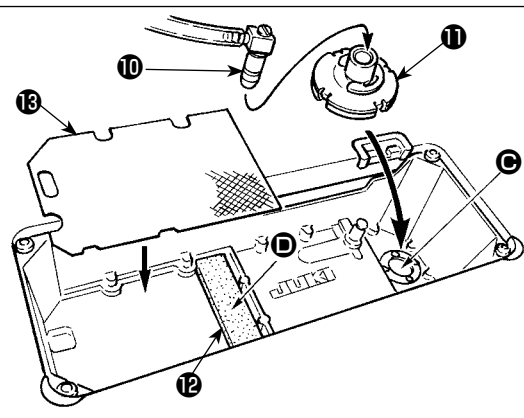
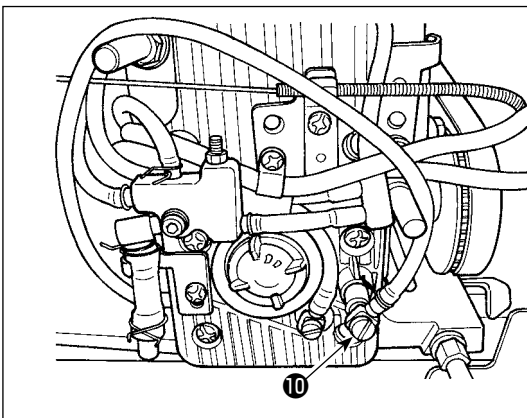

5) Detach inlet port **10** for circulation which is fixed on the feed box cover. Insert the inlet port into filter **11** until it will go no further without fail and place them in opening **C**. Place urethan filter **12** on **D**, and place filter **13** of thin plate type (small mesh plate) on it.



Caution Circulation trouble may occur unless inlet port **10** for circulation is securely inserted into filer **11** until it goes no further.

3-3. Adjusting the height of the knee lifter



WARNING :

To protect against possible personal injury due to abrupt start of the machine, be sure to start the following work after turning the power off and ascertaining that the motor is at rest.

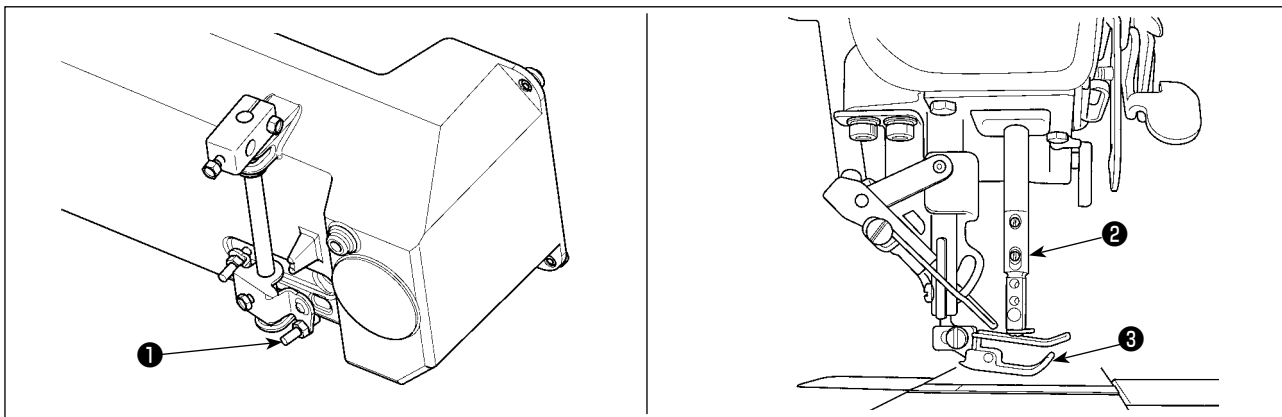

- 1) The standard height of the presser foot lifted using the knee lifter is 12 mm.
- 2) You can adjust the presser foot lift up to 13 mm using knee lifter adjust screw **1**.



Do not operate the sewing machine in the state that the presser foot **3** is lifted by 12 mm or more since the needle bar **2** comes in contact with the presser foot **3**.

3-4. Installation of thread stand

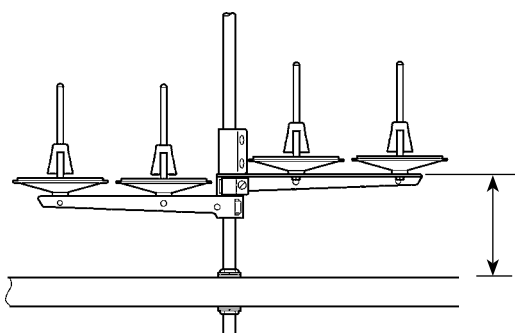
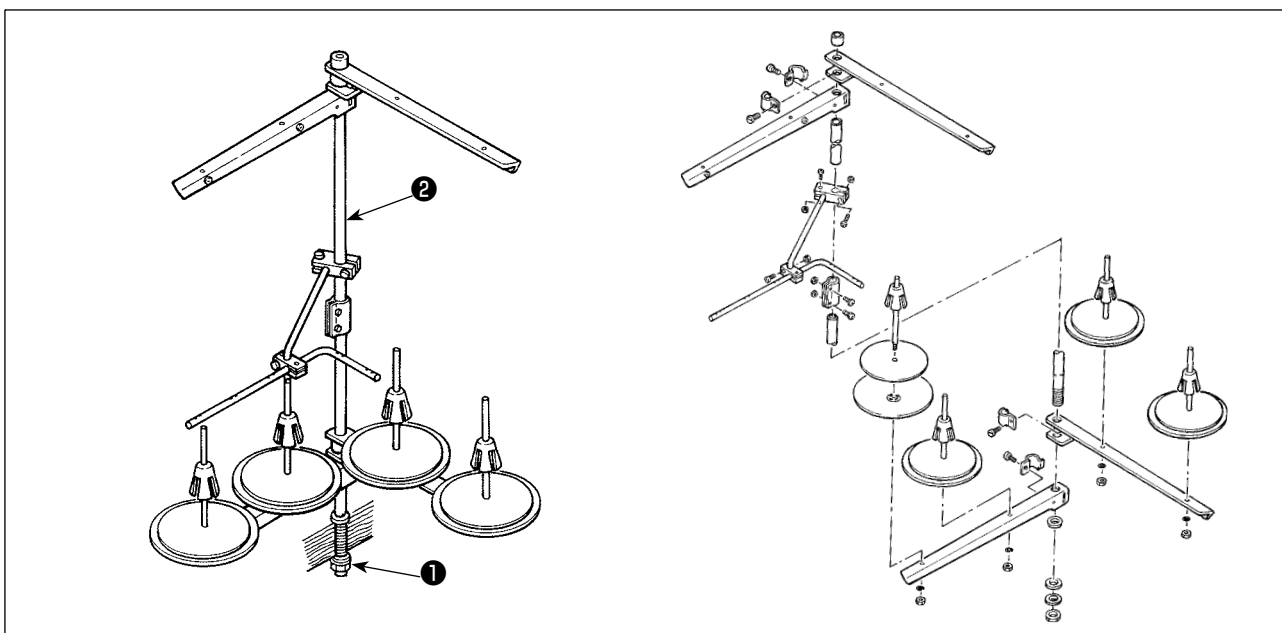

Assemble the thread stand, set it up on the machine table using the installation hole in the table and tighten nut **1** gently.

When you use power supplied by the overhead power line, pass the power supply cord through hollow spool rest rod **2**.

4. PREPARATION OF THE SEWING MACHINE

4-1. Method of lubrication

For this sewing machine, one of two different lubricating methods can be selected.

(1) Method of circulating lubrication (when the oil collected in the under cover is reused)

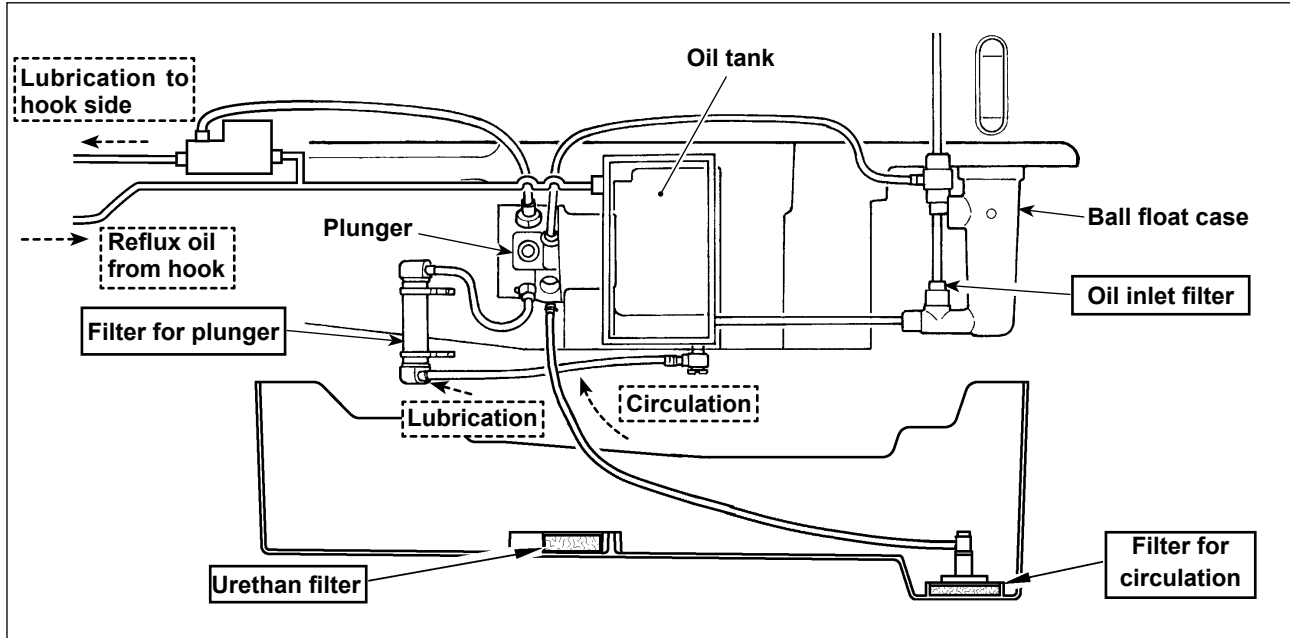

To ensure the long service life of the sewing machine, be sure to clean up the aforementioned filter sections (at four locations) periodically (approximately once three months). When the filter is clogged, lubrication trouble will occur and break-down will be caused. In addition, when the oil becomes dirty, replace the oil gathered in the oil tank and the under cover.

(2) Method of non-circulation type lubrication (when only the clean oil is always used)

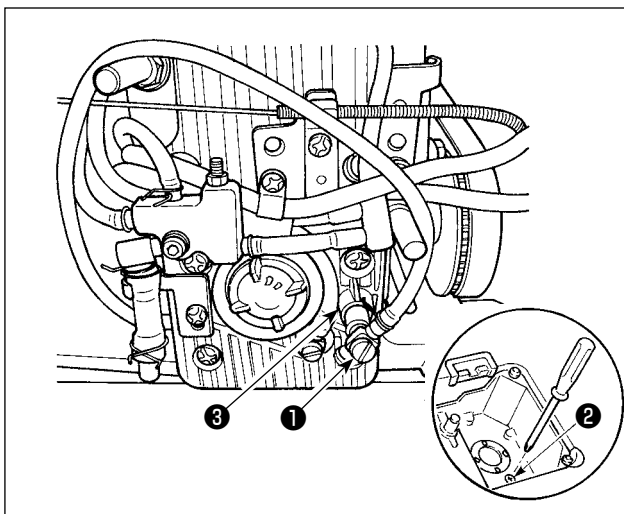

Insert inlet port ❶ for circulation into section ❸ of the feed box cover until it will go no further to put it into the state as it has been delivered to your plant.

* Drain oil dropped into the under cover by removing drain screw ❷ .



When inlet port for circulation ❶ comes in contact with the oil surface, oil is absorbed without passing the filter. As a result, break-down will be caused. If inlet port ❶ for circulation is not inserted into the feed box cover, oil may leak from inlet port ❶ for circulation or the quantity of oil in the hook may fluctuate.

4-2. Lubrication to the oil tank



WARNING :

1. Do not connect the power plug until the lubrication has been completed so as to prevent accidents due to abrupt start of the sewing machine,
2. To prevent the occurrence of an inflammation or rash, immediately wash the related portions if oil adheres to your eyes or other parts of your body.
3. If oil is mistakenly swallowed, diarrhea or vomiting may occur. Put oil in a place where children cannot reach.

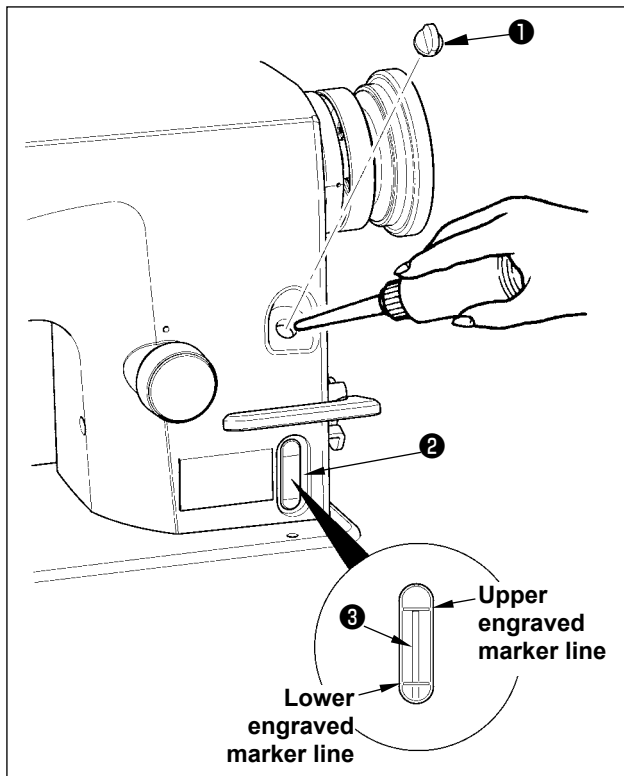

Fill the oil tank with oil for hook lubrication before operating the sewing machine.

- 1) Remove oil hole cap ❶ and fill the oil tank with JUKI NEW DEFRIX OIL No.1 (Part No. : MD-FRX1600C0) or JUKI MACHINE OIL #7 (Part No. : MML007600CA) using the oiler supplied with the machine.
- 2) Add oil until the top end of oil amount indicating rod ❸ does not go above the upper engraved marker line.

If the oil tank is filled with an excessive amount of oil, oil will leak from the air vent hole in the ball float case or proper lubrication will not be carried out. So, be careful.

- 3) When you operate the sewing machine, refill oil if the top end of oil amount indicating rod ❸ comes down to the lower engraved marker line of oil amount indicating window ❷ .



- For the first time you fill the oil tank with oil, add 280 cc of oil as a guide and check to be sure that the oil amount indicating rod works. If the oil amount indicating rod does not work, bring it to the workable state by tilting the sewing machine once.
- When you use a new sewing machine or a sewing machine after an extended period of disuse, use the sewing machine after performing break-in at 2,000 sti/min or less.
- For the oil for hook lubrication, purchase JUKI NEW DEFRIX OIL No. 1 (Part No. : MD-FRX1600C0) or JUKI MACHINE OIL #7 (Part No. : MML007600CA).
- Be sure to lubricate clean oil.



In case of the circulation type lubrication method, when using the sewing machine for the first time, the oil amount in the oil tank decreases until the oil has collected in the filer for circulation. When the top end of oil amount indicating rod is lower than the lower engraved marker line, add the oil to the oil tank again so that the top end enters between the upper and lower engraved marker lines.



- This sewing machine differs in structure from general lockstitch machines. Be aware that the response of the oil amount indicating rod to the actual oil amount is slower than that of the general lockstitch machines when lubricating the oil tank. It is, therefore, necessary to add oil to the oil tank slowly.
- Especially when the sewing machine uses the circulation type lubrication method (the oil accumulated in the bottom cover is circulated), the oil is circulated in the sewing machine and is returned to the oil tank. It is, therefore, necessary to run the sewing machine until the oil amount indicating rod is stabilized before lubrication.

4-3. Draining of oil from the oil tank



WARNING :

1. To prevent accidents caused by abrupt start of the sewing machine, do not connect the power plug until draining of oil has been completed.
2. To prevent the occurrence of an inflammation or rash, immediately wash the related portions if oil adheres to your eyes or other parts of your body.
3. If oil is mistakenly swallowed, diarrhea or vomiting may occur. Put oil in a place where children cannot reach.

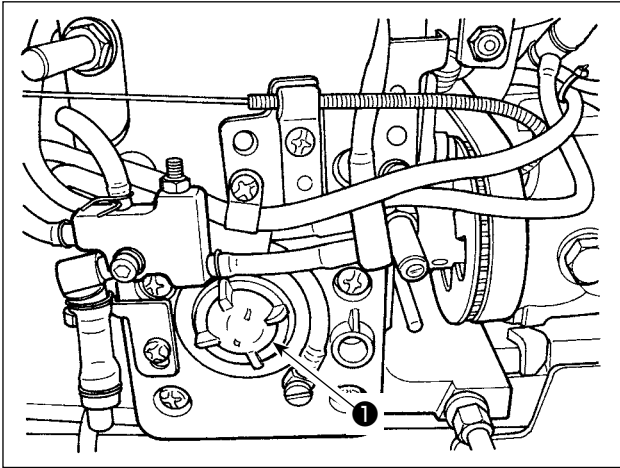

When draining oil from the oil tank, loosen and remove oil confirming window ❶ .



Oil may burst out from the oil confirming window at the time of draining.

It is recommended, in this case, only to loosen the oil confirming window instead of removing it. Then, drain oil while controlling the oil amount bursting out from the oil amount confirming window ❶ .

4-4. Adjusting the amount of oil in the hook



WARNING :

To protect against possible personal injury due to abrupt start of the machine, be sure to start the following work after turning the power off and ascertaining that the motor is at rest.

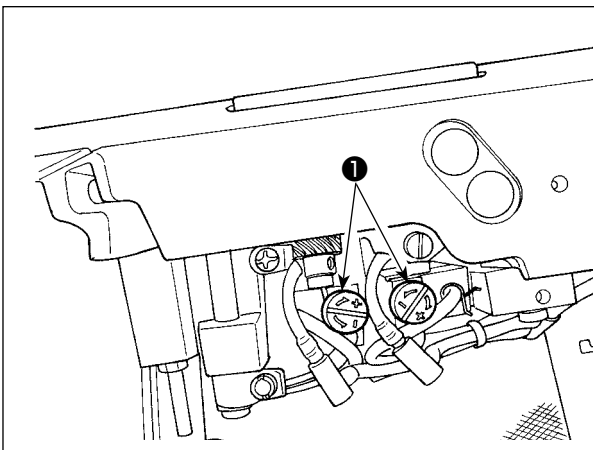

Oil amount decrease

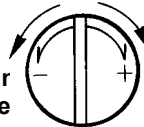

Oil amount increases

Oil splashes

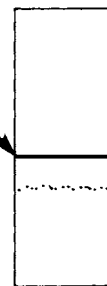

Adjust the amount oil using adjusting screw ❶ . Turn screw ❶ clockwise to increase the amount of oil in the hook or counterclockwise to decrease it. Measure the amount of oil in five seconds. When the amount of oil is excessively decreased, break-down will be caused. So, be careful.



To use in safety, replace the oil wick of hook section with a new one approximately once a year with the procedure below.

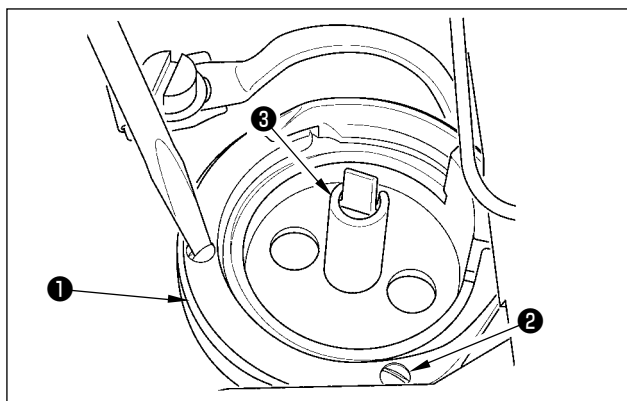

1) Loosen setscrews (2) (small hook : 2 places, large hook : 3 places) and remove hook gib (1) .

2) Remove inner hook (3) .

3) Loosen oil plug (4) with the L-shaped screwdriver (Part No. : B9101490000) and remove it.

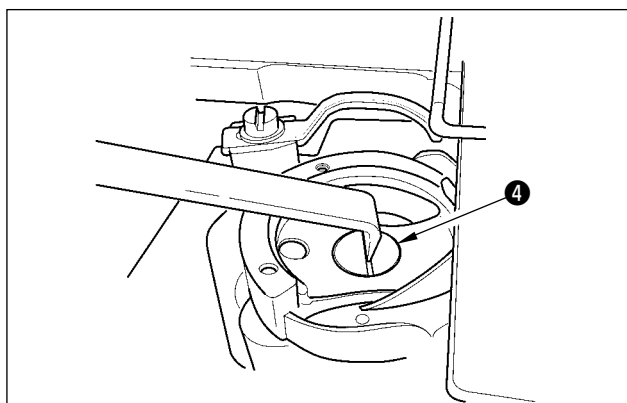

4) Draw out oil wick (5) inserted into oil plug (4) , and replace it with a new one.

[Part No. of oil wick (5)]

| | |
|---------------------------------|----------|
| Small hook / Large hook | 11015906 |
| Oil Q'ty in the hook is largish | 11404704 |



When strongly pressing oil wick (5) , it may be broken. Lightly insert it to such an extent that it is not drawn out.

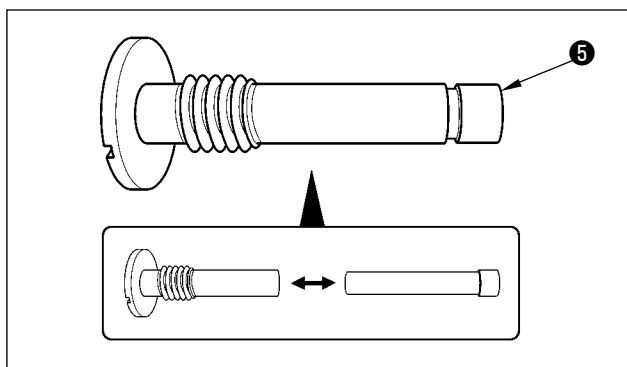

After the replacement, assemble oil plug (4) , inner hook (3) and hook gib (1) to the hook by reversing the above procedure. Perform confirming of oil splash.



When loosening/assembling, do not allow the slit section of oil plug (4) to be burred.

4-5. Oil in the feed box

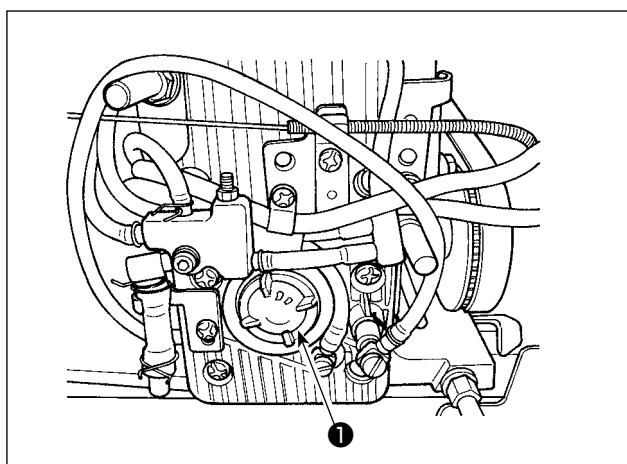

When using the sewing machine, make sure that the oil is put in the feed box from oil confirming window (1) .



If you find abnormal discoloring of oil or dust in the oil through the oil amount indicating window, loosen the window to drain oil and fill the oil tank with new oil.

4-6. Applying grease



WARNING :

To protect against possible personal injury due to abrupt start of the machine, be sure to start the following work after turning the power off and ascertaining that the motor is at rest.

1. In the case you use the SC-920 with your sewing machine, the warning alarm will sound when the time for grease-up comes. When the alarm sounds, apply grease to the grease applying sections of the sewing machine. If you use the sewing machine in harsh conditions such as high temperature, high operating rate and dusty environment, it is recommended to perform grease-up periodically once or more every six months to ensure efficient operation of the sewing machine.



2. Never lubricate oil to the grease applying places.
3. When grease is applied more than is necessary, there is a fear that grease leaks from the thread take-up lever cover section or the needle bar. So, be careful.
4. Be sure to apply GREASE N (part number: 40224439) to the needle bar frame shaft section. For other grease applying sections of the sewing machine, use supplied JUKI GREASE A TUBE (part number: 40006323).

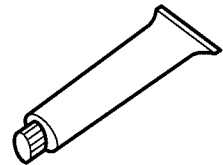

JUKI GREASE A TUBE
Parts No. : 40006323

(1) Sections to be applied with grease

[LH-3528A, 3528A-7, 3578A, 3578A-7]

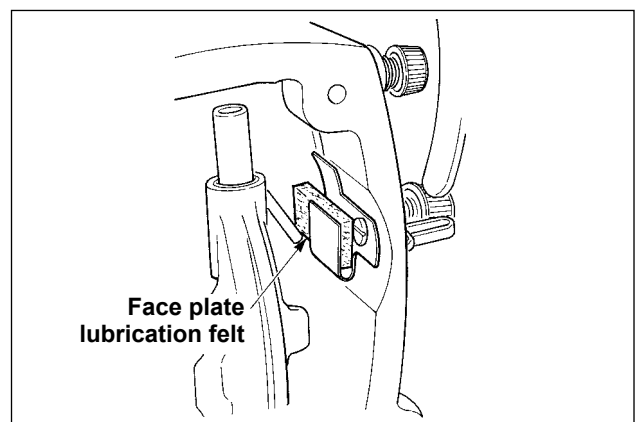
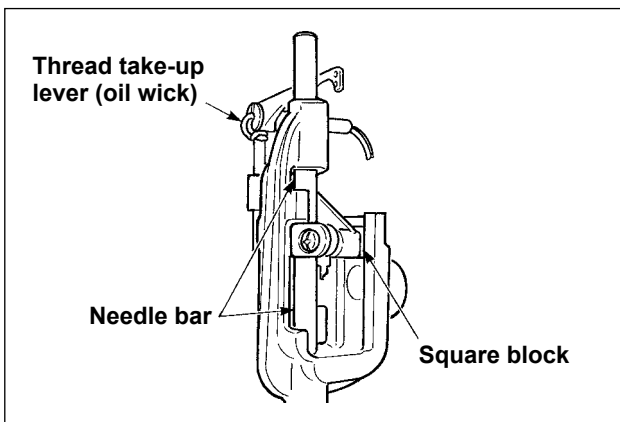

[LH-3528A-7, 3568A-7, 3578A-7, 3588A-7]

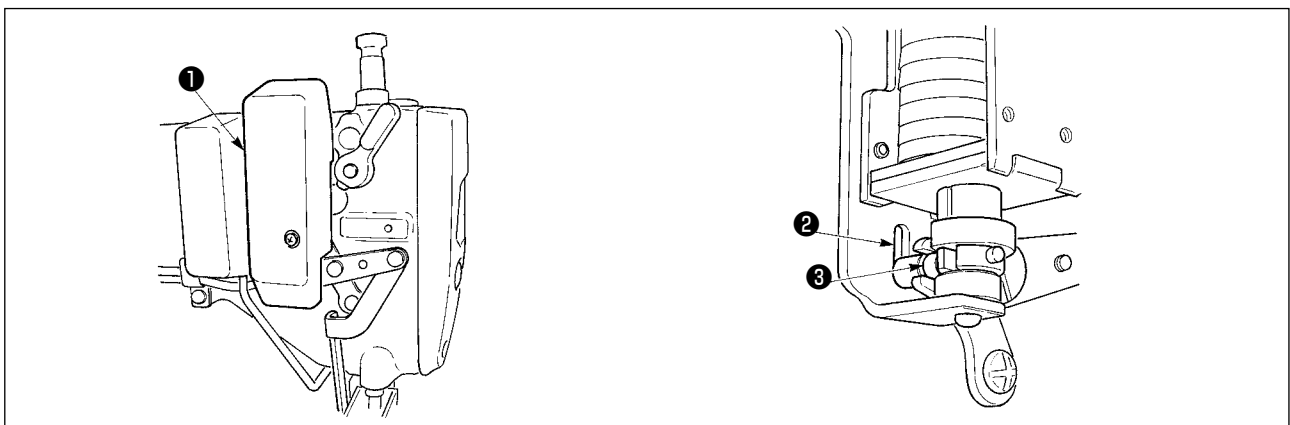

Remove wiper cover ①, and apply grease to slot section ② of wiper solenoid base and wiper link collar ③.

[LH-3568A, 3568A-7, 3588A, 3588A-7]

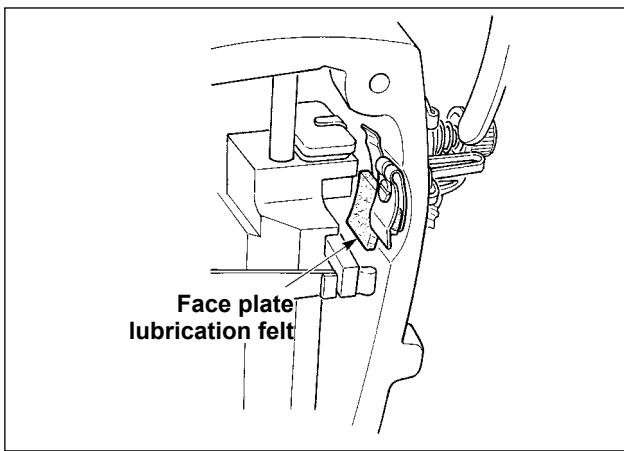
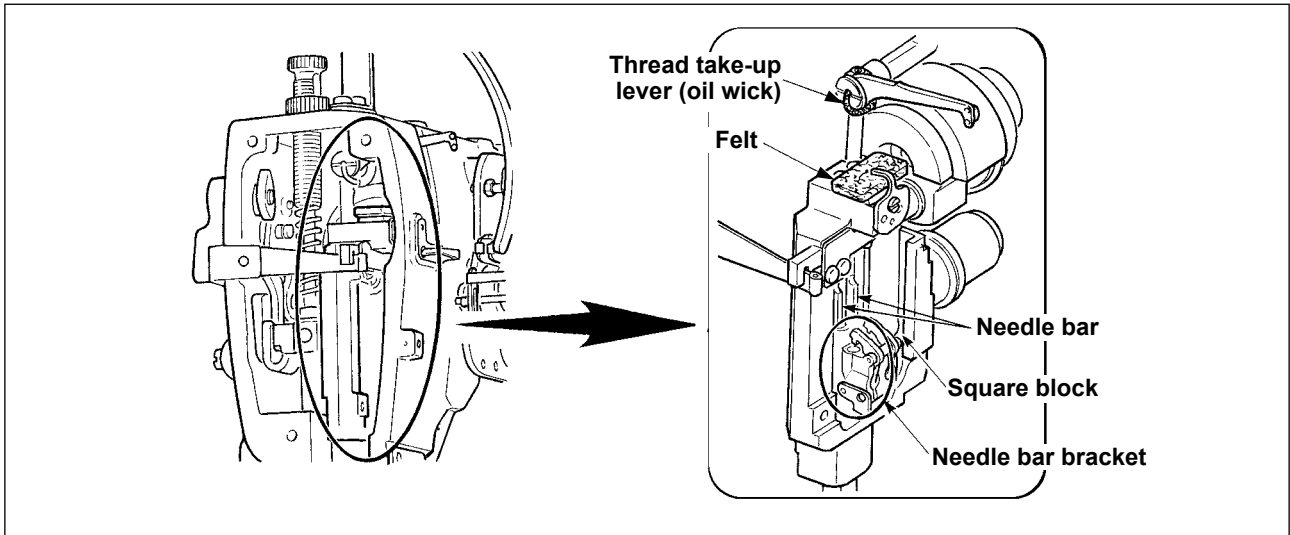

[Common]

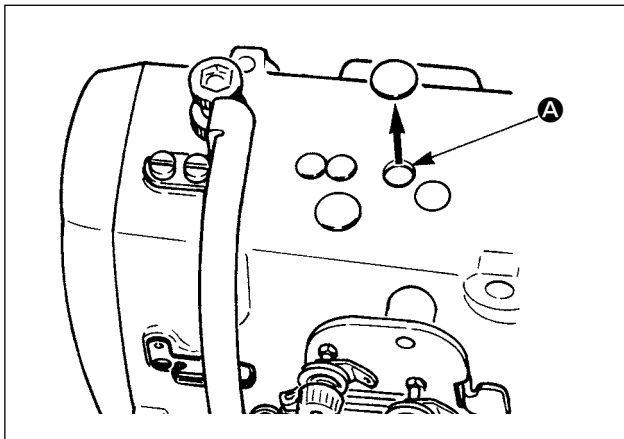

Remove the rubber cap, take out the felt in **A**, pour new grease in the hole, and put the felt to which grease has been soaked after removing old grease adhered to the inside of the hole and the felt. Further, pour grease above the felt and cover it with the rubber cap.

(2) Greasing up the rear part of the needle bar frame shaft

[Motor type]

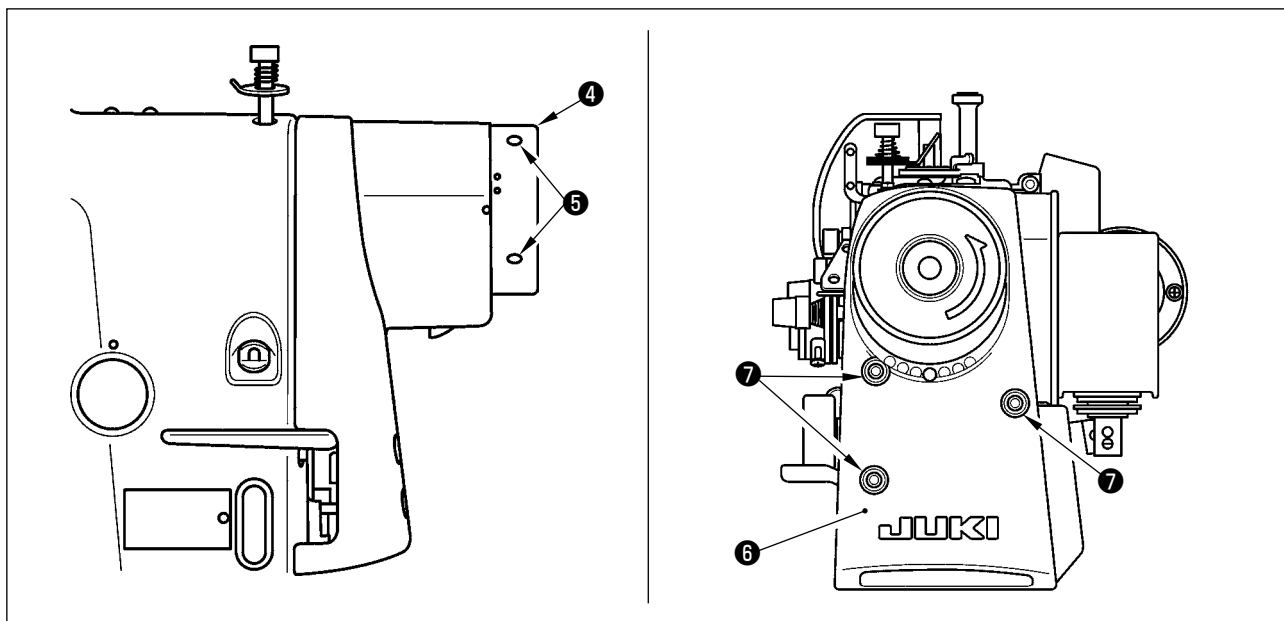

- 1) Loosen handwheel fixing screws ⑤ . Detach handwheel ④ .
- 2) Loosen motor cover fixing screws ⑦ . Detach motor cover ⑥ .

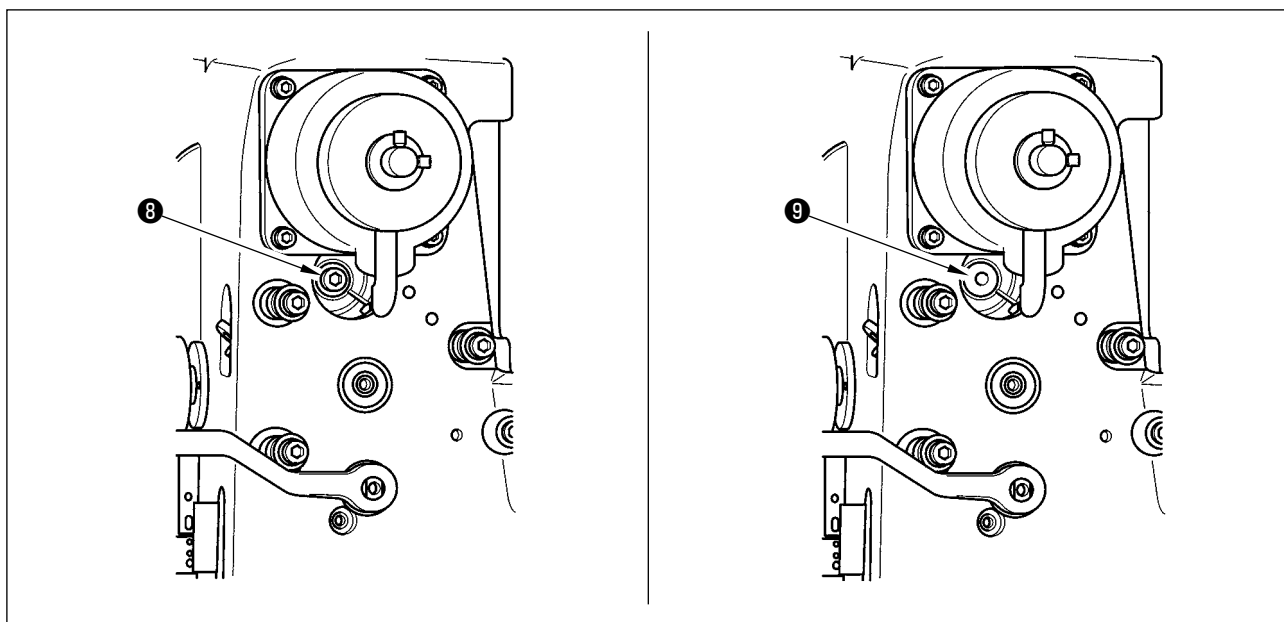

- 3) Remove screw ⑧ with a hexagonal wrench.
- 4) Refill rear grease hole ⑨ of the needle bar frame shaft with the GREASE N using a syringe.

[Belt type]

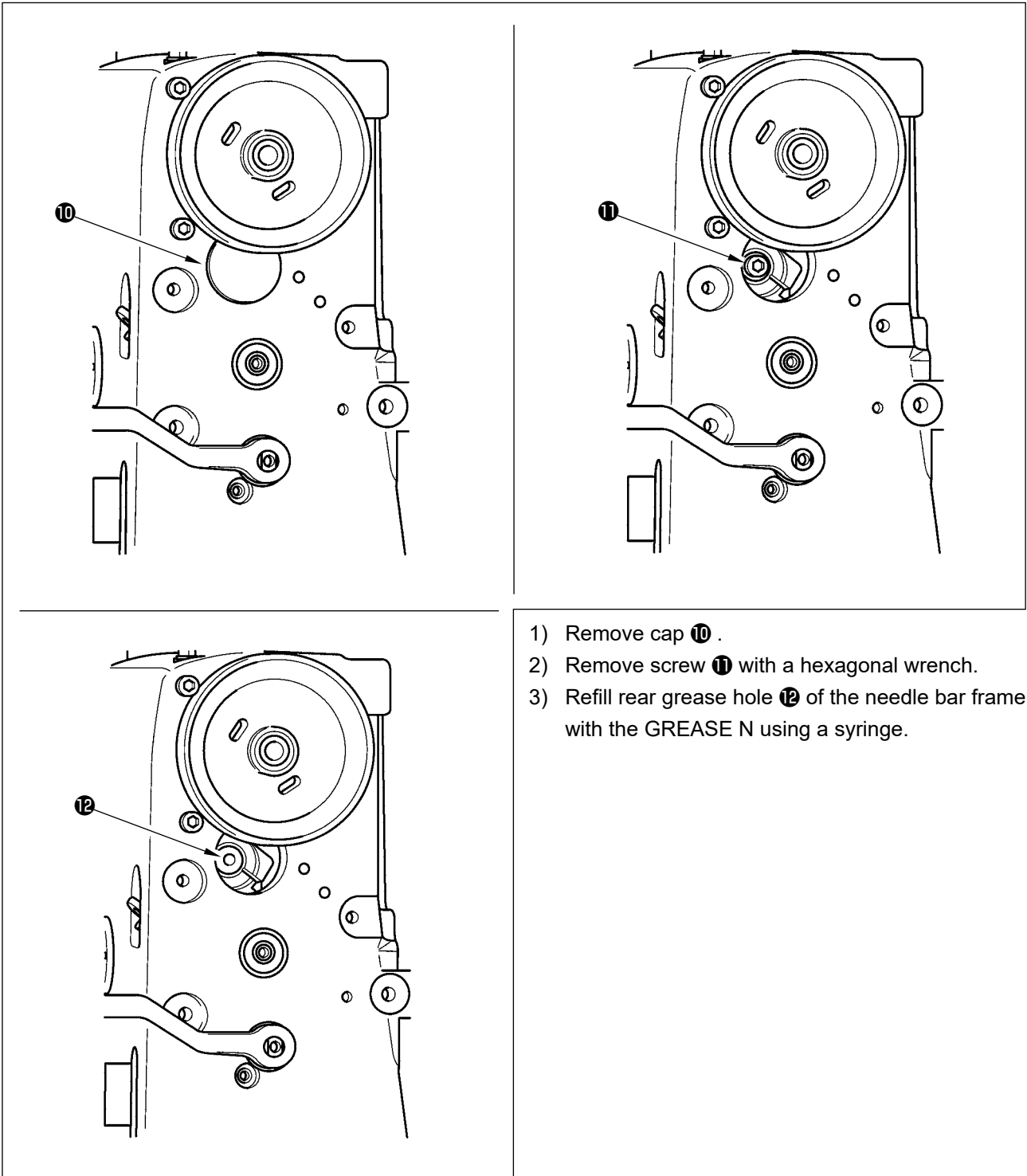

(3) Releasing procedure of the grease-up warning for SC-920

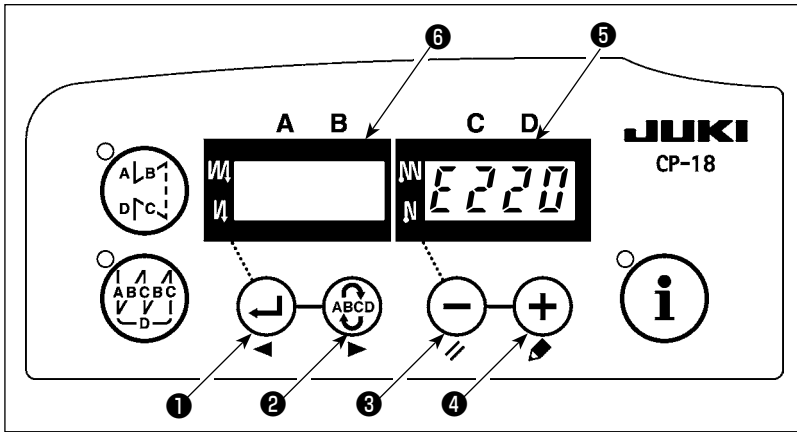

When the time of grease-up has come, screen display of LED ⑤ on the left-hand figure becomes "E220". After performing grease-up, release the warning following the procedure below.



WARNING :

To avoid possible personal injuries caused by movement other than that you desired, do not operate the switches in the procedure other than those required, as described below, to specify the functions.

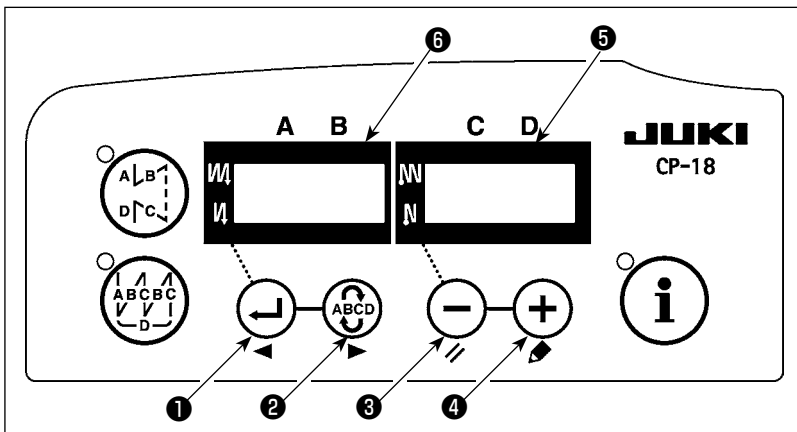

- 1) Turn OFF the power to the unit.
- 2) Pressing switch ④ (+), turn ON the power to the unit.
- 3) When the screen is displayed, keep switch ④ (+) held pressed for three seconds until the buzzer sounds twice.

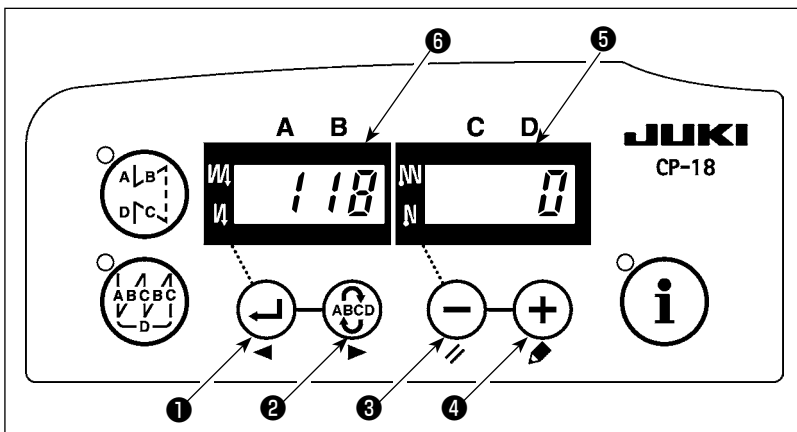

- 4) Set the setting No. ⑥ to "118". When you want to advance the setting No. ⑥, press switch ② (ABCD) to advance the setting No. ⑥. When you want to return the setting No. ⑥, press switch ① (left arrow) to return the setting No. ⑥.



Keep pressing switch ② (ABCD) or switch ① (left arrow), and the setting No. ⑥ will advance (return) continuously. If the setting No. ⑥ is moved forward (or backward), the previous (or subsequent) content of the setting is confirmed. Be careful when the content of a setting is changed (when the up / down switch is touched).

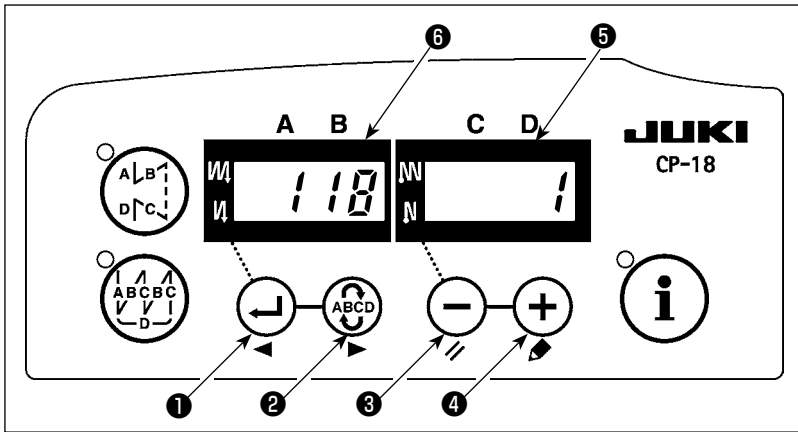

After completion of the operation, turn the power OFF and re-turn it ON to restore the normal operation.

- 5) When setting No. ⑥ is adjusted to "118", the current set value is displayed on LED ⑤. Then Press switch \oplus ④ (switch \ominus ③) to change to "1".
- 6) When the change has been completed, press switch ABCD ② or ABCD ① to specify the changed value.

Caution
When turning OFF the power before performing this work, the contents which have been changed are not updated.

(3) Releasing procedure of the grease-up "error" For SC-920

When using the machine for a certain period of time after the display of error No. 220 (continuing using the machine without performing grease-up at the time of displaying No. 220), error No. 221 is displayed and the machine stops running.

In this case, apply grease to the specified sections, then reset the error according to the description given in **"(3) Releasing procedure of the grease-up warning for SC-920" p.15**

After completion of the operation, turn the power OFF and re-turn it ON to restore the normal operation.

4-7. Setting up the SC-920

(1) Specifications

| | |
|-----------------------|---|
| Supply voltage | 3-phase 200 to 240V |
| Frequency | 50Hz/60Hz |
| Operating environment | Temperature : 0 to 40°C Humidity : 90% or less |
| Input | 320VA |

(2) Installing on the table (LH-3528A-7, 3568A-7, 3578A-7 and 3588A-7)

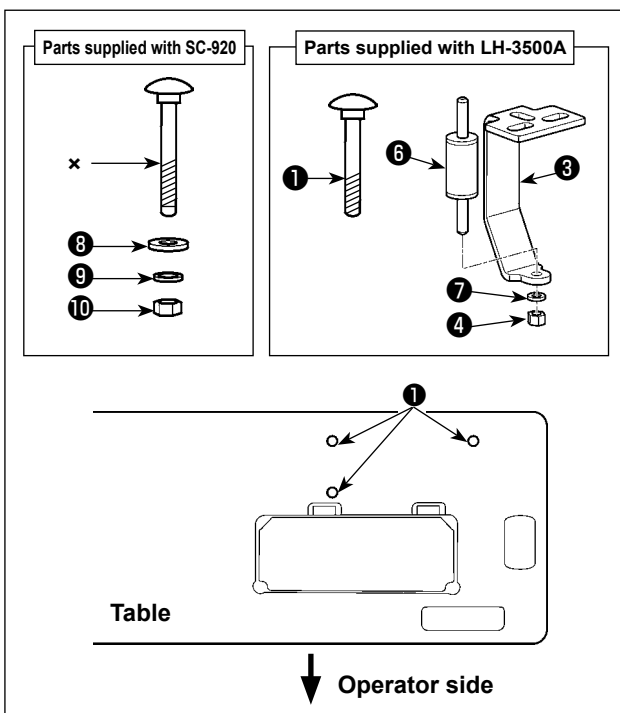

- 1) Hammer decoration bolt ① supplied with the LH-3500A into table.

Caution
The decoration bolt supplied with the SC-920 is not used.

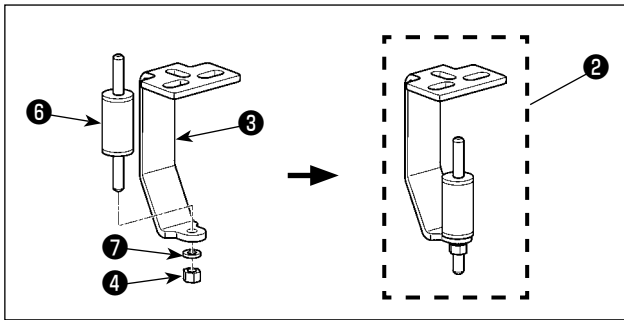

- 2) Fix rubber cushion ⑥ on control-box mounting plate ③ with nut ④ and spring washer ⑦ . Three sets of ② are required.

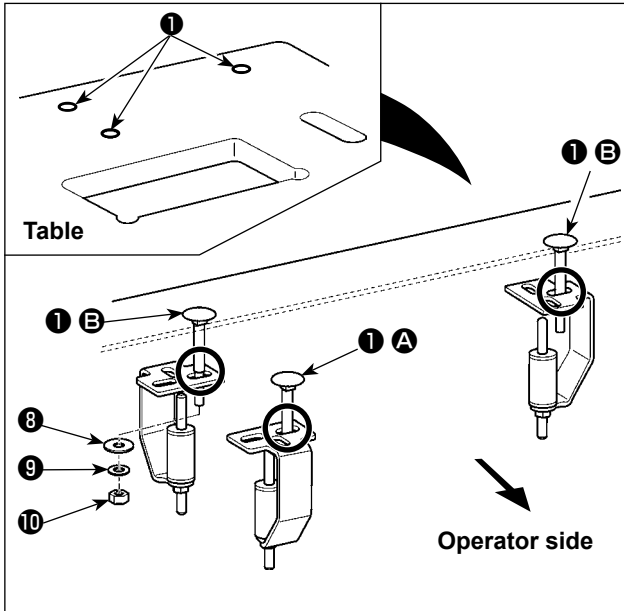

- 3) Fix control-box mounting plates ② assembled in step 2) on the table with decoration bolts ① , washers ⑧ , spring washers ⑨ and nuts ⑩ . Screw ① A at one location this side as observed from the operator should be securely tightened, and two screws ① B at two locations far side from the operator should be temporarily tightened.

- * Install control-box mounting plate ③ as illustrated in the figure, carefully checking the installing direction and the location of holes.
- * The washers, spring washers and nuts supplied with the SC-920 should be used.

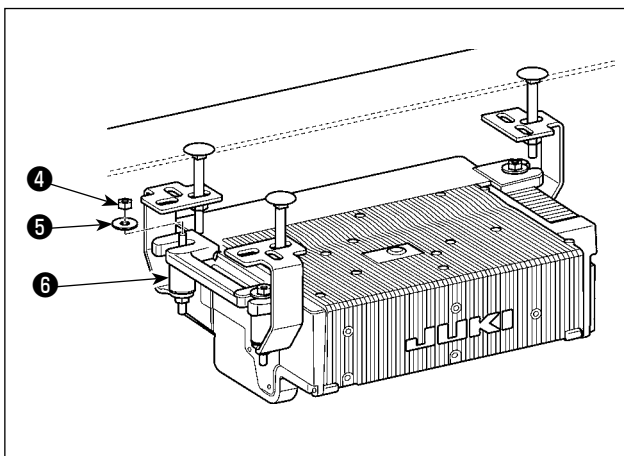

- 4) Place the SC-920 on rubber cushions ⑥ and fix with nuts ④ and washers ⑤ . Install the control box while carefully changing the position of the temporarily-fixed control-box mounting plate (right one as observed from the worker).

1. If you use the decoration bolt supplied with the SC-920, the control box cannot be installed since the bolt interferes with the control box.

2. If the control-box mounting plates are fixed on the table in a wrong installing direction or with the hole located at a wrong position, the control box cannot be installed.

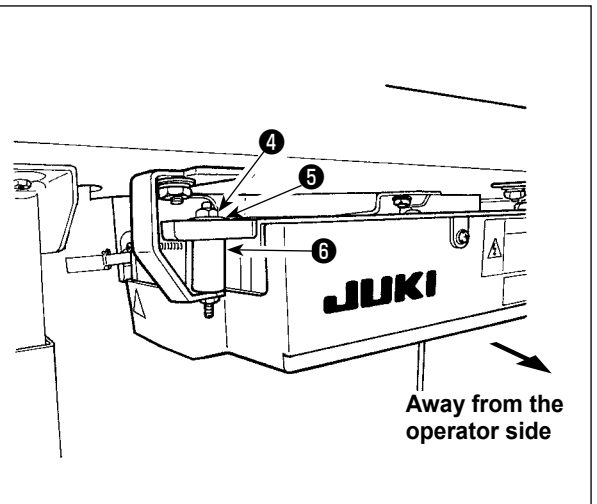
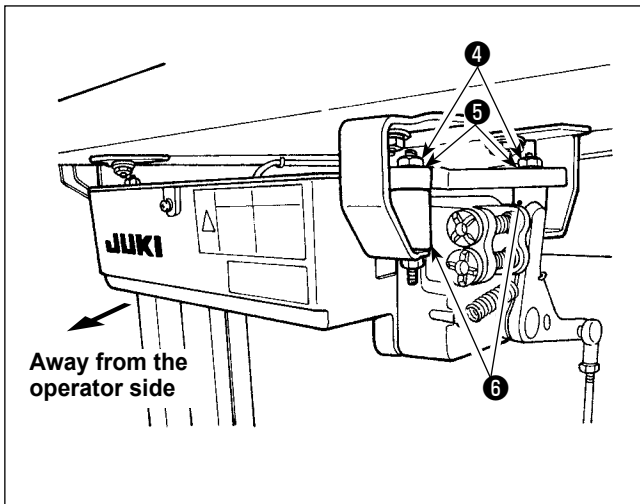

(3) Setting procedure of the machine head



For the operation panel other than CP-18, refer to the Instruction Manual for the operation panel to be used for the setting procedure of the machine head.

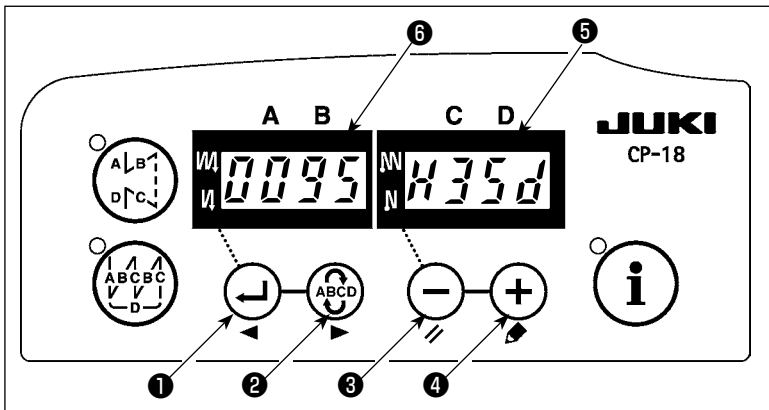

- 1) Call function setting No. 95 referring to "**#-6. Setting functions of SC-920**" in the Instruction Manual for the SC-920.

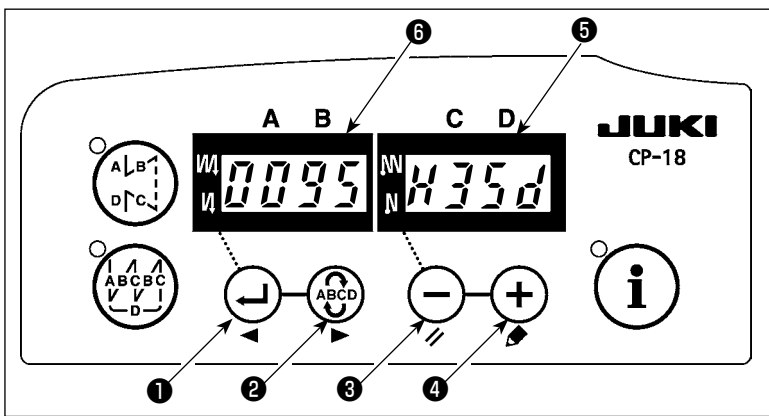

- 2) The type of machine head can be selected by pressing (−) switch ③ (⊕) switch ④).

* Refer to "CAUTIONS WHEN SETTING UP THE SEWING MACHINE" or "Machine head list" on the separate sheet for the types of machine heads.

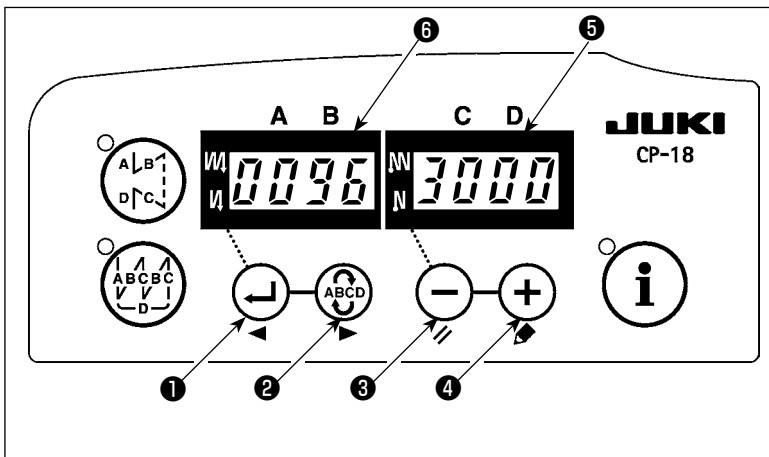

- 3) After selecting the type of machine head, by pressing (←) switch ① (ABCD) switch ②), the step proceeds to 96 or 94, and the display automatically changes to the contents of the setting corresponding with the type of machine head.

(4) Adjusting the machine head (LH-3528A-7, 3568A-7, 3578A-7 and 3588A-7)



When the slip between the white marker dot on the handwheel and the concave of the cover is excessive after thread trimming, adjust the angle of the machine head by the operation below.

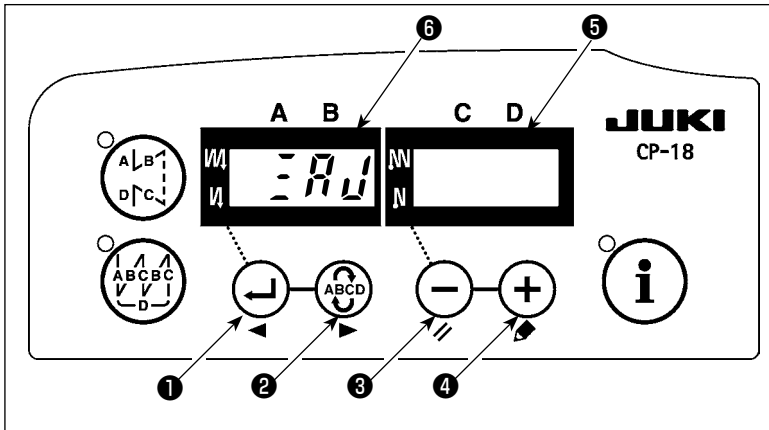

- 1) Simultaneously pressing switch **2** and switch **3**, turn ON the power switch.
- 2) *RU* is displayed (**6**) in the indicator and the mode is changed over to the adjustment mode.

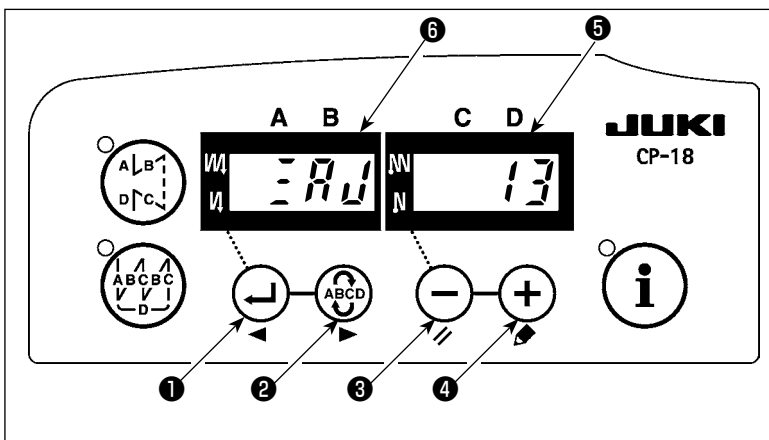

- 3) Turn the pulley of the machine head by hand until the main-shaft reference signal is detected. At this time, the degree of an angle from the main-shaft reference signal is displayed on the indicator **5**. (The value is the reference value.)

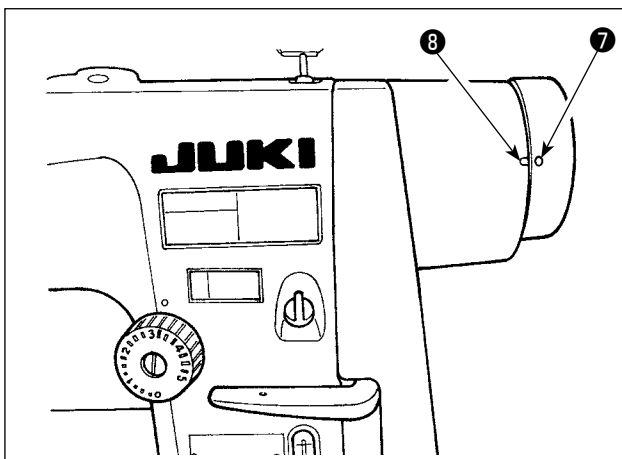

- 4) In this state, align the white dot **7** of the hand-wheel with the concave **8** of the pulley cover as shown in the figure.

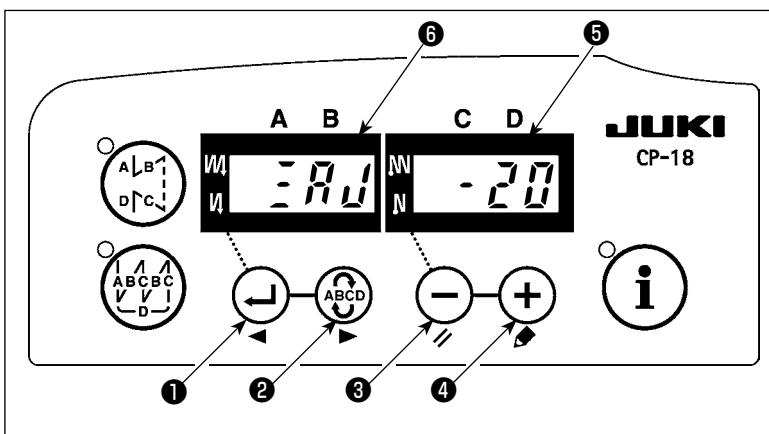

- 5) Press switch **4** to finish the adjustment work. (The value is the reference value.)

4-8. Installing the belt cover (For LH-3528A, 3568A, 3578A and 3588A)



WARNING :

To protect against possible personal injury due to abrupt start of the machine, be sure to start the following work after turning the power off and ascertaining that the motor is at rest.

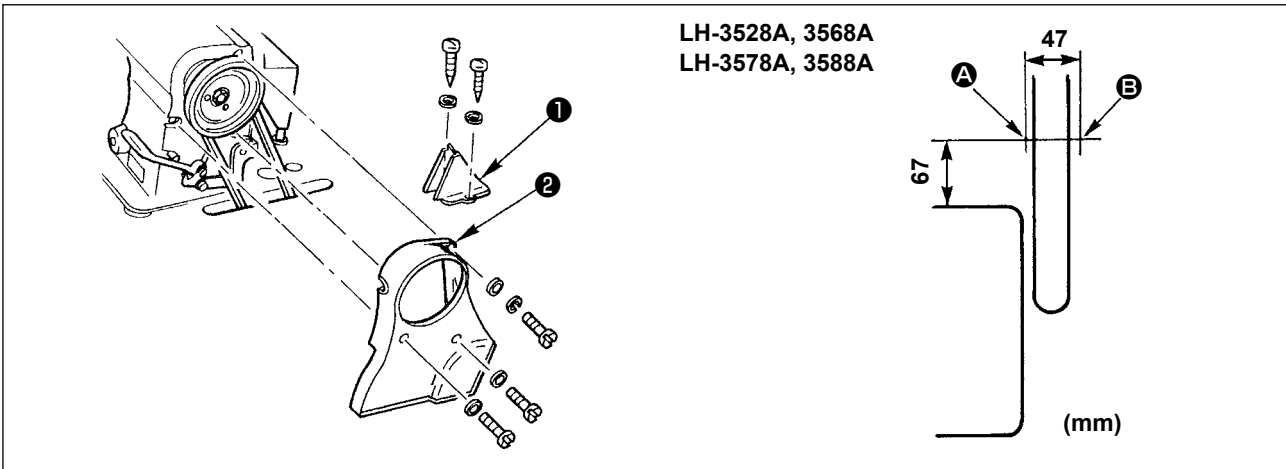

- 1) Drill guide holes **A** and **B** of wood screws in the table.
- 2) Temporarily fix belt cover B **1** to the place of guide holes **A** and **B**.
- 3) Install belt cover A **2** to the arm installing section.
- 4) Adjust the position of belt cover B **1** and fix it with wood screw.

4-9. Attaching the needles



WARNING :

To protect against possible personal injury due to abrupt start of the machine, be sure to start the following work after turning the power off and ascertaining that the motor is at rest.

[LH-3568A, 3568A-7, 3588A and 3588A-7]

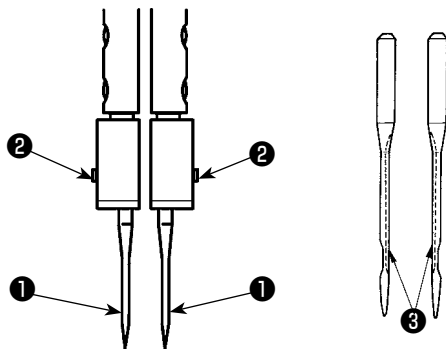

[LH-3528A(A type and F type)]

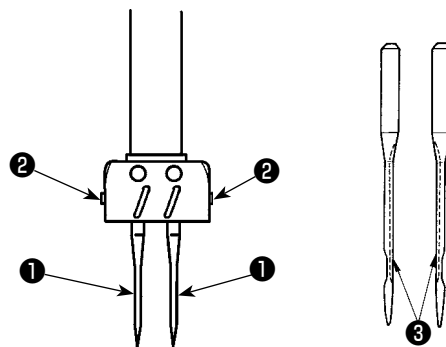

[LH-3528A(S type and G type), 3528A-7, 3578A and 3578A-7]

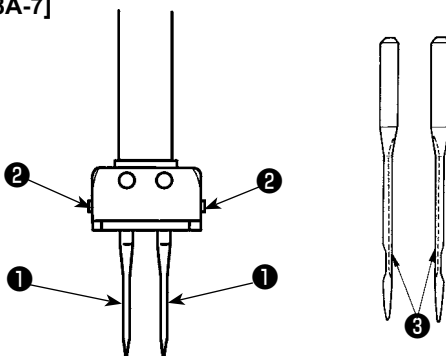

Switch "off" the motor.

Use DPx5(134) needles.

- 1) Turn the handwheel until the needle bar has come up to the highest point of its stroke.
- 2) Loosen needle clamp screws **2** and pick up two needles **1** in the way that their grooves **3** are facing outwards.
- 3) Insert the needles into the needle clamp as far as they will go.
- 4) Tighten needle clamp screws **2** firmly.

4-10. How to take out the bobbin case



WARNING :

To protect against possible personal injury due to abrupt start of the machine, be sure to start the following work after turning the power off and ascertaining that the motor is at rest.

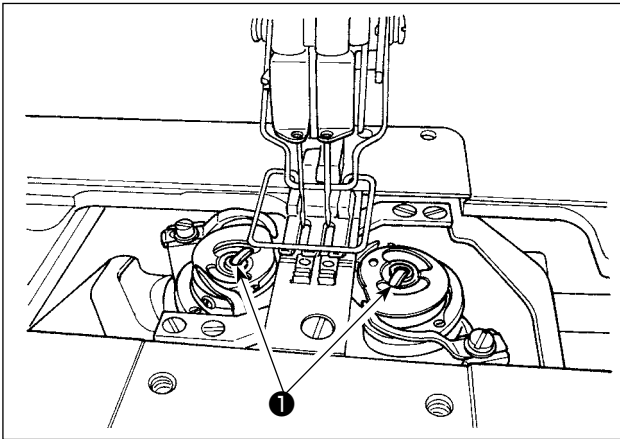

- 1) Lift latch ❶ and take out the bobbin case and the bobbin together.
- 2) Hold the bobbin case by latch raised, put it into the shaft in the hook correctly and release the latch.

4-11. Inserting a bobbin in a bobbin case



WARNING :

To protect against possible personal injury due to abrupt start of the machine, be sure to start the following work after turning the power off and ascertaining that the motor is at rest.

[LH-3568A, 3568A-7, 3588A and 3588A-7]

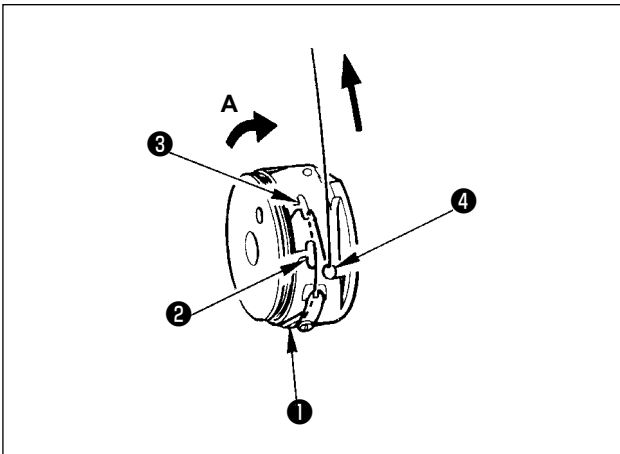

- 1) Set a bobbin to the bobbin case so that the bobbin turns in the direction of arrow mark **A**.
- 2) Pass the thread through thread slit ❶ in the bobbin case and draw the thread and pull the thread so that it passes under the tension spring.
- 3) Pass thread through another thread slit ❷ then, pass it through thread slit ❸ on the bobbin case from the inside.
- 4) Put the thread on bobbin threads slack preventer spring ❹ .

[LH-3528A, 3528A-7, 3578A and 3578A-7]

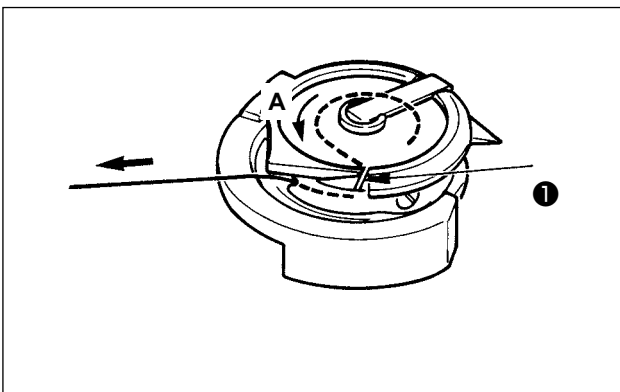

- 1) Set a bobbin to the bobbin case so that the bobbin turns in the direction of arrow mark **A**.
- 2) Pass the thread through thread slit ❶ in the hook and draw the thread and pull it so that it passes under the tension spring.

4-12. Threading the machine head

[S type and G type] LH-3528A, 3528A-7, 3568A and 3568A-7



WARNING :

To protect against possible personal injury due to abrupt start of the machine, be sure to start the following work after turning the power off and ascertaining that the motor is at rest.

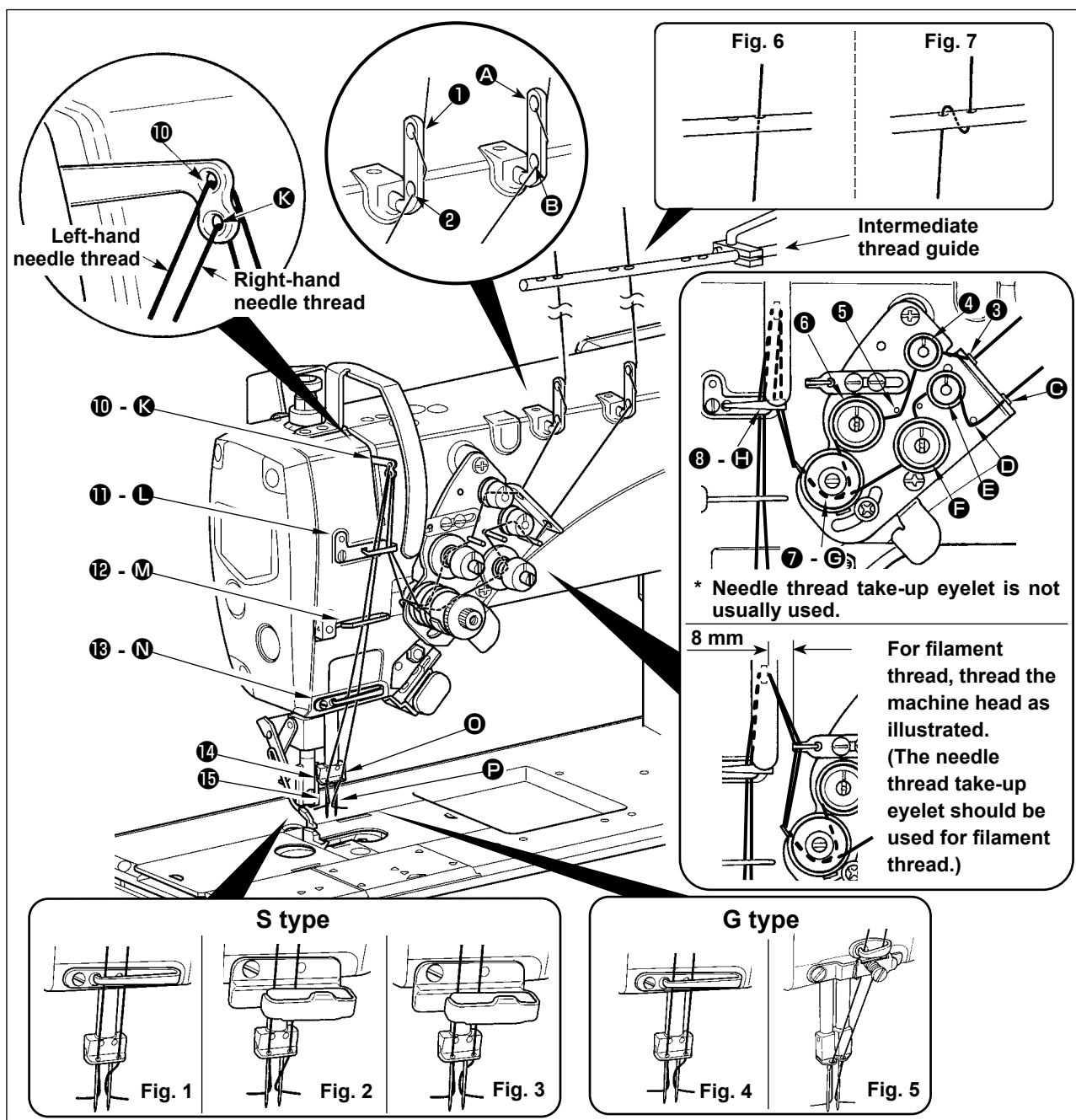

Thread the machine head following the order as illustrated in the figure.

Pass the left-hand needle thread, toward the machine head, in the order of ① to ⑮. Pass the right-hand needle thread in the order of ① to ⑰.

1. Carefully check how to thread the needle clamp thread guides (⑭, ⑯).

· (S type) See Fig 1 for polyester spun thread, Fig. 2 for thick filament thread of yarn count #50 or lower and around #50, or Fig 3 for thin filament thread of yarn count #50 or higher.

· (G type) See Fig. 4 for thick thread of yarn count #5 to #30.



2. When using filament thread for sewing, use the felt thread guides supplied with the sewing machine. If the needle thread loosens or breaks, take some preventive measure such as winding the thread on the needle (S type).

3. To produce chain-off thread, the felt thread guide (in Fig. 2 or Fig. 3) should be used for the S type, or the needle thread presser (in Fig. 5) should be used for the G type.

4. For the LH-3528A-7 or LH-3568A-7, thread the intermediate thread guide as follows:

· For polyester spun thread, see Fig. 6. For filament thread, see Fig. 7.

[G type] LH-3578A, 3578A-7, 3588A and 3588A-7



WARNING :

To protect against possible personal injury due to abrupt start of the machine, be sure to start the following work after turning the power off and ascertaining that the motor is at rest.

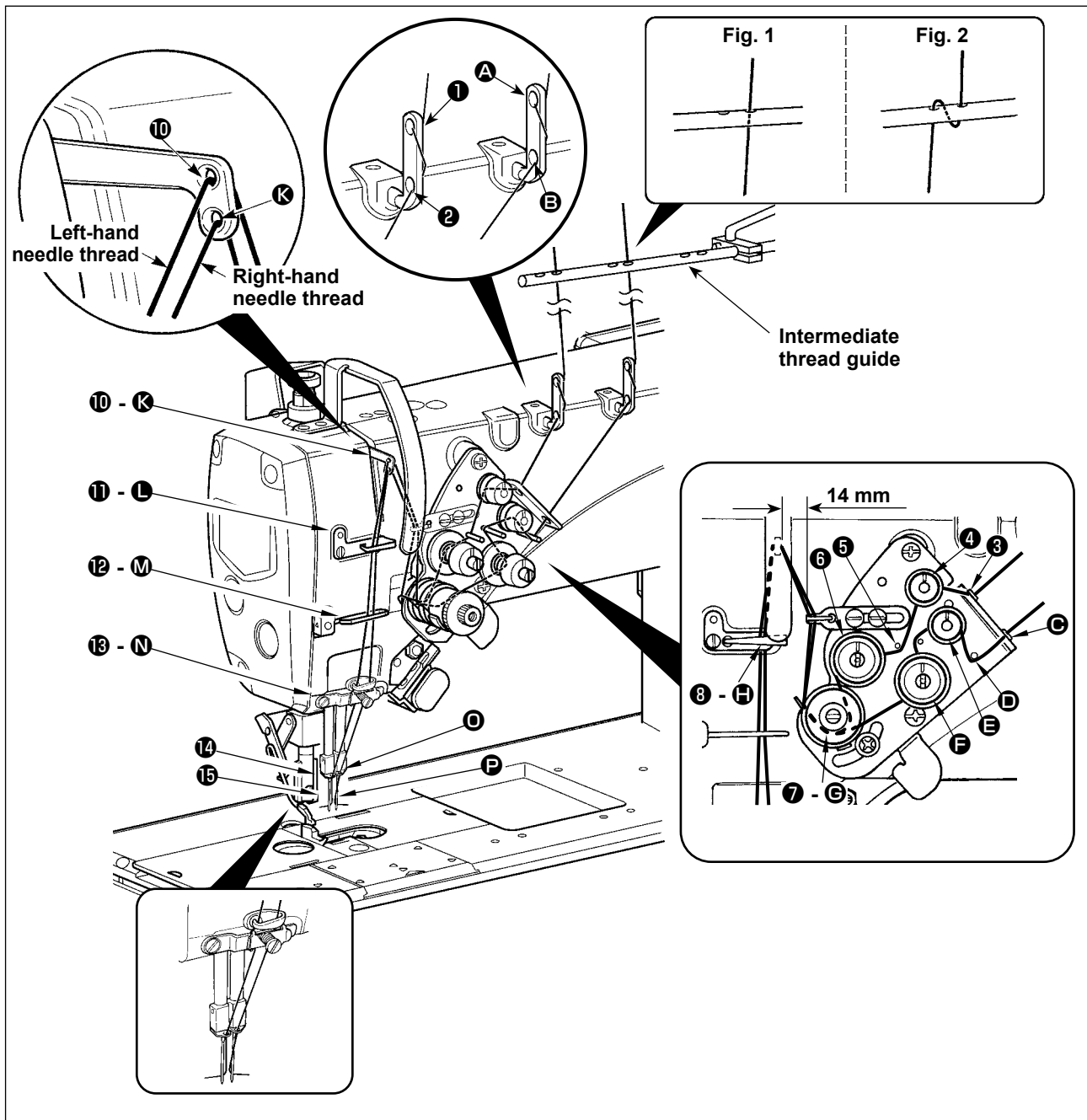

Thread the machine head following the order as illustrated in the figure.

Pass the left-hand needle thread, toward the machine head, in the order of ① to ⑮. Pass the right-hand needle thread in the order of ① to ⑰.



1. Thread guide (⑫, ⑭) is able to prevent the needle thread from flapping according to its inclination. If the thread guide is inclined excessively, the needle thread can tangle on thread guide (⑬, ⑮). So, carefully adjust the inclination of the thread guide.
2. For the LH-3578A-7 or LH-3588A-7, thread the intermediate thread guide as follows:
 - For polyester spun thread, see Fig. 1. For filament thread, see Fig. 2.

[A type and F type]



WARNING :

To protect against possible personal injury due to abrupt start of the machine, be sure to start the following work after turning the power off and ascertaining that the motor is at rest.

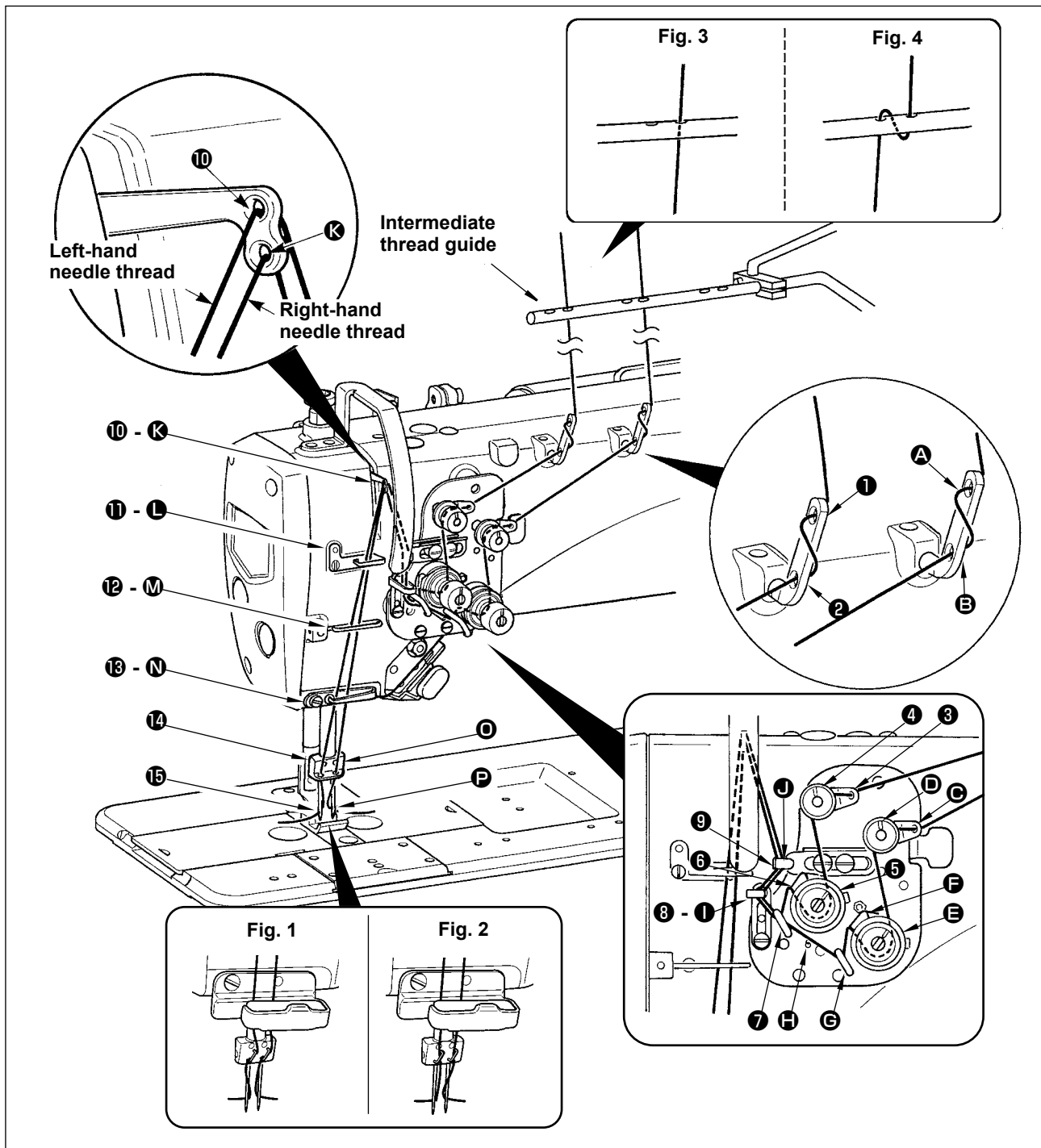

Thread the machine head following the order as illustrated in the figure.

Pass the left-hand needle thread, toward the machine head, in the order of ① to ⑮ . Pass the right-hand needle thread in the order of A to F.



1. Be careful of threading of needle clamp thread guides (⑭ , ⑯).
 · See Fig. 1 for thin filament thread of yarn count #50 or higher, and Fig. 2 for thick filament thread of yarn count #50 or lower, filament thread around yarn count #50 and polyester spun thread.
2. Pass right-side needle thread through the upper side of thread guide pin ④.
3. Pass the thread through the intermediate thread guide of LH-3528A-7 and 3568A-7 as follows.
 · Fig. 3 for polyester spun thread. Fig. 4 for filament thread.

4-13. Thread tension



WARNING :

To protect against possible personal injury due to abrupt start of the machine, be sure to start the following work after turning the power off and ascertaining that the motor is at rest.

[S type and G type]

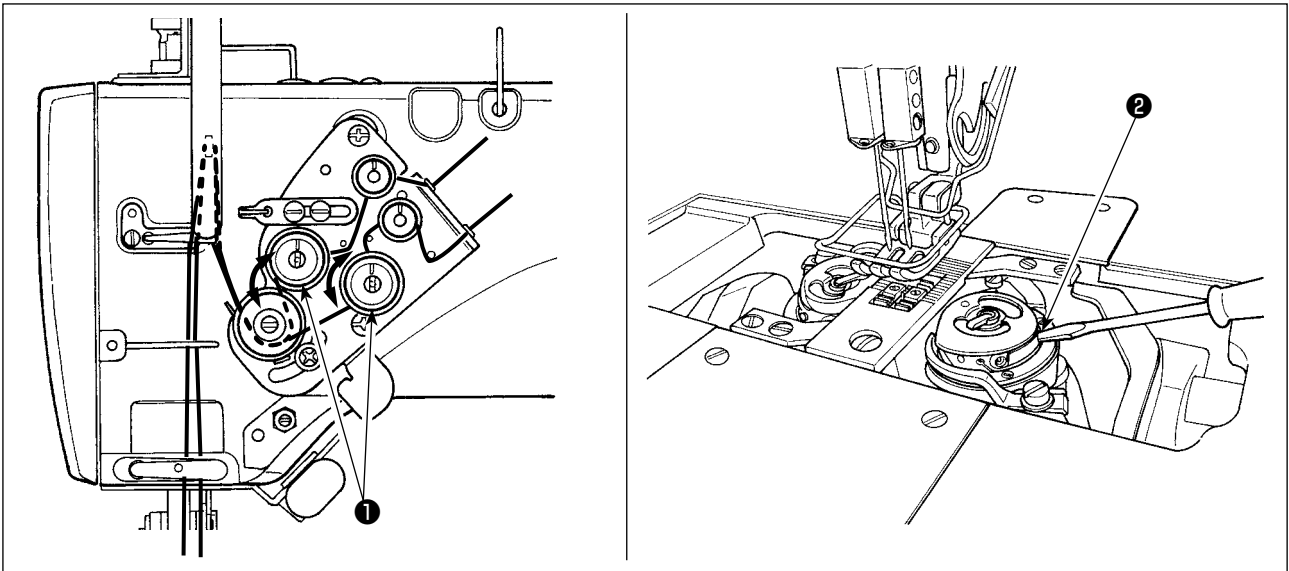

[A type and F type]

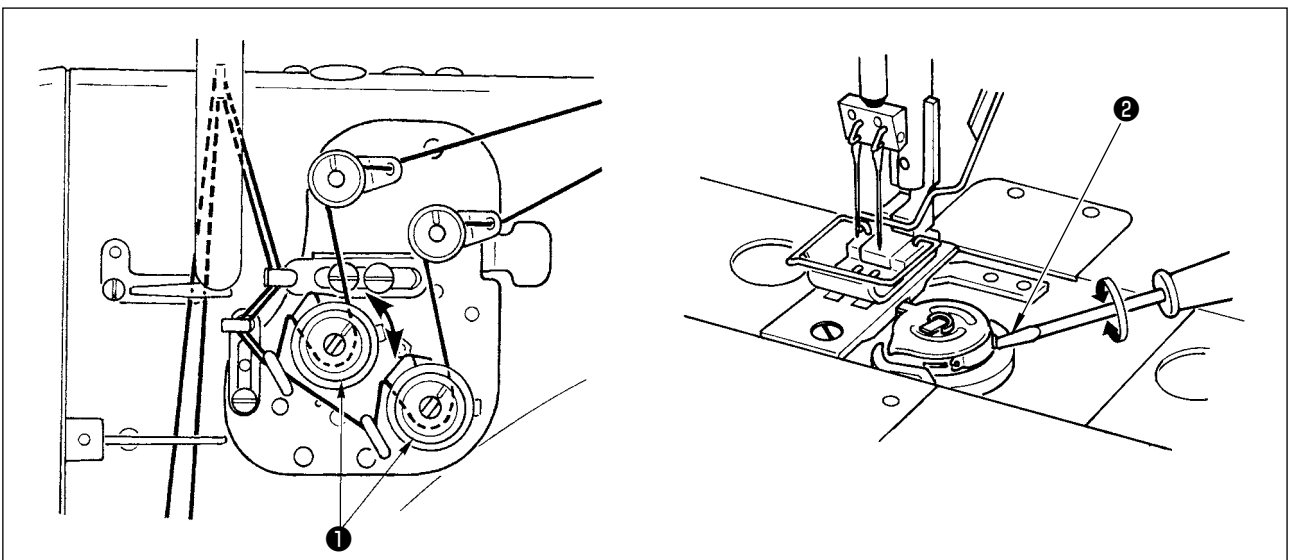

1) Needle thread tension

Turn thread tension nut No. 2 **1** clockwise to increase or counterclockwise to reduce the needle thread tension.

2) Bobbin thread tension

Turn tension adjusting screw **2** clockwise to increase or counterclockwise to reduce the bobbin thread tension.

4-14. Winding the bobbin thread

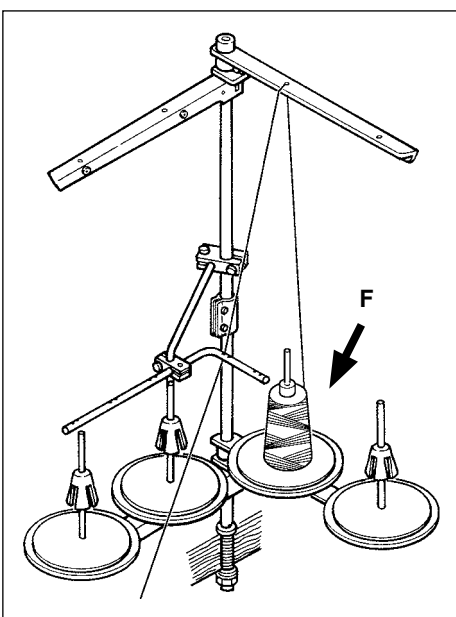
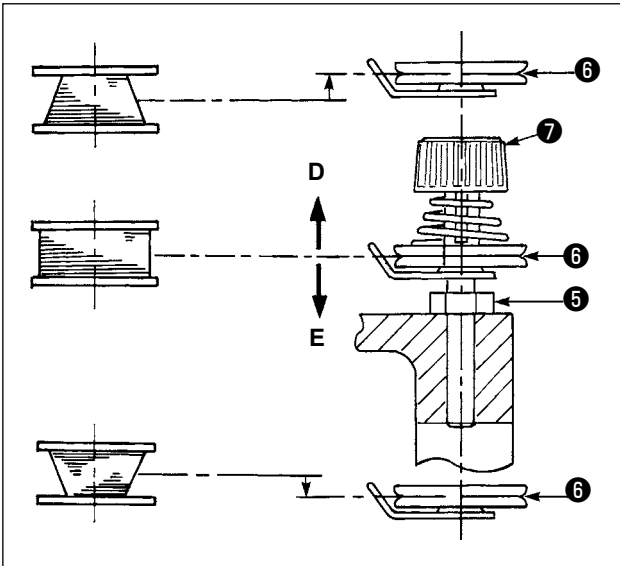
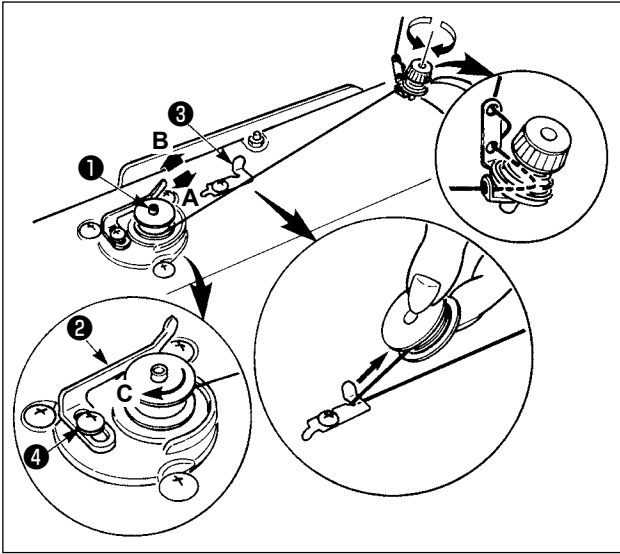

- 1) Insert the bobbin deep into the bobbin winder spindle ① until it will go no further.
- 2) Pass the bobbin thread pulled out from the spool rested on the right side of the thread stand following the order as shown in the figure on the left. Then, wind clockwise the end of the bobbin thread on the bobbin several times. (In case of the aluminum bobbin, after winding clockwise the end of the bobbin thread, wind counterclockwise the thread coming from the bobbin thread tension several times to wind the bobbin thread with ease.)
- 3) Press the bobbin winder trip latch ② in the direction of A and start the sewing machine. The bobbin rotates in the direction of C and the bobbin thread is wound up. The bobbin winder spindle ① automatically as soon as the winding is finished.
- 4) Remove the bobbin and cut the bobbin thread with the thread cut retainer ③.
- 5) When adjusting the winding amount of the bobbin thread, loosen setscrew ④ and move bobbin winding lever ② to the direction of A or B. Then tighten setscrew ④.
 - To the direction of A : Decrease
 - To the direction of B : Increase
- 6) When the bobbin is not evenly wound with thread, loosen nut ⑤ and adjust the height of bobbin winder tension disk ⑥.
 - It is the standard that the center of the bobbin is as high as the center of thread tension disk ⑥.
 - Adjust the position of thread tension disk ⑥ to the direction of D when the winding amount of the bobbin thread on the lower part of the bobbin is excessive and to the direction E when the winding amount of the bobbin thread on the upper part of the bobbin is excessive.
- After the adjustment, tighten nut ⑤.
- 7) To adjust the tension of the bobbin winder, turn the thread tension nut ⑦.

- Caution**

 1. When winding the bobbin thread, start the winding in the state that the thread between the bobbin and thread tension disk ⑥ is tense.
 2. When winding the bobbin thread in the state that sewing is not performed, remove the needle thread from the thread path of thread take-up and remove the bobbin from the hook.
 3. There is the possibility that the thread pulled out from the thread stand is loosened due to the influence (direction) of the wind and may be entangled in the handwheel. Be careful of the direction of the wind.
 4. Slackened part of the thread can get tangled on the pulley. It is recommended, in order to avoid the above-stated trouble, to wind the bobbin on the F side which is located far from the motor.

4-15. Thread take-up spring



WARNING :

To protect against possible personal injury due to abrupt start of the machine, be sure to start the following work after turning the power off and ascertaining that the motor is at rest.

[S type and G type]

(1) When you want to change the stroke of the thread take-up spring

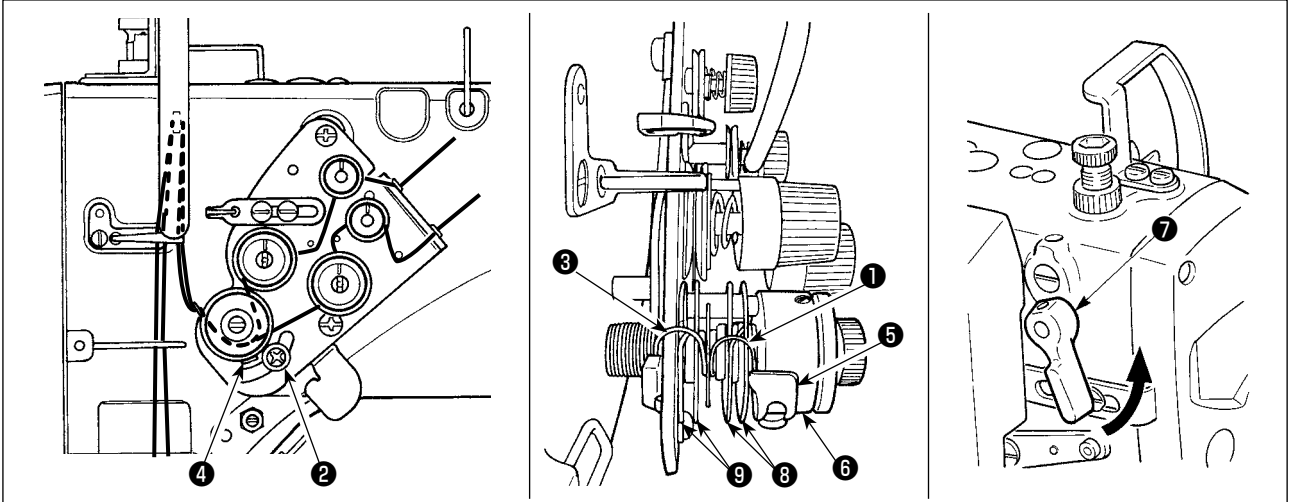

- 1) For thread take-up spring ③ on the left side, loosen screw ② and adjust the stroke of the spring by moving the screw along the slot for adjustment.
- 2) For thread take-up spring ① on the right side, loosen screw ④ and adjust the stroke of the spring by moving thread take-up spring adjusting plate ⑤ along thread take-up spring base ⑥ .



In addition, for LH-3528A, 3528A-7, 3578A and 3578A-7, make sure that thread tension disks ⑧

and ⑨ securely rise when hand lifter lever ⑦ is turned in the direction of the arrow.

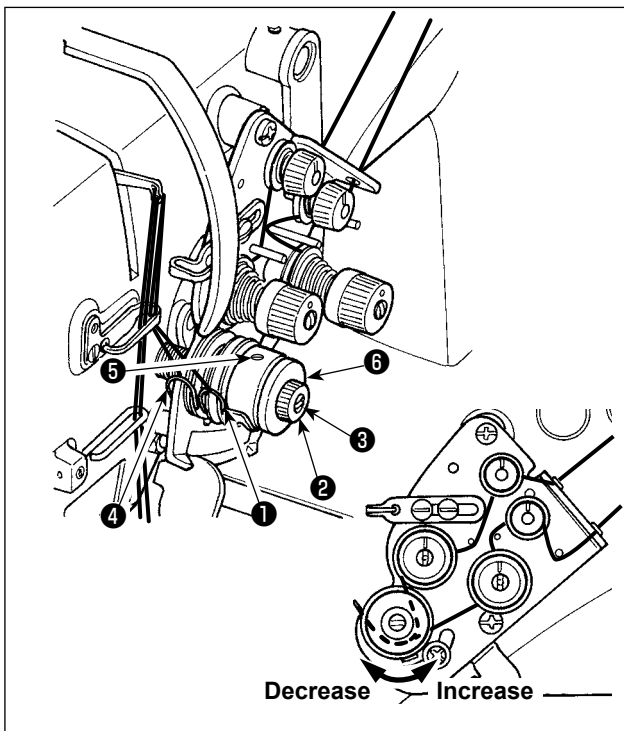

(2) When you want to change the tension of the thread take-up spring

- 1) To change the tension of thread take-up spring ④ on the left side, loosen nut ② and turn spring stud ③ clockwise to increase or counterclockwise to decrease the tension of the spring. After the adjustment, fix the stud by tightening nut ② .
- 2) To change the tension of thread take-up spring ① on the right side, loosen screw ⑤ and turn nut ⑥ clockwise to increase or counterclockwise to decrease the tension of the spring. After the adjustment, fix nut by tightening screw ⑤ .

[A type and F type]

(1) When you want to change the stroke of the thread take-up spring

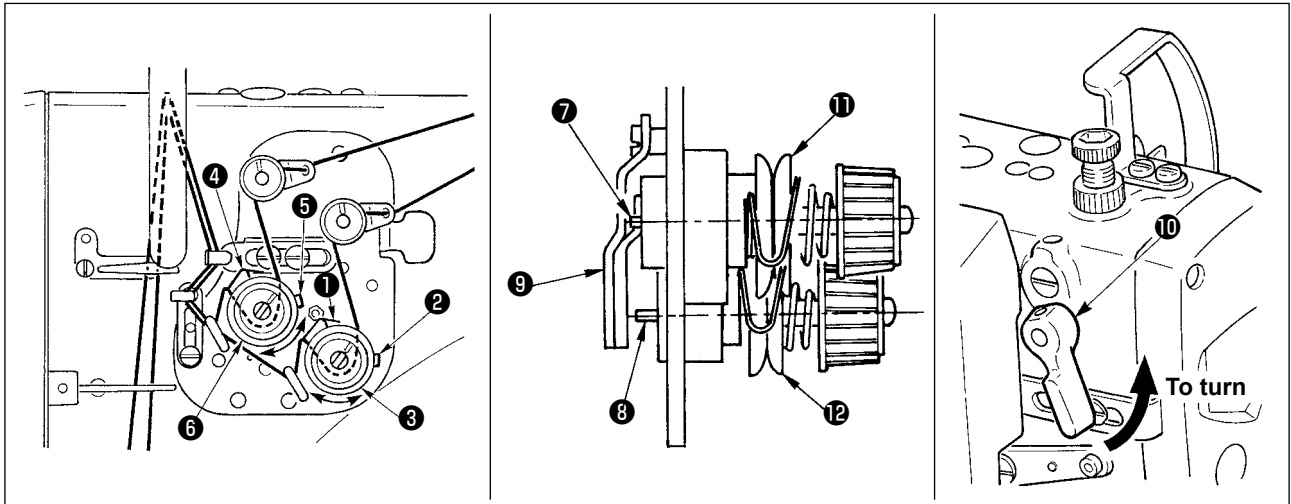

- 1) Stroke of thread take-up spring ① on the right is adjustable by moving thread tension No. 2 asm. ③ to the left or right after loosening thread tension No. 2 setscrew ② .
- 2) Stroke of thread take-up spring ④ on the left is adjustable by moving thread tension No. 2 asm. ⑥ to the left or right after loosening thread tension No. 2 setscrew ⑤ .
- 3) Move thread tension No. 2 asm. ③ and ⑥ to the right to increase or to the left to decrease the stroke of the thread take-up spring.



When adjusting the stroke of thread take-up springs ① and ④ , thread release pins ⑦ and ⑧ should not come in contact with disk release plate ⑨ .

In addition, for LH-3528A, 3528A-7 make sure that thread tension disks ⑪ and ⑫ securely rise when hand lifter lever ⑩ is turned in the direction of the arrow.

(2) When you want to change the tension of the thread take-up spring

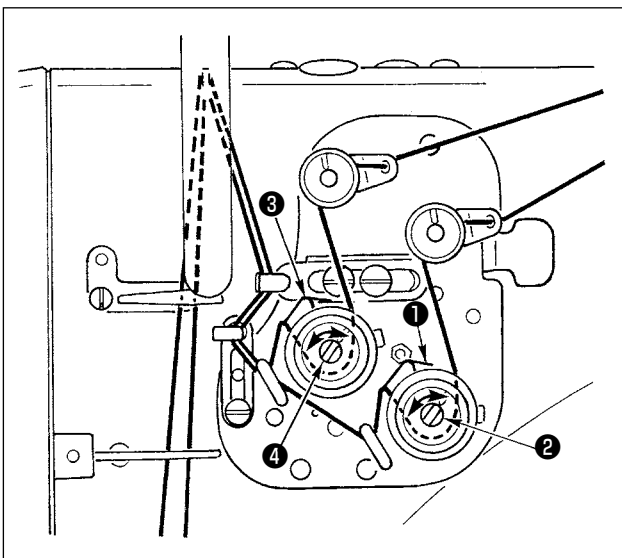

- 1) Tension of thread take-up spring ① on the right is adjustable by turning spring stud ② to the right to increase or to the left to reduce.
- 2) Tension of thread take-up spring ③ on the left is adjustable by turning spring stud ④ to the right to increase or to the left to reduce.

4-16. Adjusting the stitch length

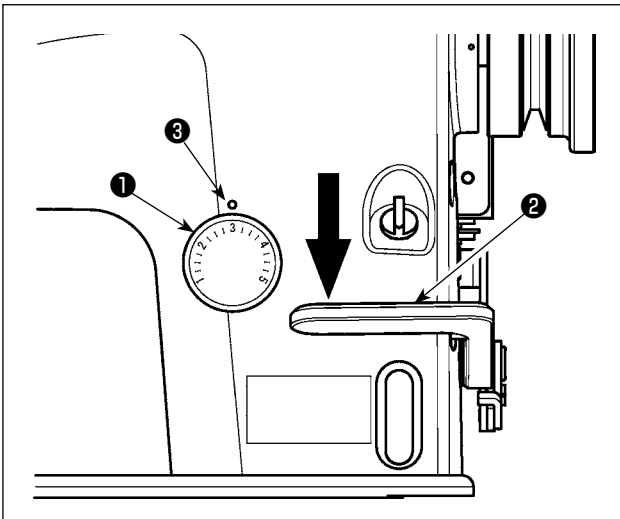

Turn stitch dial ❶ counterclockwise (clockwise) to set the value on the dial corresponding to a desired stitch length to the marker dot ❸ engraved on the machine arm.

When it is hard to turn stitch dial ❶, turn it while slightly depressing reverse feed control lever ❷.

• Reverse feed operation

- 1) Depress reverse feed control lever ❷.
- 2) Reverse stitches are made as long as you keep depressing the lever.
- 3) Release lever, and the machine will run forward.

4-17. Needle-to-hook relation



WARNING :

To protect against possible personal injury due to abrupt start of the machine, be sure to start the following work after turning the power off and ascertaining that the motor is at rest.

[LH-3528A, 3528A-7, 3578A and 3578A-7]

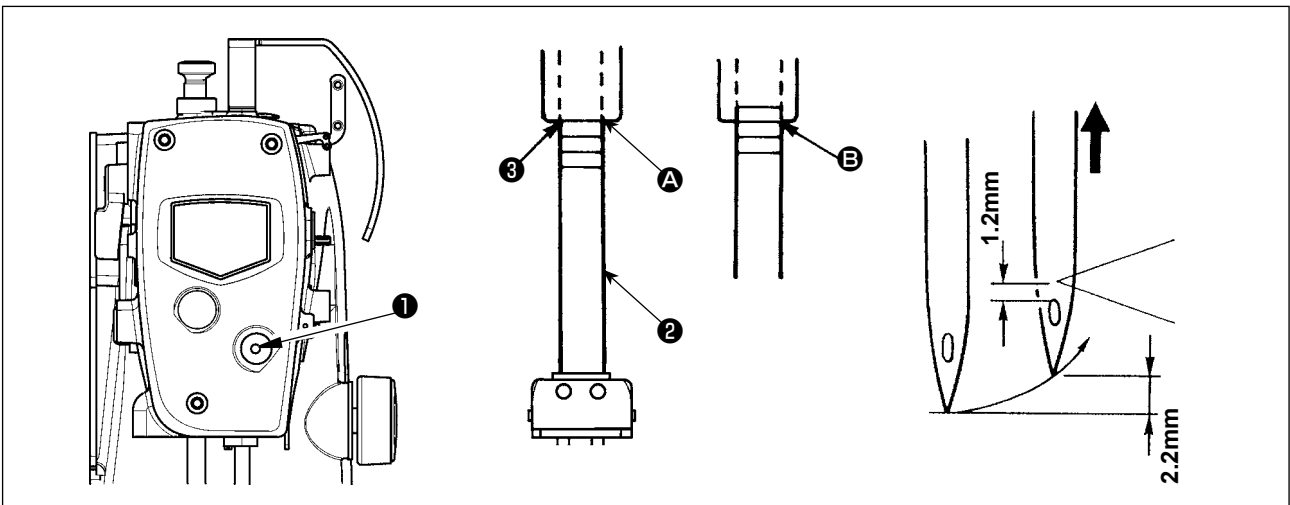

• Adjust the needle and the hook as follows.

- 1) Set the stitch dial at 2 for the A or F type, 2.5 for the S type or 3 for the G type.
- 2) Turn the handwheel to bring the needle bar to the lowest position and loosen needle bar connecting stud clamping screw ❶.
- 3) Determine the height of needle bar. The upper two of engraved marker lines are for DPx5(134) needle, and the lower two of them are for DP X 17(135x17) needle.

[Adjusting procedure for DPx5(134) needle]

Adjust top engraved marker line A of needle bar ❷ to the bottom end of needle bar rocking base ❸, and tighten the needle bar connecting stud clamping screw ❶. At this time, the needle bar goes up by 2.2 mm from the lowest position (adjust the second engraved marker line B to the bottom end of needle bar rocking base ❸) and the blade point of hook aligns with the center of needle. Then the distance between the top end of needle eyelet and the blade point of hook becomes 1.2 mm.

[Adjusting procedure for DP X 17(135x17) needle]

Use the lower two of the engraved marker lines, and perform the adjustment by the same procedure as that of [Adjusting procedure for DPx5(134) needle].

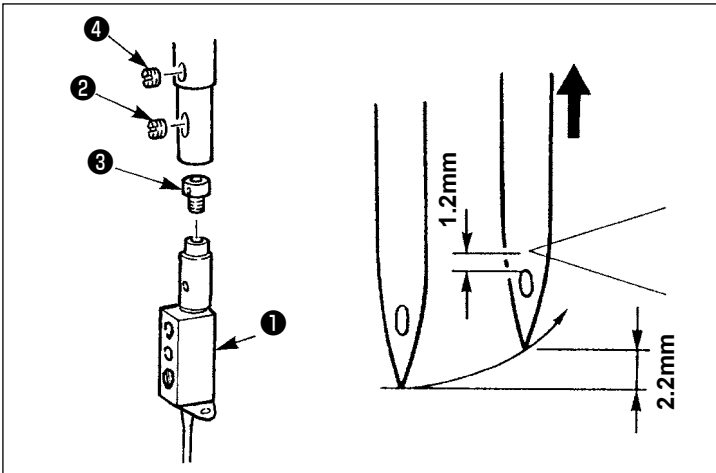

• Adjust the needle and the hook as follows.
[Adjusting procedure for DPx5(134) needle]

- 1) Set the stitch dial at 2.5 for the S type or 3 for the G type.
- 2) Turn the handwheel to align the blade point of hook with the center of needle when the needle bar goes up by 2.2 mm from the lowest position (lower engraved marker line of the needle bar aligns with the bottom end of the needle bar rocking base). At this time, it is the standard that the distance between the top end of needle eyelet and the blade point of hook becomes 1.2 mm.

- 3) If the needle-to-hook relation is different from the afore-mentioned standard adjustment, remove needle clamp screw ② and turn needle clamp ① by one revolution (the extent of adjustment : 0.6mm). The needle-to-hook relation can also be adjusted by removing screw ④ from the spring shoe and turning spring shoe ③ by a half revolution (the extent of adjustment : 0.3mm).

[Adjusting procedure for DP X 17(135x17) needle]

When replacing the needle with DP X 17(135x17), replace needle clamp ① . (Needle clamp for DP X 17(135x17) is an optional part.) Use the same engraved marker line of the needle bar for DPx5(134). Adjusting procedure is the same as that of DPx5(134).

[Common]

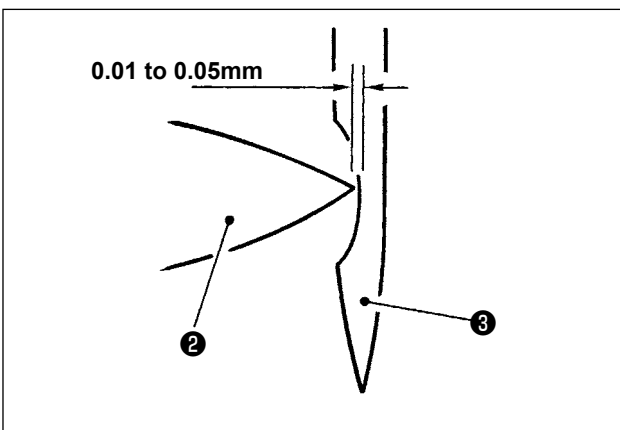
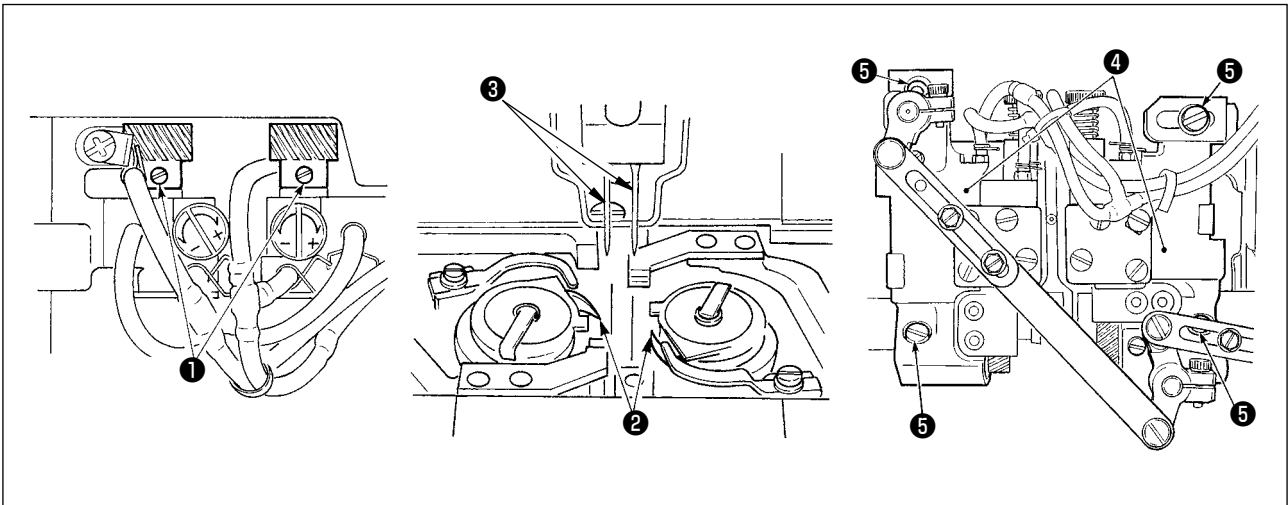

• Determine the position of the hook.

- 1) Loosen three setscrews ① in the screw gear (small), and turn the handwheel to lift the needle bar from its lowest position by 2.2 mm.
- 2) In this state, loosen four setscrews ⑤ in hook driving shaft saddle ④ , and move hook driving shaft saddle ④ to the right or left to adjust so that a clearance of 0.01 to 0.05 mm is provided between blade point ② of the hook and needle ③ . Then tighten setscrews ⑤ .
- 3) Next, in the state described in step 1), align the blade point of hook with the center of needle and tighten setscrews ① in the screw gear (small).

4-18. Pedal pressure and pedal stroke



WARNING :

To protect against possible personal injury due to abrupt start of the machine, be sure to start the following work after turning the power off and ascertaining that the motor is at rest.

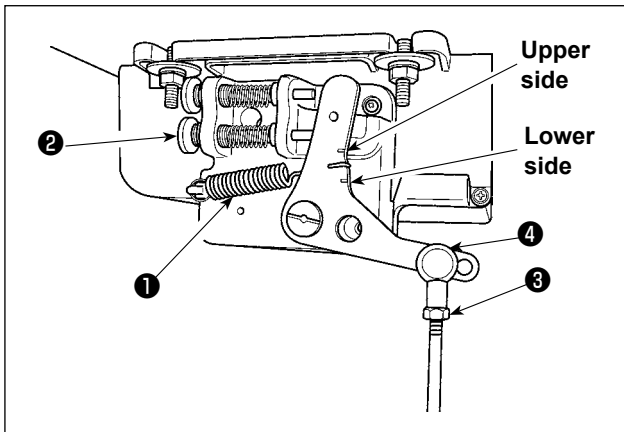

(1) Adjusting the pressure required to depress the front part of the pedal

When the pedal pressure spring ① is hooked to the lower side, the pedal pressure will decrease, and when hooked to the upper side, the pedal pressure will increase.

(2) Adjusting the pressure required to depress the back part of the pedal

The pressure increases as you turn reverse depressing regulator screw ② in, and decreases as you turn the screw out.

(3) Adjusting the pedal stroke

The pedal stroke decreases when you insert connecting rod ③ into the left hole ④ .

4-19. Adjustment of the pedal



WARNING :

To protect against possible personal injury due to abrupt start of the machine, be sure to start the following work after turning the power off and ascertaining that the motor is at rest.

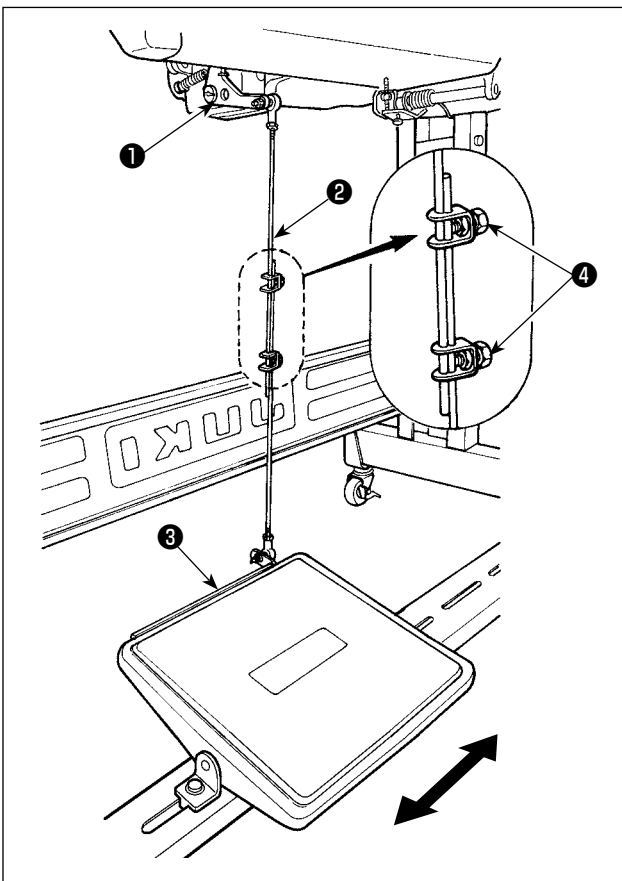

(1) Installing the connecting rod

1) Move pedal ③ to the right or left as illustrated by the arrows so that motor control lever ① and connecting rod ② are straightened.

(2) Adjusting the pedal angle

1) The pedal tilt can be freely adjusted by changing the length of the connecting rod.
2) Loosen adjust screw ④ , and adjust the length of connecting rod ② .

5. OPERATION OF THE SEWING MACHINE

5-1. Pedal Operation

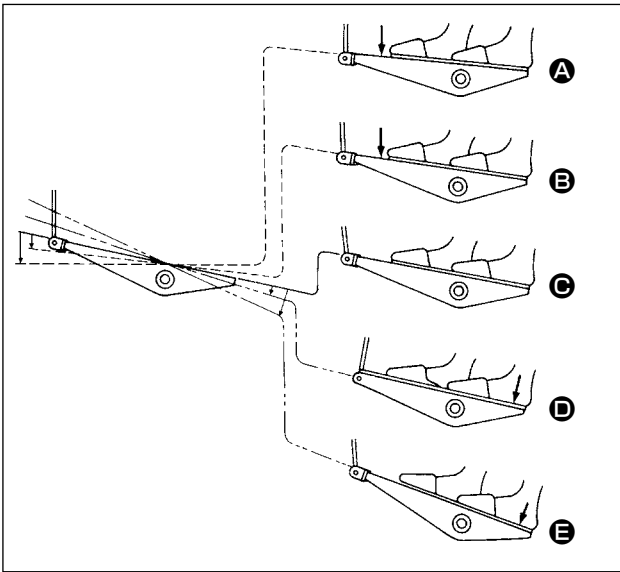

[The pedal is operated in the following four steps:]

- 1) The machine runs at low sewing speed when you lightly depress the front part of the pedal. **B**
- 2) The machine runs at high sewing speed when you further depress the front part of the pedal. **A** (If the automatic reverse feed stitching has been preset, the machine runs at high speed after it completes reverse feed stitching.)
- 3) The machine stops (with its needle up or down) when you reset the pedal to its original position. **C**
- 4) The machine trims threads when you fully depress the back part of the pedal. **E**

- * When auto-lifter (AK135) is used, 1-step switch is increased between stop and thread trimming. The presser foot goes up when the back part of the pedal is lightly depressed **D**, and the presser foot comes down once when the back part of the pedal is further strongly depressed. Then the thread trimmer is actuated and the presser foot goes up again.
- If you reset the pedal to its neutral position during the automatic reverse feed stitching at seam start, the machine stops after it completes the reverse feed stitching.
 - The machine will perform normal thread trimming even if you depress the back part of the pedal immediately following high or low speed sewing.
 - The machine will completely perform thread trimming even if you reset the pedal to its neutral position immediately after the machine started thread trimming action.

5-2. Hand lifter

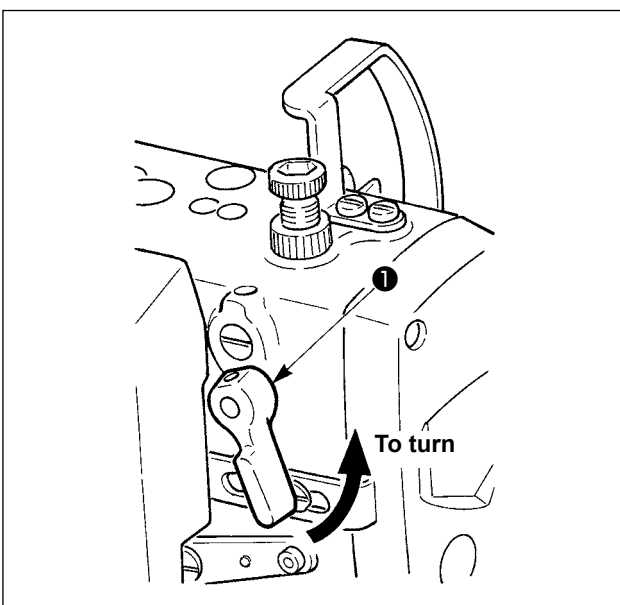

- 1) When you want to keep the presser foot in the lifted position, turn hand lifter **1** in the direction of the arrow. By so doing, the presser foot rises 7 mm.
- 2) When you want to lower the presser foot, lower the hand lifter. This will return the presser foot to its predetermined lower position.
- 3) Operate the knee lifter, and the presser will rise by approximately 13 mm.



Never perform thread trimming operation with the presser foot lifted since there is a case where the wiper comes in contact with the presser foot and the needle may be broken when the sewing machine is operated with the presser foot lifted.

5-3. Adjusting the pressure of the presser foot

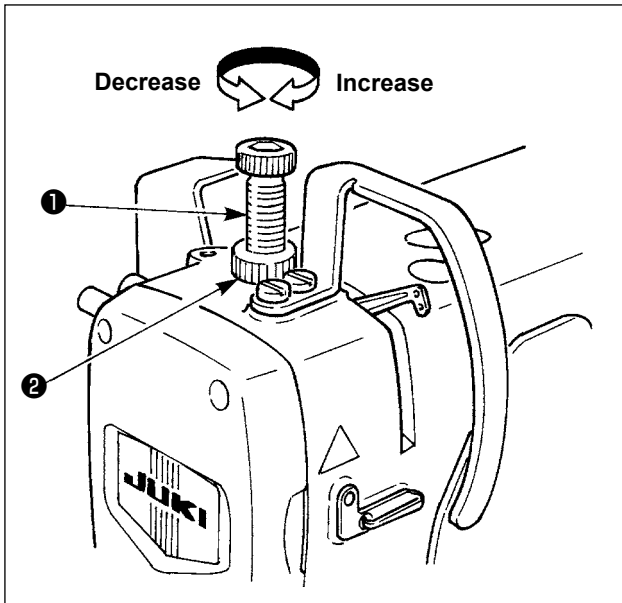

Loosen nut ② by turning counterclockwise, and turn presser spring regulator ① to adjust the pressure. Turn the regulator clockwise to increase the pressure and turn it counterclockwise to decrease the pressure.

After the adjustment, tighten nut ② .

5-4. Micro-lifter

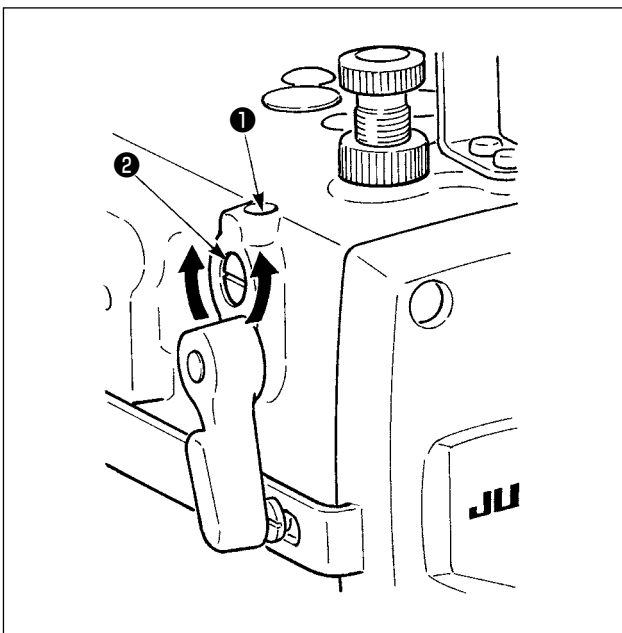

Loosen screw ① , turn micro-lifter pin ② , and the height of the presser foot can be adjusted to 0 to 0.5 mm.

5-5. Thread tension release changeover when using the knee lifter

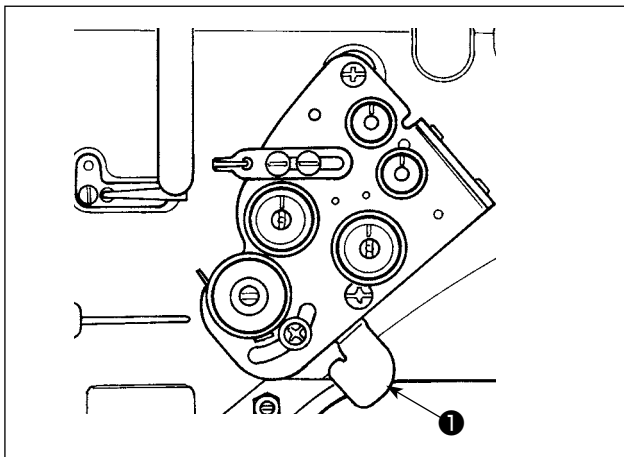

For the LH-3568A, 3568A-7, 3588A and 3588A-7, the thread tension release of the thread tension controller has been factory-interlocked with the knee lifter or AK device at the time of delivery.

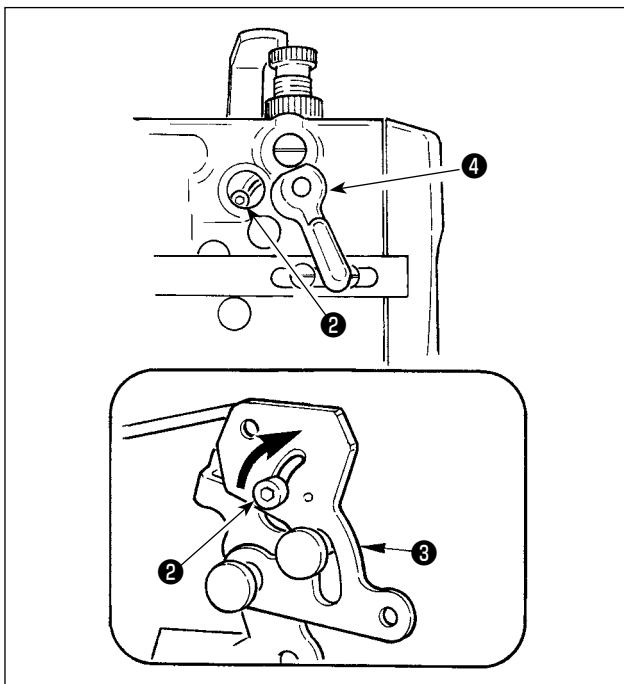

- In the case the thread tension release is not interlocked with the knee lifter or AK device

Remove the wiper solenoid in case of the machine with wiper. Remove the cap at the back, loosen screw 2, move screw 2 in the direction of arrow up to the end of slot of lifting link 3, and fix it.

The thread does not slacken unless thread tension release plate 1 or hand lifter lever 4 is actuated.



If you start sewing without releasing the thread tension, a load will be applied to the needle when the material is drawn out, resulting in needle bending or breakage.

5-6. One-touch manual reverse feed (One-touch reverse feed type)

[LH-3528A, 3528A-7 and 3578A-7]
0B type

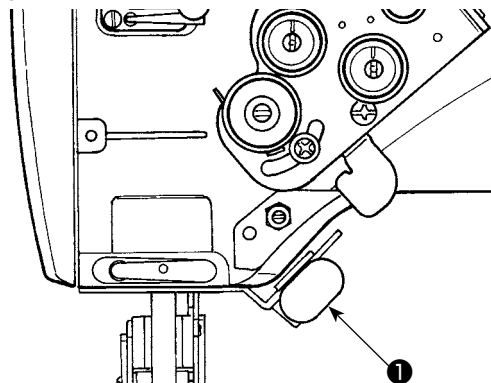

[LH-3568A-7 and 3588A-7]

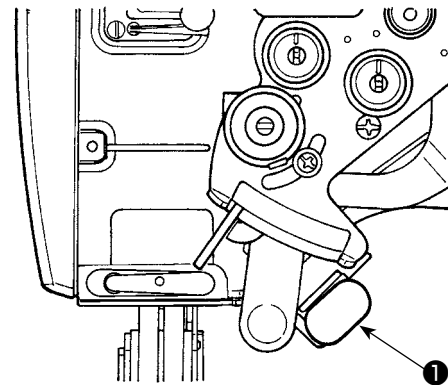

• How to use

- 1) Press switch 1, and the sewing machine will immediately run in the reverse direction to perform the reverse feed stitching.
- 2) Reverse stitching is made as long as you keep pressing the switch.
- 3) Release the switch, and the sewing machine will run in the normal direction.

6. MAINTENANCE

6-1. Procedure of changing over between bottom feed and needle feed and the adjustment (for LH-3528A only)



WARNING :

To protect against possible personal injury due to abrupt start of the machine, be sure to start the following work after turning the power off and ascertaining that the motor is at rest.

(1) Changing procedure to bottom feed and the adjustment

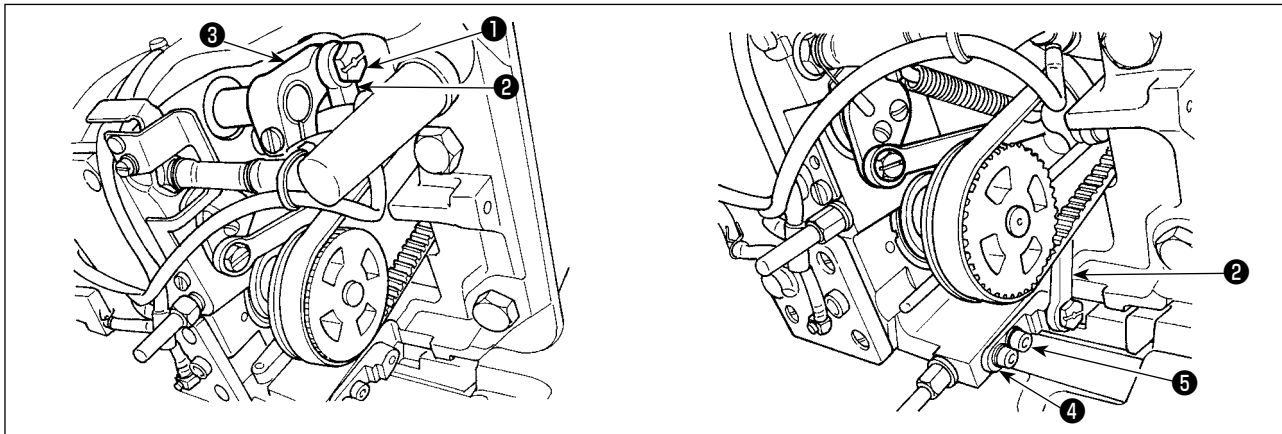

- 1) Set the stitch dial at the minimum value. Then, remove hinge screw ①. Move needle bar rocking rod ② from needle bar rocking rod arm ③ to needle rocking rod fixing base ④ and fix the rod with hinge screw ①.

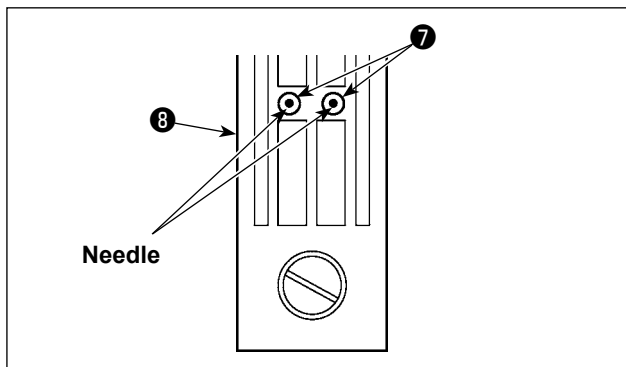

- 2) After replacing the feed dog and the throat plate with the components for bottom feed, adjust the position of needle rocking rod fixing base ④ so that the needle center aligns with needle holes ⑦ in throat plate ⑧, and fix setscrews ⑤. Then replace the presser foot with that for bottom feed as well.

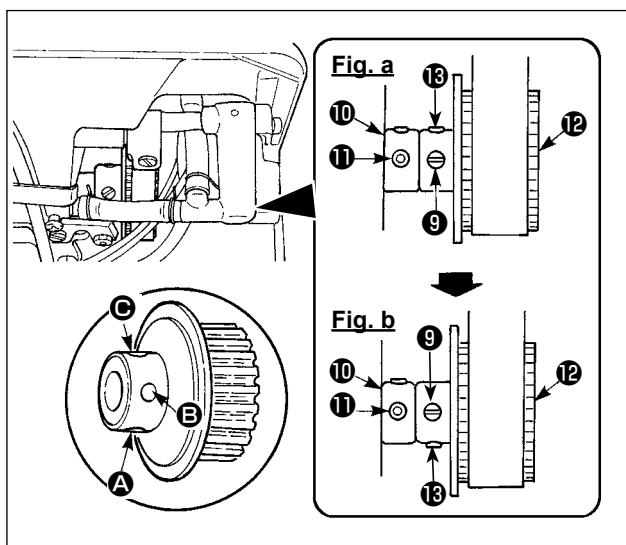

- 3) Loosen setscrews ⑨ and ⑬ (2 places) in sprocket ⑫. Loosen the setscrews in the order of ⑬ and ⑨. At this time, remove screw No. 1 ⑨ which is put in screw hole A in sprocket ⑫, and put it in screw hole C which is located on the opposite side at 180°. (Fig. a)
Turn the pulley by 180° without turning the hook driving shaft, align the flat section of the hook driving shaft with screw hole C in sprocket ⑫, and fix with setscrews ⑨. Screw No. 1 ⑪ in the hook driving shaft rear bearing ⑩ aligns with the flat section of the hook driving shaft. Make the state as the standard. (Fig. b)
Then fix screw No. 2 ⑬ which is put in screw hole B in sprocket ⑫ as well.

(2) Changing procedure to needle feed and the adjustment

The procedure is the reverse of "(1) Changing procedure to bottom feed and the adjustment".

Loosen hinge screw ① , move needle bar rocking rod ② from needle rocking rod fixing base ③ to needle bar rocking rod arm ④ , and fix it with hinge screw ① .

Replace the feed dog, the throat plate and, the presser with the components for needle feed.

Loosen setscrews ⑨ and ⑬ (2 places) in sprocket ⑫ . Loosen the setscrews in the order of ⑬ and ⑨ . At this time, remove the setscrew ⑨ which is put in screw hole ③, and put it in screw hole ① which is located on the opposite side at 180°. (Fig. b)

Turn the pulley by 180° without turning the hook driving shaft, align the flat section of the hook driving shaft with screw hole ① in sprocket ⑫ , and fix with setscrews ⑨ . It is the standard that screw No. 1 ⑪ in hook driving shaft rear bearing ⑩ aligns with the flat section of the hook driving shaft. (Fig. a)

Then fix screw No. 2 ⑬ which is put in screw hole ② in sprocket ⑫ as well.

6-2. Changing the feed timing

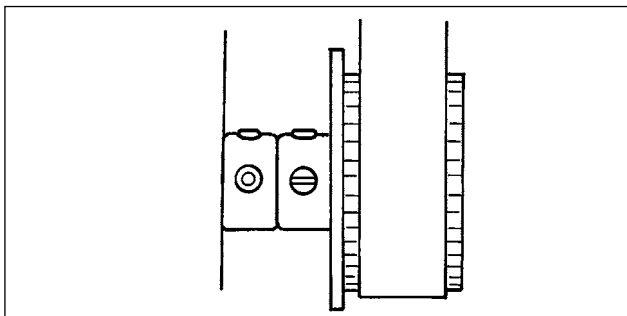

The feed timing has been factory-adjusted as illustrated in the sketch on the left.

The following describes how to change the feed timing to produce better-tensed seams from the state given in the sketch on the right.

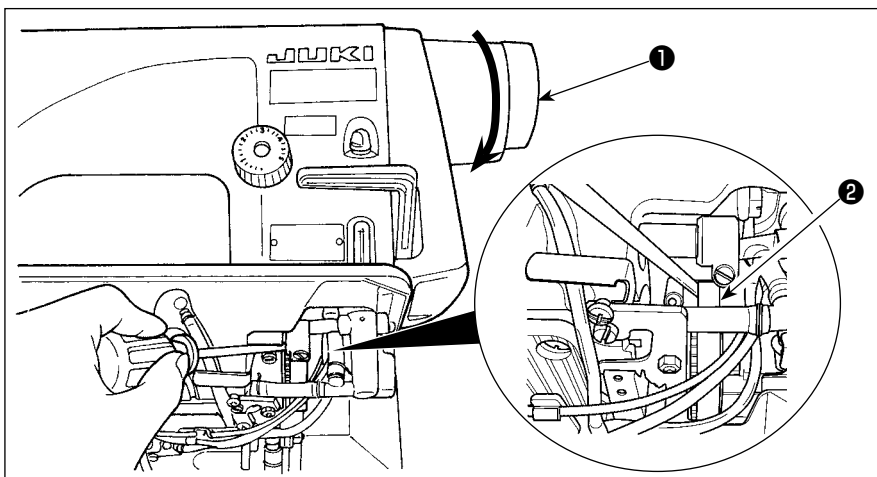

- 1) Turning pulley ①, remove timing belt ② from the pulley.

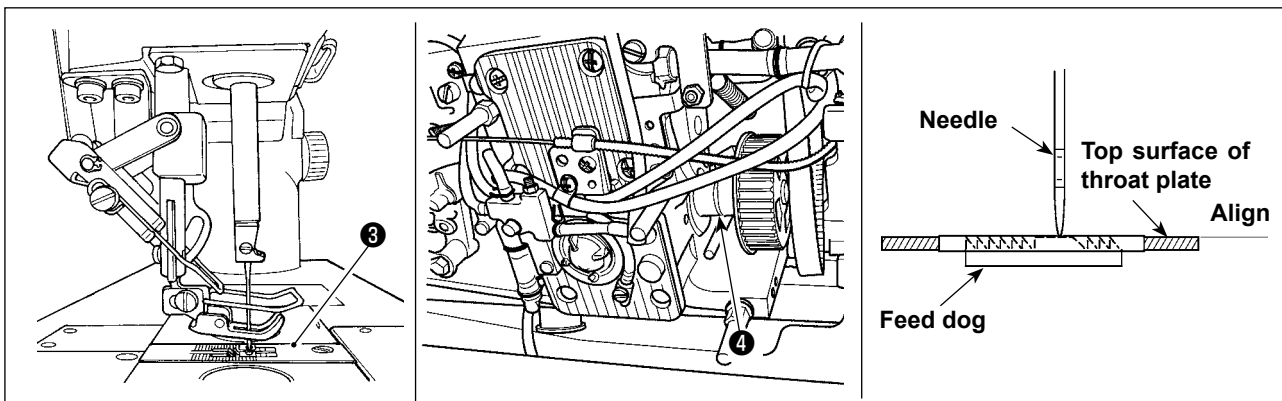

- 2) Turn pulley ① in the rotating direction of the sewing machine to lower the needle from its upper position until it aligns with throat plate ③.
- 3) Turn hook driving shaft ④ to raise the feed dog from its lower position until it is flush with the top surface of the throat plate.

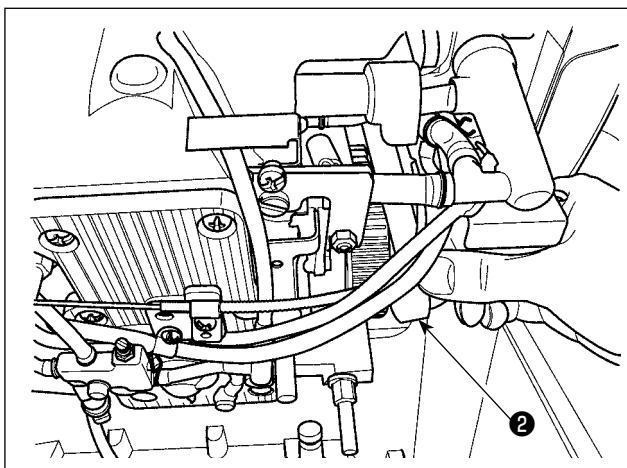

- 4) Carefully keeping the needle and the feed dog in the aforementioned state, put timing belt ② on the pulley.
- 5) Adjust the timing of the right and left hooks and adjust the timing of the thread trimming cam, referring to "4-17. Needle-to-hook relation" p.29 and "6-3. Adjusting the thread trimming cam" p.38.



The hook timing can change by removing/replacing the timing belt, resulting in a stitching failure. To prevent this, be sure to adjust the timing of the hook and thread trimming cam.

6-3. Adjusting the thread trimming cam

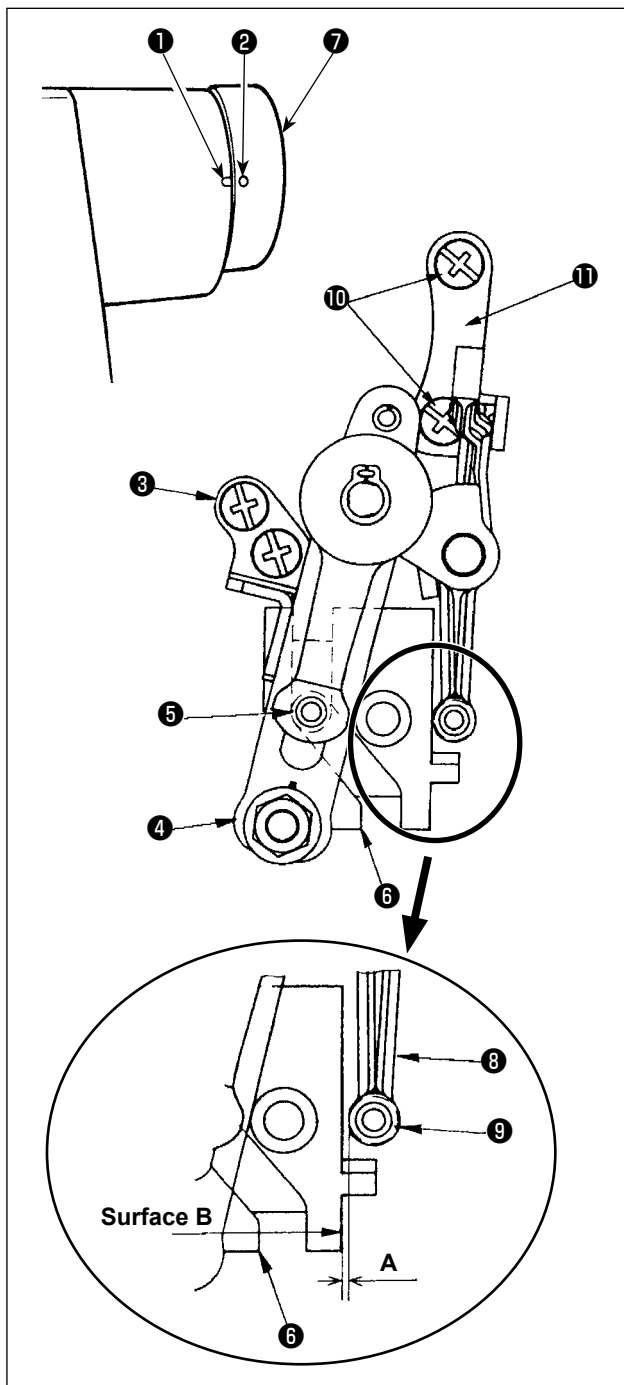

(1) Position of the thread trimming cam and the thread trimming timing

- 1) Align engraved marker dot ① on the arm with engraved marker dot ② (red) on the handwheel.
- 2) When thread trimmer driving arm stopper ③ comes in contact with knife driving arm ④, press cam roller ⑤ into the groove in thread trimming cam ⑥.
- 3) Keeping the aforementioned state, turn thread trimming cam ⑥ until the location as indicated in the sketch on the left is reached. When the thread trimming cam is brought to the location as indicated in the sketch (the intermediate point of the section where the shape of groove in thread trimming cam ⑥ changes from linear shape to diagonal shape), tighten two clamping screws of thread trimming cam ⑥.

[Checking the timing of the thread trimming cam]

- 1) Press cam roller ⑤ into the groove in the cam until it securely fits in there.
- 2) Turn handwheel ⑦ in the opposite direction of the rotating direction of the sewing machine until its smooth move is hindered. At this time, check to be sure that engraved marker dot ① on the arm is aligned with engraved marker dot ② (red) on the handwheel.

(2) Clearance between the thread trimming cam and thread tension release arm

- 1) Depress thread tension release arm ⑧.
- 2) At this time, adjust so that clearance A of 0.5 mm is provided between surface B of the right end face of thread trimming cam ⑥ and roller section ⑨ of thread tension release arm ⑧.
- 3) To adjust, loosen two setscrews ⑩, adjust the position of thread tension release driving arm stopper ⑪ so that it is spaced 0.5 mm from surface B, and tighten two setscrews ⑩.

* In the case the clearance is larger than 0.5 mm:
The space pin mechanism does not rise enough, resulting in a thread trimming failure.

* In the case the clearance is smaller than 0.5 mm:

Roller section ⑨ comes in contact with thread trimming cam ⑥ to disable the thread trimmer operation.

6-4. Adjusting the hook needle guard



WARNING :

To protect against possible personal injury due to abrupt start of the machine, be sure to start the following work after turning the power off and ascertaining that the motor is at rest.

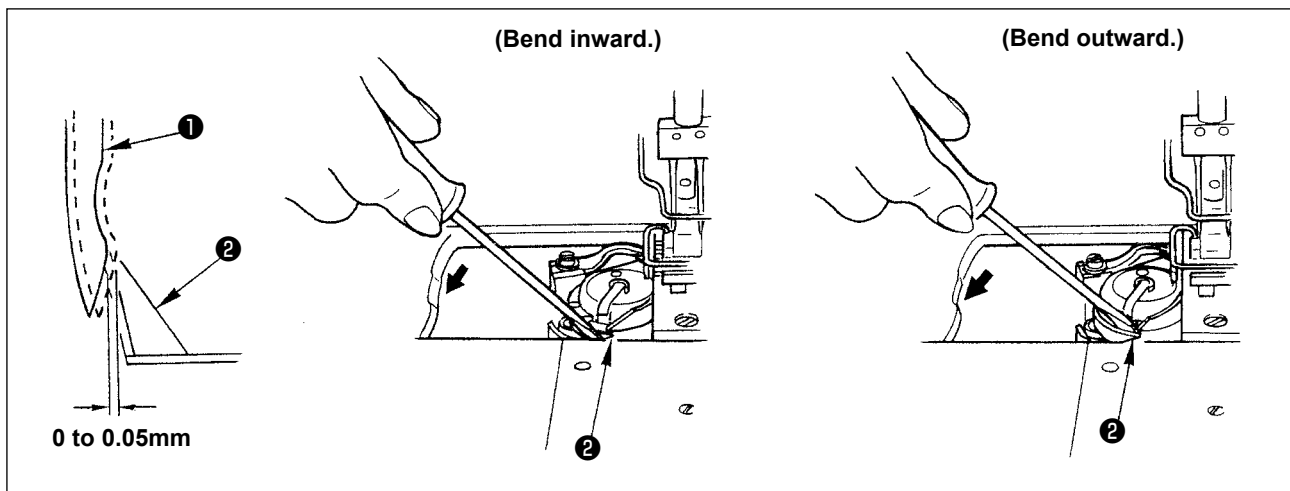

When replacing the hook, confirm the position of the needle guard.

The standard position of the hook needle guard is obtained when hook needle guard ② comes in contact with the side face of needle ① and the engagement length between the needle and the hook needle guard is 0 to 0.05 mm. If not, adjust by bending the hook needle guard.

- 1) When bending the hook needle guard inward, perform by entering a screwdriver to the outside of the hook needle guard.
- 2) When bending the hook needle guard outward, perform by entering a screwdriver to the inside of the hook needle guard.

At this time, confirm that the clearance between the needle and the blade point of hook is 0.01 to 0.05 mm.

(Refer to "4-17. Needle-to-hook relation" p.29.)

6-5. Adjusting the inner hook guide



WARNING :

To protect against possible personal injury due to abrupt start of the machine, be sure to start the following work after turning the power off and ascertaining that the motor is at rest.

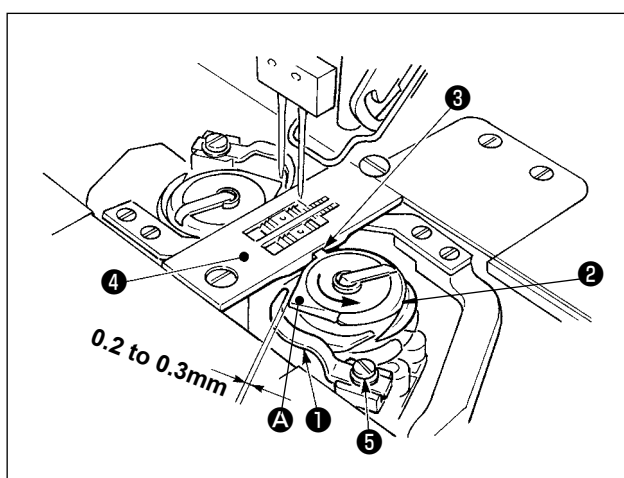

- 1) Turn the handwheel in the normal direction to bring inner hook guide ① to the extreme rear position.
- 2) Turn bobbin case ② in the direction of the arrow, and make inner hook stopper ③ come in contact with the groove of throat plate ④ .
- 3) Loosen inner hook guide setscrew ⑤ , set the clearance between the inner hook guide and protrusion ① of the bobbin case to 0.2 to 0.3 mm, and securely tighten inner hook guide setscrew ⑤ .

6-6. Adjusting the height and the inclination of the feed dog



WARNING :

To protect against possible personal injury due to abrupt start of the machine, be sure to start the following work after turning the power off and ascertaining that the motor is at rest.

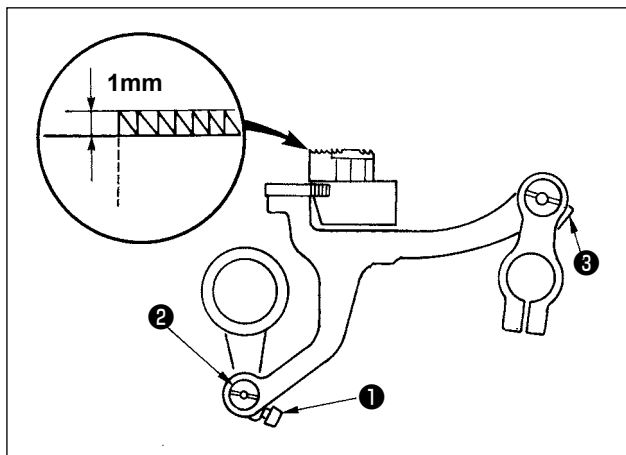

(1) Adjusting the height

- 1) Loosen feed driving link setscrew **1**. Turn feed driving link shaft **2** to adjust the height of the feed dog. Standard height is 1 mm from the throat plate in the highest position.

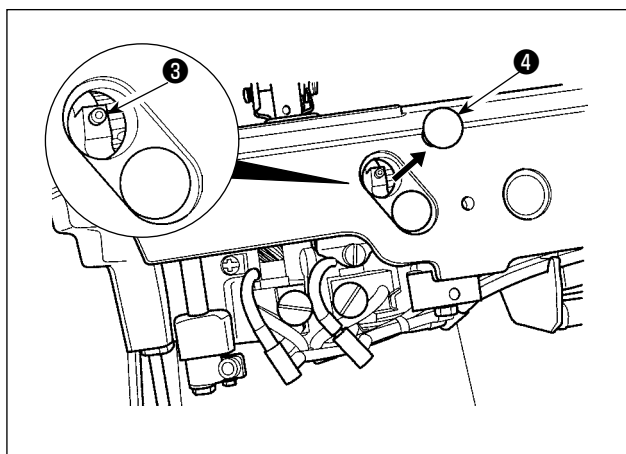

(2) Inclination

- 1) Remove cap **4** on the side of machine bed, loosen feed bar shaft setscrew **3**, and turn knurled section **5** to adjust the inclination. Standard inclination is the position where engraved marker dot **A** of feed bar arm aligns with engraved marker dot **B** of feed bar shaft. (Engraved marker dot **C** is not used.)

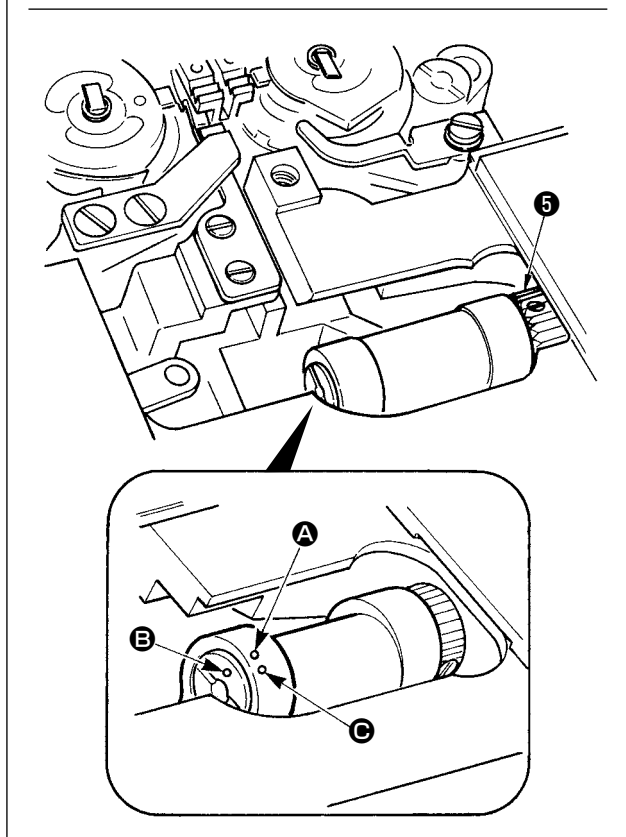

6-7. Replacing the gauge



WARNING :

To protect against possible personal injury due to abrupt start of the machine, be sure to start the following work after turning the power off and ascertaining that the motor is at rest.

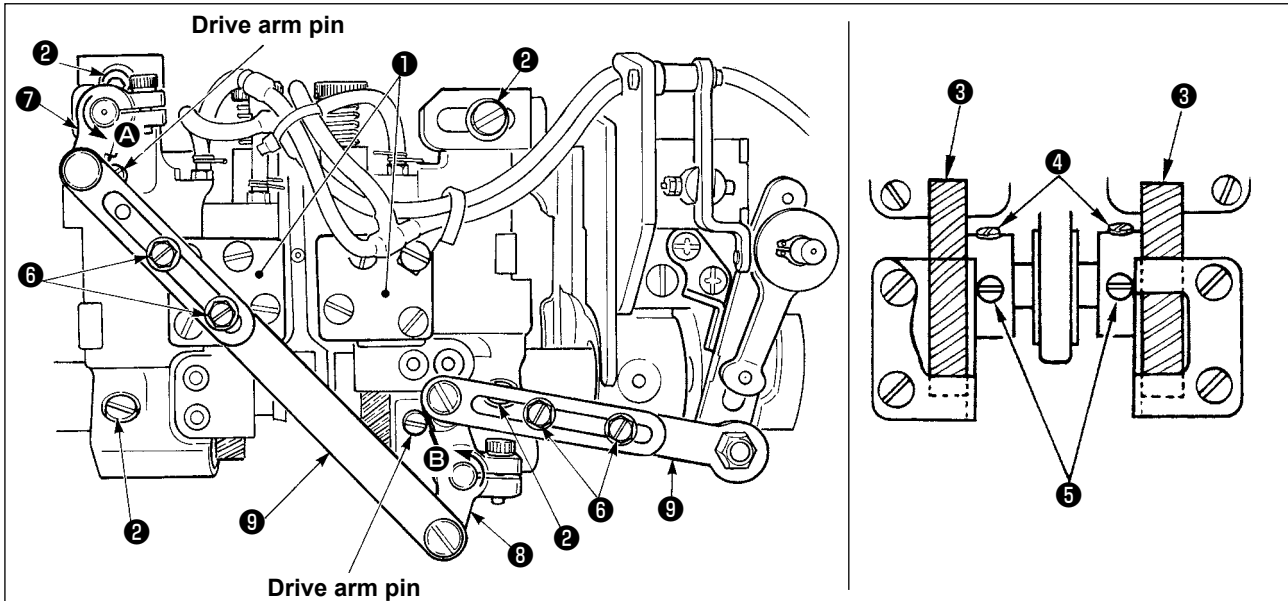

• Move of the hook shaft saddle when replacing the gauge

- 1) Loosen screws No. 2 ④ of hook driving shaft gears ③ .
 - 2) Align the needle with the blade point of hook.
 - 3) Slightly loosen screws No. 1 ⑤ of hook driving shaft gears ③ so that the screws does not come off the flat section of the hook driving shaft.
- Loosen four setscrews ⑥ of connecting link (asm.) ⑨ . (Sewing machine with thread trimmer)
- 4) Loosen two setscrews ② of hook shaft saddle ① , and move the hook shaft saddle.
(At this time, the hook driving shaft gears move as well.)
 - 5) Set the clearance between the needle and the blade point of hook to 0.01 to 0.05 mm.
 - 6) Tighten two setscrews ② of the hook shaft saddle.
 - 7) Tighten from screws No. 1 ⑤ at the position where the clearance between hook driving shaft gears ③ and hook shaft saddles ① is 0.5 mm. Then tighten screws No. 2 ④ .
- Make driving arms ⑦ and ⑧ come in contact with the driving arm pin in the directions of A and B respectively and tighten four setscrews ⑥ in connecting link (asm.) ⑨ . (Sewing machine with thread trimmer)

6-8. Adjusting the thread presser spring



WARNING :

To protect against possible personal injury due to abrupt start of the machine, be sure to start the following work after turning the power off and ascertaining that the motor is at rest.

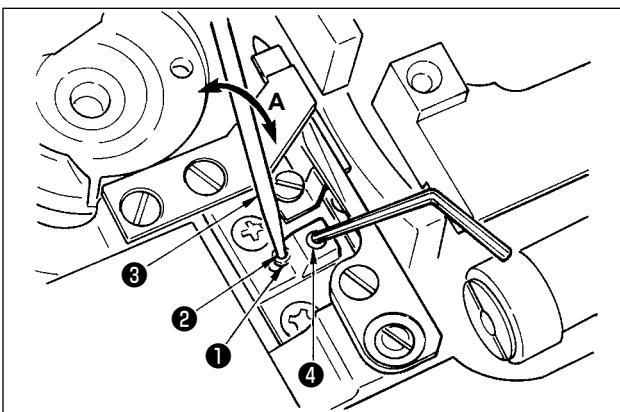

Insert a rod (thin rod, wrench, etc.) into adjusting hole ② in thread presser spring base ① , and loosen setscrew ④ with a hexagonal wrench key of 1.5 mm. Adjust the thread presser spring by moving rod ③ in the direction of arrow mark A, and fix it with setscrew ④ .



Clamp trouble occurs even when the thread presser spring pressure is excessive or insufficient. So, be careful.

6-9. Adjusting the position of the moving knife



WARNING :

To protect against possible personal injury due to abrupt start of the machine, be sure to start the following work after turning the power off and ascertaining that the motor is at rest.

(1) Types of parts

A/S type

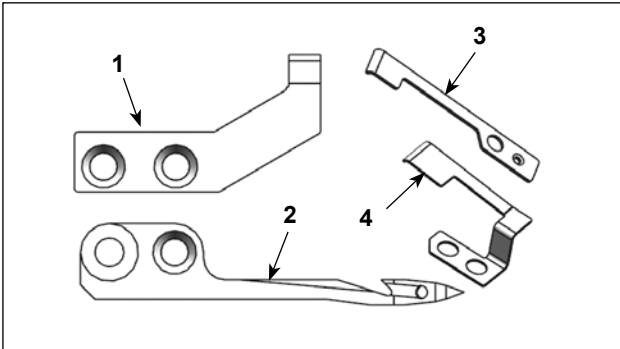

| A/S type | | |
|----------|----------|---------------|
| 1 | 40012404 | Counter knife |
| 2 | 40109415 | Moving knife |
| 3 | 40076708 | Clamp spring |
| 4 | 40076709 | Clamp |

G type

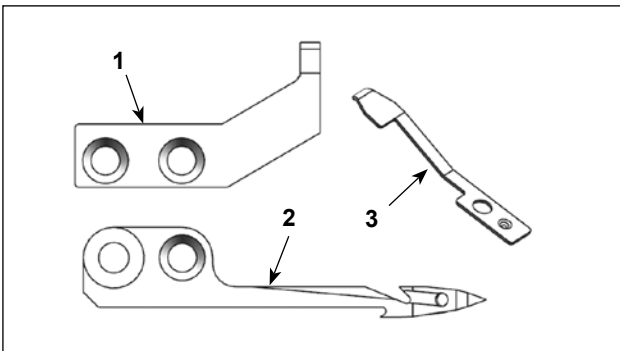

| G type | | |
|--------|----------|---------------|
| 1 | 40098763 | Counter knife |
| 2 | 40098762 | Moving knife |
| 3 | 40098764 | Clamp |

(2) Work procedure

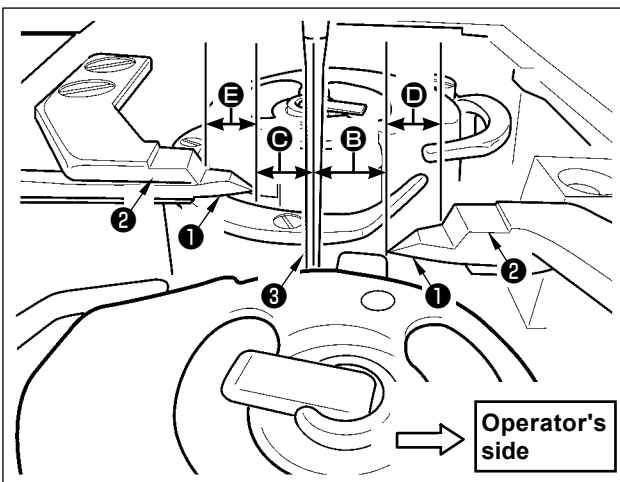

- Loosen clamp screw ④ in the rear of machine bed and adjust so that distances ③ and ④ between the top end of moving knife ① and the center of needle ③ at the time of waiting become the dimensions as shown in the list below when the feed pitch is minimum and needle ③ is in its lower dead point.

| | | Left knife | | Right knife | |
|-----|-----------|------------|---------------------|-------------|---------------------|
| | | ③ | (④ Reference value) | ④ | (③ Reference value) |
| A/S | LH3528A-7 | 6.2 | (3.5) | 7.5 | (2.7) |
| | LH3568A-7 | | | | |
| G | LH3528A-7 | 6.9 | (3.2) | 7.8 | (2.4) |
| | LH3568A-7 | | | | |
| | LH3578A-7 | 7.3 | (3.8) | 8.9 | (3.1) |
| | LH3588A-7 | | | | |

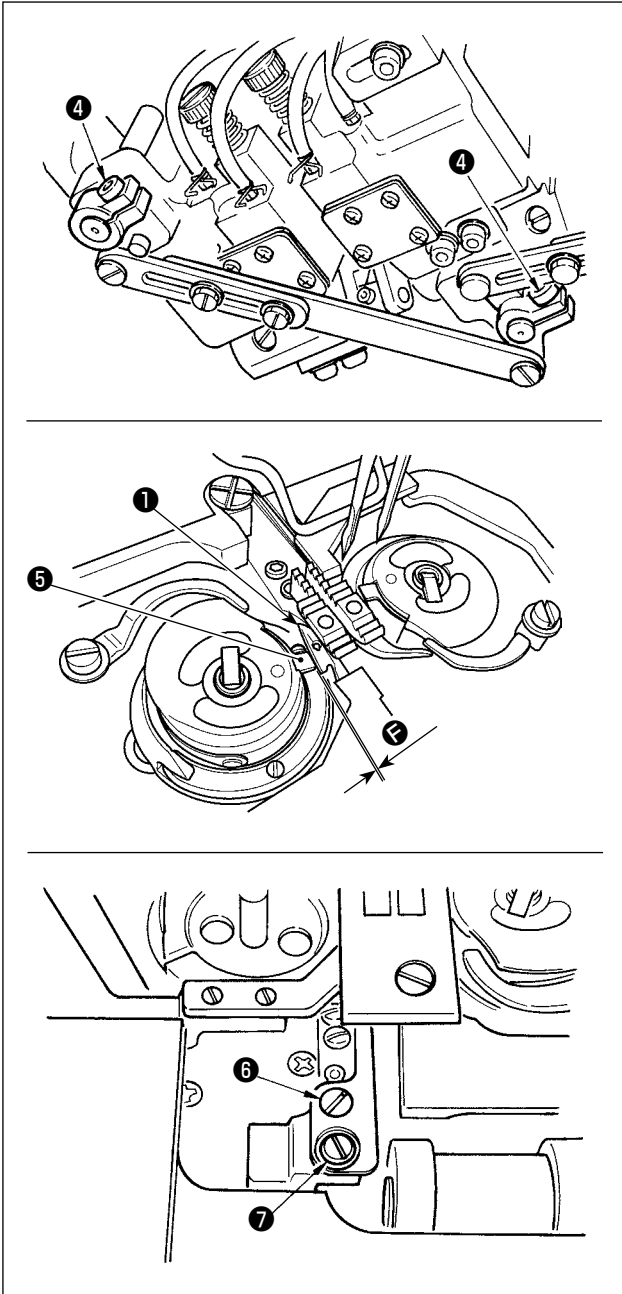

- 2) Refer to the list shown below for clearance **F** between moving knife **1** and protrusion **5** of the inner hook during operation. Loosen moving knife setscrews **6** and **7**, and adjust the clearance.

| | | F | |
|-----|-----------|------------|-------------|
| | | Left knife | Right knife |
| A/S | LH3528A-7 | 0.2 to 0.4 | 0.2 to 0.4 |
| | LH3568A-7 | | |
| G | LH3528A-7 | 0.1 to 0.3 | 0.1 to 0.3 |
| | LH3568A-7 | | |
| | LH3578A-7 | 0.3 to 0.5 | 0.3 to 0.5 |
| | LH3588A-7 | 0.1 to 0.2 | 0.1 to 0.2 |

6-10. Adjusting the counter knife position, knife pressure and clamp



WARNING :

To protect against possible personal injury due to abrupt start of the machine, be sure to start the following work after turning the power off and ascertaining that the motor is at rest.

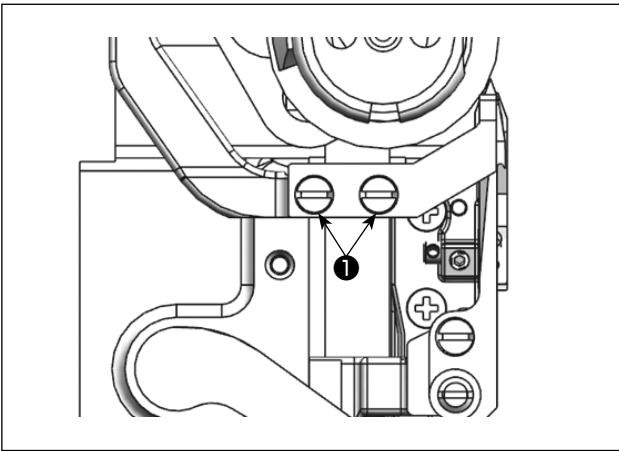

- 1) Adjusting the engagement of the counter knife
Loosen setscrews **1** of the counter knife. Finely adjust the counter knife following the caution described below.
After the adjustment, tighten setscrews **1**.

[Caution to be taken when adjusting the counter knife engagement]



If the counter knife is not completely engaged as shown in **B**, damage of the counter knife and/or thread trimming failure can occur.

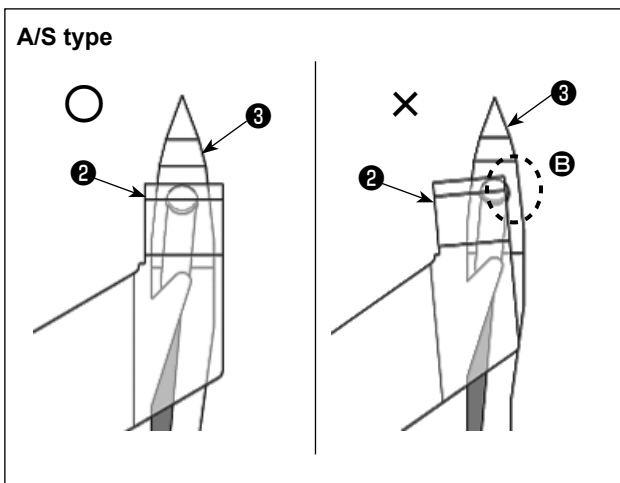

• A/S type

Counter knife **2** should engage with moving knife (eye) **3** without fail.

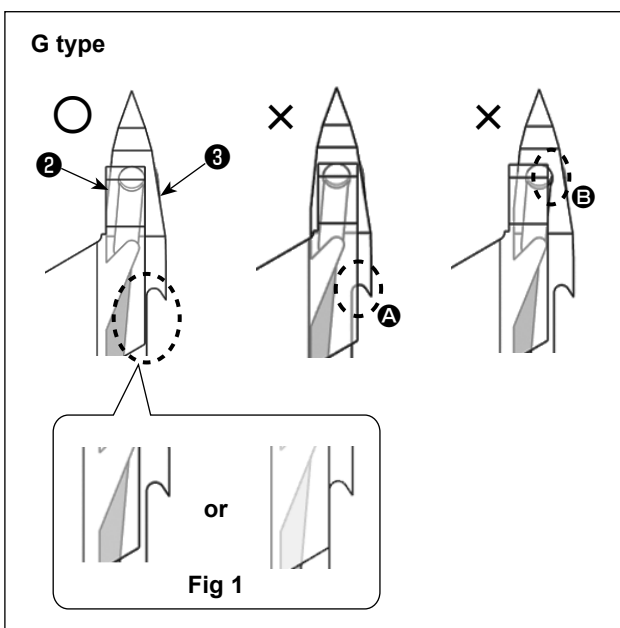

• G type

1. Counter knife **2** should engage with moving knife (eye) **3** without fail.
2. Adjust so that the right side of counter knife **2** is aligned with left end face of the needle thread spreading hook section of moving knife **3** or a small clearance is provided between them (Fig. 1).
The counter knife should not engage with **A** section of the needle thread spreading hook.

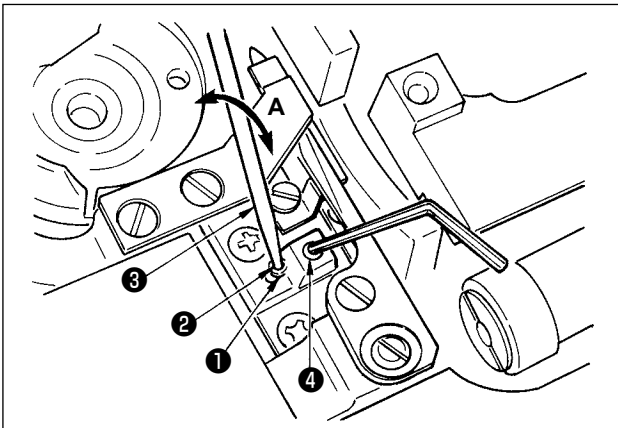
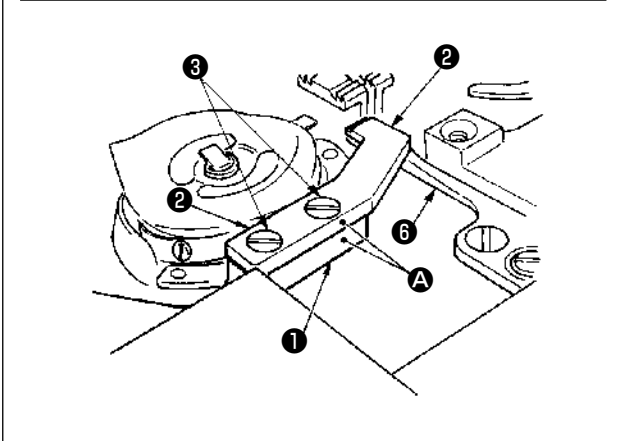
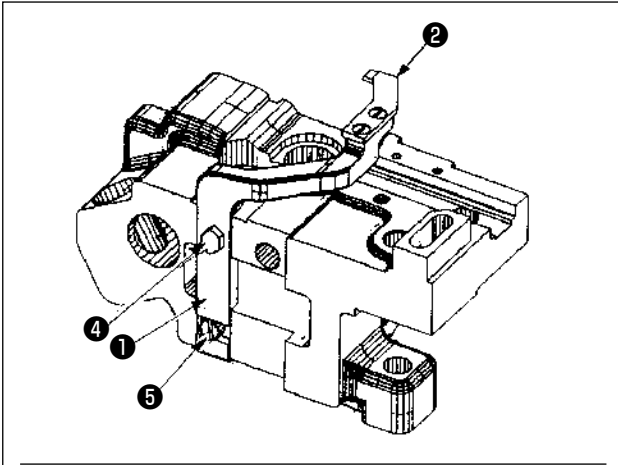

2) Adjusting the knife pressure

1. Loosen setscrew ④ of counter knife base ① .
Adjust the height of the counter knife with eccentric pin ⑤ to adjust the knife pressure of counter knife ② adequately.
2. The standard adjustment value of the counter knife position is obtained by adjusting eccentric pin ⑤ to the position that is reached by turning eccentric pin ⑤ in such a direction as to push moving knife ⑥ (downward) by approximately 10° after counter knife ② comes in contact with moving knife ⑥ .

If the counter knife pressure is too high :

- The thread will be trimmed easily, but the counter knife will wear off quickly.
- Operating load of the moving knife will increase resulting in, sometimes, thread trimming failure due to the moving knife malfunction.



If the counter knife pressure is too low :

- The thread may not be trimmed.
- Single yarn of the thread will remain after thread trimming. The needle thread will be caught in the thread trimmer to cause the needle thread to be hitched when the material is taken out from the sewing machine.

3) Adjusting the clamp pressure

1. Insert rod (thin rod, wrench key or the like) ③ into adjustment hole ② in clamp base ① . In this state, loosen setscrew ④ with a 1.5-mm hexagonal wrench.
2. Adjust the clamp by moving rod ③ in the direction of the arrow A, and secure with setscrew ④ .



Be aware that clamp defects can occur if the clamp pressure is excessively high or low.

6-11. Position of the wiper



WARNING :

To protect against possible personal injury due to abrupt start of the machine, be sure to start the following work after turning the power off and ascertaining that the motor is at rest.

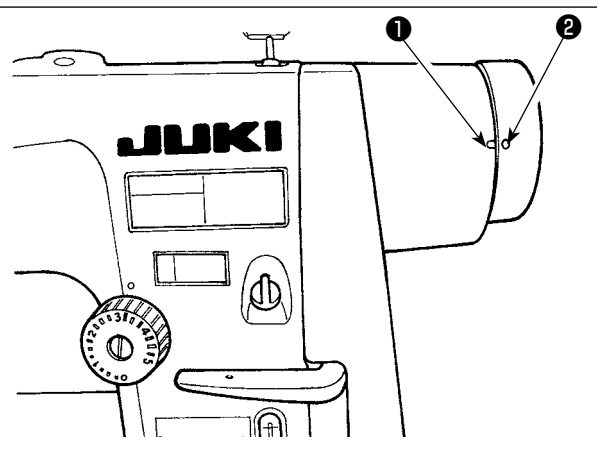
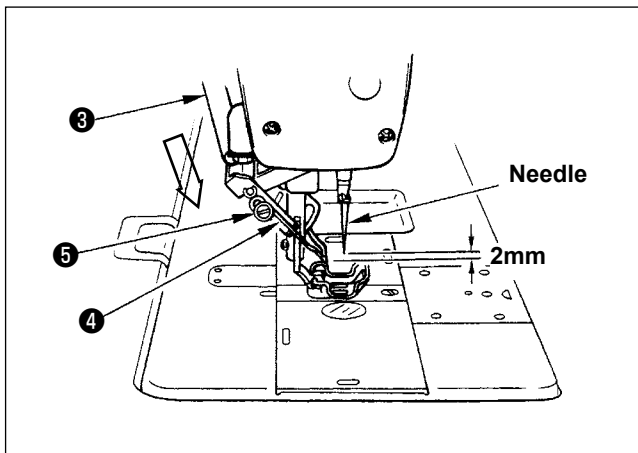

- 1) Adjust engraved marker dot ① on the machine arm to white marker dot ② on the handwheel.
- 2) Move rod ③ in the direction of the arrow, and adjust with two clamping screws ⑤ so that the clearance between the top end of needle and wiper ④ is approximately 2 mm.

6-12. Caution when installing the attachments

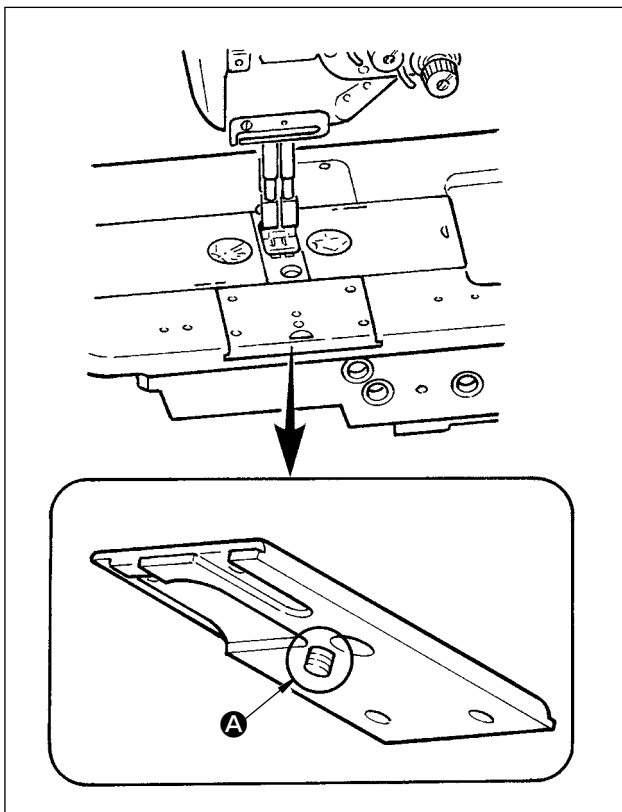

Be careful that screw **A** does not protrude in the rear of the bed slide when fixing the attachment to the bed slide with the screw.



When it protrudes as shown in the figure, the screw interferes with other components and break-down will be caused.

6-13. Replacing the bobbin thread slack preventer spring (For LH-3568A, 3568A-7, 3588A and 3588A-7)

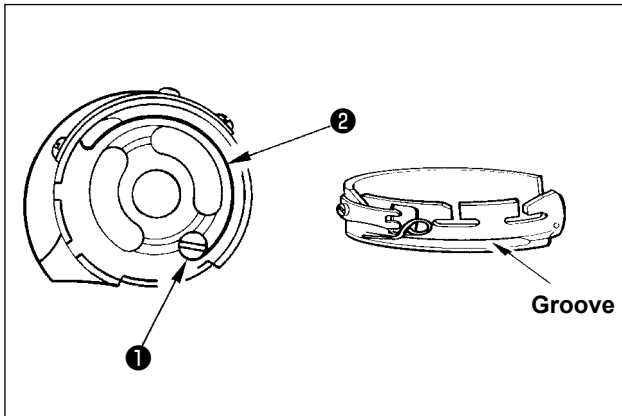

- 1) Loosen screw ① and remove bobbin thread slack preventer spring ② from the groove on the bobbin case.
- 2) Fit bobbin thread slack preventer spring ② which replaces the removed spring in the bobbin case through the groove.
- 3) Fix bobbin thread slack preventer spring ② in the bobbin case by tighten screw ①. At this time, carefully check the operating range and tension or the spring.

6-14. Stop of the needle bars and angle of corners for corners stitching (For LH-3568A, 3568A-7, 3588A and 3588A-7)

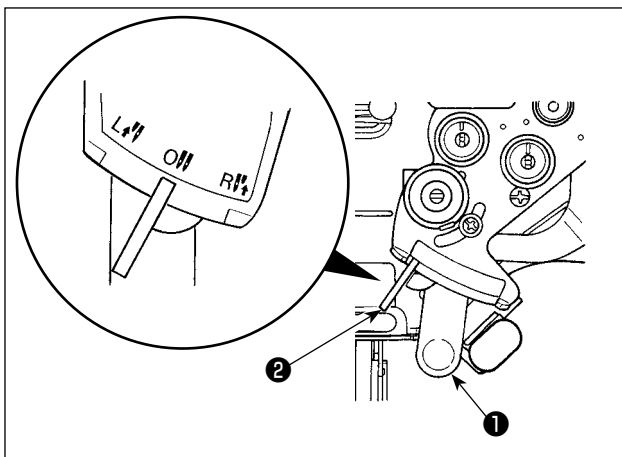

- Stop of the needle bar
When change lever ① is moved to position L, the left-hand needle bar stops, and when it is moved to position R, the right-hand needle bar stops.

- When returning to 2-needle operation
Press change fixing lever ②. Change lever ① returns to the position "0", and the machine returns to 2-needle sewing.

- Relation between the angle of corners and stitch length

To perform corner stitching with accuracy, the stitch length can be determined referring to the table of the number of stitches by gauges.

However, check whether the stitch length determined really matches the corner by actually sewing it.

(Example)

To sew a corner of 90° of angle using a 3/16" gauge with the stitch length specified to 1.6mm, the number of stitches can be obtained in the following way. Observe the "90°" columns on the table of the number of stitches by stitch length gauges to search for the column in which "1.6" is indicated. Then, you can find "3" on the top of the "1.6" lines. This means the number of stitches is 3.

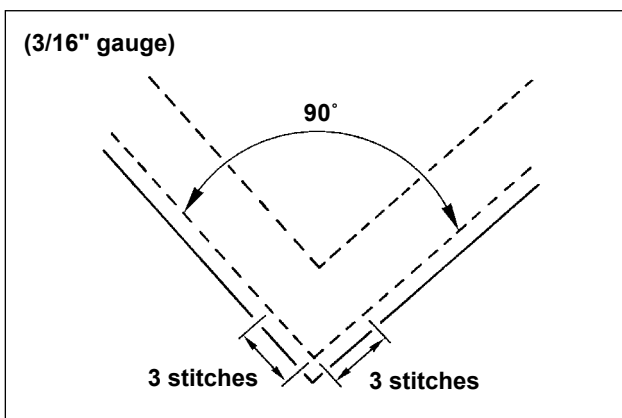

- If sewing a corner of which angle is 40° or less, the thread take-up amount of the bobbin thread slack preventer spring will be insufficient. In this case, the thread will remain on the wrong side of the material.
- When performing the operation of changeover of separately driven needle bar, perform the work after stopping the sewing machine once. When the operation of changeover is performed at 1,000 sti/min or more, break-down will be caused.)
- When the sewing machine is used as the substitute for 1-needle sewing machine in the state of separately driven needle bar, break-down of the sewing machine will be caused. When performing sewing with 1-needle sewing machine, remove one of two needles and use the sewing machine in the state that two needle bars operate.



7. STITCH-TO-ANGLE TABLE BY GAUGE (PITCH AND mm CONVERSION TABLE)

1/8"(3.17mm)

| Turning angle \ Number of stitches | 1 | 2 | 3 | 4 | 5 | 6 | 7 | 8 | 9 |
|------------------------------------|-----|-----|-----|-----|-----|-----|---|---|---|
| 40 | | 4.4 | 2.9 | 2.2 | 1.7 | 1.5 | | | |
| 50 | | 3.4 | 2.3 | 1.7 | | | | | |
| 60 | | 2.7 | 1.8 | | | | | | |
| 70 | 4.5 | 2.3 | 1.5 | | | | | | |
| 80 | 3.8 | 1.9 | | | | | | | |
| 90 | 3.2 | 1.6 | | | | | | | |
| 100 | 2.6 | | | | | | | | |

5/32"(3.96mm)

| Turning angle \ Number of stitches | 1 | 2 | 3 | 4 | 5 | 6 | 7 | 8 | 9 |
|------------------------------------|-----|-----|-----|-----|-----|-----|-----|---|---|
| 40 | | | 3.6 | 2.7 | 2.2 | 1.8 | 1.6 | | |
| 50 | | 4.2 | 2.8 | 2.1 | 1.7 | | | | |
| 60 | | 3.4 | 2.3 | 1.7 | | | | | |
| 70 | | 2.8 | 1.9 | | | | | | |
| 80 | 4.7 | 2.4 | 1.6 | | | | | | |
| 90 | 4.0 | 2.0 | | | | | | | |
| 100 | 3.3 | 1.7 | | | | | | | |

3/16"(4.76mm)

| Turning angle \ Number of stitches | 1 | 2 | 3 | 4 | 5 | 6 | 7 | 8 | 9 |
|------------------------------------|-----|-----|-----|-----|-----|-----|-----|-----|-----|
| 40 | | | | 3.3 | 2.6 | 2.2 | 1.9 | 1.6 | 1.5 |
| 50 | | | 3.4 | 2.6 | 2.0 | 1.7 | 1.5 | | |
| 60 | | | 2.7 | 2.1 | 1.6 | 1.4 | | | |
| 70 | | 3.4 | 2.3 | 1.7 | 1.4 | | | | |
| 80 | | 2.8 | 1.9 | 1.4 | | | | | |
| 90 | 4.8 | 2.4 | 1.6 | | | | | | |
| 100 | 4.0 | 2.0 | | | | | | | |

7/32"(5.56mm)

| Turning angle \ Number of stitches | 1 | 2 | 3 | 4 | 5 | 6 | 7 | 8 | 9 |
|------------------------------------|-----|-----|-----|-----|-----|-----|-----|-----|-----|
| 40 | | | 5.1 | 3.8 | 3.1 | 2.5 | 2.2 | 1.9 | 1.7 |
| 50 | | | 4.0 | 3.0 | 2.4 | 2.0 | 1.7 | 1.5 | |
| 60 | | 4.8 | 3.2 | 2.4 | 1.9 | 1.6 | | | |
| 70 | | 4.6 | 2.6 | 2.0 | 1.6 | | | | |
| 80 | | 3.3 | 2.2 | 1.7 | | | | | |
| 90 | 5.6 | 2.8 | 1.9 | 1.4 | | | | | |
| 100 | 4.7 | 2.3 | 1.6 | | | | | | |

1/4"(6.35mm)

| Turning angle \ Number of stitches | 1 | 2 | 3 | 4 | 5 | 6 | 7 | 8 | 9 |
|------------------------------------|---|-----|-----|-----|-----|-----|-----|-----|-----|
| 40 | | | | 4.4 | 3.5 | 2.9 | 2.5 | 2.2 | 2.0 |
| 50 | | | 4.6 | 3.4 | 2.8 | 2.3 | 2.0 | 1.7 | 1.6 |
| 60 | | | 3.7 | 2.8 | 2.2 | 1.9 | 1.6 | | |
| 70 | | 4.6 | 3.1 | 2.3 | 1.9 | 1.6 | | | |
| 80 | | 3.8 | 2.6 | 1.9 | 1.6 | | | | |
| 90 | | 3.2 | 2.2 | 1.6 | | | | | |
| 100 | | 2.7 | 1.8 | | | | | | |

9/32"(7.14mm)

| Turning angle \ Number of stitches | 1 | 2 | 3 | 4 | 5 | 6 | 7 | 8 | 9 |
|------------------------------------|---|-----|-----|-----|-----|-----|-----|-----|-----|
| 40 | | | | 4.9 | 3.9 | 3.3 | 2.8 | 2.5 | 2.2 |
| 50 | | | 5.1 | 3.8 | 3.1 | 2.6 | 2.2 | 1.9 | 1.7 |
| 60 | | | 4.1 | 3.1 | 2.5 | 2.1 | 1.8 | 1.5 | |
| 70 | | 5.1 | 3.4 | 2.5 | 2.0 | 1.7 | 1.5 | | |
| 80 | | 4.3 | 2.8 | 2.1 | 1.7 | 1.4 | | | |
| 90 | | 3.6 | 2.4 | 1.8 | 1.4 | | | | |
| 100 | | 3.0 | 2.0 | 1.5 | | | | | |

5/16"(7.93mm)

| Turning angle \ Number of stitches | 1 | 2 | 3 | 4 | 5 | 6 | 7 | 8 | 9 |
|------------------------------------|---|-----|-----|-----|-----|-----|-----|-----|-----|
| 40 | | | | | 4.4 | 3.7 | 3.2 | 2.8 | 2.5 |
| 50 | | | | 4.3 | 3.4 | 2.9 | 2.5 | 2.2 | 1.9 |
| 60 | | | 4.6 | 3.5 | 2.8 | 2.3 | 2.0 | 1.8 | 1.6 |
| 70 | | | 3.8 | 2.9 | 2.3 | 1.9 | 1.7 | 1.5 | |
| 80 | | 4.8 | 3.2 | 2.4 | 1.9 | 1.6 | | | |
| 90 | | 4.0 | 2.7 | 2.0 | 1.6 | | | | |
| 100 | | 3.4 | 2.3 | 1.7 | | | | | |

3/8"(9.52mm)

| Turning angle \ Number of stitches | 1 | 2 | 3 | 4 | 5 | 6 | 7 | 8 | 9 |
|------------------------------------|---|-----|-----|-----|-----|-----|-----|-----|-----|
| 40 | | | | | | 4.4 | 3.7 | 3.3 | 2.9 |
| 50 | | | | | 4.1 | 3.4 | 2.9 | 2.6 | 2.3 |
| 60 | | | | 4.1 | 3.3 | 2.7 | 2.4 | 2.1 | 1.8 |
| 70 | | | 4.5 | 3.4 | 2.7 | 2.3 | 1.9 | 1.7 | |
| 80 | | | 3.8 | 2.8 | 2.3 | 1.9 | 1.6 | | |
| 90 | | 4.8 | 3.2 | 2.4 | 1.9 | 1.6 | | | |
| 100 | | 4.0 | 2.7 | 2.0 | 1.6 | | | | |

1/2"(12.7mm)

| Turning angle \ Number of stitches | 1 | 2 | 3 | 4 | 5 | 6 | 7 | 8 | 9 |
|------------------------------------|---|-----|-----|-----|-----|-----|-----|-----|-----|
| 40 | | | | | | 5.8 | 5.0 | 4.4 | 3.9 |
| 50 | | | | | 5.5 | 4.5 | 3.9 | 3.4 | 3.0 |
| 60 | | | | 5.5 | 4.4 | 3.7 | 3.1 | 2.8 | 2.4 |
| 70 | | | | 4.5 | 3.6 | 3.0 | 2.6 | 2.3 | 2.0 |
| 80 | | | 5.1 | 3.8 | 3.1 | 2.5 | 2.2 | 2.0 | 1.7 |
| 90 | | | 4.2 | 3.2 | 2.5 | 2.1 | 1.8 | 1.6 | 1.4 |
| 100 | | 5.3 | 3.6 | 2.7 | 2.1 | 1.8 | 1.5 | 1.3 | |

8. TROUBLES AND CORRECTIVE MEASURES

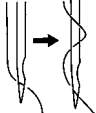
| TROUBLES | CAUSES | CORRECTIVE MEASURES |
|---|--|--|
| <p>1. Thread breakage (Thread is untwisted or scraped.)</p> <p style="text-align: center; margin-top: 20px;">(Needle thread 2 to 3 cm is left on the wrong side of the fabric.)</p> <p style="text-align: center; margin-top: 20px;">(Bobbin thread comes out of the bobbin.)</p> | <ol style="list-style-type: none"> ① There is a sharp edge or burr on the thread path, needle point, hook blade point or bobbin case resting groove on the throat plate. ② Needle thread tension is too high. ③ Bobbin case opening lever provides an excessive clearance at the bobbin case. ④ Hook blade point hits the needle. ⑤ Hook is not lubricated properly. ⑥ Needle thread tension is too low. ⑦ Thread take-up spring is too tight and its stroke is too small. ⑧ Needle-to-hook timing is wrong. ⑨ Thread untwines. ⑩ Uniform thread loops cannot be formed when making chain-off thread. ⑪ Bobbin is wound with excessive amount of thread. (In particular, filament thread) | <ul style="list-style-type: none"> ○ Remove sharp edge or burr using a fine sandpaper. Polish the surface of the bobbin case resting groove on the throat plate using a buffing wheel. ○ Adjust the needle thread tension. ○ Reduce the clearance. (Refer to "6-5. Adjusting the inner hook guide" p.39.) ○ Refer to "4-17. Needle-to-hook relation" p.29. ○ Increase the amount of oil supplied to the hook according to "4-4. Adjusting the amount of oil in the hook" p.9. ○ Adjust the needle thread tension. ○ Reduce the tension of the spring and increase the stroke. ○ Refer to "4-17. Needle-to-hook relation" p.29. ○ Wind the thread on the needle. <ul style="list-style-type: none">  ○ Use the thread guide equipped with felt pad. ○ Use the optional needle clamp wire. ○ Wind the bobbin with thread by 80 % of its capacity. |
| <p>2. Stitch skipping</p> | <ol style="list-style-type: none"> ① Clearance between the needle and the hook blade point is too great. ② Needle-to-hook relation is wrong. ③ Pressing force of the presser foot is not enough. ④ Needle bar height is wrong. ⑤ Needles are a little too thin. ⑥ Synthetic thread or thin thread is used. ⑦ Stitch skipping occurs at the beginning of sewing. ⑧ Stitch skips when sewing multilayered parts of the material. ⑨ Stitch skipping occurs when the material thickness changes, i.e., from a two-ply part to a multi-layered part and vice versa. | <ul style="list-style-type: none"> ○ Refer to "4-17. Needle-to-hook relation" p.29. ○ Refer to "4-17. Needle-to-hook relation" p.29. ○ Tighten the presser spring regulator. ○ Refer to "4-17. Needle-to-hook relation" p.29. ○ Replace the needle by thicker ones. ○ Wind the thread on the needle. ○ Use the optional needle clamp wire. ○ Run the sewing machine under the soft start mode by 2 to 3 stitches from the sewing start. ○ Use the needle thread guide and precisely adjust the hook timing. ○ Move the presser foot toward the operator. At this time, be careful not to allow the presser foot to come in contact with the needle. |

| TROUBLES | CAUSES | CORRECTIVE MEASURES |
|---|--|---|
| 3. Loose stitch | <ul style="list-style-type: none"> ① Bobbin thread does not pass through the forked end of the tension spring on the bobbin case. ② Thread path has rough surface. ③ Bobbin does not spin smoothly. ④ Bobbin case opening lever provides too much clearance at the bobbin. ⑤ Bobbin thread tension is too low. ⑥ Bobbin is wound too tightly. ⑦ The presser foot does not securely press the multi-layered section of the material. ⑧ Needle eyelet is too small for thickness of thread, preventing smooth take-up motion of the thread take-up lever. ⑨ With respect to tensing of thick thread, neither needle thread tension nor bobbin thread tension can be increased, resulting in production of isolated idling loops. ⑩ Isolated idling loops are produced during the reverse feed stitching. | <ul style="list-style-type: none"> ○ Thread the bobbin case correctly. ○ Remove rough surface using a fine sandpaper or polish the surface using a buffing wheel. ○ Replace the bobbin or the hook. ○ Refer to "6-5. Adjusting the inner hook guide" p.39. ○ Adjust the bobbin thread tension. ○ Adjust the tension components on the bobbin winder. ○ Change presser foot with the hinging presser (B1524512FBE). (The presser foot with large front and rear elevation angles is preferable.) ○ Retard the hook timing by 2 to 3 degrees. ○ Use the needle thread take-up eyelet. ○ Use the needle thread presser. ○ Use the bobbin thread tension spring t0.3 (22612808). ○ Retard the hook timing. |
| 4. Thread trimming failure | <ul style="list-style-type: none"> ① The position of the moving knife is not correct. ② Bobbin thread cannot be trimmed by dropping the thread trimmer. | <ul style="list-style-type: none"> ○ Refer to "6-9. Adjusting the position of the moving knife" p.42. ○ Use the feed dog with thicker teeth (2 mm). ○ Retard the thread trimming cam timing by 5°. |
| 5. Amount of idling is excessively large. | <ul style="list-style-type: none"> ① The counter knife pressure is inadequate. ② Backlash between the bobbin and the bobbin case is excessively large. ③ The idling prevention spring does not work adequately. ④ The idling prevention sheet is not placed. ⑤ Thread trimming speed is too high. | <ul style="list-style-type: none"> ○ Increase the knife pressure. Refer to "6-8. Adjusting the thread presser spring" p.41. ○ Re-select the bobbin and the bobbin case. ○ Increase the spring pressure. ○ Place the sheet in position. ○ Decrease the thread trimming speed. |
| 6. Clamp failure | <ul style="list-style-type: none"> ① The clamp pressure has adjusted to an excessively high or low value. ② The clamp pressure works excessively, resulting permanent set in fatigue of the clamp plate clamp spring. ③ The bobbin thread slips off due to the bobbin thread slack prevention spring of the cap hook. ④ Due to difference in thread count number between the needle thread and bobbin thread, they excessively tangle with each other at the time of thread trimming. ⑤ The feed dog height is too low. | <ul style="list-style-type: none"> ○ Increase or decrease the clamp pressure. Refer to "6-8. Adjusting the thread presser spring" p.41. ○ Change the clamp plate clamp spring with a new one. ○ Remove the bobbin thread slack prevention spring. ○ Use the optional clamp style cap hook. ○ Increase the tension applied by the tension controller No. 1. ○ Retard the timing of the thread trimming cam. ○ Increase the feed dog height. |

9. MOTOR PULLEY AND BELT

■ Motor pulley and belt for the machine without thread trimmer are as described below.

- 1) Use a clutch motor with an output 400 W (2P).
- 2) Use M type V belt.
- 3) The relation between the motor pulley, belt length and number of revolutions of sewing machine is as shown in the list below.

| LH-3528A, 3568A, 3578A and 3588A | | | | | |
|----------------------------------|-------------|------------------------|------|-----------|-------------|
| Motor pulley | | Sewing speed (sti/min) | | Belt | |
| Outer diameter(mm) | Part No. | 50Hz | 60Hz | Length | Part No. |
| 75 | MTKP0070000 | 3000 | - | 43 inches | MTJVM00430A |
| 70 | MTKP0065000 | 2790 | - | | |
| 65 | MTKP0060000 | 2580 | 3000 | 42 inches | MTJVM00420A |
| 60 | MTKP0055000 | 2370 | 2740 | | |

- * The effective motor pulley diameter is obtained by subtracting 5 mm from the outer diameter.
- * The motor should rotate counterclockwise when viewed from the pulley side. Be careful not to rotate it in the counter direction.