

***ENGLISH***

**F-1F  
INSTRUCTION MANUAL  
(Mechanical)**

---

## **INSTRUCTIONS**

---

Thank you very much for purchasing F1F Series machine.

This instruction manual describes daily routine maintenance and safety precautions to keep the machine in the best possible conditions.

Please study this manual very carefully before operating the machine.

---

# CONTENTS

<b>Copyright</b> .....	1
<b>Directive</b> .....	1
<b>1.Introduction</b> .....	2
<b>2.Indicatons of dangers,warnings &amp; cautions</b> .....	2~3
<b>3.Safety precautions</b> .....	3~4
<b>4.Notes for each procedure</b> .....	4~6
<b>5.Location of warning labels and safety devices</b> .....	7
<b>6.Protectors for safety</b> .....	8
Schematic diagram of the machine table .....	9
Assembling the machine rest board .....	10
Lubrication .....	11
Silicone oil for H.R. device .....	12
Threading .....	13~14
Adjusting presser foot pressure .....	15
Adjusting the differential feed ratio .....	15
Adjusting stitch length .....	15
Adjusting the thread tension .....	16
Cleaning the machine .....	16
Replacing the needle .....	17
Oil replacement .....	17
To drain the oil .....	17
Checking and cleaning the oil filter .....	18
Adjustment dimensions	
Comparison table of equivalent sizes	
Standard needle .....	19
F1F Subclass specifications .....	20
GUEGE PARTS LIST .....	21

Be sure to study very carefully **for safety.**

---

## Copyright

---

### ● Disclaimer

The contents described in this instruction manual are intended for giving information and subject to change without notice. We assume no responsibility for these informaton, and any errors and/or incorrect descriptions that may appear in this instruction manual.

● This model has a policy that we always modify the performance and/or specifications of this product introducing the state-of-the-art technology. Accordingly we reserve the right to change the specifications and/or design without notice.

● This instruction manual is valid for all the models and subclasses listed in the chapter "Specifications."

---

## Directives

---

This machine is constructed in accordance with the European regulations contained in the conformity and manufacturer's declarations. In addition to this instruction manual, strictly observe all the generally accepted, statutory regulations, legal requirements and all the environmental protection regulations. Also rigidly adhere to the regionally valid regulations of the social insurance society for occupational accidents or other supervisory organizations.

---

---

## **1.Introduction**

---

- This is the instruction manual that describes how to use this product safely.
- Read this instruction manual and learn very carefully how to operate, adjust and service this sewing machine before beginning any of the procedures.
- You should realize first that there is always the risk of contacting moving parts, such as needles because you have to work at point-blank range to them when you are operating industrial sewing machines. For safety it is essential that we supply safe products and you use them correctly and safely. There may be some safety measures that you yourself must take. Therefore, you should read and understand very carefully this instruction manual together with that of the driving equipment and take necessary safety measures in order to use this machine efficiently and effectively.

---

---

## **2.Indications of dangers,warnings and cautions**

---

To prevent accidents and ensure safety,warning indications which show the degree of danger are used on our products and in this manual.



Study the contents of these indications carefully and follow all warnings and instructions.

Indication labels should be found easily.

Attach new ladels when they are stained or removed.









Contact our sales office when new labels are needed.

### **Symbols,signs and/or signal words which attract users'attention**

 <b>DANGER</b>	Indicates an immediate hazard to life or limb.
 <b>WARNING</b>	Indicates a potential hazard to life or limb.
 <b>CAUTION</b>	Indicates a possible mistake that could result in injury or damage.

Be sure to study very carefully **for safety.**

### Symbols, and messages

	Be sure to follow the instructions when you operate the machine and/or labor saving device.
	If you use the machine and/or labor saving device incorrectly, you may get an electrical shock.
	If you use the machine and/or labor saving device incorrectly, your hands and/or fingers may be injured.
	Indicates a danger of burn injury due to high temperature.
	Never do this.
	Unplug the machine or shut off the power when checking, adjusting and/or repairing the machine and/or labor saving device, or when lightning may strike.
	Be sure to ground the machine and labor saving device securely.
	Denotes the normal rotating direction of the machine pulley.

### 3. Safety precautions

#### ① Applications, purpose

Our industrial sewing machines have been developed in order to increase quality and/or production in the sewing industry. Accordingly never use our products for other than intended use described above.

#### ② Circumstances

The environment in which our industrial sewing machines are used may seriously affect their lives, functions, performance and/or safety.

 For safety, do not use the machine under the circumstances below.

1. Do not use the machine near objects which make noise such as a high-frequency welder, etc.
2. Do not use or store the machine in the air which has vapor from chemicals, or do not expose the device to chemicals.
3. Do not leave the machine outside, in high temperatures or the direct sun.
4. Do not use the machine in the places of high ambient temperature and humidity that seriously affects sewing machines.

5. Do not use the machine on the condition that the voltage fluctuation range is more than  $\pm 10\%$  of the rated voltage.

6. Do not use the machine in the place where the supply voltage specified for the control motor cannot be properly obtained.

#### ③ Safety measures

 (1) Safety precautions when you perform maintenance on the machine.

- Always turn off the power, unplug the machine and then make sure that the machine does not run by pressing the treadle before performing any maintenance, such as checking, repairing, cleaning, etc. However, if you need to perform these procedures with the power on, to prevent accidents due to the unexpected start of the machine and users' misoperation, establish your own procedures for safety and follow them.

 ● Always turn off the power and unplug the machine before performing the procedures shown below.

- Lubrication
- Threading
- Cleaning
- Replacing the needle
- Checking/replacing the oil element
- Replacing the oil

Always turn off the power before performing the procedures shown below.

- Adjusting the stitch length
- Adjusting the differential feed ratio

Only well-trained people should perform routine daily maintenance and/or repair the machine.



Do not modify the machine yourself.

Consult your local Pegasus's sales office or representative for modification.



(2) Before operating the machine

Check the machine head and unit for any damage and/or faulty function at the start of each day.  
If there should be something wrong with the machine, immediately perform repairs and/or other necessary procedures.

Check by hand to see if the needle holder is secured.  
Be careful of the needle point.

Before starting the machine, make sure that the presser foot is positioned correctly (turn the machine pulley slowly by hand to see if the needle point is centered in the needle drop hole on the presser foot).

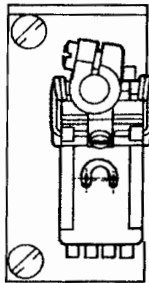

Check to see if the presser foot is secured (raise the presser foot by the foot lifter and press it by hand front to back and left to right).

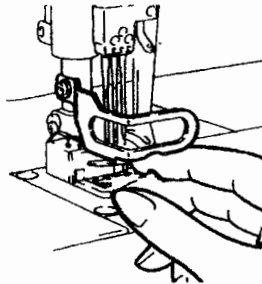

(3) Training

To prevent accidents, operators and service/maintenance personnel should have proper knowledge and skills for safe operation.  
To ensure so, managers must design and conduct training for these people.

## 4. Notes for each procedure

### CAUTION

#### ② Unpacking

- The machine is packaged in a cardboard box before shipping. Unpack your machine in orderly sequence while checking them right-side up by referring to the indications, such as logo, etc. printed on the boxes.
- Never hold the area near the needle and/or thread guide related parts when taking out the machine from the cushion. Otherwise it may cause injury and/or damage to the machine.
- Take out the machine very carefully while checking the position of the center of the gravity.
- Keep the cardboard box and packing carefully in case secondary transport is needed in the future.

#### Disposal of the packaging

The packaging material of the machine consists of wood, paper, cardboard and VCE fiber. The proper disposal of the packaging is the responsibility of the customer.

#### Disposal of machine waste

- The proper disposal of machine waste is the responsibility of the customer.
  - The materials used on the machines are steel, aluminum, brass and various plastics.
  - The machine waste is to be disposed of in accordance with the locally valid environmental protection regulations. A specialist should be commissioned if necessary.
- ※ The parts contaminated with lubricants should be disposed off separately according to the locally valid environmental protection regulations.

#### Transport within the customer's premises

The manufacturer assumes no liability for transport within the customer's premises. Care should be taken to transport the machine in an upright position avoiding it from dropping or falling down to the ground when it is moved.

////////// Be sure to study very carefully **for safety.** //////////

## WARNING

### ② Transportation

1. The machine should be carried by at least more than two people when it is mounted on the table and/or a hand truck.

Be sure to use a hand truck for other transportation.

2. To carry the machine, hold the machine pulley tightly with your right hand and the machine arm with your left upper arm.

If the machine and/or your hands are stained with oil, the machine may be easy to slip out of your hands and fall to the floor.

Therefore, wipe off the oil carefully.

3. Care should be taken to avoid excessive shock and shake when the machine is mounted on the table and/or transferred using a hand truck. Otherwise the machine may fall down.

4. Wipe off the oil from the machine before packaging it again for secondary transport. Otherwise the machine may easily slip out of your hands or the bottom of the box may come off while in transit.

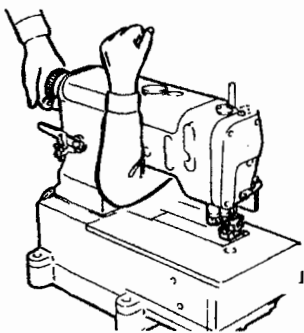

## CAUTION

### ③ Installation, preparation

#### Machine table

1. Use the machine table (table board, metal legs) that completely carries the machine and is fully resistant to warping while the machine is running.

2. Arrange the working environment for easy operation by considering where to place the machine and the brightness around the working area. If the illumination is insufficient, control or change lighting as required.

3. Attach a non-slip pad to the treadle (foot switch).

Otherwise the operator may slip off the treadle while running the machine, causing trouble.

4. Adjust the height of the table according to a working posture of the operator.

## WARNING

### Cables

1. When connecting the cables between the machine and the motor, be sure to turn off the power and connect each cable connectors securely.

2. Do not strain the cables in use.

3.  Do not bend the cables excessively.

4. When connecting the cables that are close to the moving parts, such as pulley or V belt, keep a distance of 25mm at least between them.

5. Protect each cable using a cover or adjusting its position if necessary.

6.  Never use staples to fasten the cables. Otherwise it causes a short circuit and/or a fire.

## CAUTION

### Motor

1. Install the machine motor correctly by referring to the instruction manual supplied by the manufacturer.

2. Select the machine motor equipped with the pulley cover so that any part of your body etc. is not caught in the belt.

## CAUTION

### Ground

1. Connect each of the ground wires in the sewing machine system to the ground terminal. Do not connect to another devices'.

2.  Connect the ground wires securely to the indicated ground points on the machine head.

## WARNING

### ④ Handling machine oil

1. Never start the machine with no oil in the reservoir. Use the following oil.

Pegasus designated oil: HIGH SPEED SEWING MACHINE OIL or Equivalents: ESSOTEX SM22 manufactured by Exxon Mobil.

2. If machine oil gets in your eyes, it may cause eye irritation.

To prevent the machine oil from getting in your eyes, wear a pair of protective glasses.

※ Should machine oil gets in your eyes, wash them with fresh water for 15 minutes and then go to see a doctor.



3. Avoid skin contact. Immediately wash contacted areas completely with water and soap.
4.  Never swallow machine oil.
5. Keep machine oil out of the reach of children. If swallowed, do not induce vomiting. Immediately go to see a doctor.
6. Dispose of the waste oil and/or containers properly as demanded by law. If you have further questions on its disposal, consult the store or shop at which you purchased it.
7. After opening the oil container, be sure to seal it to prevent dust and water from getting into the oil and keep it in the dark to avoid direct sunlight.

## WARNING



### Before starting the machine

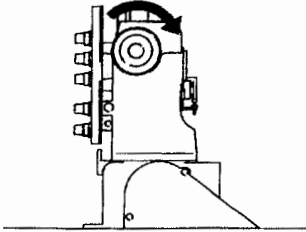

#### Machine table

1. Before turning the power on, visually check the cables and connectors for defective conditions, such as damage, disconnection and/or loosening.
  2. Never bring your hands close to the needle and/or pulley when turning on the power.
  3. When the machine is used for the first time, turn on the power and then check the rotating direction of the machine pulley. The machine pulley should turn clockwise as seen from the machine pulley.
- 
4. Well trained operators should use the machine after studying these precautions and the instruction manual carefully.
  5. Regarding symbols that indicate a danger or a warning, read and study "2. Warning indications" carefully and give training on safety to the operators as required.
  6. Run the machine at the speed less than 3/4 of its maximum for the first one month.

## WARNING



### Precautions while you are running the machine

1.  Do not run the machine with the safety devices removed, such as eye guard, finger guard, pulley cover, etc.
2.  Never bring your hands under the needle while running the machine.

3. A clutch motor keeps on running for a while after the power is turned off. Therefore, be careful even after the power is turned off as the machine could start running by pressing the machine treadle.
4.  To prevent accidents, never bring any part of your fingers, hair and clothes near the machine pulley, V belt, motor pulley, thread take-up and needle bar. Also never leave scissors, tweezers, tools, etc. around these areas.
5.  If you use the machine with the FT device, do not bring any part of your hands and fingers too close to the FT during sewing. Otherwise it may cause accidents and physical injury.
6. Always turn off the power while the machine is not used or before leaving the machine table.
7. In the event of a power failure, be sure to turn off the power.
8. While operating the machine, wear clothes that cannot be caught in the machine.
9.  Do not put any tools or other unnecessary objects on the machine table while running the machine.

## CAUTION

### Maintenance, Check, Repair

1. Well trained people should perform maintenance, check and repair of the machine after studying these precautions and the instruction manual carefully.
2.  If it is necessary to lay the machine backward for maintenance, check and repair, always turn off the power, unplug the machine and press the treadle to make sure that the machine does not operate before beginning any of the procedures.
3.  Before installing/removing the V belt, always turn off the power, unplug the machine and press the treadle to make sure the machine does not operate.
4. Carry out daily maintenance work and periodical inspections properly by following these precautions and the instruction manual.
5. Employ Pegasus' genuine parts when repairing the machine and/or replacing the parts. We are not responsible for accidents caused by any improper repair/adjustment and substituting other parts for those manufactured by Pegasus.
6. Do not attempt to modify the machine at your own discretion. We are not responsible for accidents caused by the modification.
7. Be sure to replace the safety devices and/or safety covers that are temporarily removed for maintenance and/or adjustment.
8. After performing maintenance, check and repair, make sure that turning on the power does not pose any danger to you.

////////// Be sure to study very carefully **for safety.** //////////

### 5. Location of warning labels and safety devices

	<b>注意</b>	运动的部分容易受伤。 安装安全保护装置方可进行 缝制作业。切断电源以后才 可进行穿线、交换梭芯或针、 清扫或调整作业。
	<b>CAUTION</b>	
		Moving parts may cause injury. Operate with safety devices. Turn off main switch before threading, changing bobbin and needle, cleaning etc.



小心伤手  
CAUTION

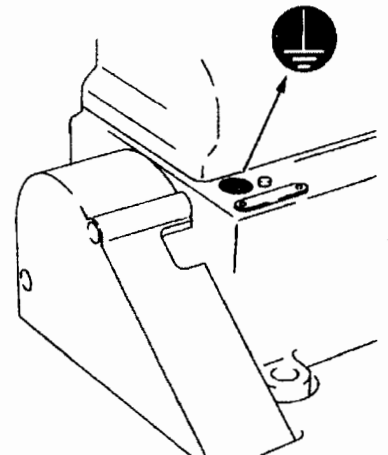
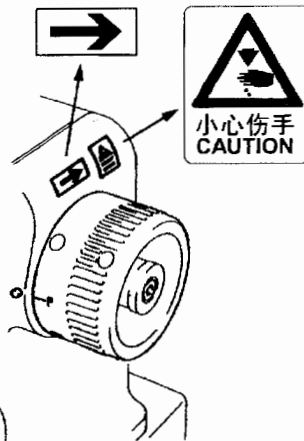
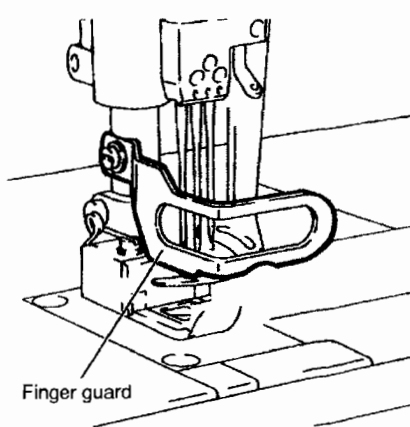
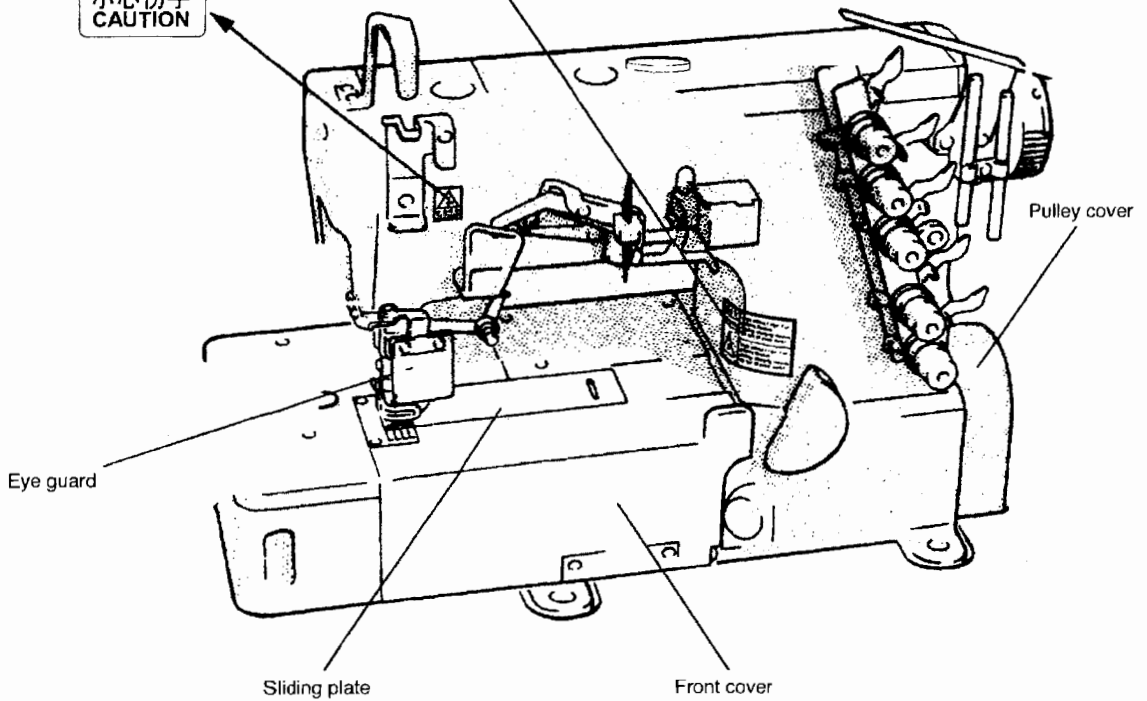

---

## 6.Protectors for safety

---

This chapter describes each protector for safety. Therefore, read and study the following carefully.

### CAUTION

#### **Protectors for safety**

##### (1)Eye guard

 Never leave the eye guard open.

For the safety of eyes, do not operate the machine with the eye guard open. The eye guard will prevent any pieces of the broken needle from getting into your eyes if the needle should break during sewing.

##### (2)Finger guard

 Never insert any of your fingers.

To prevent the needle that moves up and down from contacting any of your body, the finger guard is installed close to the needle. However, there is clearance above the finger guard for easy threading. Be careful that the needle may penetrate any of your fingers if you insert it into this clearance.

##### (3)Pulley cover

 Never remove.

The machine pulley and V belt are covered with the pulley cover. The machine pulley and the V belt rotate at high speed during sewing. To prevent accidents, operate the machine with the pulley cover installed in place.

##### (4)Pulley

Check the direction in which the machine pulley rotates. It should rotate clockwise as seen from the pulley.

##### (5)Presser foot

 Never insert any of your fingers.

There is a clearance of more than 5mm between the top surface of the needle plate and the presser foot.

Be careful that none of your fingers are caught in this clearance. Never insert any of your fingers under the presser foot when raising the presser foot with the knee switch or automatically raising it with the treadle.

##### (6)Front cover

 Never leave the front cover open.

The looper travels left to right while drawing an arc as seen from the front of the machine. To prevent the looper from contacting any part of your body, be sure to operate the machine with the front cover closed securely.

##### (7)Sliding plate

 Never leave the sliding plate open.

The looper thread take-up rotates in order to supply the required amount of looper thread during sewing. To prevent the looper thread take-up from contacting any of your body, be sure to operate the machine with the sliding plate closed securely.

# Schematic diagram of the machine table

Cut the table referring to the diagram.

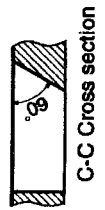
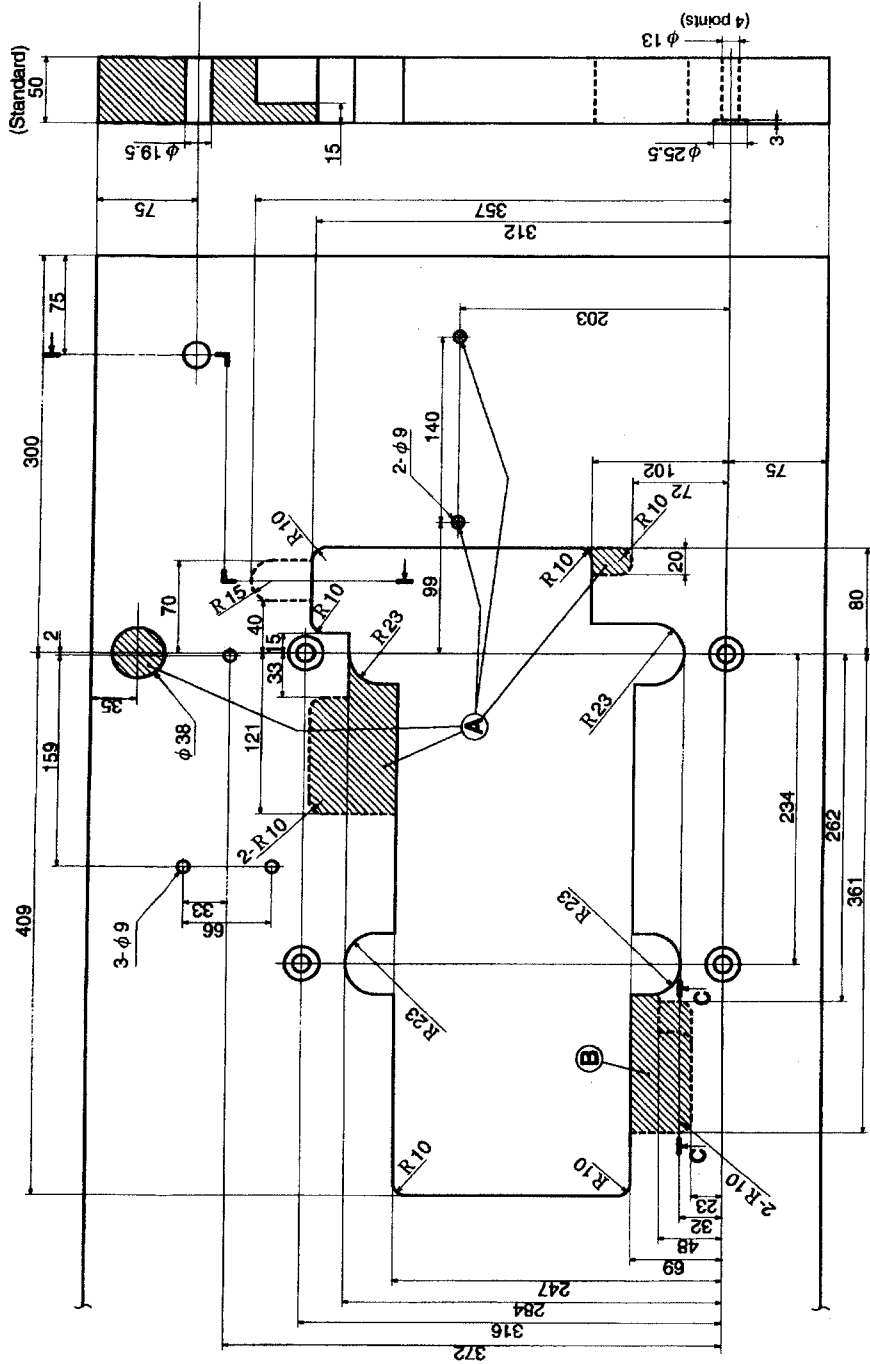

- Note 1) If you use UT device, cut area (A).
- Note 2) If the machine is equipped with FT device, cut area (B).
- Note 3) The dimension is used for positioning the hole (3-φ9) for Panais, Mitsubishi or Hitachi motor installation.

## Assembling the machine rest board

Assemble the components comprising the machine rest board by referring to the illustration below. Be sure to secure all rods, nuts and bolts firmly with no shade.

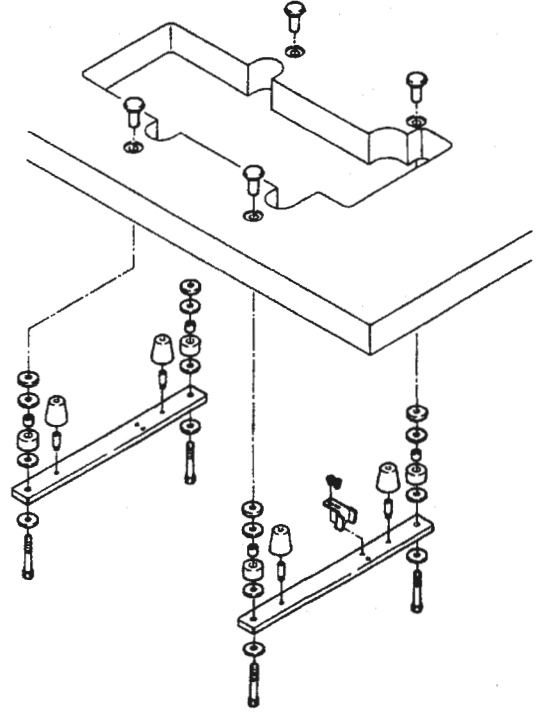

## Lubrication

### WARNING

 When lubricating the machine and/or replacing the oil, use Pegasus recommended oil. Using other oils may damage the machine.

#### 1. Oil

Use the following oil.

Pegasus designated oil: HIGH SPEED SEWING MACHINE OIL  
or Equivalents: ESSOTEX SM22 manufactured by Exxon Mobil.

#### 2. To fill the machine with oil

Remove cap 1.

Add the oil until the oil level (see oil gauge 2) reaches (H).

After filling the tank with oil, replace cap 1.

#### 3. Required amount of oil

(H) on oil gauge 2: Upper limit

(L) on oil gauge 2: Lower limit

The oil level should always lie between (H) and (L).

#### 4. Manual lubrication

### WARNING

 Always turn off the power and unplug the machine when you apply oil by hand.

Apply two or three drops of oil to needle bar 3 by hand when the machine is used for the first time or left unused for some time.

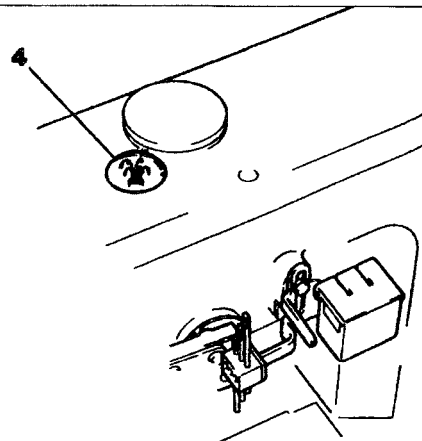
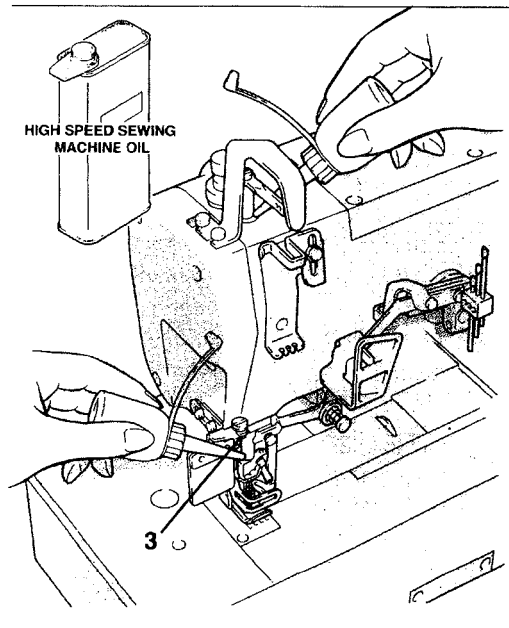
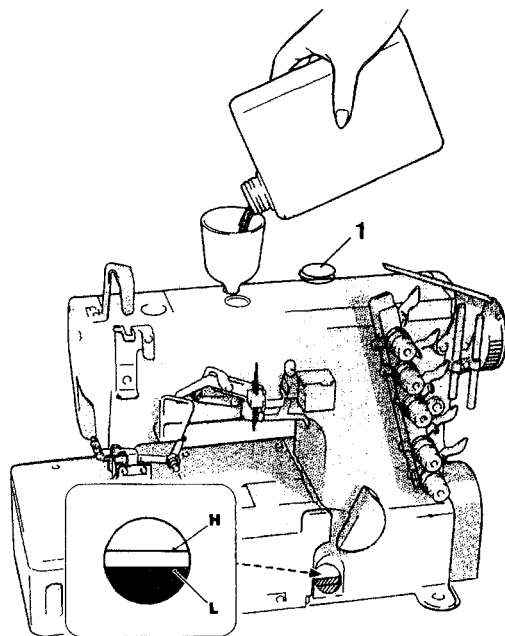

#### 5. Checking oil circulation

Once the machine has been properly filled with oil, press the machine treadle to run the machine and check oil gauge window 4 to see if the oil is flowing.

## Silicone oil for H.R. device

### CAUTION

 Always turn off the power and unplug the machine when you fill the HR device with silicone oil.

Fill silicone oil tanks 1,2 with silicone oil.

To prevent thread breakage or fabric damage, add the silicone oil before it is too low.

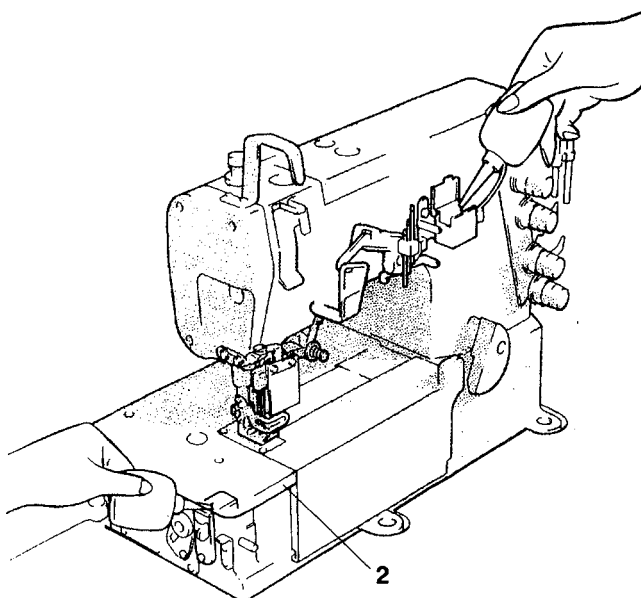

## Threading

### ⚠ CAUTION

Always turn off the power and unplug the machine when you thread the machine.

1. Open eye guard 1 and covers 2,3 and 4.

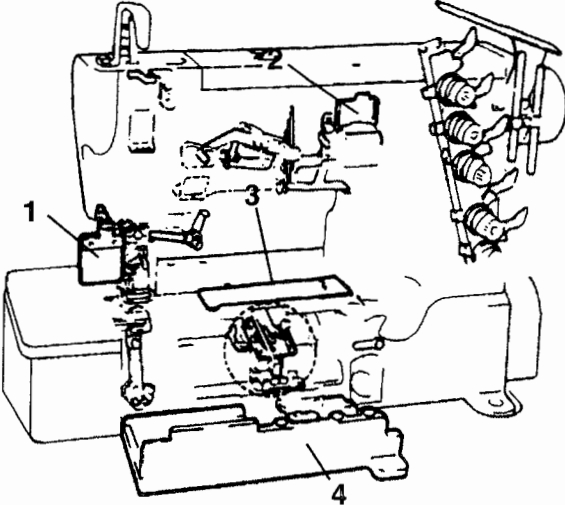

2. Press lever 5 and bracket 6 comes out toward you. After threading, press bracket 6 into place.

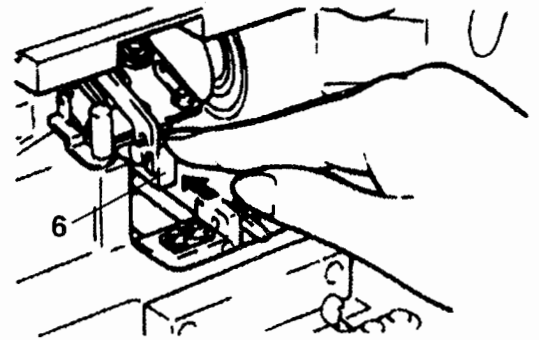
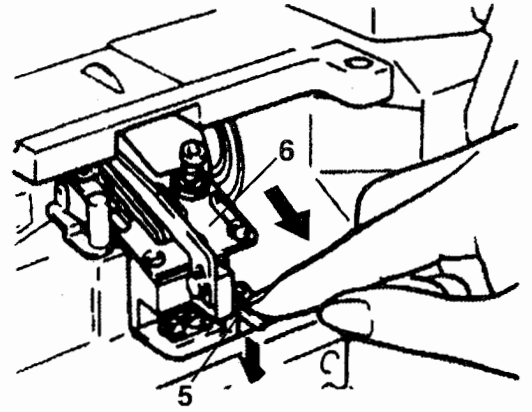

### 3. In case the machine is threaded previously

Be sure to thread the machine correctly by referring to the threading diagram. (See page 34).

**A:** Knot the preset thread and the thread being used together to thread the machine.

#### **B: Needle thread**

Trim the knots off neatly before passing through the eye of the needle to thread.

#### **C: Looper thread, Top cover thread**

Trim the knots off neatly after passing through the eye of the looper.

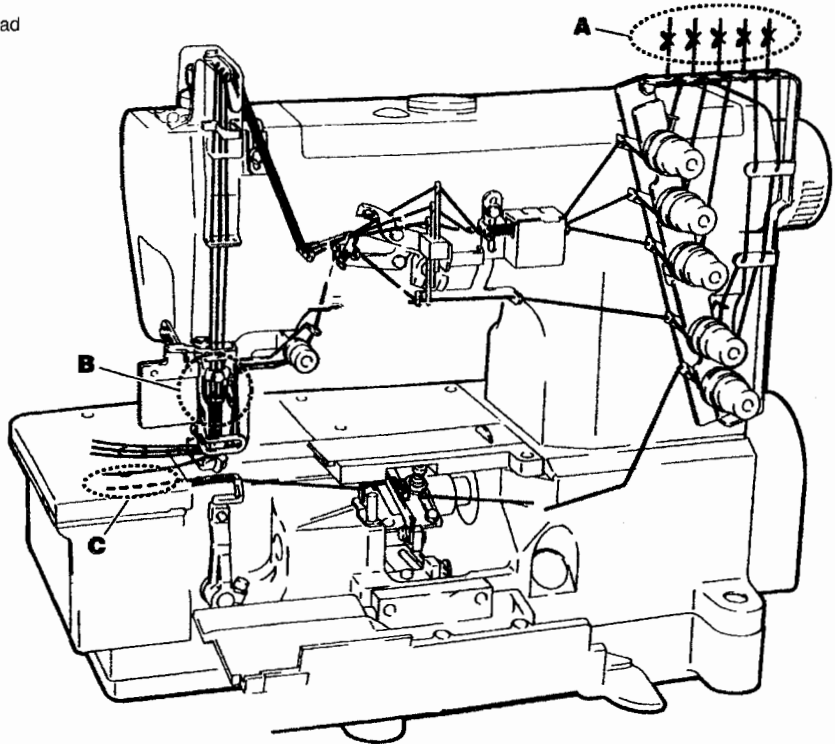



#### 4. In case the machine is threaded previously

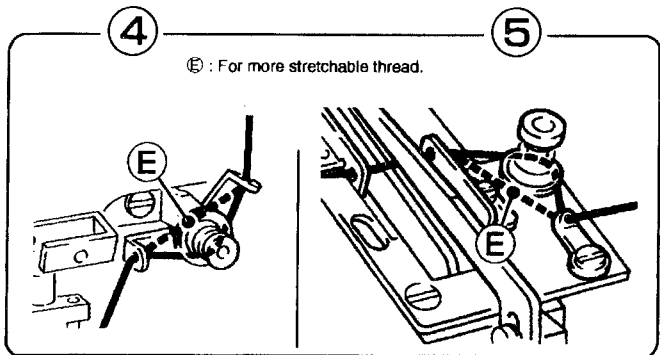
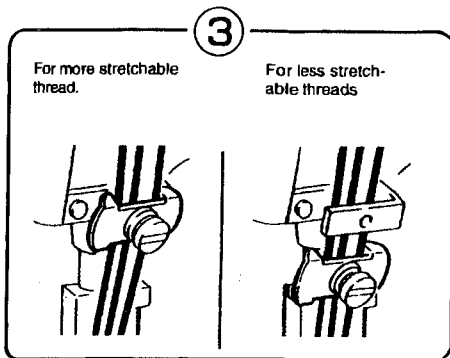
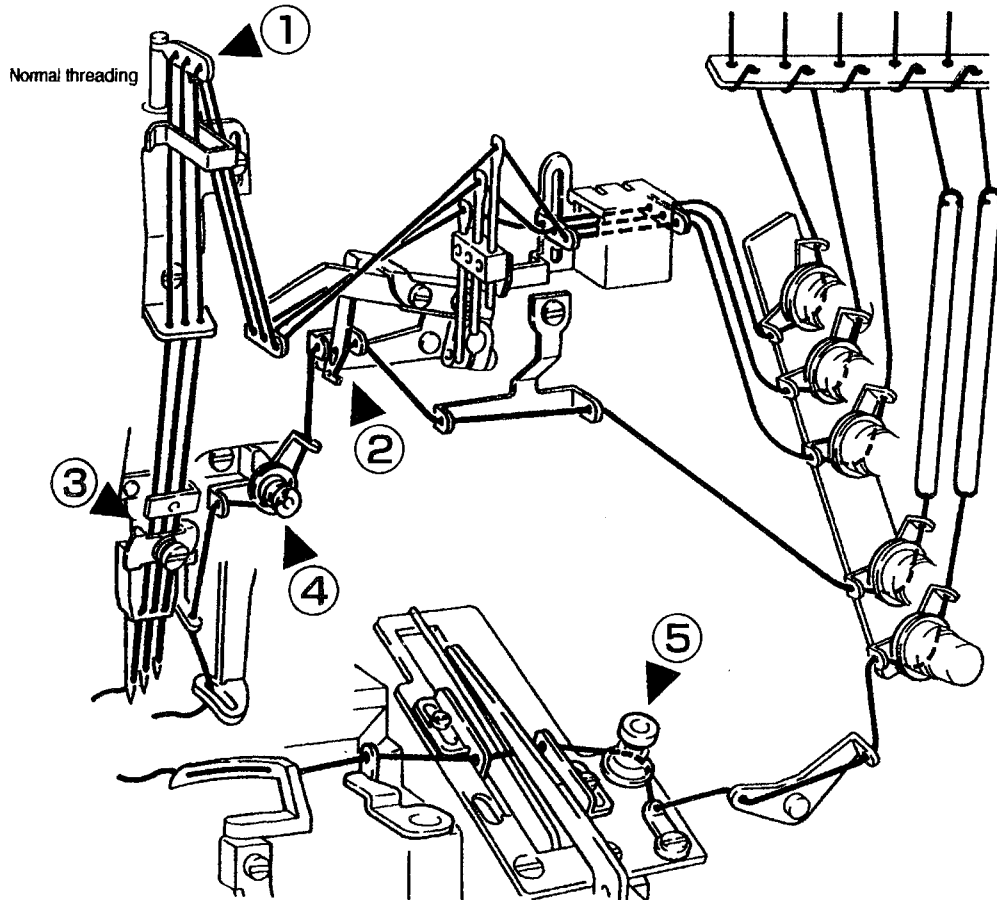
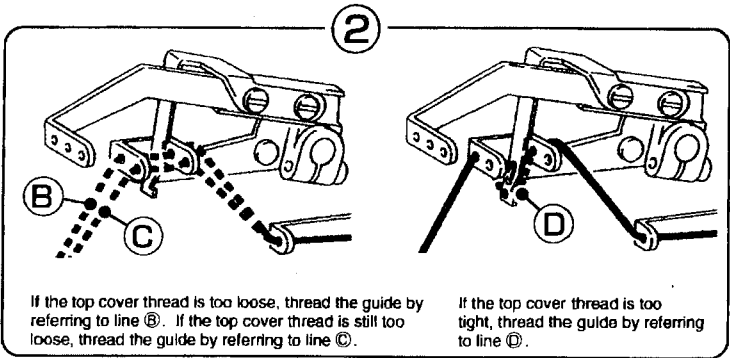
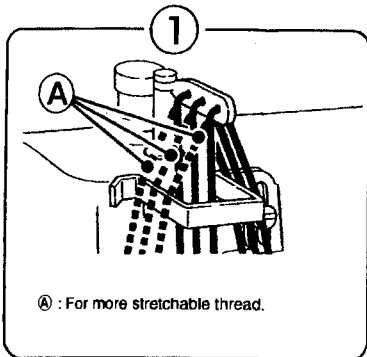

## Adjusting presser foot pressure

The presser foot pressure should be as light as possible, yet sufficient to feed the fabric correctly and provide the uniform stitch formation.

Loosen nut 1. Adjust the presser foot pressure. Adjustment is made by turning screw 2 clockwise or counterclockwise. Tighten nut 1.

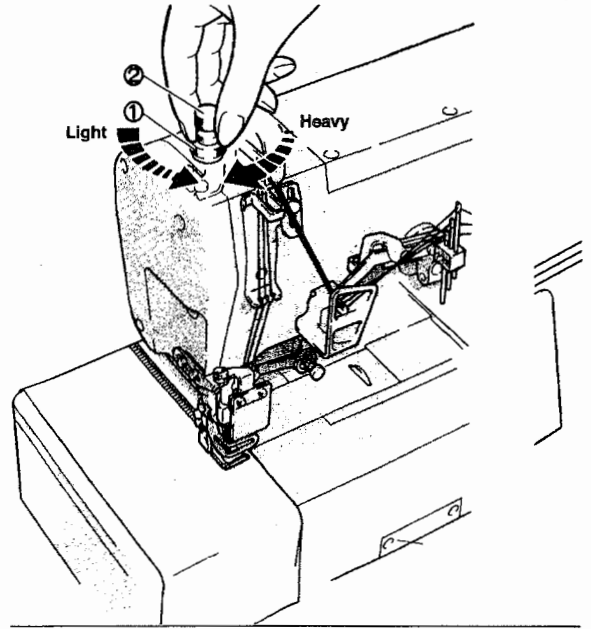

## Adjusting the differential feed ratio

1. Loosen nut 3 for the differential feed ratio adjustment.  
To increase the differential feed ratio, lower lever 4.  
The finished fabric is shrunk.  
To decrease the differential feed ratio, raise lever 4.  
The finished fabric is stretched.
2. After this adjustment tighten nut 3.

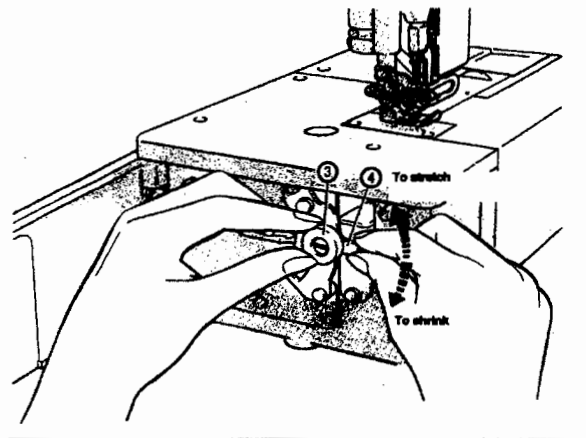

## Adjusting stitch length

### CAUTION

Always turn off the power and unplug the machine when adjusting the stitch length.

1. While pressing the push button 5, turn the handwheel 6 to seek the position at which the push button 5 goes further into the depth.
2. Then, keeping the push button 5 pressed, turn the handwheel 6 and set the desired scale to the aligning mark A.

#### Note

Stitch length adjustment must only be made after the differential feed ratio has been changed.

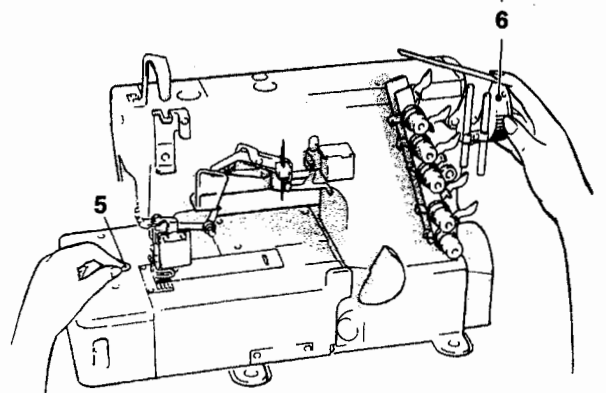
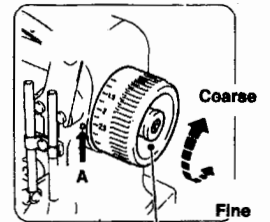

## Adjusting the thread tension

To obtain the proper thread tension, adjust needle thread tension knobs 1, top cover thread tension knobs 2 and looper thread tension knob 3.

To tighten the thread, turn each knob clockwise.

To loosen the thread, turn each knob counterclockwise.

Each thread tension should be as light as possible, yet be sufficient to produce balanced and beautiful stitches.

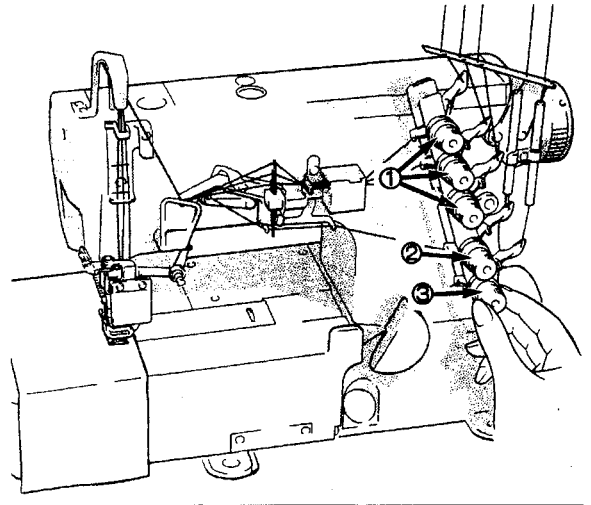
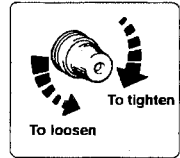

## Cleaning the machine

### CAUTION

 Always turn off the power and unplug the machine when you clean the machine.

1. Open front cover 4 and slide plate 5. Loosen screws 6 and remove needle plate 7.
2. Clean the grooves of the needle plate and the area around the feed dogs.
3. Replace needle plate 7 with screws 6. Then close front cover 4 and slide plate 5.

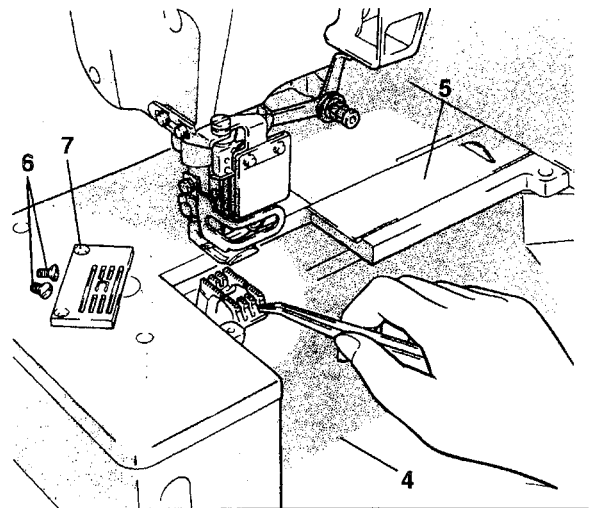

## Replacing the needle

### CAUTION

 Always turn off the power and unplug the machine when you replace the needle(s).

1. Loosen screw(s) 1 using a red-handled key wrench (1.5mm).
2. Remove the old needle(s) by using a pincette (provided as accessories).
3. Fix the needle so that its scarf faces the rear side of machine.
4. Insert a new needle into the needle hole as far it will go by using a pincette.
5. Tighten screw(s) 1 using a red-handled key wrench (1.5mm).

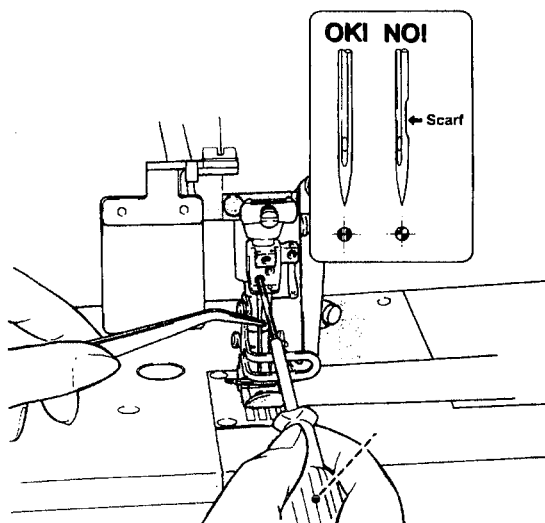
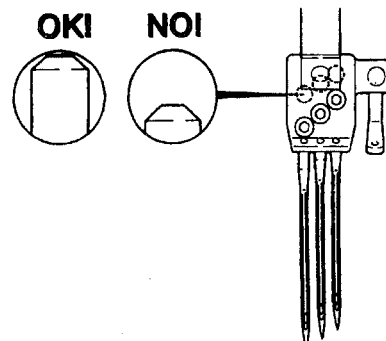

## Oil replacement

Replace the oil one month after the first use and thereafter every six months. If you keep using the old oil, it may cause the damage to the machine.

## To drain the oil

1. Drain the by removing screw 2 on the left side of the oil pan.
2. Tighten screw 2 after draining.

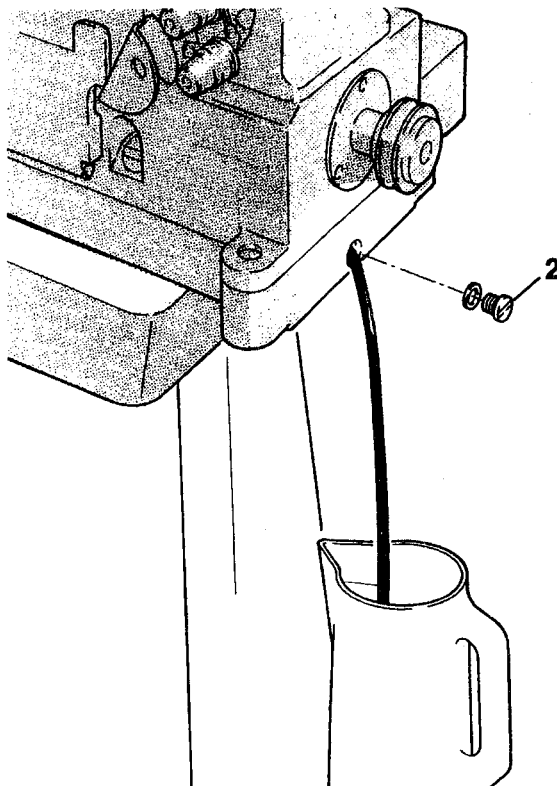

## Checking and cleaning the oil filter

### CAUTION

 Always turn off the power, unplug the machine and then well-qualified technicians should check and clean the oil filter.

Check and clean the oil filter every six months.





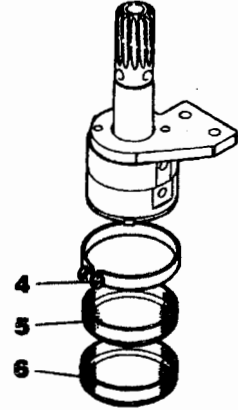
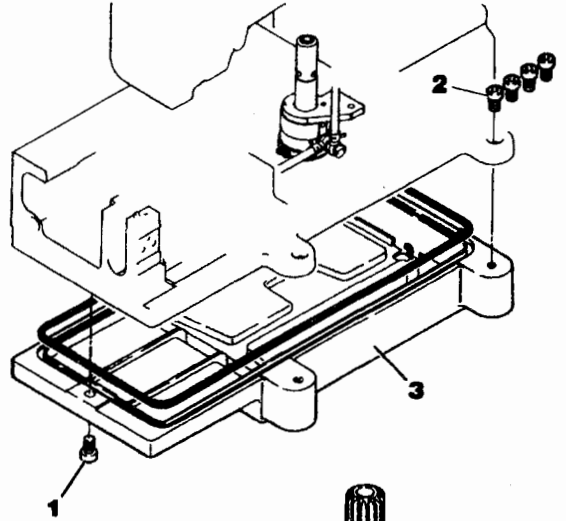

To check and clean the oil filter

1. Remove screws 1 and 2. Remove oil reservoir 3.
2. Loosen screw 4. Remove inner and outer filters 5 and 6.  
Then check and/or clean these filters.
3. Reinstall oil reservoir 3, filters 5 (inner) and 6 (outer).



### Adjustment dimentions

(mm)

	×□□□								
F1F-U356/NN	<b>224</b>	<b>10.2</b>	<b>4.5~5.1</b>	<b>8.3~8.7</b>	<b>4.5~5.0</b>	<b>17.0</b>	<b>0.8~1.2</b>		
C356/NN	<b>232</b>	<b>9.8</b>	<b>4.4~4.7</b>	<b>8.3~8.7</b>	<b>4.5~5.0</b>	<b>17.0</b>	<b>0.8~1.2</b>		
	<b>248</b>	<b>8.9</b>	<b>3.6~3.9</b>	<b>8.3~8.7</b>	<b>4.5~5.0</b>	<b>17.0</b>	<b>0.8~1.2</b>		
	<b>256</b>	<b>8.5</b>	<b>3.2~3.5</b>	<b>8.3~8.7</b>	<b>4.5~5.0</b>	<b>17.0</b>	<b>0.8~1.2</b>		
	<b>264</b>	<b>8.1</b>	<b>2.8~3.1</b>	<b>8.3~8.7</b>	<b>4.5~5.0</b>	<b>17.0</b>	<b>0.8~1.2</b>		
	<b>348</b>	<b>9.4</b>	<b>3.6~3.9</b>	<b>8.3~8.7</b>	<b>4.5~5.0</b>	<b>17.0</b>	<b>0.8~1.2</b>		
	<b>356</b>	<b>8.5</b>	<b>3.2~3.5</b>	<b>8.3~8.7</b>	<b>4.5~5.0</b>	<b>17.0</b>	<b>0.8~1.2</b>		
	<b>364</b>	<b>8.1</b>	<b>2.8~3.1</b>	<b>8.3~8.7</b>	<b>4.5~5.0</b>	<b>17.0</b>	<b>0.8~1.2</b>		

### Comparison table of equivaent sizes

Japanese size (Organ)	#	9	10	11	14	16	18	21
Metric size (Schmetz)	Nm	65	70	75	90	100	110	130

### Standard needle

	×□□□	Organ UY128GAS
F1F-U356/NN C356/NN	<b>224</b>	<b>9S</b>
	<b>232</b>	<b>9S</b>
	<b>248</b>	<b>9S</b>
	<b>256</b>	<b>9S</b>
	<b>264</b>	<b>9S</b>
	<b>348</b>	<b>10S</b>
	<b>356</b>	<b>10S</b>
	<b>364</b>	<b>10S</b>

F1F Series subclass specifications

F1F Series



Application	Subclass	Number of needles	Number of needles	Needle space(mm)	Max. Stitch length (mm)	Diff. Feed ratio	Presser foot lift (mm)	Max. speed (rpm)	Equipments with special functions	Remarks
Basic model	F1F-U356/NN	2	4	2.4 • 3.2 • 4 • 4.8 • 5.6 • 6.4	4.4	0.65~1.3	6.3	6000	D/TD/UT/RP	
		3	5	4.8 • 5.6 • 6.4			5			
Sewing rolled-edge	F1F-C356/NN	2	4	2.4 • 3.2 • 4 • 4.8 • 5.6 • 6.4	4.4	0.65~1.3	6.3	6000	D/TD/TK/RP	
		3	5	4.8 • 5.6 • 6.4			5			
Cover seaming	-	2	4	4 • 4.8 • 5.6 • 6.4	4.4	0.65~1.3	6.3	6000	UT/RP	
		3	5	4.8 • 5.6 • 6.4			5			
	-	2	4	4 • 4.8 • 5.6 • 6.4	4.4	0.65~1.3	6.3	6000	UT/RP	
		3	5	4.8 • 5.6 • 6.4			5			
Elasticlance cd rd.	-	2	4	2.4 • 3.2 • 4 • 4.4 • 5.6 • 6.4	4.4	0.65~1.3	6.3	5000	TK	
		3	5	4.8 • 5.6 • 6.4			5			
	-	2	4	3.2 • 4 • 4.8 • 5.6 • 6.4	4.4	0.65~1.3	6.3	5000	TK	
		3	5	4.8 • 5.6 • 6.4			5			
Lace sewing	-	2	4	3.2 • 4 • 4.4 • 5.6 • 6.4	4.4	0.65~1.3	6.3	6000	TK	
		3	5	4.8 • 5.6 • 6.4			5			
Bottom folding seam	-	2	4	4 • 4.8	4.4	0.65~1.3	6.3	6000	UT/RP	
		3	5	5.6 • 6.4			5			
Having three functions	-	2	4	3.2 • 4 • 4.4 • 5.6 • 6.4	4.4	0.65~1.3	6.3	6000		
		3	5	4.8 • 5.6 • 6.4			5			
For hesvy materials	-	2	4	5.6 • 6.4	4.4	0.65~1.3	6.3	5000	UT	
		3	5	5.6 • 6.4						

When it is equipped with direct drive motor(D) and some equipments with special functions (D/TD/TU/RTF/TK/RP),the highest speed is 4500 rmp

# GAUGE PARTS LIST

											
MACHINE TYPE /SPEC	GAUGE	NEEDLE HOLDER	NEEDLE PLATE	MAIN FEED DOG	DIFF FEED DOG	PRESSER FOOT ASSY.	LOOPER	NEEDLE GUARD (FRONT)	NEEDLE GUARD (REAR)	SPREADER	NEEDLE
F1F-U356/NN	356	JINBF31016257518	JINBF31016257018B56	JINBF31016257207	JINBF31016257259	JINBF31016257461	JINBF31016257550	JINBF31016257553	BF31016257551B	JINBF31016257565	JINBF3101611JZ
F1F-U364/NN	364	JINBF3101625751864	JINBF3101625701864	JINBF31016257207	JINBF31016257259	JINBF3101625746164					
F1F-C356/NN	356	JINBF31016257518	JINBF3101602BB257033	JINBF3101602BB257216	JINBF3101602BB257262	JINBF3101602BB257321					
F1F-C364/NN	364	JINBF3101625751864	JINBF3101602BB25703364	JINBF3101602BB257216	JINBF3101602BB257262	JINBF3101602BB25732164					
F1F-E356/ND	356	JINBF31016257518	JINBF3101605257053A	JINBF3101605257222	JINBF3101605257268	JINBF3101605257331					
F1F-E356/ND	364	JINBF3101625751864	JINBF3101605257053A64	JINBF3101605257222	JINBF3101605257268	JINBF310160525733164					
F1F-U356/SN	356	JINBF31016257518	JINBF31016257018B56	JINBF31016257207	JINBF31016257259	JINBF31016257461					
F1F-U364/SN	364	JINBF3101625751864	JINBF3101625701864	JINBF31016257207	JINBF31016257259	JINBF3101625746164					