

ENGLISH

INSTRUCTION MANUAL



CONTENTS

1. SPECIFICATIONS	1
1-1 Specifications of the machine head	1
1-2 Specifications of the control box	1
2. CONFIGURATION	2
2-1 Sewing machine main unit	2
2-2 Operation panel	3
3. INSTALLATION	4
3-1 Caution at the time of set-up	4
3-2 Assembling the pedal section of the stand	5
3-3 Assembling the table	6
3-4 Connecting the power cable	7
3-5 Installing the sewing machine main unit	7
3-6 Installing the cover	8
3-7 Installing the stopper for tilt prevention	8
3-8 Installing the operation panel	8
3-9 Connecting the cords	9
3-10 Installing the throat plate auxiliary plate	10
3-11 Installing the thread guide rod	10
3-12 Installing the thread stand	11
3-13 Assembling the table for work (WORK TOP TABLE)	11
4. PREPARATION BEFORE OPERATION	12
4-1 Attaching the needle	12
4-2 Threading the needle-thread	12
4-3 Winding the bobbin thread	13
4-4 Setting the bobbin into the bobbin case	13
4-5 Attaching and removing the bobbin case	14
4-6 Adjusting the thread tension	14
4-7 Adjusting the thread take-up spring	14
4-8 Adjusting the stitch guide	14
5. OPERATION OF THE SEWING MACHINE (SEMI-AUTOMATIC BASIC VOLUME)	15
5-1 Data input screen	15
5-2 Sewing screen	17
5-3 Details data input screen	18
5-4 Feed amount	20
5-5 Basic operation of the sewing machine	21
5-6 Basic change of the set value	25
(1) Changing the sewing speed <Max. sewing speed setting>	25
(2) Changing the pitch <Pitch setting>	25
(3) Changing the needle thread tension <Needle thread tension setting>	26
(4) Changing the shirring amount <Shirring amount setting>	27
(5) Changing the shirring amount of auxiliary feed <Auxiliary feed shirring amount setting>	27

5-7 Creating the pattern <Pattern creation>	28
5-8 Deleting the pattern <Pattern deletion>	29
6. OPERATION OF THE SEWING MACHINE	
(SEMI-AUTOMATIC APPLICATION VOLUME)	31
6-1 Correcting the pattern	31
(1) Changing the needle thread tension of specified step	
<Compensation thread tension setting>	31
(2) Changing the pitch of specified step <Compensation pitch setting>	32
(3) Increasing/decreasing the shirring amount of all steps	
<Shirring amount increase/decrease setting>	33
(4) Increasing/decreasing the shirring amount immediately after changeover of step	
<Compensation shirring amount setting>	34
(5) Adding the step <Step addition>	35
(6) Deleting the step <Step deletion>	37
(7) Changing the start position of program <Start position change>	39
(8) Mirroring the program of one sleeve and creating the program of the other sleeve	
<Mirroring function>	41
(9) Changing the top notch position of program <Top notch position change>	42
(10) Naming the pattern <Data name setting>	44
6-2 Copying the pattern <Pattern copy>	45
(1) Pattern copy in semi-automatic mode <Copy to semi-automatic>	45
(2) Pattern copying from semi-automatic to fully-automatic <Copy to fully-automatic>	46
6-3 Creating the new pattern <New pattern creation>	47
6-4 Using the other functions	49
(1) Directly calling the pattern from the sewing screen <Direct pattern selection>	49
(2) Adjust the STEP SELECTION button to the shape of sleeve <Measure function>	49
7. OPERATION OF THE SEWING MACHINE	
(FULLY-AUTOMATIC BASIC VOLUME)	50
7-1 Data input screen	50
7-2 Sewing screen	52
7-3 Detailed data input screen	53
7-4 Feed amount	55
7-5 Basic operation of the sewing machine	56
7-6 Changing the basic set value	59
(1) Changing the sewing machine speed <Max. sewing speed setting>	59
(2) Changing the pitch <Pitch setting>	60
(3) Changing the needle thread tension <Needle thread tension setting>	60
(4) Changing the shirring amount <Shirring amount setting>	61
(5) Changing the shirring amount of auxiliary feed <Auxiliary feed shirring amount setting>	61
7-7 Creating the pattern <Pattern creation>	62
7-8 Deleting the pattern <Pattern deletion>	64
8. OPERATION OF THE SEWING MACHINE	
(FULLY-AUTOMATIC APPLICATION VOLUME)	66
8-1 Correcting the pattern	66
(1) Changing the length of specified step <Length between steps setting>	66
(2) Changing the needle thread tension of specified step	
<Compensation thread tension setting>	67
(3) Changing the pitch of specified step <Compensation pitch setting>	68

(4) Increasing/decreasing the shirring amount of all steps <Shirring amount increase/decrease setting>	70
(5) Increasing/decreasing the shirring amount immediately after changeover of step <Compensation shirring amount setting>	71
(6) Adding the step <Step addition>	72
(7) Deleting the step <Step deletion>	74
(8) Changing gent's/ladies' wear classification <Gent's/ladies' selection>	76
(9) Changing the size <Size change>	77
(10) Setting the offset value of grading <Grading value setting>	78
(11) Changing the start position of program <Start position change>	79
(12) Mirroring the program of one sleeve and creating the program of the other one <Mirroring function>	80
(13) Changing the top notch position of program <Top notch position change>	82
(14) Naming the pattern <Data name setting>	83
8-2 Copying the pattern <Pattern copy>	84
(1) Pattern copy in the fully-automatic <Copy to fully-automatic>	84
(2) Pattern copy from fully-automatic to semi-automatic <Copy to semi-automatic>	86
8-3 Creating a new pattern <New pattern creation>	87
8-4 Using other functions	89
(1) Directly calling the pattern from sewing screen <Direct pattern selection>	89
(2) Re-registering the length between steps <Measure function>	90
9. OPERATION OF THE SEWING MACHINE	
(MANUAL BASIC VOLUME)	91
9-1 Data input screen	91
9-2 Sewing screen	92
9-3 Details data input screen	93
9-4 Basic operation of the sewing machine	94
9-5 Changing the basic set value	95
(1) Changing the sewing speed <Max. sewing speed setting>	95
(2) Changing the pitch <Pitch setting>	96
(3) Changing the needle thread tension <Needle thread tension setting>	97
10. OPERATION OF THE SEWING MACHINE	
(MANUAL APPLICATION VOLUME)	98
10-1 Changing the detailed set value	98
(1) Changing the operating mode of auxiliary pedal <Auxiliary pedal operation selection>	98
(2) Changing the auxiliary feed operating mode <Auxiliary feed mode selection>	99
(3) Setting the auxiliary feed interlock mode <Auxiliary feed interlock mode setting>	101
(4) Setting the range of shirring amount <Shirring amount range setting>	103
(5) Setting the compensation thread tension <Compensation thread tension setting>	104
11. USING COUNTER	105
11-1 Setting procedure of the counter	105
11-2 Count-up releasing procedure	108
12. REGISTERING THE PATTERN TO DIRECT BUTTON	108
12-1 How to register	108
12-2 Register state at the time of your purchase	109
13. CHANGING SEWING MODE	110
14. CHANGING MEMORY SWITCH DATA	111
14-1 Changing procedure of memory switch data	111
14-2 Memory switch data list	112

14-3 Explanation of compensation thread tension	118
(1) Explanation of compensation tension manual (numerical value)	118
(2) Explanation of compensation tension manual (level)	120
(3) Explanation of compensation thread tension automatic	123
14-4 Explanation of the shirring smoothing function	125
(1) Explanation of the motion of shirring smoothing function	125
(2) Setting of the shirring smoothing function	126
14-5 Explanation of the size class	127
(1) Explanation of the size class	127
(2) Size development	129
15. ERROR CODE LIST	130
16. USING COMMUNICATION FUNCTION	134
16-1 Handling possible data	134
16-2 Performing communication by using the smart media	135
16-3 Performing communication by using RS-232C	137
16-4 Take-in of the data	137
17. INFORMATION FUNCTION	140
17-1 Observing the maintenance and inspection information	140
17-2 Inputting the inspection time	142
17-3 Releasing procedure of the warning	143
17-4 Observing the production control information	144
(1) When displaying from the information screen	144
(2) When displaying from the sewing screen	145
17-5 Performing setting of the production control information	146
17-6 Observing the working measurement information	149
18. TRIAL SEWING FUNCTION	152
18-1 Performing trial sewing	152
19. PERFORMING KEY LOCK	154
20. DISPLAYING VERSION INFORMATION	156
21. USING CHECK PROGRAM	157
21-1 Displaying the check program screen	157
21-2 Performing the auxiliary pedal setting	158
21-3 Performing checking of A/D value of auxiliary pedal	159
21-4 Performing LCD check	159
21-5 Performing touch panel compensation	160
21-6 Performing the input signal check	162
21-7 Performing the output signal check	164
22. COMMUNICATION SCREEN OF MAINTENANCE	
PERSONNEL LEVEL	166
22-1 Data which are possible to be handled in case of the maintenance	166
22-2 Displaying maintenance personnel level	167
23. INFORMATION SCREEN OF THE MAINTENANCE PERSONNEL LEVEL	168
23-1 Display of error record	168

23-2 Display of the cumulative working information	169
24. MAINTENANCE	170
24-1 Replacing procedure of feed belt	170
(1) Replacing the top feed belt	170
(2) Replacing the bottom feed belt	171
(3) Replacing the bottom feed roller	171
24-2 Changing the amount of alternate vertical movement of walkingfoot and presser foot	172
(1) When making equal the amount of alternate vertical movement of walking foot and presser foot (When making the amount equal to 1.5 mm)	173
(2) When making 2.5 mm the amount of alternate vertical movement	173
24-3 Adjusting the height of the walking foot and the presser foot	174
(1) Adjusting the height of walking foot	174
(2) Adjusting the height of presser foot	174
24-4 Adjusting the needle and the hook.....	175
(1) Adjusting the height of needle bar	175
(2) Adjusting the hook	175
24-5 Adjusting the thread trimmer	176
(1) Adjusting the thread trimmer cam timing	176
(2) Adjusting the initial position of the moving knife	176
(3) Adjusting the initial position of the thread trimmer solenoid	177
(4) Adjusting the position of the moving knife and the counter knife	178
24-6 Greasing parts.....	178
25. OTHERS	179
25-1 Troubles in sewing and the corrective measures	179
26. DRAWING OF THE TABLE	180
26-1 Slant table	180
26-2 Work top table	181
26-3 Edge stopper A	182
26-4 Edge stopper B	183

1. SPECIFICATIONS

1-1 Specifications of the machine head

Sewing speed	Max. 3,500 rpm (*1)
Feed system	Intermittent belt feed by direct drive of stepping motor
Stitch length	Both top and bottom 1.5 to 6 mm
Stitch length adjustment system	Panel input
Stitch length adjustment minimum resolution	0.1 mm
Needle bar stroke	30.7 mm
Needle	DPX17 #10 to #14
Hook	Full-rotary non-lubricated horizontal-axis hook
Presser foot lift	By hand lifter : 5.5 mm, by auto-lifter : 10 mm
Amount of alternate vertical movement of presser foot/walking foot	Max. 3.5 mm
Adjustment of amount of alternate vertical movement of presser/walking foot	Slot stop position adjustment
Lubrication	Non-lubrication
Number of programs that can be inputted	99 programs
Number of steps that can be inputted (per program)	30 steps
Data mirroring	Provided
Right/left alternate sewing	Possible
Data record	Smart media
Noise	Workplace-related noise at sewing speed n=3,000 min-1 : LPA ≤ 84dB(A) Noise measurement according to DIN 45635-48-A-1

*1. The maximum sewing speed is limited in accordance with the amount of alternate vertical movement of presser foot and walking foot, and stitch length.

Limitation by the amount of alternate vertical movement of presser and walking foot

Max. sewing speed (rpm)	Amount of vertical movement of walking foot (mm)	Amount of vertical movement of presser foot (mm)
3,500	Less than 0.3	(2.7)
2,600	Not less than 0.3 to 1.5	(1.5)
2,000	Not less than 1.5 to 2.5	(2.5)
1,600	Not less than 2.5 to 3.5	(3.5)

Limitation by stitch length

Max. sewing speed (rpm)	Stitch length (mm)
3,500	1.5 to 4.0
2,500	4.1 to 6.0

1-2 Specifications of the control box

Power voltage	3-phase 200V/220V/240V	Single phase 220V/230V/240V
Frequency	50Hz/60Hz	
Rated current	2.6A/2.4A/2.2A	2.8A/2.6A/2.5A
Operating temperature/humidity	0 to 40°C, Less than 90%	

2. CONFIGURATION

2-1 Sewing machine main unit

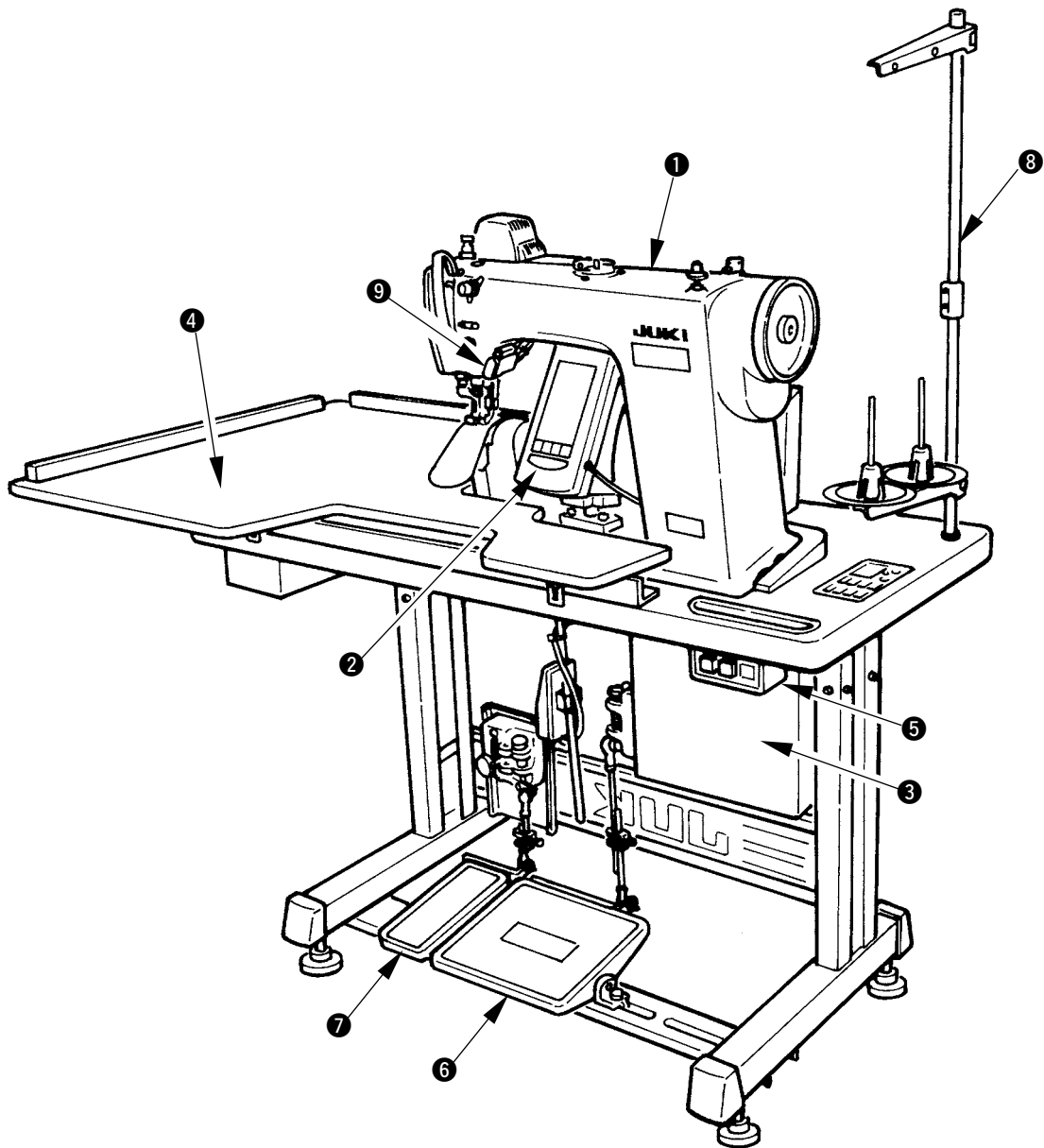

- ① Sewing machine head
- ② Operation panel
- ③ Control box
- ④ Auxiliary table (WORK TOP TABLE)
- ⑤ Power switch
- ⑥ Main pedal
- ⑦ Auxiliary pedal
- ⑧ Thread stand
- ⑨ Shirring release switch

2-2 Operation panel

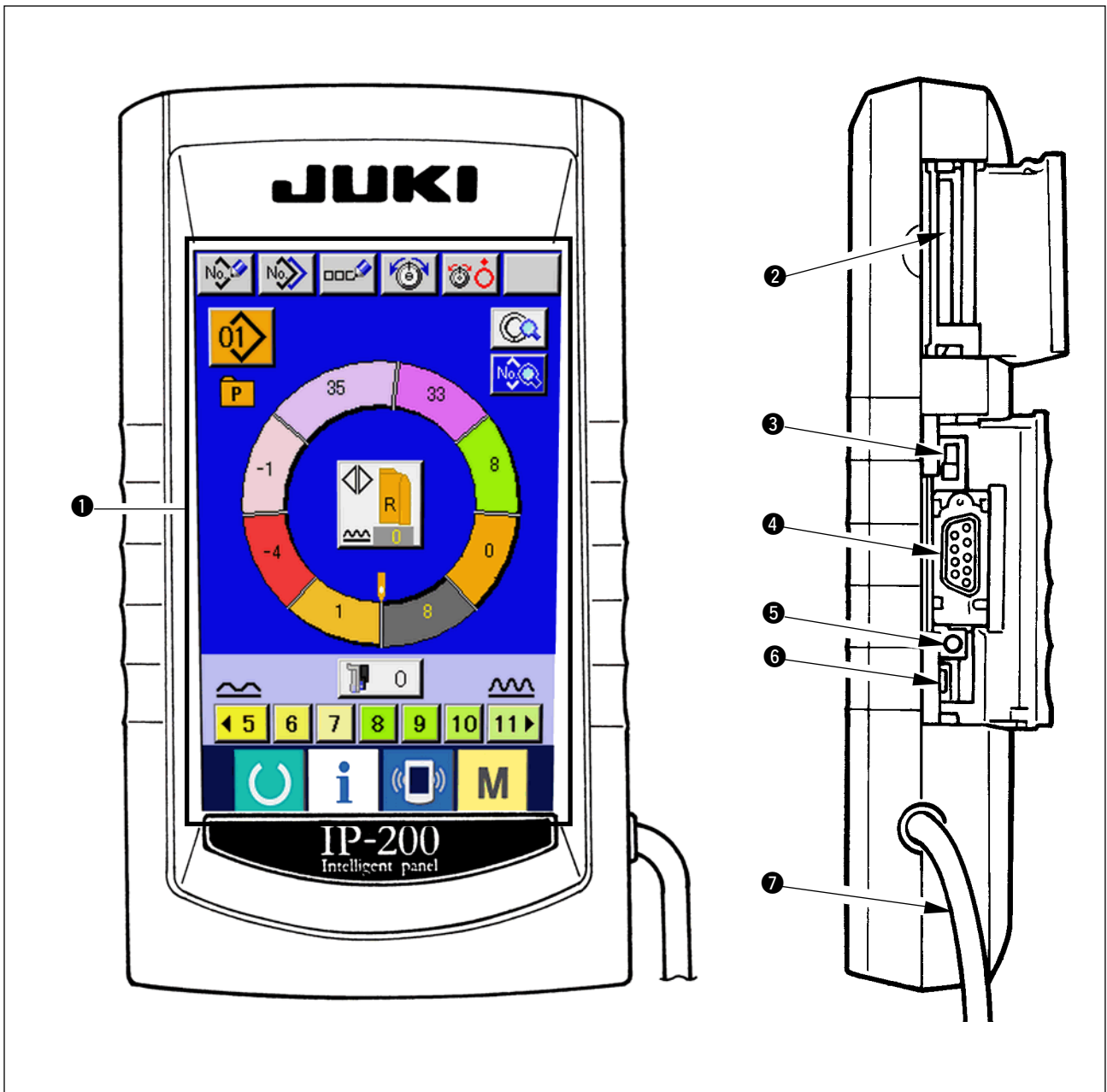

- ① Touch panel, LCD display section
- ② Smart media slot card (Use with the lid closed.)
- ③ Slide switch (Unused · OFF)
- ④ Connector for RS-232C communication
- ⑤ Variable resistor for adjusting color LCD screen contrast
- ⑥ Connector for external input
- ⑦ Cable

3. INSTALLATION

3-1 Caution at the time of set-up

1) Transporting procedure of the sewing machine

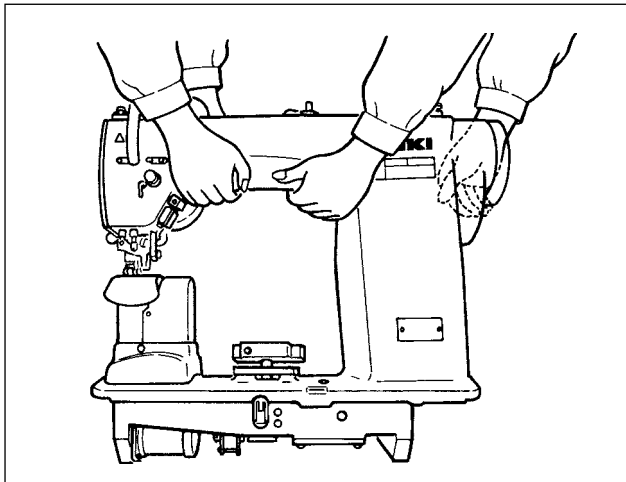

Hold and transport the sewing machine with two persons as shown in the illustration.



Do not hold the handwheel.

2) Caution when placing the sewing machine

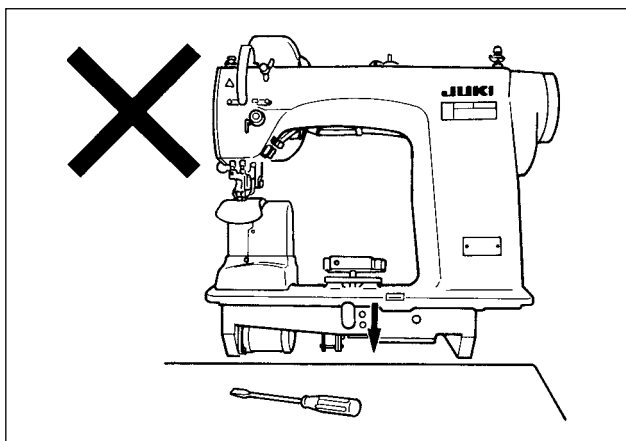

Do not put protruding articles such as the screwdriver and the like at the location where the sewing machine is placed.

3) Removing the air vent cap

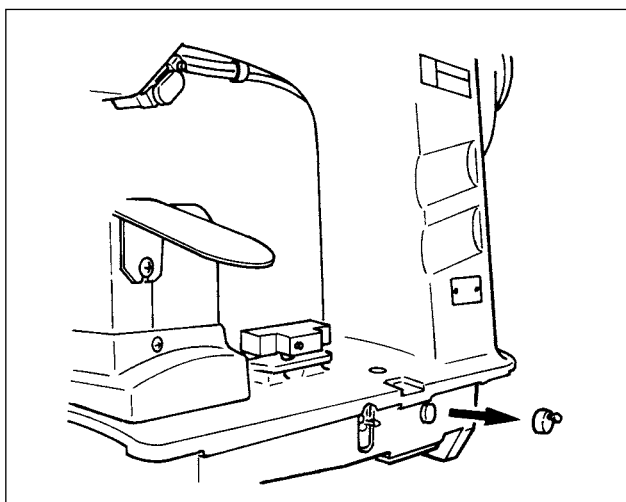

Be sure to remove the red rubber cap as shown in the illustration before operating the sewing machine. When transporting the machine head only, attach this rubber cap to the machine head.

3-2 Assembling the pedal section of the stand

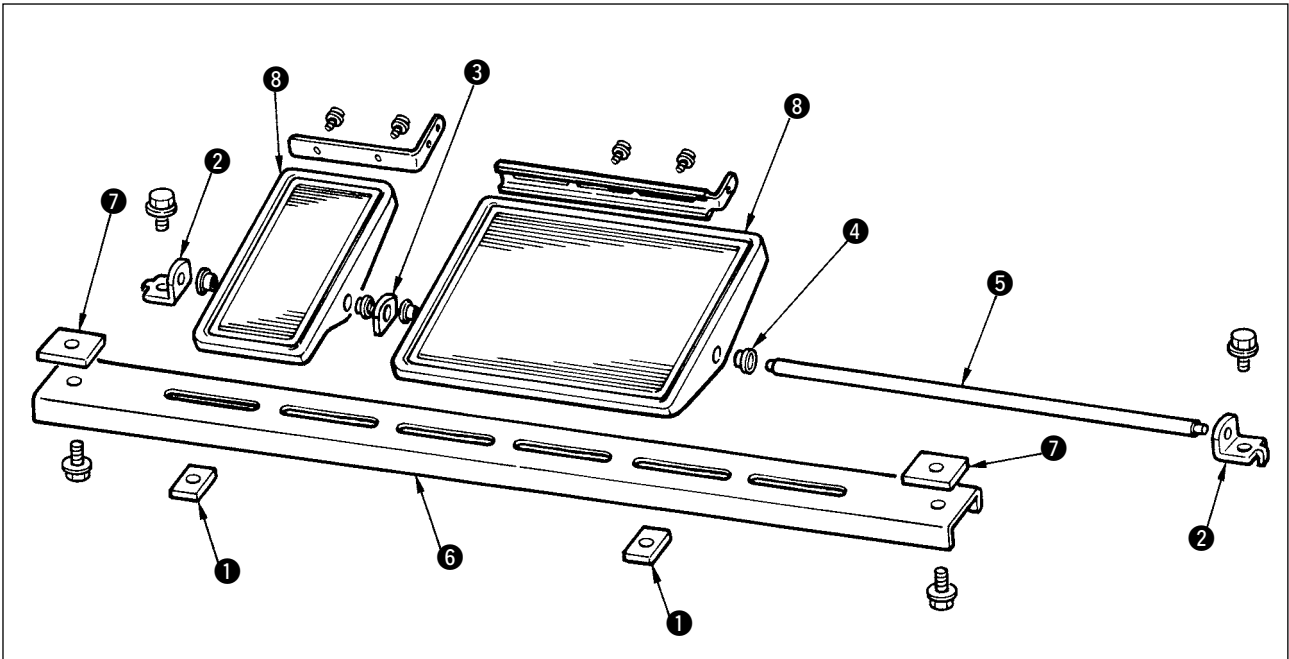

- 1) Assemble the lower strut to the stand using square nut ⑦(wide width).
- 2) Put bush ④ to the pedal ⑧ and pass it through shaft ⑤ together with shaft bearing plate ③. Then fix with pedal shaft bearing ②.
- 3) Fix pedal shaft bearing ② using square nut ① (narrow width).
- 4) Assemble the whole pedal after fully drawing it up in the left direction in the illustration.

[When using with 1-pedal]

There is the short shaft for 1-pedal in the accessories. Remove the small pedal and shaft bearing plate ③ and replace the shaft with the shaft for 1-pedal. Then the machine can be used even with 1-pedal.

3-3 Assembling the table

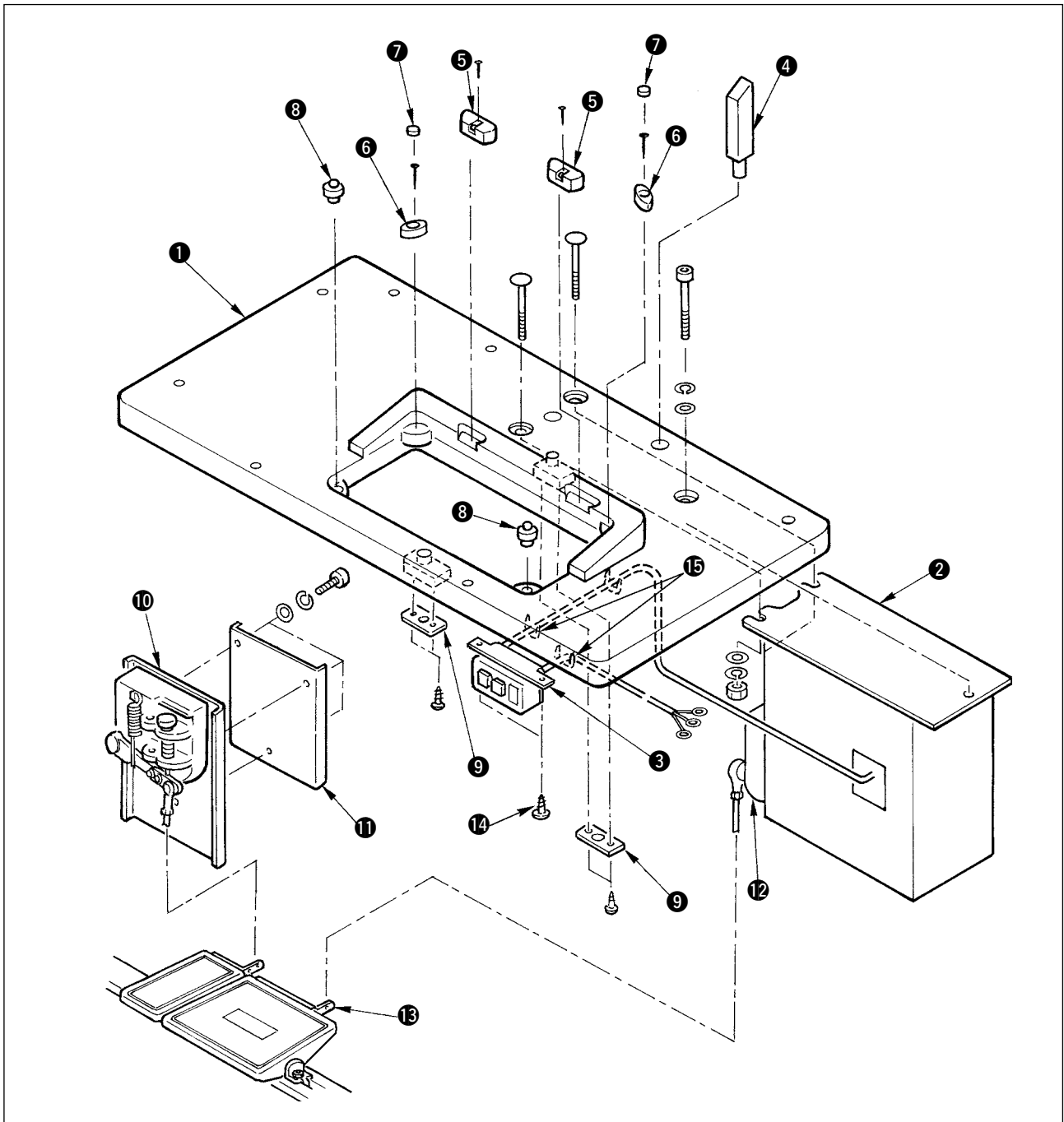

- 1) Fix hinge seats ⑤ and machine head supporting rubbers ⑥ on table ① with the nails. (Use 2 pcs. each of nail for fixing hinge seats ⑤ and 1 pc. each of nail for fixing machine head supporting rubbers.)
- 2) Attach felts ⑦ to machine head supporting rubbers ⑥.
- 3) Attach machine head supporting rubbers ⑧ to table ①.
- 4) Fix stopper plate ⑨ to the rear side of table ①.
- Caution) Be sure to install stopper plate ⑨ before installing control box ②.**
- 5) Fix control box ② and power switch ③, and fix the power cable with the staples.
- 6) Fix power switch ③ under the machine table with wood screw ⑭. Fix the cable with staple ⑮ supplied with the machine as accessories in accordance with the forms of use.
- 7) Temporarily fix the side strut so that it is put between auxiliary pedal sensor ⑩ and sensor plate ⑪.
- 8) Connect pedal (large) and pedal sensor ⑫ with connecting rod (long). Adjust the inclination of connecting rod at the position of adjusting plate ⑬.
- 9) Connect pedal (small) and auxiliary pedal sensor ⑩ with connecting rod (short). Adjust the inclination of connecting rod at the position of auxiliary pedal sensor and securely tighten the screw.
- 10) Install head supporting rod ④ on table ①.

3-4 Connecting the power cable

Connect the cable in accordance with the specifications.

- Connection of 3-phase 200V/220V/240V

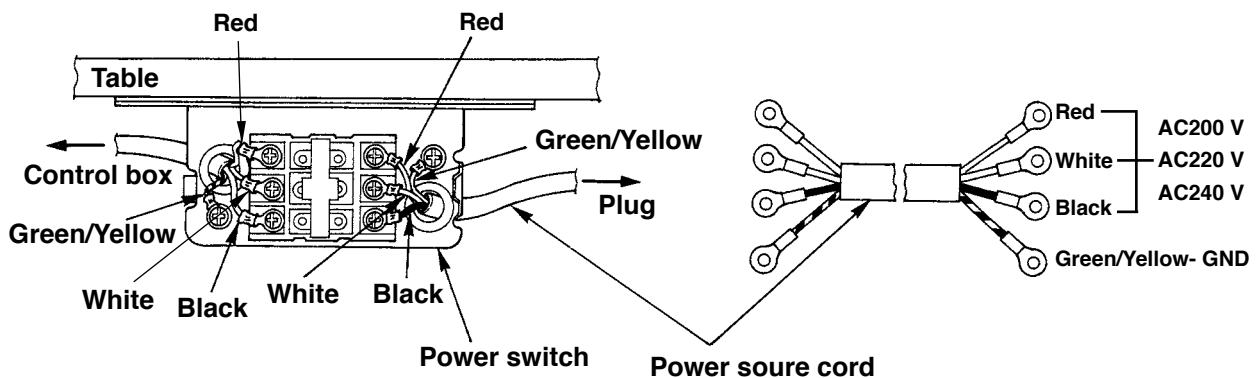

- Connection of single phase 220V/230V/240V

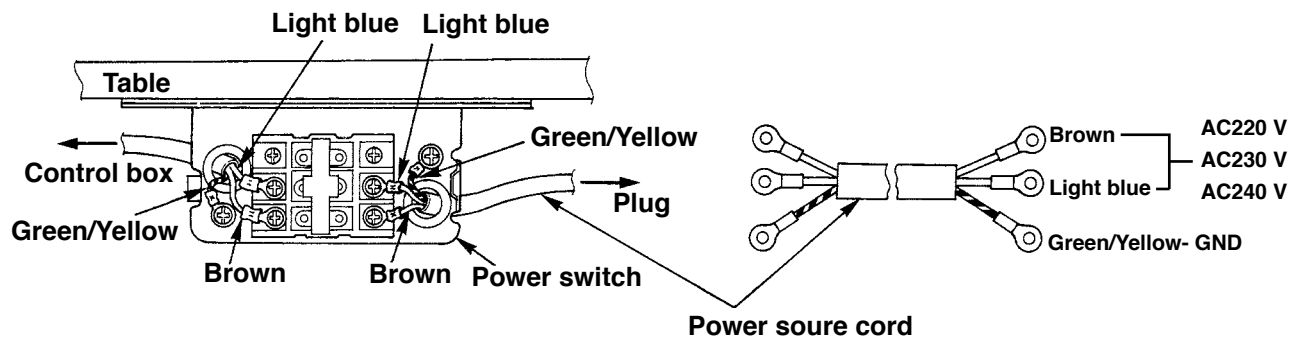

Never use the machine with the wrong power specifications.

3-5 Installing the sewing machine main unit



WARNING :

To prevent possible accidents caused by the fall of the sewing machine, perform the work by two persons or more when the machine is moved.

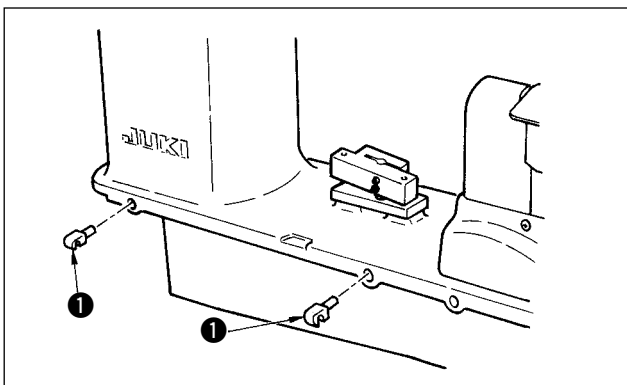

Insert hinges ❶ into the holes in the frame and place the machine head on the table.

3-6 Installing the cover



WARNING :

When tilting/raising the sewing machine head, perform the work so as not to allow your fingers to be caught in the machine. In addition, to avoid possible accidents caused by abrupt start of the machine, turn OFF the power to the machine before starting the work.

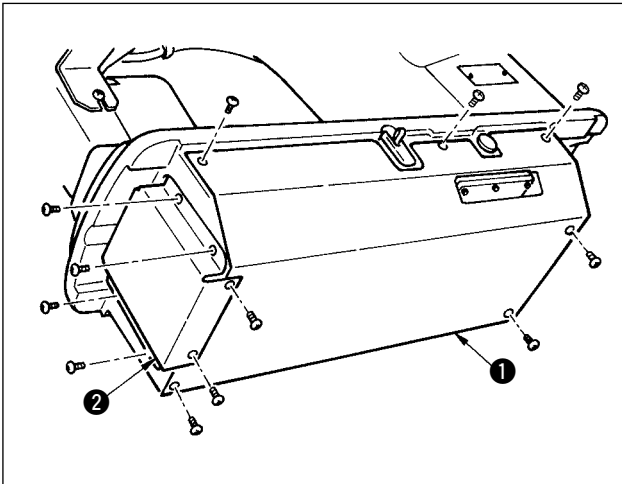

Slowly tilt the machine head and install bottom cover ① and bottom feed cover ② .

3-7 Installing the stopper for tilt prevention

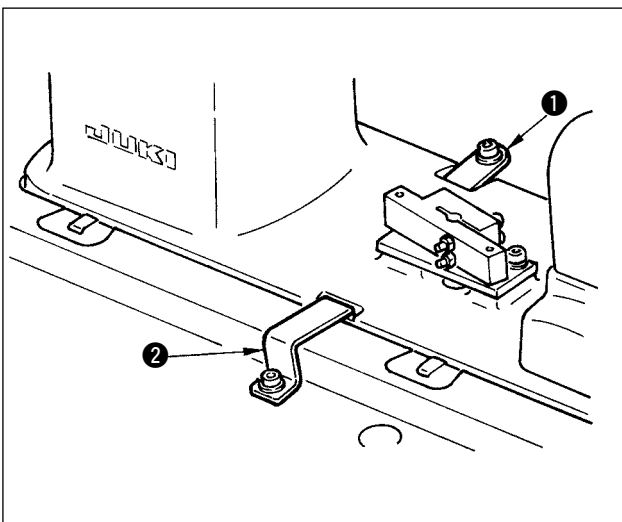

Install stopper plate A ① and stopper plate B ② for tilt prevention.

3-8 Installing the operation panel

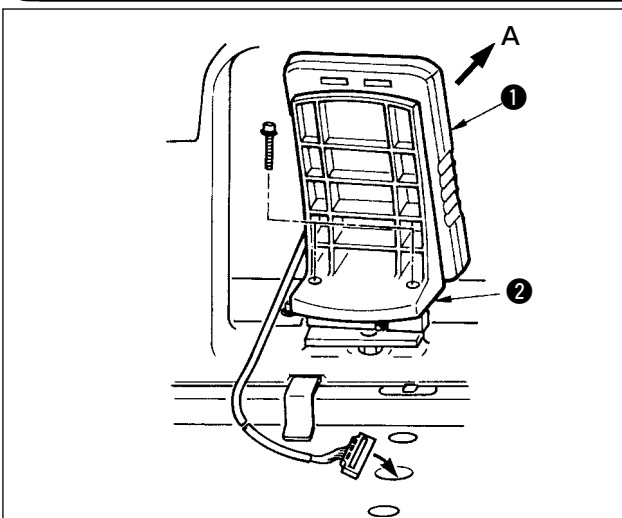

Fix panel installing plate ② to the base on the frame. Install operation panel ① with a magnet and pass the cable through the hole in the table.



When the panel is installed in the state that it is excessively tilted in the direction A, the work table comes in contact with the panel and the panel may be damaged. Install the panel so that it is not excessively tilted.

3-9 Connecting the cords

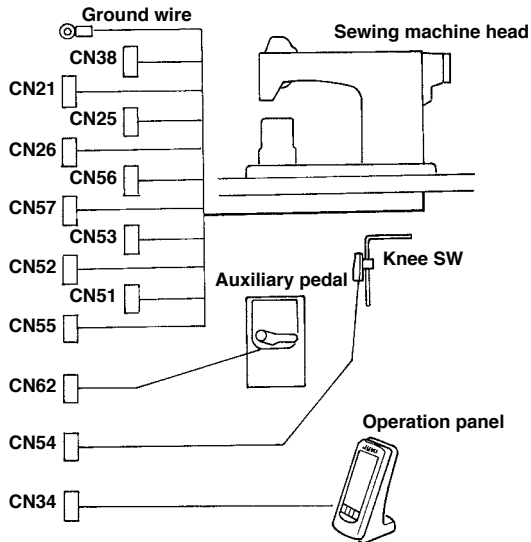

Terminal	No. of poles	Name of cable
CN38	White 4 poles	Power cable of main motor
CN21	White 9 poles	Encoder cable of main motor
CN25	Red 2 poles	Top feed fan cord
CN26	Red 2 poles	Bottom feed fan cord
CN56	White 10 poles	Feed motor cord
CN57	White 6 poles	Auxiliary feed motor cord
CN53	White 6 poles	Head relay cord 1
CN52	White 4 poles	Head relay cord 2
CN51	White 2 poles	Presser lifter cord
CN55	10 poles	DATA p.c.b. cord
CN62	Yellow 4 poles	
CN54	Red 4 poles	
CN34	26 poles	

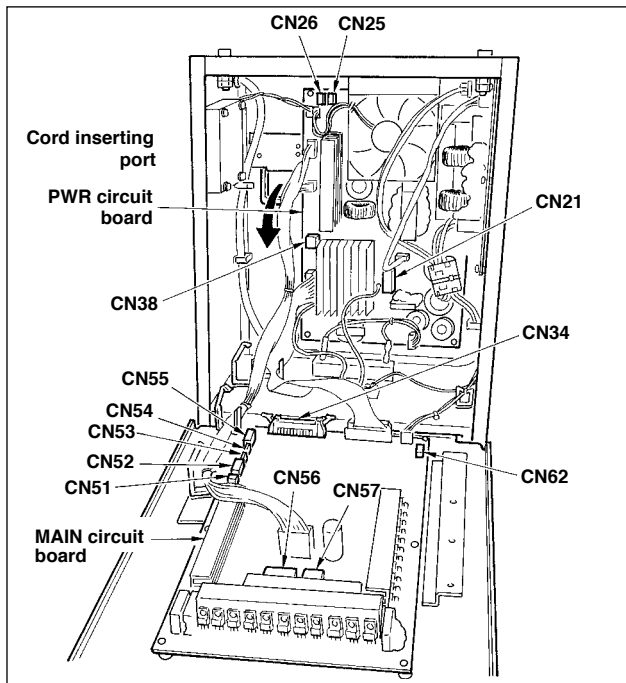

- 1) Remove the auxiliary pedal cord and insert the cord into the control box from the cord inserting port. Pass the auxiliary pedal cord through the rear side of the auxiliary pedal and insert it into the control box from hole **A** located on the lower side of the pedal sensor.
- 2) Fix the auxiliary pedal cord with the sticker (small) so that the cord does not move.
- 3) Connect CN38, 21, 25, and 26 to PWR p.c.b. CN 25 and 26 can be connected to either one. Conect others to MAIN p.c.b.

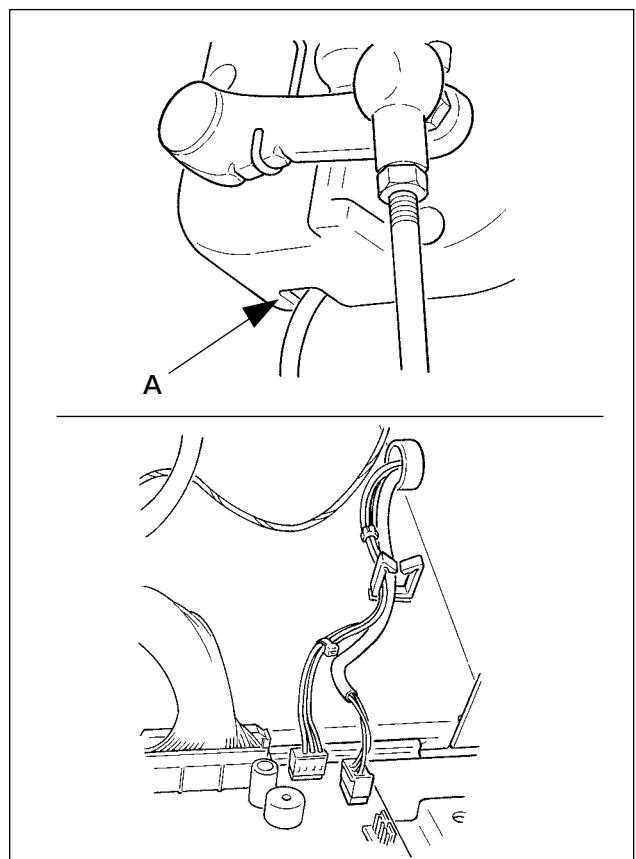
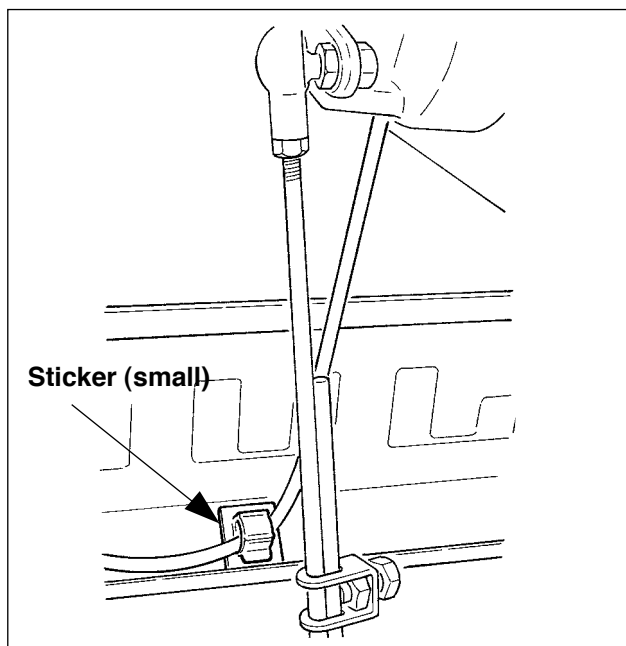

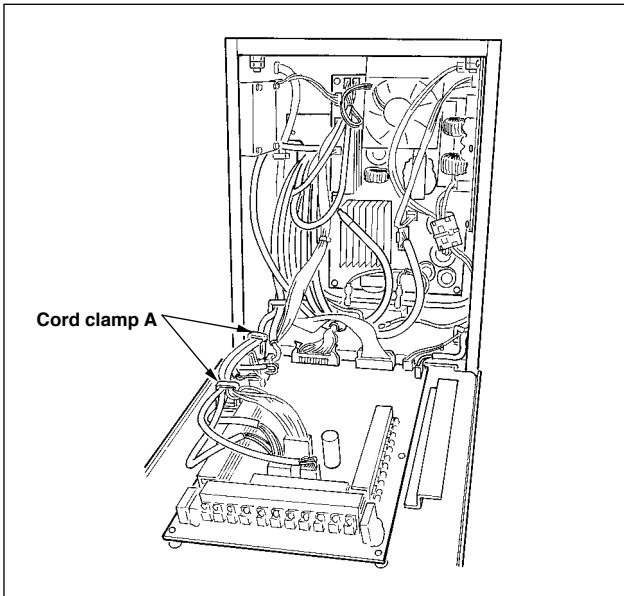

- 4) Fix the cords connected to MAIN p.c.b. with cord clamp A.

Handling the cords

- 1) When fixing the cords, connect them with the sewing machine tilted, and bundle with clip band ①.
- 2) When the machine head is returned to its home position, fix the cords with cord fixing plate ② in the state that there is the slack in the cords.

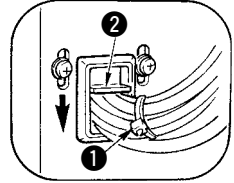

Caution : When tilting the sewing machine, make sure that the head support bar is attached to the table.

3-10 Installing the throat plate auxiliary plate

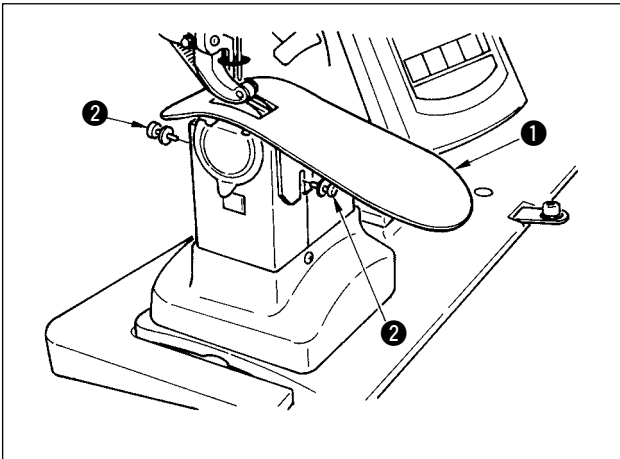

Loosen two screws ②, insert throat plate auxiliary plate ① and fix it.



Adjust the height so that the top surface of throat plate auxiliary plate aligns with that of the throat plate. If the height is not proper, material flops and the feed amount is not settled.

3-11 Installing the thread guide rod

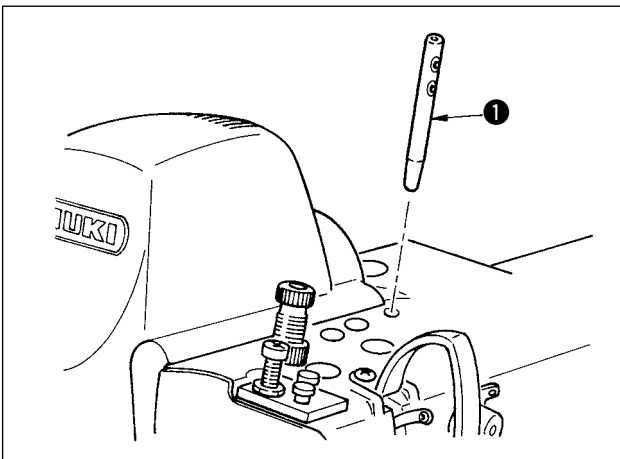

Securely insert thread guide rod ① so that two side holes of it faces the front in the direction of the operator.

3-12 Installing the thread stand

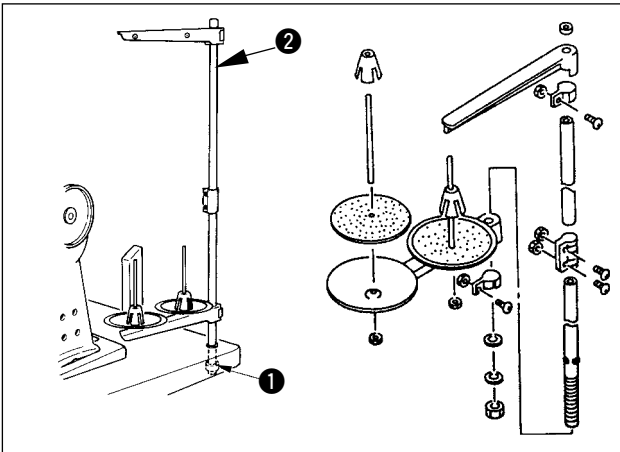

- 1) Assemble the thread stand unit and set it to the hole located on the upper right side of the table.
- 2) Tighten lock nut ① so that the thread stand unit does not move.
- 3) When ceiling wiring is possible, pass the power cable through the inside of thread stand rod ②.

3-13 Assembling the table for work (WORK TOP TABLE)

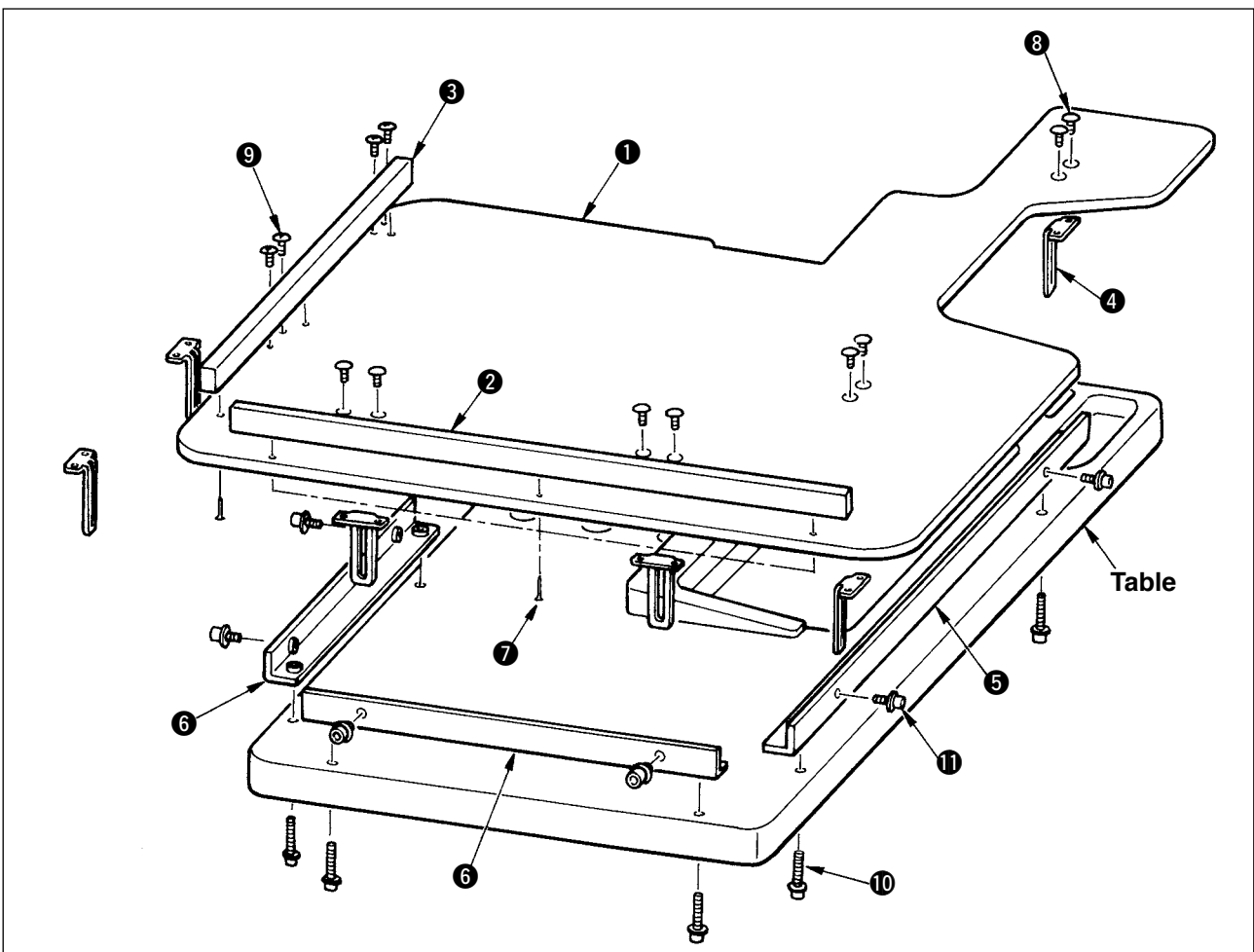

- 1) Install edge guide A ② and B ③ on table for work ① with 3 pcs. each of wood screw ⑦.
- 2) Temporarily tighten base A ⑤ and base B ⑥ on the table with screws ⑩.
- 3) Temporarily tighten adjusting plate ④ with 8 screws ⑧ and 4 screws ⑨.
- 4) Place table for work ① on the base and temporarily tighten it with screw ⑪.
- 5) Tighten screws ⑧, ⑨ and ⑩ while checking the whole position.
- 6) Loosen screw ⑪ and tighten it in accordance with the height you desire.



There are the standard size and the long one for the adjusting plate.

When you desire to make the table for work higher, replace the standard size plate with the long size one.

4. PREPARATION BEFORE OPERATION

4-1 Attaching the needle



WARNING :

Turn OFF the power before starting the work so as to prevent accidents caused by abrupt start of the sewing machine.

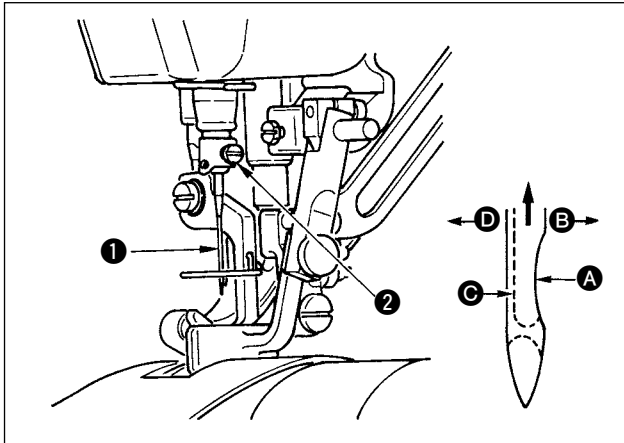

- 1) Turn the handwheel until the needle bar reaches the highest point of its stroke.
- 2) Loosen screw ②, and hold needle ① with its indented part ① facing exactly to the right in direction ③.
- 3) Insert the needle fully into the hole in the needle bar in the direction of the arrow until the end of hole is reached.
- 4) Securely tighten screw ②.
- 5) Check that long groove ④ of the needle is facing exactly to the left in direction ④.

4-2 Threading the needle-thread



WARNING :

Turn OFF the power before starting the work so as to prevent accidents caused by abrupt start of the sewing machine.

* Pass thread in the order of ① through ⑬ as shown in the illustration.

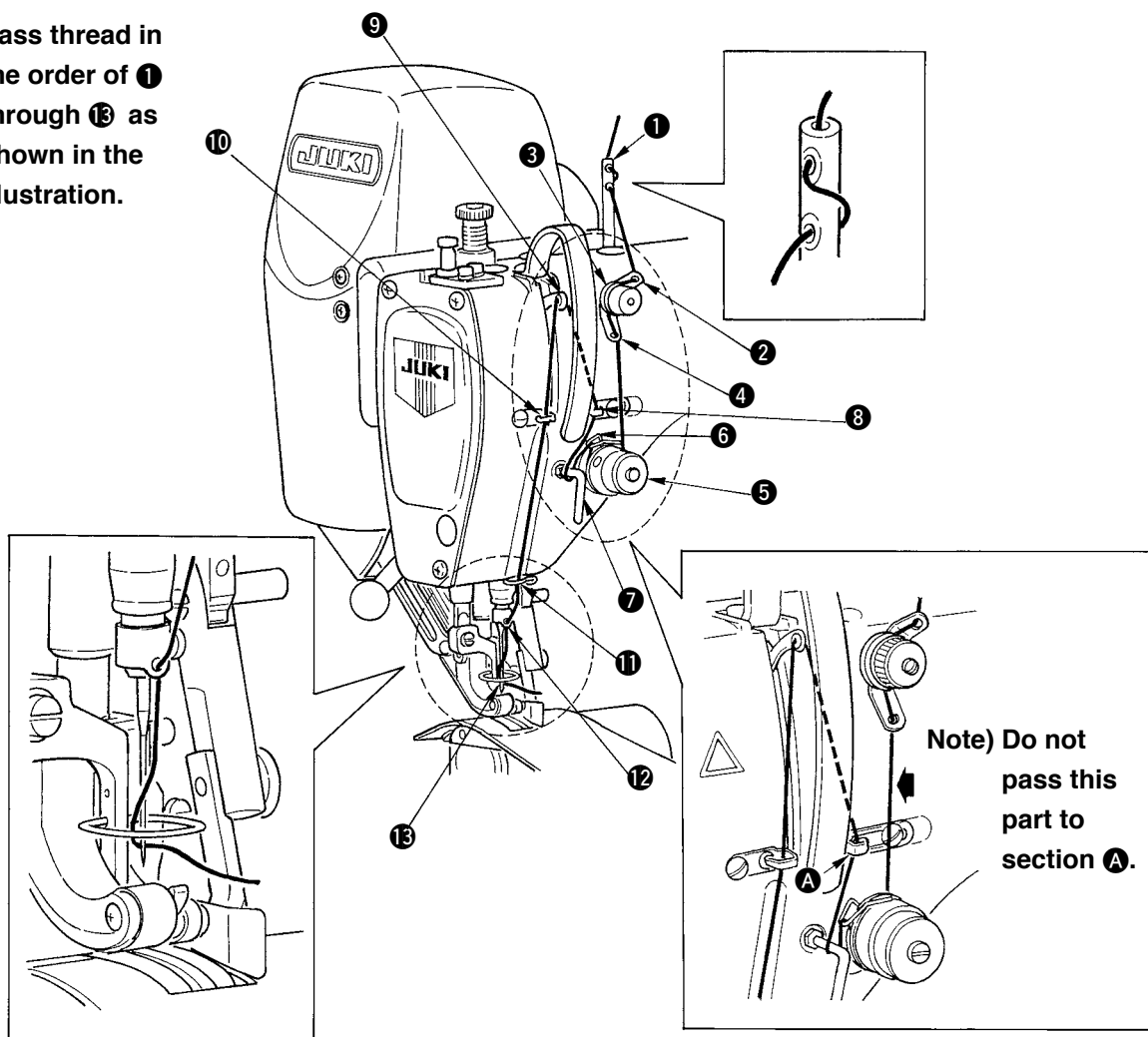

4-3 Winding the bobbin thread

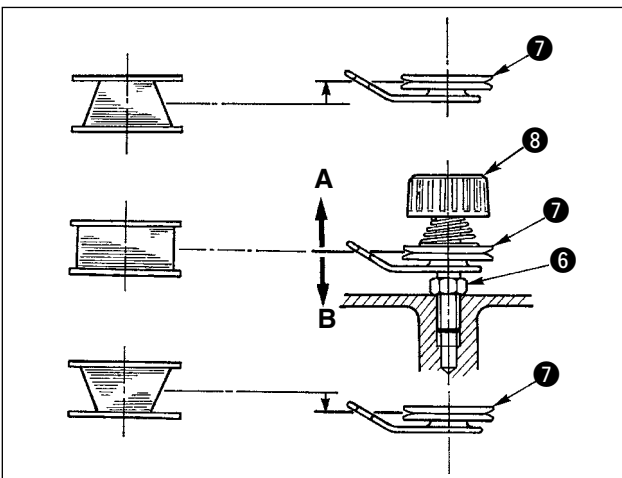
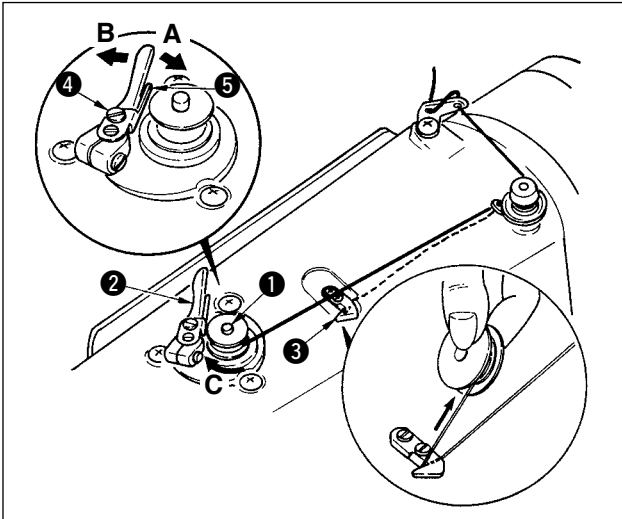

- 1) Insert the bobbin deep into the bobbin winder spindle ① until it will go no further.
- 2) Pass the bobbin thread pulled out from the spool rested on the right side of the thread stand following the order as shown in the figure on the left. Then, wind clockwise the end of the bobbin thread on the bobbin several times.
(In case of the aluminum bobbin, after winding clockwise the end of the bobbin thread, wind counterclockwise the thread coming from the bobbin thread tension several times to wind the bobbin thread with ease.)
- 3) Press the bobbin winder trip latch ② in the direction of A and start the sewing machine. The bobbin rotates in the direction of C and the bobbin thread is wound up. The bobbin winder spindle ① automatically as soon as the winding is finished.
- 4) Remove the bobbin and cut the bobbin thread with the thread cut retainer ③.
- 5) To adjust the winding amount of the bobbin thread, loosen the setscrew ④ and move the bobbin winder adjusting plate ⑤ to the direction of A or B. Then, tighten the setscrew ④.
To the direction of A : Decrease
To the direction of B : Increase
- 6) In case that the bobbin thread is not wound evenly on the bobbin, loosen the nut ⑥ and turn the bobbin thread tension to adjust the height of the thread tension disk ⑦.
• It is the standard that the center of the bobbin is as high as the center of the thread tension disk.

• Move the position of the thread tension disk ⑦ to the direction of A as shown in the figure on the left when the winding amount of the bobbin thread on the lower part of the bobbin is excessive and to the direction of B as shown in the figure on the left when the winding amount of the bobbin thread on the upper part of the bobbin is excessive.

After the adjustment, tighten the nut ⑥.

- 7) To adjust the tension of the bobbin winder, turn the thread tension nut ⑧.

- (Caution)**
1. When winding the bobbin thread, start the winding in the state that the thread between the bobbin and thread tension disk ⑦ is tense.
 2. When winding the bobbin thread in the state that sewing is not performed, remove the needle thread from the thread path of thread take-up and remove the bobbin from the hook.
 3. There is the possibility that the thread pulled out from the thread stand is loosened due to the influence (direction) of the wind and may be entangled in the handwheel. Be careful of the direction of the wind.

4-4 Setting the bobbin into the bobbin case

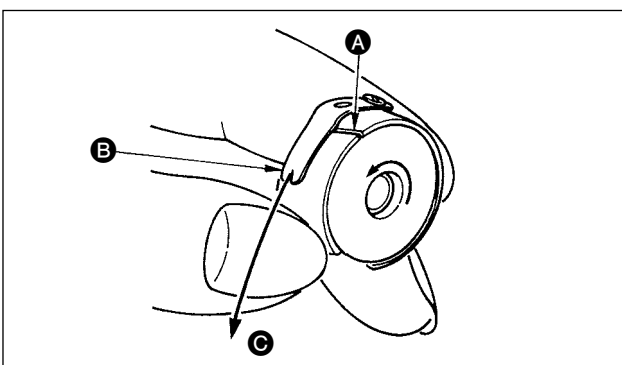

- 1) Install the bobbin in the bobbin case so that the thread wound direction is clockwise.
- 2) Pass the thread through thread slit A, and pull the thread in direction B. By so doing, the thread will pass under the tension spring and come out from notch B.
- 3) Check that the bobbin rotates in the direction of the arrow when thread C is pulled.

4-5 Attaching and removing the bobbin case

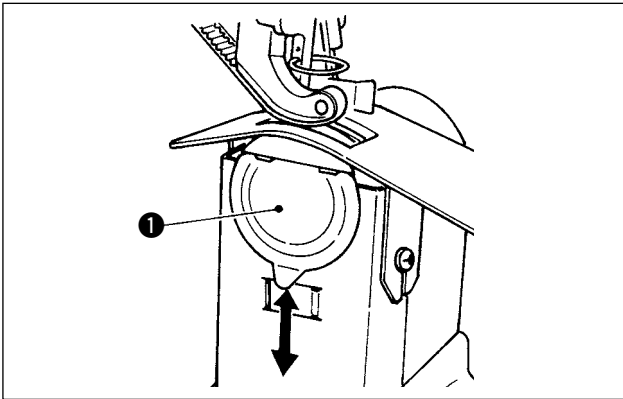

For attaching and removing the bobbin case, slide cover ① up or down to perform it.



1. When attaching the bobbin case, insert it until it will go no further. If it is insufficient, the bobbin case may fall off during sewing.
2. Be sure to close the cover when starting the sewing machine. There is a danger of rolling cloth in the bobbin case or the like.

4-6 Adjusting the thread tension

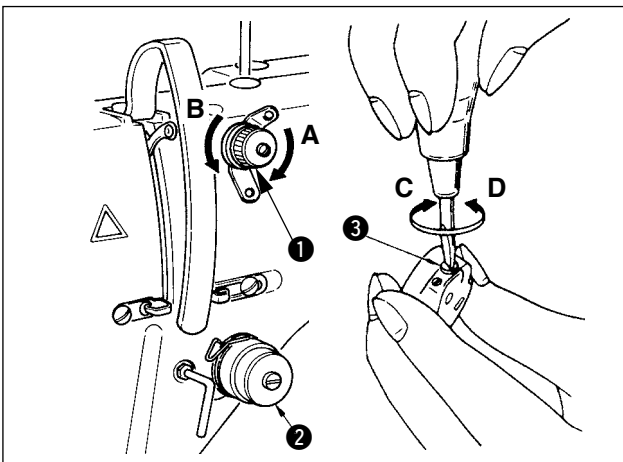

[Adjusting the needle thread tension]

- 1) Turn clockwise (direction A) thread tension nut No. 1 ① and the length of thread remaining at the needle tip after thread trimming will be shortened.
- 2) Turn it counterclockwise (direction B) and the length of thread will be lengthened.
- 3) Thread tension of thread tension No. 2 ② is set with the operation panel.

For the details, refer to "[5-6 \(3\) Changing the needle thread tension](#)".

[Adjusting the bobbin thread tension]

- 1) Turn clockwise (direction C) thread tension screw ③ and the bobbin thread tension is increased.
- 2) Turn it counterclockwise (direction D) and the tension is decreased.

4-7 Adjusting the thread take-up spring

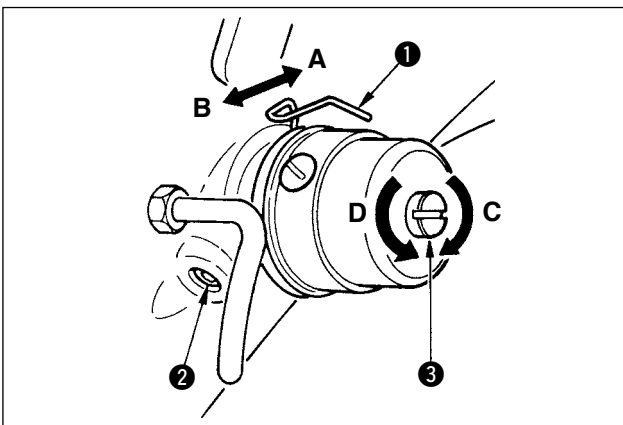

[Changing the stroke amount of thread take-up spring ①]

- 1) Loosen setscrew ② in the thread tension base.
- 2) Turn clockwise (direction A) the whole thread tension and the stroke amount is increased.
- 3) Turn it counterclockwise (direction B) and the stroke amount is decreased.

[When changing the pressure of thread take-up spring ①]

- 1) Put a thin screwdriver in the slot of thread tension rod ③ and turn it with screw ② tightened.
- 2) Turn clockwise (direction C) the thread tension rod and the pressure is increased and turn it counterclockwise (direction D) and the pressure is decreased.

4-8 Adjusting the stitch guide

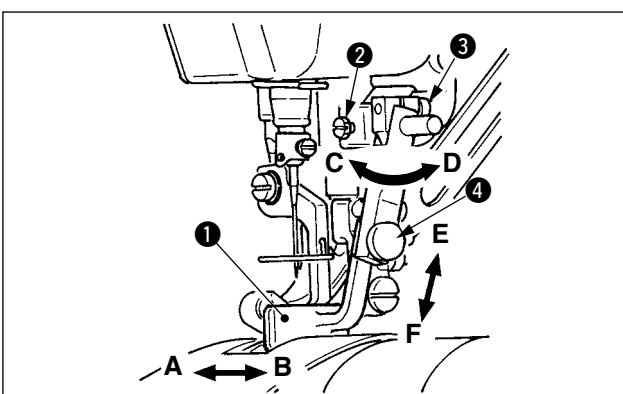







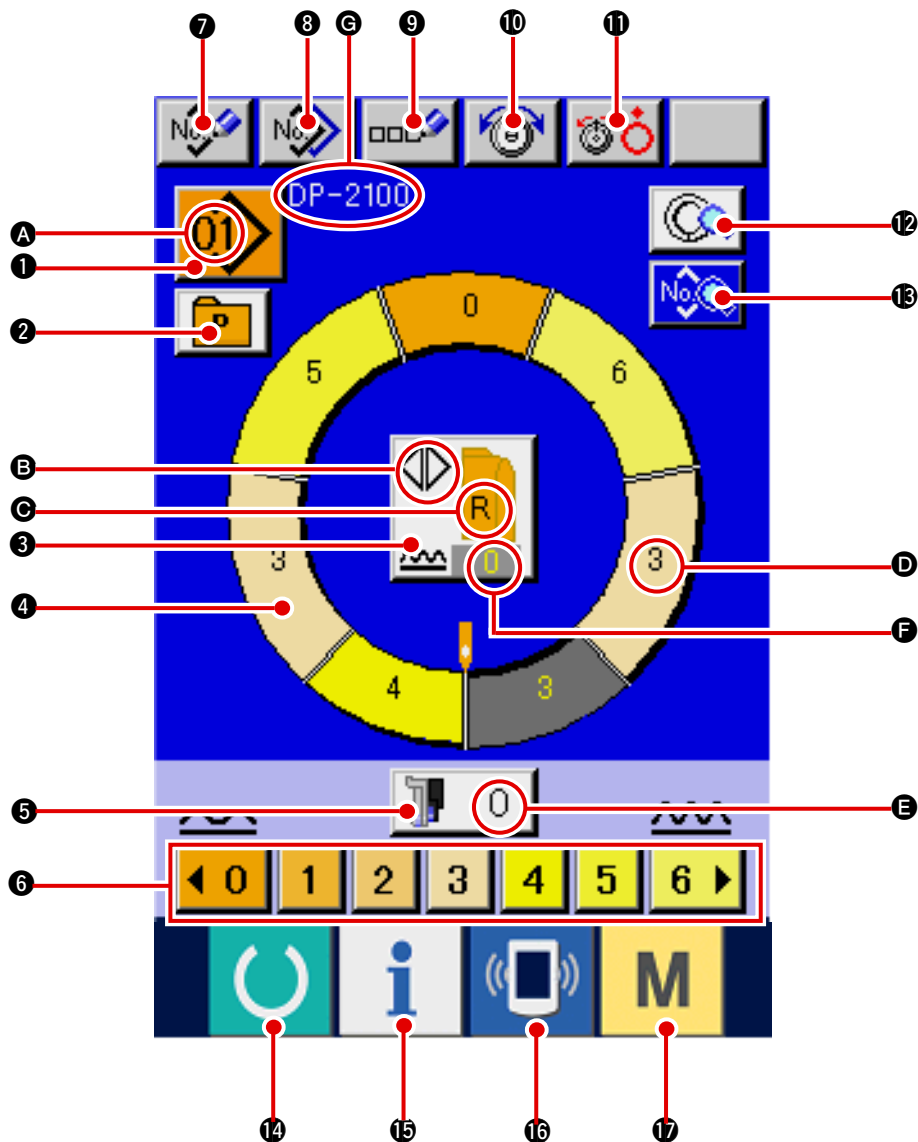



- 1) When setscrew ② is loosened, fine adjustment A - B direction of stitch guide ① position can be performed. After the adjustment, securely tighten setscrew ②.
- 2) When setscrew ③ is loosened, fine adjustment A - B and C - D direction of stitch guide ① position can be performed. After the adjustment, securely tighten setscrew ③.
- 3) When setscrew ④ is loosened, fine adjustment E - F direction of stitch guide ① position can be performed. After the adjustment, securely tighten setscrew ④.







5. OPERATION OF THE SEWING MACHINE (SEMI-AUTOMATIC BASIC VOLUME)

5-1 Data input screen



No.	Button	Name of button	Description
①		PATTERN SELECTION button	Pattern No. being selected at present is displayed on the button and when the button is pressed, PATTERN No. CHANGE screen is displayed.
②		DIRECT SELECTION button	When the button is pressed, the list screen of pattern Nos. which are registered in DIRECT SELECTION button is displayed.
③		LEFT/RIGHT/ALTERNATE SEWING SELECTION button	Changeover method of program (for right sleeve and left sleeve) during sewing is selected.
④		STEP SELECTION button	When the button is pressed, the step becomes in the state of selection.
⑤		SHIRRING AMOUNT FOR AUXILIARY FEED button	When the button is pressed, shirring amount for auxiliary feed change screen is displayed.
⑥		SHIRRING AMOUNT button	When the button is pressed, shirring amount of the step being selected is changed.

No.	Button	Name of button	Discription
7		PATTERN NEW REGISTER button	When the button is pressed, pattern No. new register screen is displayed.
8		PATTERN COPY button	When the button is pressed, sewing data copy screen is displayed.
9		LETTER INPUT button	When the button is pressed, letter input screen is displayed.
10		NEEDLE THREAD TENSION SETTING button	When the button is pressed, needle thread tension change screen is displayed.
11		DISK RISE button	When the button is pressed, thread tension disk No. 1 rises. (Turn OFF the base tension during UIT waiting.)
12		STEP DETAILS button	When the button is pressed, list of sewing data corresponding to the step being selected is displayed.
13		SEWING DATA DISPLAY button	List of sewing data corresponding to the pattern No. being selected is displayed.
14		READY key	Changeover of data input screen and sewing screen is performed.
15		INFORMATION key	Changeover of data input screen and information screen is performed.
16		COMMUNICATION key	Changeover of data input screen and communication screen is performed.
17		MODE key	Changeover of data input screen and mode changeover screen to perform various details setting is performed.

Symbol	Display	Name of display	Description
A		PATTERN No. display	Pattern No. is displayed.
B		ALTERNATE SEWING display	This is displayed when alternate sewing is selected.
C		LEFT/RIGHT SLEEVE display	R display : Program for right sleeve is called. L display : Program for left sleeve is called.
D		SHIRRING AMOUNT display	Shirring amount is displayed.
E		SHIRRING AMOUNT FOR AUXILIARY FEED display	Shirring amount of auxiliary feed is displayed.
F		SHIRRING AMOUNT INCREASE/DECREASE SET VALUE display	Shirring amount increase/decrease set value is displayed.
G		PATTERN NAME display	Pattern name is displayed.

5-2 Sewing screen

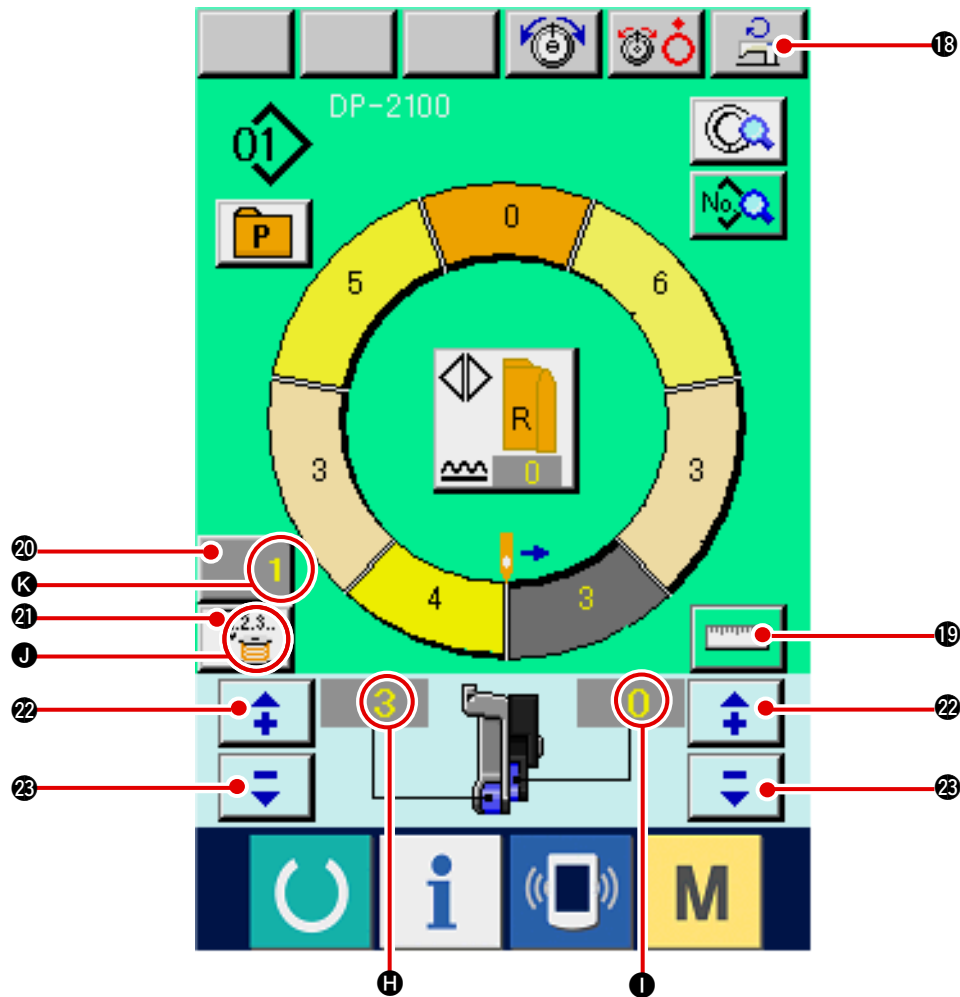

No.	Button	Name of button	Description
18		Max. SEWING SPEED SETTING button	When the button is pressed, max. sewing speed setting screen is displayed.
19		MEASURE button	When the button is pressed, length of each step is measured during sewing and is reflected to icon display shape of step selection button.
20		COUNTER SETTING button	When the button is pressed, bobbin/No. of pcs. counter setting screen is displayed.
21		COUNTER SELECTION button	When the button is pressed, bobbin/No. of pcs. counter is changed over.
22		+ button	When the button is pressed, the numeral is increased.
23		- button	When the button is pressed, the numeral is decreased.

Symbol	Display	Name of display	Description
H		SHIRRING AMOUNT display	Shirring amount is displayed.
I		SHIRRING AMOUNT FOR COUNTER display	Shirring amount of auxiliary feed is displayed.
J		AUXILIARY FEED display	display : This is displayed when bobbin counter is used. display : This is displayed when No. of pcs. counter is used.
K		COUNTER SET VALUE display	Counter set value is displayed.

5-3 Details data input screen

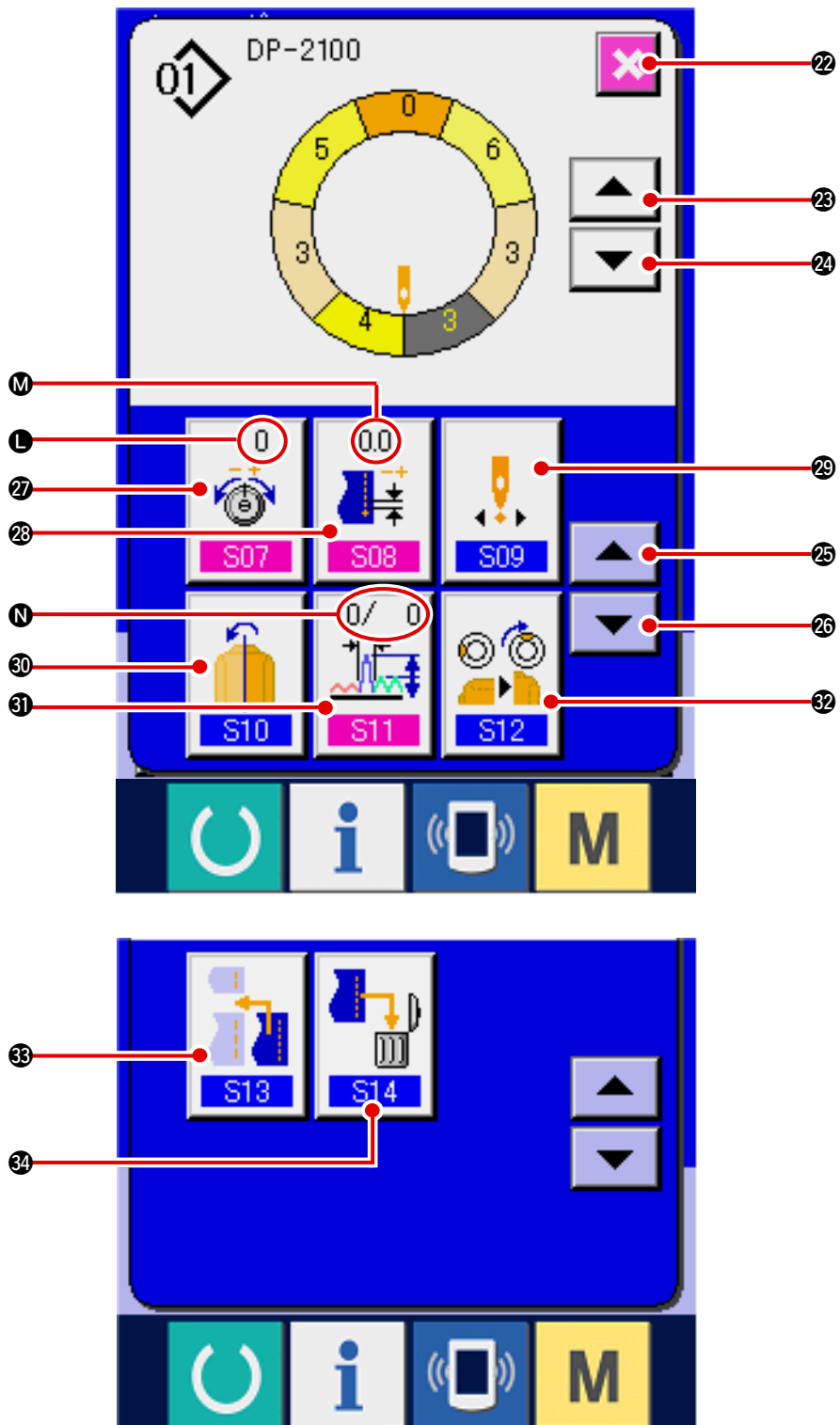

No.	Button	Name of button	Description
22		CANCEL button	When the button is pressed, the step details button is closed.
23		STEP FEED button	When the button is pressed, the selected step advances by one.
24		STEP RETURN button	When the button is pressed, the selected step returns by one.
25		DETAILS SELECTION SCREEN FEED button	When the button is pressed, the details selection screen scrolls forward.
26		DETAILS SELECTION SCREEN RETURN button	When the button is pressed, the details selection screen scrolls backward
27		COMPENSATION THREAD TENSION SETTING button	When the button is pressed, pattern deletion screen is displayed.
28		COMPENSATION PITCH SETTING button	When the button is pressed, compensation thread tension setting screen is displayed.
29		START POSITION CHANGE button	When the button is pressed, mirroring screen is displayed.
30		MIRRORING button AMOUNT	When the button is pressed, mirroring screen is displayed.
31		COMPENSATION SHIRRING AMOUNT button	When the button is pressed, compensation shirring amount setting screen is displayed.
32		TOP NOTCH POSITION CHANGE button	When the button is pressed, top notch position change screen is displayed.
33		STEP ADDITION button	When the button is pressed, step addition setting screen is displayed.
34		STEP DELETION button	When the button is pressed, step deletion screen is displayed.

Symbol	Display	Name of display	Description
L		COMPENSATION THREAD TENSION display	Set value of compensation thread tension is displayed.
M		COMPENSATION PITCH display	Set value of compensation pitch is displayed.
N		COMPENSATION AMOUNT display	Set value of compensation shirring amount is displayed.

5-4 Feed amount

The explanation is given for the feed amount of the sewing machine.

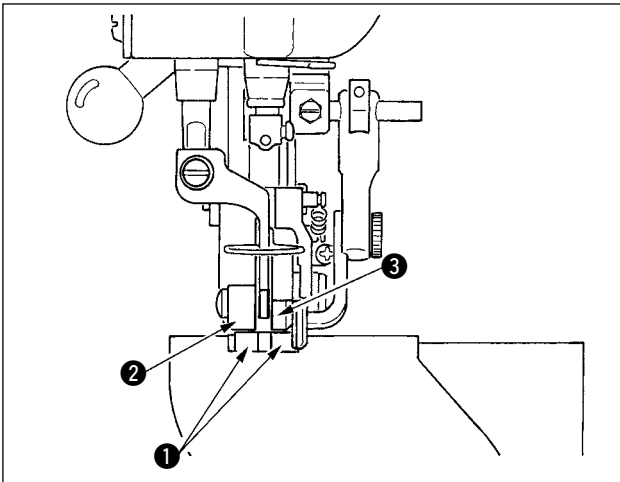

Feed amount on the operation consists of the three kinds of feed amounts, bottom feed amount (pitch), main feed amount (pitch + shirring amount) and auxiliary feed amount (pitch + shirring amount + shirring amount for auxiliary feed).

In case of **A**, when pitch (S04) is set to 2.0, bottom feed belt ① moves 2.0 mm per rotation of the sewing machine (1 stitch).

In case of **B**, when shirring amount is set to 3, main feed belt ② moves 2.3 mm per rotation of the sewing machine (1 stitch).

This means that set value "1" of shirring amount (main feed) is in steps of 0.1 mm and when the set value is converted to mm, $3 \times 0.1 = 0.3$ mm is calculated. This value is added to pitch (bottom feed) and the total value becomes the moving amount of the main feed belt.

$$\begin{aligned} \text{Main feed amount} &= \text{pitch} + \text{shirring amount} \\ 2.3 \text{ mm} &= 2.0 \text{ mm} + 0.3 \text{ mm} \end{aligned}$$

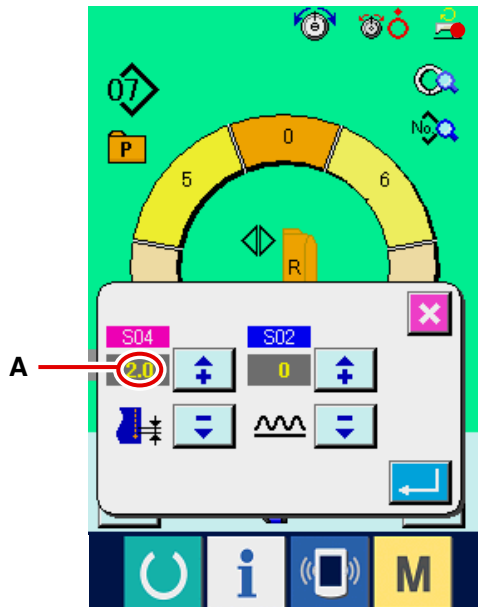

Pitch setting screen

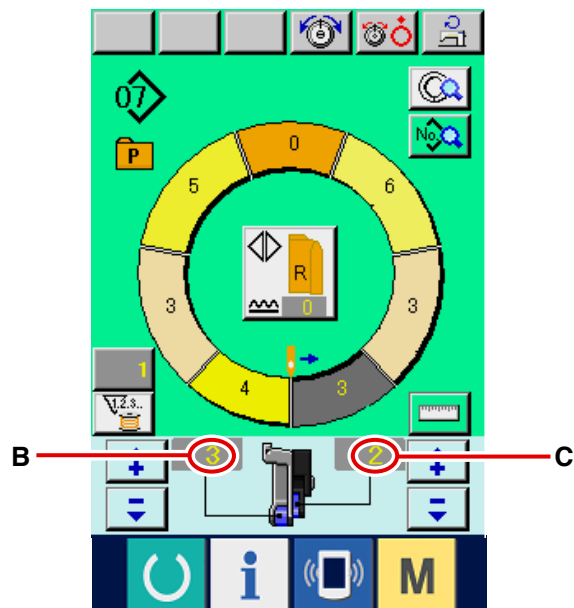

Sewing screen

In case of **C**, when shirring amount for auxiliary feed is set to 2, auxiliary feed belt ③ moves 2.5 mm per rotation of the sewing machine (1 stitch).

This means that set value "1" of shirring amount for auxiliary feed (auxiliary feed) is in steps of 0.1 mm and when the set value is converted to mm, $2 \times 0.1 = 0.2$ mm is calculated. This value is added to the main feed amount and the total value becomes the moving amount of the auxiliary belt.

$$\begin{aligned} \text{Auxiliary feed amount} &= \text{main feed amount} + \\ &\quad \text{shirring amount for} \\ &\quad \text{auxiliary feed} \\ 2.5 \text{ mm} &= 2.3 \text{ mm} + 0.2 \text{ mm} \end{aligned}$$

5-5 Basic operation of the sewing machine

(1) Prepare the materials.

Prepare right and left sleeves and garment body.

(2) Turn ON the power.

1) Turn ON the power switch.

2) Data input screen is displayed after the display of the initial screen.



Auto-lifter does not work until the screen moves to the sewing screen or the new creation screen. After it has worked, it works in all screens. So, be careful.

(3) Calling the pattern <Pattern No. selection>

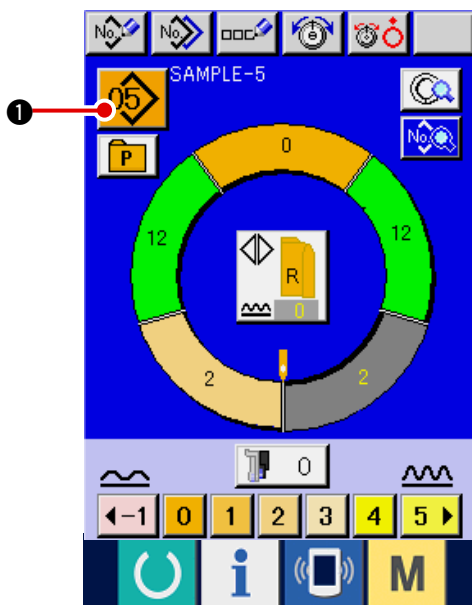

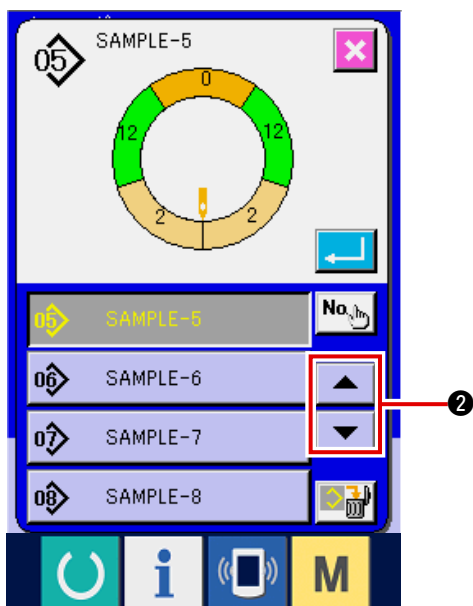

Two programs (for right sleeve and left sleeve) are entered in one pattern. Further, the respective programs consist of single or plural steps (sewing data between the respective notches are stored).

1) Press PATTERN SELECTION button  ①.



2) Press UP/DOWN SCROLL buttons 

 ② to display pattern No. button

 of the pattern you desire to call.

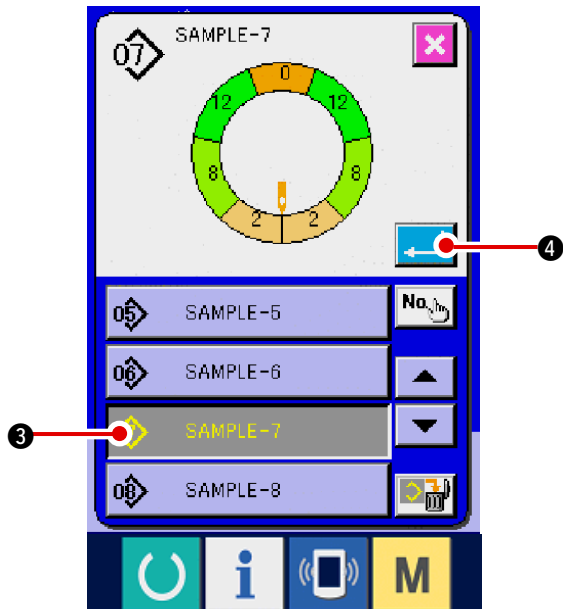

3) Press pattern No. button  ③.

4) Press ENTER button  ④.

(4) Select left/right alternate sewing. <Left/right alternate sewing selection>

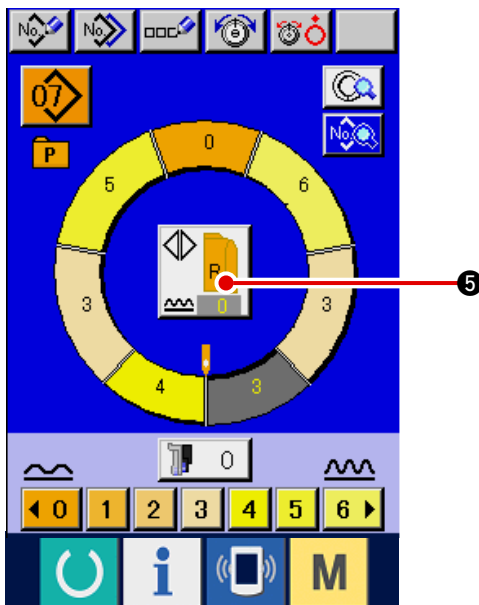



Press LEFT/RIGHT ALTERNATE SEWING button

 ⑤ to select the program changeover method (for right sleeve and left sleeve).

 Alternate sewing, right : Left/right alternate sewing starting from the right sleeve

 Alternate sewing, left : Left/right alternate sewing starting from the left sleeve

 Right sleeve only : Right sleeve sewing only

 Left sleeve only : Left sleeve sewing only

(5) Perform sewing.

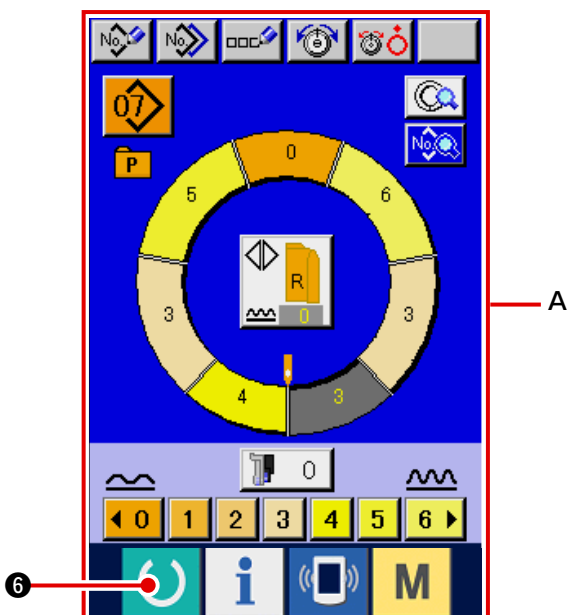

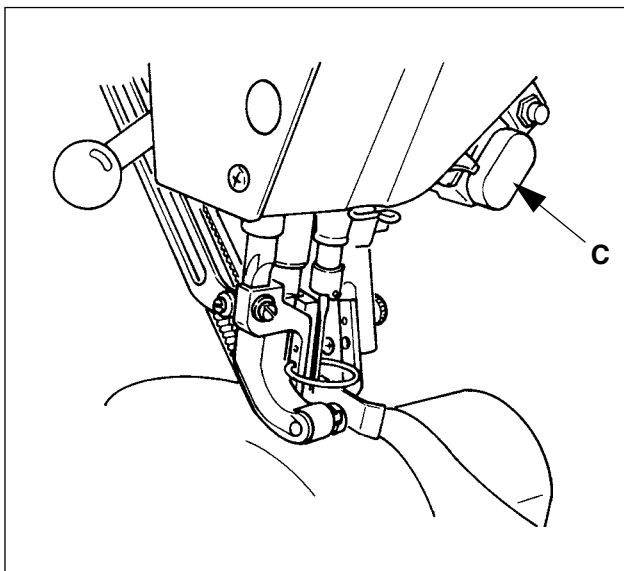
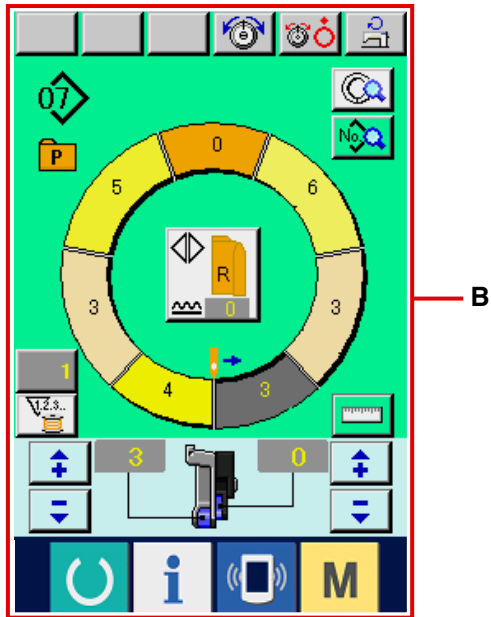

1) Press READY key  ⑥.

2) Display is changed over from data input screen **A** to sewing screen **B**.

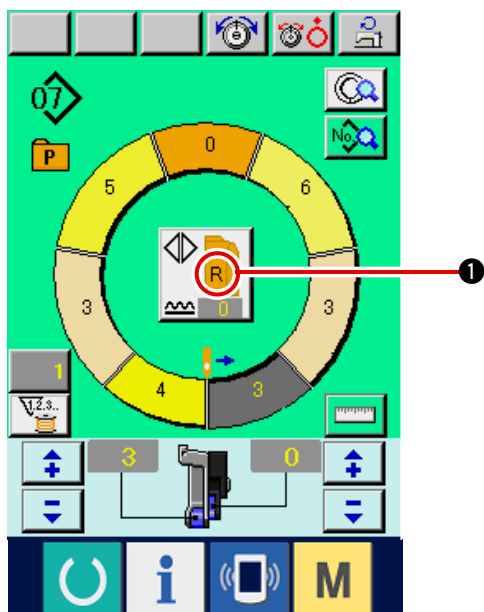

- 3) Set sleeves and garment body to the sewing machine.
- * When temporarily setting the shirring amount to "0" during sewing, press SHIRRING RELEASE switch **C**.
When the switch is pressed, LED lights up and the shirring amount is set to "0". When the switch is pressed twice, LED goes off and the shirring amount returns to the shirring amount of the selected step.



- 4) Check LEFT/RIGHT ALTERNATE SEWING button  **1** whether or not the set materials correspond with the called program (for right sleeve/left sleeve).
- 5) Start sewing.
- 6) When sewing is performed up to the next notch, stop the sewing machine once.

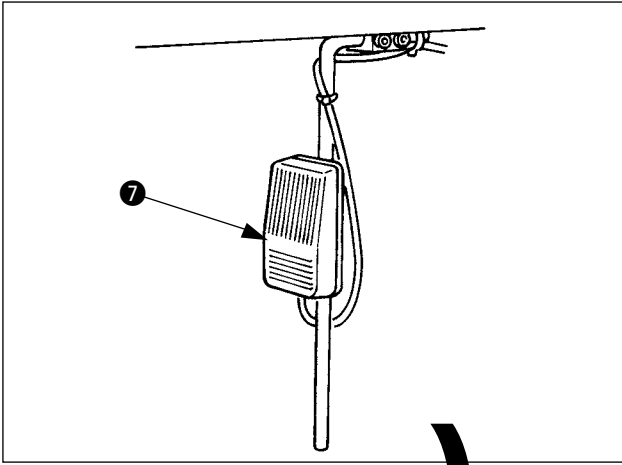

7) Press once knee switch **7**. Step of the program advances by one (A).

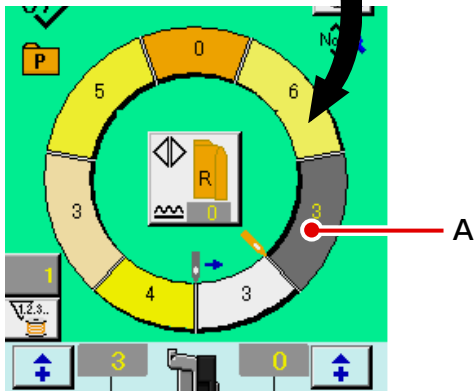

8) Repeat procedure 5) through 7) until the end of sewing.

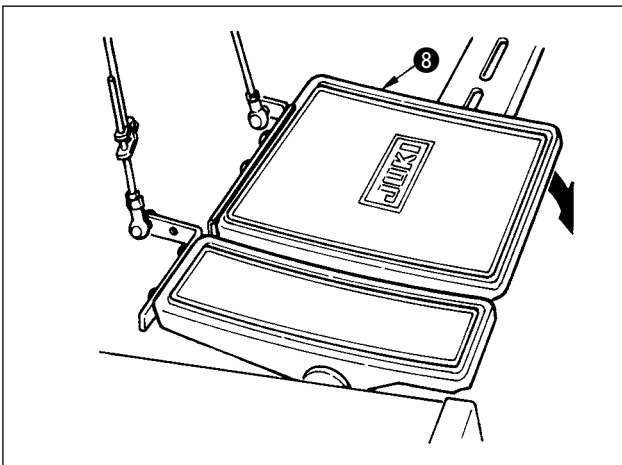

9) Perform thread trimming with pedal **8**.

5-6 Basic change of the set value

(1) Changing the sewing speed <Max. sewing speed setting>

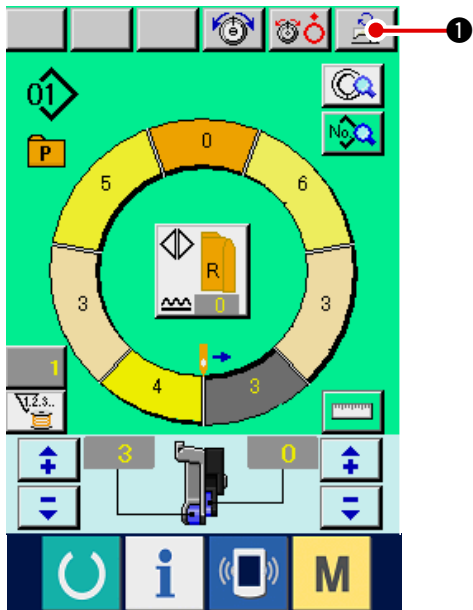

1) Press MAX. SEWING SPEED SETTING button



1 in the sewing screen.

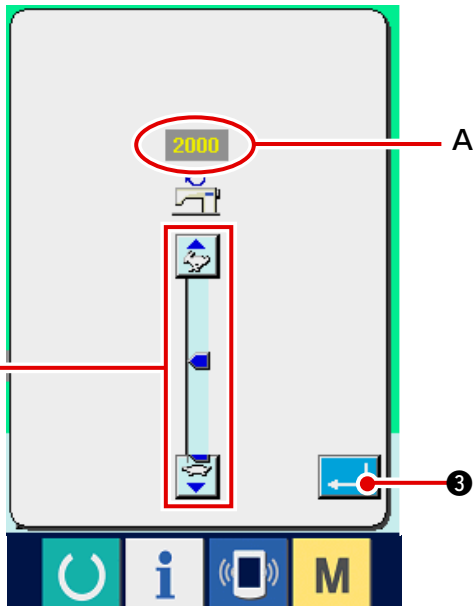

2) Press MAX. SEWING SPEED CHANGE button



(fast) and (slow) 2 alternately to

change "speed set value" A .

3) Press ENTER button



3.

(2) Changing the pitch <Pitch setting>

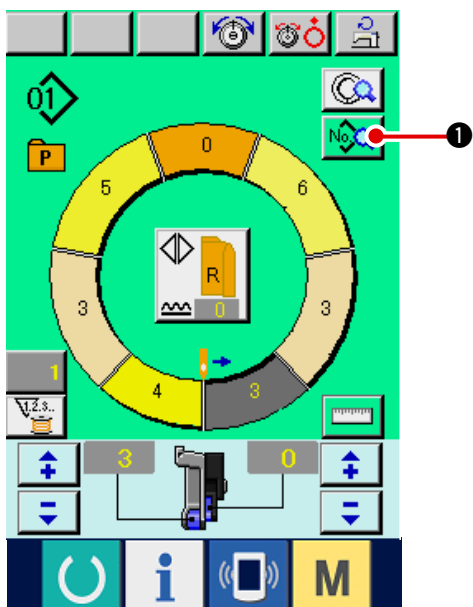



1) Press SEWING DATA DISPLAY button

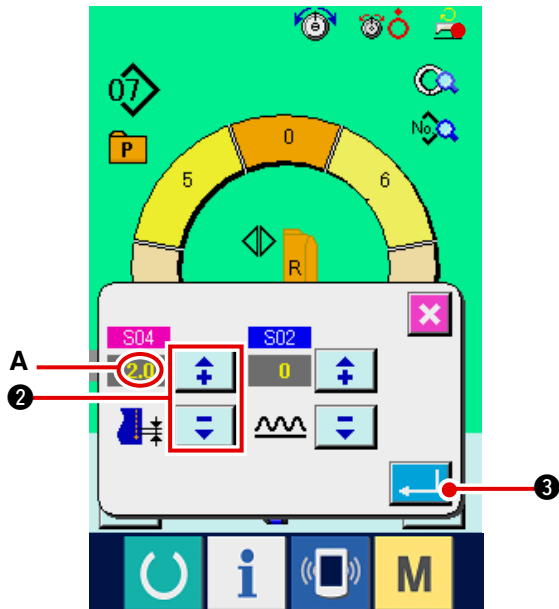

1.



- 2) Press "+"/ "-" buttons   ② to change "sewing pitch" A.
- 3) Press ENTER button  ③.

(3) Changing the needle thread tension <Needle thread tension setting>

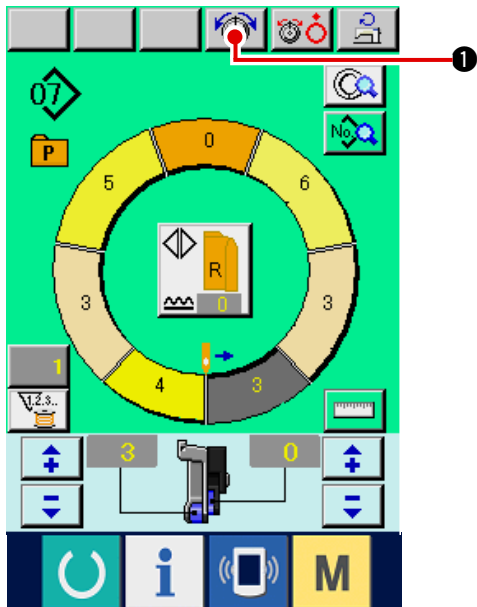

- 1) Press NEEDLE THREAD TENSION SETTING button  ①.

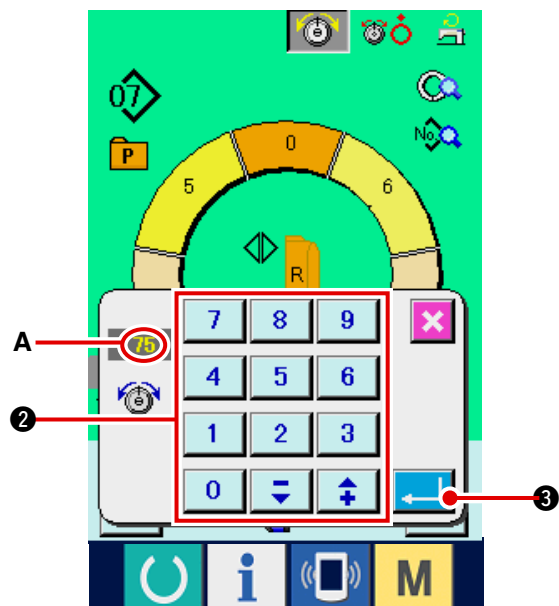

- 2) Press ten keys

7	8	9
4	5	6
1	2	3
0	↓	↑

 ② to change needle thread tension set value A.
- 3) Press ENTER button  ③.

(4) Changing the shirring amount <Shirring amount setting>

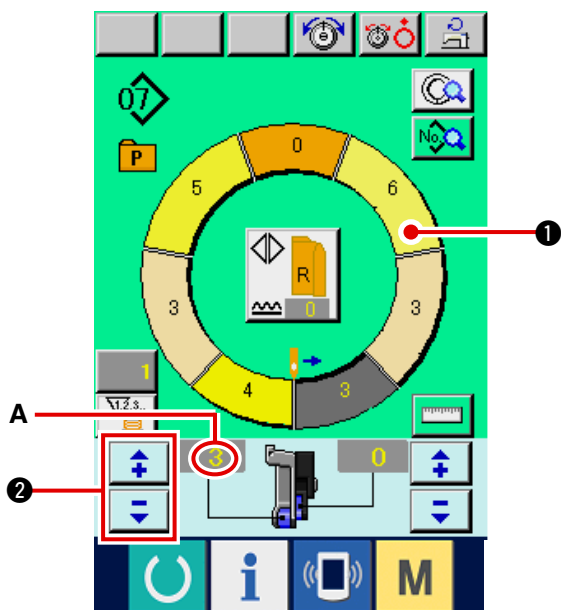

1) Press STEP SELECTION button

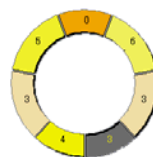

1 to select step.

2) Press "+"/ "-" buttons  2 to change shirring amount set value A.

(5) Changing the shirring amount of auxiliary feed <Auxiliary feed shirring amount setting>

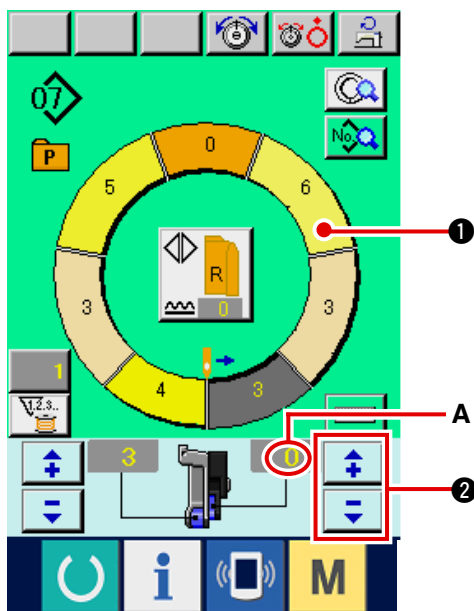

1) Press STEP SELECTION button

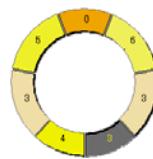

1 to select step.

2) Press "+"/ "-" buttons  2 to change shirring amount set value for auxiliary feed A.

5-7 Creating the pattern <Pattern creation>



The way of correcting the sample pattern and creating the pattern with ease is explained in the basic volume.

- 1) Prepare the materials.
- 2) Turn ON the power.

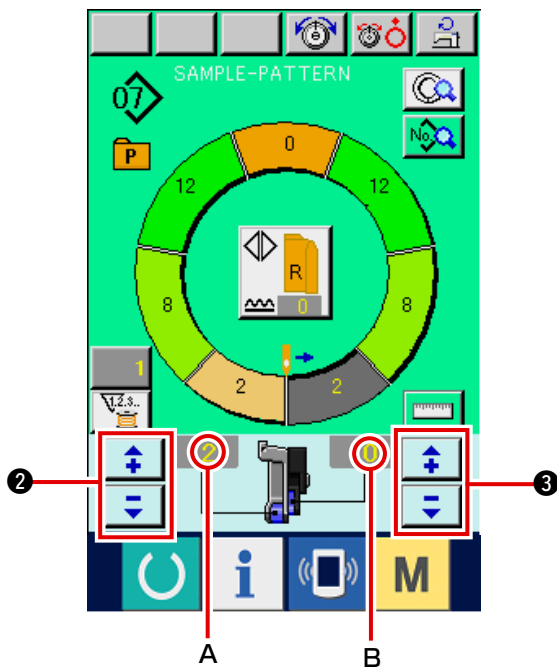

- 3) Call a sample pattern where the sewing products and number of steps are the same.
Refer to ["5-5 \(3\) Calling the pattern"](#).
- 4) Change the pitch.
Refer to ["5-6 \(2\) Changing the pitch"](#).
- 5) Select left/right alternate sewing.
Refer to ["5-5 \(4\) Select left/right alternate sewing"](#).
- 6) Press READY key  ①.
- 7) Perform sewing.
- 8) Stop the sewing machine at each notch and perform checking of shirring amount.





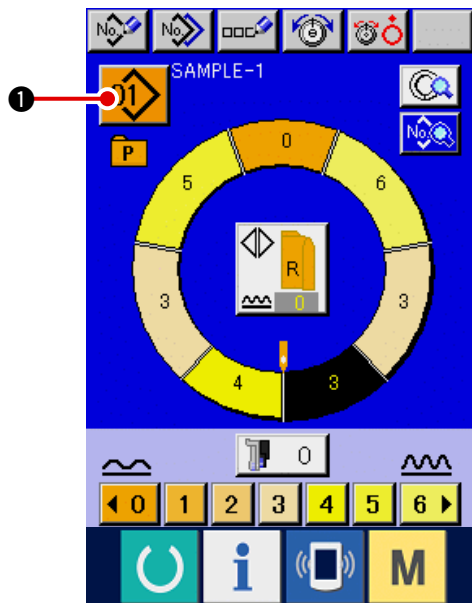

- 9) When notches do not fit properly, press "+"/ "-" buttons  ② after thread trimming on the way to change shirring amount set value **A**. Then perform re-sewing.
Refer to ["5-6 \(4\) Changing the shirring amount"](#).
- 10) When the sleeve material on the outlet seam side delays, press "+"/ "-" buttons  ③ after thread trimming on the way to change set value of shirring amount for auxiliary feed **B**. Then perform re-sewing.
Refer to ["5-6 \(5\) Changing the shirring amount of auxiliary feed"](#).
- 11) When the program for one sleeve is completed, sew the other sleeve and correct the program.

5-8 Deleting the pattern <Pattern deletion>

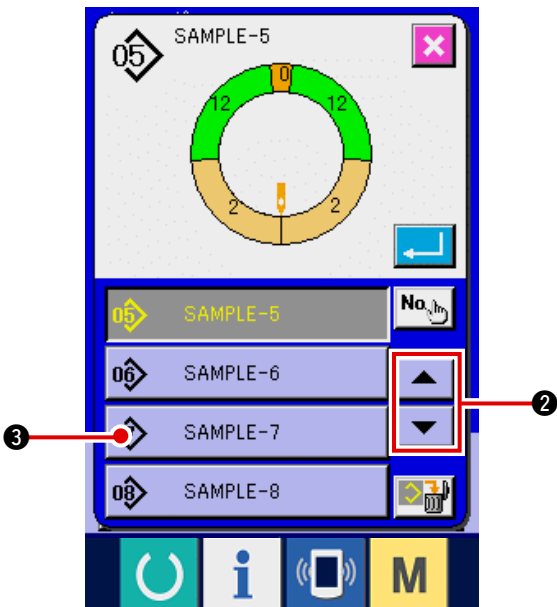

1) Press PATTERN SELECTION button  ①.



2) Press UP/DOWN SCROLL buttons   ② to display pattern No. button  SAMPLE-7 ③ of the pattern to be deleted.

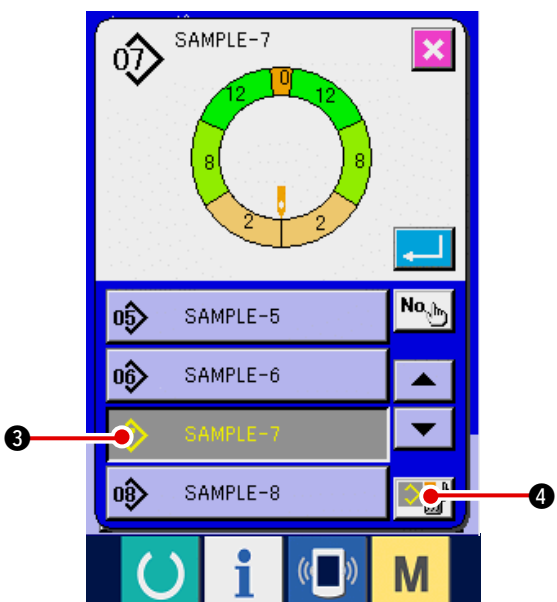



3) Press PATTERN No. button  SAMPLE-7 ③.

4) Press PATTERN DELETION button  ④.

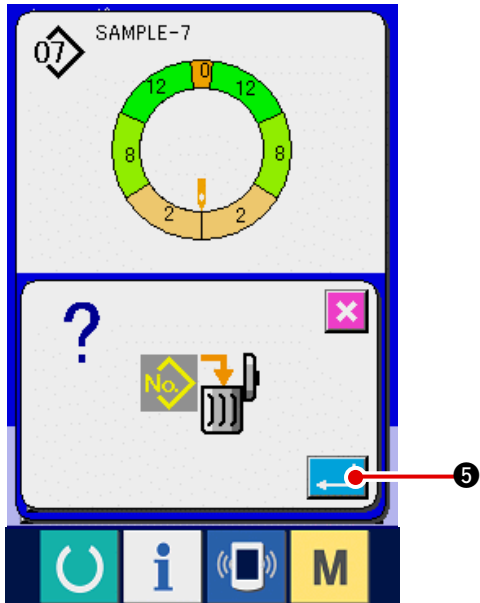

When deleting it, the pattern does not return to the former one. So, be careful.



5) Press ENTER button  5.

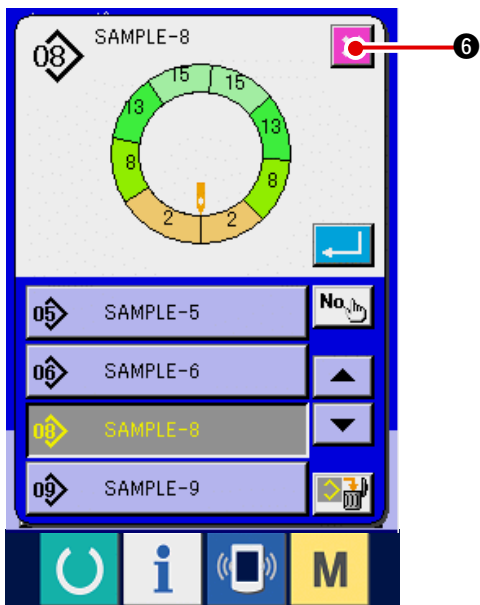

6) Press CANCEL button  6.

6. OPERATION OF THE SEWING MACHINE (SEMI-AUTOMATIC APPLICATION VOLUME)

6-1 Correcting the pattern

(1) Changing the needle thread tension of specified step <Compensation thread tension setting>

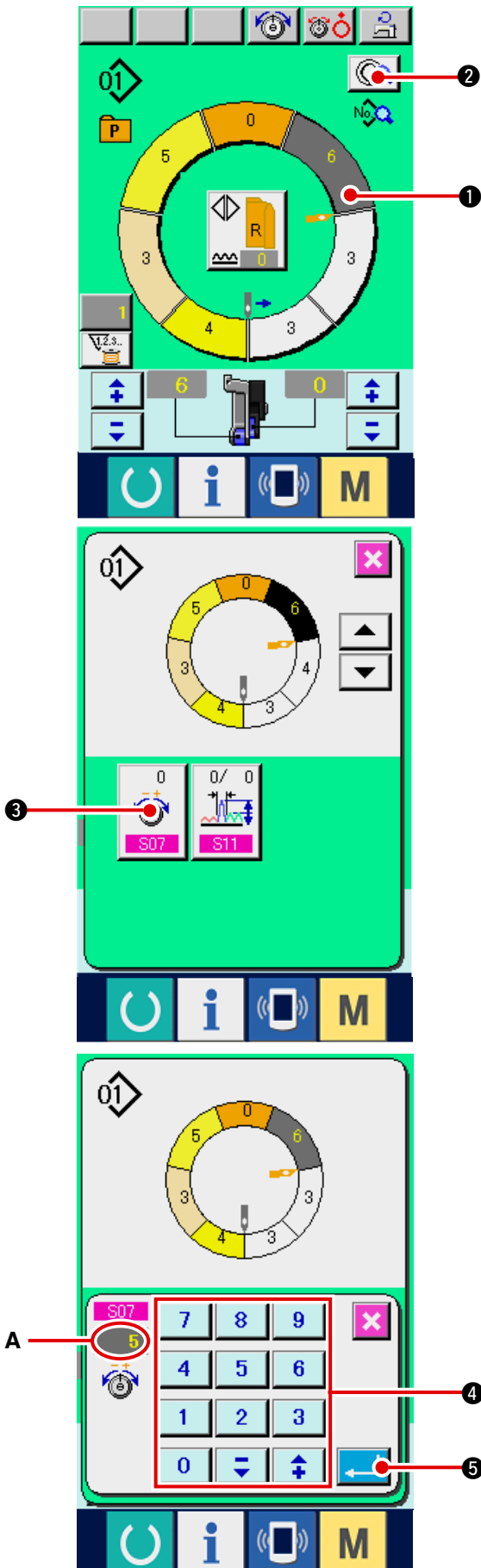

* This is the function to add the needle thread tension of the specified step to the overall needle thread tension as much as "compensation needle thread tension set value".

1) Press STEP SELECTION button

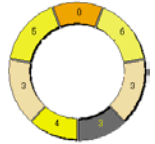

① to select the step.

2) Press STEP DETAILS button



②.

3) Press COMPENSATION THREAD TENSION

button



③.

4) Press ten keys



④

to change compensation thread tension set value **A**.

5) Press ENTER button



⑤.

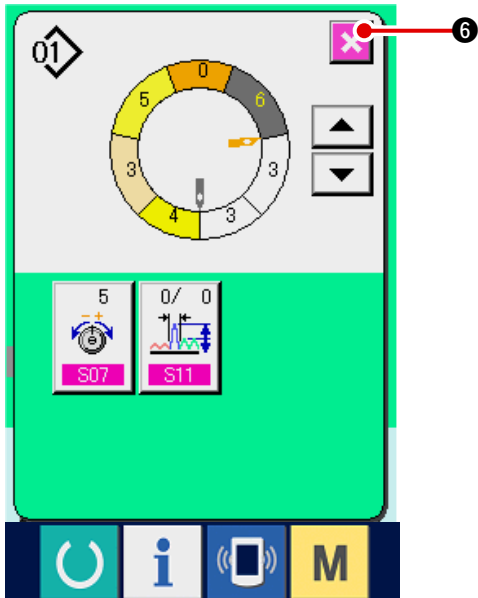

6) Press CANCEL button  ⑥.

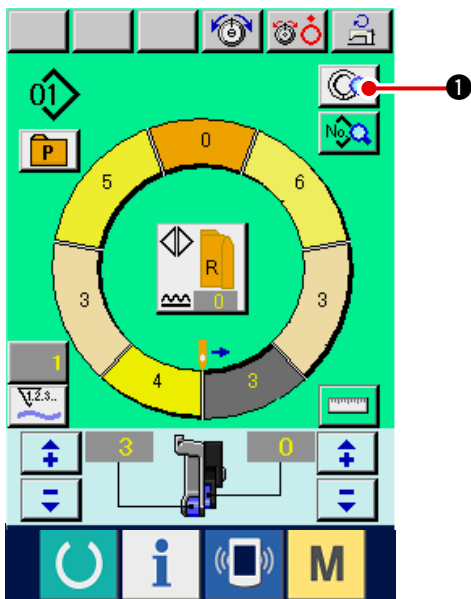

(2) Changing the pitch of specified step <Compensation pitch setting>

- * The state that is possible to change the step on the sewing screen is the state that step 1 is selected before starting sewing.
- * This is the function to add the pitch of the specified step to the overall pitch as much as the compensation pitch set value.

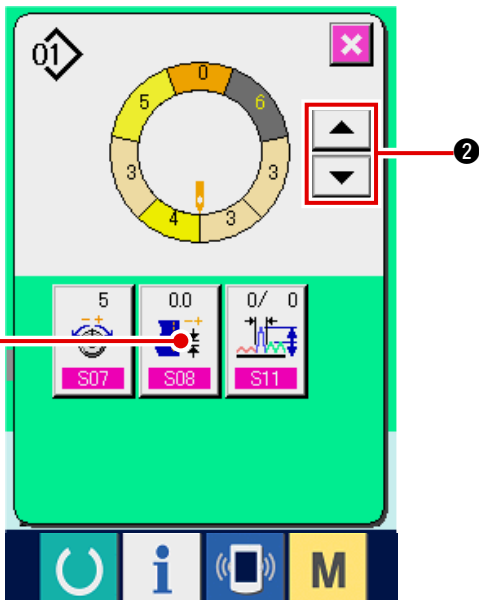

1) Press STEP DETAILS button  ① in the state that step 1 is selected.



2) Press STEP FEED/RETURN buttons   ② to select the step to be changed.

3) Press COMPENSATION PITCH button  ③.

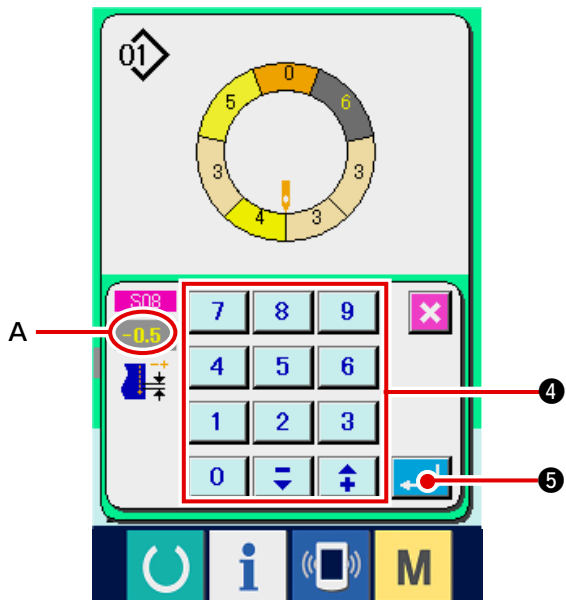

4) Press ten keys

7	8	9
4	5	6
1	2	3
0	↓	↑

 ④ to change compensation pitch set value A.

5) Press ENTER button ⑤.

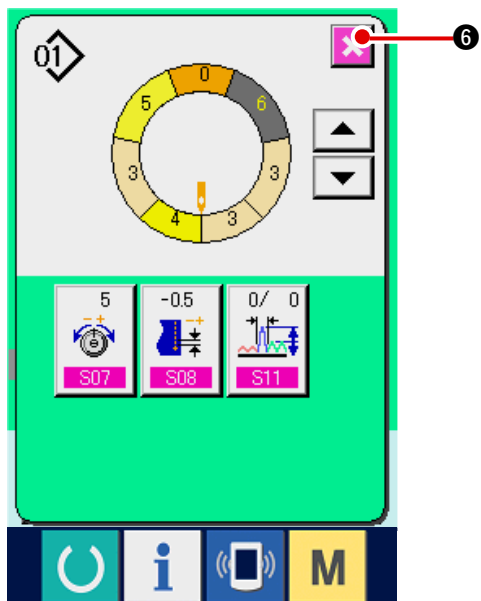

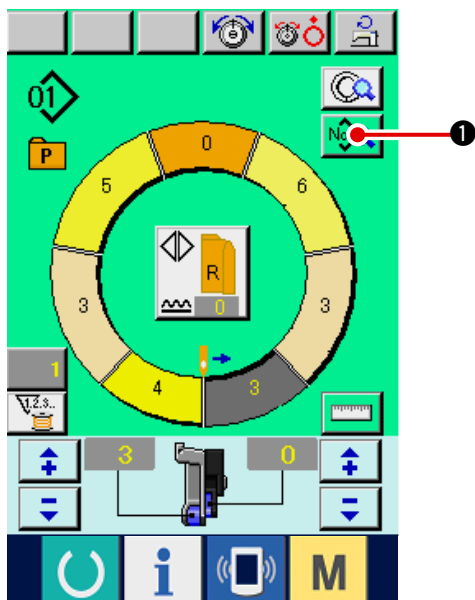

6) Press CANCEL button ⑥.

(3) Increasing/decreasing the shirring amount of all steps <Shirring amount increase/decrease setting>

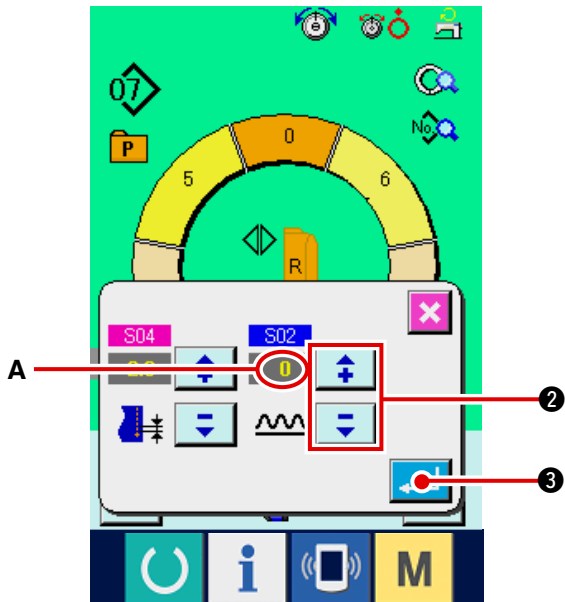

1) Press SEWING DATA DISPLAY button ①.



2) Press "+"/ "-" buttons   ② to change shirring amount increase/decrease set value A.

3) Press ENTER button  ③.

(4) Increasing/decreasing the shirring amount immediately after changeover of step <Compensation shirring amount setting>

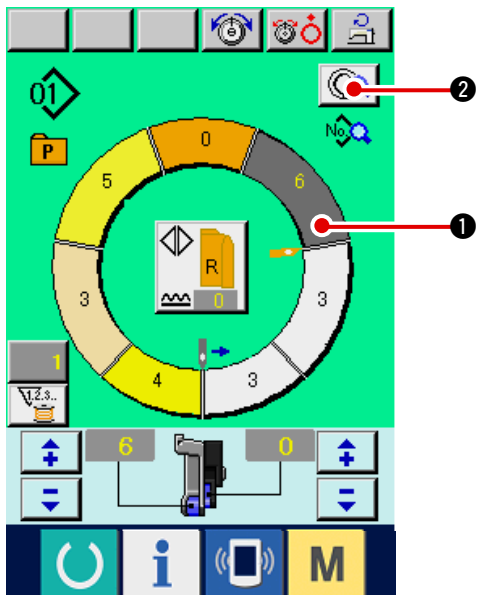

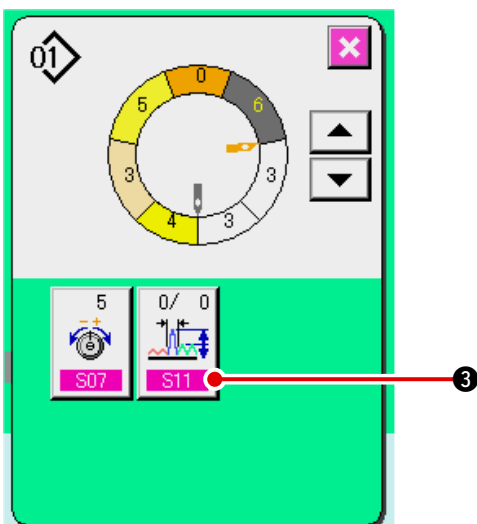

1) Press STEP SELECTION button  ① to select the step.

2) Press STEP DETAILS button  ②.

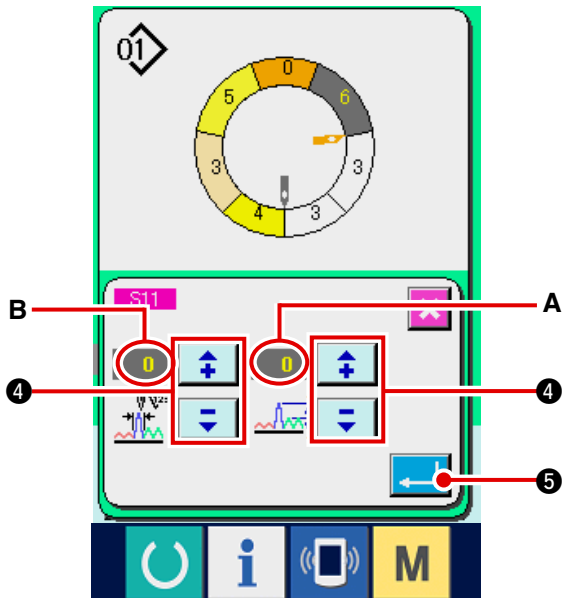

3) Press COMPENSATION SHIRRING AMOUNT button  ③.



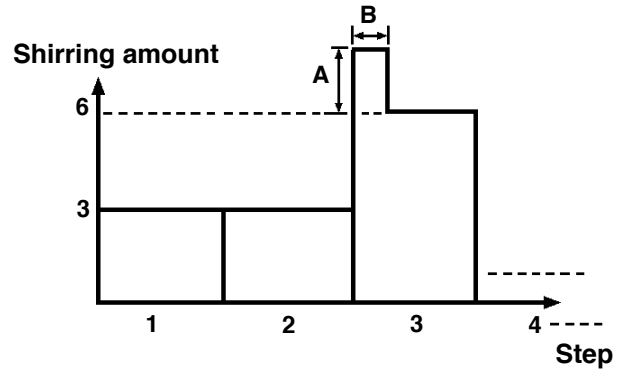

- 4) Press "+"/ "-" buttons   ④ to change compensation shirring amount set value **A** and number of stitches of compensation shirring amount **B**.



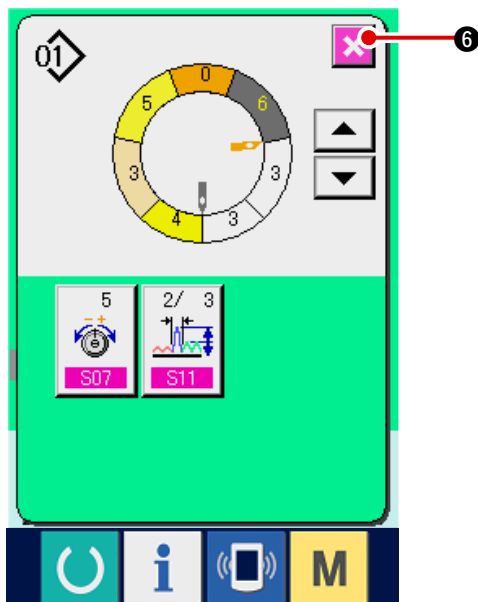



- Compensation shirring amount is the shirring amount to add to the shirring amount of the step after changeover at the time of step changeover.
- Number of stitches of shirring amount compensation is the number of stitches of the section of number of stitches to add the compensation shirring amount from the step changeover.

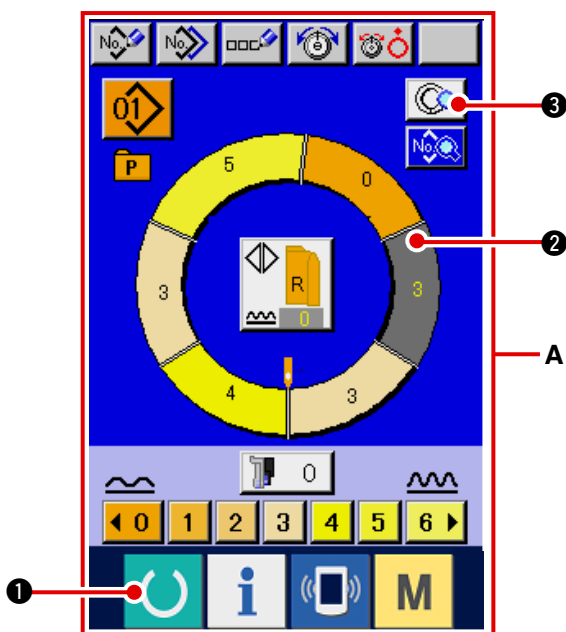

- 5) Press ENTER button  ⑤.
- 6) Press CANCEL button  ⑥.

(5) Adding the step <Step addition>



- 1) Press READY key  ① to change over the screen to data input screen **A**.
- 2) Press STEP SELECTION button  ② to select the step which is one before the step addition position.
- 3) Press STEP DETAILS button  ③.

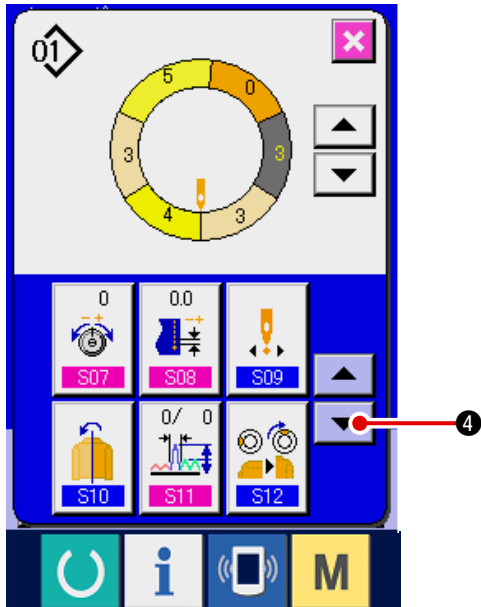

4) Press DOWN SCROLL button  ④.

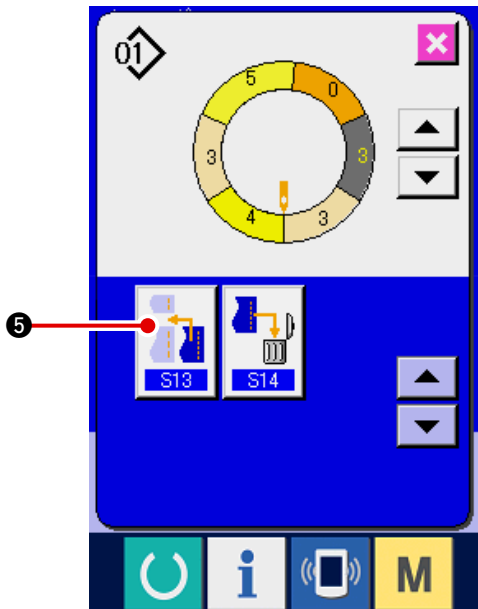

5) Press STEP ADDITION button  ⑤.

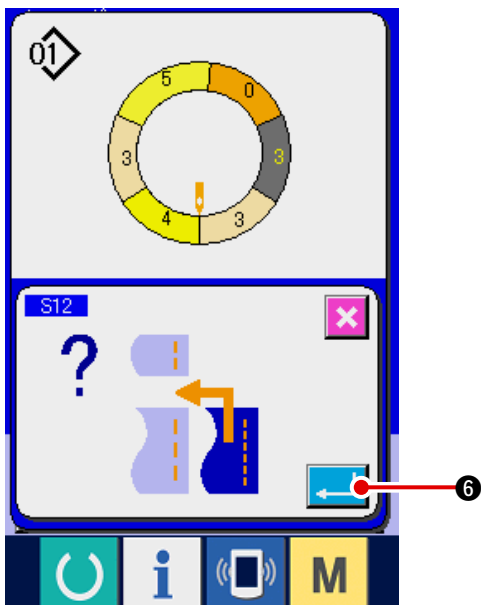

6) Press ENTER button  ⑥.

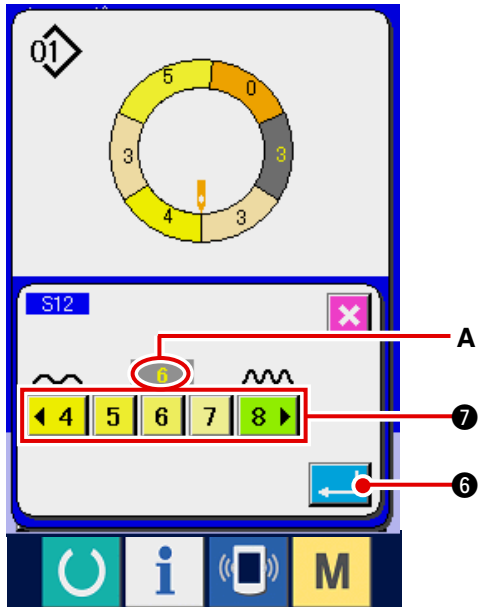

6) Press SHIRRING AMOUNT buttons



7) to change shirring amount set value **A**.

7) Press ENTER button  **6**.

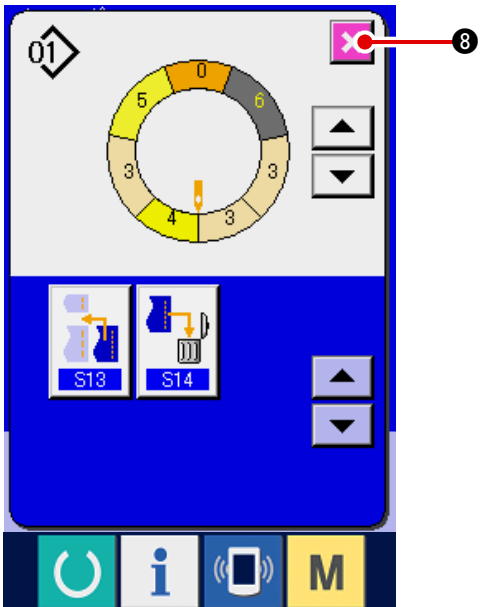

5) Press CANCEL button  **8**.

(6) Deleting the step <Step deletion>

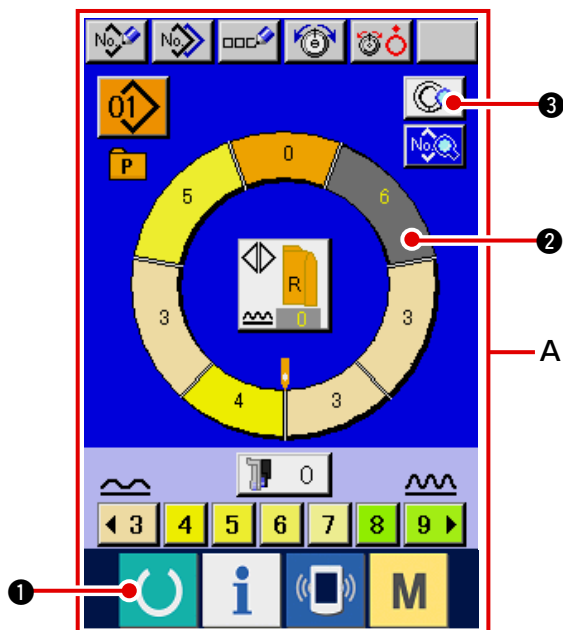

1) Press READY key  **1** to change over the screen to data input screen **A**.

2) Press STEP SELECTION button



2 to select the step to be deleted.

3) Press STEP DETAILS button  **3**.

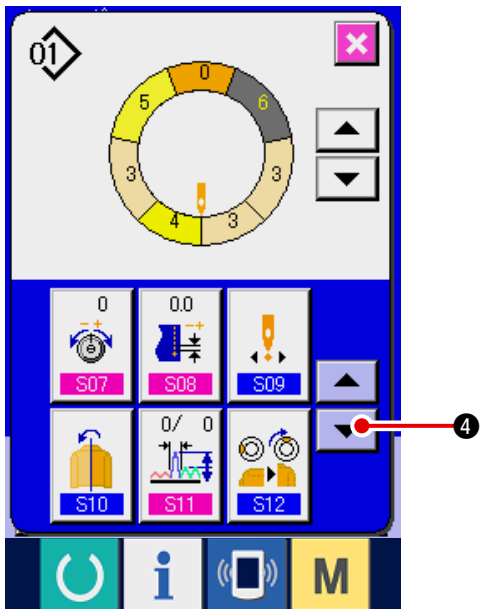

4) Press DOWN SCROLL button  ④.

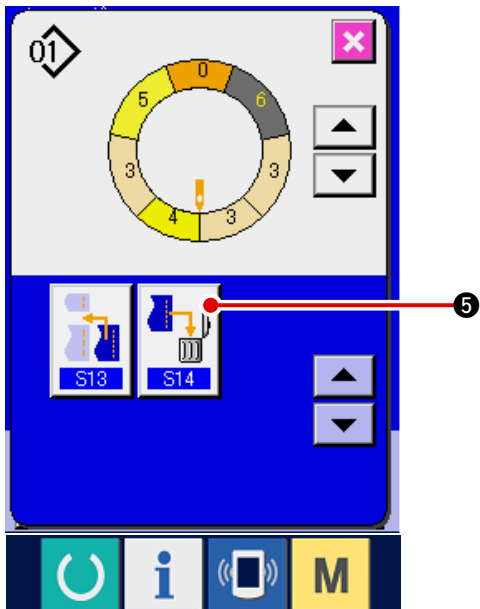

5) Press STEP DELETION button  ⑤.

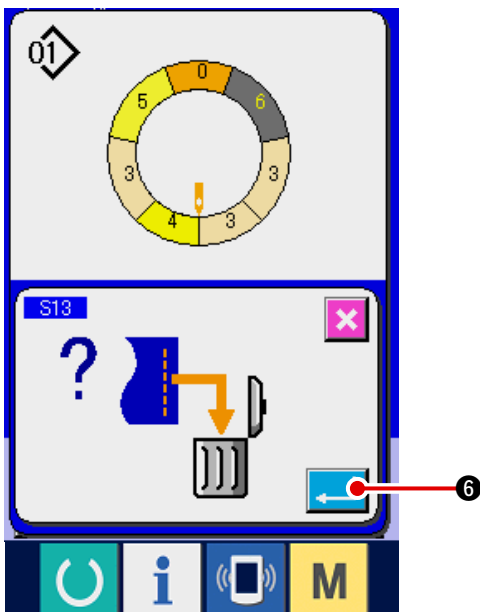

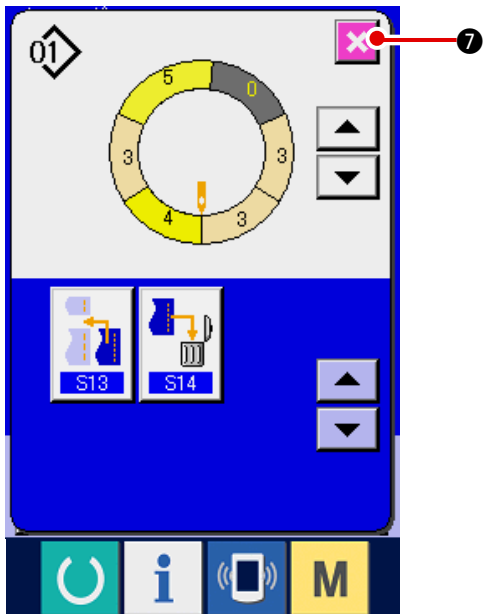

6) Press ENTER button  ⑥.

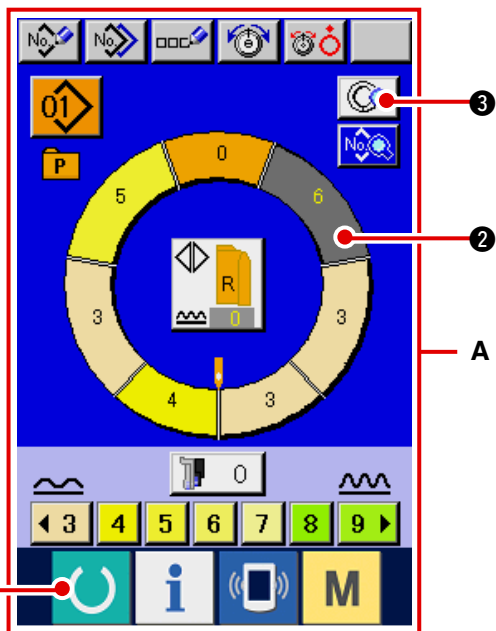

7) Press CANCEL button  7.

(7) Changing the start position of program <Start position change>



1) Press READY key  1 to change over the screen to data input screen A.

2) Press STEP SELECTION button

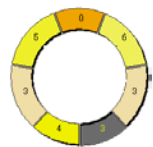

 2 to select the step which is the start position you desire.

3) Press STEP DETAILS button  3.

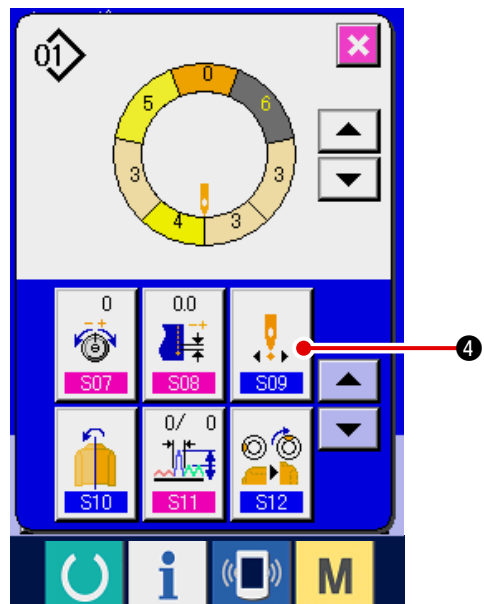

4) Press START POSITION CHANGE button



 4.

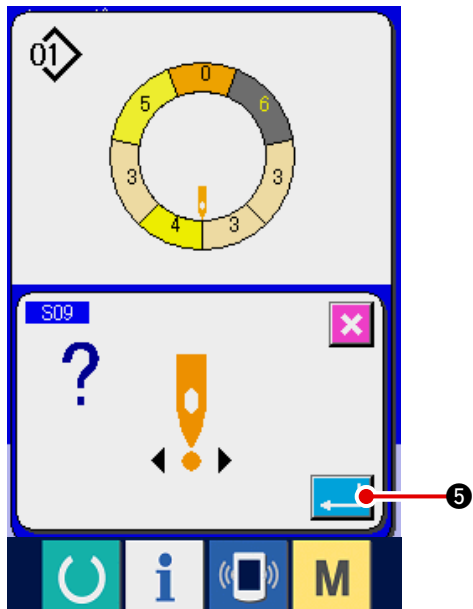

5) Press ENTER button  ⑤.

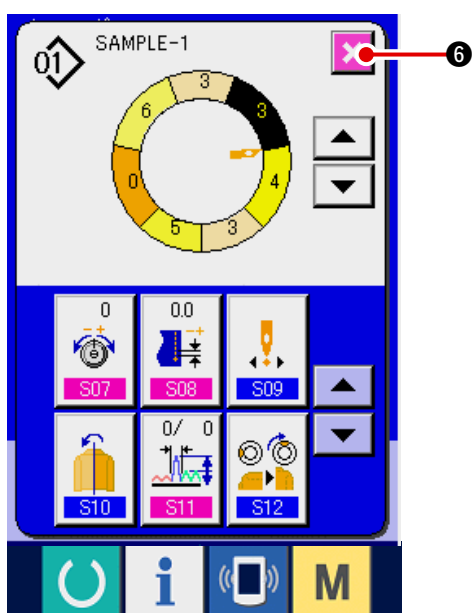

6) Press CANCEL button  ⑥.

(8) Mirroring the program of one sleeve and creating the program of the other sleeve

<Mirroring function>

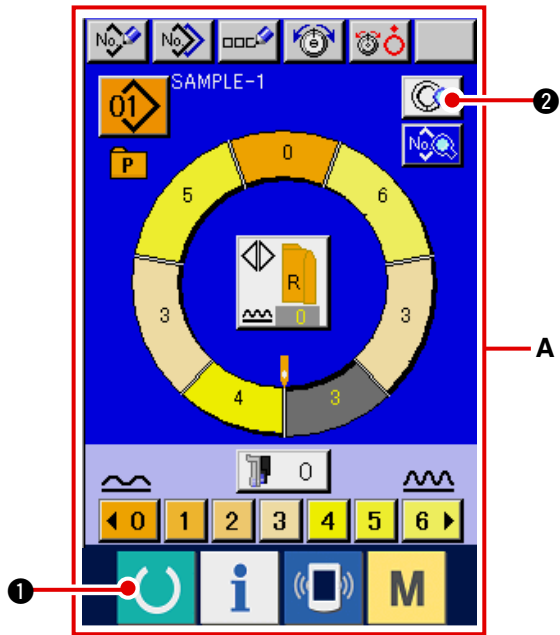

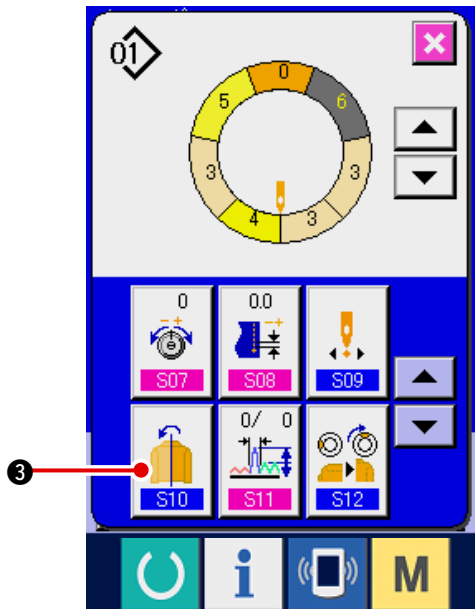

1) Press READY key  ① to change over the screen to data input screen A.

2) Press STEP DETAILS button  ②.

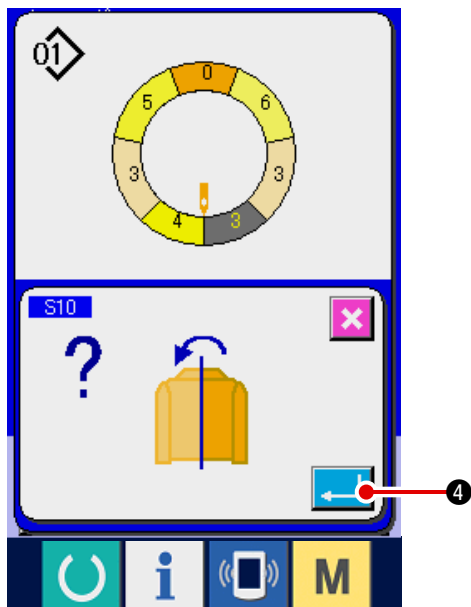

3) Press MIRRORING button  ③.



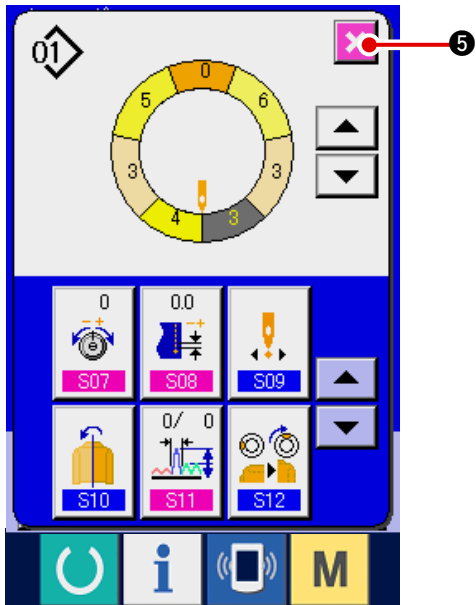

4) Press ENTER button  ④.

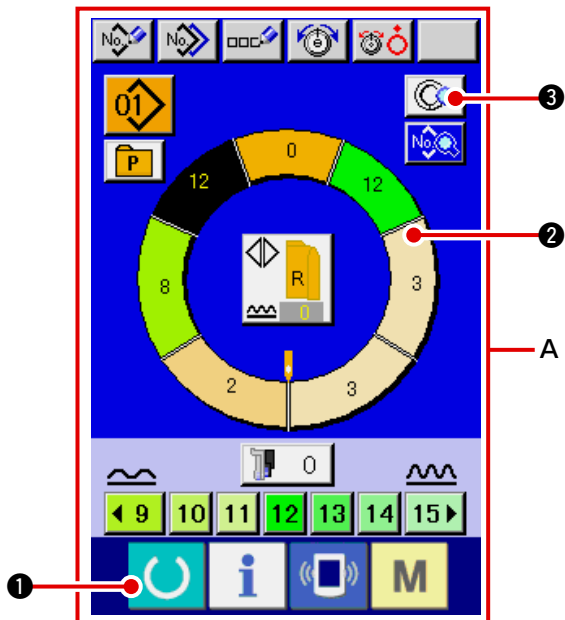

5) Press CANCEL button  5.

(9) Changing the top notch position of program <Top notch position change>



1) Press READY key  1 to change over the screen to data input screen A.

2) Press STEP SELECTION button

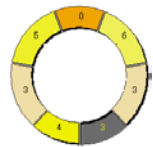

2 to select the step which is the top notch position you desire.

3) Press STEP DETAILS button  3.

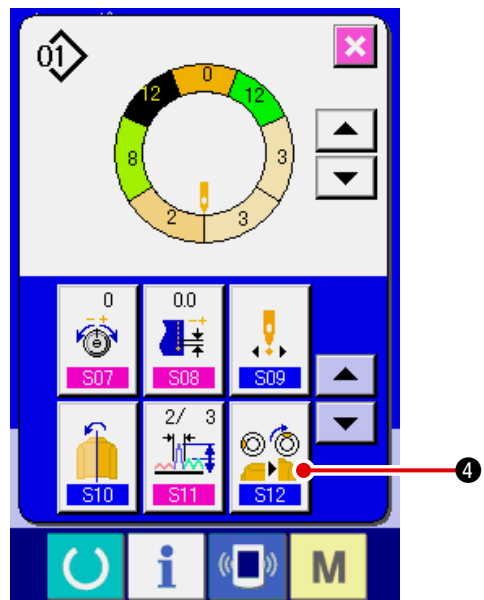

4) Press TOP NOTCH POSITION CHANGE button



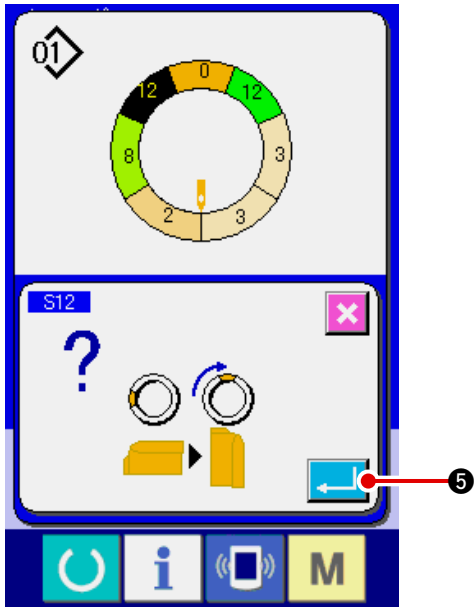

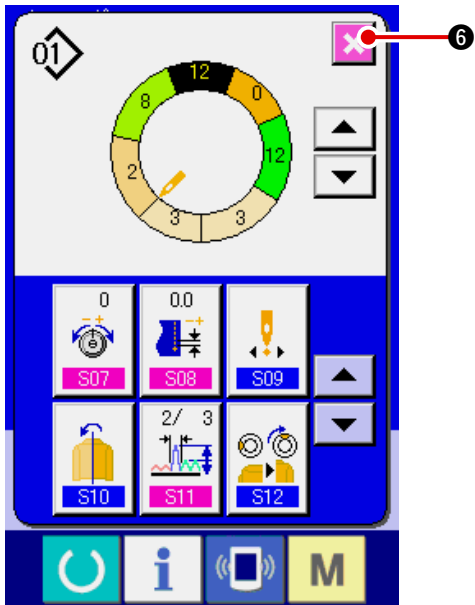

5) Press ENTER button  ⑤.

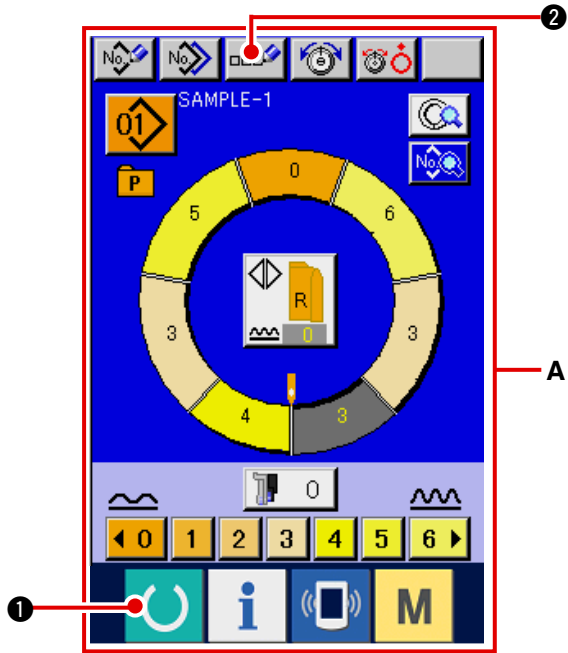

6) Press CANCEL button  ⑥.

(10) Naming the pattern <Data name setting>





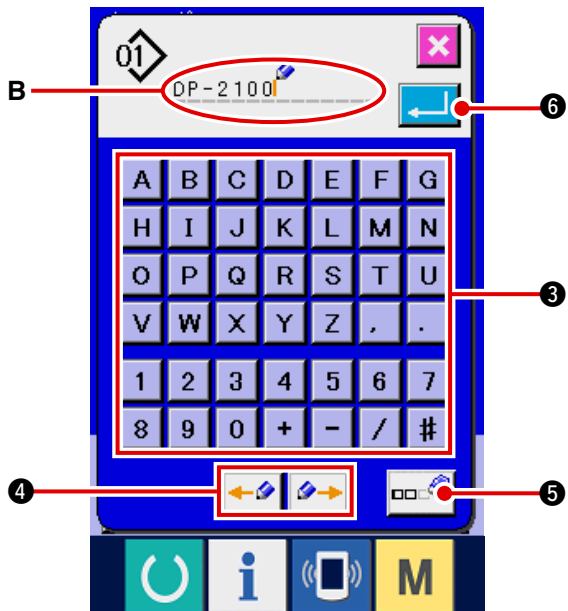

- 1) Press READY key  ① to change over the screen to data input screen **A**.
- 2) Press LETTER INPUT button  ②.



- 3) Press LETTER buttons

A	B	C	D	E	F	G
H	I	J	K	L	M	N
O	P	Q	R	S	T	U
V	W	X	Y	Z	.	.
1	2	3	4	5	6	7
8	9	0	+	-	/	#

 ③ to input the letter.

- 4) Cursor in the inputted letter display **B** can be moved with CURSOR MOVE, LEFT (RIGHT) buttons  () ④.
- 5) When DELETION button  ⑤ is pressed, the letter on the left side of cursor disappears.
- 6) Press ENTER button  ⑥.

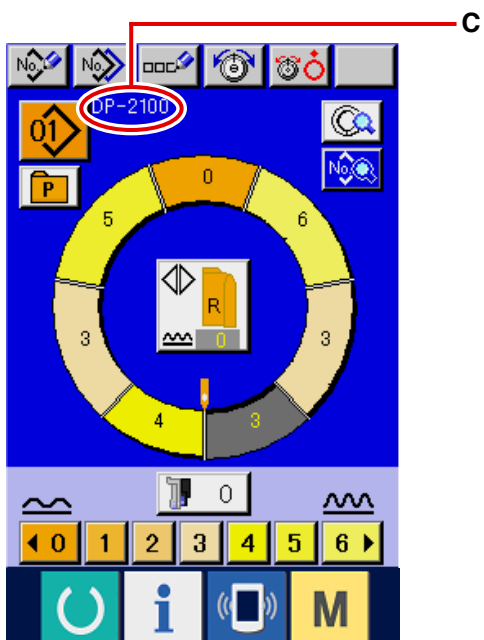

- 7) Inputted letters are displayed in the pattern name display section **C**.

6-2 Copying the pattern <Pattern copy>

(1) Pattern copy in semi-automatic mode <Copy to semi-automatic>

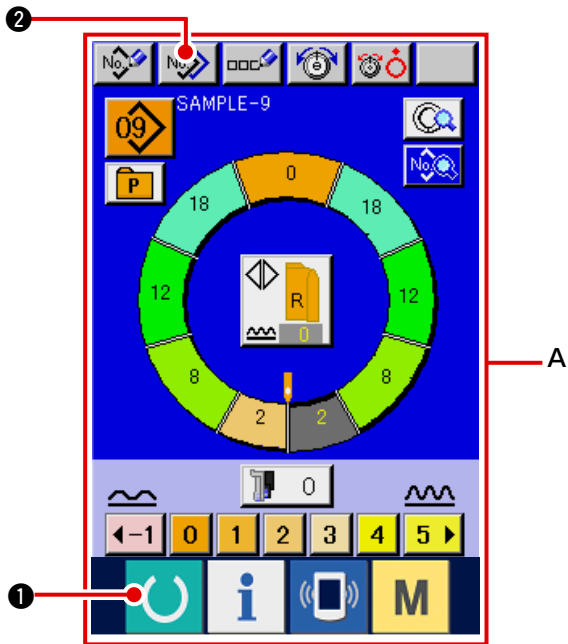

1) Press READY key  ① to change over the screen to data input screen A.

2) Press PATTERN COPY button  ②.

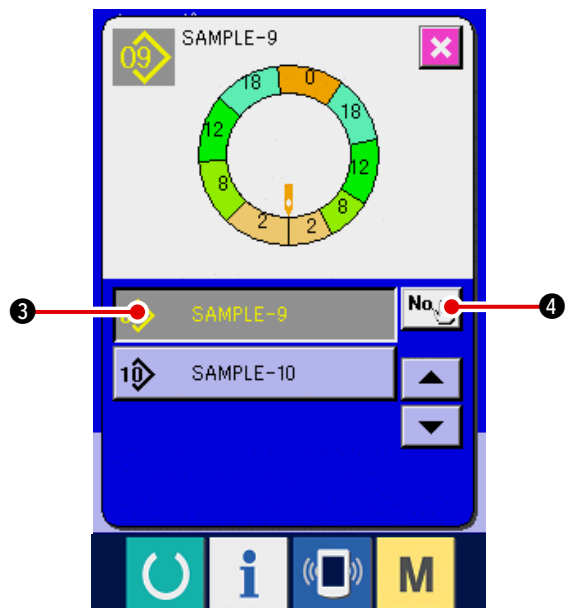

3) Press PATTERN No. button  ③ to select the pattern of copy source.

4) Press COPY DESTINATION INPUT button  ④.

5) Press ten keys

7	8	9
4	5	6
1	2	3
0	→	←

 ⑤ to input the pattern No. of copy destination.

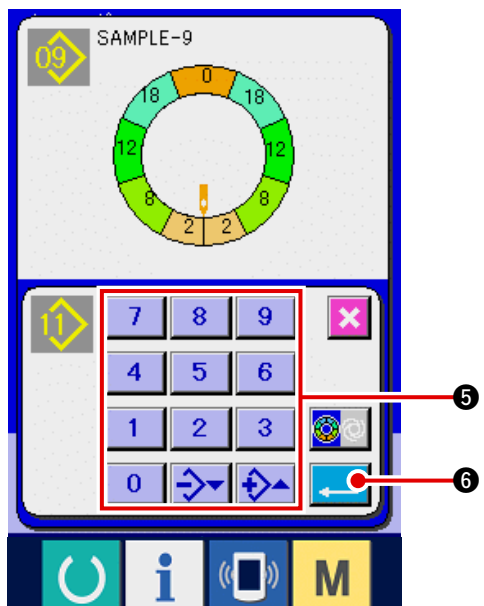

6) Press ENTER button  ⑥.

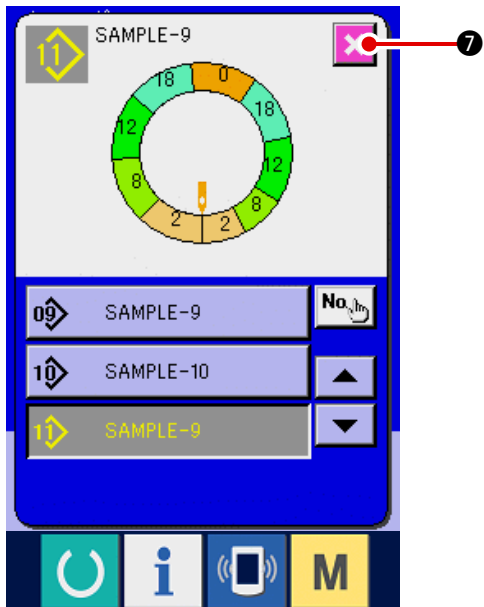

7) Press CANCEL button  7.

* When the number of patterns that have been registered of fully-automatic is 99 patterns, the display is automatically changed over and copied to semi-automatic.

(2) Pattern copying from semi-automatic to fully-automatic <Copy to fully-automatic>

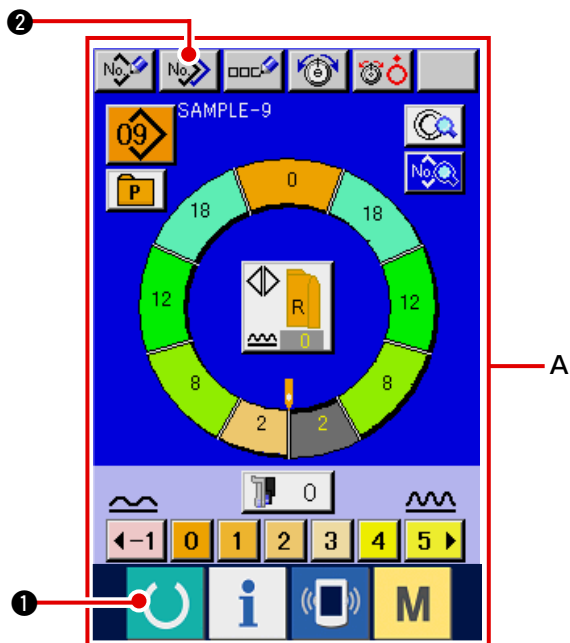

1) Press READY key  1 to change over the screen to data input screen A.

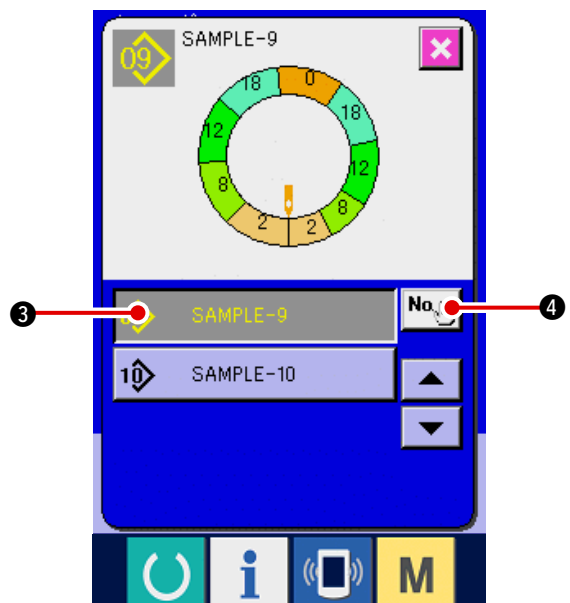

2) Press PATTERN COPY button  2.

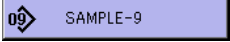

3) Press PATTERN No. button  3 to select the pattern of copy source.

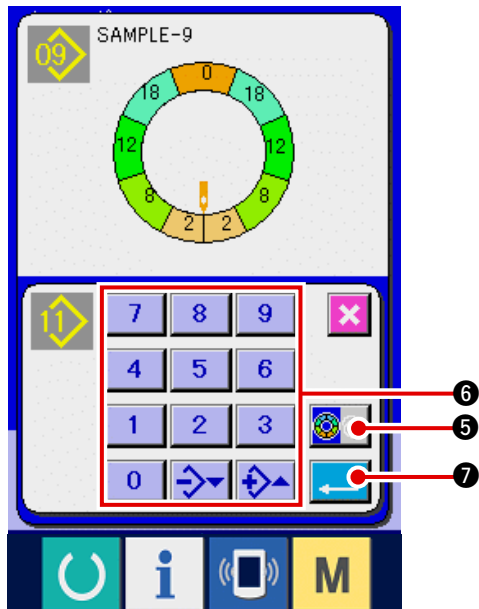
4) Press COPY DESTINATION INPUT button  4.



5) Press SEMI AUTO/FULL AUTO CHANGEOVER button  ⑤ to display FULL-AUTO .

6) Press ten keys

7	8	9
4	5	6
1	2	3
0	↔	↔

 ⑥ to input the pattern No. of copy destination.

7) Press ENTER button  ⑦.

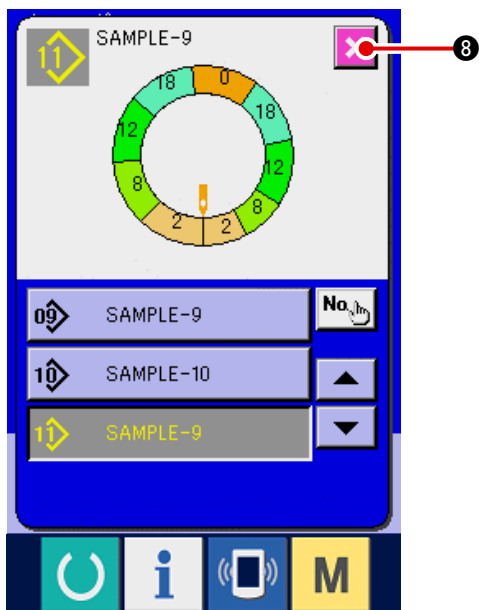



8) Press CANCEL button  ⑧.

* When the number of patterns that have been registered of fully-automatic is 99 patterns, the display is automatically changed over and copied to semi-automatic.

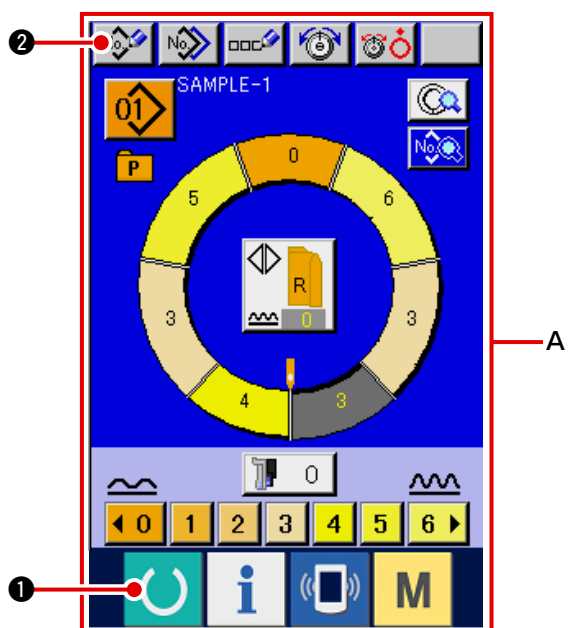
6-3 Creating the new pattern <New pattern creation>



1) Press READY key  ① to change over the screen to data input screen A.

2) Press PATTERN NEW REGISTER button  ②.

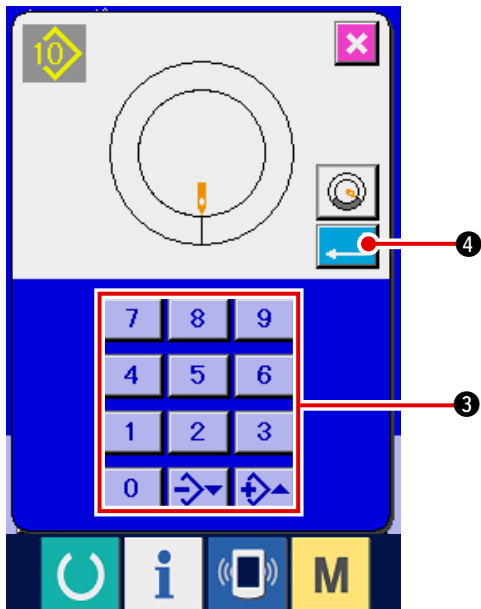

3) Press ten keys

7	8	9
4	5	6
1	2	3
0	↔	↔

 ③ to input the new pattern No.

4) Press ENTER button ④.

5) Change the pitch.

Refer to **"5-6 (2) Changing the pitch"**.

6) Select left/right alternate sewing.

Refer to **"5-5 (4) Select left/right alternate sewing"**.

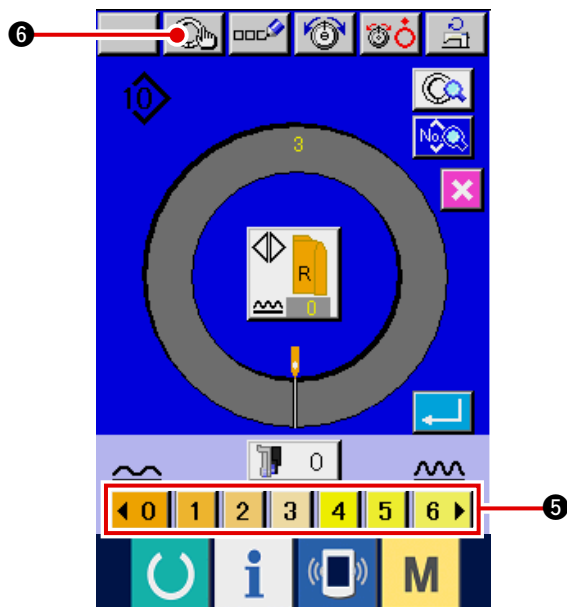

7) Press SHIRRING AMOUNT button

◀	0	1	2	3	4	5	6	▶
---	---	---	---	---	---	---	---	---

 ⑤ to input shirring amount.

8) Press STEP DETERMINATION button ⑥ to determine the input data.

9) Repeat procedures 7) and 8).

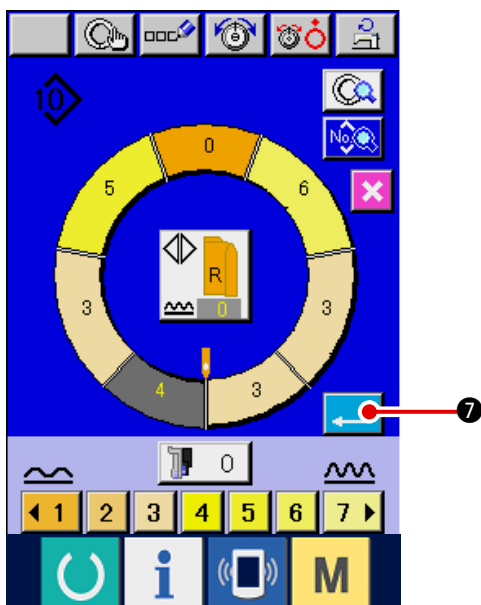

10) After inputting shirring amount of the last step, press ENTER button ⑦ and the program of inputted sleeve is registered to the pattern. At this time, the program of the other sleeve is automatically created by means of mirroring.

6-4 Using the other functions

(1) Directly calling the pattern from the sewing screen <Direct pattern selection>

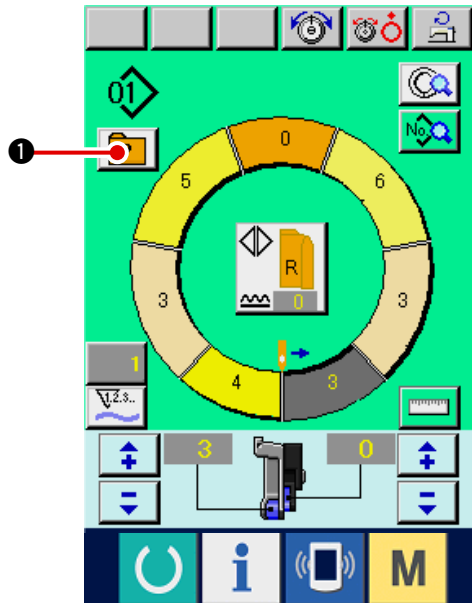

When registering the patterns which are frequently used to the DIRECT SELECTION button, pattern selection can be simply performed from the operating screen by only pressing the button.

* For the way of registering the pattern to DIRECT SELECTION button, refer to "[12. Registering the pattern to the direct button](#)".

1) Press DIRECT SELECTION button  ①.

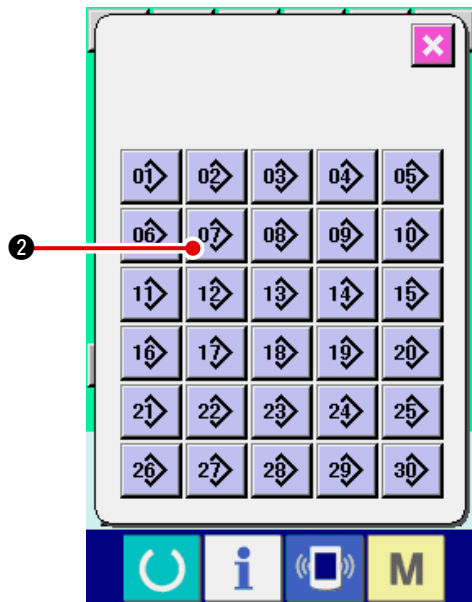

2) Press PATTERN SELECTION button  ② of the pattern to be called.

(2) Adjust the STEP SELECTION button to the shape of sleeve <Measure function>

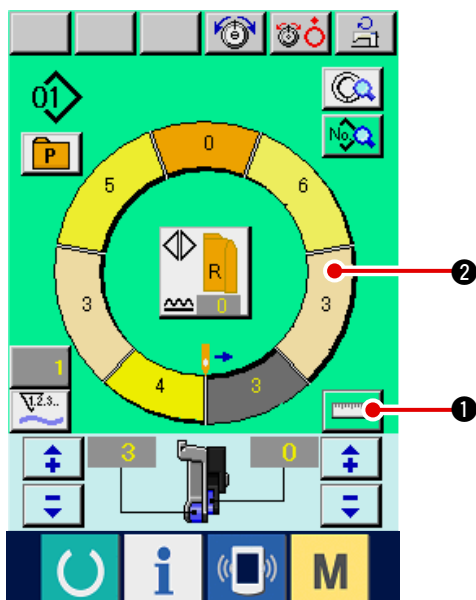

1) Press MEASURE button  ①.

2) Perform sewing.

Refer to "[5-5 \(5\) Perform sewing](#)".

3) Data of the length of measured step is reflected







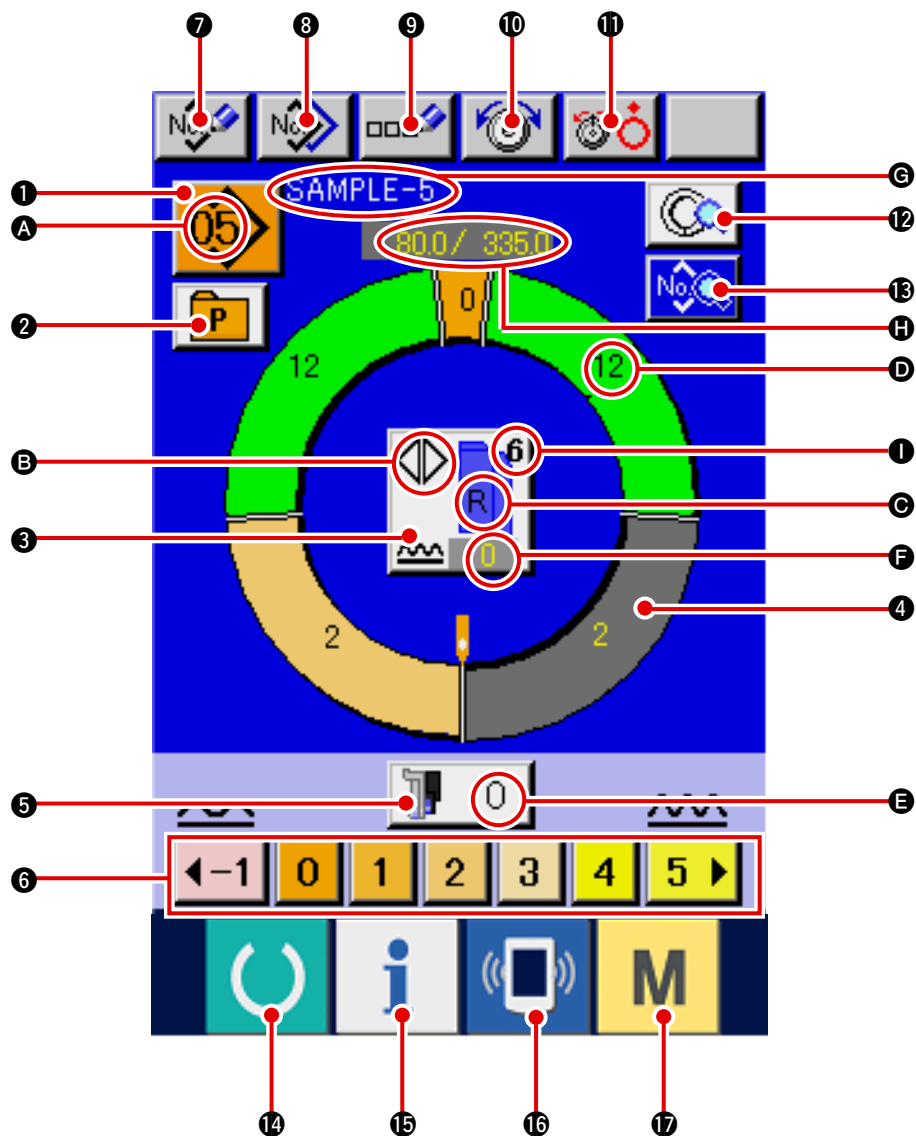



to STEP SELECTION button  ②.









7. OPERATION OF THE SEWING MACHINE (FULLY-AUTOMATIC BASIC VOLUME)

7-1 Data input screen



No.	Button	Name of button	Description
①		PATTERN SELECTION button	Pattern No. being selected at present is displayed on the button and when the button is pressed, pattern No. change screen is displayed.
②		DIRECT SELECTION button	When the button is pressed, list screen of pattern Nos. which have been registered to the direct selection button.
③		LEFT/RIGHT ALTERNATE SEWING SELECTION button	Method of changeover of program (for right sleeve and left sleeve) during sewing is selected.
④		STEP SELECTION button	When the button is pressed, step is in the selective state.
⑤		SHIRRING AMOUNT FOR AUXILIARY FEED button	When the button is pressed, shirring amount for auxiliary feed change screen is displayed.
⑥		SHIRRING AMOUNT button	When the button is pressed, shirring amount of step being selected is changed.

No.	Button	Name of button	Description
7		PATTERN NEW REGISTER button	When the button is pressed, pattern No. new register screen is displayed.
8		PATTERN COPY button	When the button is pressed, sewing data copy screen is displayed.
9		LETTER INPUT button	When the button is pressed, letter input screen is displayed.
10		NEEDLE THREAD TENSION SETTING	When the button is pressed, needle thread tension change screen button is displayed.
11		DISK RISE button	When the button is pressed, thread tension disk No. 1 rises. (Turn OFF the base tension during U11 waiting.)
12		STEP DETAILS button	When the button is pressed, list of sewing data corresponding to the step being selected is displayed.
13		SEWING DATA DISPLAY button	List of sewing data corresponding to the pattern No. being selected is displayed.
14		READY key	Changeover of data input screen and sewing screen is performed.
15		INFORMATION key	Changeover of data input screen and information screen is performed.
16		COMMUNICATION key	Changeover of data input screen and communication screen is performed.
17		MODE key	Changeover of input screen and mode changeover screen to perform various details setting is performed.

Symbol	Display	Name of display	Description
A		PATTERN No. display	Pattern No. is displayed.
B		ALTERNATE SEWING display	This is displayed when alternate sewing is selected.
C		LEFT/RIGHT SLEEVE display	R display : Program for right sleeve is called. L display : Program for left sleeve is called.
D		SHIRRING AMOUNT display	Shirring amount is displayed.
E		SHIRRING AMOUNT FOR AUXILIARY FEED display	Shirring amount of auxiliary feed is displayed.
F		SHIRRING AMOUNT INCREASE/DECREASE SET VALUE display	Shirring amount increase/decrease set value is displayed.
G		PATTERN NAME display	Pattern name is displayed.
H		STEP LENGTH/TOTAL LENGTH display	Step length/total length are displayed.
I		SEWING SIZE display	Sewing size is displayed.

7-2 Sewing screen

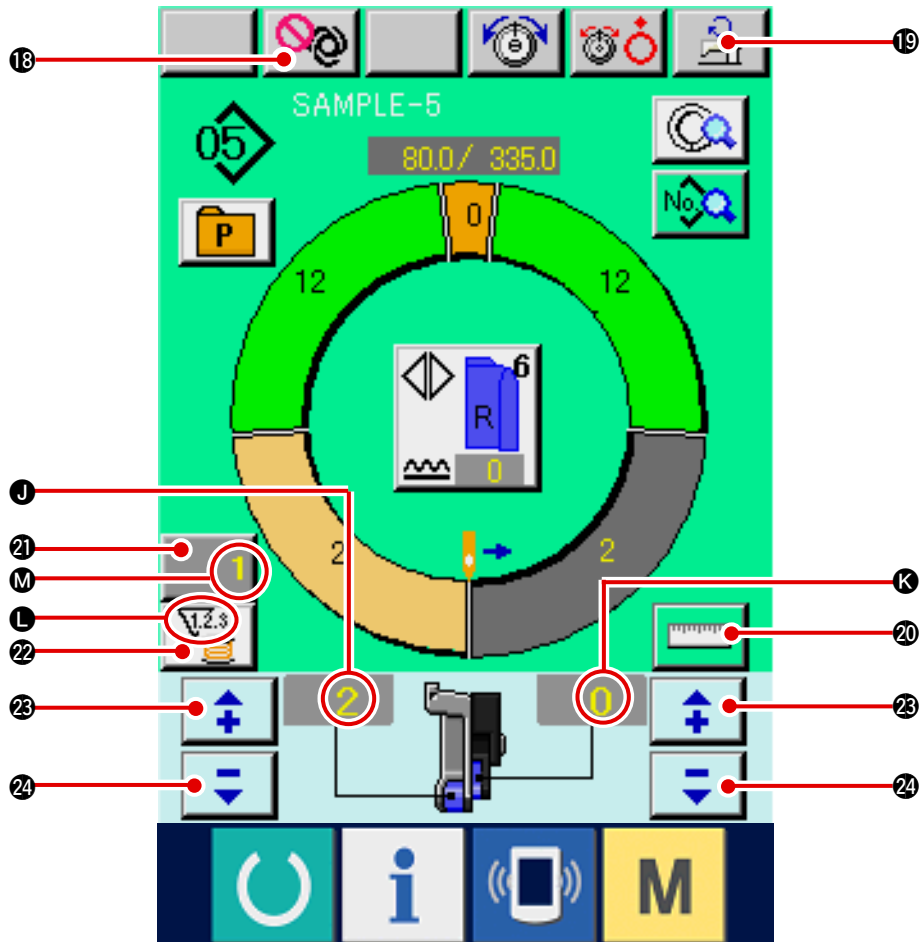

No.	Display	Name of button	Description
18		FULL AUTO INTERRUPTION button	When the button is pressed, fully-automatic is interrupted and measuring is stopped.
19		MAX. SEWING SPEED SETTING button	When the button is pressed, max. sewing speed setting screen is displayed.
20		MEASURE button	When the button is pressed, length of each step is measured during sewing and reflected to the icon display shape of step selection button.
21		COUNTER SETTING button	When the button is pressed, bobbin/No. of pcs. counter setting screen is displayed.
22		COUNTER SELECTION button	When the button is pressed, bobbin/No. of pcs. counter is changed over.
23		"+" button	When the button is pressed, the numeral is increased.
24		"-" button	When the button is pressed, the numeral is decreased.



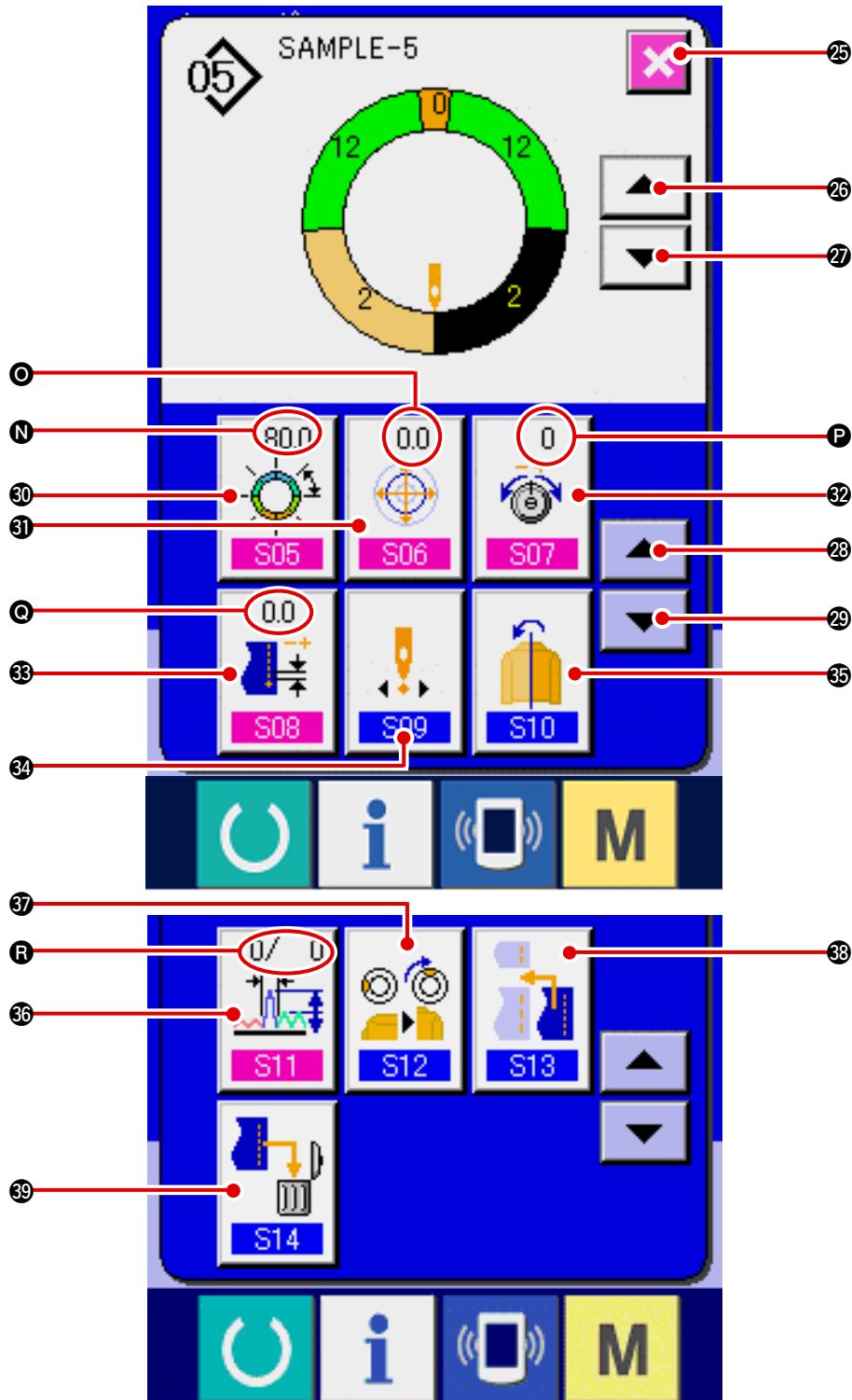

Symbol	Display	Name of display	Description
J		SHIRRING AMOUNT display	Shirring amount is displayed.
K		SHIRRING AMOUNT FOR AUXILIARY FEED display	Shirring amount of auxiliary feed is displayed.
L		COUNTER display	display : This is displayed when bobbin counter is used. display : This is displayed when No. of pcs. counter is used.
M		COUNTER SET VALUE display	Set value of counter is displayed.

7-3 Detailed data input screen

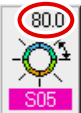

No.	Button	Name of button	Description
25		CANCEL button	When the button is pressed, step details screen is closed.
26		STEP FEED button	When the button is pressed, selection step advances by one.
27		STEP RETURN button	When the button is pressed, selection step returns by one.
28		DETAILS SELECTION SCREEN FEED button	When the button is pressed, details selection screen scrolls forward.
29		DETAILS SELECTION SCREEN RETURN button	When the button is pressed, details selection screen scrolls backward.

No.	Button	Name of button	Description
30		LENGTH BETWEEN STEPS SETTING button	When the button is pressed, length between steps setting screen is displayed.
31		GRADING VALUE SETTING button	When the button is pressed, grading value setting screen is displayed.
32		COMPENSATION THREAD TENSION SETTING button	When the button is pressed, compensation thread tension setting screen is displayed.
33		COMPENSATION PITCH SETTING button	When the button is pressed, compensation pitch setting screen is displayed.
34		START POSITION CHANGE button	When the button is pressed, start position change screen is displayed.
35		MIRRORING button	When the button is pressed, mirroring screen is displayed.
36		COMPENSATION SHIRRING AMOUNT SETTING button	When the button is pressed, compensation shirring amount setting screen is displayed.
37		TOP NOTCH POSITION CHANGE button	When the button is pressed, top notch position change screen is displayed.
38		STEP ADDITION button	When the button is pressed, step addition screen is displayed.
39		STEP DELETION button	When the button is pressed, step deletion screen is displayed.

Symbol	Display	Name of display	Description
N		LENGTH BETWEEN STEPS display	Set value of length between steps is displayed.
O		GRADING VALUE display	Grading value is displayed.
P		COMPENSATION THREAD TENSION display	Set value of compensation thread tension is displayed.
Q		COMPENSATION PITCH display	Set value of compensation pitch is displayed.
R		COMPENSATION SHIRRING AMOUNT display	Set value of compensation shirring amount is displayed.

7-4 Feed amount

The explanation is given for the feed amount of the sewing machine.

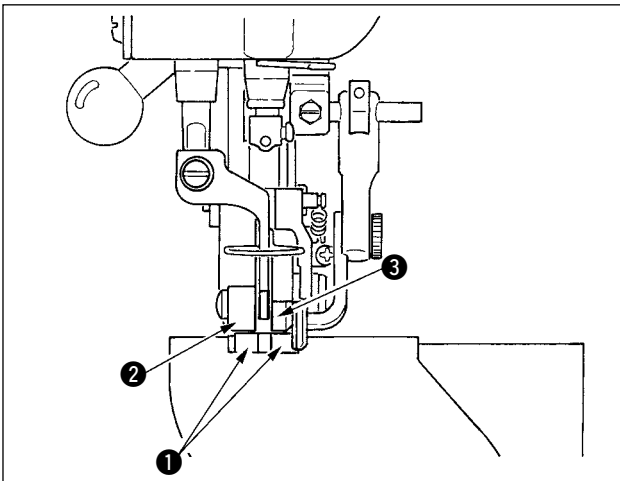

Feed amount on the operation consists of the three kinds of feed amounts, bottom feed amount (pitch), main feed amount (pitch + shirring amount) and auxiliary feed amount (pitch + shirring amount + shirring amount for auxiliary feed).

In case of **A**, when pitch (S04) is set to 2.0, bottom feed belt ① moves 2.0 mm per rotation of the sewing machine (1 stitch).

In case of **B**, when shirring amount is set to 3, main feed belt ② moves 2.3 mm per rotation of the sewing machine (1 stitch).

This means that set value "1" of shirring amount (main feed) is in steps of 0.1 mm and when the set value is converted to mm, $3 \times 0.1 = 0.3$ mm is calculated. This value is added to pitch (bottom feed) and the total value becomes the moving amount of the main feed belt.

$$\begin{aligned} \text{Main feed amount} &= \text{pitch} + \text{shirring amount} \\ 2.3 \text{ mm} &= 2.0 \text{ mm} + 0.3 \text{ mm} \end{aligned}$$

In case of **C**, when shirring amount for auxiliary feed is set to 2, auxiliary feed belt ③ moves 2.5 mm per rotation of the sewing machine (1 stitch).

This means that set value "1" of shirring amount for auxiliary feed (auxiliary feed) is in steps of 0.1 mm and when the set value is converted to mm, $2 \times 0.1 = 0.2$ mm is calculated. This value is added to the main feed amount and the total value becomes the moving amount of the auxiliary belt.

$$\begin{aligned} \text{Auxiliary feed amount} &= \text{main feed amount} + \text{shirring amount for auxiliary feed} \\ 2.5 \text{ mm} &= 2.3 \text{ mm} + 0.2 \text{ mm} \end{aligned}$$

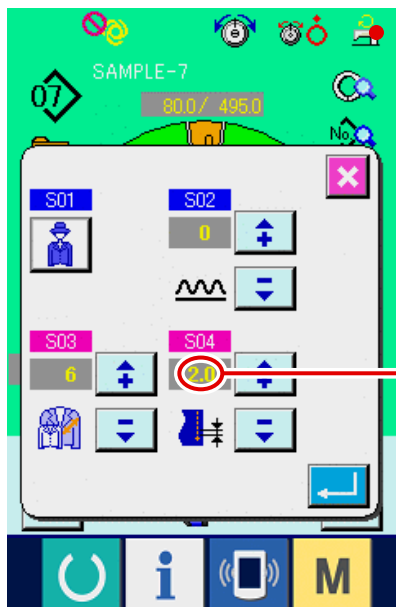

Pitch setting screen

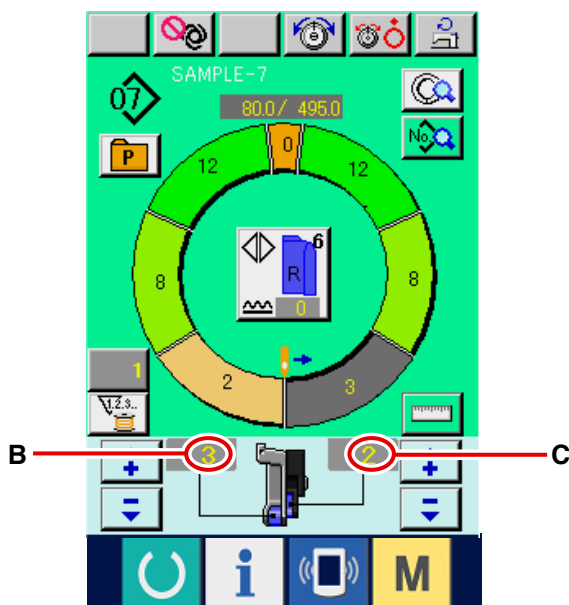

Sewing screen

7-5 Basic operation of the sewing machine

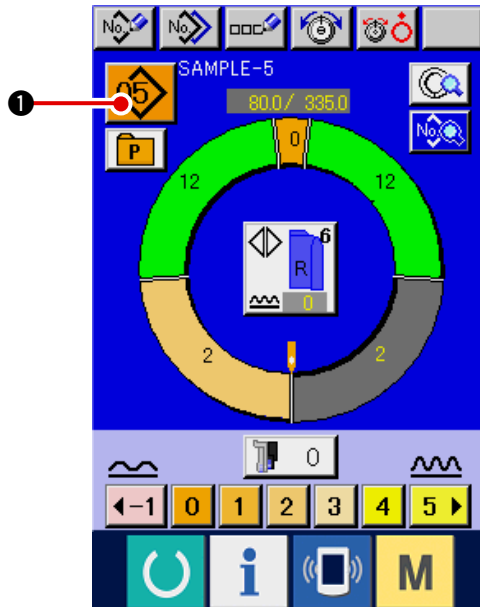

(1) Prepare the materials.

- 1) Prepare left and right sleeves, and garment body.

(2) Turn the power ON.





- 1) Turn the power switch ON.
- 2) Data input screen is displayed after the display of the initial screen.





Auto-lifter does not move until the screen moves to the sewing screen or the new creation screen. After it has worked, it works in all screens. So, be careful.

(3) Calling the pattern <Pattern No. selection>

Two programs (for right sleeve and left sleeve) are entered in one pattern. Further, the respective programs consist of single or plural steps (sewing data between the respective notches are stored).

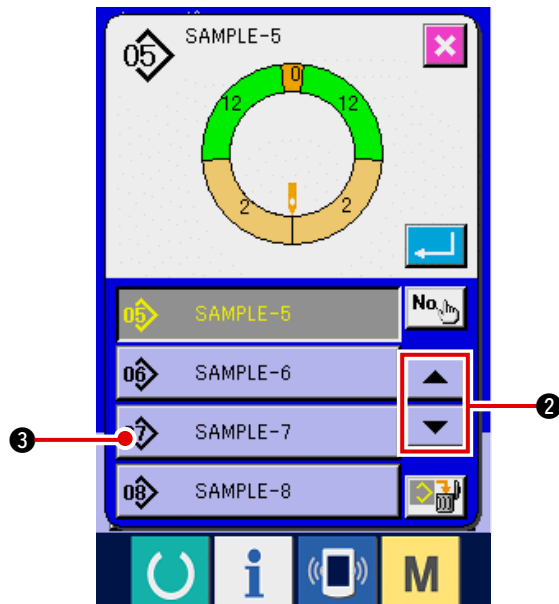
- 1) Press PATTERN SELECTION button  ①.
- 2) Press UP/DOWN SCROLL buttons   ② to display PATTERN No.  SAMPLE-7 button ③ of the pattern to be called.



- 3) Press PATTERN No. button  SAMPLE-7 ③.

- 4) Press ENTER button  ④.

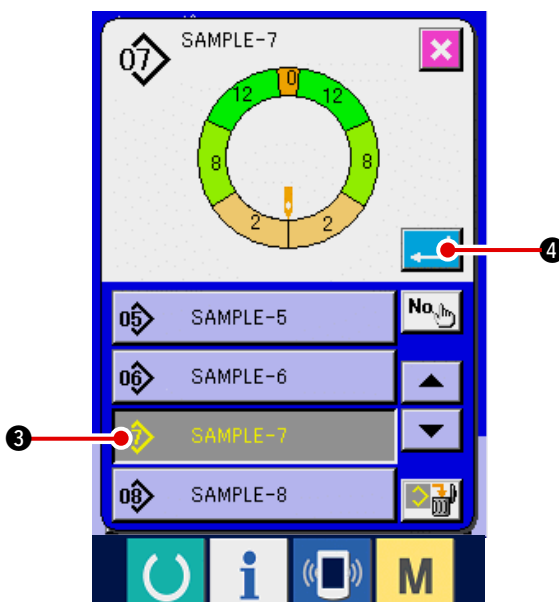

(4) Selecting left/right alternate sewing <Left/right alternate sewing selection>

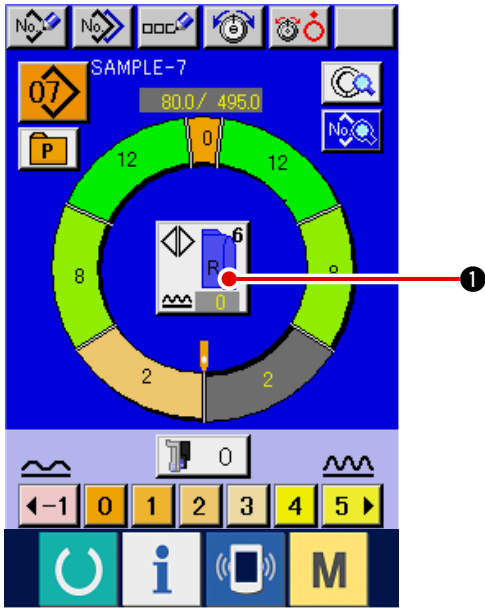

Press LEFT/RIGHT ALTERNATE SEWING button



1 to select program changeover method (for right sleeve and left sleeve).



Alternate sewing, right : Left/right alternate sewing starting from the right sleeve



Alternate sewing, left : Left/right alternate sewing starting from the left sleeve



Right sleeve only : Right sleeve sewing only



Left sleeve only : Left sleeve sewing only

(5) Performing sewing

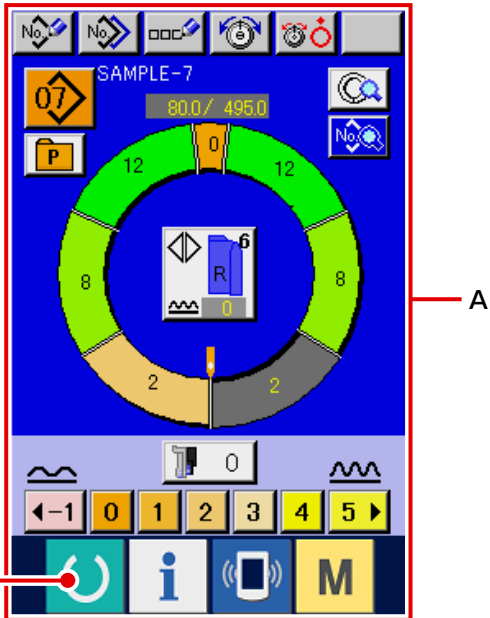

1) Press READY key  2.

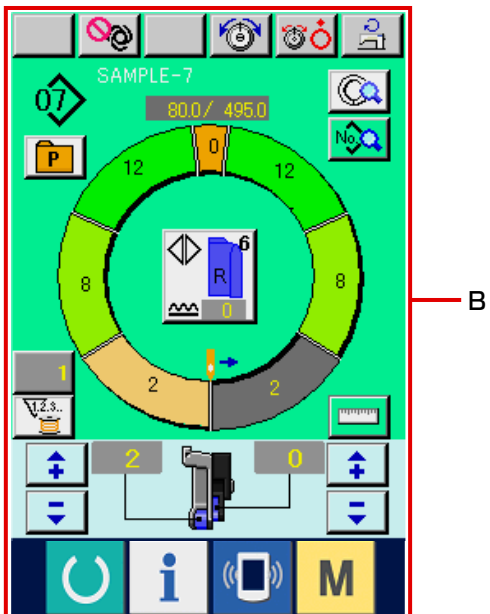

2) Display changes over from data input screen **A** to sewing screen **B**.

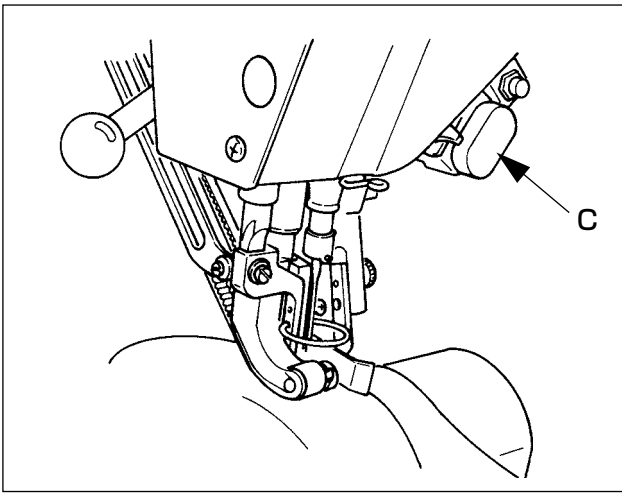

- 3) Set sleeves and garment body to the sewing machine.
- * When temporarily setting the shirring amount to "0" during sewing, press SHIRRING RELEASE switch **C**.
When the switch is pressed, LED lights up and the shirring amount is set to "0". When the switch is pressed twice, LED goes off and the shirring amount returns to the shirring amount of the selected step.

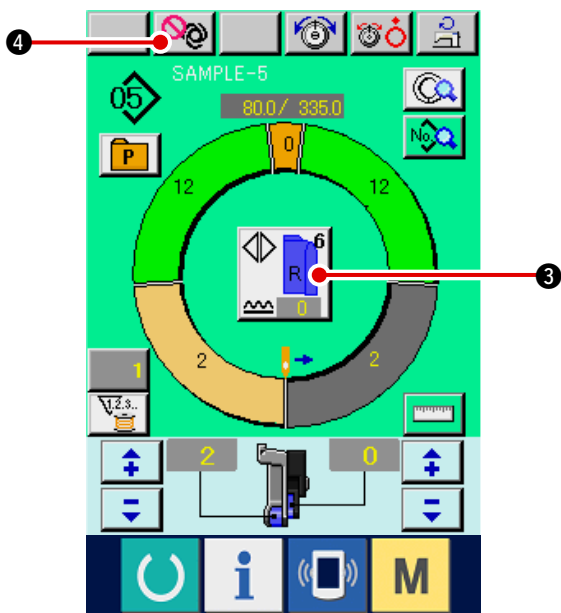

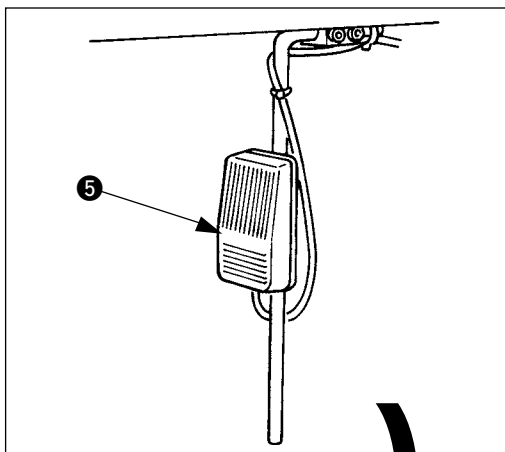

- 4) Check LEFT/RIGHT ALTERNATE button  **3** whether the set materials and the called program (for right sleeve/left sleeve) correspond with each other.
- 5) Start sewing.
- 6) When sewing is performed up to the next notch, the step automatically changes over.

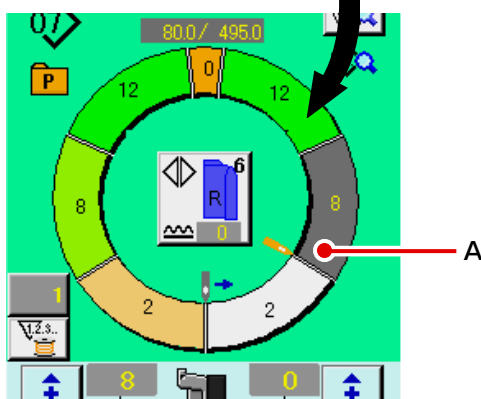

- 7) When the step is not automatically changed over, press knee switch **5** once. Step of the program advances by one (A).
- * When the step is not automatically changed over, perform the register of the length of step. Refer to ["8-4-\(2\) Re-registering the length between steps"](#).



- 8) Repeat procedures 5) through 7) until the end of sewing.
- 9) When temporarily interrupting the fully-automatic during sewing, press FULL AUTO INTERRUPTION button  **4**. Measuring is stopped and the full-auto mode is interrupted. When starting again, press again FULL AUTO INTERRUPTION button  **4**.

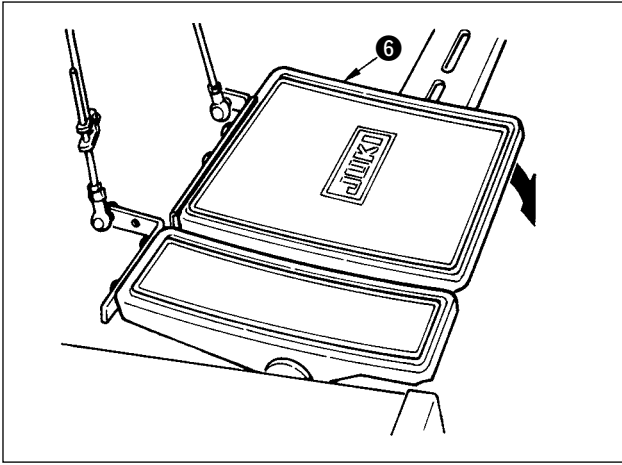

10) Perform thread trimming with pedal ⑥.

7-6 Changing the basic set value

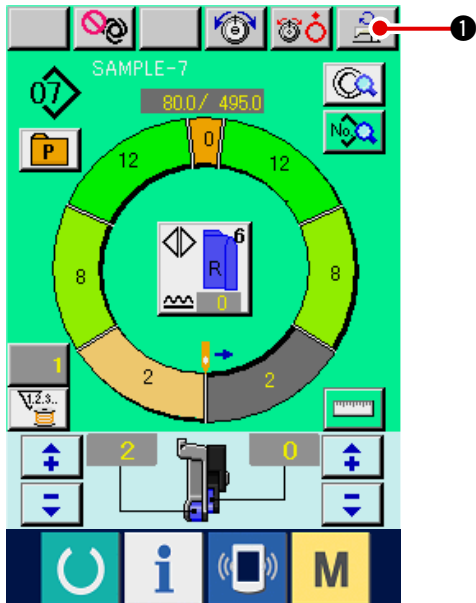

(1) Changing the sewing machine speed <Max. sewing speed setting>

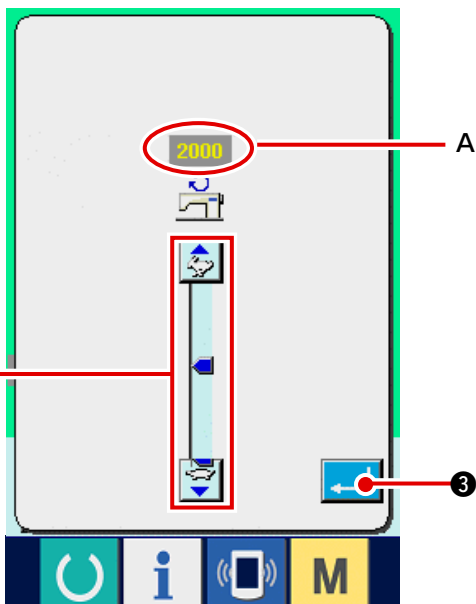

1) Press MAX. SEWING SPEED SETTING button



2) Press MAX. SEWING SPEED CHANGE button

 (fast) and  (slow) ② alternately to change "speed set value" A .

3) Press ENTER button  ③.

(2) Changing the pitch <Pitch setting>

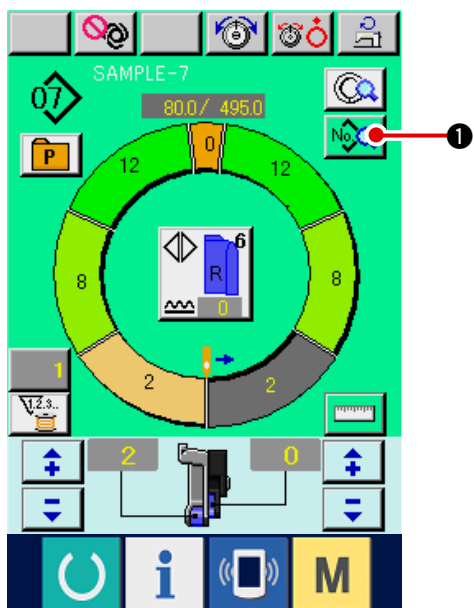



1) Press SEWING DATA DISPLAY button

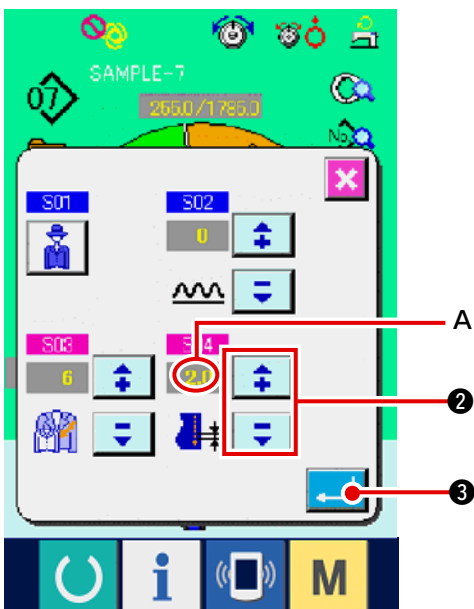

①.



2) Press "+"/ "-" buttons   ② to change pitch set value A.

3) Press ENTER button  ③.

(3) Changing the needle thread tension <Needle thread tension setting>

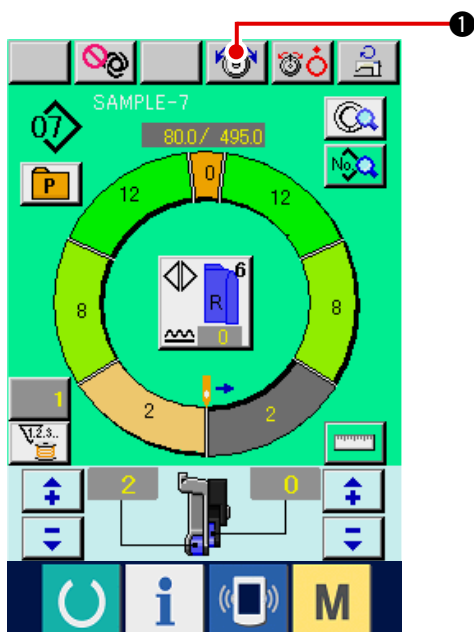

1) Press NEEDLE THREAD TENSION SETTING button  ①.

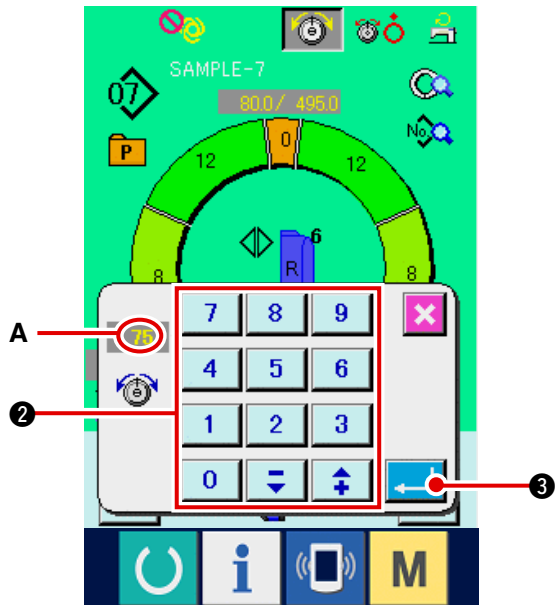

- 2) Press ten keys

7	8	9
4	5	6
1	2	3
0	↓	↑

 ② to change needle thread tension set value **A**.
- 3) Press ENTER button ③.

(4) Changing the shirring amount <Shirring amount setting>

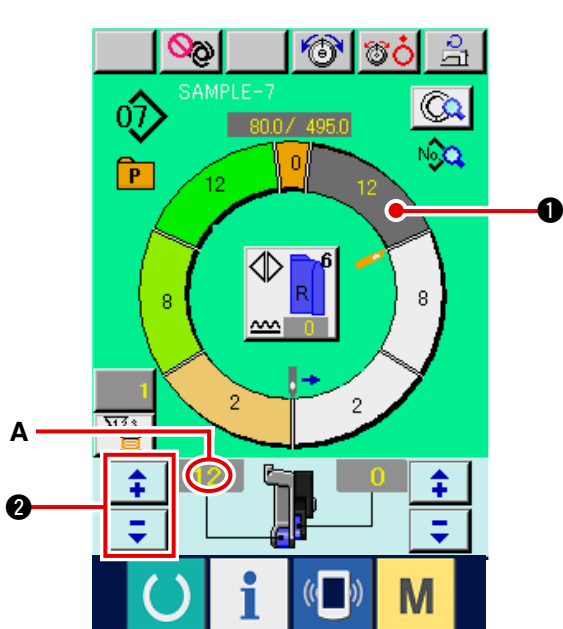

- 1) Press STEP SELECTION button ① to select the step.
- 2) Press "+"/ "-" buttons

↑
↓

 ② to change shirring amount set value **A**.

(5) Changing the shirring amount of auxiliary feed <Auxiliary feed shirring amount setting>

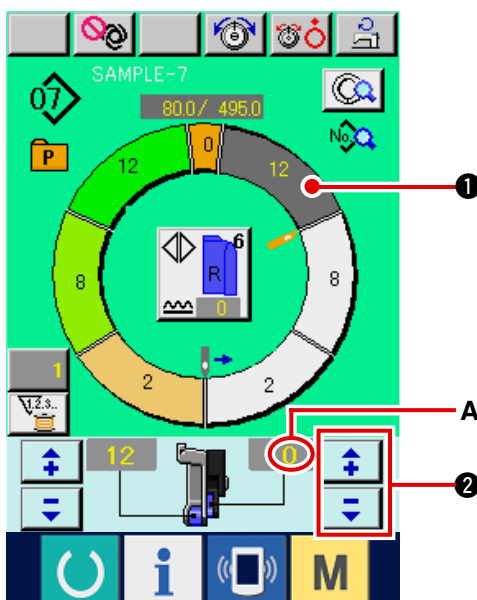

- 1) Press STEP SELECTION button ① to select the step.
- 2) Press "+"/ "-" buttons

↑
↓

 ② to change shirring amount for auxiliary feed set value **A**.



7-7 Creating the pattern <Pattern creation>

The way of correcting the sample pattern and creating the pattern with ease is explained in the basic volume.

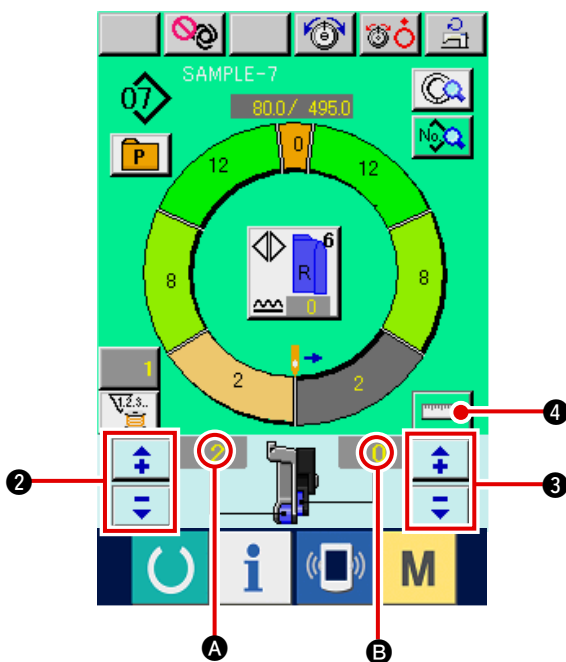

- 1) Prepare the materials.
- 2) Turn the power ON.
- 3) Call a sample pattern where the sewing product and number of steps are the same.
Refer to ["7-5 \(3\) Calling the pattern"](#).
- 4) Change the pitch.
Refer to ["7-6 \(2\) Changing the pitch"](#).
- 5) Select left/right alternate sewing.
Refer to ["7-5 \(4\) Selecting the left/right alternate sewing"](#).
- 6) Press READY key  ①.
- 7) Start sewing.



- 8) Stop the sewing machine at each notch and perform checking of shirring amount.
- 9) When notches do not correspond with each other, press "+" / "-" buttons  ② after thread trimming on the way to change shirring amount set value A, and perform re-sewing.
Refer to ["7-6 \(4\) Changing the shirring amount"](#).
- 10) When the sleeve material on the outlet seam side delays, press "+" / "-" buttons  ③ after thread trimming on the way to change shirring amount for auxiliary feed set value B, and perform re-sewing.
Refer to ["7-6 \(5\) Changing the shirring amount of auxiliary feed"](#).
- 11) When the program of one sleeve is completed, sew the other sleeve and correct the program.
- 12) When the program is completed, press MEASURE button  ④.
- 13) Start sewing.
- 14) When sewing is performed up to the next notch, stop the sewing machine once.

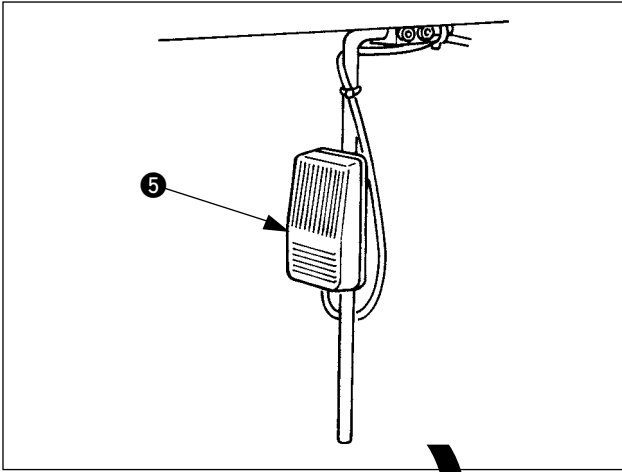

15) Press knee switch **5** once. Step of the program advances by one. **(A)**

16) Repeat procedures 13) through 15) until the end of sewing.

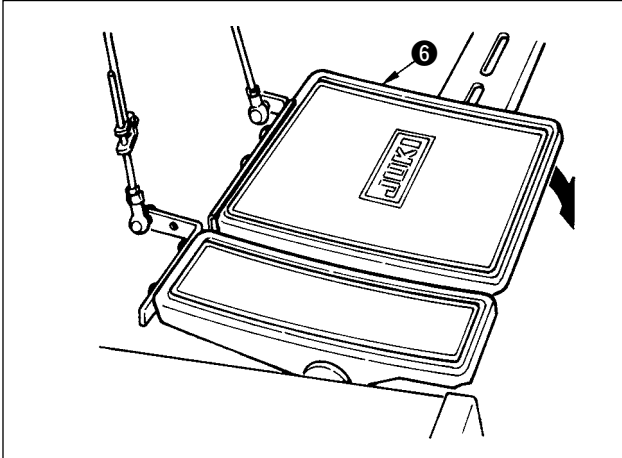
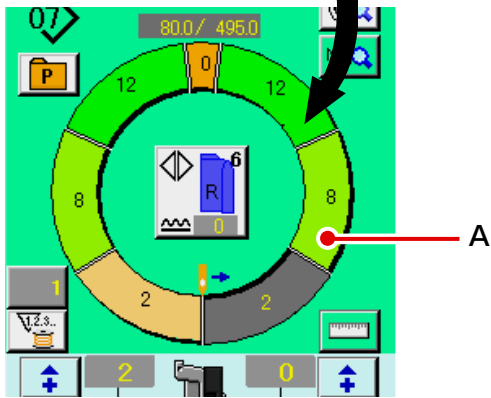

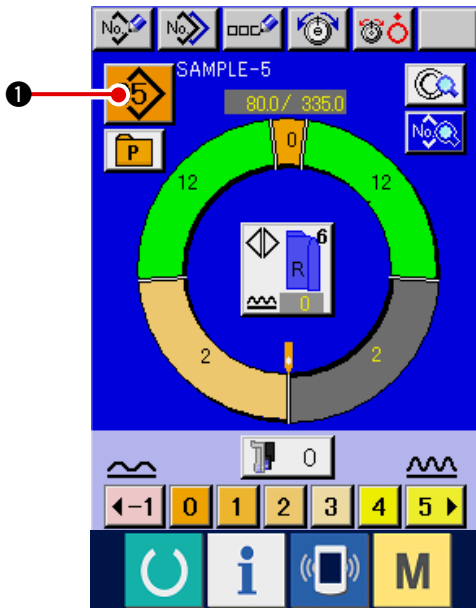

17) Perform thread trimming with pedal **6**.

7-8 Deleting the pattern <Pattern deletion>



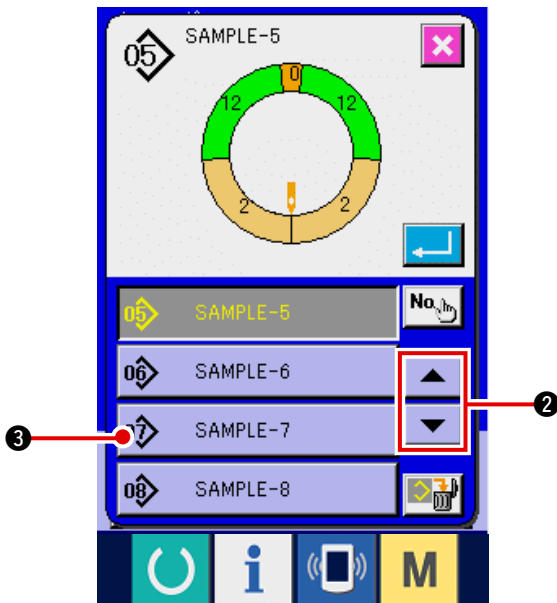

1) Press PATTERN SELECTION button  ①.

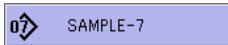

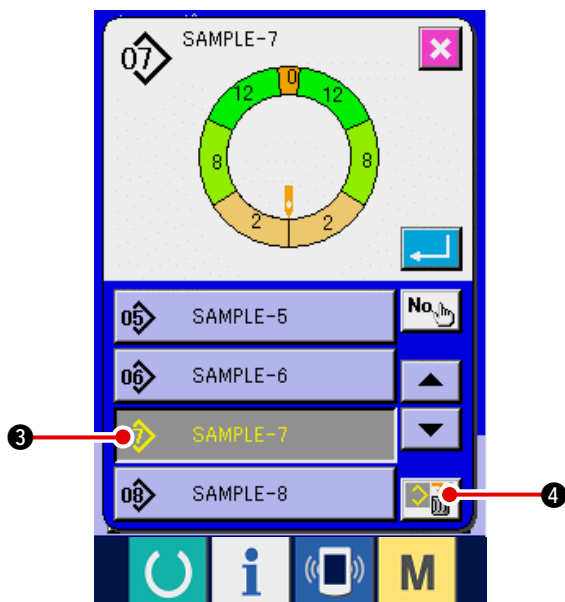
2) Press UP/DOWN SCROLL button 
 ② to display PATTERN No. button
 SAMPLE-7 ③ to be deleted.

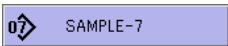

3) Press PATTERN No. button  SAMPLE-7
 ③.
 4) Press PATTERN DELETION button  ④.

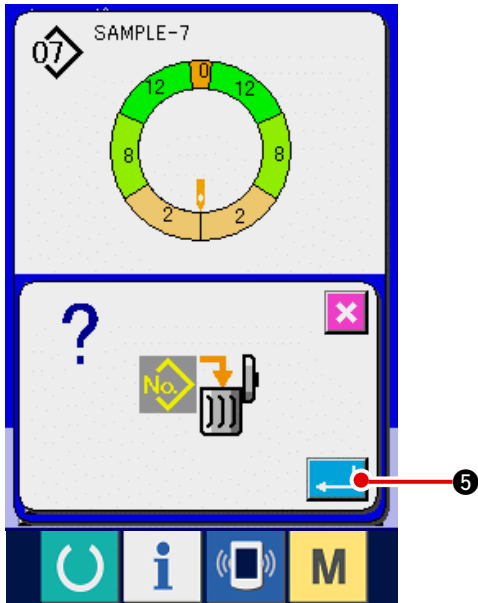

5) Press ENTER button  5.

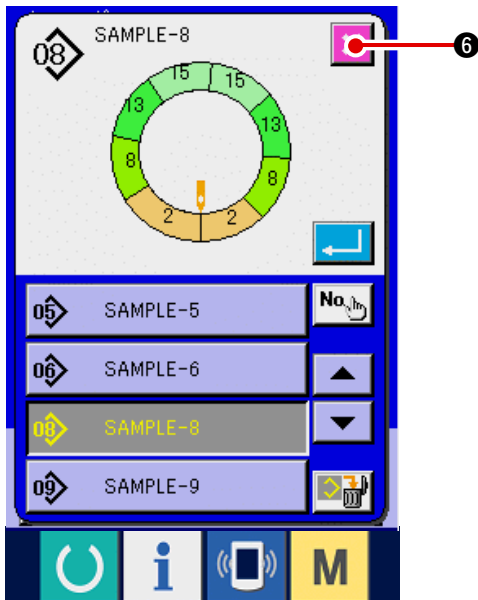

6) Press CANCEL button  6.

8. OPERATION OF THE SEWING MACHINE (FULLY-AUTOMATIC APPLICATION VOLUME)

8-1 Correcting the pattern

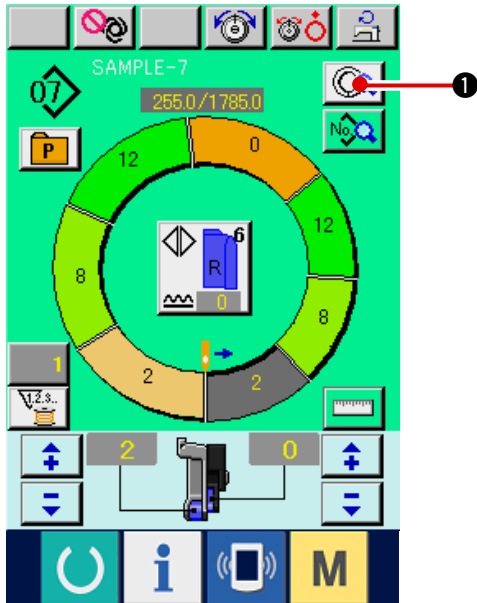

(1) Changing the length of specified step <Length between steps setting>

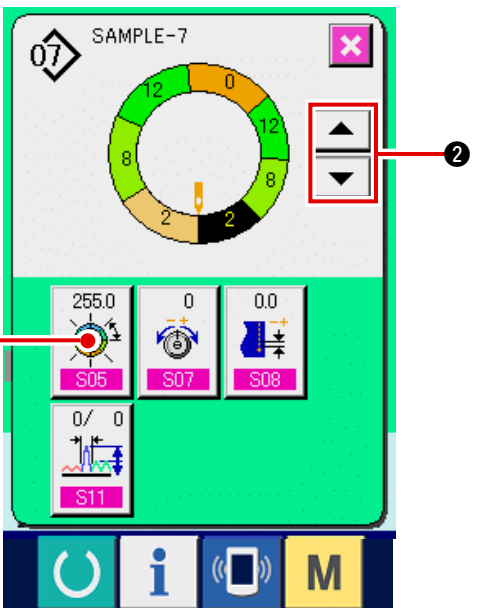

* The state that can be changed in the sewing screen is the state that step 1 is selected before starting sewing.

- 1) In the state that step 1 is selected, press STEP DETAILS button  ①.



- 2) Press STEP FEED/RETURN buttons   ② to select the step to be changed.

- 3) Press LENGTH BETWEEN STEPS SETTING button  ③.

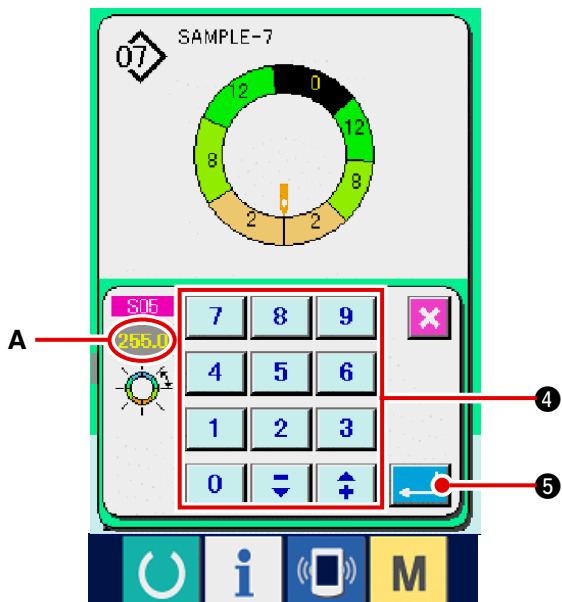

- 4) Press ten keys

7	8	9
4	5	6
1	2	3
0	↓	↑

 ④ to change length between steps **A**.

- 5) Press ENTER button  ⑤.

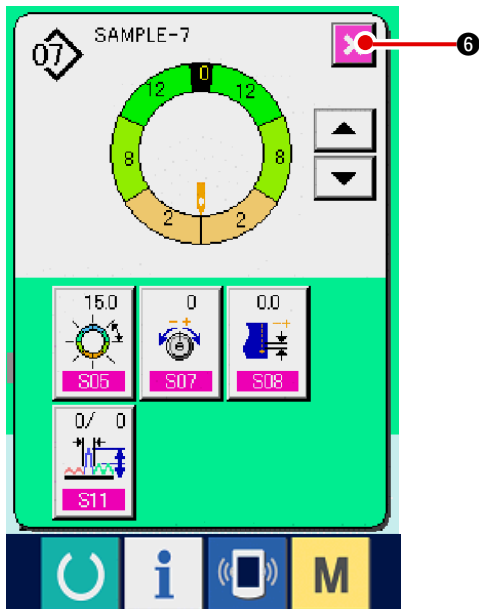

6) Press CANCEL button  6.

(2) Changing the needle thread tension of specified step
<Compensation thread tension setting>

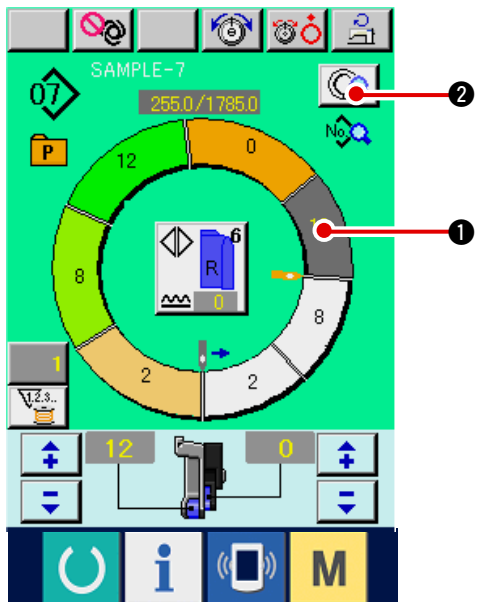

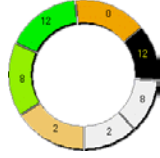
1) Press STEP SELECTION button 

1 to select the step.

2) Press STEP DETAILS button  2.

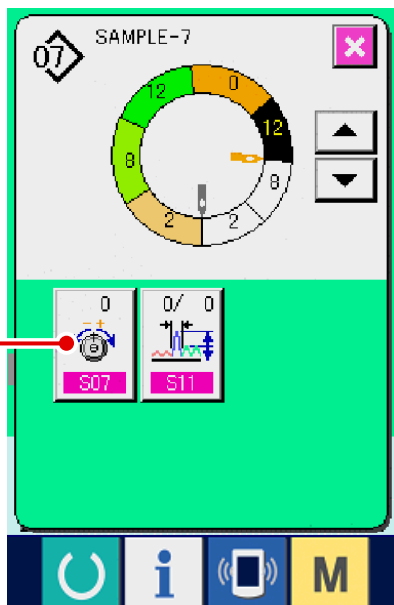

3) Press COMPENSATION THREAD TENSION

SETTING button  3.

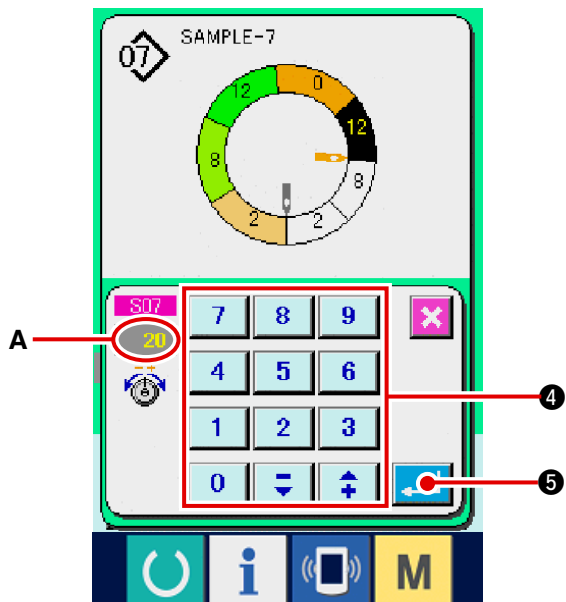



4) Press ten keys

7	8	9
4	5	6
1	2	3
0	↓	↑

 ④ to change compensation thread tension set value **A**.

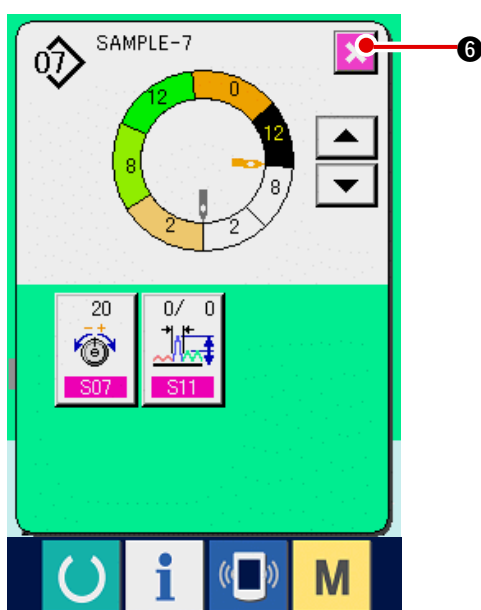
5) Press ENTER button  ⑤.



6) Press CANCEL button  ⑥.

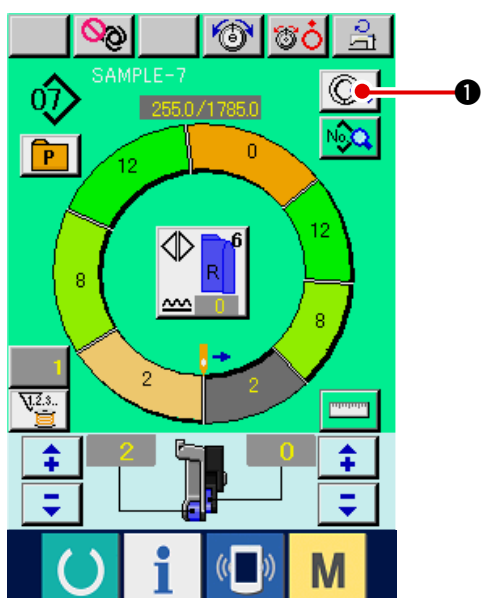

(3) Changing the pitch of specified step <Compensation pitch setting>

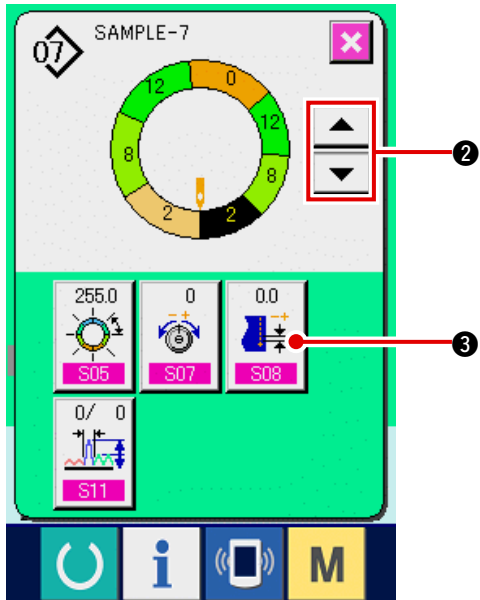

* The state that can be changed in the sewing screen is the state that step 1 is selected before starting sewing.

1) In the state that step 1 is selected, press STEP DETAILS button  ①.



- 2) Press STEP FEED/RETURN buttons   ② to select the step to be changed.
- 3) Press COMPENSATION PITCH button  ③.

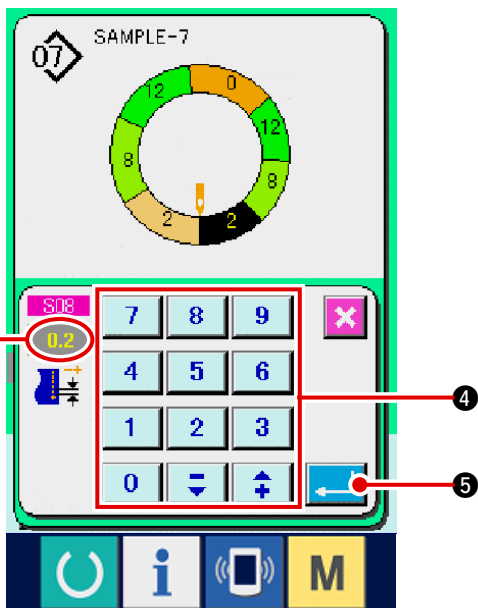

- 4) Press ten keys

7	8	9
4	5	6
1	2	3
0	↓	↑

 ④ to change compensation pitch set value **A**.
- 5) Press ENTER button  ⑤.

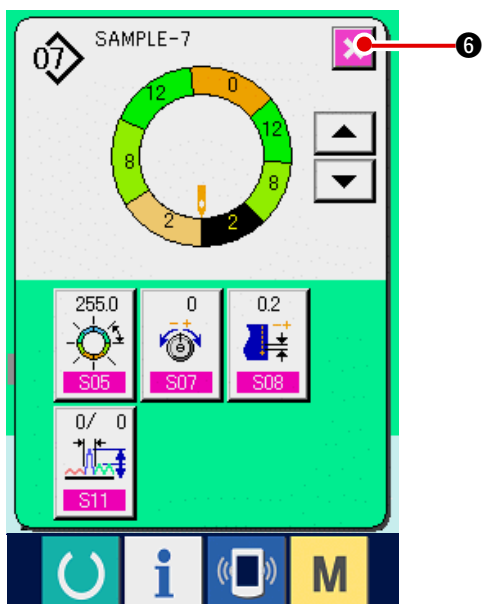

- 6) Press CANCEL button  ⑥.

(4) Increasing/decreasing the shirring amount of all steps

<Shirring amount increase/decrease setting>

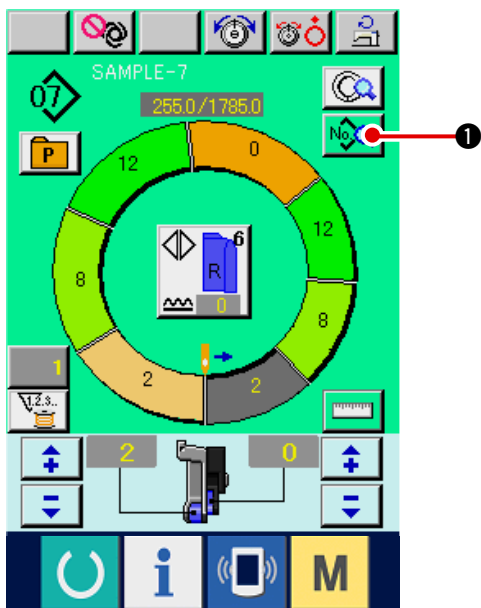

1) Press SEWING DATA DISPLAY button  ①.

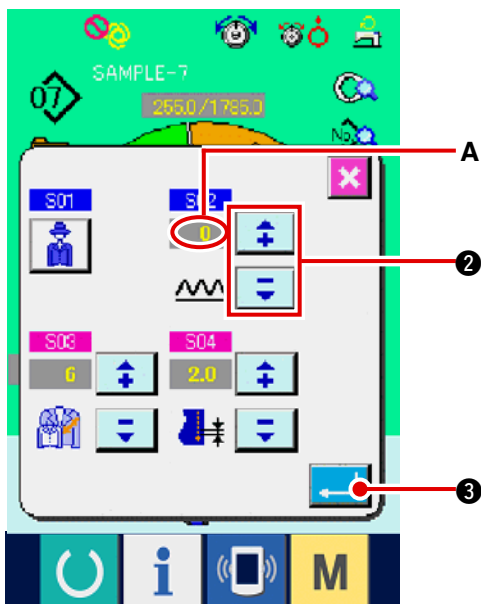

2) Press "+"/ "-" buttons  ② to change pitch set value **A**.

3) Press ENTER button  ③.

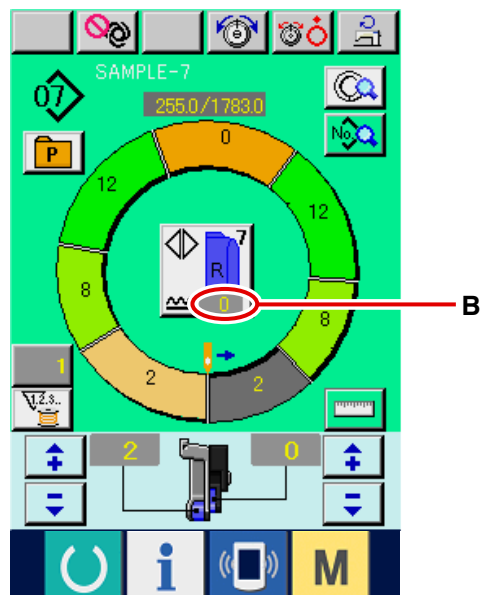

4) Check set value **B**.

(5) Increasing/decreasing the shirring amount immediately after changeover of step
 <Compensation shirring amount setting>

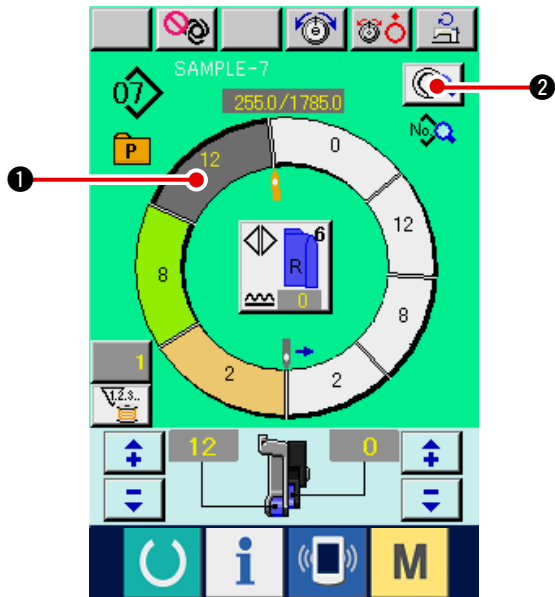

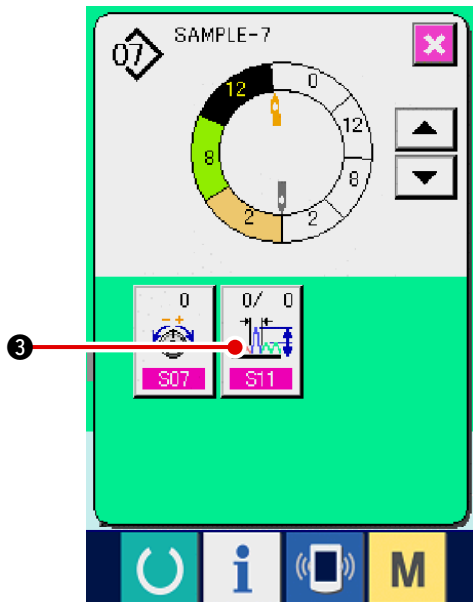

1) Press STEP SELECTION button  ① to select the step.

2) Press STEP DETAILS button  ②.

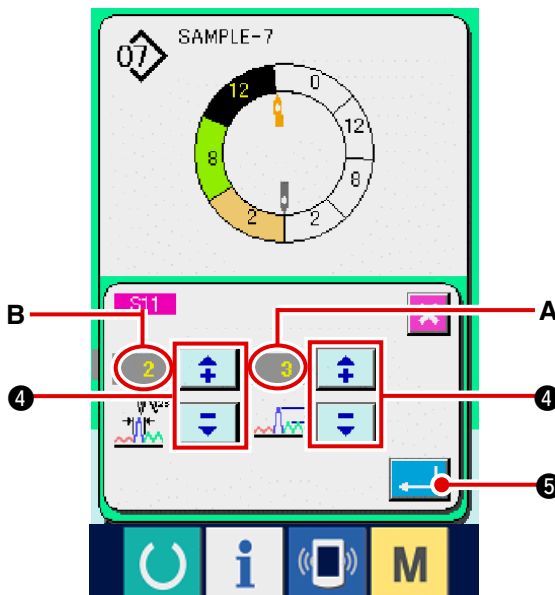

3) Press COMPENSATION SHIRRING AMOUNT SETTING button  ③.



4) Press "+"/ "-" buttons   ④ to change compensation shirring amount set value **A** and number of stitches of compensation shirring amount **B**.

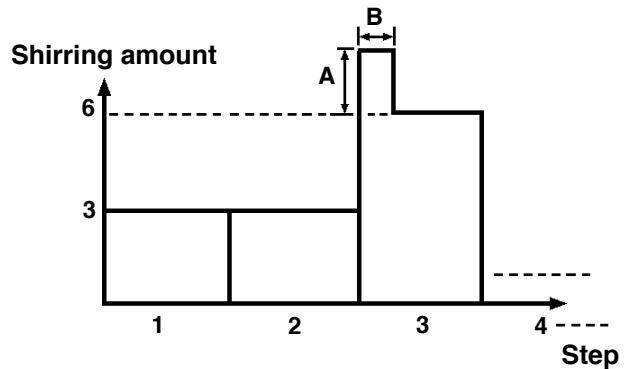

- Compensation shirring amount is the shirring amount to add to the shirring amount of the step after changeover at the time of step changeover.
- Number of stitches of shirring amount compensation is the number of stitches of the section of number of stitches to add the compensation shirring amount from the step changeover.

5) Press ENTER button  ⑤.

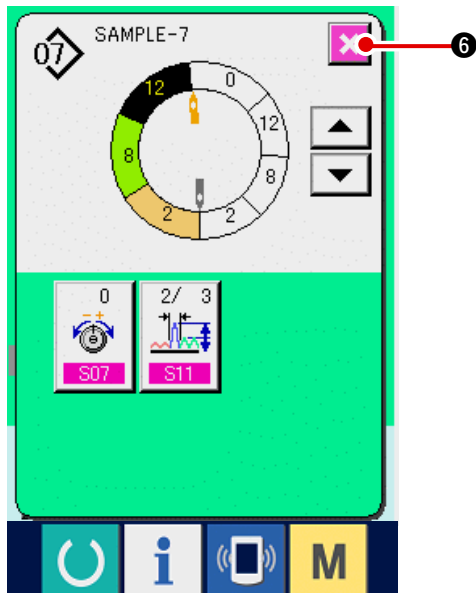

6) Press CANCEL button  6.

(6) Adding the step <Step addition>

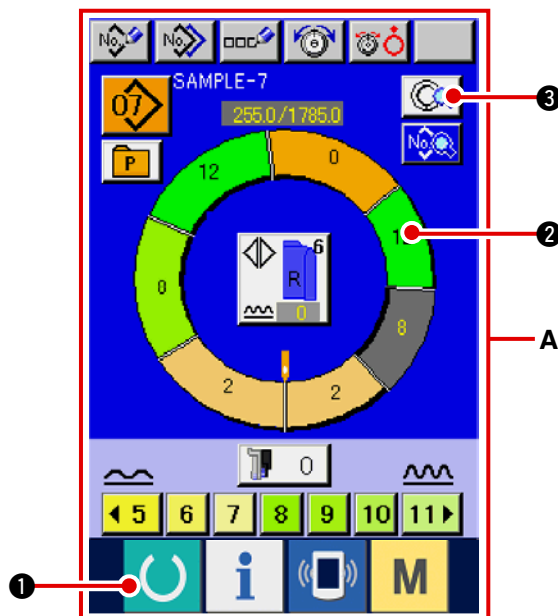

1) Press READY key  1 to change over the screen to data input screen A.

2) Press STEP SELECTION button  2 to select the step which is one before the step addition position.

3) Press STEP DETAILS button  3.

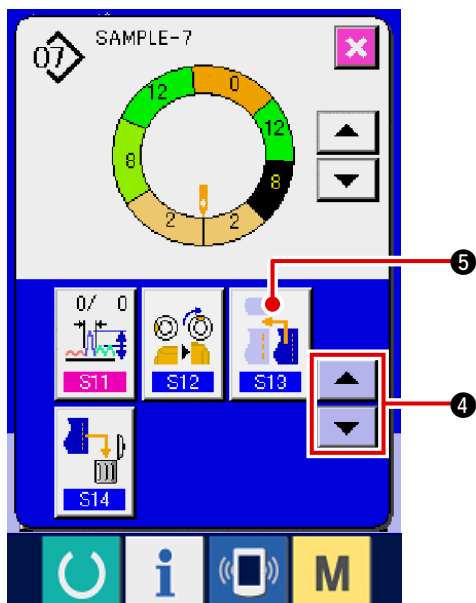

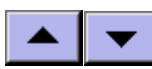

4) Change over the display with SCROLL buttons  4 and press STEP ADDITION

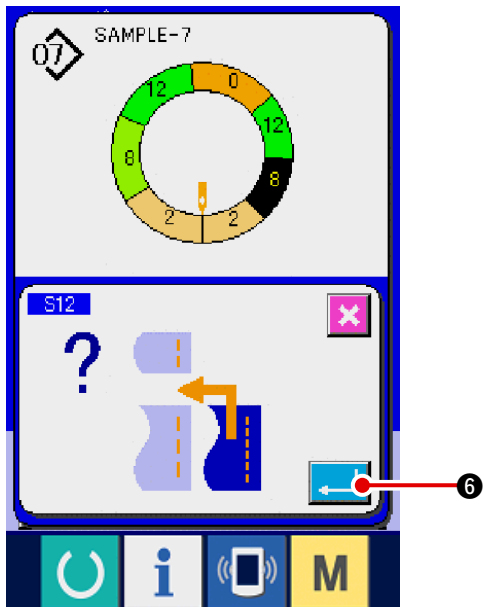
button  5.

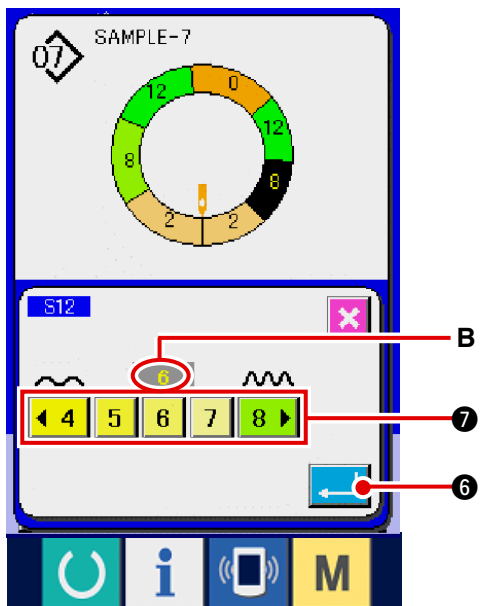

5) Press ENTER button  ⑥.



6) Press SHIRRING AMOUNT buttons
 ⑦ to change shirring amount set value **B**.

7) Press ENTER button  ⑥.

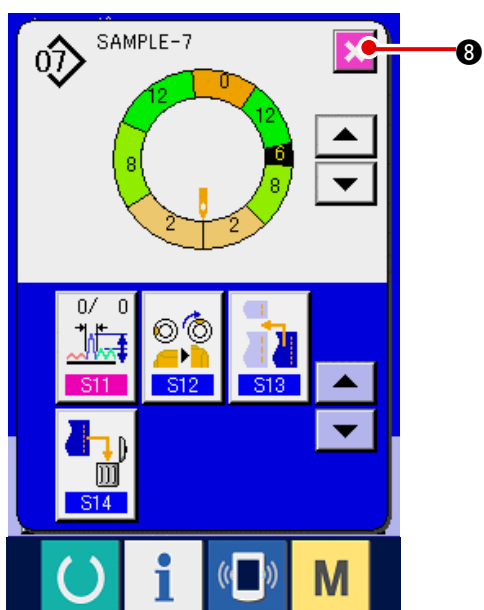

8) Press CANCEL button  ⑧.

(7) Deleting the step <Step deletion>

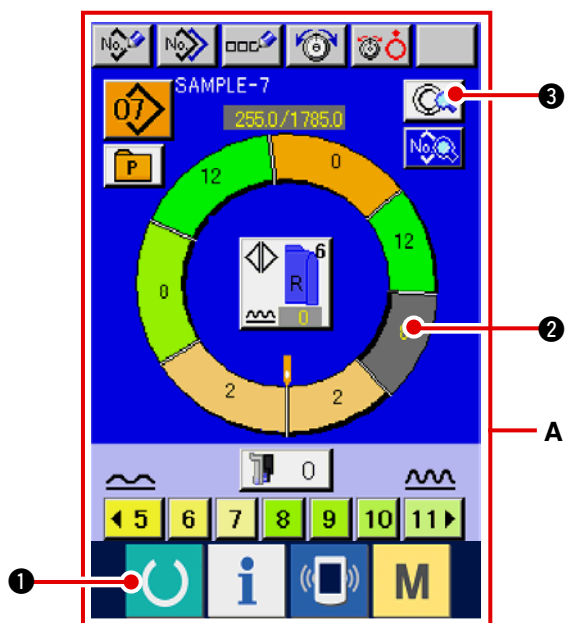

1) Press READY key  ① to change over the screen to data input screen A.

2) Press STEP SELECTION button



② to select the step to be deleted.

3) Press STEP DETAILS button  ③.

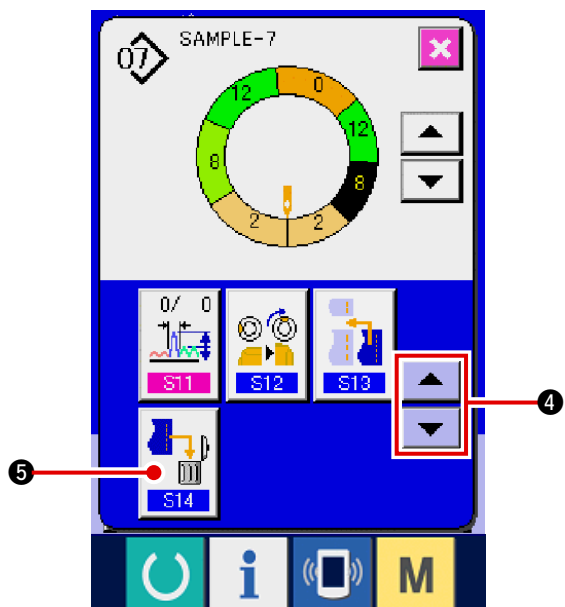

4) Change over the display with SCROLL buttons





④

and press STEP DELETION button

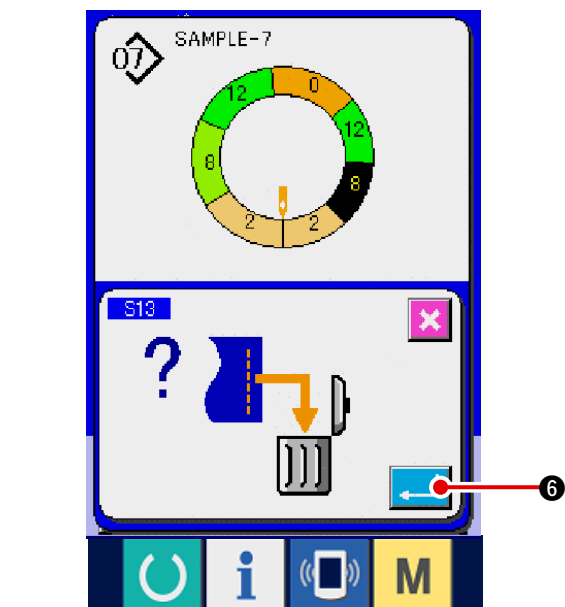

⑤.



5) Press ENTER button  ⑥.

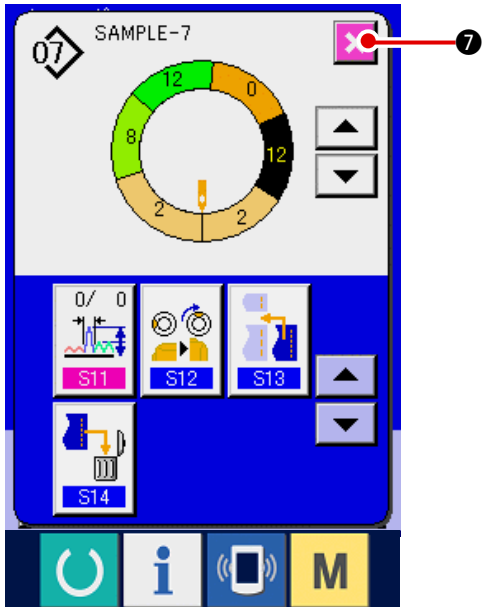

6) Press CANCEL button  7.

(8) Changing gent's/ladies' wear classification <Gent's/ladies' selection>

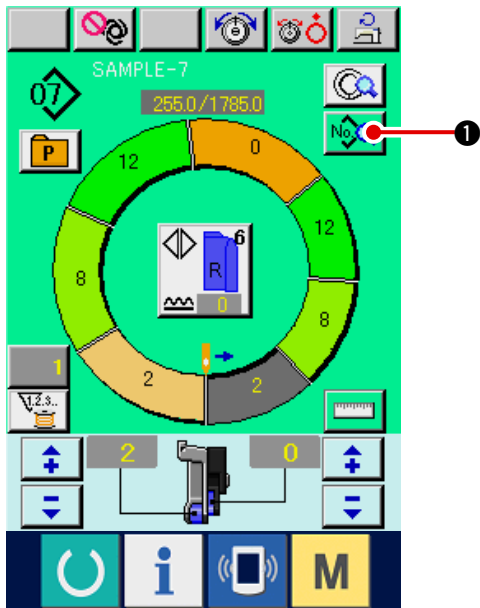

1) Press SEWING DATA DISPLAY button  ①.

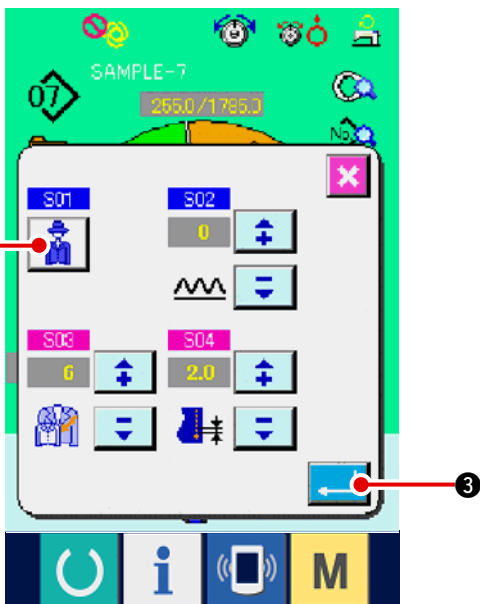

2) Press GENT'S/LADIES' SELECTION button

 ② to change the selection.

3) Press ENTER button  ③.

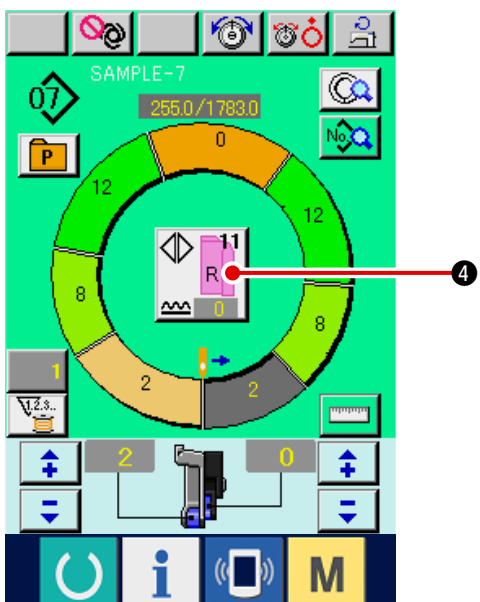

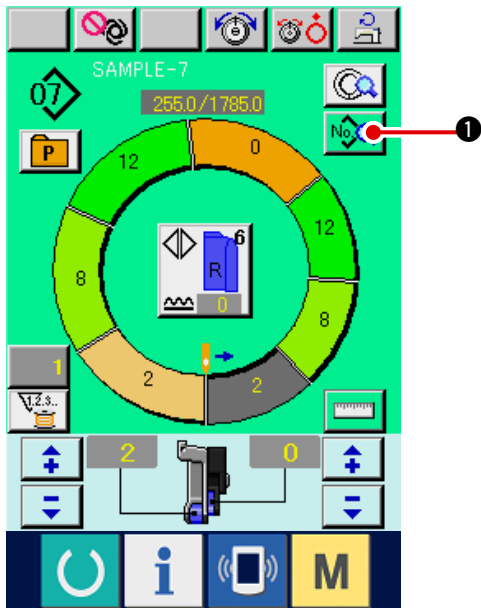

4) Check the contents ④.

(9) Changing the size <Size change>

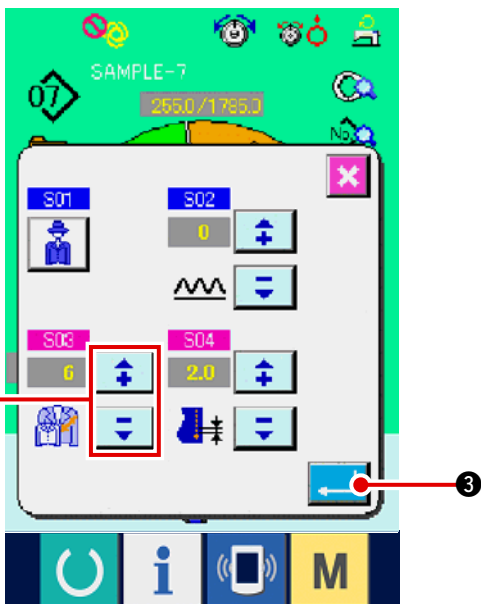

1) Press SEWING DATA DISPLAY button  ①.



2) Press "+"/ "-" buttons  ② to change the size.

3) Press ENTER button  ③.

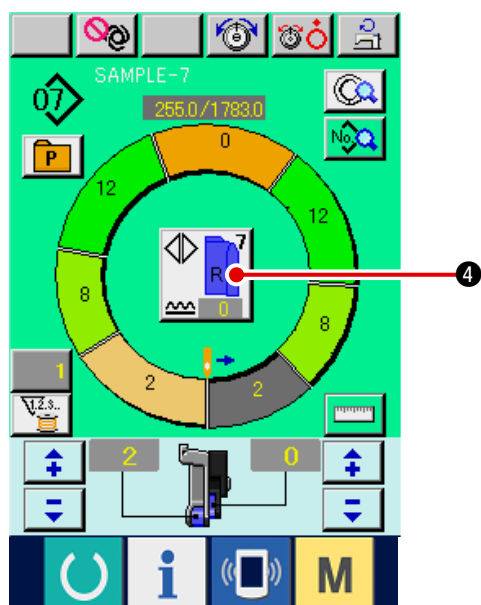

4) Check set value ④.

(10) Setting the offset value of grading <Grading value setting>

Grading is the way to enlarge or reduce the basic pattern and develop the size. Here, increased or decreased value per size when the size is changed can be set at every step.

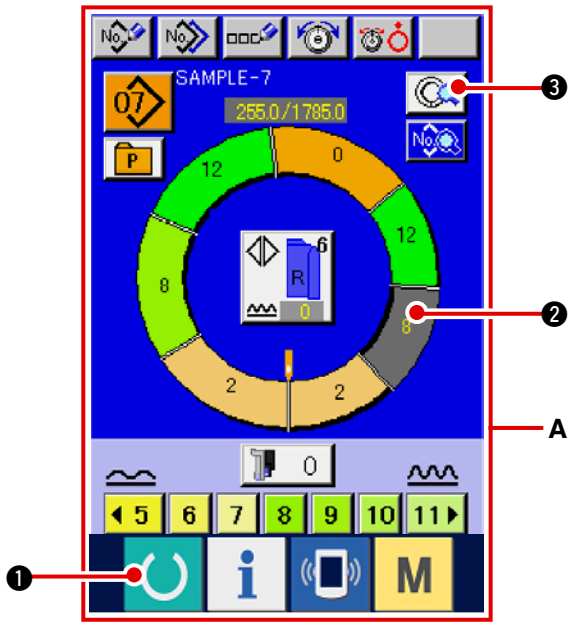

1) Press READY key  ① to change over the screen to data input screen A.

2) Press STEP SELECTION button 

② to select the step you desire to set.

3) Press STEP DETAILS button  ③.

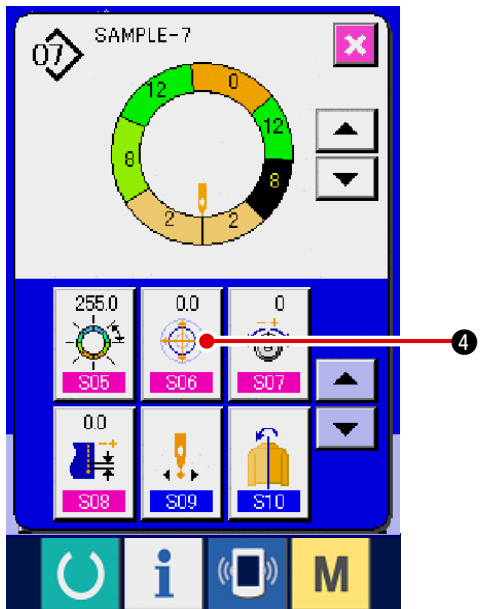

4) Press GRADING VALUE SETTING CHANGE

button  ④ .

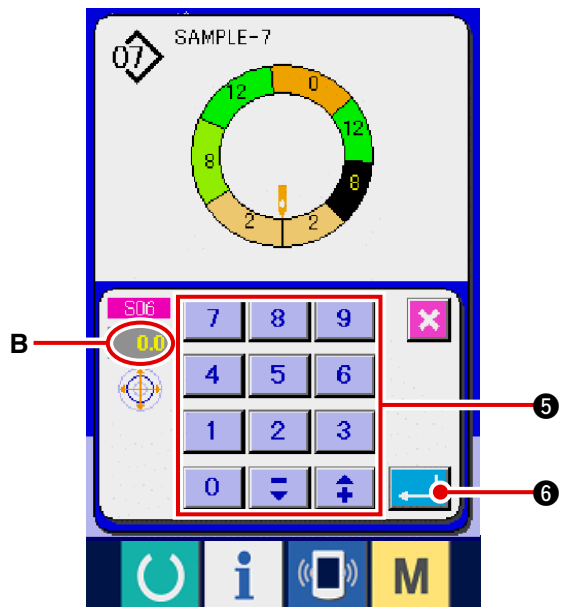

5) Press ten keys  ⑤ to change grading

value B.

6) Press ENTER button  ⑥.

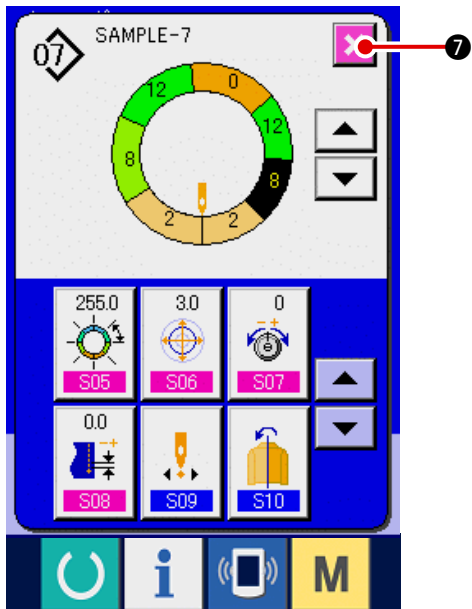

7) Press CANCEL button  7.

(11) Changing the start position of program <Start position change>

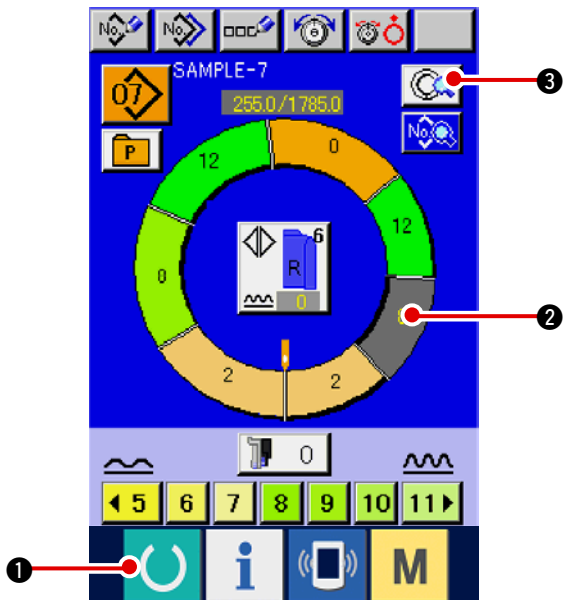

1) Press READY key  1 to change over the screen to data input screen.

2) Press STEP SELECTION button



2 to select the step you desire to set the start position.

3) Press STEP DETAILS button  3.

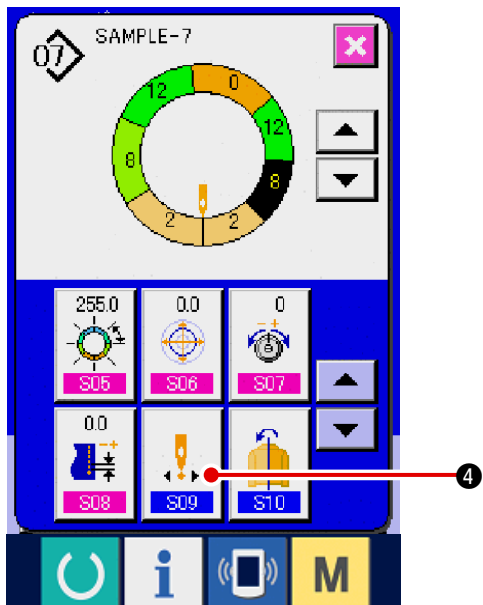

4) Press START POSITION CHANGE button



4.

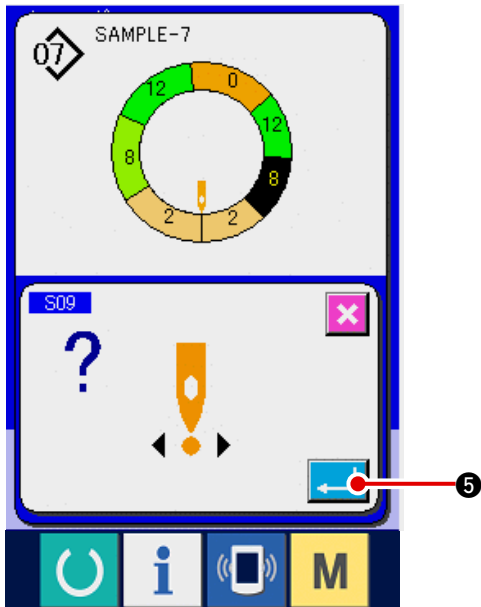

5) Press ENTER button  ⑤.

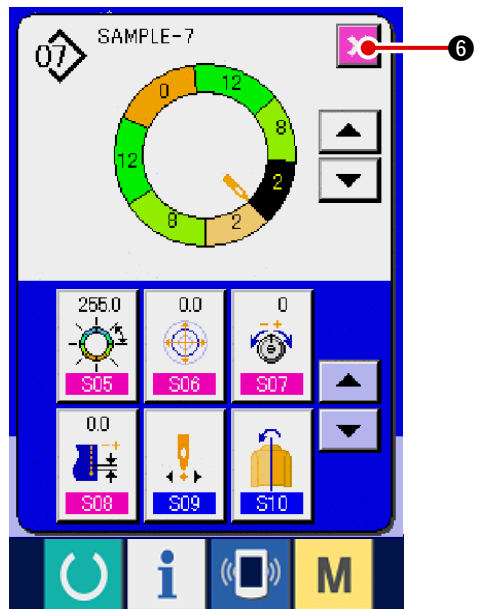

6) Press CANCEL button  ⑥.

* When the start position is changed, simultaneously the shirring amount data of each step move together.

(12) Mirroring the program of one sleeve and creating the program of the other one <Mirroring function>

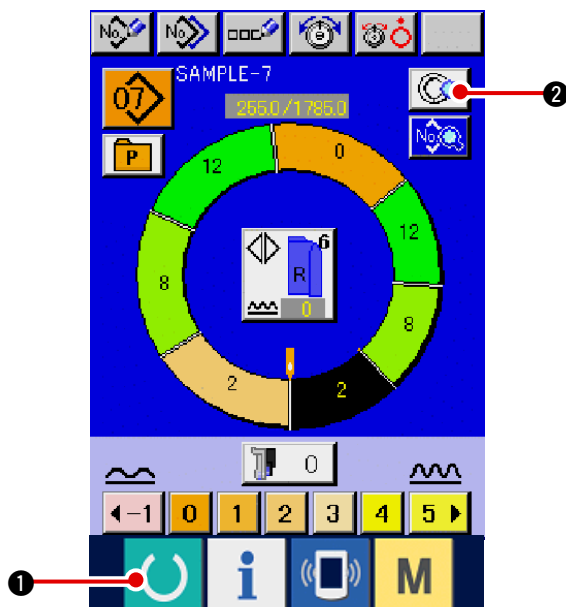

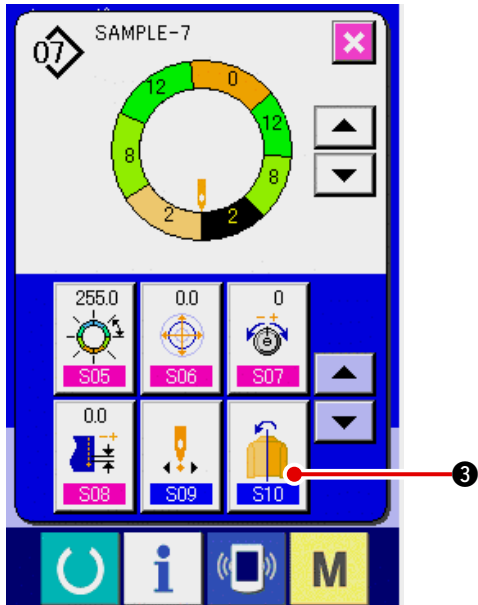

1) Press READY key  ① to change over the screen to data input screen.

2) Press STEP DETAILS button  ②.

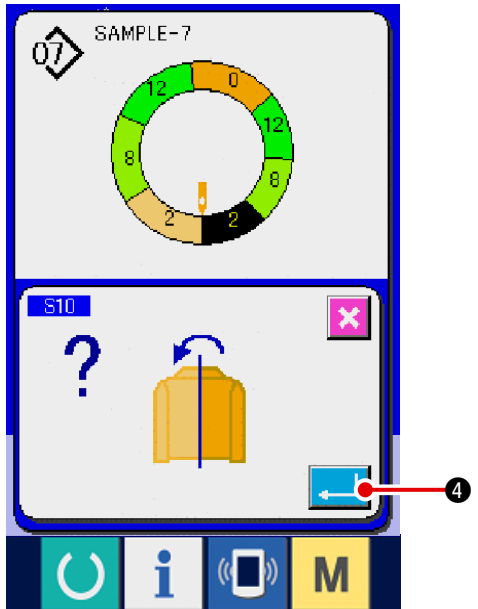

3) Press MIRRORING button  ③.



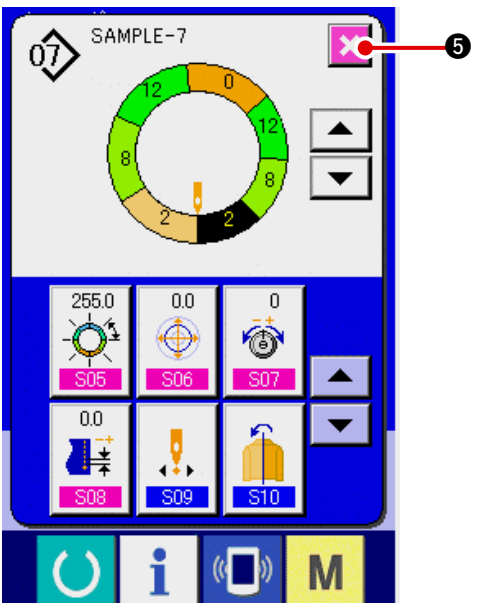

4) Press ENTER button  ④.

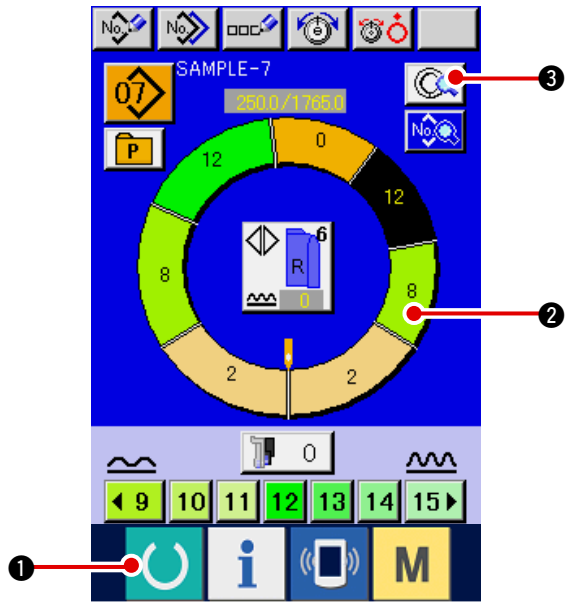

5) Press CANCEL button  ⑤.

(13) Changing the top notch position of program <Top notch position change>



1) Press READY key  ① to change over the screen to data input screen.

2) Press STEP SELECTION button  ② to select the step you desire to set the top notch position.

3) Press STEP DETAILS button  ③.

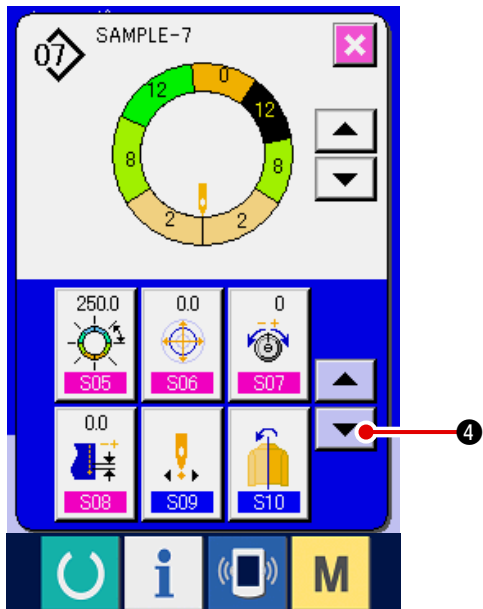

4) Press DOWN SCROLL button  ④.

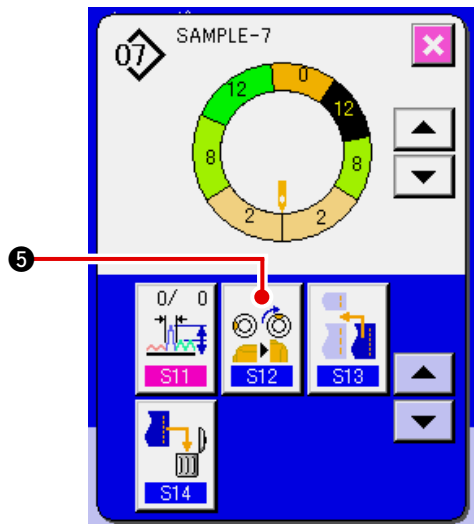

5) Press TOP NOTCH POSITION CHANGE button  ⑤.

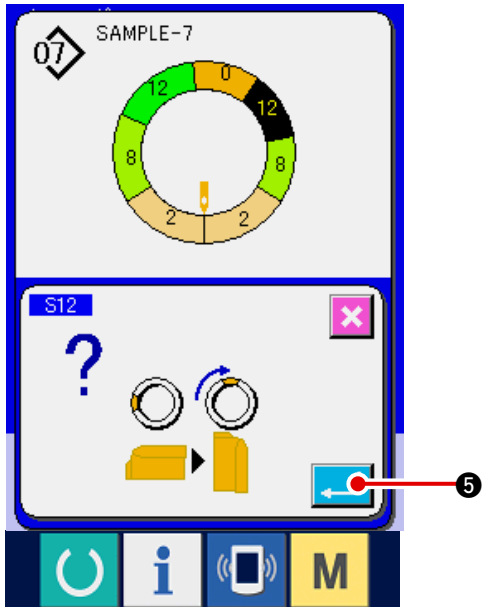

6) Press ENTER button  ⑤.

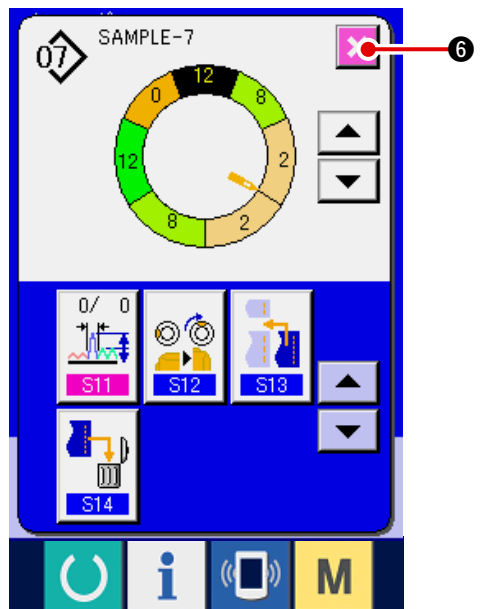

7) Press CANCEL button  ⑥.

(14) Naming the pattern <Data name setting>

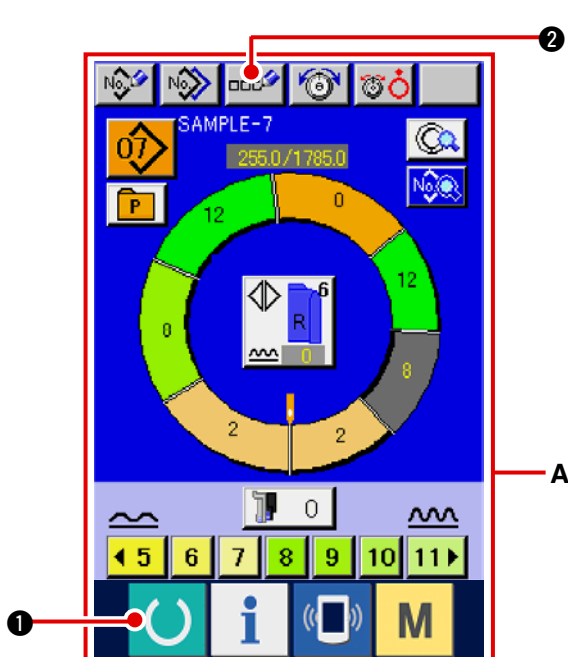

1) Press READY key  ① to change over the screen to data input screen **A**.

2) Press LETTER INPUT button  ②.

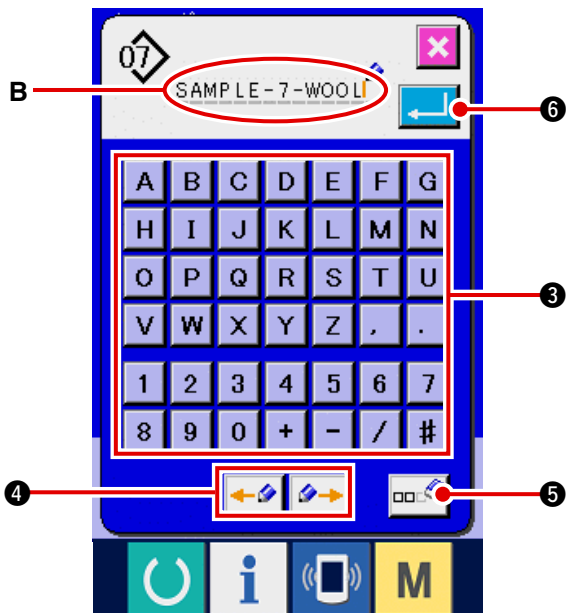

3) Press LETTER button  ③ to input

A	B	C	D	E	F	G
H	I	J	K	L	M	N
O	P	Q	R	S	T	U
V	W	X	Y	Z	.	,
1	2	3	4	5	6	7
8	9	0	+	-	/	#

the letter.

4) Cursor inside input letter display **B** can be moved with CURSOR, LEFT (RIGHT) MOVE

button  () ④.

5) When DELETION button  ⑤ is pressed, the letter on the left side of cursor disappears.

6) Press ENTER button  ⑥.

7) The inputted letter is displayed at pattern name display section **C**.

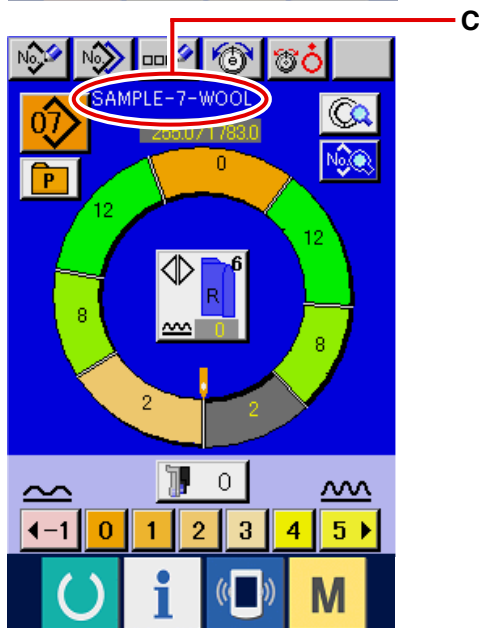

8-2 Copying the pattern <Pattern copy>

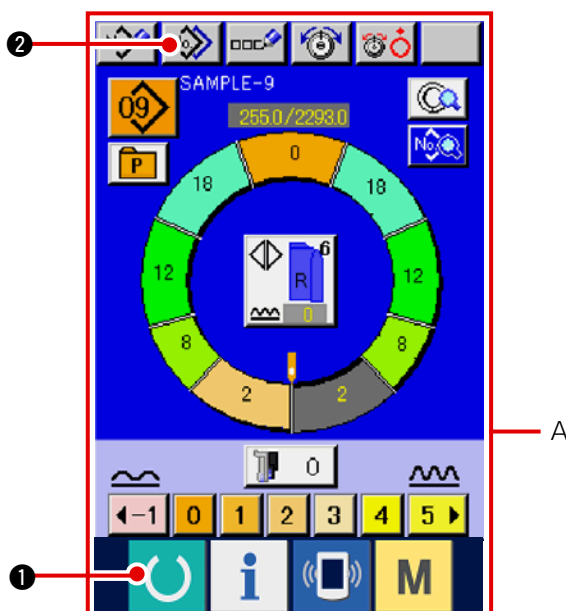

(1) Pattern copy in the fully-automatic <Copy to fully-automatic>

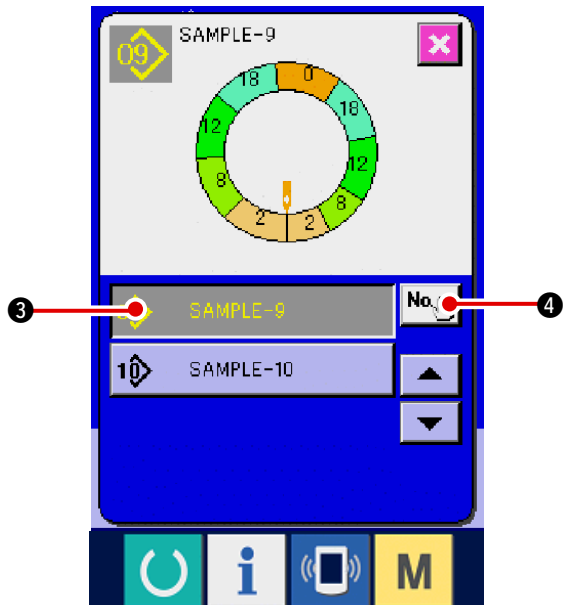

1) Press READY key  ① to change over the screen to data input screen **A**.

2) Press PATTERN COPY button  ②.



- 3) Press PATTERN No. button  **3** to select the pattern of copy source.
- 4) Press COPY DESTINATION INPUT button  **4**.

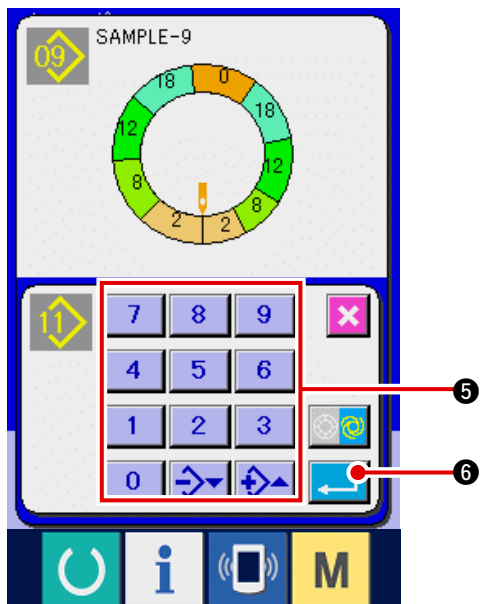

- 5) Press ten keys

7	8	9
4	5	6
1	2	3
0	↔	↔

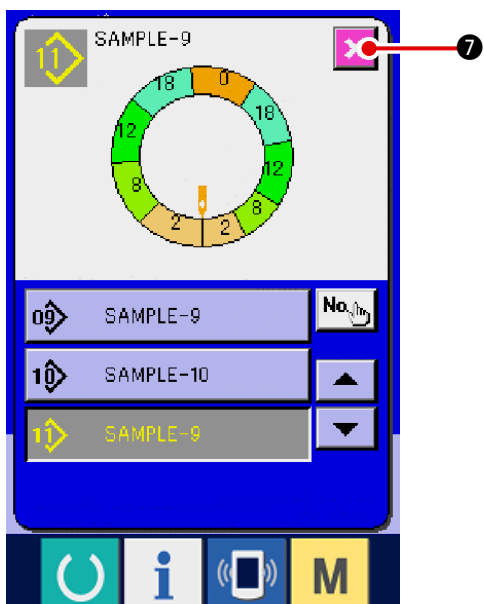

5 to input the pattern No. of copy destination.
- 6) Press ENTER button  **6**.



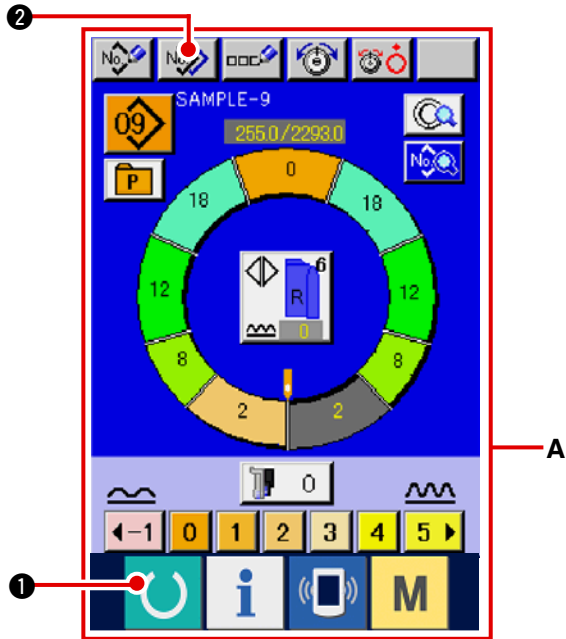

- 7) Press CANCEL button  **7**.
- * When the number of registered patterns of fully-automatic is 99 patterns, the display is automatically changed over and the pattern is copied to semi-automatic.

(2) Pattern copy from fully-automatic to semi-automatic <Copy to semi-automatic>



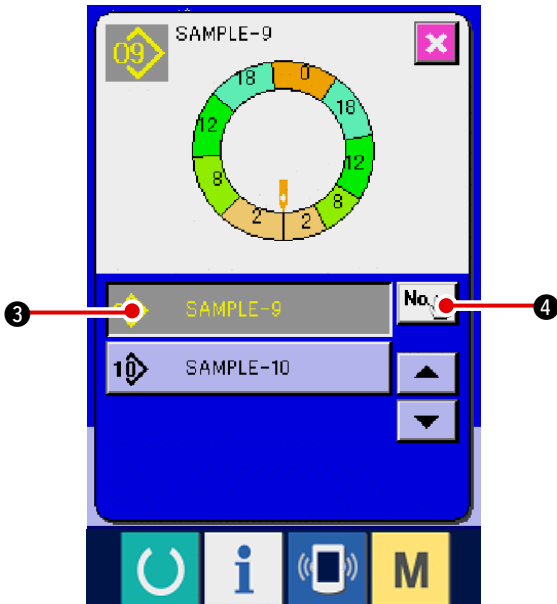

- 1) Press READY key  ① to change over the screen to data input screen A.
- 2) Press PATTERN COPY button  ②.

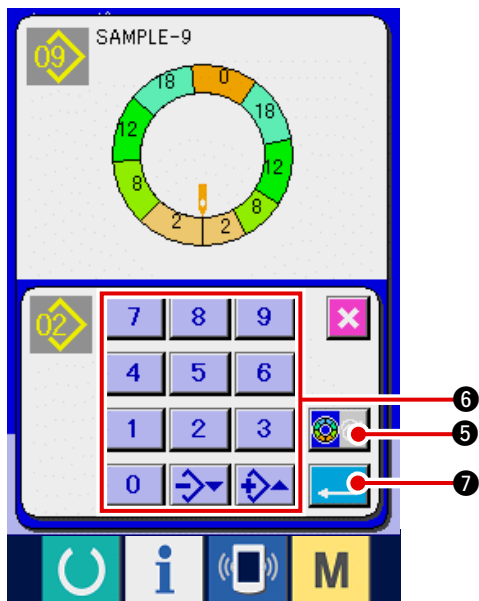

- 3) Press PATTERN No. button  ③ to select the pattern of copy source.
- 4) Press COPY DESTINATION INPUT button  ④.



- 5) Press SEMI AUTO/FULL AUTO CHANGE OVER button  ⑤ to display SEMI AUTO .
- 6) Press ten keys

7	8	9
4	5	6
1	2	3
0	↔	↔

 ⑥ to input the pattern No. of copy destination.
- 7) Press ENTER button  ⑦.

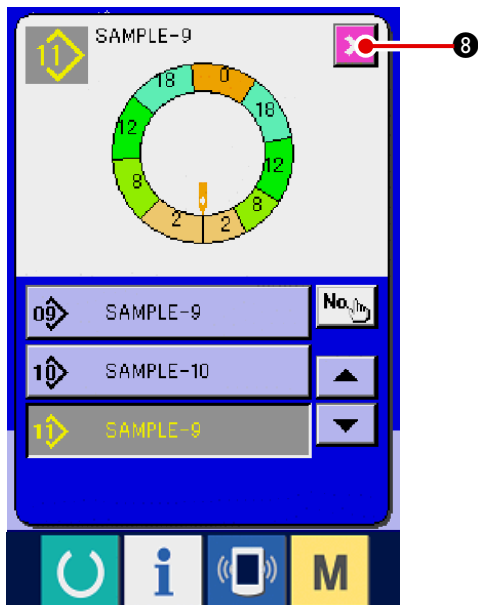

8) Press CANCEL button  8.

* When the number of registered patterns of fully-automatic is 99 patterns, the display is automatically changed over and the pattern is copied to semi-automatic.

8-3 Creating a new pattern <New pattern creation>

The way to newly create a pattern is explained in the application volume.

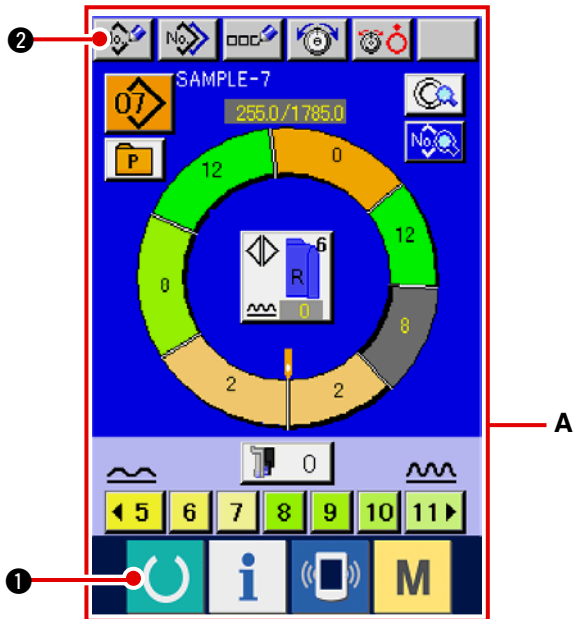

1) Press READY key  1 to change over the screen to data input screen A.

2) Press PATTERN NEW REGISTER button

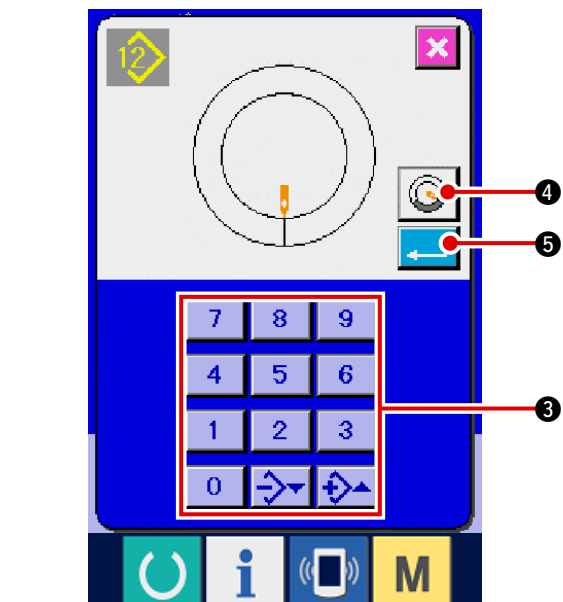

3) Press ten keys

7	8	9
4	5	6
1	2	3
0	↔	↔

 3 to input new

pattern No. (When creating sleeve wadding pattern, press SLEEVE WADDING PATTERN CREATION button  4.)

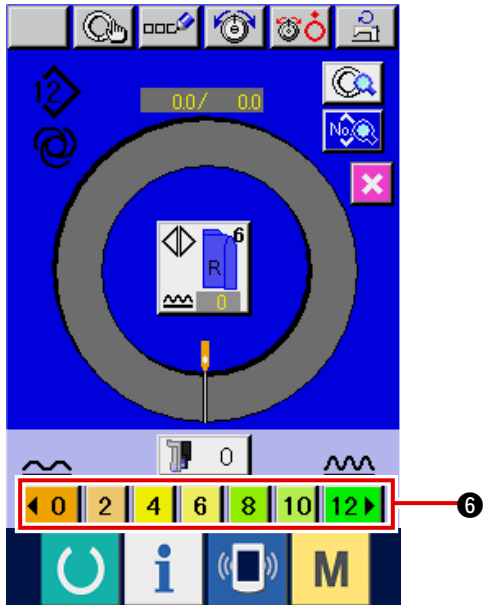

4) Press ENTER button  5.

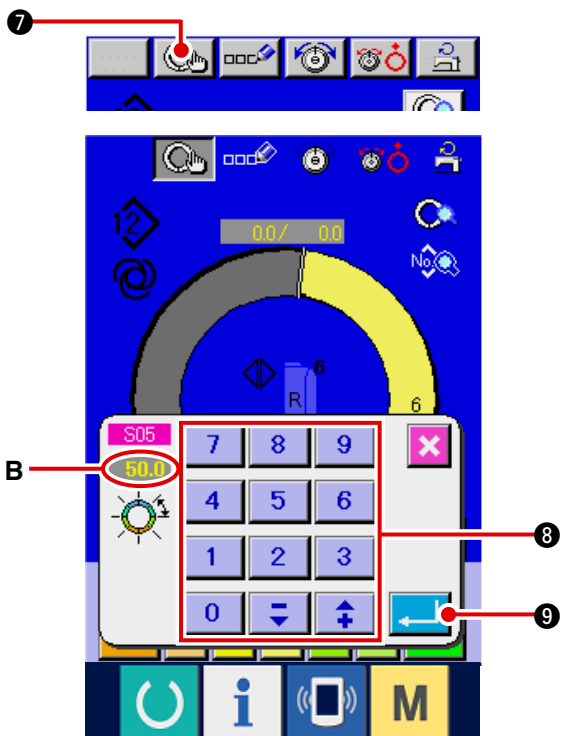

- 5) Change pitch and basic size.
Refer to "[7-6 \(2\) Changing the pitch](#)".
Refer to "[8-1 \(9\) Changing the size](#)".
- 6) Select left/right alternate sewing.
Refer to "[7-5 \(4\) Selecting the left/right alternate sewing](#)".
- 7) Press SHIRRING AMOUNT button
 ⑥ to input the shirring amount.



[In case of manual inputting]

- 8) Press STEP DETERMINATION button  ⑦ to determine the inputted data.
- 9) Press ten keys  ⑧ to input length between steps **B**.
- 10) Press ENTER button  ⑨.

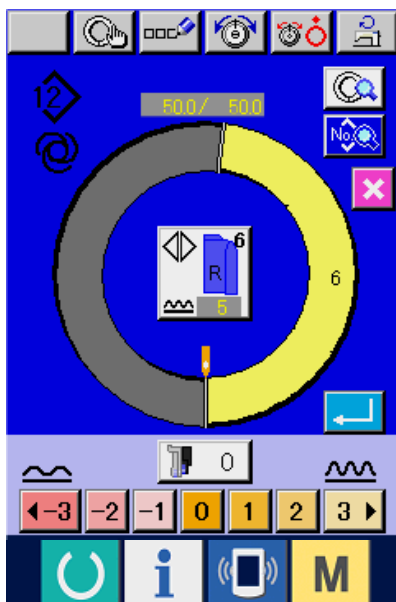

[In case of teaching inputting]

- 8) Set the materials and perform sewing.
- 9) The sewing machine stops at the changeover position of the step.
- 10) Press the knee switch.
- 11) Repeat procedures 7) through 10).

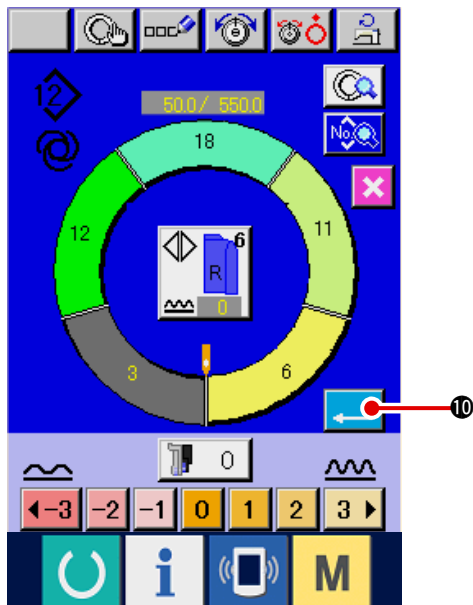

12) Press ENTER button  ⑩ after registering the length between steps, the program of inputted sleeve is registered to the pattern.

8-4 Using other functions

(1) Directly calling the pattern from sewing screen <Direct pattern selection>

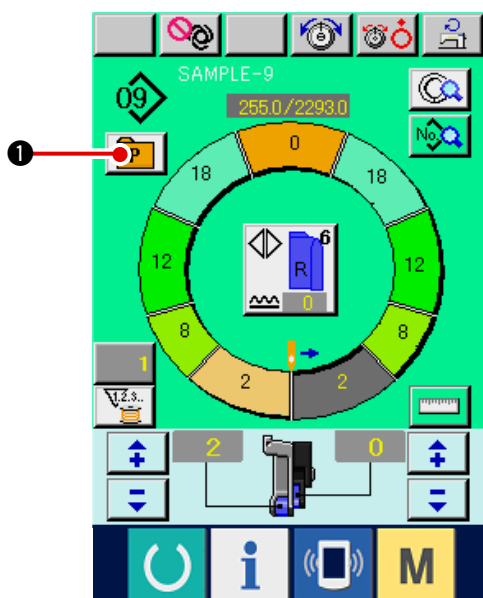



When the patterns which are frequently used are registered to the direct selection button, it is possible to select the patterns with ease from the operating screen by pressing the button only.

* For the way of registering the pattern to the direct selection button, refer to "[12. Registering the pattern to the direct button](#)".

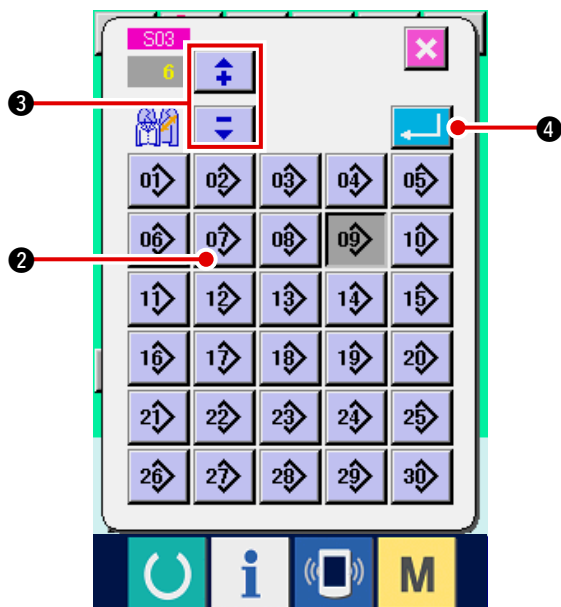
1) Press DIRECT SELECTION button  ①.





2) Press PATTERN SELECTION button  ② to be called.

3) Press "+"/"-" buttons  ③ to select the size.

4) Press ENTER button  ④.

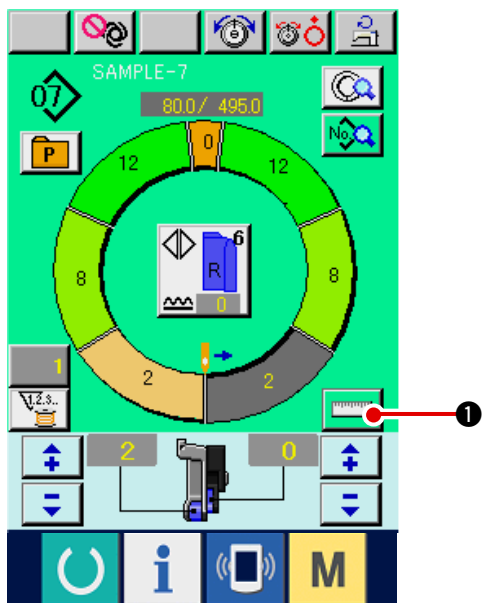
(2) Re-registering the length between steps <Measure function>



- 1) Press MEASURE button  ①.
- 2) Start sewing.
- 3) When sewing is performed up to the next notch, stop the sewing machine once.

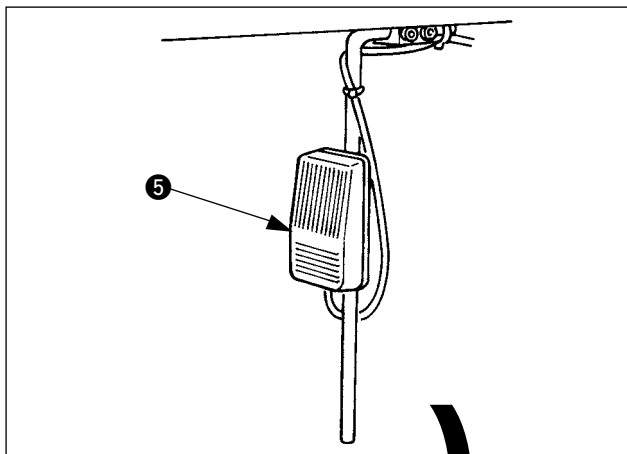

- 4) Press knee switch ⑤ once. Step of the programs advances by one. (A)
- 5) Repeat procedures 2) through 4) until the end of sewing.

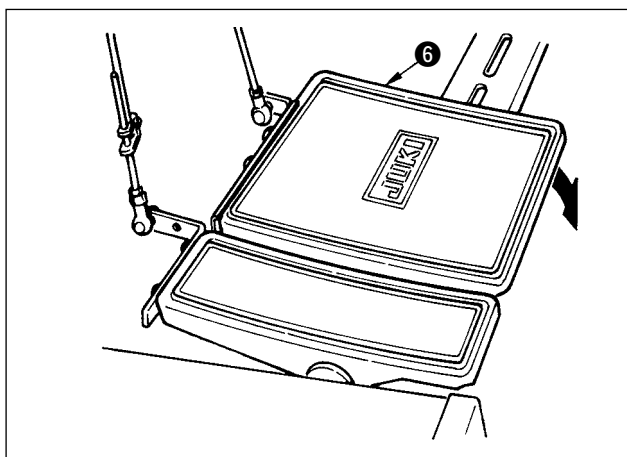
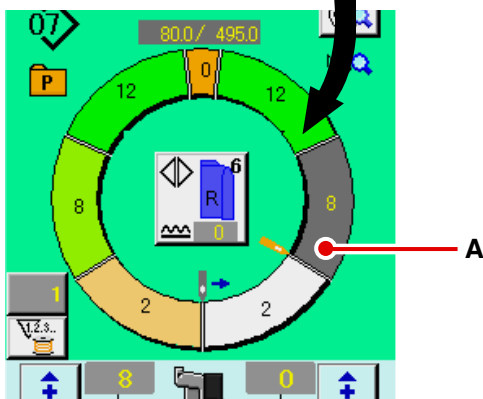

- 6) Perform thread trimming with pedal ⑥.

9. OPERATION OF THE SEWING MACHINE (MANUAL BASIC VOLUME)

9-1 Data input screen

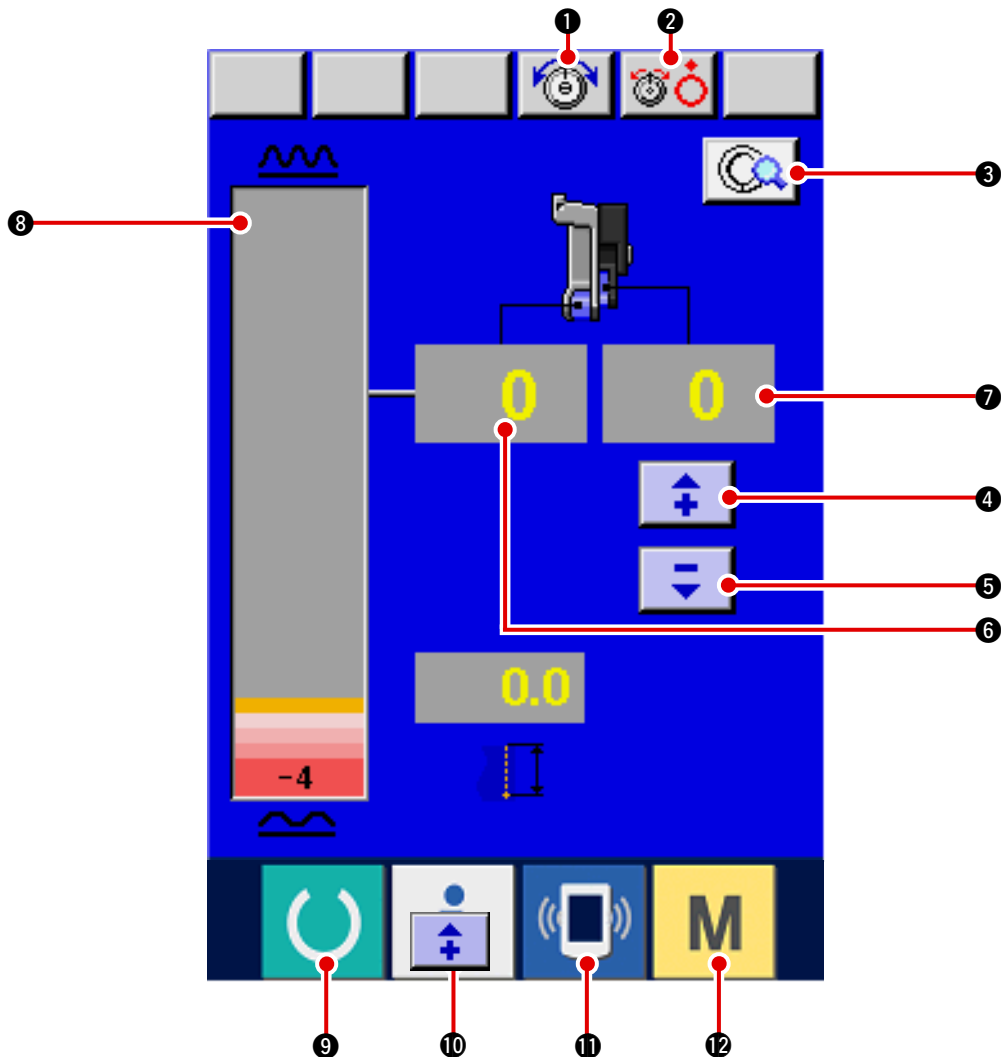

No.	Button	Name of button	Description
①		NEEDLE THREAD TENSION SETTING button	When the button is pressed, needle thread tension change screen is displayed.
②		DISK RISE button	When the button is pressed, thread tension disk No. 1 rises. (Turn OFF the base tension during UIT waiting.)
③		MANUAL DETAILS SETTING button	When the button is pressed, manual sewing details setting screen is displayed.
④		SHIRRING AMOUNT FOR AUXILIARY FEED "+" button	When the button is pressed, shirring amount for auxiliary feed is added by "+1".
⑤		SHIRRING AMOUNT FOR AUXILIARY FEED "-" button	When the button is pressed, shirring amount for auxiliary feed is subtracted by "-1".
⑥		SHIRRING AMOUNT display	Existing shirring amount of feed is displayed.
⑦		SHIRRING AMOUNT FOR AUXILIARY FEED display	Existing shirring amount of auxiliary feed is displayed.
⑧		SHIRRING AMOUNT LEVEL display	Existing shirring amount of feed is displayed on level.

No.	Button	Name of button	Description
⑨		READY key	Changeover of data input screen and sewing screen is performed.
⑩		INFORMATION key	Changeover of data input screen and information screen is performed.
⑪		COMMUNICATION key	Changeover of data input screen and communication screen is performed.
⑫		MODE key	Changeover of data input screen and mode changeover screen to perform various details setting is performed.



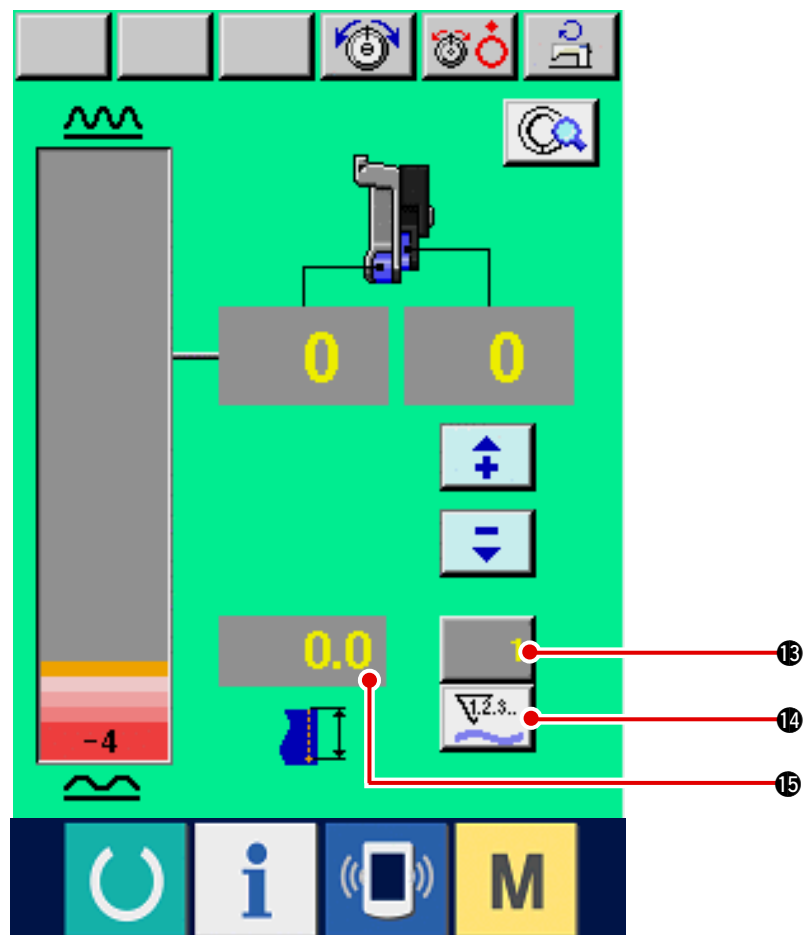



9-2 Sewing screen

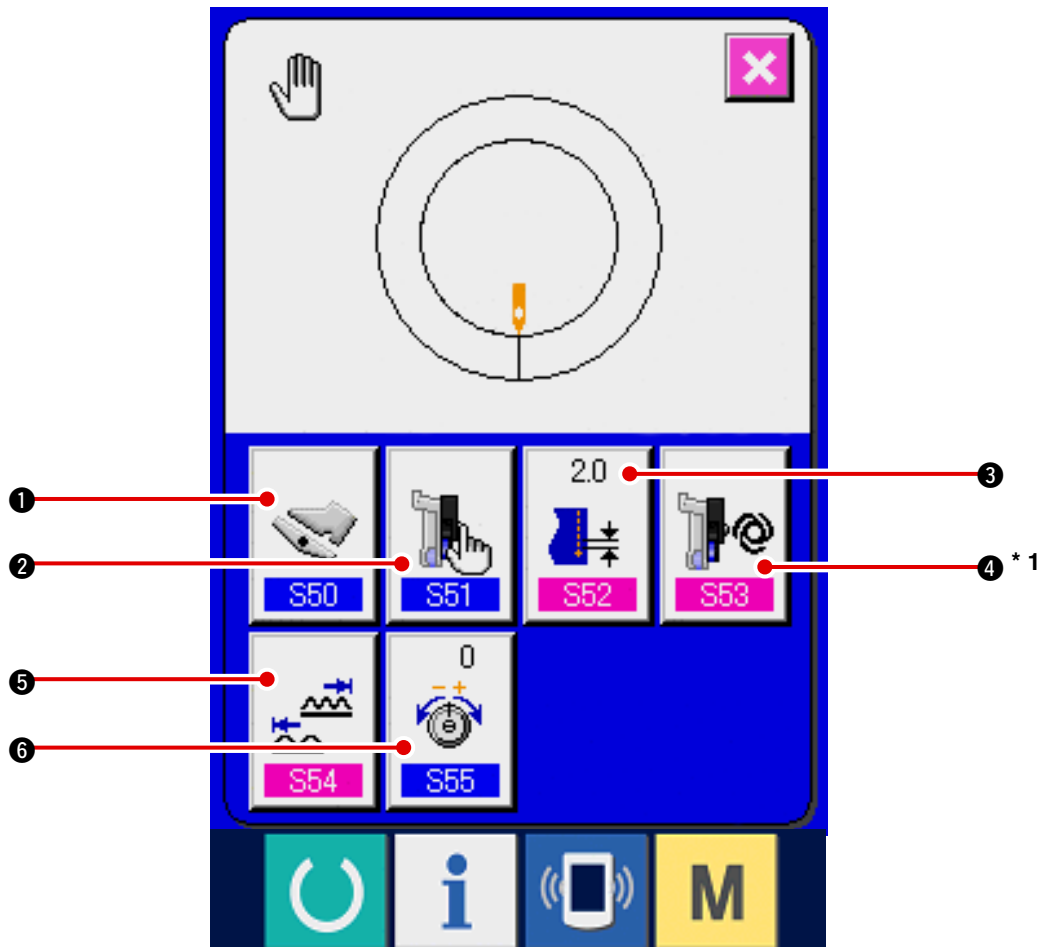

No.	Button	Name of button	Description
⑬		COUNTER VALUE CHANGE button	When the button is pressed, bobbin/No. of pcs. counter setting screen is displayed.
⑭		COUNTER CHANGEOVER button	When the button is pressed, bobbin/No. of pcs. counter is changed over alternately.
⑮		SEWING LENGTH display	Sewing length when sewing is displayed. When thread trimming is performed, display is cleared to "0".

9-3 Details data input screen



No.	Button	Name of button	Description
①		AUXILIARY PEDAL OPERATION MODE SELECTION button	When the button is pressed, auxiliary pedal operation mode selection screen is displayed.
②		AUXILIARY FEED MODE SELECTION button	When the button is pressed, auxiliary feed operation mode selection screen is displayed.
③		BASE PITCH SETTING button	When the button is pressed, base pitch setting screen is displayed.
④		AUXILIARY FEED INTERLOCK MODE SETTING button	When the button is pressed, auxiliary feed interlock mode setting screen is displayed. * 1 Display/Non display is changed over according to the contents of setting of S51 .
⑤		SHIRRING AMOUNT RANGE SETTING button	When the button is pressed, shirring amount range setting screen is displayed.
⑥		COMPENSATION THREAD TENSION CHANGE button	When the button is pressed, compensation thread tension setting screen is displayed.

9-4 Basic operation of the sewing machine

(1) Prepare the materials.

Prepare left and right sleeves, and garment body.

(2) Turn the power ON.

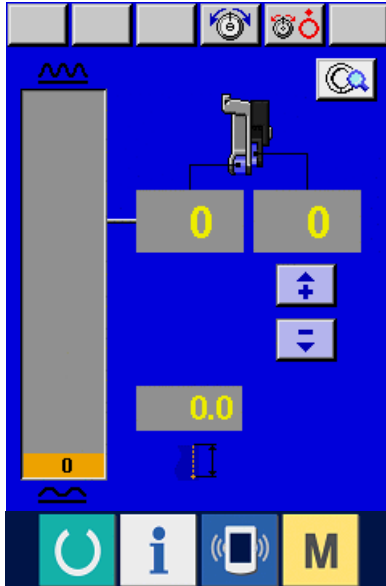



- 1) Turn the power switch ON.
- 2) Data input screen is displayed after the initial screen was displayed.

Caution Auto-lifter does not work until the screen moves to the sewing screen. After it has worked, it works in all screens. So, be careful.

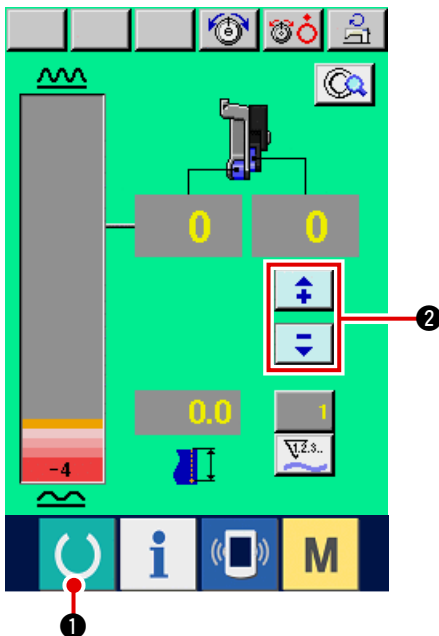
(3) Perform sewing.



- 1) Press READY switch  ① to change over the screen to sewing screen.
- 2) Input set value with SHIRRING AMOUNT FOR AUXILIARY FEED buttons   ② .

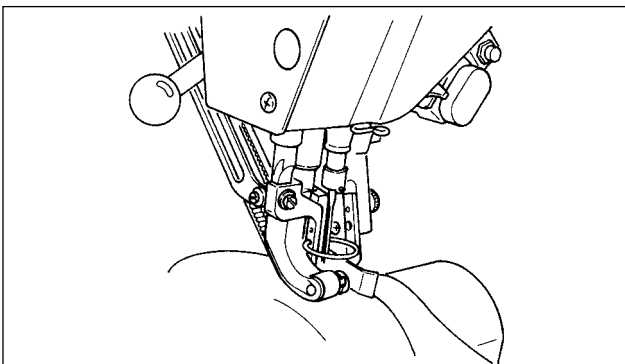

- 3) Set sleeves and garment body on the sewing machine.
- 4) Start sewing.

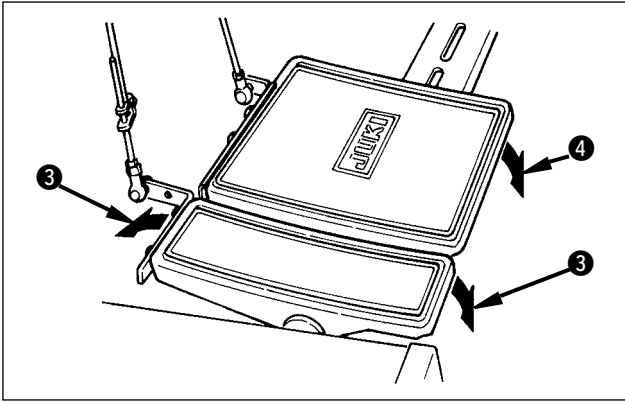

- 5) Adjust the shirring amount with auxiliary pedal ③.
- 6) Perform thread trimming with pedal ④ at the end of sewing.

9-5 Changing the basic set value

(1) Changing the sewing speed <Max. sewing speed setting>

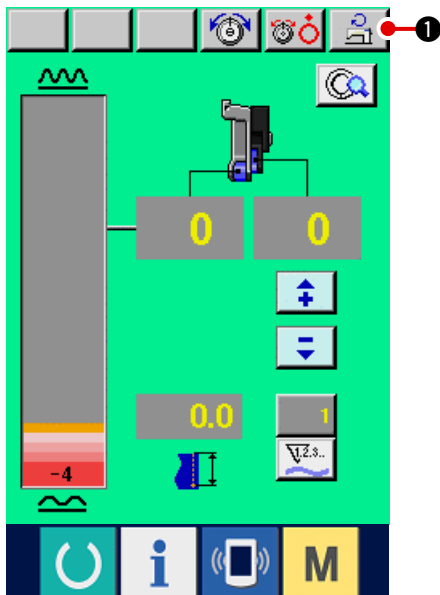

- 1) Press MAX. SEWING SPEED SETTING button

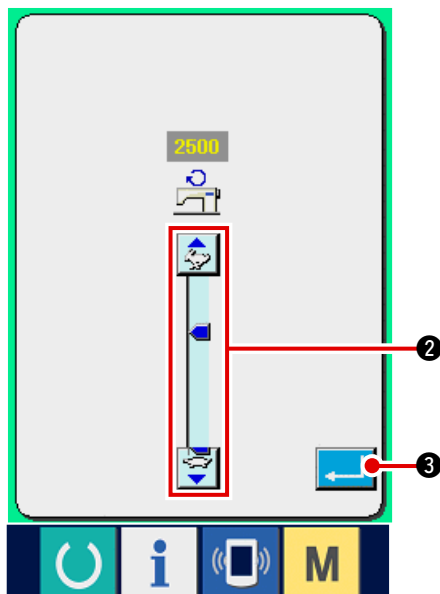

- 2) Press MAX. SEWING SPEED CHANGE button

 (fast) and  (slow) ② to change the sewing speed.

- 3) Press ENTER button  ③.

(2) Changing the pitch <Pitch setting>



1) Press MANUAL DETAILS SETTING button

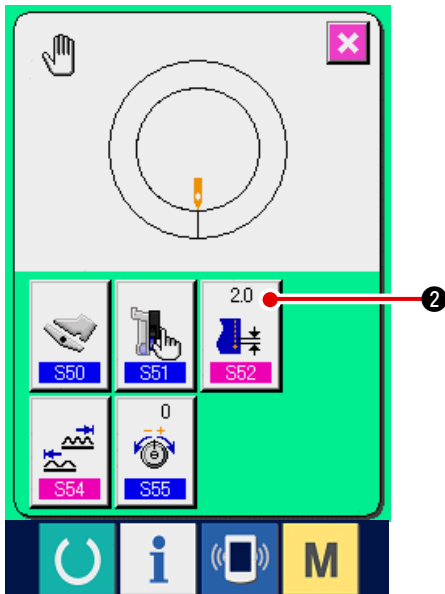

2) Press BASE PITCH SETTING button

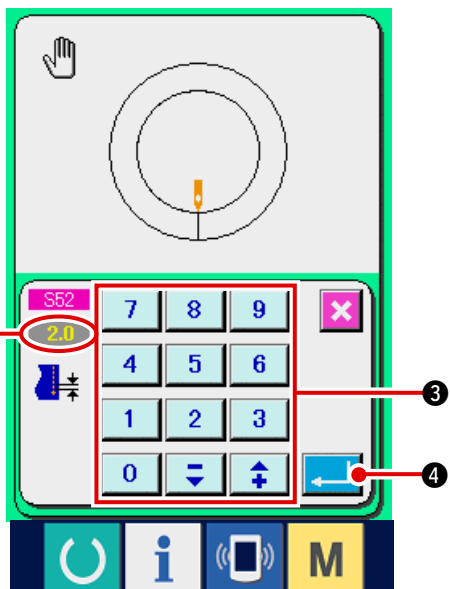

3) Input base pitch set value **A** with ten keys



4) Press ENTER key



(3) Changing the needle thread tension <Needle thread tension setting>

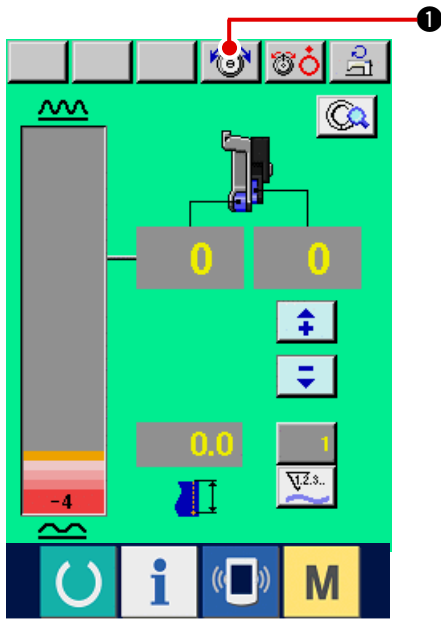

- 1) Press NEEDLE THREAD TENSION CHANGE button  1.

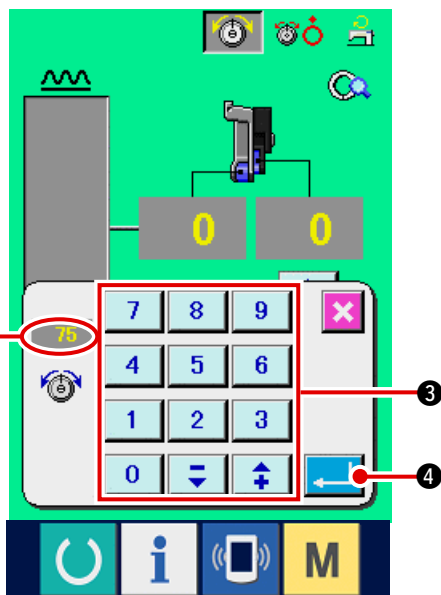

- 2) Input needle thread tension set value A with ten



- 3) Press ENTER button  4.

10. OPERATION OF THE SEWING MACHINE (MANUAL APPLICATION VOLUME)

10-1 Changing the detailed set value

(1) Changing the operating mode of auxiliary pedal <Auxiliary pedal operation selection>

Changing from interlock mode A to step mode B

"What is the interlock mode like ?"

It is the mode that "shirring amount" changes with the interlock of the depressing amount of auxiliary pedal.

"What is step mode like ?"

It is the mode that "shirring amount" increases by +1 when depressing the front-part of auxiliary pedal and "shirring" amount decreases by -1 when depressing the back-part of auxiliary pedal.

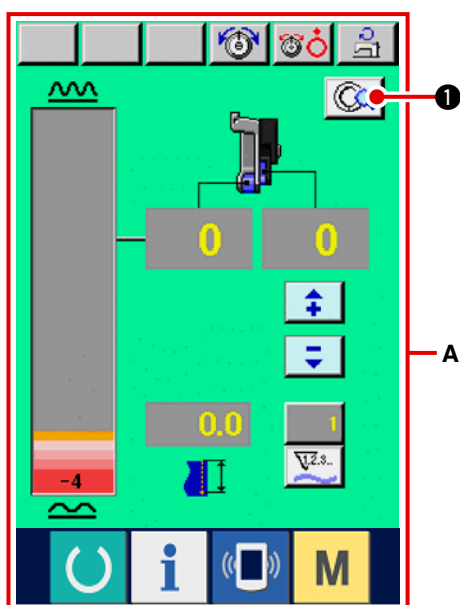

1) Press MANUAL DETAILS SETTING button



* A is the interlock mode screen.

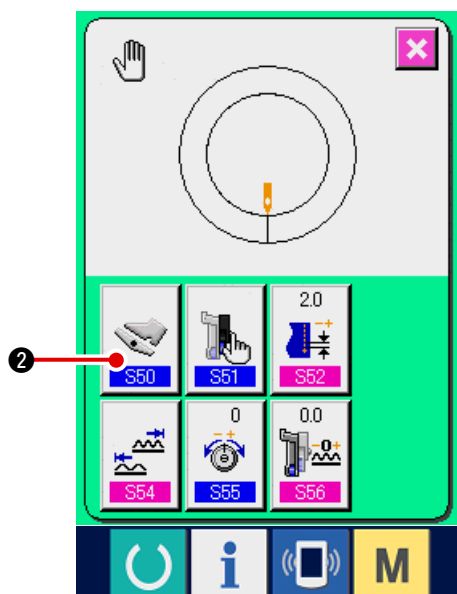

2) Press AUXILIARY PEDAL OPERATING MODE

SELECTION button



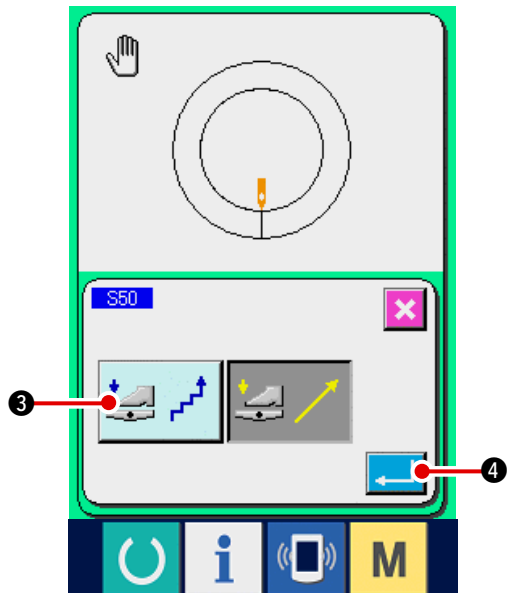

3) Press STEP MODE SELECTION button  3.

* When step mode is selected, shirring amount range setting **S54** is fixed to - 4 to + 35.

4) Press ENTER button  4.



5) Press CANCEL button  5.

(2) Changing the auxiliary feed operating mode <Auxiliary feed mode selection>

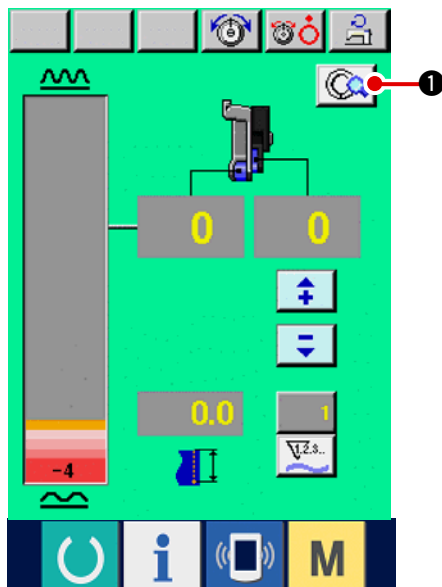



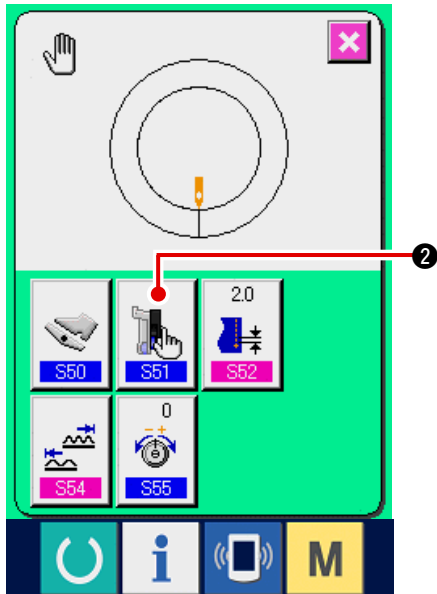

1) Press MANUAL DETAILS SETTING button  1.

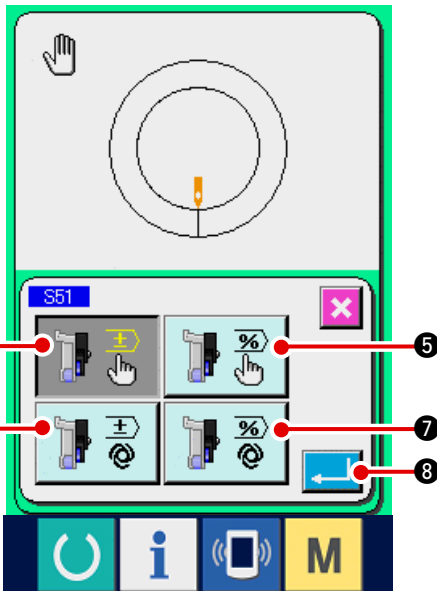



2) Press AUXILIARY FEED MODE SELECTION



3) Select the auxiliary feed operating mode.

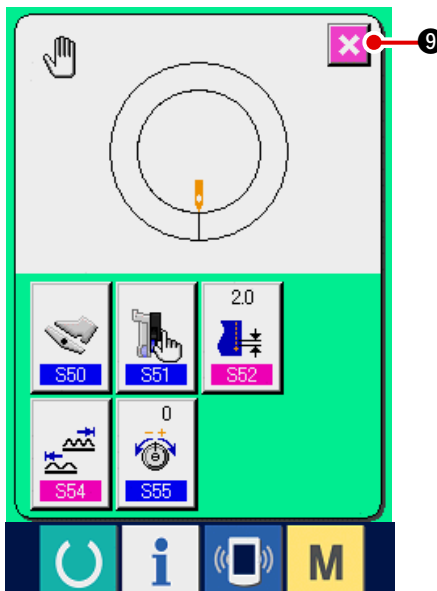

-  ④ : Fixed value can be manually inputted by numeral and set.
-  ⑤ : Fixed value can be manually inputted by ratio (%) and set.
-  ⑥ : Operation interlocking the shirring amount is performed. Setting is performed by numeral inputting with "[10-1 \(3\) Auxiliary feed interlock mode setting](#)".
-  ⑦ : Operation interlocking the shirring amount is performed. Setting is performed by ratio (%) inputting with "[10-1 \(3\) Auxiliary feed interlock mode setting](#)".



4) Press ENTER button  ⑧.

5) Press CANCEL button  ⑨.

(3) Setting the auxiliary feed interlock mode <Auxiliary feed interlock mode setting>

It is the setting when  ⑥ or  ⑦ of the previous item 3) is selected at "10-1 (2) Changing the operating mode of auxiliary feed".

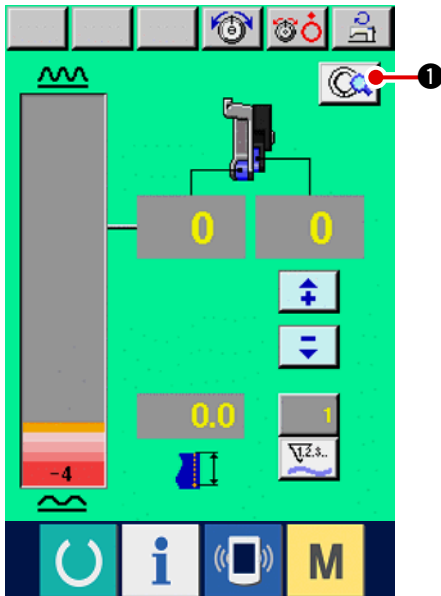

1) Press MANUAL DETAILS SETTING button

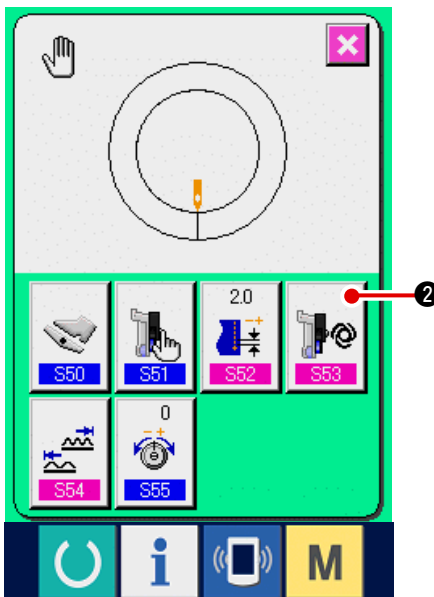

2) Press AUXILIARY FEED INTERLOCK MODE

SETTING button



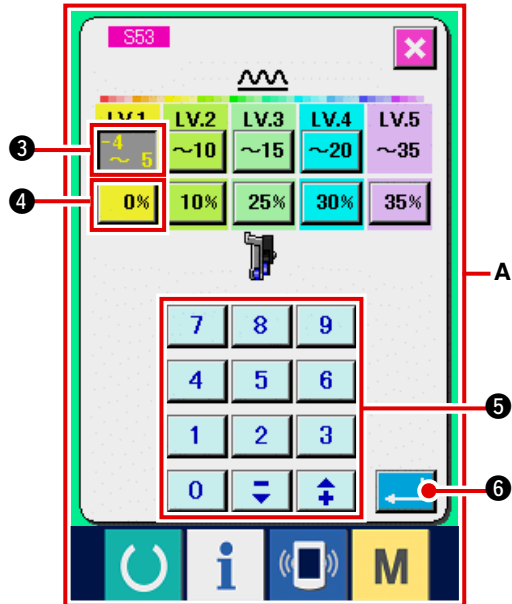

3) Perform the auxiliary feed interlock mode setting.

1. Press SHIRRING AMOUNT RANGE SETTING button **0%** ③ of LV.1 and input the upper limit value of shirring amount range of LV.1 with ten

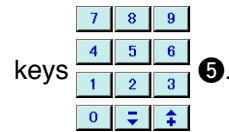

2. Next, press AUXILIARY FEED SHIRRING AMOUNT SETTING button **0%** ④ of LV.1 to input auxiliary feed shirring amount value of LV.1



Similarly, set the value of LV.2, LV.3, LV.4 and LV.5.

Display A in the screen shows as follows :

- When shirring amount is – 4 to 5, auxiliary feed shirring amount value is 0%.
- When shirring amount is 6 to 10, auxiliary feed shirring amount value is 10%.
- When shirring amount is 11 to 15, auxiliary feed shirring amount value is 25%.
- When shirring amount is 15 to 20, auxiliary feed shirring amount value is 30%.
- When shirring amount is 21 to 35, auxiliary feed shirring amount value is 35%.

* When inputting ratio (%), the set value is corrected by 5% unit.



4) Press ENTER button  ⑥.

5) Press CANCEL button  ⑦.

(4) Setting the range of shirring amount <Shirring amount range setting>

It is the setting when the interlock mode is selected at "10-1 (1) Changing the operating mode of auxiliary pedal".

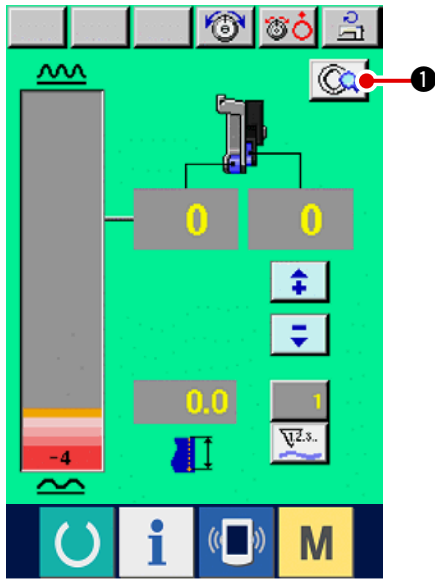

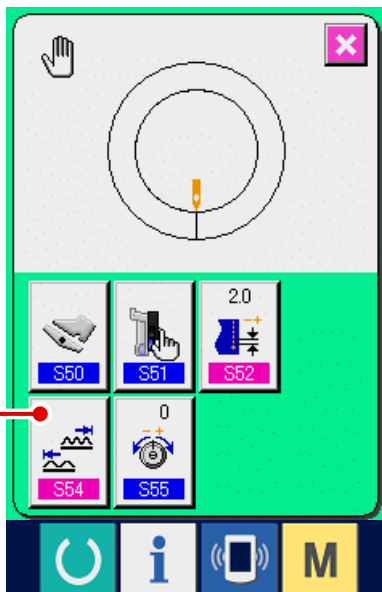

1) Press DETAILS SETTING button  ①.

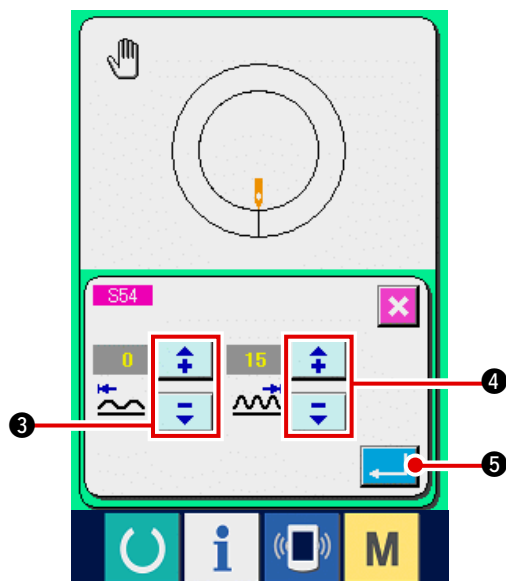

2) Press SHIRRING AMOUNT RANGE SETTING button  ②.



3) Input the lower limit value of shirring amount range with  buttons ③.

4) Input the upper limit value of shirring amount range with  buttons ④.

5) Press ENTER button  ⑤.

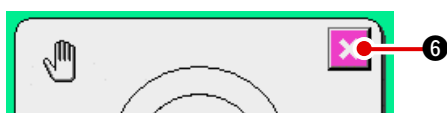

6) Press CANCEL button  ⑥.

(5) Setting the compensation thread tension <Compensation thread tension setting>

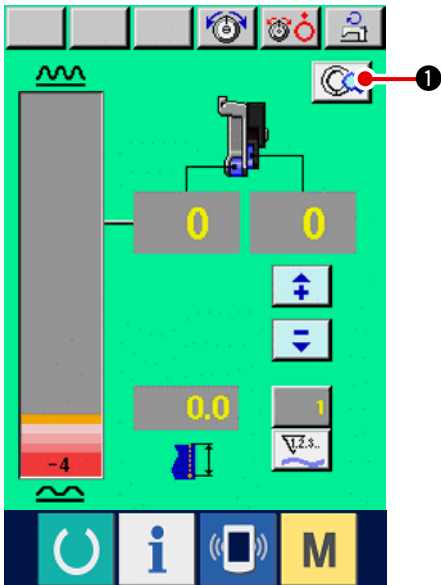

1) Press MANUAL DETAILS SETTING button

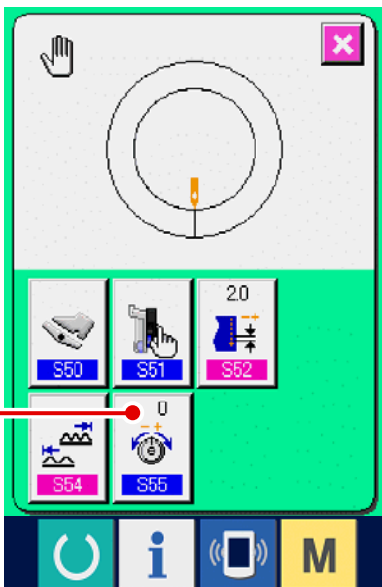

2) Press COMPENSATION THREAD TENSION

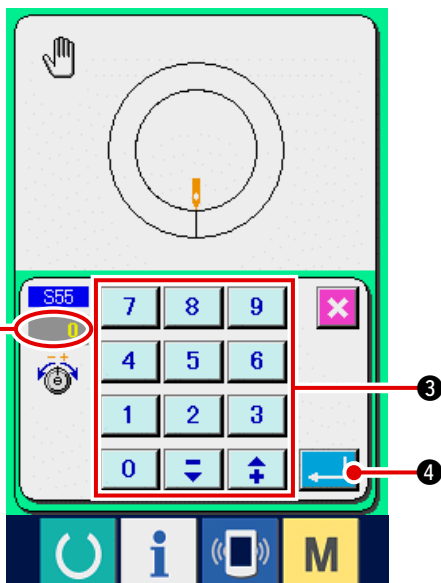

3) Input compensation thread tension set value **A**

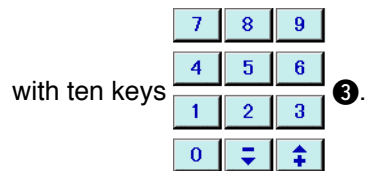

4) Press ENTER button





5) Press CANCEL button  5.

11. USING COUNTER

11-1 Setting procedure of the counter

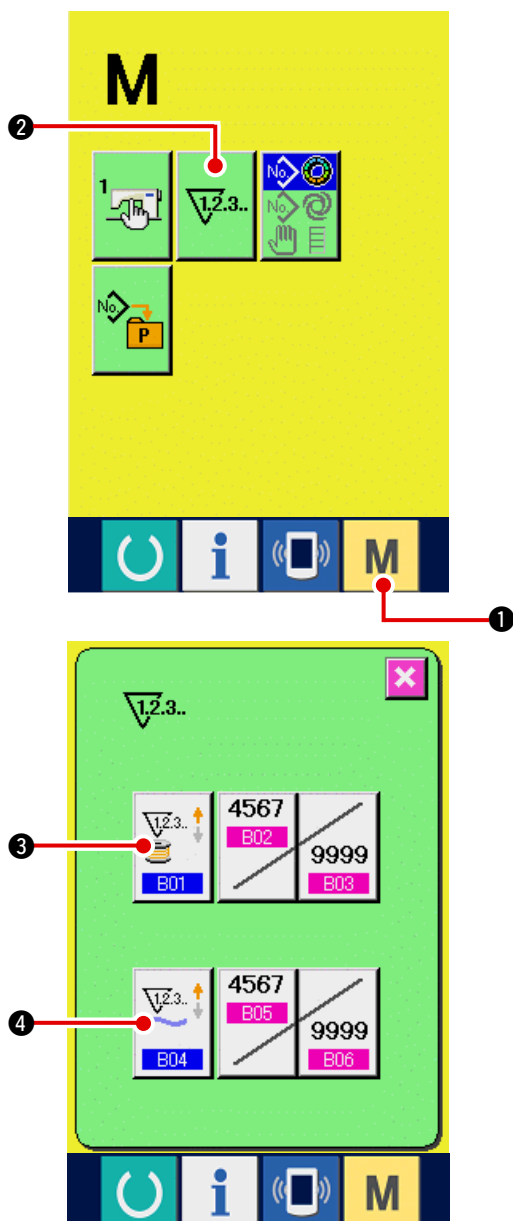

1) Display the counter setting screen.

When MODE key  1 is pressed,

COUNTER SETTING button  2 is displayed.

When this button is pressed, the counter setting screen is displayed.

2) Selection of kinds of counters

This sewing machine has two kinds of counters, i. e., sewing counter and No. of pcs. counter.

Press SEWING COUNTER KIND SELECTION

button  3 or NO. OF PCS.

KIND SELECTION button  4 to display

the counter kind selection screen. The kinds of the respective counters can be set separately.

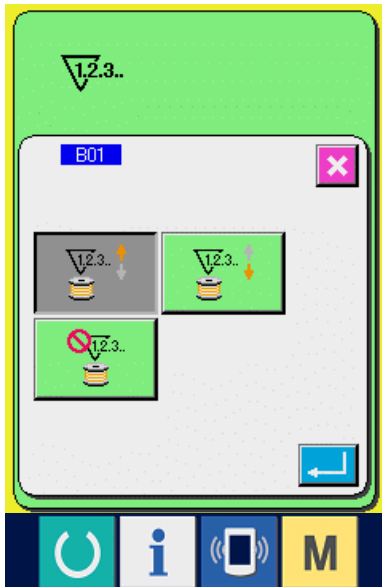

[Sewing counter]

UP counter  :

Every time the sewing is performed, the existing value is counted up. When the existing value is equal to the set value, the count-up screen is displayed.

DOWN counter  :

Every time the sewing is performed, the existing value is counted down. When the existing value is reached to "0", the count-up screen is displayed.

Counter not used  :

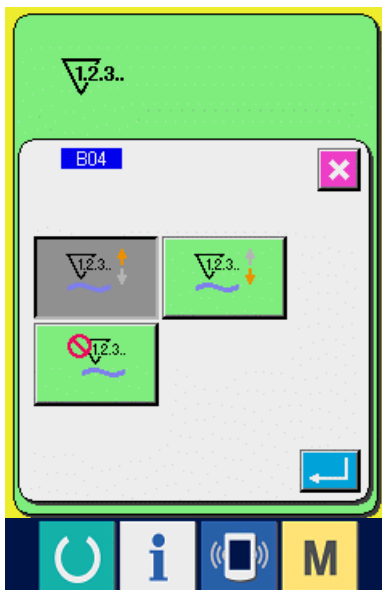

[No. of pcs. counter]

UP counter  :

Every time the sewing of one sleeve (every time thread trimming is performed in case of manual sewing), existing value is counted up. When the existing value is equal to the set value, the count-up screen is displayed.

DOWN counter  :

Every time the sewing of one sleeve (every time thread trimming is performed in case of manual sewing), existing value is counted down. When the existing value becomes "0", the count-up screen is displayed.

Counter not used  :

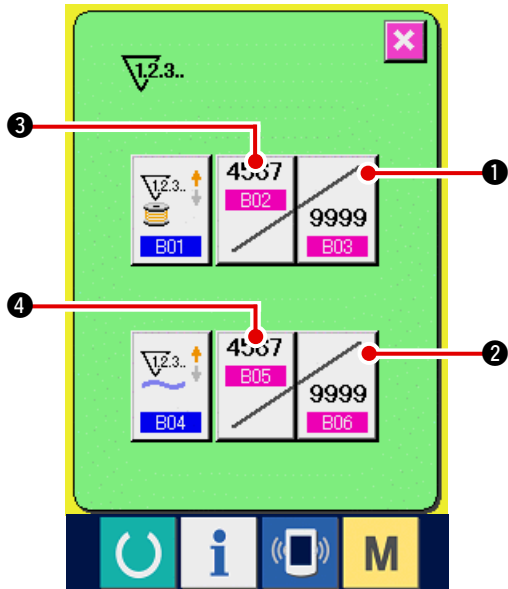

3) Change of counter set value

In case of the sewing counter, press **SEWING COUNTER SET VALUE CHANGE** button



1, and in case of the No. of pcs. counter, press

NO. OF PCS. COUNTER SET VALUE CHANGE

button



2, and the set value input screen is displayed. Here, input the set value.

(Refer to screen A.)

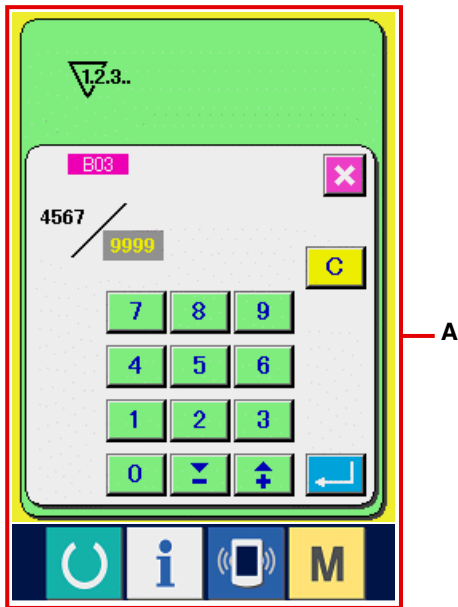

4) Change of counter existing value

In case of the sewing counter, press **SEWING COUNTER EXISTING VALUE CHANGE** button



3, and in case of the No. of pcs. counter,

press **NO. OF PCS. COUNTER EXISTING VALUE CHANGE** button



4 and the existing value input screen is displayed. Here, input the existing value.

(Refer to screen B.)

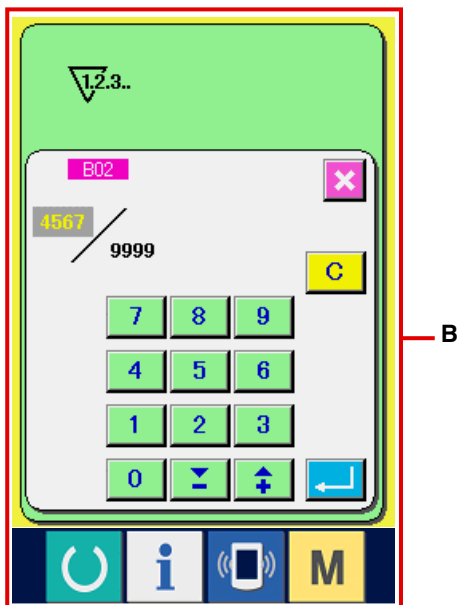

11-2 Count-up releasing procedure

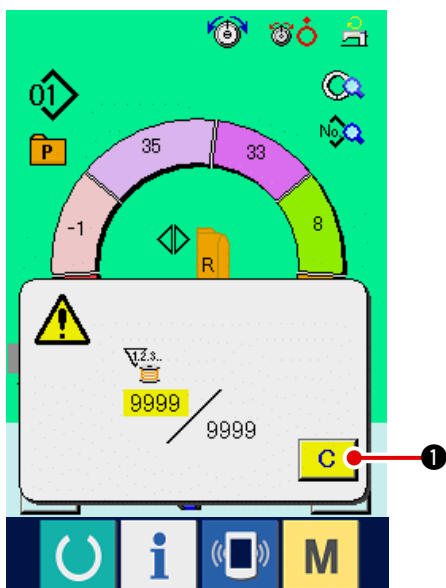

When count-up condition is reached during sewing work, the count-up screen is displayed and the buzzer beeps. Press CLEAR button **C** **1** to reset the counter and the screen returns to the sewing screen. Then the counter starts counting again.

12. REGISTERING THE PATTERN TO DIRECT BUTTON

Register the pattern No. which are frequently used with the direct buttons for use.

Once the patterns are registered, the pattern selection can be performed with ease by pressing only the button.

12-1 How to register

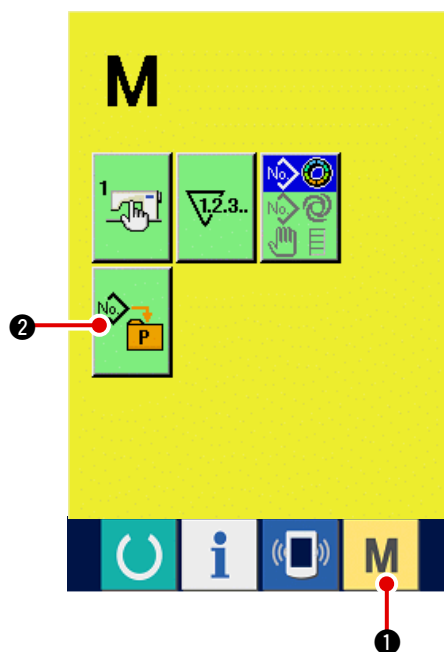

1) Display the direct pattern register screen.

When **M** **1** switch is pressed, direct pattern

register button **No.** **P** **2** is displayed on the screen.

When this button is pressed, the direct pattern register screen is displayed.

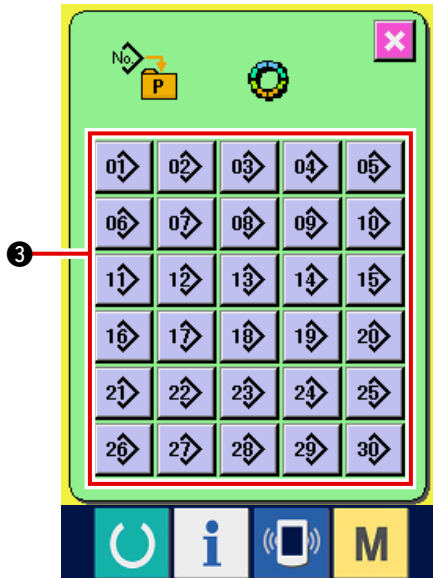

2) Select the button to be registered.

Direct patterns can be registered up to 30 patterns.

30 direct buttons

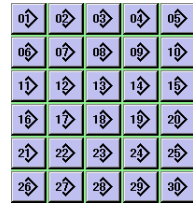

are

displayed on the screen. When the button located on the position you desire to register is pressed, the pattern No. list screen is displayed.

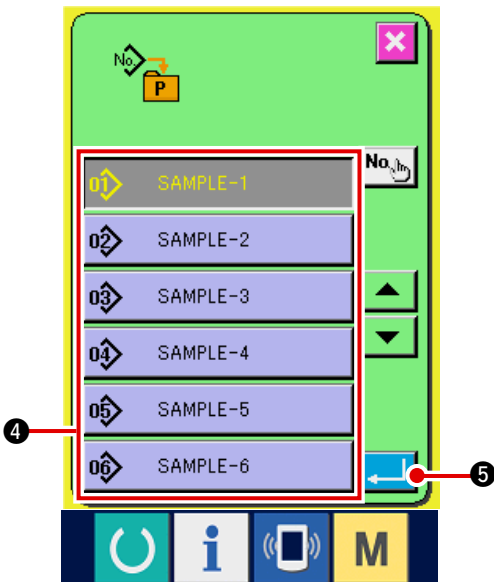

3) Select the pattern No. to be registered.

Select the pattern No. you desire to register

from among pattern No. buttons

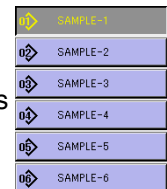

are

When the selected button is pressed twice, the selection is released.

4) Register the direct pattern.

When ENTER button  is pressed, the register of direct pattern is finished and the direct pattern No. register screen is displayed. The registered pattern No. is displayed on the direct button.

12-2 Register state at the time of your purchase

Pattern Nos. 1 to 10 have been registered at the time of your purchase.

13. CHANGING SEWING MODE

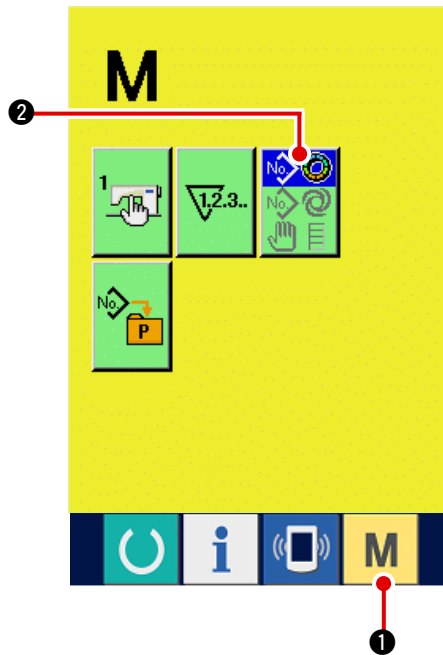

1) Display the sewing mode selection screen.

When MODE key **M** ① is pressed, MODE

SELECTION button  ② is displayed on the screen.

2) Select the sewing mode.

Press MODE SELECTION button  ② to select the sewing mode you desire to sew.

* Image of the button of the sewing mode selection button changes according to the sewing mode which is selected at present.

When semi-automatic sewing is selected :



When fully-automatic sewing is selected :



When manual sewing is selected :



3) Determine the sewing mode.

When MODE key **M** ① is pressed, the sewing mode data input screen is displayed.

14. CHANGING MEMORY SWITCH DATA

14-1 Changing procedure of memory switch data

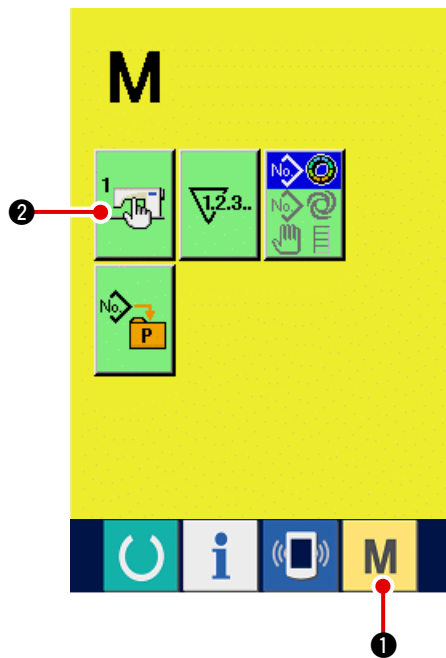

1) Display the memory switch data list screen.

When MODE key **M** ① is pressed, MEMORY

SWITCH button ② is displayed on the

screen.

When this button is pressed, the memory switch data list screen is displayed.

2) Select the memory switch button you desire to change.

Press UP/DOWN SCROLL button



③ and select the data item button



④ you desire to change.

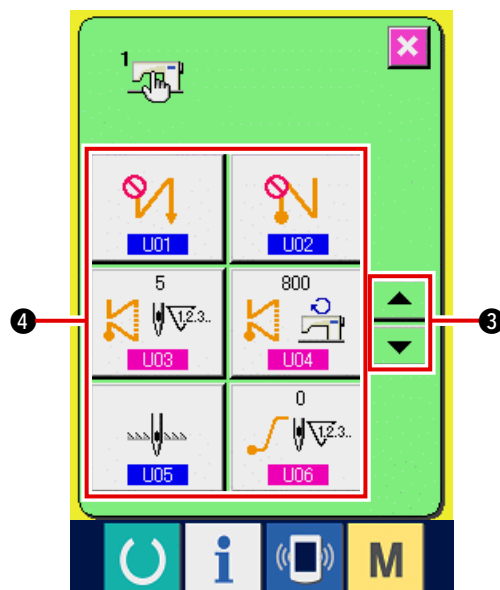

3) Change the memory switch data.

There are data items to change numerals and those to select pictographs in the memory switch data. No. in pink color such as **U03** is put on the data items to change numerals and the set value can be changed with ten keys and +/- buttons displayed in the change screen.



















No. in blue color such as **U01** is put on the data items to select pictographs and the pictographs displayed in the change screen can be selected.

For the details of memory switch data, refer to ["14-2 Memory switch data list"](#).















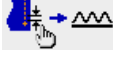

14-2 Memory switch data list

1) Level 1

Memory switch data (level 1) are the motion data that the sewing machine has in common and the data that operate on all sewing patterns in common.





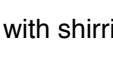





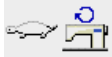
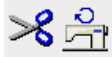
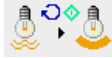

No.	Item	Setting range	Edit unit	Initial display
U01	Reverse stitching at the sewing start selection Select from among three kinds of without, single and double.  : Without  : Single  : Double	---	---	Without
U02	Reverse stitching at the sewing end selection Select from among three kinds of without, single and double.  : Without  : Single  : Double	---	---	Without
U03	Number of stitches of reverse stitching Number of stitches at the sewing start and that at the sewing end are set. 	0 to 19	1 stitch	5 stitches
U04	Reverse stitching speed Speed of the reverse stitching at the sewing start and the sewing end is set. 	200 to 3000	10rpm	800rpm
U05	Needle position at the time of stop Needle position at the time of temporary stop during sewing is selected.  : DOWN  : UP	---	---	DOWN
U06	Number of stitches of soft start setting Number of stitches of soft start at the sewing start is set. 	0 to 9	1 stitch	0 stitch
U07	Soft start speed setting Speed of soft start at the sewing start is set. 	200 to 2000	10rpm	800rpm
U08	Condensation sewing selection Select from among four kinds of without, start only, end only and both start and end.  : Without  : Start  : End  : Both	---	---	Without
U09	Number of stitches of condensation Number of stitches of condensation sewing is set. 	0 to 9	1 stitch	0 stitch
U10	Condensation speed setting Speed of condensation sewing is set. 	200 to 2000	10rpm	800rpm
U11	Base tension in waiting state Base tension in waiting state (except during sewing) is set. 	0 to 200	1	20

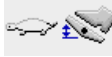







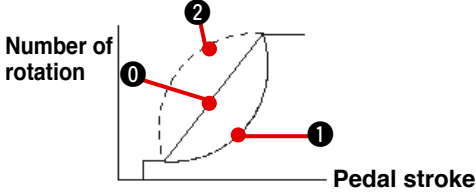







No.	Item	Setting range	Edit unit	Initial display
U12	Compensation tension mode selection Select from among manual (numerical value), manual (level) and automatic.  : Numerical value  : Level  : Automatic For setting procedure of the manual (numerical value), refer to " 14-3 (1) Explanation of compensation tension manual (numerical value) ".	---	---	Manual numerical value)
U13	Compensation tension manual (level) setting This item is displayed when "manual (level)" is selected in U12 Compensation tension mode selection. Compensation tension value for each level is set. → Refer to " 14-3 (2) Explanation of compensation tension manual (level) ".	- 200 to 200	1	Level 1) 10 Level 2) 20 Level 3) 30
U14	Compensation tension automatic setting This item is displayed when "automatic" is selected in U12 Compensation tension mode selection. Compensation tension value for each shirring amount range is set. → Refer to " 14-3 (3) Explanation of compensation thread tension automatic ".	Shirring amount - 4 to 35 Compensation tension value - 200 to 200	---	---
U15	Shirring smoothing function setting Use of shirring smoothing function is selected. → Refer to " 14-4 Explanation of the shirring smoothing function ".  : Unused  : Use	---	---	Unused
	Number of stitches of shirring smoothing function setting Number of stitches of shirring smoothing function is set. 	0 to 99	1 stitch	1 stitch
	Shirring smoothing function shirring amount setting Shirring amount of shirring smoothing function is set. 	1 to 35	1	1
U16	Data storing function at the time of sewing Whether storing data or not when data is changed in the sewing screen is selected.  : No storing  : Storing	---	---	Storing
U17	Sound output at the time of changeover of step selection Whether buzzer sounds or not when step is changed over is selected.  : No sound  : Sound	---	---	No sound
U18	Auxiliary pedal use selection Use of auxiliary pedal is selected.  : Unused  : Use ①  : Use ② Shirring amount changes according to the depressing amount of auxiliary pedal. Shirring amount increases by +1 by depressing the front part of auxiliary pedal and decreases by -1 by depressing the back part of auxiliary pedal.	---	---	Use ②







No.	Item	Setting range	Edit unit	Initial display
U19	<p>Shirring release switch use selection Use of shirring release switch is selected.</p> <p> : Unused</p> <p> : Used as shirring release</p> <p> : Used as reverse feed stitching</p> <p> : Used both as shirring release and thread trimming prohibition</p> <p> : Used both as reverse stitching and thread trimming prohibition</p> <p>* In case the switch is used as the reverse stitching one, shirring release button is displayed on the panel when the display setting is performed with K26 Reverse stitching button display selection.</p>	---	---	Used as shirring release
U20	<p>Knee switch use selection Whether knee switch for step changeover is used or not is selected.</p> <p> : Unused  : Use</p>	---	---	Use
U21	<p>Shirring amount interlock function at the time of change of pitch selection Whether shirring amount set to each step at the time of change of pitch is corrected or not according to the change amount of pitch is selected.</p> <p> : Not correct  : Correct</p>	---	---	No changeover
U22	<p>Screen changeover function at the time of thread trimming on the way selection Whether screen is changed over or not when thread trimming is performed at the step other than the last step is selected.</p> <p> : No changeover  : Changeover</p>	---	---	No changeover
U23	<p>Auxiliary feed input mode selection Whether auxiliary feed input is performed with offset numerical value or % ratio is selected.</p> <p> : Numerical value  : Ratio</p>	---	---	Numerical value
U24	<p>Shirring amount increase/decrease input mode S02 Whether Shirring amount increase/decrease value input is performed with offset numerical value or with % ratio is selected.</p> <p> : Numerical value  : Ratio</p>	0 to 200	1	Numerical value
U25	<p>Start position change way selection Whether the change of start position is interlocked with shirring data or only the start position moves is selected.</p> <p> : Interlocked with shirring data</p> <p> : Only start position moves.</p>	---	---	Interlocked with shirring data

2) Level 2

Memory switch data (level 2) can be edited when pressing MODE switch for as long as 6 seconds.

No.	Item	Setting range	Edit unit	Initial display
K01	Presser position after thread trimming selection Position of the presser after thread trimming is set.  : DOWN  : UP	---	---	UP
K02	Max. sewing speed setting Max. sewing speed of the sewing machine is set. 	200 to 3500	10rpm	3500rpm
K03	Sewing speed at low speed setting Min. sewing speed of the sewing machine is set. 	200 to 400	5rpm	200rpm
K04	Sewing speed of thread trimming setting Sewing speed at the time of thread 	100 to 250	5rpm	160rpm
K05	This function is set when hand lamp flickers. 0 : Without flicker reduction function 1 : Less effective → 8 : more effective 	0 to 8	1	0
K06	Rotation start pedal stroke setting Stroke from the neutral position of pedal to sewing machine rotation start position is set. 	1.0 to 5.0	0.1mm	3.0mm
K07	Pedal low speed section Section from pedal neutral position to sewing machine acceleration start position is set. 	1.0 to 10.0	0.1mm	6.0mm
K08	Pedal presser lifting start position Section from pedal neutral position to cloth presser lifting start position is set. 	- 1.0 to - 6.0	0.1mm	- 2.1mm
K09	Thread trimming start pedal stroke Section from pedal neutral position to thread trimming start position is set. 	- 1.0 to - 6.0	0.1mm	- 5.1mm
K10	Pedal max. number of rotation reach stroke Section from pedal neutral position to max. number of rotation reach position is set. 	1.0 to 15.0	0.1mm	15.0mm
K11	Pedal neutral position compensation Compensation value of neutral point of pedal is set. 	- 15 to 15	1	- 1
K12	Auto-lifter lifting holding time Waiting time of lifting the presser lifter is set. 	10 to 600	10sec	60sec
K13	Pedal curve selection function Curve of the number of rotation of the sewing machine in terms of pedal depressing amount is selected.  0 : Straight line  1 : Square  2 : Square root 	---	---	Straight line

No.	Item	Setting range	Edit unit	Initial display
K14	Reverse rotation to lift needle after thread trimming function selection Sewing machine is rotated in the reverse direction after thread trimming, and needle bar is lifted near to its upper dead point.  : Ineffective  : Effective	---	---	Ineffective
K15	Reverse stitching at the sewing start A/M changeover function selection Designation of sewing speed of reverse stitching at the sewing start is selected.  : In accordance with the speed by manual operation of pedal or the like  : In accordance with the speed set by U04 Reverse stitching speed	---	---	Speed by manual operation
K16	Stop function immediately after reverse stitching at the sewing start selection Function to make the sewing machine stop once when reverse stitching at the sewing start is completed  : Without function  : With function	---	---	Without function
K17	Condensation/EBT changeover speed Initial speed at the time of start of EBT (reverse stitching at the sewing end) is set. 	0 to 250	10rpm	170rpm
K18	Retry function selection Function to make the sewing machine rotate again in the normal direction with max. torque after rotating the machine in the reverse direction once when the sewing machine is locked is selected.  : Without retry function  : With retry function	---	---	Without retry function
K19	Sewing machine start-up curve selection Start-up curve of the sewing machine is selected.  : Normal curve  : More sharp curve	---	---	Normal curve
K20	Presser position at the time of stop of the sewing machine selection Position of the presser foot when the sewing machine temporarily stopped is selected.  : DOWN  : UP	---	---	DOWN
K21	Size class setting Initial value (size country class, gents'/ladies' selection, and basic size) when creating a new pattern is set.  → Refer to " 14-5 Explanation of the size class ".	---	---	Japan Gentlemen No. 6 3%
K22	Initial pitch setting Initial value of pitch when creating a new pattern is set. 	1.5 to 6.0	0.1mm	2.0mm
K23	Bottom feed amount compensation value setting Compensation value of set value and actual value of bottom feed amount is set. 	-1.0 to 1.0	0.1mm	0mm

No.	Item	Setting range	Edit unit	Initial display
K24	Top feed amount compensation value setting Compensation value of set value and actual value of top feed amount is set. 	-1.0 to 1.0	0.1mm	0mm
K25	Thread tension curve selection Inclination of thread tension curve is selected.  : Standard  : Gentle (thin materials)	---	---	Standard
K26	Reverse stitching button display selection Display of reverse stitching button in the sewing screen is selected.  : Non-display  : Display	---	---	Non- display
K27	Dish-rise timing setting Disk-rise timing from the start of thread trimming is set. 	0 to 40	1	18
K28	Length of remaining thread setting Length of remaining needle thread at the time of thread trimming is set. When the set value is changed, the disk-close timing from the disk-rise 	0 to 40	1	5



When the contents of level 2 have been changed, the screen becomes POWER OFF screen after pressing CLOSE button . Accordingly turn ON the power again after turning OFF the power once.

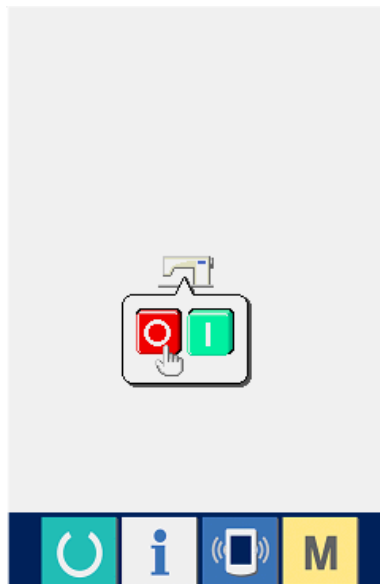

"POWER OFF screen"

14-3 Explanation of compensation thread tension

The sewing machine is capable of changing over the setting procedure of compensation tension in the data input screen and the step details setting in the sewing screen by selection of the compensation tension mode.

(1) Explanation of compensation tension manual (numerical value)

Compensation thread tension manual (numerical value) is the way to directly input numerical value when inputting the compensation thread tension value that can be set to each step. Next, the setting procedure is explained.

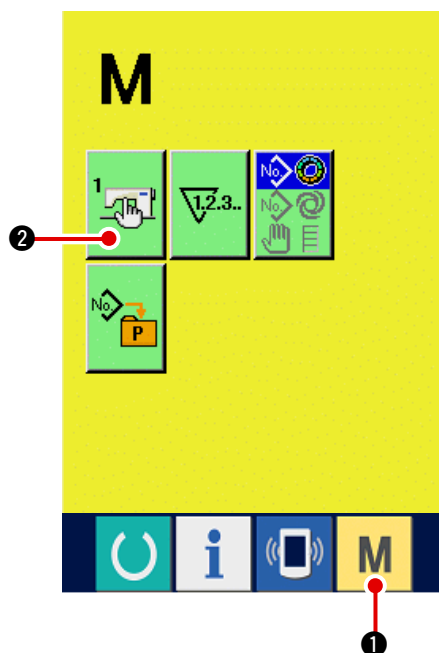

1) Display the memory switch list screen.

When MODE key **M** ① is pressed,

MEMORY SWITCH button  ② is displayed

on the screen. When this button is pressed, the memory switch list screen is displayed.

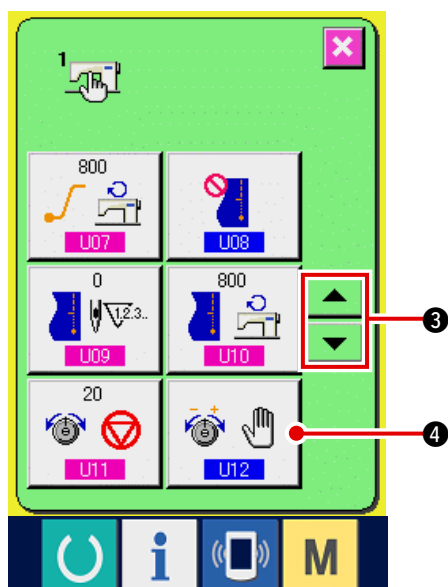

2) Select **U12** Compensation tension mode.

Press UP/DOWN SCROLL buttons 

 ③ to select **U12** Compensation

thread tension selection button  ④.

Compensation tension mode selection screen is displayed.

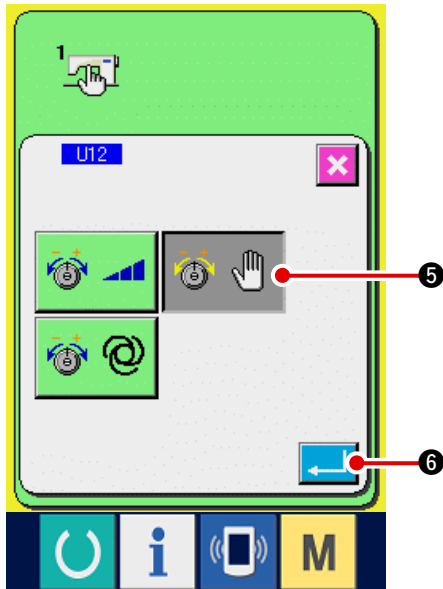



3) **Make the compensation tension manual (numerical value) effective.**

Select EFFECTIVE button  5.

4) **Determine the compensation tension manual (numerical value)**

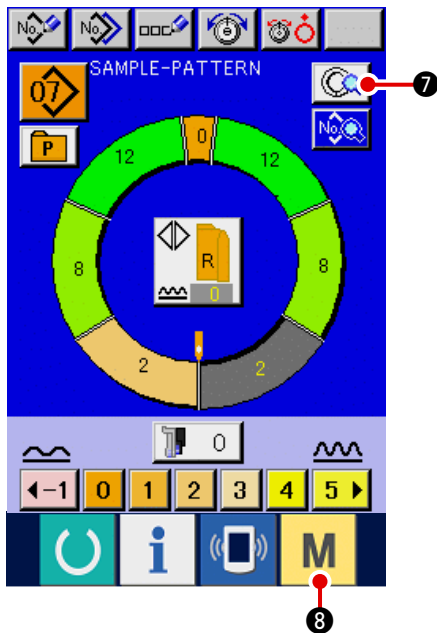
When ENTER button  6 is pressed, the compensation tension mode selection screen is closed and selection of the compensation tension mode is completed. And, the screen returns to the memory switch list screen.



When READY switch **M** 8 is pressed, data input screen is displayed. Press STEP DETAILS SETTING button  7 to open the step details screen.

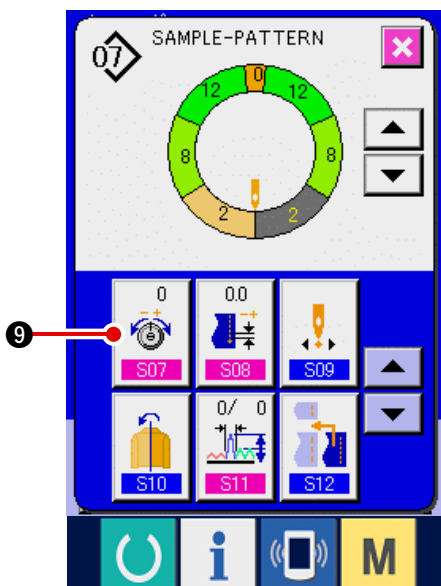

5) **Select the setting screen of S07 Compensation tension manual (numerical value).**

Press **S07** Compensation thread tension setting button  9 in the screen to display compensation thread tension pop-up screen.

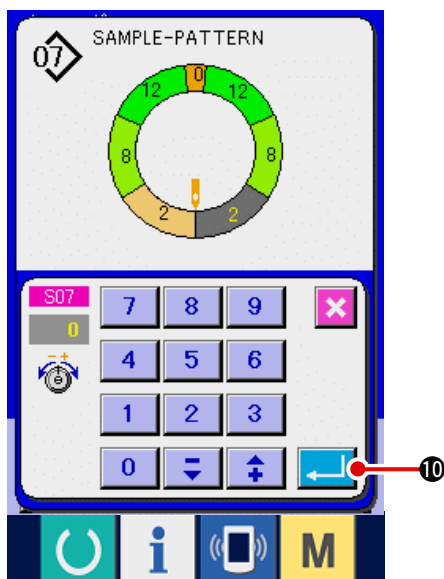

6) Set the compensation tension manual (numerical value).

Input the compensation tension value for the step to be selected with numerical value. The inputted numerical value is added to or subtracted from the needle thread tension value in motion as the offset value.

When ENTER button  ⑩ is pressed, the compensation thread tension pop-up screen is closed to determine the compensation tension setting value.

And, the screen returns to the step details screen.

(2) Explanation of compensation tension manual (level)

Compensation thread tension manual (level) is the way to perform inputting with the level selection when inputting the compensation thread tension value that can be set to each step. Next, the setting procedure is explained.

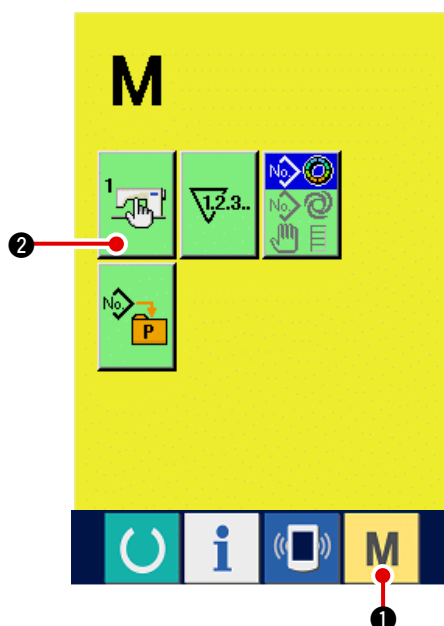

1) Display the memory switch list screen.

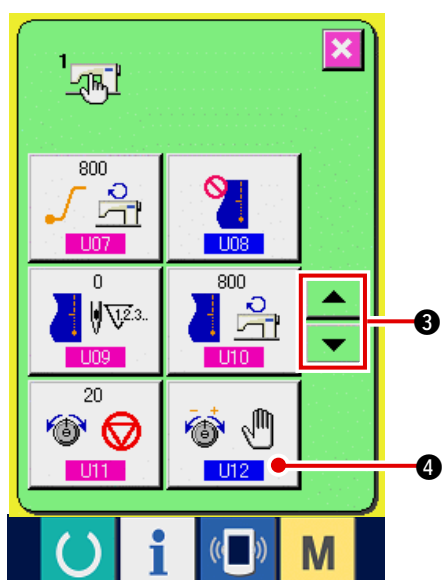

When MODE key  ① is pressed,

MEMORY SWITCH button  ② is displayed on the screen. When this button is pressed, the memory switch list screen is displayed.



2) Select **U12** Compensation tension mode.

Press UP/DOWN SCROLL buttons 

 ③ to select **U12** Compensation thread tension mode selection button  ④.

Compensation tension mode selection screen is displayed.

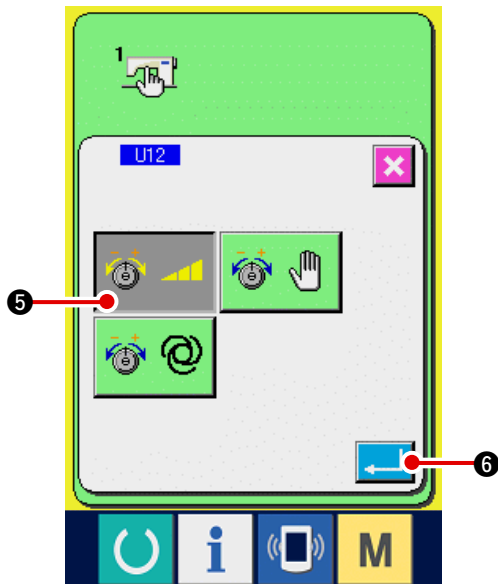

3) Make the compensation tension manual (level) effective.



Select EFFECTIVE button  **5**.

4) Determine the compensation tension manual (level).

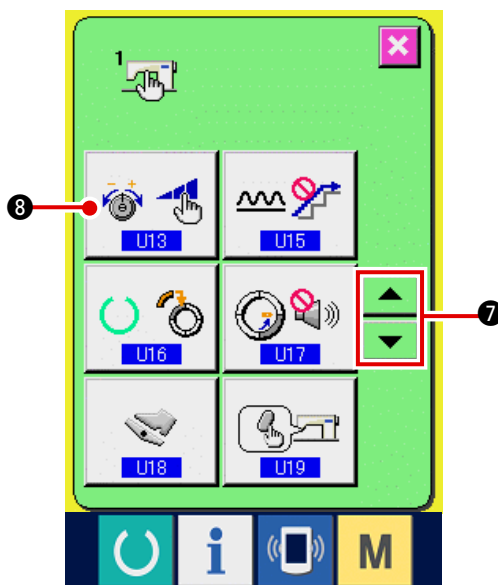
When ENTER button  **6** is pressed, the compensation tension mode selection screen is closed and selection of the compensation tension mode is completed. And, the screen returns to the memory switch list screen.



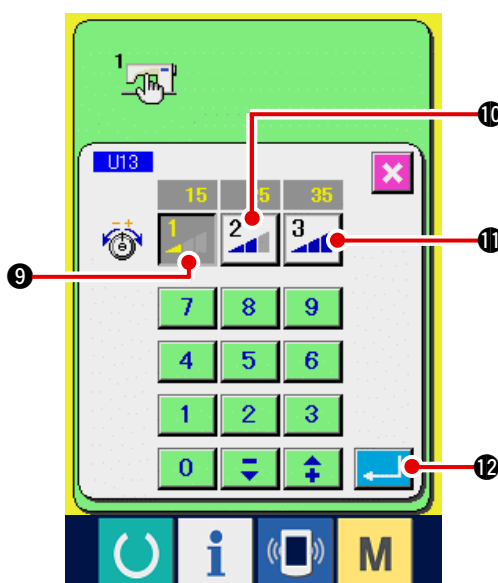

5) Select U13 Compensation tension mode.

Press UP/DOWN SCROLL buttons  **7** to select **U13** Compensation tension manual (level) button  **8**. Compensation tension mode selection screen is displayed.



6) Set the level value of compensation thread tension manual (level).

Press LEVEL 1 button  **9** to input the set value.

Press LEVEL 2 button  **10** to input the set value.

Press LEVEL 3 button  **11** to input the set value.

When the setting is completed, press ENTER button  **12** to close the compensation tension mode selection screen. Then the selection of compensation thread tension manual (level) is completed.

And, the screen returns to the memory switch list screen.

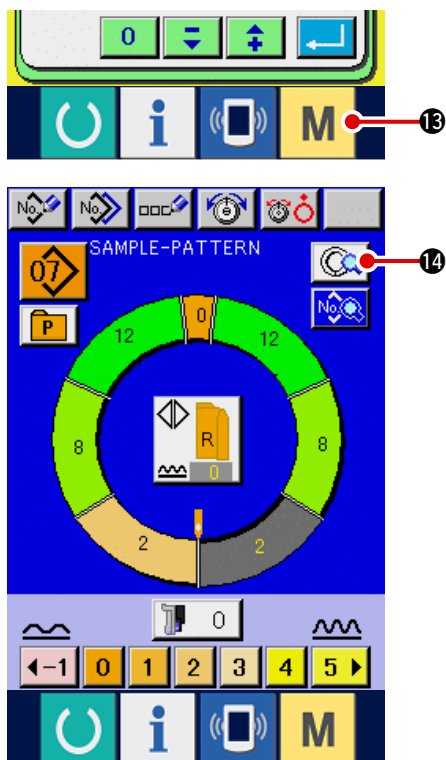

When MODE key **M** 13 is pressed, the data input screen is displayed. Press STEP DETAILS SETTING button  14 to open the step details screen.

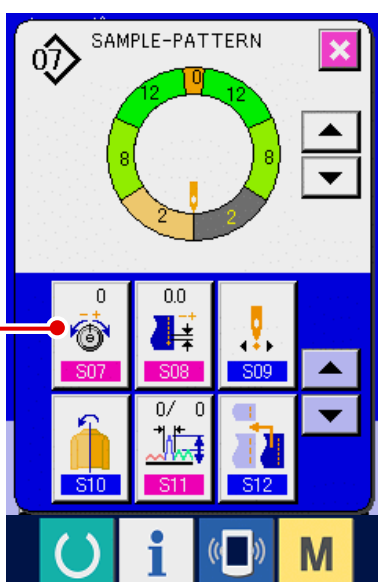

7) Select **S07 Compensation tension manual (level) setting** screen.

Press **S07 Compensation thread tension** setting button  15 in the screen to display the compensation thread tension pop-up screen.

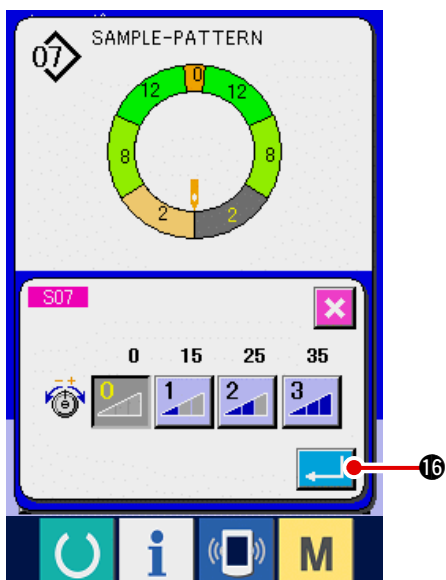

8) **Set the compensation tension manual (level).** Select the level of compensation thread tension for the step to be selected.

Compensation thread tension value set to the selected level is added to or subtracted from the needle thread tension value as the offset value.

When ENTER button  16 is pressed, the compensation thread tension pop-up screen is closed and the compensation thread tension set value is determined. And, the screen returns to the step details screen.

(3) Explanation of compensation thread tension automatic

Compensation thread tension automatic is the way to automatically assign the compensation thread tension value based on the shirring amount to which the compensation thread tension value that can be set for each step is set. Next, the setting procedure is explained.

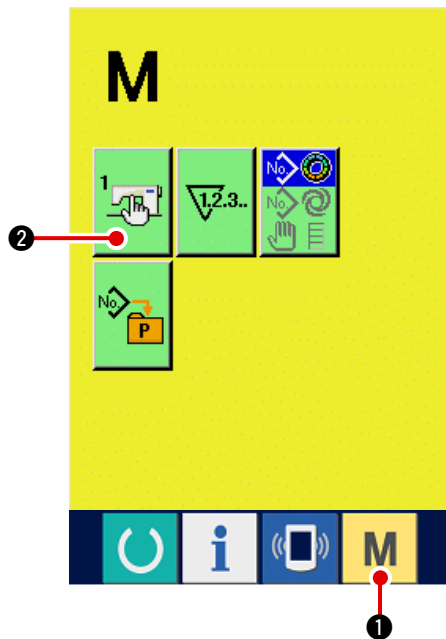

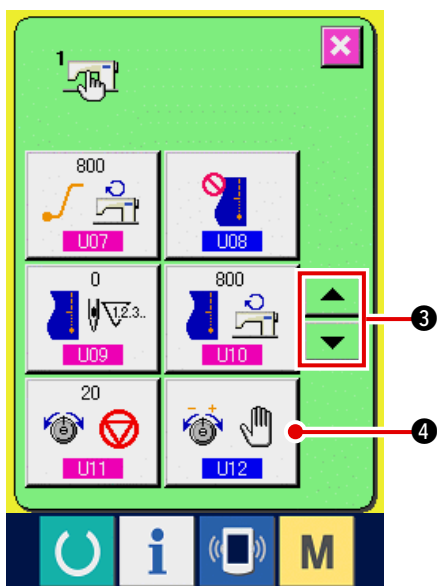

1) Display the memory switch list screen.

When MODE key **M** ① is pressed, MEMORY SWITCH button  ② is displayed on the screen. When this button is pressed, the memory switch list screen is displayed.



2) Select the compensation tension mode.

Press UP/DOWN SCROLL buttons  ③ to select **U12** Compensation thread tension mode selection button  ④. Compensation tension mode selection screen is displayed.

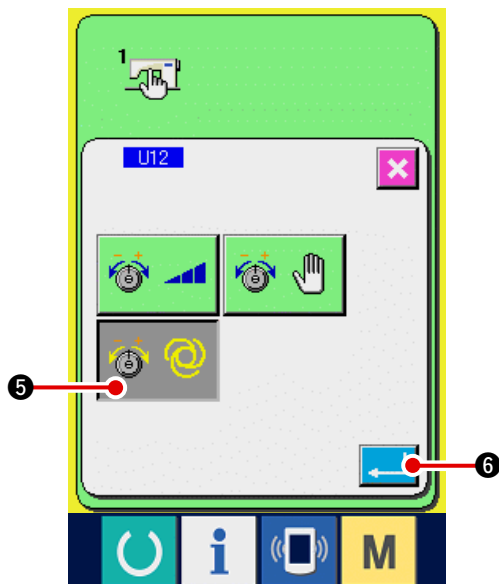

3) Make the compensation tension automatic effective.

Select EFFECTIVE button  ⑤.

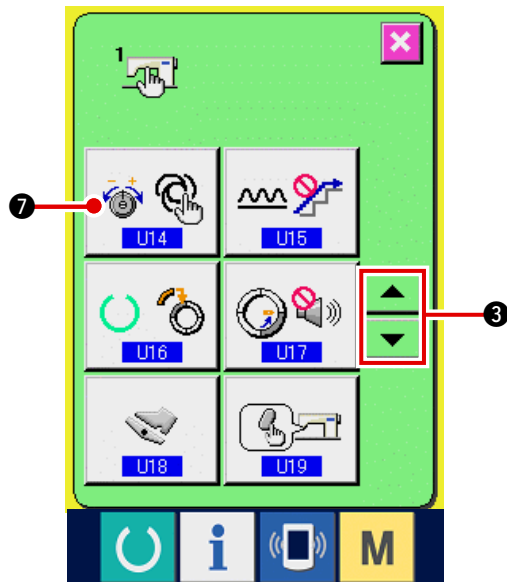

4) Determine the compensation tension automatic.

When ENTER button  ⑥ is pressed, the compensation tension mode selection screen is closed and selection of the compensation tension mode is completed. And, the screen returns to the memory switch list screen.



5) Select **U14 Compensation tension automatic setting.**

Press UP/DOWN SCROLL buttons 

 **3** to select **U14 Compensation thread tension automatic button**  **7**.

Compensation tension mode selection screen is displayed.

6) **Set the compensation thread tension automatic value.**

1. Press SHIRring AMOUNT RANGE SETTING button  **8** of LV.1 to input the upper limit of the shirring amount range of LV. 1 with ten keys **17**.

2. Next, press COMPENSATION THREAD TENSION SETTING button  **9** of LV.1 to input the compensation thread tension value of LV. 1 with ten keys **17**.

Similarly, input the value of LV.2, LV.3, LV.4 and LV.5 with buttons, **8** to **16**.

Setting example on the left-hand illustration is :

- In case shirring amount is - 4 to 5, compensation thread tension is - 3.
- In case shirring amount is 6 to 10, compensation thread tension is +5.
- In case shirring amount is 11 to 15, compensation thread tension is +11.
- In case shirring amount is 16 to 20, compensation thread tension is +21.
- In case shirring amount is 21 to 35, compensation thread tension is +28.

* When the setting is completed, press ENTER button  **18** to close the compensation tension automatic setting screen. And, the screen returns to the memory switch list screen.

* When MODE key **M** **19** is pressed, the data input screen is displayed.

* In case the compensation thread tension automatic is selected, even when STEP DETAILS SETTING button  **20** is pressed

and the step details screen is opened, the compensation thread tension setting button is not displayed.

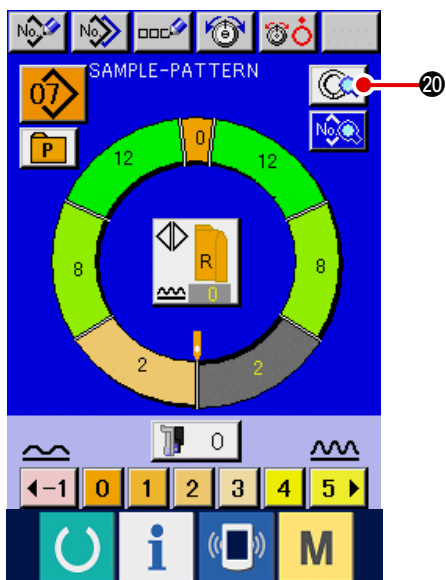
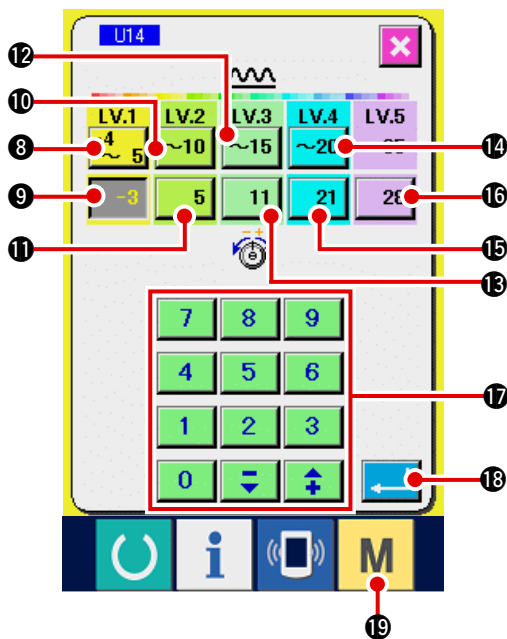

14-4 Explanation of the shirring smoothing function

The sewing machine is equipped with the smoothing function to control the sudden change of shirring amount at the time of changeover of the step. The value which is set here is reflected to each step of all pattern data.

(1) Explanation of the motion of shirring smoothing function

Motion of shirring smoothing function is explained below.

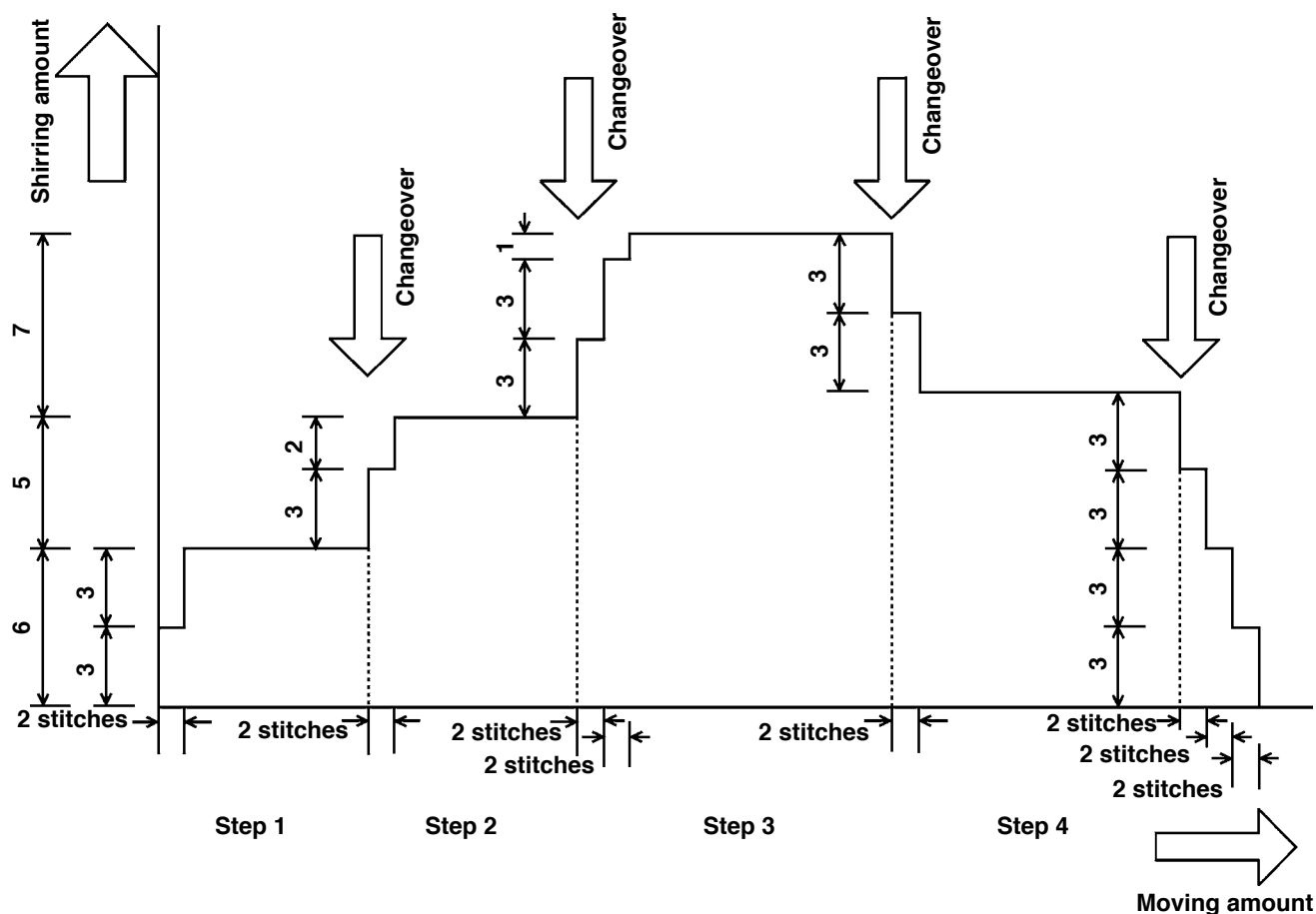

Example) When all steps are 4

- Smoothing function set value (Number of stitches) 2 stitches
(Shirring amount) 3

When the shirring amount of step 1 at the start of sewing is changed over to 6, first, the shirring amount is changed over to 3.

Next, after the motion of 2 stitches, the shirring amount is changed over to 6 (3+3).

When step 1 is changed to step 2, the shirring amount becomes 9 (6+3) immediately after the changeover and the shirring amount is changed over to 11 which has been set in step 2 after the motion of 2 stitches.

Hereafter, similarly, the shirring amount changes ± 3 at the time of changeover, further, the shirring amount changes ± 3 after the motion of 2 stitches, and the function performs the motion until the shirring amount which has been set in the step is reached.

- * When the fully-automatic mode is selected, the shirring amount in terms of the position of changeover is symmetrically divided in front and rear since the changeover of step is automatically performed.

(2) Setting of the shirring smoothing function

Setting procedure of the shirring smoothing function is explained.

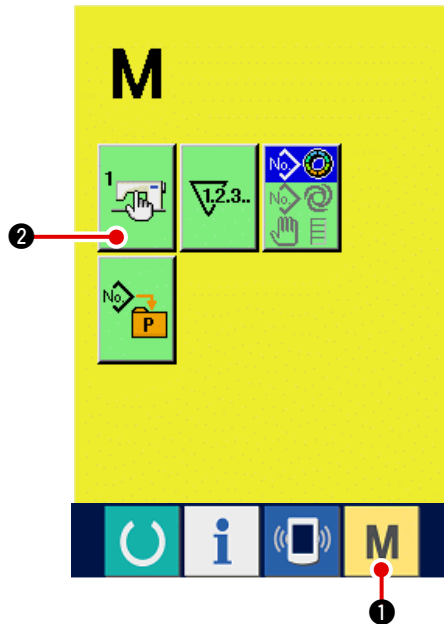

1) Display the memory switch list screen.

When MODE key **M** ① is pressed,

MEMORY SWITCH button  ② is displayed

on the screen. When this button is pressed, the memory switch list screen is displayed.

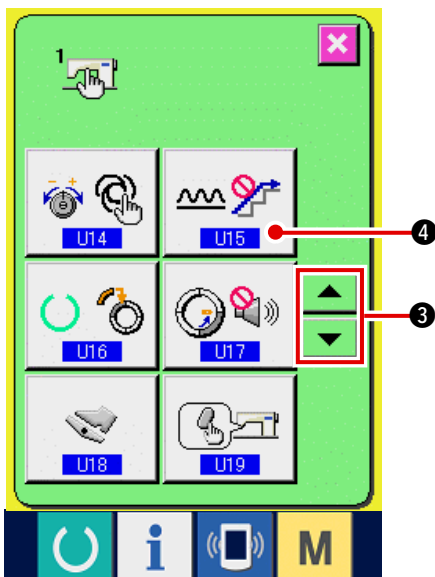

2) Select the shirring smoothing function.

Press UP/DOWN SCROLL button 

 ③ to select **U15** Shirring smoothing

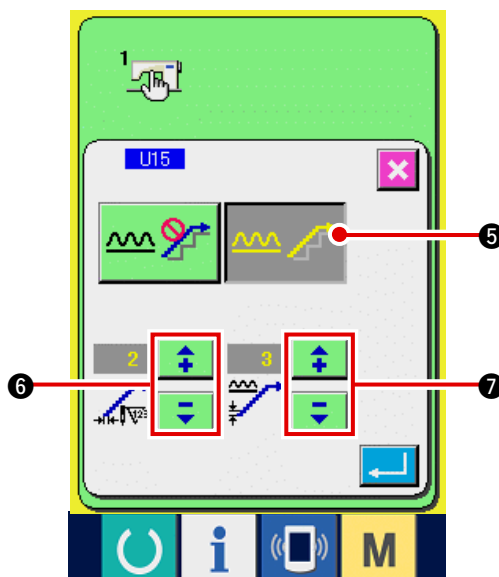

function selection button  ④. The shirring smoothing function selection screen is displayed.





3) Make the shirring smoothing function effective.

Select EFFECTIVE button  ⑤.

4) Set the number of stitches of shirring smoothing function.

Press   ⑥ buttons to input the number of stitches of shirring smoothing function.

5) Set the shirring amount of shirring smoothing function.

Press   ⑦ buttons to input the shirring amount of shirring smoothing function.

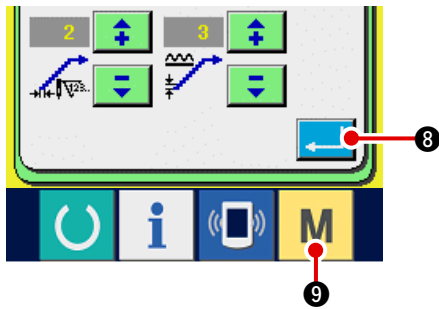

6) Determine the setting of shirring smoothing function.

When ENTER button  ⑧ is pressed, the shirring smoothing function setting screen is closed and the setting is determined. And, the screen returns to the memory switch list screen.

When MODE key  ⑨ is pressed, the data input screen is displayed.

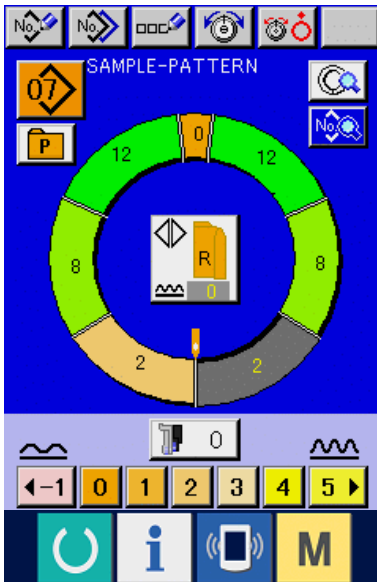

14-5 Explanation of the size class

When the fully-automatic mode is selected, it is possible to perform the setting of country class, basic size, and gents'/ladies' at the time of creating a new pattern, the size display at the time of grading changes according to the country class which has been set here.





The value which is set here is the value which becomes the initial value when creating a pattern. Even when the value here is changed, the contents of the pattern which has been already created do not change. However, only when the size country class is changed, the display of size changes.

(1) Explanation of the size class

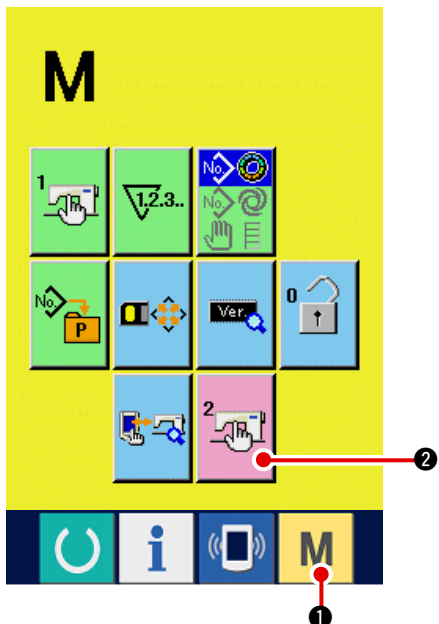
Setting procedure of the size class is explained here.



1) Display the memory switch list screen.

When MODE key  ① is held pressed more than 6 seconds, MEMORY SWITCH button  ② is displayed on the screen. When this button is pressed, the memory switch list screen is displayed.

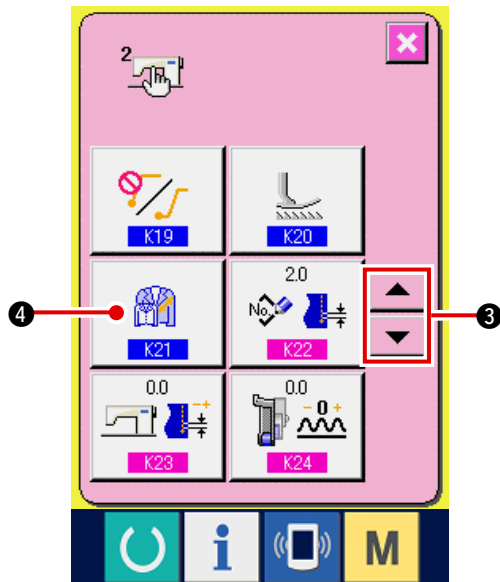

2) Select **K21** Size class.

Press UP/DOWN SCROLL buttons



 3 to select **K21** Size class setting

button  4. The size class setting screen is displayed.

3) Select the size of country class.

 1 (Germany) Ladies

 2 (Germany) Girls

 (France)

 (Italy)



 (America)

 (Japan)

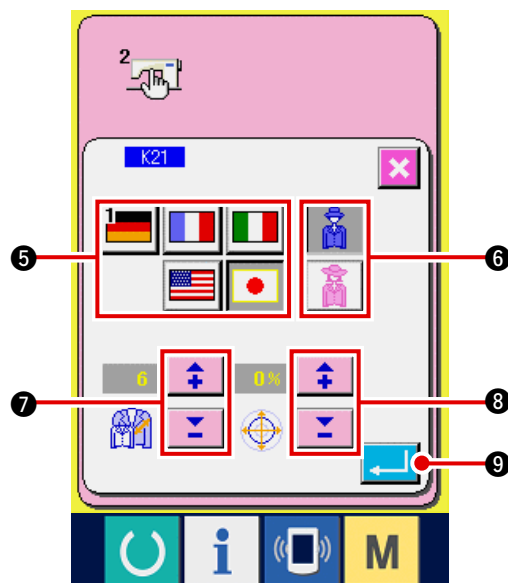

Select the size from buttons 5.





4) Select gents'/ladies' wear.

Press   buttons 6 to select gents'/ladies' wear.

5) Set the basic size.

Press   buttons 7 to input the basic size. For the size of country class, refer to the size development.

6) Set the grading ratio (%).

Press   buttons 8 to input the grading ratio. The inputted ratio (%) becomes the offset value of the grading for each step when a new pattern is created.

7) Determine the size class setting.



When ENTER button  9 is pressed, the size class setting screen is closed and the setting is determined. And, the screen returns to the memory switch screen.







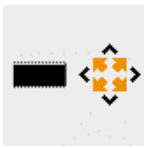
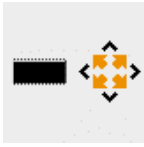
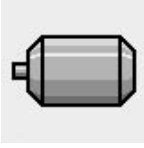
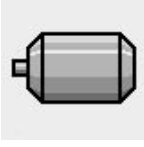
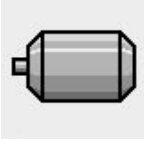
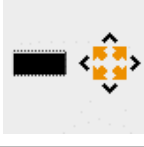
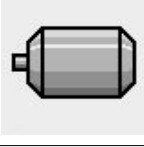
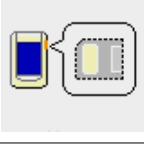

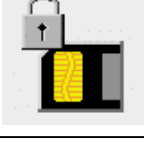
(2) Size development



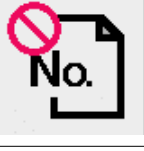
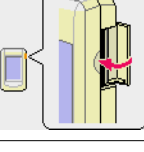
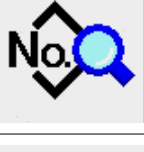
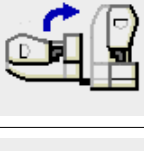



Size development for the respective country classes is shown below.



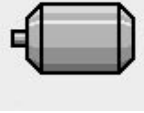
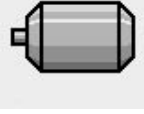

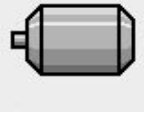
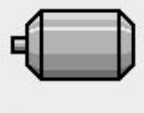
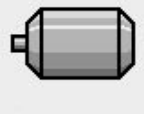
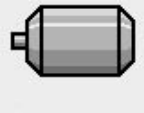

										
										
32	104	34	36	06	03	44	44	34	34	02
34	110	36	38	08	05	46	46	36	36	03
36	116	38	40	10	07	48	48	38	38	04
38	122	40	42	12	09	50	50	40	40	05
40	128	42	44	14	11	52	52	42	42	06
42	134	44	46	16	13	54	54	44	44	07
44	140	46	48	18	15	56	56	46	46	08
46	146	48	50	20	17	58	58	48	48	09
48	152	50	52	22	19	60	60	50	50	10
50	158	52	54	24	21	62	62	52	52	11
52	164	54	56	26	23	64	64	54	54	12
54	170	56	58	28	25	66	66	56	56	13
56	176	58	60	30	27	68	68	58	58	14
58	182	60	62	32	29	70	70	60	60	15
60	188	62	64	34	31	72	72	62	62	16

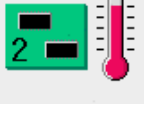
15. ERROR CODE LIST

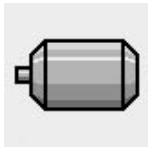
Error code	Pictograph	Description of error	How to recover	Place of recovery
E000		Contact of initialization of main shaft EEPROM of MAIN p.c.b. When data is not written in EEPROM or data is broken, data is automatically initialized and the initialization is informed.	Turn OFF the power.	
E001		Contact of initialization of main EEPROM of MAIN p.c.b. When data is not written in EEPROM or data is broken, data is automatically initialized and the initialization is informed.	Turn OFF the power.	
E003		Main shaft motor encoder defectiveness Angle counter of needle UP detection has exceeded the value equivalent to 1.1 turns. Angle counter of needle DOWN detection has exceeded the value equivalent to 1.1 turns.	Turn OFF the power.	
E004		Main shaft motor needle DOWN detection defectiveness Angle counter of needle UP detection has not exceeded the value equivalent to 1.1 turns. Angle counter of needle DOWN detection has exceeded the value equivalent to 1.1 turns.	Turn OFF the power.	
E005		Main shaft motor needle UP detection defectiveness Angle counter of needle UP detection has exceeded the value equivalent to 1.1 turns. Angle counter of needle DOWN detection has exceeded the value equivalent to 1.1 turns.	Turn OFF the power.	
E006		Contact of initialization of machine head EEPROM of the circuit board mounted on the machine head When data is not written in EEPROM or data is broken, data is automatically initialized and the initialization is informed.	Turn OFF the power.	
E007		Main shaft motor-lock When large needle resistance sewing product is sewn	Turn OFF the power.	
E011		External media not inserted External media is not inserted.	Possible to recover by reset.	Previous screen
E012		Read error Data read from external media cannot be performed.	Possible to recover by reset.	Previous screen
E013		Write error Data write from external media cannot be performed.	Possible to recover by reset.	Previous screen
E014		Write protect External media is in the write prohibition state	Possible to recover by reset.	Previous screen

Error code	Pictograph	Description of error	How to recover	Place of recovery
E015		Format error Format cannot be performed.	Possible to recover by reset.	Previous screen
E016		External media capacity over Capacity of external media is short.	Possible to recover by reset.	Previous screen
E022		File No. error Designated file is not in smart media.	Possible to recover by reset.	Previous screen
E029		Smart media error Lid of smart media slot is open.	Possible to recover by reset.	Previous screen
E062		Sewing data error When sewing data is broken or revision is old.	Turn OFF the power.	
E302		Confirmation of tilt of machine head When tilt of machine head sensor is OFF.	Turn OFF the power.	
E303		Main shaft semilunar plate sensor error Semilunar plate of sewing machine motor is abnormal.	Turn OFF the power.	
E702		Abnormality of control CPU performed processing other than supposed.	Turn OFF the power.	
E703		Panel is connected to the machine other than supposed. (Machine type error) When machine type code of system is improper in case of initial communication.	Possible to rewrite program after pressing down communication switch.	Communication screen
E704		Nonagreement of system version When version of system software is improper in case of initial communication.	Possible to rewrite program after pressing down communication switch.	Communication screen
E731		Main motor hole sensor defectiveness or position sensor defectiveness When motor hole sensor error signal (UVWE) is detected with the motor locked (2 seconds or more have passed at 20 rpm or less).	Turn OFF the power.	

Error code	Pictograph	Description of error	How to recover	Place of recovery
E733		Reverse rotation of main shaft motor When motor has continued to rotate 40 times or more in the reverse direction as against the control direction at 500 rpm or more during motor running (excluding at the time of holding).	Turn OFF the power.	
E801		Phase-lack of power When 400 ms or more of power phase-lack signal (PHE) is detected after 2 seconds of phase-lack observation invalid time passed from turning ON the power.	Turn OFF the power.	
E802		Power instantaneous cut detection When power instantaneous cut detection signal (PWF) is detected.	Turn OFF the power.	
E810		Solenoid power short-circuit When solenoid power short-circuit signal (PWSH) (CPLD internal signal) is detected while power phase-lack signal (PHE) is not detected after 2 seconds of phase-lack observation invalid time passed from turning ON the power.	Turn OFF the power.	
E811		Overvoltage When power overvoltage signal (OVL) which is output when input power is 280V or more is detected.	Turn OFF the power.	
E813		Low voltage When low voltage signal (LVL) which is output when input power is 150V or less is detected.	Turn OFF the power.	
E903		Abnormality of stepping motor power When stepping motor power abnormality signal (LVPMP) which is output when the stepping motor power, 48V, fluctuates -15% or more when turning ON the power is detected.	Turn OFF the power.	
E915		Abnormality of communication between operation panel and main CPU When abnormality occurs in data communication.	Turn OFF the power.	
E916		Abnormality of communication between main CPU and main shaft CPU When abnormality occurs in data communication.	Turn OFF the power.	
E917		Failure of communication between operation panel and personal computer When abnormality occurs in data communication.	Possible to recover by reset.	Previous screen
E918		Abnormality of heat sink temperature for MAIN p.c.b. When temperature of heat sink for MAIN p.c.b. is 85°C or more.	Turn OFF the power.	

Error code	Pictograph	Description of error	How to recover	Place of recovery
E920		CPLD writing abnormality When 1 bit each is written in the test port and it does not agree with Verfy when turning ON the power.	Turn OFF the power.	
E922		Main shaft motor control impossible When the number of rotation of measuring exceeds 50 ms or more than the upper limit value (3,500 rpm).	Turn OFF the power.	
E924		Main shaft drive trouble When motor driver error signal (GTRE) is detected while motor overcurrent signal (OCL1) is not detected with the motor locked (2 seconds or more have passed at 20 rpm or less).	Turn OFF the power.	
E941		CPLD reading abnormality When input signal from CPLD is read twice and they do not agree with each other even when trying 10 ms or more when turning ON the power.	Turn OFF the power.	
E942		Main shaft EEPROM trouble When data writing to EEPROM cannot be performed.	Turn OFF the power.	
E943		Main EEPROM trouble When data writing to EEPROM cannot be performed.	Turn OFF the power.	
E946		Head EEPROM trouble When data writing to EEPROM cannot be performed.	Turn OFF the power.	



16. USING COMMUNICATION FUNCTION

Communication function can download the sewing data created with other sewing machine, creation of sewing data and sewing data created by editing device PM-1 to the sewing machine. In addition, the function can upload the aforementioned data to the smart media or personal computer.

Smart media and RS-232C port are prepared as the vehicle to communicate.

16-1 Handling possible data

Handling possible sewing data are two kinds below. The respective data formats are as described below.

Data name	Pictograph	Extension	Description of data
Vector format data		VD00 △ △ △ .vdt	Data of the needle entry point created with PM-1 Format of the data which can be used in common among JUKI sewing machines.
Parameter data		DP00 △ △ △ .epd	Format of the data of sewing proper to DP such as number of steps, length of step, shirring amount, thread tension value, etc. created with the sewing machine

△ △ △ : file No.

In case of saving the data in the smart media, save the data in the state of directory structure below. When the data are not saved in the correct folder, reading of file cannot be performed.

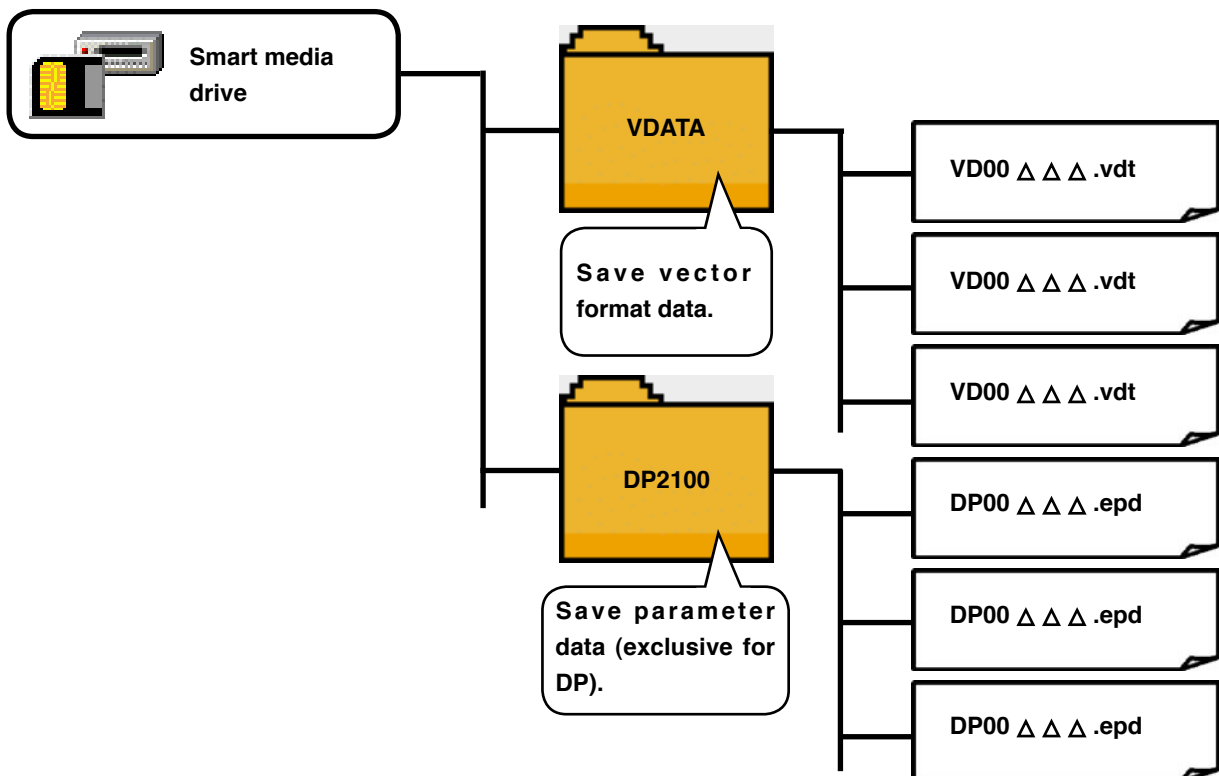

There is beforehand the PROG folder in the Smart media purchased from our company. Do not delete it.

16-2 Performing communication by using the smart media

[Setting procedure]

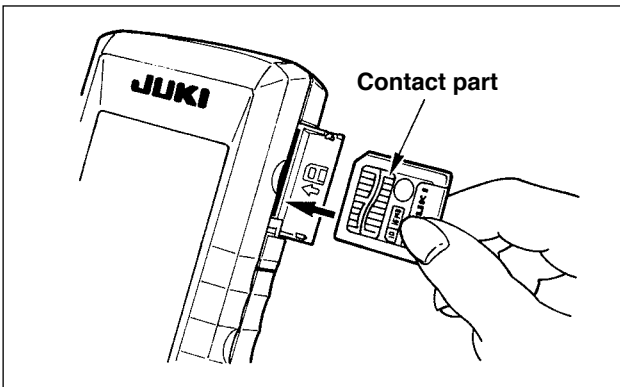

- 1) When the upper side cover located on the side of the operation panel is opened, there is the inserting opening for smart media card. Put the contact part of the card to the front side and insert it into the opening.

- 2) The smart media card stops once in the protruding state by approximately 10 mm while inserting the card. Further, apply force to insert the card and ease up the force when it is reached to the end. Setting is completed when the card has returned by approximately 1 mm.

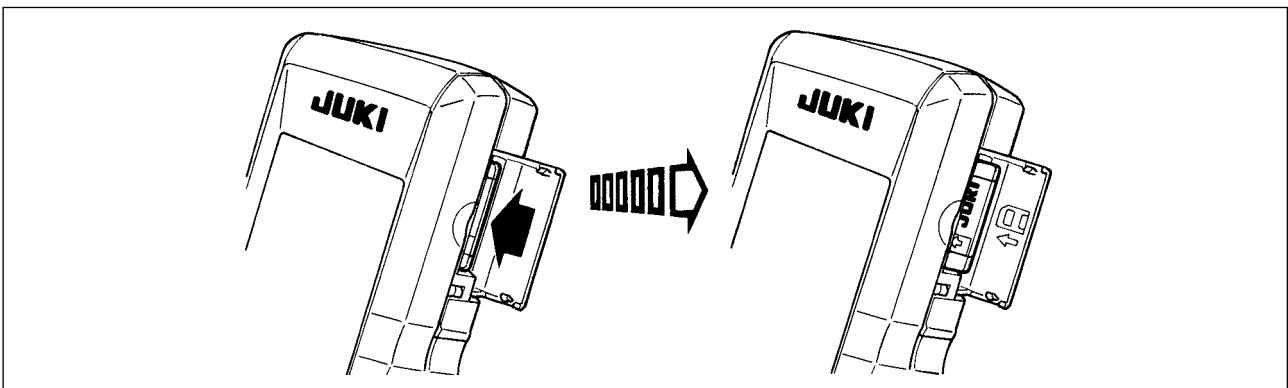

- 3) After completion of setting of the card, close the smart media cover. By closing the cover, it is possible to perform communication. If the smart media card and the cover come in contact with each other and the cover is not closed, check the following matters.

- Check that the inserting is stopped in the state that the card protrudes by approximately 10 mm.
- Check that the contact part of the card is put downward and inserted.
- Check that the smart media card other than 3.3V voltage type is used.

[Removing procedure]

- 1) Open the smart media cover, push the card until it goes no further, and ease up force when it goes to the end. The card returns by approximately 10 mm in the reverse order of the time of setting.

- 2) Then draw out the card to complete removing.

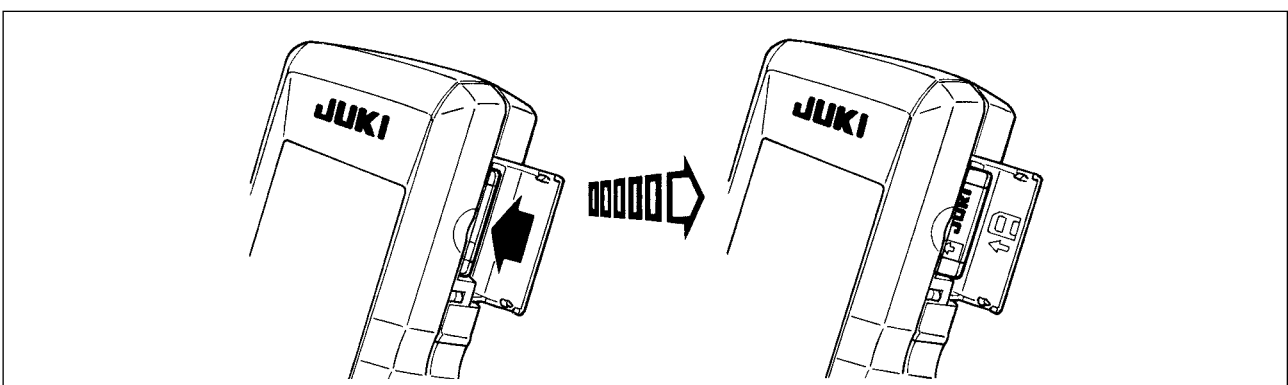

[Performing format]

In case of re-formatting the smart media, be sure to perform it with IP-200. The smart media formatted with the personal computer cannot be read with IP-200.

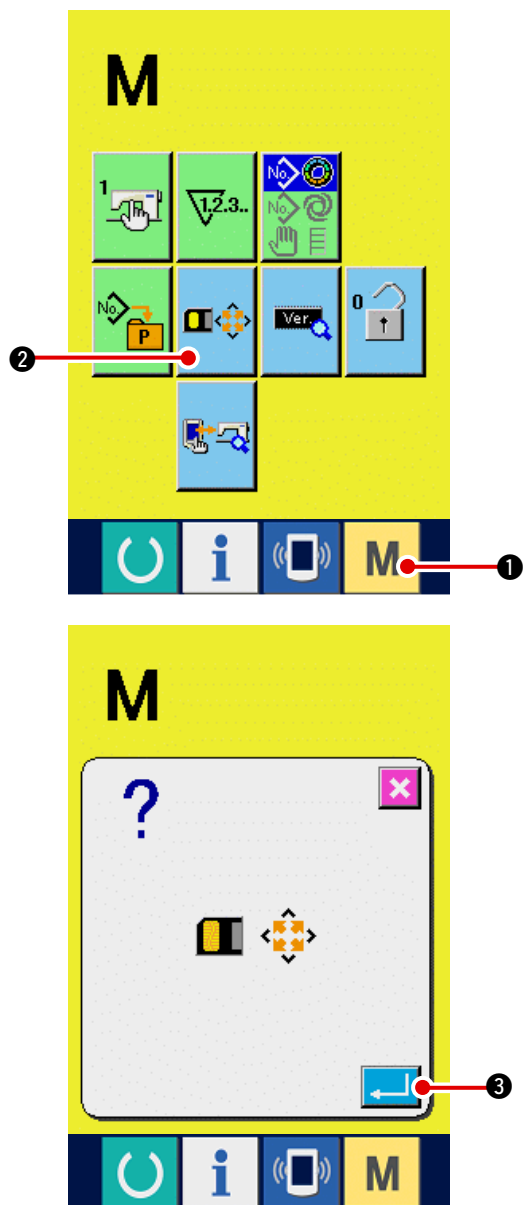

1) Display the smart media format screen.

When **M** ① switch is held pressed for three seconds, smart media format button  ② is displayed on the screen. When this button is pressed, the smart media format screen is displayed.

2) Start formatting of the smart media.

Set the smart media you desire to format to the smart media slot, close the cover, press ENTER button  ③ and formatting starts.



Caution Save necessary data in the smart media to the other vehicle before formatting. When formatting is performed, the inside data are deleted.

[Prohibition items in handling the smart media]

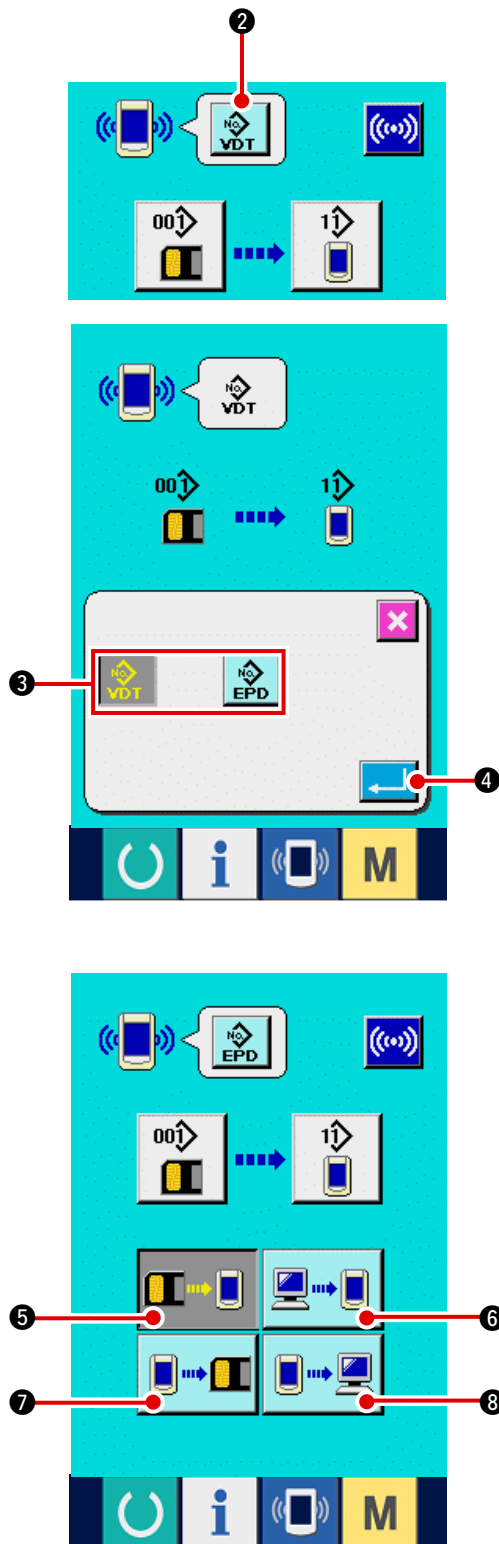
- ① Smart media is a precision electronic instrument. Do not bend it or apply shock to it.
- ② It is recommended to periodically save the data saved in the smart media to the other vehicle to prepare for accidents.
- ③ When initializing the data, perform it after checking that necessary data do not exist in the card.
- ④ Avoid using or storing the smart media in a place of high temperature and high humidity.
- ⑤ Avoid using the smart media near exothermic and combustible articles.
- ⑥ If the contact part of the card becomes dirty, failure of contact will be caused. Do not touch by hand, and control so that dust, oil, or other foreign material does not adhere to it. In addition, the inside element is damaged by static electricity or the like. So, be very careful when handling.
- ⑦ Smart media has a span of life. Writing and deletion cannot be performed after an extended period of use. In this case, replace it with a new one.



2) Select the kind of data.





When data selection button  (2) is pressed, the data selection screen is displayed. Select button   (3) of kind of data to be communicated. The selected button is displayed in reverse video.

3) Determine the kind of data.



When ENTER button  (4) is pressed, the kind of data selection screen is closed and the selection of the kind of data has been completed.

4) Select the communication procedure.

There are four communication procedures as described below.

-  (5) Writing data from smart media to panel
-  (6) Writing data from personal computer (server) to panel
-  (7) Writing data from panel to smart media
-  (8) Writing data from panel to personal computer (server)

Select the button of communication procedure you desire.

- * When the vector format data  (2) is selected in the kind of data, it cannot be selected to write the data to the smart media from  (7) panel, and to write the data to personal computer (server) from  (8) panel.

Vector format data is converted to the parameter data at the time of writing the data to the panel.

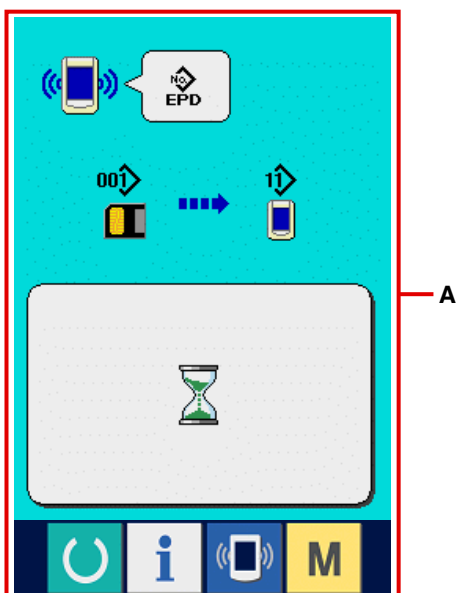
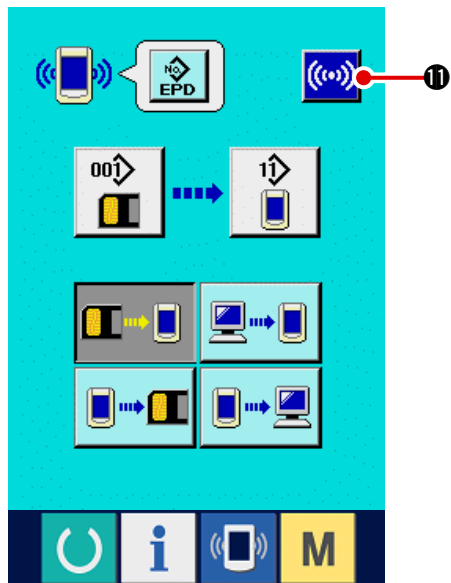
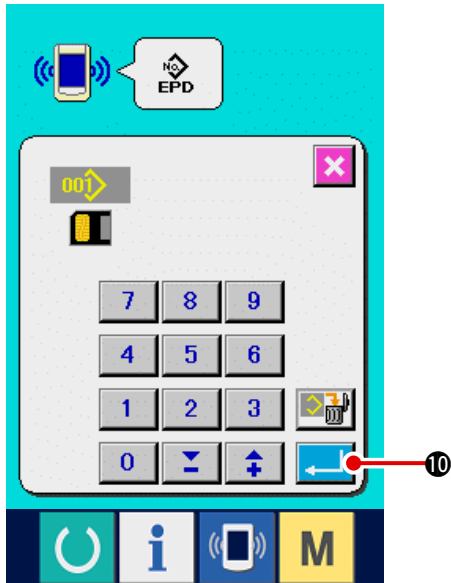
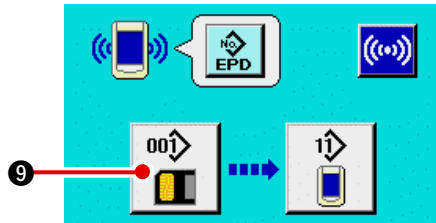

5) Select the data No.

When  9 is pressed, the writing file selection screen is displayed.

Input the file No. of the data you desire to write. For the file No., input the numerals of the part $\Delta \Delta$ of VD00 $\Delta \Delta \Delta$.vdt of the file name. Designation of the pattern No. of writing destination can be performed in the same way. When the writing destination is the panel, pattern Nos. which have not been registered are displayed.

6) Determine the data No.

When ENTER button  10 is pressed, the data No. selection screen is closed and the selection of the data No. has been completed.

7) Start communication.

When communication button  11 is pressed, the data communication starts. The communication screen **A** is displayed during communication and the screen returns to the communication screen after the end of communication.

* Do not open the cover during reading the data. Data may not be read in.

17. INFORMATION FUNCTION

There are three functions below in the information function.

- 1) Oil replacement (grease-up) time, needle replacement time, cleaning time, etc. can be specified and the warning notice can be performed after the lapse of the specified time.
Refer to "[17-1 Observing the maintenance and inspection information](#)" and "[17-2 Inputting the maintenance and inspection time](#)".
- 2) Speed can be checked at a glance and the target achieving consciousness as a line or group is increased as well by the function to display the target output and the actual output.
Refer to "[17-4 Observing the production control information](#)" and "[17-5 Performing setting of the production control information](#)".
- 3) Information on machine working ratio, pitch time, machine time and machine speed can be displayed from the working state of the sewing machine.
Refer to "[17-6 Observing the working measurement information](#)".

17-1 Observing the maintenance and inspection information

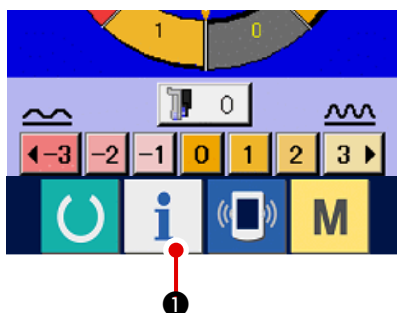

1) Display the information screen.

When information key  ① of the switch seat section is pressed in the data input screen, the information screen is displayed.

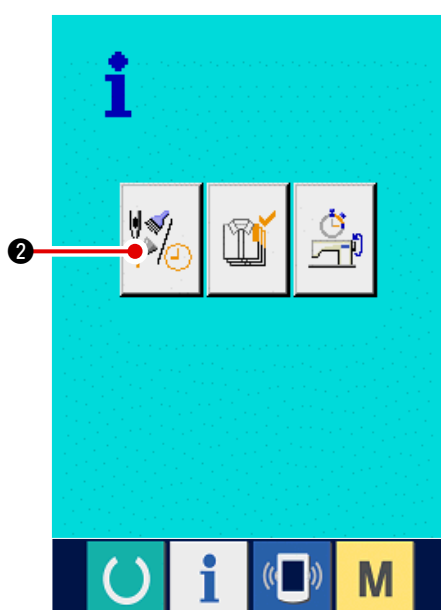

2) Display the maintenance and inspection information screen.

Press maintenance and inspection informationscreen display button  ② in the information screen.

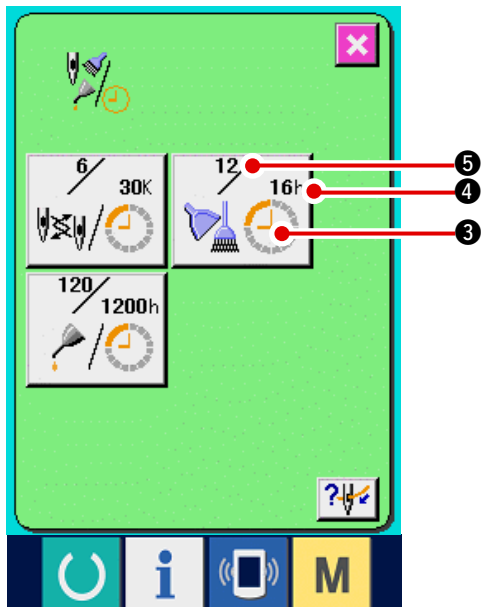

Information on the following three items is displayed in the maintenance and inspection information screen.

- Needle replacement :
(1,000 stitches)

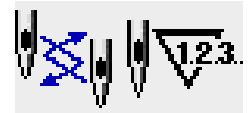

- Cleaning time (hour) :



- Oil replacement time (hour) :
(Grease-up time)



The interval to inform of the inspection for each item in button **3** is displayed at **4**, and remaining time up to the replacement is displayed at **5**. In addition, remaining time up to the replacement can be cleared.

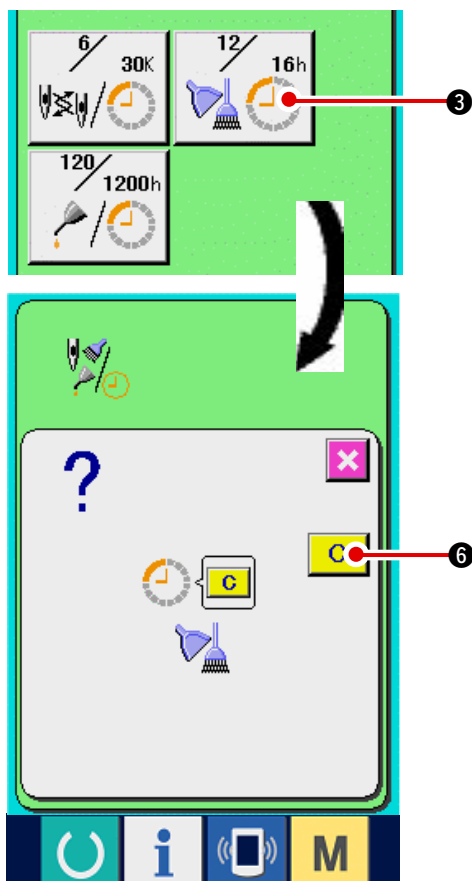

3) Perform clearing remaining time up to the replacement.

When button **3** of the item you desire to clear is pressed, the time of replacement clear screen is displayed. When CLEAR button **C** **6** is pressed, the remaining time up to the replacement is cleared.

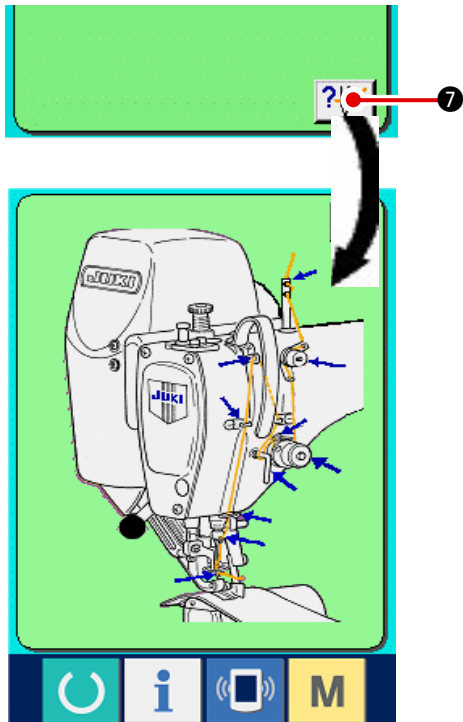

4) Display the threading diagram.

When threading button  ⑦ displayed in the maintenance and inspection screen is pressed, the needle thread threading diagram is displayed. Observe it when performing threading.

17-2 Inputting the inspection time

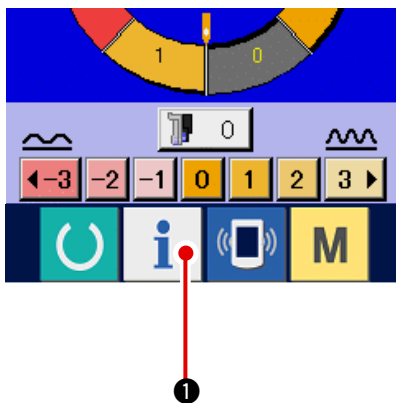

1) Display the information screen (maintenance personnel level).

When information key  ① of the switch seat section is pressed in the data input screen for approximately three seconds, information screen (maintenance level) is displayed. In case of the maintenance personnel level, the pictograph located on the upper left side changes from blue to orange, and five buttons are displayed.

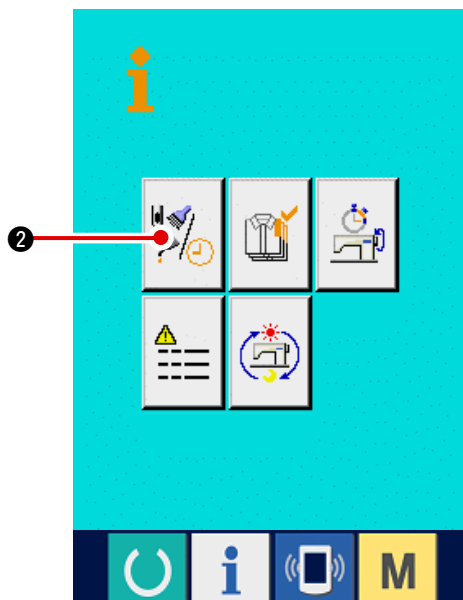

2) Display the maintenance and inspection information screen.

Press maintenance and inspection information screen display button  ② in the information screen.

* For the two buttons displayed in the bottom stage at the time of the maintenance personnel level, refer to ["23 DInformation screen of the maintenance personnel level"](#).

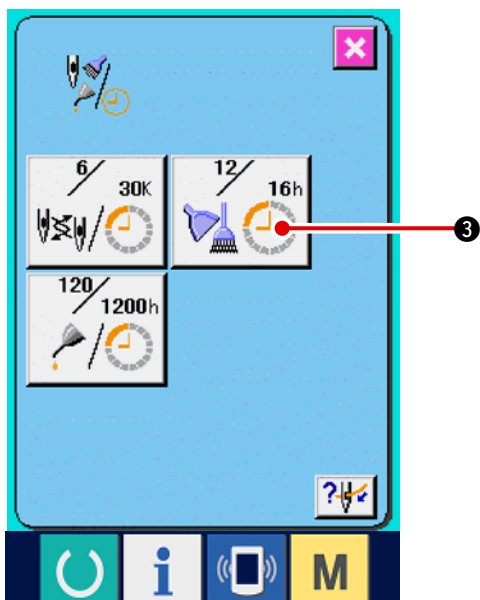

The same information as that in the normal maintenance and inspection information screen is displayed in the maintenance and inspection information screen.

When button ③ of the item you desire to change the inspection time is pressed, the inspection time input screen is displayed.

3) Input the inspection time.

Input the inspection time.

When the inspection time is set to "0", the warning function stops.

When clear button **C** ④ is pressed, the value returns to the initial value.

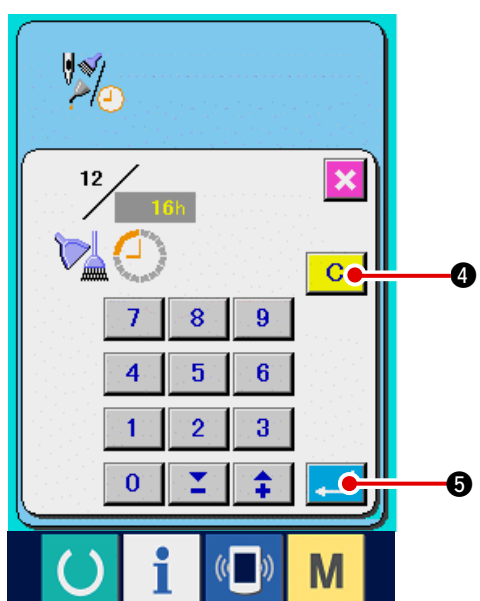

The initial values of the inspection time of respective items are as follows.

- Needle replacement : 0 (1,000 stitches)
- Cleaning time : 0 (hour)
- Oil replacement time : 1,028 (hour)
(Grease-up time)

* Grease-up time is the time that 30 days/month, 5 days/week and 8 hours/day are converted to 6 months.

The calculating method is $\left(\frac{30 \text{ days} \times 6 \text{ months}}{7 \text{ days}} \right) \times 5 \text{ days} \times 8 \text{ hours}$.

When ENTER **↵** ⑤ button is pressed, the inputted value is determined.

17-3 Releasing procedure of the warning

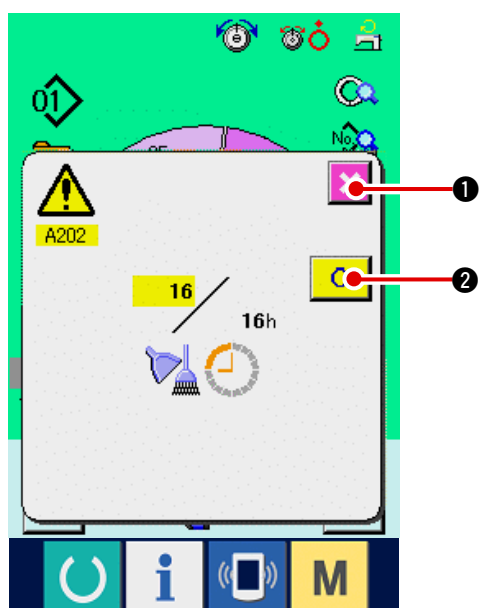

When the designated inspection time is reached, the warning screen is displayed.

In case of clearing the inspection time, press CLEAR button **C** ②. The inspection time is cleared and the pop-up is closed. In case of not clearing the inspection time, press CANCEL button **X**

① and close the pop-up. Every time one sewing is completed, the warning screen is displayed until the inspection time is cleared.

Warning Nos. of the respective items are as follows.

- Needle replacement : A201
- Cleaning time : A202
- Oil replacement time : A203
(Grease-up time)

17-4 Observing the production control information

It is possible to designate the start, display the number of pieces of production from the start to the existing time, display the number of pieces of production target, etc. in the production control screen.

There are two kinds of display ways for the production control screen.

(1) When displaying from the information screen

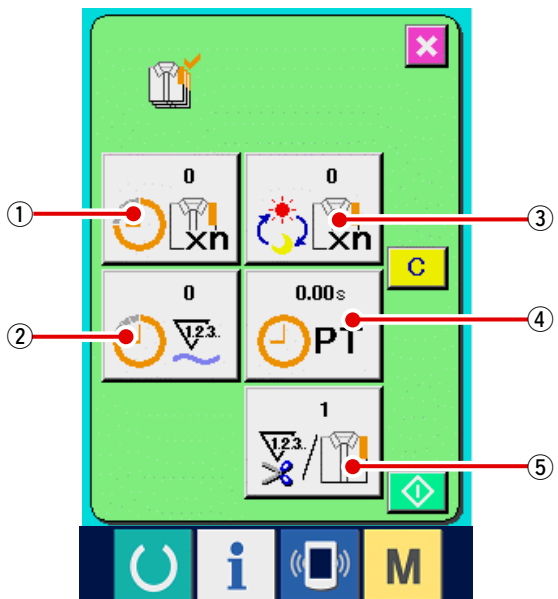
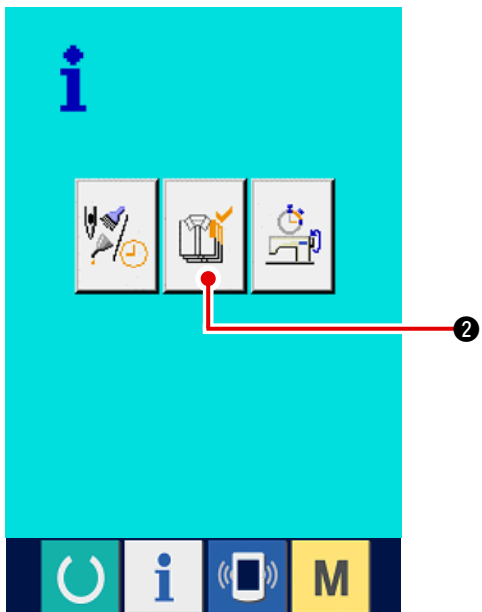
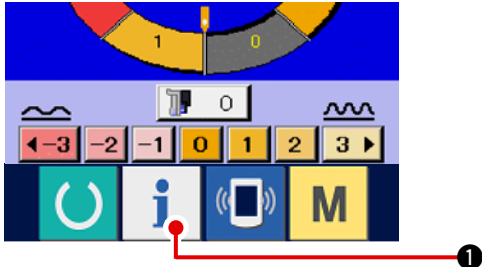

1) Display the information screen.

When information key  ① of the switch seat section is pressed in the data input screen, the information screen is displayed.

2) Display the production control screen.

Press production control screen display button  ② in the information screen. The production control screen is displayed.

Information on the following 5 items is displayed in the production control screen.

- ① : Existing target value
Number of pieces of the target of products at the present time is automatically displayed.
- ② : FActual results value
Number of pieces of the sewn products is automatically displayed.
- ③ : Final target value
Number of pieces of the final target of products is displayed. Input the number of pieces referring to ["17-5 Performing setting of the production control information"](#).
- ④ : Pitch time
Time (second) required for one process is displayed. Input the time (unit : second) referring to ["17-5 Performing setting of the production control information"](#).
- ⑤ : Number of times of thread trimming
Number of times of thread trimming per process is displayed. Input the number of times referring to ["17-5 Performing setting of the production control information"](#).

(2) When displaying from the sewing screen

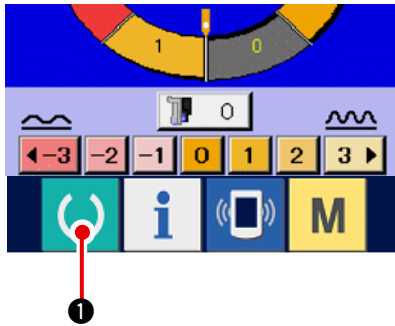

1) Display the sewing screen.

When READY key  ① of the switch seat section is pressed in the data input screen, the sewing screen is displayed.

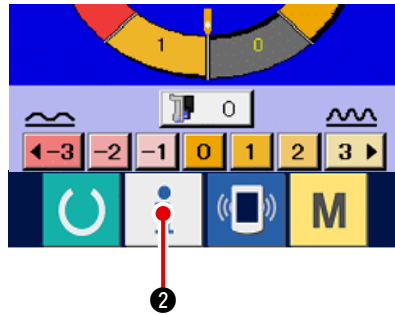

2) Display the production control screen.

When information key  ② of the switch seat section is pressed in the sewing screen, the production control screen is displayed.

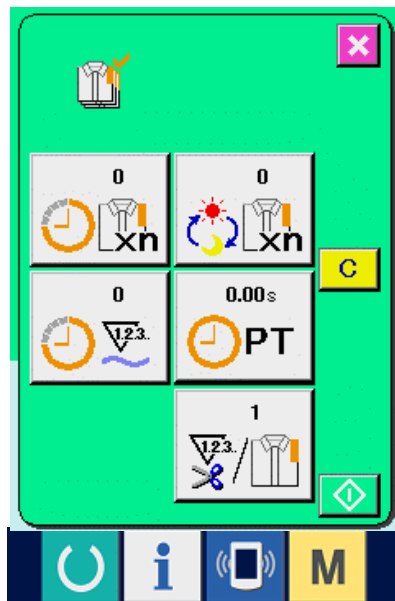

The contents of display and the functions are common to ["17-4 \(1\) When displaying from the information screen"](#).

17-5 Performing setting of the production control information

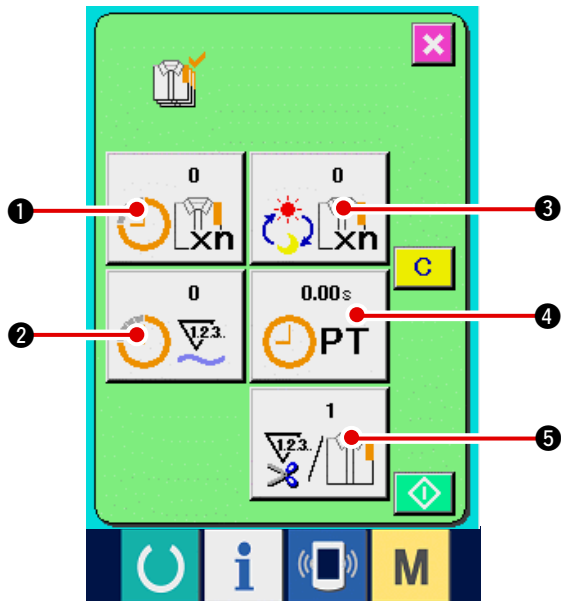

1) Display the production control screen.

Display the production control screen referring to "[17-4 Observing the production control information](#)".

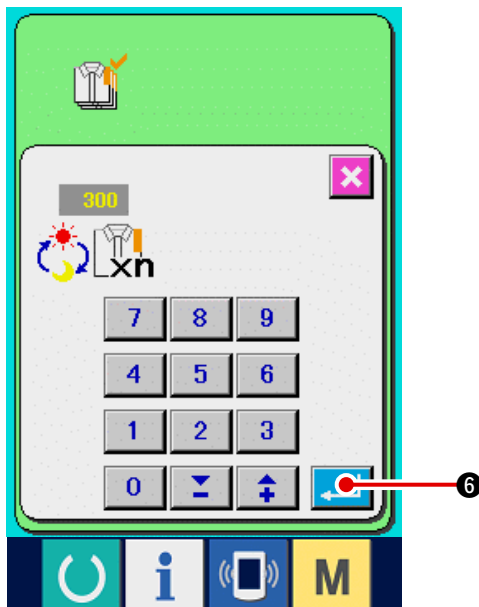

2) Input the final target value.

First, input the number of pieces of the target of production in the process to which sewing is performed from now on. When final target value button  ③ is pressed, the final target value input screen is displayed.

Input the value you desire with ten keys or UP/DOWN buttons.

After the input, press ENTER button  ⑥.

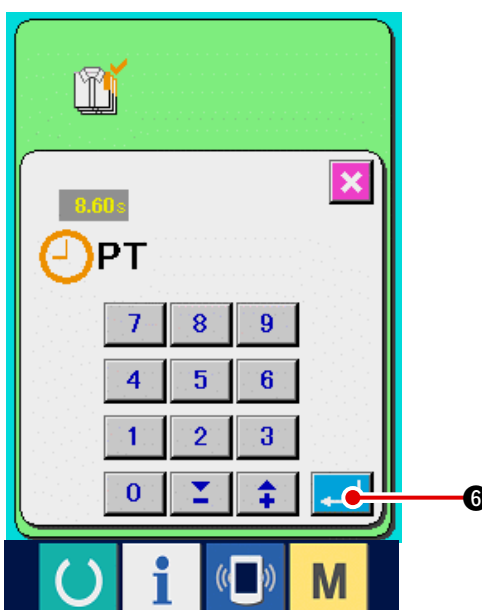

3) Input the pitch time.

Next, input the pitch time required for one

process. When PITCH button  ④ of the aforementioned item 1) is pressed, the pitch time input screen is displayed.

Input the value you desire with ten keys or UP/DOWN buttons.

After the input, press ENTER button  ⑥.

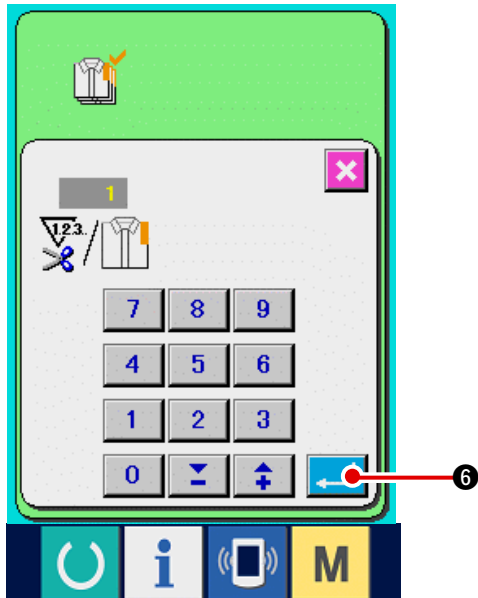

4) **Input the number of times of thread trimming.**
Next, input the number of times of thread trimming per process.

When number of times of thread trimming button  5 in the previous page is pressed, the number of times of thread trimming input screen is displayed.

Input the value you desire with ten keys or UP/DOWN buttons.

After the input, press ENTER button  6.

* **When the input value is "0", count of the number of times of thread trimming is not performed. Use this function by connecting the external switch.**

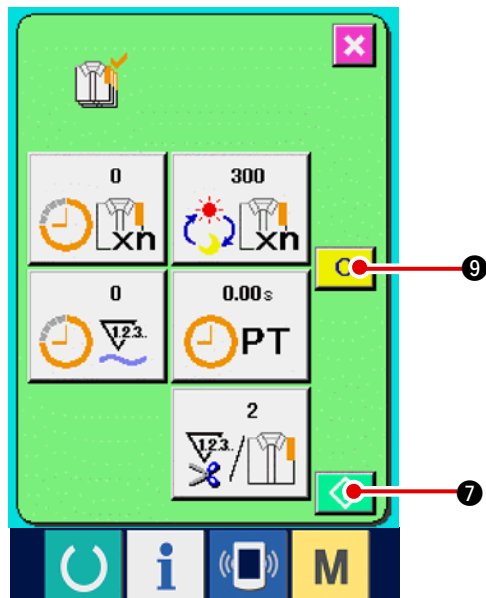



5) **Start the count of number of pieces of production.**

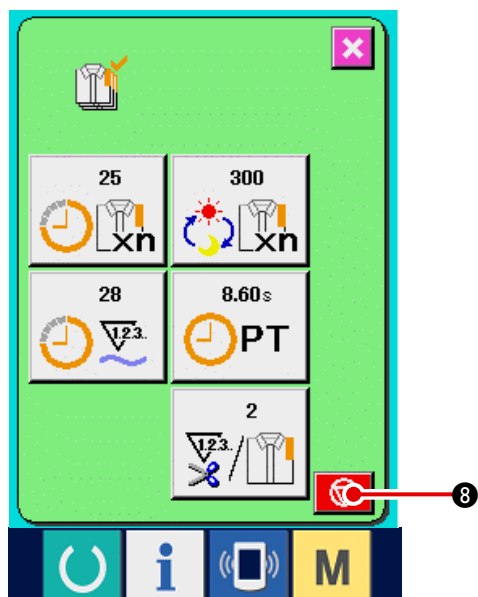

When START button  7 is pressed, the count of number of pieces of production is started.



6) **Stop the count.**

Display the production control screen referring to "[17-4 Observing the production control information](#)".

When the count is being performed, STOP switch  8 is displayed. When STOP button  8 is pressed, the count is stopped.

After the stop, START button  7 is displayed at the position of STOP button. When continuing the count, press START button again. The counted value is not cleared until CLEAR button  9 is pressed.

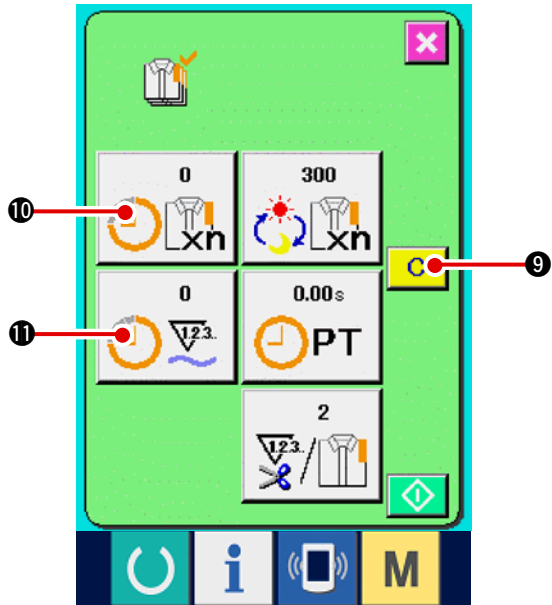

7) Clear the counted value.

When clearing the counted value, set the count to the stop state and press CLEAR button **C**

9.

The value to be cleared is the present target value 10 and actual results value 11 only.

(Note)

CLEAR button is displayed only in case of stop state.

When CLEAR button is pressed, the clear confirmation screen is displayed.

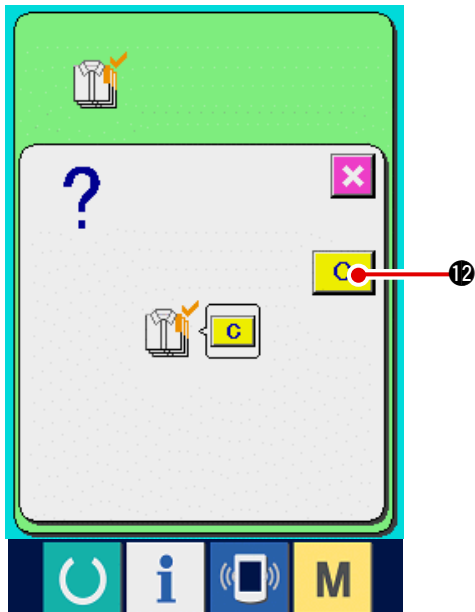

When CLEAR button **C** 12 is pressed in the clear confirmation screen. the counted value is cleared.

17-6 Observing the working measurement information

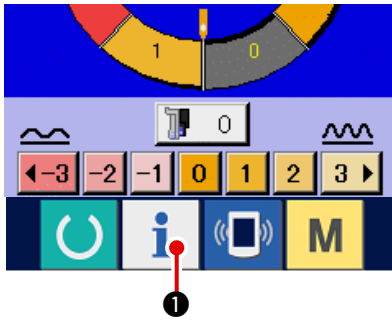

1) Display the information screen.

When information key  ① of the switch seat section is pressed in the data input screen, the information screen is displayed.

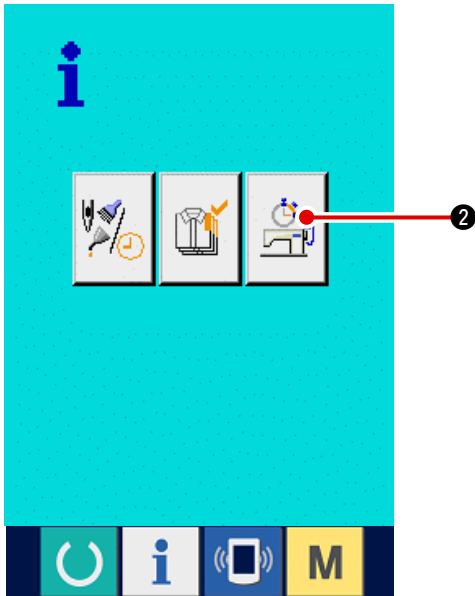

2) Display the working measurement screen.

Press working measurement screen display button  ② in the information screen. The working measurement screen is displayed.

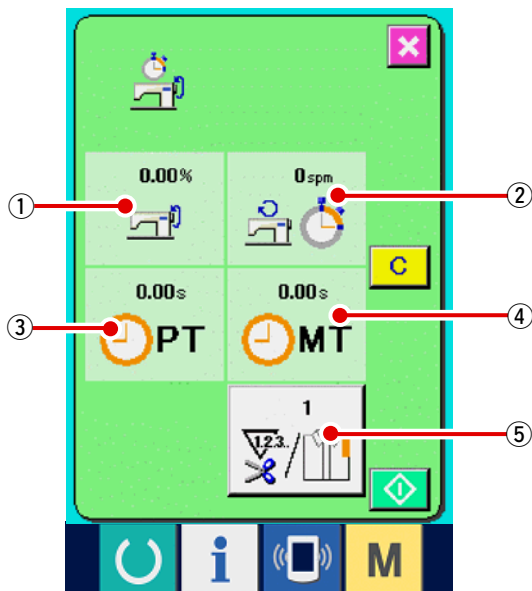

Information on the following 5 items are displayed in the working measurement screen.

- ① : The information is automatically displayed from the time of start of measuring the working ratio.
- ② : The information is automatically displayed from the time of start of measuring the machine speed.
- ③ : The information is automatically displayed from the time of start of measuring the pitch time.
- ④ : The information is automatically displayed from the time of start of measuring the machine time.
- ⑤ : Number of times of thread trimming is Input the number of times referring to item 3) on the next page.

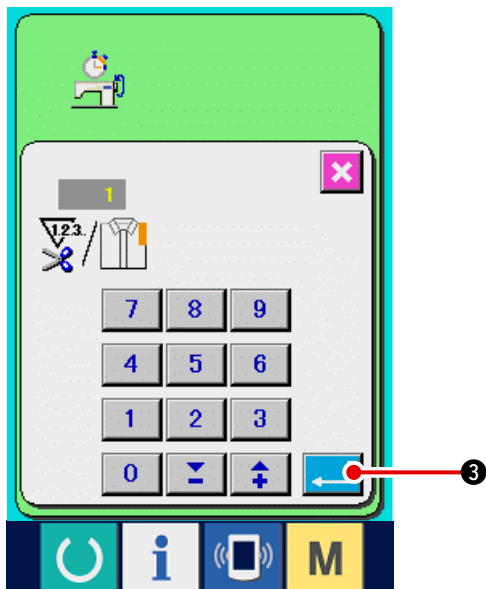

3) Input the number of times of thread trimming.

Next, input the number of times of thread trimming per process. When number of times of thread trimming button  5 in the previous page is pressed, the number of times of thread trimming input screen is displayed.

Input the value you desire with ten keys or UP/DOWN buttons.

After the input, press ENTER button  3.

 **When the input value is 0, count of the number of times of thread trimming is not performed. Use this function by connecting the external switch.**

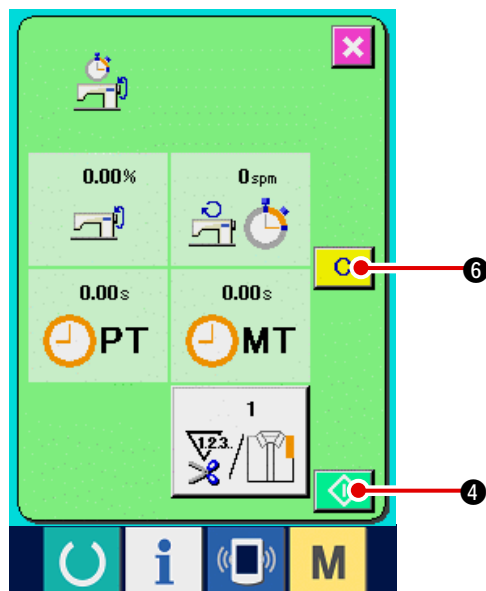



4) Start the measurement.

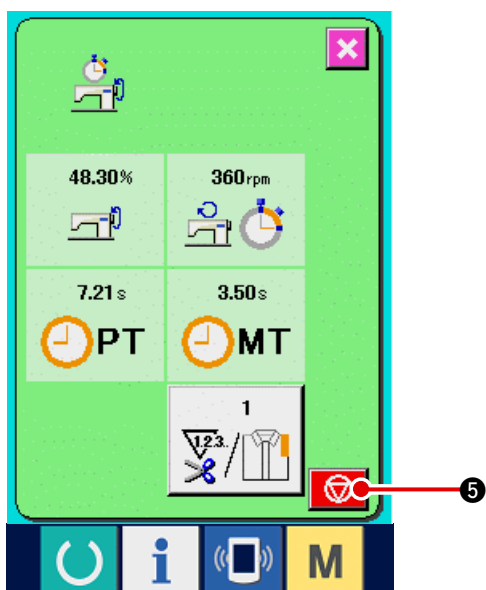

When START button  4 is pressed, measurement of each data is started.



5) Stop the count.

Display the working measurement screen referring to 1) and 2) of "[17-6 Observing the working measurement information](#)".

STOP switch  5 is displayed when the measurement is being performed. When STOP switch  5 is pressed, the measurement is stopped.

After the stop, START button  4 is displayed at the position of STOP button. To continue measuring, press START button  4 again. The measured value is not cleared until CLEAR button  6 is pressed.

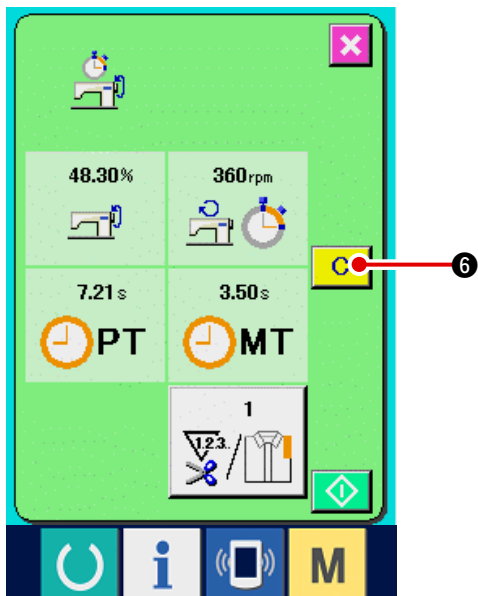

6) Clear the counted value.

When clearing the counted value, set the count to the stop state and press CLEAR button **C**

6.

(Note)

CLEAR button is displayed in case of the stop state only.

When CLEAR button **C** **6** is pressed, the clear confirmation screen is displayed.

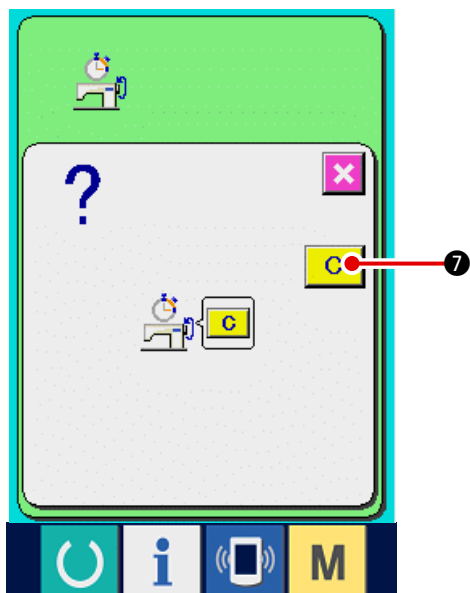

When CLEAR button **C** **7** is pressed in the clear confirmation screen, the counted value is cleared.

18. TRIAL SEWING FUNCTION

Data created with PM-1 (sewing data creation and edit software) can be sewn on trial by on-line connection of the personal computer with the sewing machine.

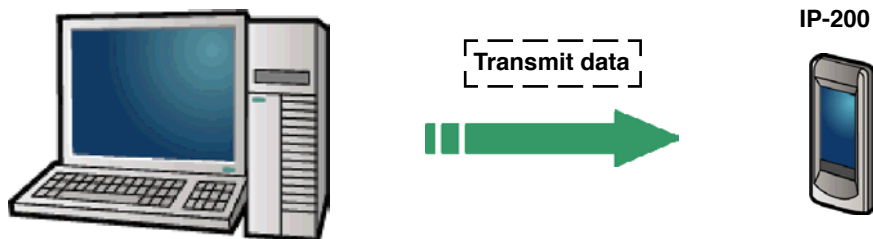

Connect the personal computer with IP-200 and transmit data to the sewing machine after creation of data with PM-1. When IP-200 becomes the data input screen, automatically the trial sewing screen is displayed. For the operating procedure of PM-1, see HELP of PM-1 or the like.

18-1 Performing trial sewing

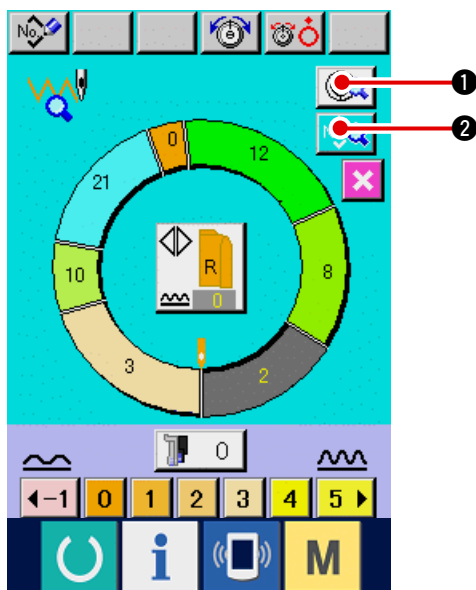



1) Receive the trial sewing data from PM-1.

When the trial sewing data (vector format data) is transmitted from PM-1, the screen on the left side is displayed, and the transmitted data is displayed in the center of the screen.

The display corresponds with the length between steps set with PM-1.

2) Edit the vector parameter.

Vector format data transmitted from PM-1 is converted to the parameter that can be set with the sewing machine. Thereby, it is possible to perform the same edit as the normal pattern.

- When STEP DETAILS button  ① is pressed, the step details setting screen is displayed.
- When SEWING DATA DISPLAY button  ② is pressed, the sewing data setting screen is displayed.

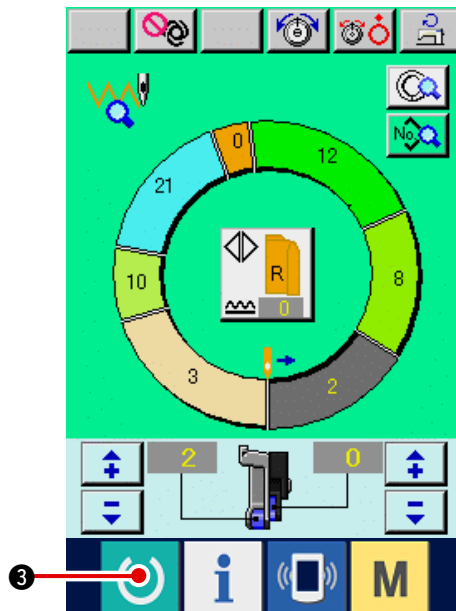

3) Perform trial sewing.

When READY switch  ③ is pressed, the trial sewing screen is displayed. Trial sewing can be performed in this state.

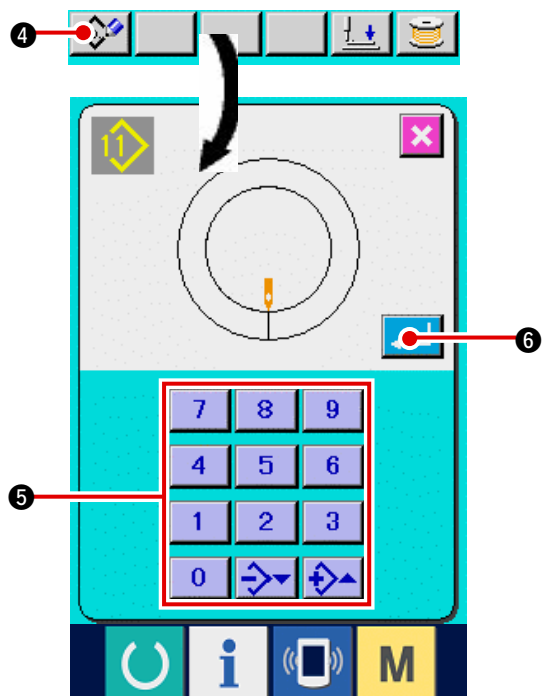

4) Register the data to the pattern.

When the data which has been sewn on trial is registered to the panel, press REGISTER button  ④ displayed in the trial sewing screen, and the register screen is displayed. Input the pattern No. you desire to register with ten keys



5) Determine the register of the data.

When ENTER button  ⑥ is pressed, the register screen is closed and the register has been completed.

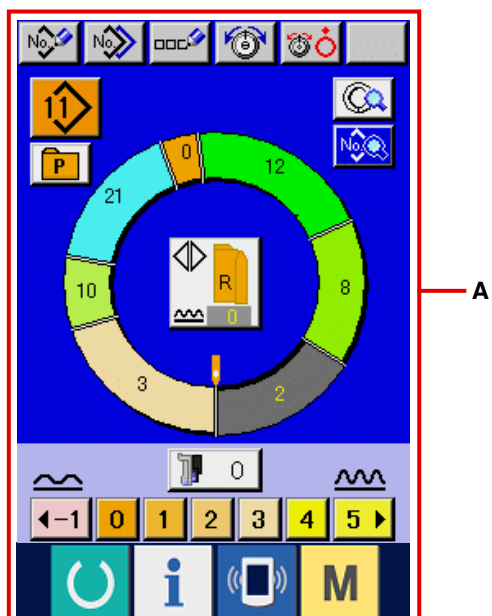

6) Display the data input screen.

After completion of the register, automatically the data input screen **A** is displayed.

19. PERFORMING KEY LOCK

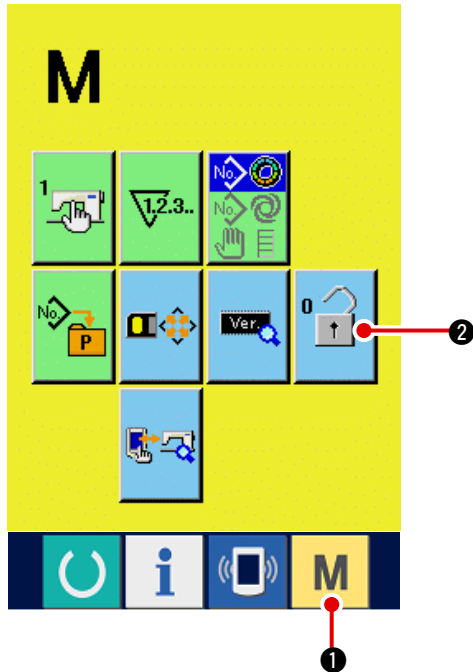

1) Display the key lock screen.

Press **M** ① key for three seconds, and the

KEY LOCK button  ② is displayed on the

screen. When this button is pressed down, the key lock screen is displayed.

The existing setting state is displayed on the KEY LOCK button.



: State that key lock is not set





: State that key lock 1 is set

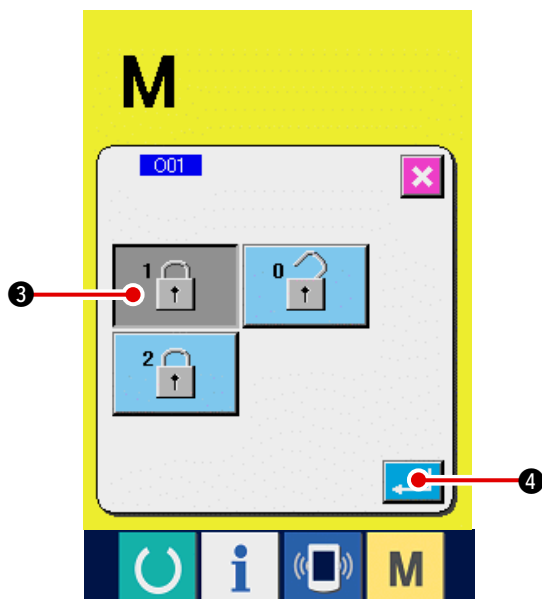

: State that key lock 2 is set



2) Select and determine the key lock state.

Select the key lock state button  ③ in the key lock setting screen, and press  ④.

Then the key lock setting screen is closed and the key lock state is set.

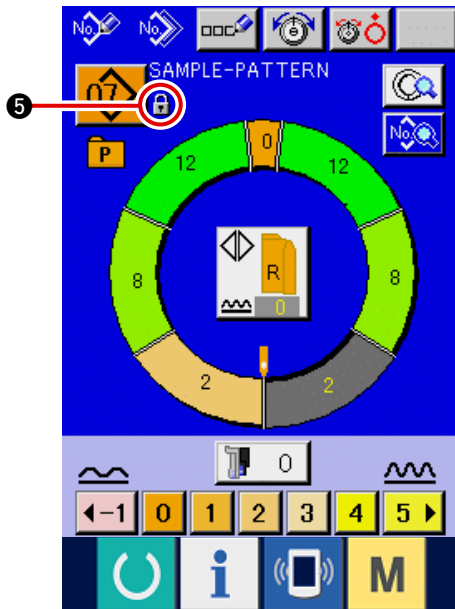

3) Close the mode screen and display the data input screen.

When the mode screen is closed and the data input screen is displayed, pictograph  5 showing the key lock state is displayed on the right-hand side of the pattern No. display. Besides, only the buttons which are possible to be used even in the key lock state are displayed.

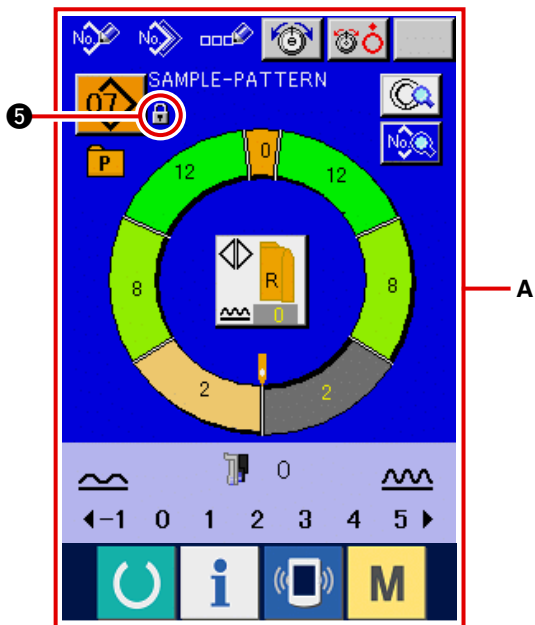

* State that key lock 2 is set **A**

20. DISPLAYING VERSION INFORMATION

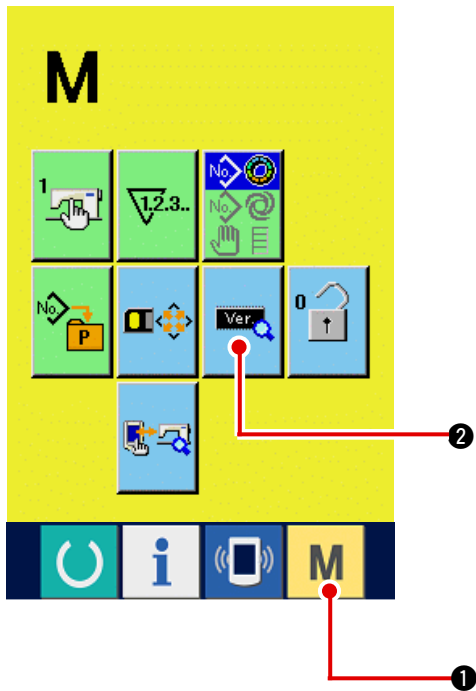

1) Display the version information screen.

Press **M** ① key for three seconds, and the

VERSION INFORMATION button  ② is

displayed on the screen. When this button is pressed down, the version information screen is displayed.

The version information on the sewing machine you use is displayed on the version information screen, and it is possible to check it.

① : Version information on panel program

② : Version information on main program

③ : Version information on servo program

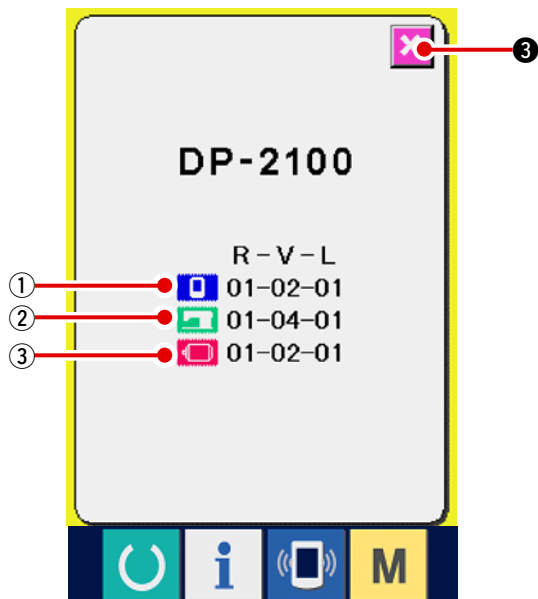



When CANCEL button  ③ is pressed, the

version information screen is closed and the mode screen is displayed.

21. USING CHECK PROGRAM

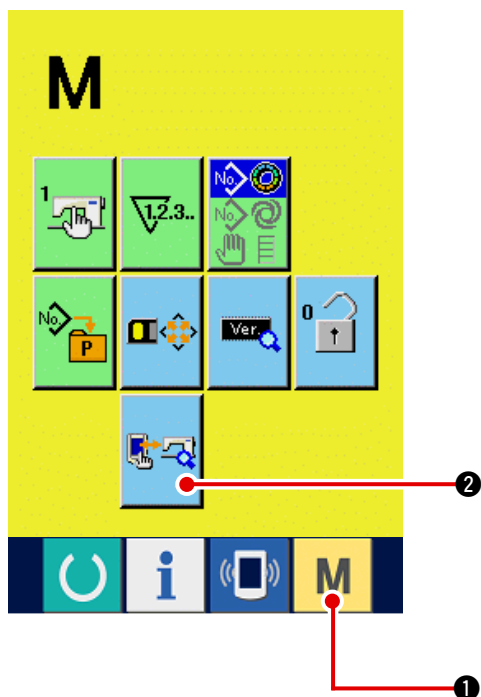
21-1 Displaying the check program screen



Press **M** ① key for three seconds, and CHECK PROGRAM button  ② is displayed on the screen. When this button is pressed down, the check program screen is displayed.

There are 5 items below in the check program.



I01 Auxiliary pedal setting

Refer to "[21-2 Performing the auxiliary pedal setting](#)".

I02 Checking of A/D value of auxiliary pedal

Refer to "[21-3 Performing checking of A/D value of auxiliary pedal](#)".

I03 LCD check

Refer to "[21-4 Performing LCD check](#)".

I04 Touch panel compensation

Refer to "[21-5 Performing touch panel compensation](#)".

I05 Input signal check

Refer to "[21-6 Performing the input signal](#)".

I06 Output signal check

Refer to "[21-7 Performing the output signal](#)".

21-2 Performing the auxiliary pedal setting

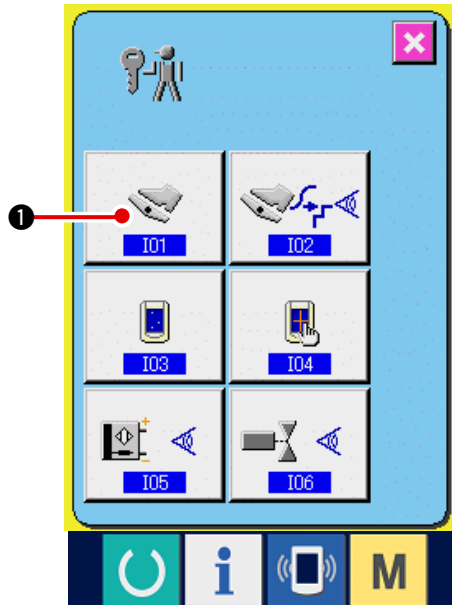





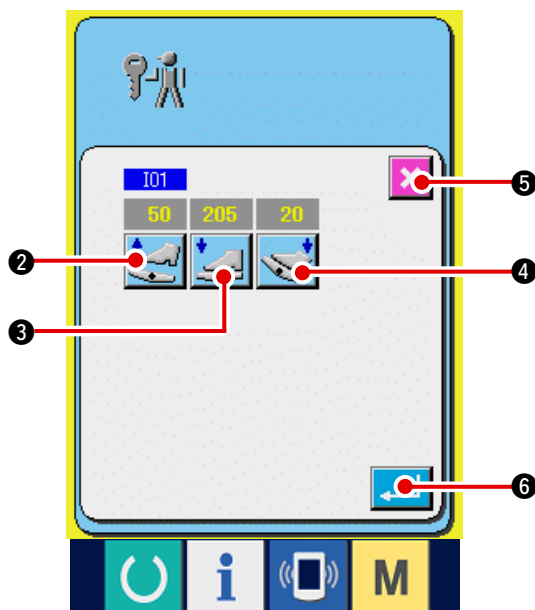

1) Display the auxiliary pedal setting screen.

When AUXILIARY PEDAL SETTING button  ① in the check program screen is pressed, the auxiliary pedal setting screen is displayed.



2) Perform the auxiliary pedal setting.

- Auxiliary pedal release position setting :
Release the auxiliary pedal and press AUXILIARY PEDAL RELEASE POSITION SETTING button  ②. When the display is determined, press  ⑥ to determine the data.
- Auxiliary pedal front-part depressing position setting :
Depress the front-part of auxiliary pedal and press AUXILIARY PEDAL FRONT-PART DEPRESSING POSITION SETTING button  ③. When the display is determined, press  ⑥ to determine the data.
- Auxiliary pedal back-part depressing position setting :
Depress the back-part of auxiliary pedal and press AUXILIARY PEDAL BACK-PART DEPRESSING POSITION SETTING button  ④. When the display is determined, press  ⑥ to determine the data.

• When all settings are completed, press CANCEL button  ⑤ to complete the setting. The screen returns to the check program screen.

* Error occurs when CANCEL button  ⑤ is pressed unless the difference of each setting item is 5 or more,

21-3 Performing checking of A/D value of auxiliary pedal

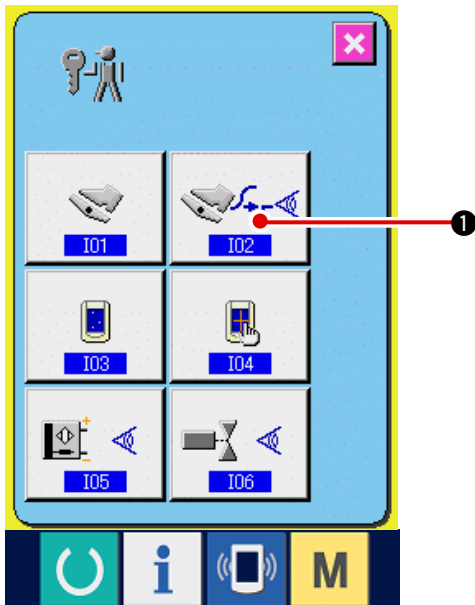

- 1) Display the check screen of A/D value of auxiliary pedal.

When CHECK button  ① of A/D value of auxiliary pedal of the check program screen is pressed, the A/D value of auxiliary pedal check screen is displayed.

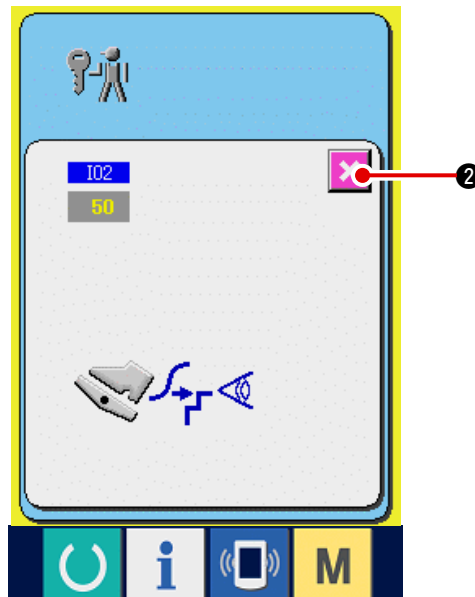

- 2) Perform checking of A/D value of auxiliary pedal.

When the auxiliary pedal is depressed, A/D value corresponding to the depressing amount is displayed.

After checking, press CANCEL button  ②.

The screen returns to the check program screen.

21-4 Performing LCD check

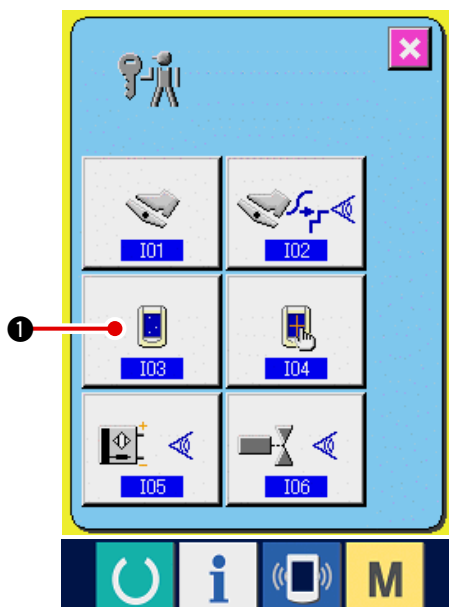

- 1) Display the LCD check screen.

When LCD CHECK button  ① on the check program screen is pressed, the LCD check screen is displayed.

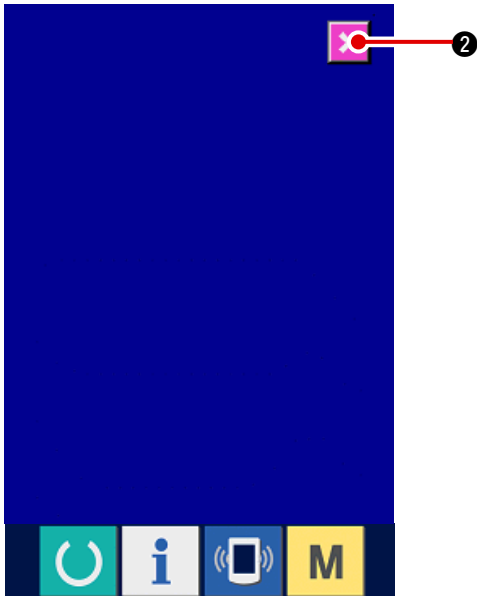

2) Check whether any dot of LCD is omitted.

The screen of LCD check screen is displayed by one color only. Check in this state whether any dot is omitted or not.

After checking, press CANCEL button  **2** .

The LCD check screen is closed and the check program screen is displayed.

21-5 Performing touch panel compensation

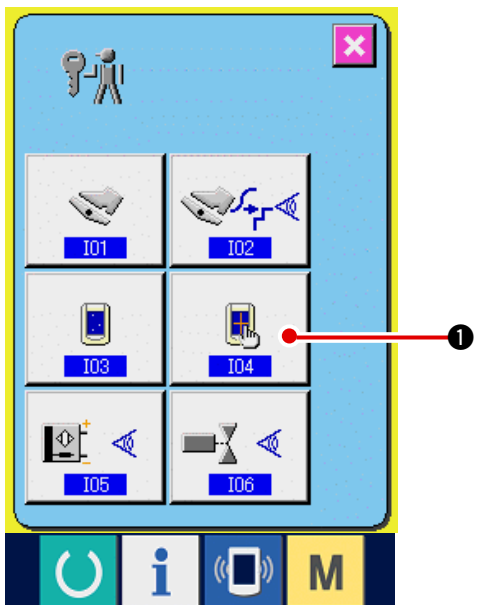

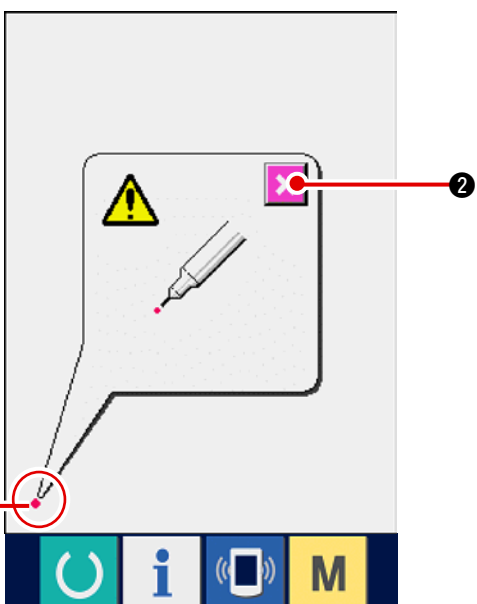

1) Display the touch panel compensation screen.

When TOUCH PANEL COMPENSATION button  **1** on the check program screen is pressed, the touch panel compensation screen is displayed.



2) Press the lower left position.

Press red circle  **3** located at the lower left position on the screen.

When finishing the compensation, press CANCEL button  **2** .

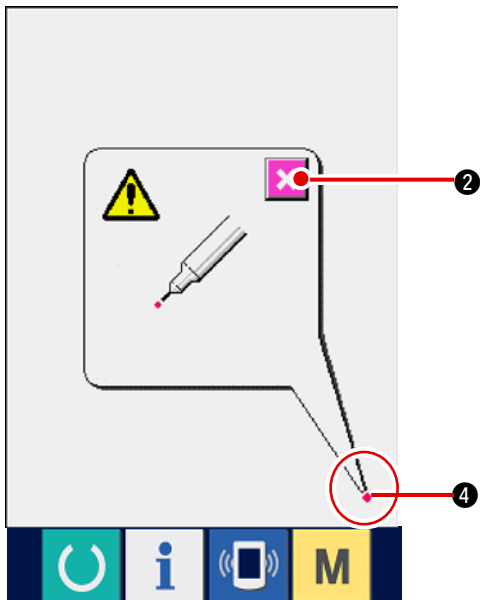

- 3) Press the lower right position.
 Press red circle ● 4 located at the lower right position on the screen.
 When finishing the compensation, press CANCEL button  2.

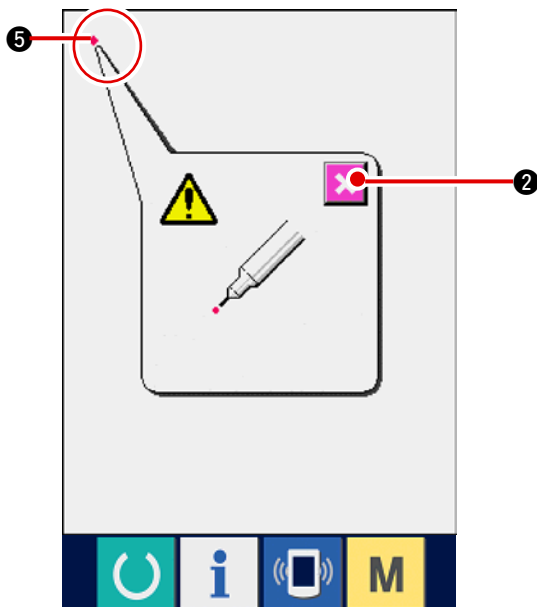

- 4) Press the upper left position.
 Press red circle ● 5 located at the upper left position on the screen.
 When finishing the compensation, press CANCEL button  2.

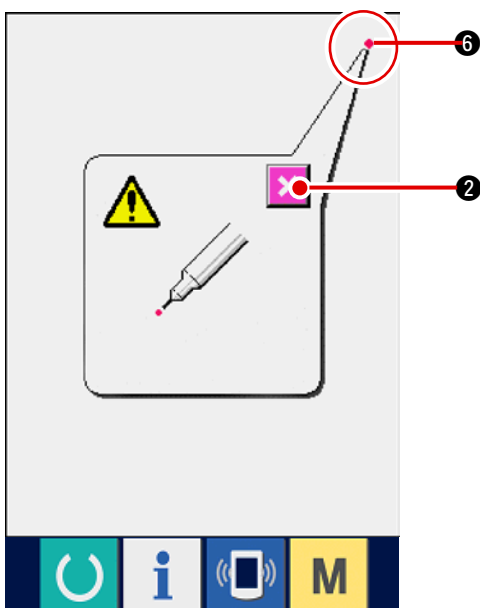

- 5) Press the upper right position.
 Press red circle ● 6 located at the upper right position on the screen.
 When finishing the compensation, press CANCEL button  2.

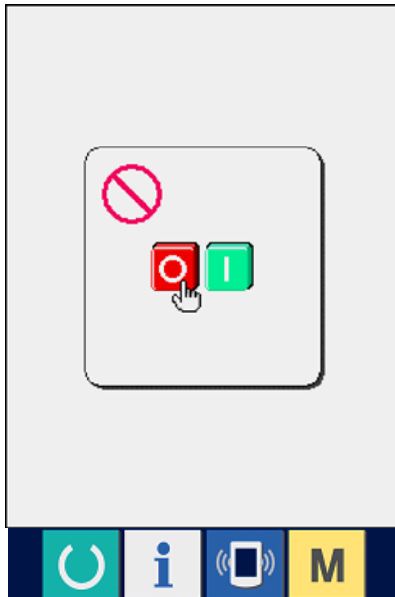

6) Store the data.

When 4 points have been pressed, the screen showing power-OFF prohibition is displayed since the compensation data are to be stored.

Do not turn OFF the power while this screen is being displayed.

When the power is turned OFF, the compensated data are not stored.

When storing is finished, the check program screen is automatically displayed.

21-6 Performing the input signal check

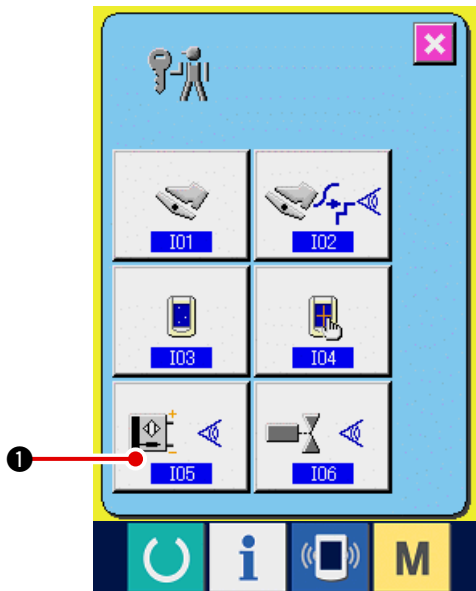

1) Display the input signal check screen.

When INPUT SIGNAL CHECK button  ① of the check program screen is pressed, the input signal check screen is displayed.

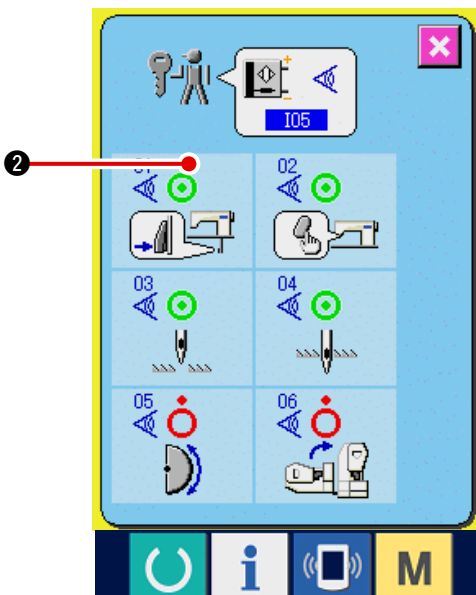

2) Perform the input signal check.

Input state of the input signal can be checked in the input signal check screen.

Input state is displayed as ② with every input signal.

Display of ON/OFF state is shown as below :















: ON state



: OFF state

6 kinds of the input signals are displayed as below.

No.	Pictograph	Description of sensor
		Step changeover switch
		Shirring release switch
		Needle UP position detection
		Needle DOWN position detection
		Head tilt sensor
		Semilunar plate detection

21-7 Performing the output signal check

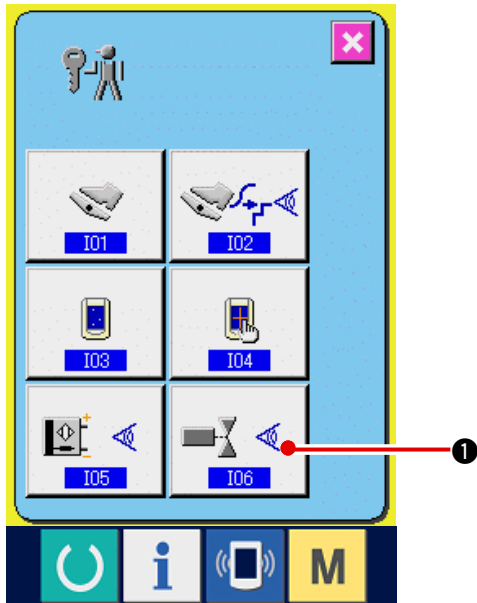

1) Display the output signal check screen.

When OUTPUT SIGNAL CHECK button  of the check program screen is pressed, the

output signal check screen is displayed.

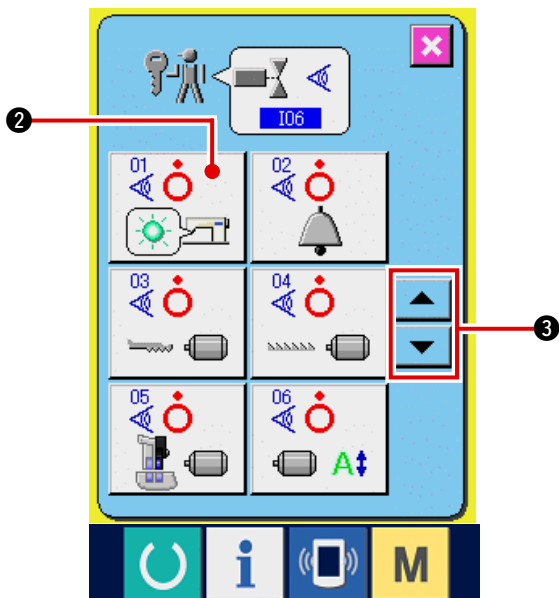

2) Perform the output signal check.

Output state of the various output signals can be checked in the output signal check screen.

Output state is displayed as ② with every output signal.



Display of ON/OFF state is shown as below.



















: ON state

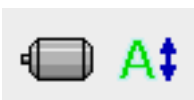

: OFF state

Press UP/DOWN buttons   ③ to check the output signal you desire to check.

9 kinds of the output signals are displayed as below.





No.	Pictograph	Description of sensor
		Shirring release LED
		Buzzer
		Top feed stepping motor
		Bottom feed stepping motor
		Auxiliary feed stepping motor
		Stepping motor current
		Stepping motor OFF
		Presser lifter solenoid
		Thread trimmer solenoid

22. COMMUNICATION SCREEN OF MAINTENANCE PERSONNEL LEVEL

For the communication screen, the level which is normally used and the one which is used by the maintenance personnel are different in the kinds of data to be handled.

22-1 Data which are possible to be handled in case of the maintenance

personnel level, it is possible to use 5 different kinds of data in addition to the normal two kinds. The respective data formats are as below.

Data name	Pictograph	Extension	Description of data
Adjustment data		Model name+00△△△.msw Example) DP00001.msw	Data of memory switches 1 and 2
All sewing machine data		Model name+00△△△.msp Example) DP00001.msp	All data which are held by sewing machine
Panel program data (*)		IP+RVL(6 digits).prg IM+RVL(6 digits).bhd	Program data and display data of panel
Main program data (*)		MA+RVL(6 digits).prg	Program data of main
Servo program data (*)		MT+RVL(6 digits).prg	Program data of servo



△△△ : File No.

- * For panel program data, main program data and servo program data, refer to the Set-up Manual for IP-200.

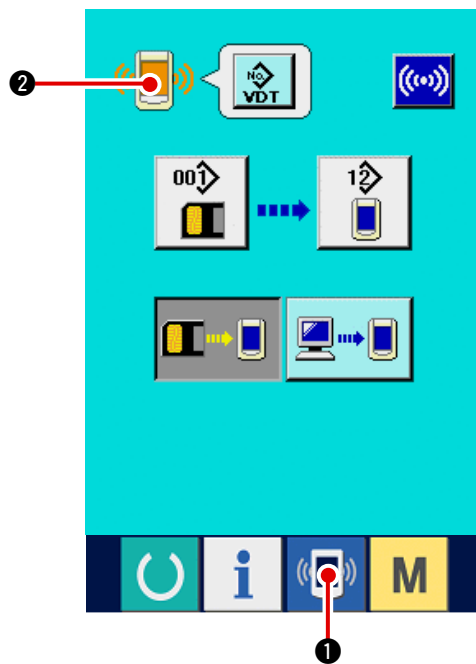
22-2 Displaying maintenance personnel level



1) Display the communication screen of the maintenance personnel level.

When key  ① is pressed as long as three seconds, the image located at the upper left position is changed to orange color  ② and the communication screen of the maintenance personnel level is displayed.

For the operating procedure, refer to "[16-4 Take-in of the data](#)".

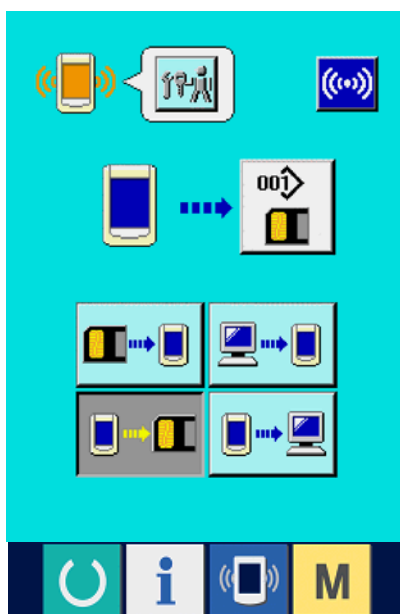

- * When the adjustment data or the all sewing machine data is selected, the display becomes as shown on the right-hand side and it is not necessary to specify No. on the panel side.

23. INFORMATION SCREEN OF THE MAINTENANCE PERSONNEL LEVEL

23-1 Display of error record

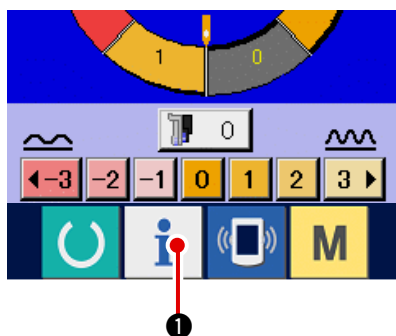

1) Display the information screen of the maintenance personnel level.

When INFORMATION key  ① of switch seat section is pressed for approximately three seconds in the data input screen, the information screen of the maintenance personnel level is displayed. In case of the maintenance personnel level, the pictograph located at the upper left position changes from blue color to orange color, and 5 buttons are displayed.

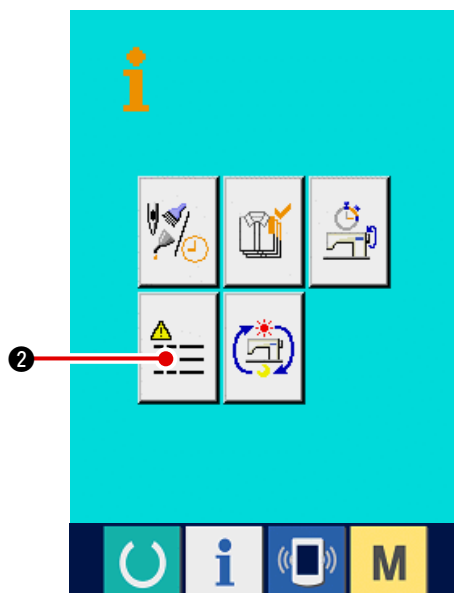

2) Display the error record screen.

Press ERROR RECORD SCREEN DISPLAY button  ② in the information screen. The error record screen is displayed.

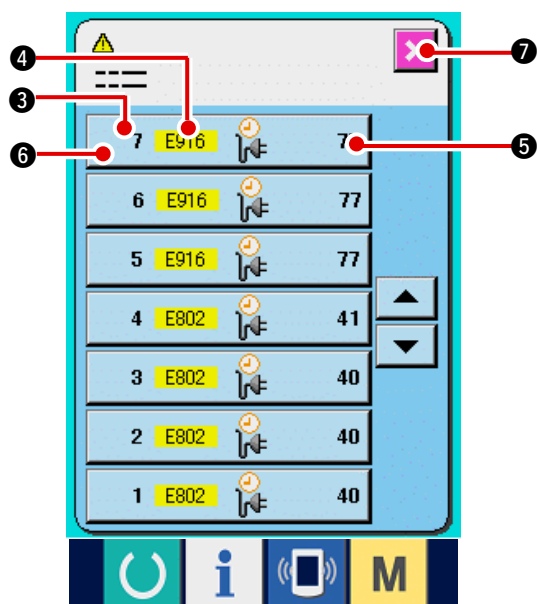

Error record of the sewing machine you use is displayed in the error record screen, and you can check the error.

- ③ : Order that error has occurred.
- ④ : Error code
- ⑤ : Cumulative current-carrying time (hour) at the time of occurrence of error

When CANCEL button  ⑦ is pressed, the error record screen is closed and the information screen is displayed.

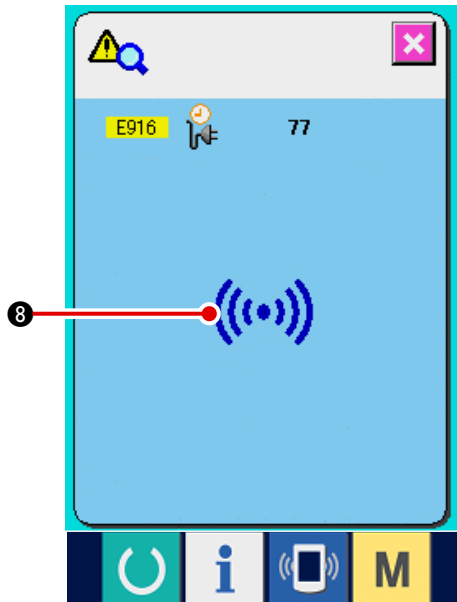

3) Display the details of error.

When you desire to know the details of error, press ERROR button  6 you desire to know. The error detail screen is displayed.

Pictograph 8 corresponding to the error code is displayed in the error detail screen.

Refer to "[15. ERROR CODE LIST](#)".

23-2 Display of the cumulative working information

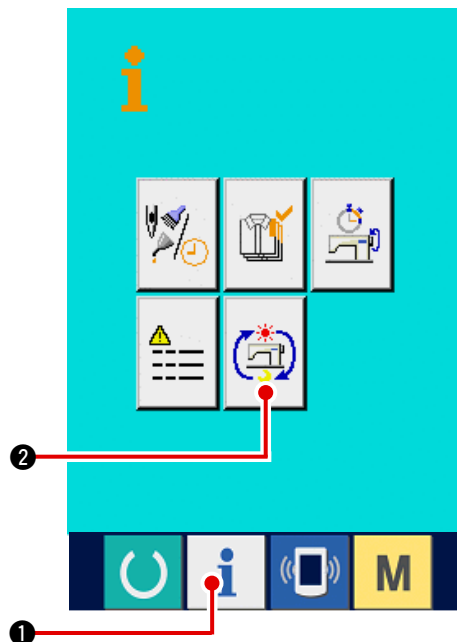

1) Display the information screen of the maintenance personnel level.

When INFORMATION key  1 of switch seat section is pressed for approximately three seconds in the data input screen, the information screen of the maintenance personnel level is displayed. In case of the maintenance personnel level, the pictograph located at the upper left position changes from blue color to orange color, and 5 buttons are displayed.

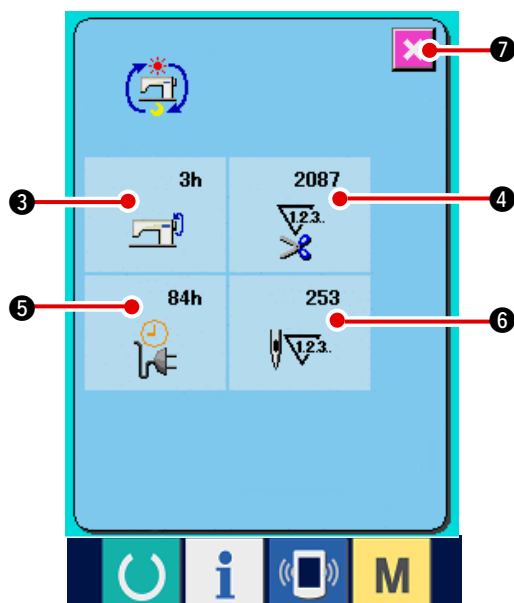

2) Display the cumulative working information screen.

Press CUMULATIVE WORKING INFORMATION

SCREEN DISPLAY button  2 of the

information screen. The cumulative working information screen is displayed.

Information on the following 4 items are displayed in the cumulative working information screen.

- 3 : Cumulative working time (hour) of the sewing machine is displayed.
- 4 : Number of cumulative times of thread trimming is displayed.
- 5 : Cumulative current-carrying time (hour) of the sewing machine is displayed.
- 6 : Number of cumulative stitches is displayed.(Unit : X1,000 stitches)

When CANCEL button  7 is pressed, the cumulative working information screen is closed and the information screen is displayed.

24. MAINTENANCE

24-1 Replacing procedure of feed belt



WARNING :

Turn OFF the power before starting the work so as to prevent accidents caused by abrupt start of the sewing machine.

Caution : The standard of the time of replacement is one year although it depends on the frequency of use. Replace the belt with a new one when it is observed that feed force is excessively deteriorated or the like.

Caution : Perform periodical cleaning approximately once a week since dust is collected inside the top feed cover and the belt rolls the dust resulting in feed trouble or short life of the belt.

(1) Replacing the top feed belt

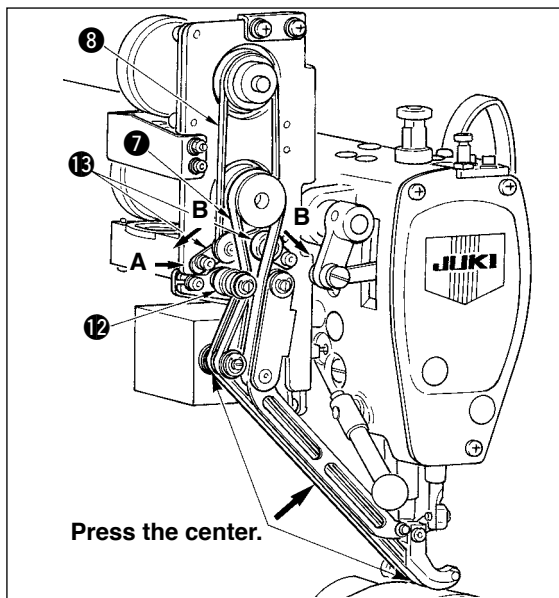
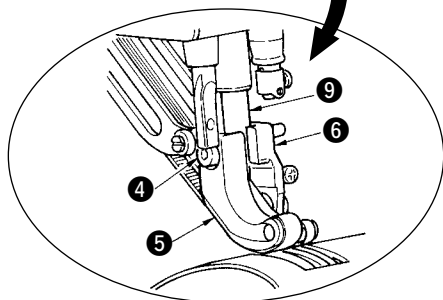
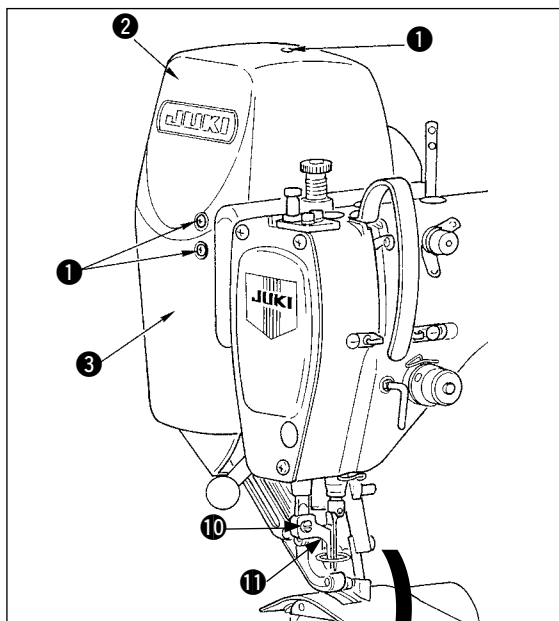

- 1) Remove ten cover setscrews ① and remove cover R ② and cover F ③.
- 2) Loosen intermediate presser foot screw ⑩ and remove intermediate presser foot ⑪.
- 3) Loosen walking foot setscrew ④ and remove walking foot ⑤ and auxiliary walking foot ⑥.
- 4) Remove main feed belt ⑦ and auxiliary feed belt ⑧, and replace them with new ones.
- 5) Put walking foot rod ⑨ between ⑤ and ⑥, and fix with screw ④.
- 6) After adjusting the belt tension, attach cover R ② and cover F ③.

■ Belt tension adjusting procedure

(1) Main feed belt :

Move tension adjustment plate L ⑫ to the left or right to adjust the belt.

- The tension is increased in the right-hand direction (direction A) and decreased in the left direction.

(2) Auxiliary feed belt :

Move tension adjustment plate S ⑬ to the left or right to adjust the belt.

- When it is opened on both sides (direction B), the tension is increased, and when it is closed, the tension is decreased.

(3) Adjusting the belt tension value :

1) Main feed belt :

The belt has to be bent by 3 mm when it is pressed with a load of 1.3N (130gf).

2) Auxiliary feed belt :

The belt has to be bent by 3 mm when it is pressed with a load of 0.4N (40gf).



Feed pitch error will be caused unless the tension is proper.

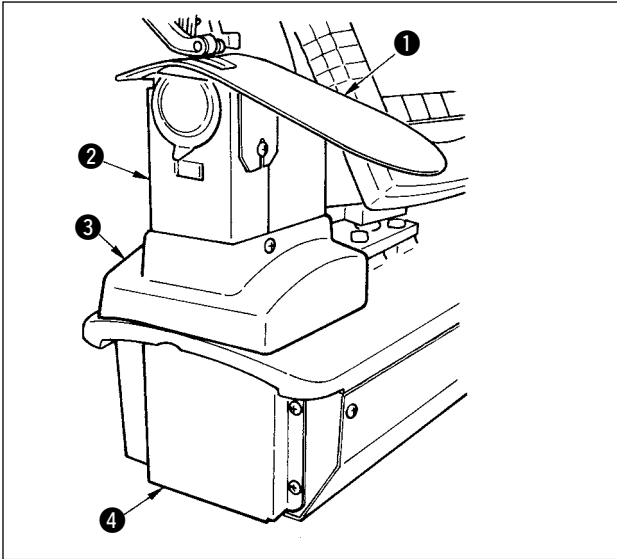

(2) Replacing the bottom feed belt

- 1) Turn presser lever ⑤, raise walking foot ⑥, and remove throat plate auxiliary plate ①, hook cover asm. ②, frame cover ③ and bottom feed cover ④.
- 2) Loosen setscrews ⑧ in the bottom feed tension plate.
- 3) Replace bottom feed belt ⑦ with a new one.

■ Adjusting procedure of the belt tension

Adjust bottom feed tension plate ⑨ to the left or right to adjust the tension.

(Tension is increased in direction A.)

Belt tension value :

The belt has to be bent by 3 mm when it is pressed with a load of 1.5N (150gf).



Feed pith error will be caused unless the tension is proper.

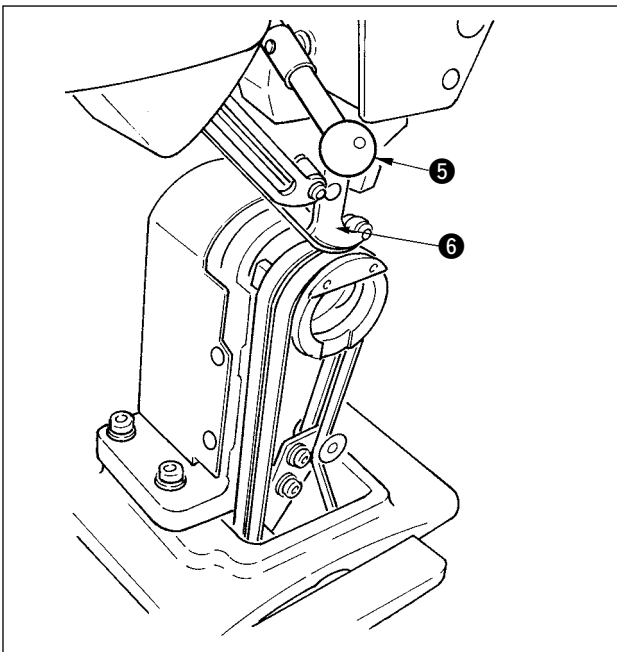

- 4) After adjustment of the tension, attach throat plate auxiliary plate ① and the various covers.

(3) Replacing the bottom feed roller

- 1) Turn presser lever ⑤, raise feed foot ⑥, and remove throat plate auxiliary plate ①, hook cover asm. ②, frame cover ③ and bottom feed cover ④.
- 2) Loosen inner hook presser setscrews ⑪ and remove inner hook presser ⑫.
- 3) Remove bottom feed roller ⑩ and replace it with a new one. Slightly apply the exclusive grease supplied as accessories (Part No. : 40006323) inside the roller.
- 4) Make sure of the bottom feed belt tension.
- 5) After adjusting the tension, attach throat plate auxiliary plate ① and various covers.

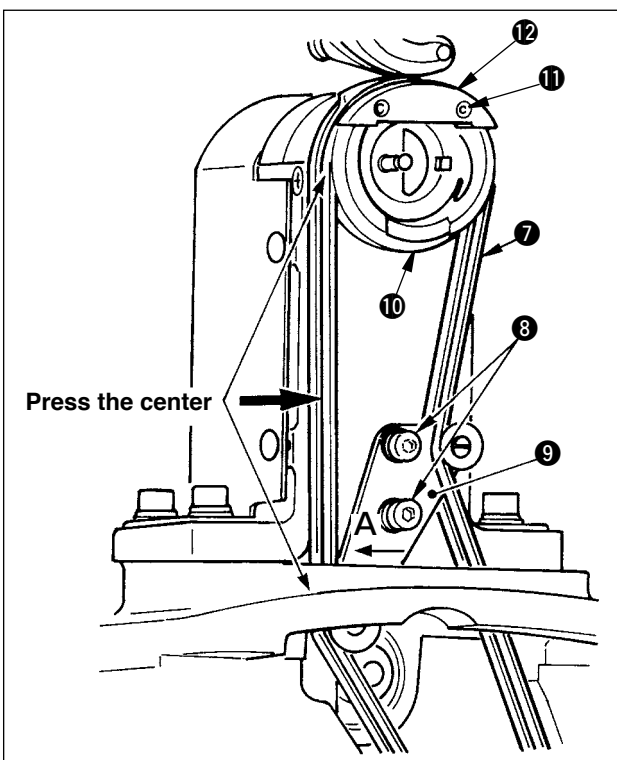

24-2 Changing the amount of alternate vertical movement of walking foot and presser foot



WARNING :

Turn OFF the power before starting the work so as to prevent accidents caused by abrupt start of the sewing machine.

(1) State of walking foot and presser foot at the time of delivery

Cam rod position	Top feed arm lowest position
Amount of alternate vertical movement of walking foot	0.2 to 0.3 mm
Clearance at lower dead point of walking foot	0.1mm
Amount of alternate vertical movement of presser foot	Approximately 2.7 mm
Clearance at lower dead point of presser foot	0.1mm

(2) Relation between amount of alternate vertical movement and max. sewing speed

	1	2	3	4
Amount of vertical movement of walking foot (mm)	Less than 0.3	Up to 1.5	Up to 2.5	Up to 3.5
Amount of vertical movement of presser foot (mm)	2.7	1.5	2.5	3.5
Max. sewing speed (rpm)	3500	2600	2000	1600



When changing the amount of alternate vertical movement, change max. sewing speed. When it is not changed, components breakage or damage occurs and the life of the machine is excessively shortened.

**WARNING :**

Turn OFF the power before starting the work so as to prevent accidents caused by abrupt start of the sewing machine.

(1) When making equal the amount of alternate vertical movement of walking foot and presser foot (When making the amount equal to 1.5 mm)

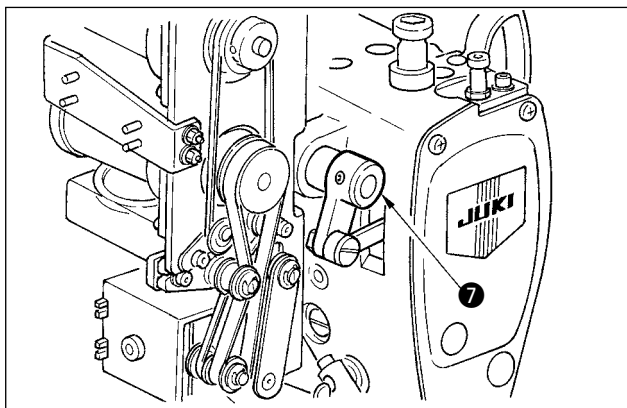
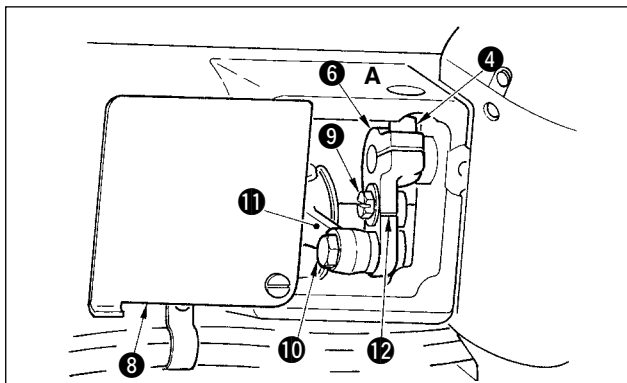
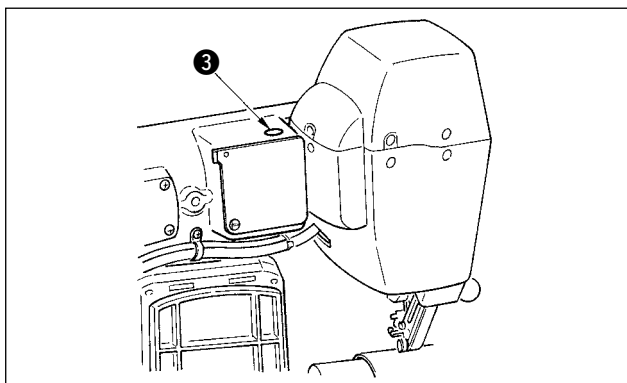

- 1) Bring the needle bar to its lower dead point.
- 2) Turn presser lever ①, raise walking foot ②, and insert "thickness gauge" of 1.6 to 1.7 mm or the like between the top feed belt and the bottom feed belt.



In case of 1.5 mm, thickness of 1.6 to 1.7 mm is settled since the compressed amount of belt slightly varies due to the presser pressure.

- 3) Remove stopper plug ③.
- 4) Insert a hexagonal wrench key from hole A, and loosen top feed arm clamp screw ④.
- 5) Tighten clamp screw ④ after checking that presser foot ⑤ has come down.



1. Remove the thrust of top feed arm ⑥ and drive shaft arm ⑦.
2. Set the tightening torque to 5.8N·m (60Kgf·cm).

- 6) Turn presser lever ① and remove the thickness gauge which has been inserted in step 2).

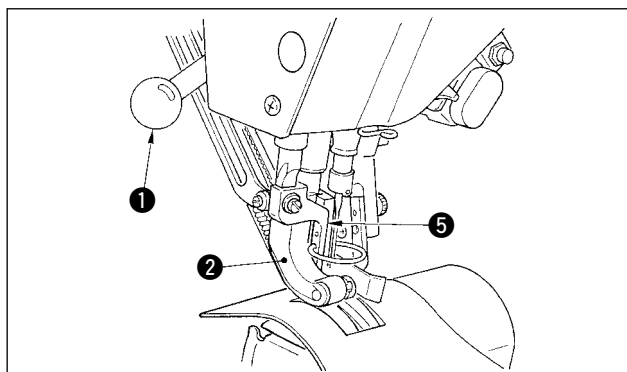

(2) When making 2.5 mm the amount of alternate vertical movement

(When the amount is already made equal to 1.5 mm, perform from item 1) below. When the amount is not made equal to 1.5 mm, Perform first "(1) When making equal the amount of alternate vertical movement" of the aforementioned item.

- 1) Turn top feed arm cover ⑧.
- 2) Loosen stopper screw ⑨ and remove the stopper.
- 3) Loosen top feed hinge screw ⑩.
- 4) Turn cam rod ⑪, adjust the position to the engraved marker line on top feed arm ⑫, and tighten hinge screw ⑩.



When turning the cam rod and bringing the top feed arm to its top end, the amount of alternate vertical movement becomes 3.5 mm.

24-3 Adjusting the height of the walking foot and the presser foot



WARNING :

Turn OFF the power before starting the work so as to prevent accidents caused by abrupt start of the sewing machine.

(1) Adjusting the height of walking foot

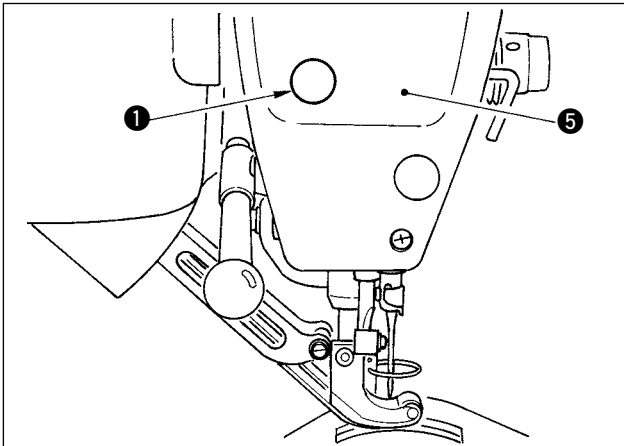

- 1) Bring the needle bar to its upper dead point.
- 2) Remove stopper plug ①.
- 3) Insert a hexagonal wrench key into the hole from which the stopper plug has been removed, and loosen walking foot bar bracket clamp screw ②.
- 4) Move walking foot ③ up or down in the range of 0.1 to 1.0 mm and tighten screw ②.

1. Clearance between top and bottom feed belts (dimension A) is 0.1 to 1.0 mm. If the clearance is more than the specified dimension, components come in contact with each other.



2. When tightening screw ②, be careful of the parallel of walking foot ③ and presser foot ④. Bend of material or feed trouble will be caused.

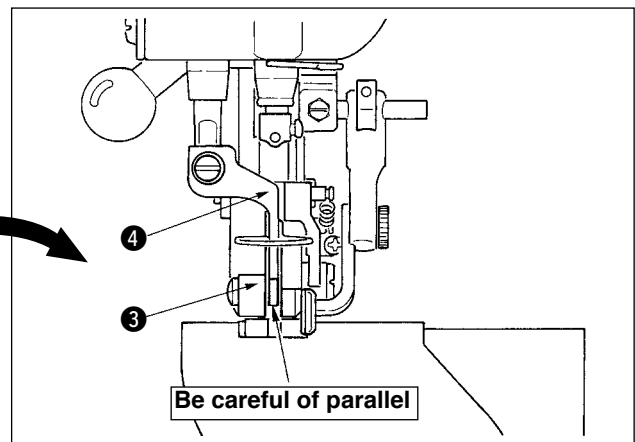
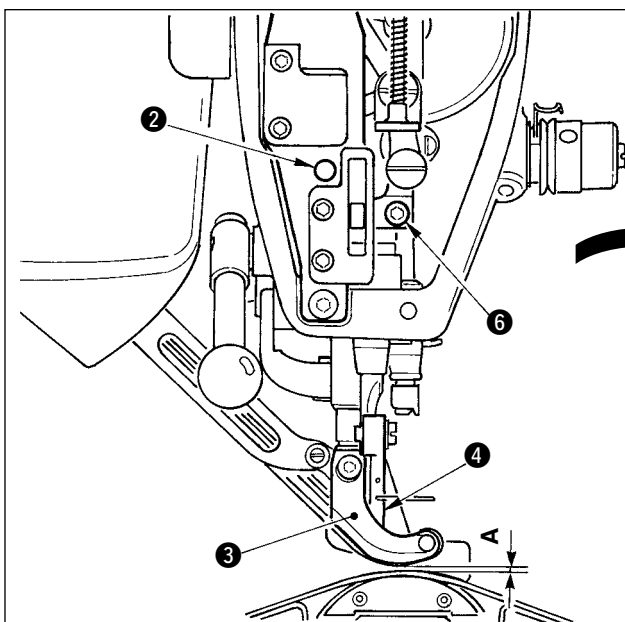

When the clearance becomes larger than the specified value, feed force is deteriorated. So, be careful.

(2) Adjusting the height of presser foot

- 1) Bring the needle bar to its lower dead point.
- 2) Remove face plate ⑤.
- 3) Loosen presser foot bar bracket clamp screw ⑥.
- 4) Move upward presser foot ④ in the range of 0.1 to 0.5 mm and tighten screw ⑥.



1. Clearance between the bottom surface of presser foot and the needle hole guide has been factory-adjusted to 0.1 mm at the time of delivery.

2. When the clearance becomes larger than the specified value, feed force is deteriorated. So, be careful.

24-4 Adjusting the needle and the hook



WARNING :

Turn OFF the power before starting the work so as to prevent accidents caused by abrupt start of the sewing machine.

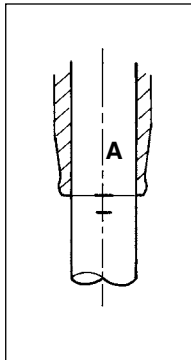
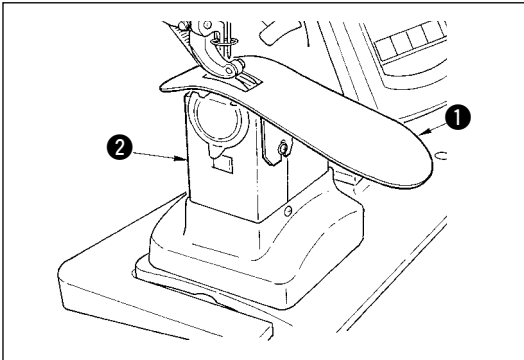

(1) Adjusting the height of needle bar

- 1) Remove throat plate auxiliary plate **1** and hook cover asm. **2**.
- 2) Remove hook base **3**.
- 3) Bring needle bar **4** to its lower dead point, and loosen needle bar bracket clamp screw **5**.
- 4) Adjust needle bar engraved marker line **A** to bottom end **6** of needle bar lower bushing, and tighten clamp screw **5**.

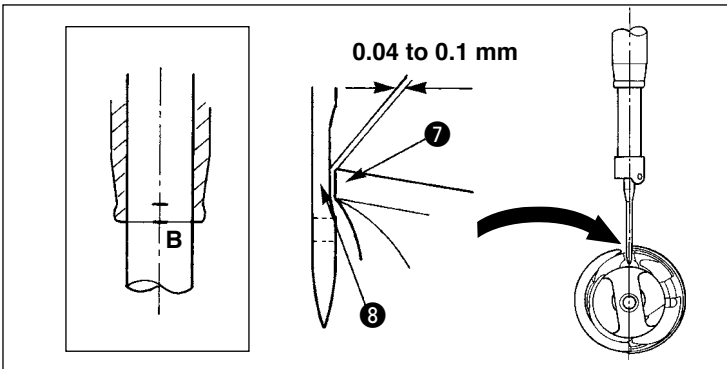

(2) Adjusting the hook

- 1) Loosen three setscrews in the hook, turn the handwheel, and adjust needle bar engraved marker line **B** to bottom end **6** of needle bar bushing.
- 2) Adjust blade point **7** of hook to the center of needle **8** so that the clearance between the blade point and the needle is 0.04 to 0.1mm (standard). Then tighten the setscrews in the hook.

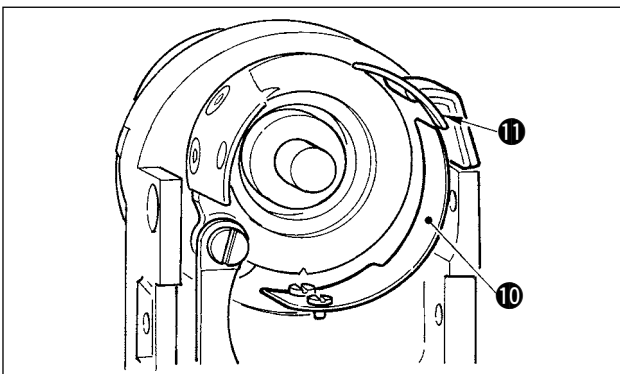

- 3) Put bottom feed belt **9** to hook base **3**, and assemble it to the hook shaft base. At this time, adjust the clearance between the bottom surface of the feed foot (bottom surface of top feed belt) and the top surface of the bottom feed belt to 0.1 mm at the upper dead point of the needle bar.

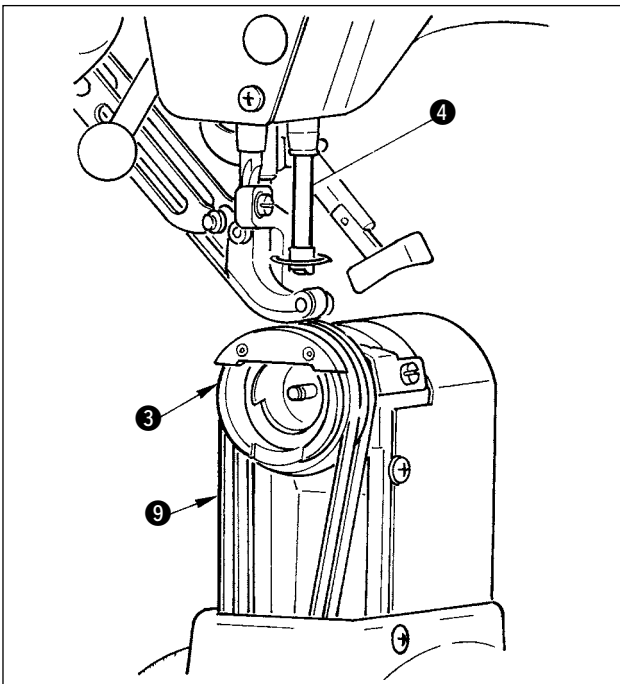

1. When the clearance is excessively smaller than the specified value, the blade point of hook is damaged, and the clearance is excessively larger, stitch skipping will be caused.
2. Fit counter knife guard **10** located inside the hook base to the inside of counter knife **11** since lift trouble will be caused.
3. RP hook (dry hook) rolls thread waste or cloth dust, and there is a possibility of breakdown or sewing trouble. Periodically perform cleaning of the hook.

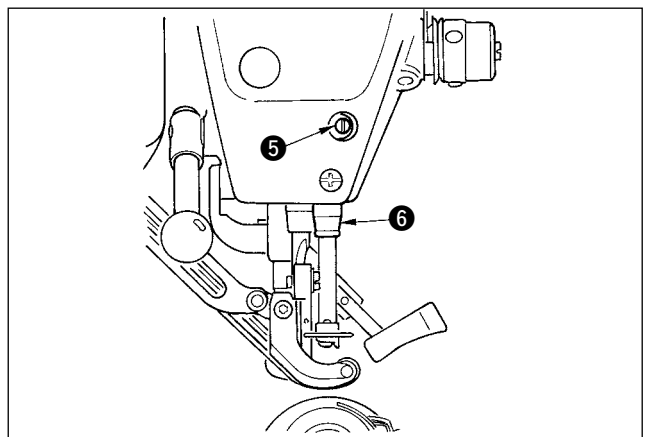

24-5 Adjusting the thread trimmer



WARNING :

Turn OFF the power before starting the work so as to prevent accidents caused by abrupt start of the sewing machine.

(1) Adjusting the thread trimmer cam timing

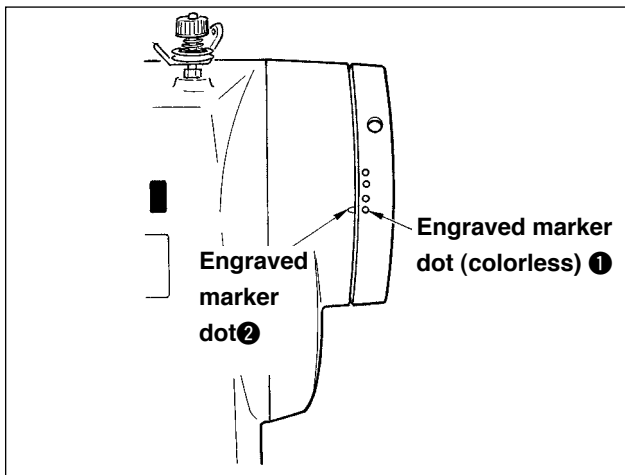

- 1) Turn the handwheel to the position where the thread take-up lever comes a little before its upper dead point.
- 2) Turn ON the thread trimmer solenoid and slide the roller to the thread trimmer cam to engage them with each other referring to "[21-7 Performing the output signal check](#)", and slide the roller to the thread trimmer cam to engage with each other.
- 3) In the state as it is, turn the handwheel in the normal operating direction and in the reverse direction. Then turn the handwheel until the handwheel stops.



When pulley cover engraved marker dot 2 aligns with engraved marker dot (colorless) 1 on the handwheel, the timing is normal.

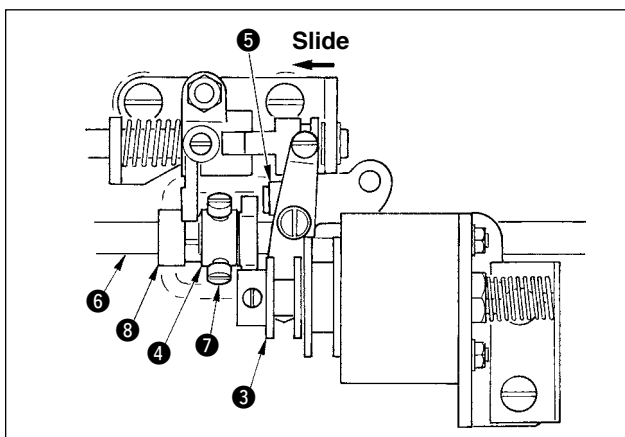

■ When the aforementioned normal timing is improper, adjust it with the procedure below.

- 1) Remove the bottom cover and loosen thread trimmer cam setscrews 7.
- 2) Adjust engraved marker dot (colorless) 1 on the handwheel to engraved marker dot 2 on the pulley cover.
- 3) Pressing drive block 3 to the right-hand, engage cam 4 with roller 5.
- 4) Turn cam 4 only in the reverse direction of the rotating direction of the hook driving shaft without turning hook driving shaft 6.
- 5) Press cam 4 to roller 5 at the position where cam 4 does not turn and tighten cam setscrews 7.

(2) Adjusting the initial position of the moving knife

The initial position of the moving knife is the position where engraved marker dot 1 on the hook shaft base aligns with V groove 2 on the moving knife base.

At this time, end 6 of the cam roller is higher by 1.7 mm than hook driving shaft center 7.

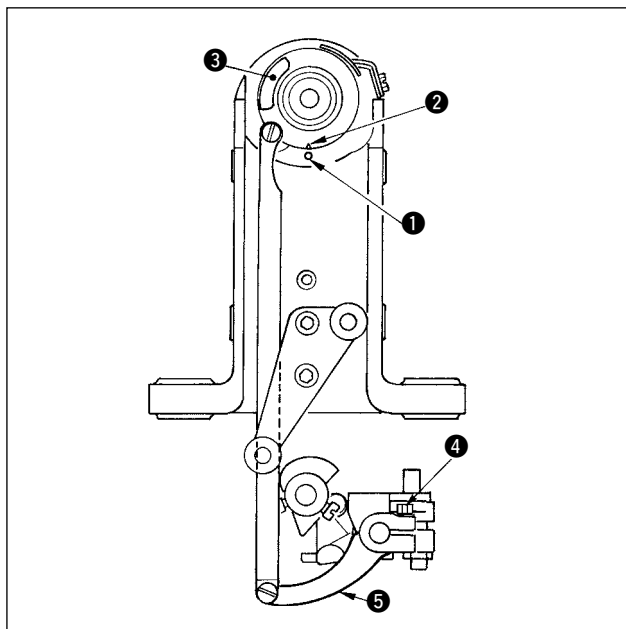

1) Adjusting the engraved marker dot

Loosen knife drive arm clamp screw 4, turn knife drive arm 5 so that engraved marker dot 1 aligns with V groove 2, and tighten the clamp screw.



When V groove 2 in terms of engraved marker dot 1 slips in the right-hand direction, the blade section of moving knife does not completely pass the blade section of counter knife. As a result, handling failure or thread trimming failure will be caused.

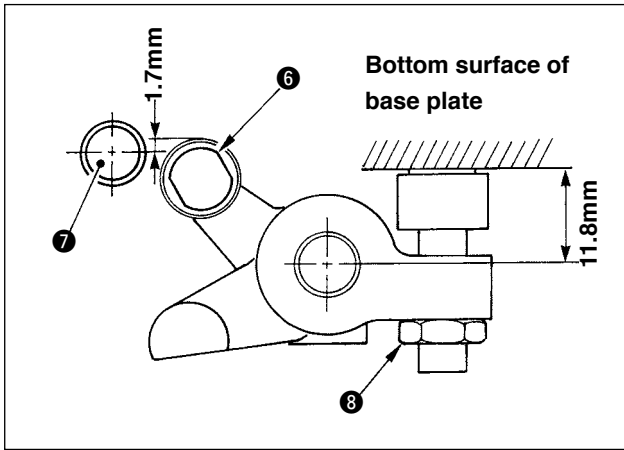

- 2) Adjusting the position of the cam roller
Loosen stopper lock nut ⑧, turn the stopper, and tighten cam roller ⑥ at the position of 11.8 mm.
(Refer to the illustration on the left side.)



1. When the position of cam roller ⑥ is excessively higher as against hook driving shaft ⑦, the moving knife rocking stroke is decreased and thread trimming failure will be caused.
2. On the contrary, the position is excessively lower, the rocking stroke is increased and the length of remaining needle thread is shortened or the blade point is damaged.

(3) Adjusting the initial position of the thread trimmer solenoid

Adjust the initial position so that the clearance between slide arm ① and drive shaft arm ② is 0.1 to 0.5 mm when the thread trimmer solenoid performs suction.

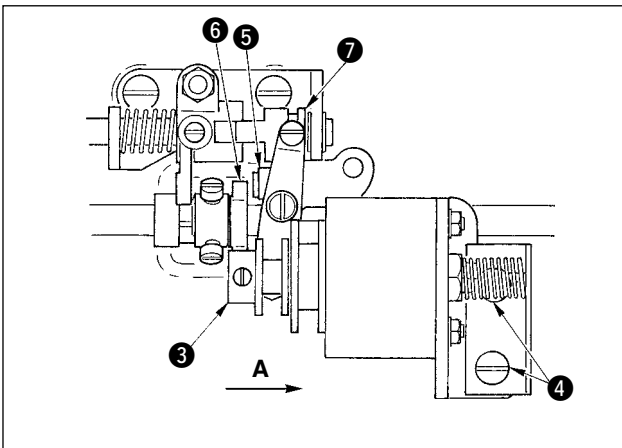

- 1) Remove the bottom cover, press drive block ③ by finger in the direction of arrow mark A. At this time, loosen setscrews ④ and adjust so that the clearance is 0.1 to 0.5 mm.
- 2) Take the finger off, and check that there is a clearance between cam roller ⑤ and edge ⑥ of the thread trimmer cam.
- 3) Secure an approximate clearance of 0.5 mm between slide arm ① and E ring ⑦.

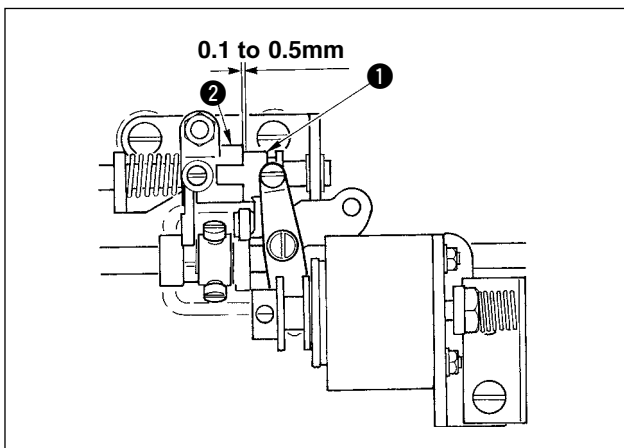

1. When the clearance is larger than the specified value, malfunction of thread trimming may occur.
2. When the clearance is smaller than the specified value, the load applied to each component is increased and there is a danger of occurrence of abnormal worn-out.

(4) Adjusting the position of the moving knife and the counter knife

Install moving knife ① by making it come in contact with the moving knife base.

Install counter knife ④ together with knife pressure adjustment plate ⑤.

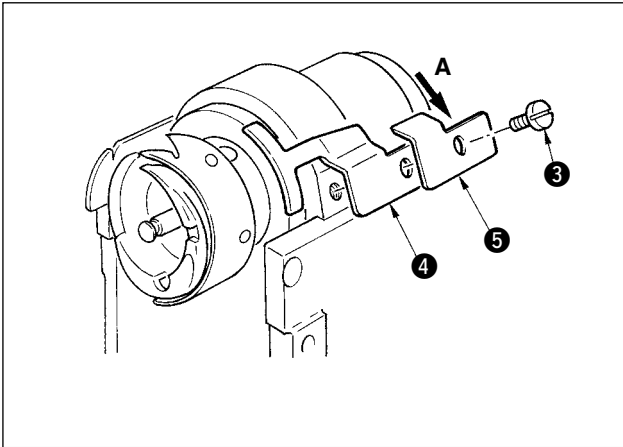
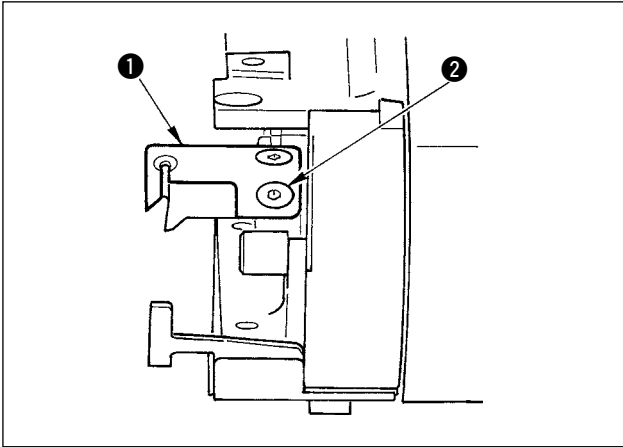

- 1) Loosen counter knife setscrew ③, adjust so that moving knife eyeend blade section ① and counter knife blade section ④ come in contact with each other in parallel, slightly press knife pressure adjustment plate ⑤ in the direction A, and tighten with the setscrew.

- Caution**
1. When they are not in parallel, remaining of thread end will be caused.
 2. When the knife pressure is low, thread trimming failure will be caused. When it is excessively high, it is related to the damage of the blade point of counter knife.

24-6 Greasing parts



WARNING :

Turn OFF the power before starting the work so as to prevent accidents caused by abrupt start of the sewing machine.

Periodically perform grease-up every 6 months as a standard .

For the grease, use the exclusive grease (Part No. : 40006323) supplied as accessories.

In addition, for the places to be greased, refer to the Engineer's Manual for DP-2100.

25. OTHERS

25-1 Troubles in sewing and the corrective measures

Troubles	Causes	Corrective measures
1. Thread breakage	<ol style="list-style-type: none"> ① Thread path, needle point, hook blade point or bobbin case resting on the throat plate has sharp edges or burrs. ② Needle thread tension is too high or too low. ③ Needle comes in contact with the blade point of hook. ④ Thread take-up spring works excessively or the stroke of the spring is too small. ⑤ Timing between the needle and the hook is excessively advanced. ⑥ Bobbin idling amount is too large. 	<ul style="list-style-type: none"> ○ Remove the sharp edges or burrs on the blade point of hook using a fine emery paper. Buff up the bobbin case resting groove on the throat plate. ○ Adjust the needle thread tension. ○ Refer to "Adjusting the needle and the hook". ○ Decrease the tension of the thread take-up spring and increase the stroke of the spring. ○ Refer to "Adjusting the needle and the hook". ○ Increase the spring pressure.
2. Stitch skipping	<ol style="list-style-type: none"> ① The clearance provide between the needle and the blade point of hook is too large. ② Timing between the needle and the hook is excessively advanced or retarded. ③ Pressure of the presser foot is too low. ④ Height of the walking foot or presser foot is too high. 	<ul style="list-style-type: none"> ○ Refer to "Adjusting the needle and the hook". ○ Refer to "Adjusting the needle and the hook". ○ Tighten the presser spring regulator. ○ Refer to "Adjusting the height of the walking foot and the presser foot".
3. Loose stitches	<ol style="list-style-type: none"> ① Bobbin thread is not put in the fork end of the thread tension spring of the bobbin case. ② Thread path has been poorly finished. ③ Bobbin fails to move smoothly. ④ Bobbin thread tension is too low. ⑤ Bobbin has been improperly wound. 	<ul style="list-style-type: none"> ○ Thread the bobbin case properly. ○ Grind the thread path using a fine emery paper. Buff up the thread path. ○ Replace the bobbin. ○ Adjust the bobbin thread tension. ○ Refer to "Winding a bobbin".
4. Thread slips off the needle eyelet simultaneously with thread trimming.	<ol style="list-style-type: none"> ① Returning force of the thread take-up spring is too strong. ② Thread tension given by the thread tension controller No. 1 is too high. ③ Position of the counter knife is improper. 	<ul style="list-style-type: none"> ○ Refer to "Threading the machine head". ○ Refer to "Threading the machine head". ○ Refer to "Adjusting the thread trimmer".
5. Needle thread is not rimmed. Bobbin thread is trimmed.	<ol style="list-style-type: none"> ① Stitch skipping at the last stitch (Clearance provided between the needle and the hook is excessive.) 	<ul style="list-style-type: none"> ○ Refer to "Adjusting the needle and the hook".
6. Both needle thread and bobbin thread are not trimmed.	<ol style="list-style-type: none"> ① Thread trimming timing is improper. ② Breakage of the knife ③ Pressure of the knife is insufficient. ④ Moving amount of the moving knife is insufficient. 	<ul style="list-style-type: none"> ○ Adjust the thread trimming timing. ○ Replace the knife. ○ Adjust the pressure of the knife. ○ Adjust the initial position of the moving knife.
7. Thread is not cut sharply.	<ol style="list-style-type: none"> ① Thread trimming timing is improper. ② Pressure of the knife is insufficient. ③ The knife has a blunt blade. 	<ul style="list-style-type: none"> ○ Adjust the thread trimming timing. ○ Adjust the pressure of the knife. ○ Replace the knife.
8. Material bends.	<ol style="list-style-type: none"> ① Top feed belt is bent. ② Height of the main walking foot and the auxiliary walking foot is improper. ③ Auxiliary feed shirring amount set value is improper. 	<ul style="list-style-type: none"> ○ Adjust the walking foot. ○ Make the height of the main walking foot and the auxiliary walking foot same. ○ Adjust the set value.
9. Feed pitch is not obtained.	<ol style="list-style-type: none"> ① Feed belt has been worn out. ② Walking foot is excessively raised. ③ Belt tension is too low. 	<ul style="list-style-type: none"> ○ Replace the belt. ○ Refer to "Adjusting the height of the walking foot". ○ Adjust to the proper tension value.
10. Shirring is not performed.	<ol style="list-style-type: none"> ① Feed belt has been worn out. ② Walking foot is excessively raised. ③ Belt tension is too low. ④ Set value is too small. 	<ul style="list-style-type: none"> ○ Replace the belt. ○ Refer to "Adjusting the height of the walking foot". ○ Adjust to the proper tension value. ○ Adjust to the optimum set value.
11. Shirring is excessively performed.	<ol style="list-style-type: none"> ① Set value is too large. 	<ul style="list-style-type: none"> ○ Adjust to the optimum set value.

26. DRAWING OF THE TABLE

Part No. : 40013092

26-1 Slant table

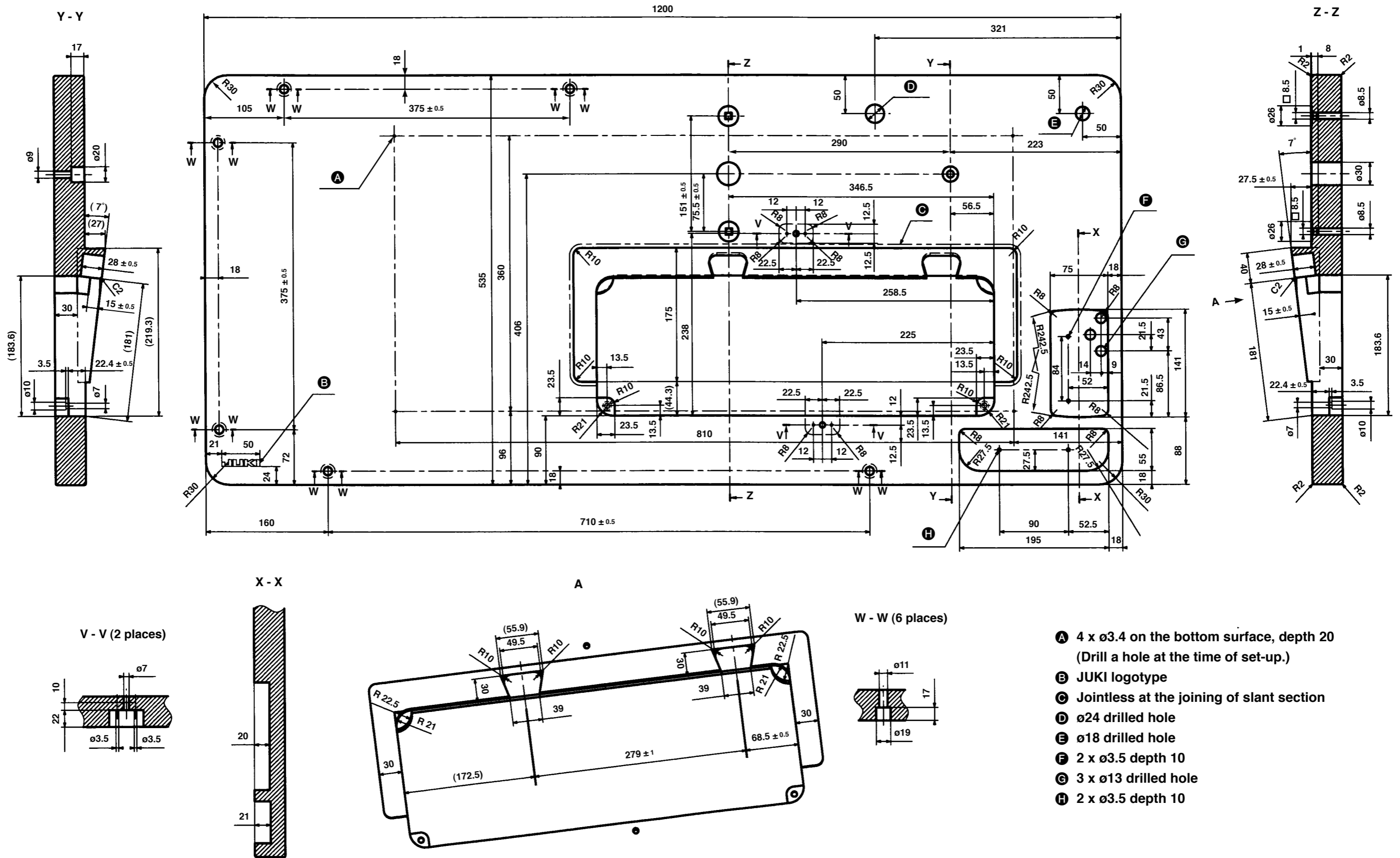

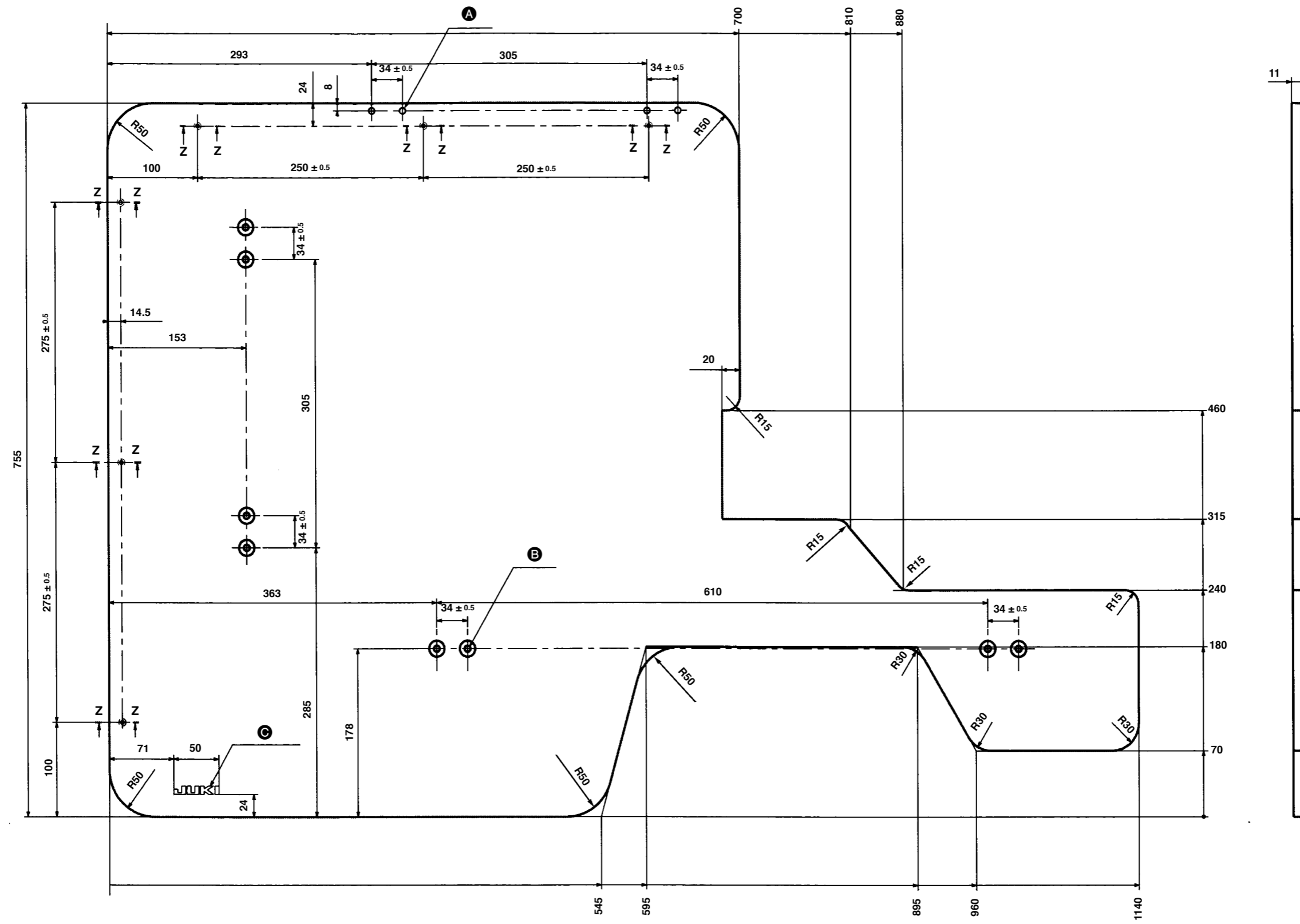

Z - Z (1:1) (6 places)

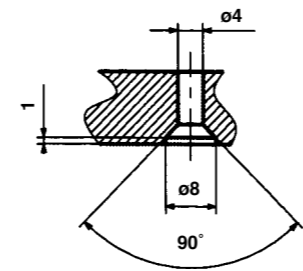

- Ⓐ 4 x 6.6 drill
- Ⓑ 8 x 6.6 drill, depth 17, spot facing depth 2
- Ⓒ JUKI logotype

