

PARTS LIST

DDL-900BB PARTS LIST

下記 URL (PARTS Website/PC サイト) より、便利な検索機能のついた Web Parts Book をご利用頂けます。
ご利用には会員登録が必要です。(無料)

<https://juki.aftama.com/JUKI/JA>

You can use a Web Parts Book with a convenient search function from the URLs (PARTS Website/PC-site)
below. To use the PARTS Website, free membership registration is required.

<https://juki.aftama.com/JUKI/EN>

HOW TO MAKE USE OF THIS PARTS LIST

1.Explanation of codes

1)"*"mark.....means this part is changed from the previous parts book.

As to the details of the change, refer to "List for information of change".

2)"#01".....refer to "Note" explanation at bottom of page.

2.Codes on the "Qty" column

• Each numeral indicates the number of parts required.

• "0.1" and "2.5" indicate the length (in meters) of the respective parts.

3.Parentheses mean that the corresponding part is a subpart that constructs an assembly part.

4.Dotted lines on the Figures indicate assembly parts.

5.As to the parts with marks of "☆"(consumable parts) and "◎"(optional parts)on the respective parts, it is recommended to prepare spares.

パーツリストご利用に際して

1."注記"欄の記号説明

1)"*"印..... 前回のパーツブックに比較して今回変更された部品を意味します。

変更内容は"変更情報リスト"を参照してください。

2)"#01"..... ページ下の"注記"の説明を参照してください。

2.数量欄の数字は、個数を表し、0.1、2.5等の数値は、長さ(単位メートル)を表します。

3.数量欄の()は、組部品を構成している子部品であることを意味します。

4.イラストページの-----枠は、組構成であることを意味します。

5.リストページの"☆"(消耗部品)、"◎"(オプション部品)の印がついた部品は、予備を準備しておくことをお奨めします。

CONTENTS

目次

1. FRAME & MISCELLANEOUS COVER COMPONENTS	1
頭部・外装関係	
2. BOBBIN WINDER COMPONENTS	3
糸巻装置関係	
3. MAIN SHAFT & THREAD TAKE-UP LEVER COMPONENTS	5
上軸・天秤関係	
4. NEEDLE BAR, UPRIGHT SHAFT & HOOK DRIVING SHAFT COMPONENTS	7
針棒・立軸・下軸関係	
5. HAND LIFTER COMPONENTS	9
押え上げ関係	
6. FEED MECHANISM COMPONENTS	11
送り関係	
7. THREAD TRIMMER COMPONENTS	13
糸切り装置関係	
8. AUTOMATIC REVERSE FEED COMPONENTS.....	15
自動逆送り関係	
9. CONDENSE COMPONENTS	16
コンデンス関係	
10. OIL LUBRICATION COMPONENTS.....	17
給油関係	
11. UNDER COVER COMPONENTS	19
アンダーカバー関係	
12. PSC UNIT.....	21
PSC ユニット	
13. THREAD STAND COMPONENTS.....	23
糸立装置関係	
14. ACCESSORIE PARTS COMPONENTS	25
付属品関係	
15. EXCLUSIVE PARTS FOR H.....	26
H 専用部品	
16. EXCLUSIVE PARTS TYPE NB.....	27
NB 仕様専用部品	
17. LIST FOR INFORMATION OF CHANGE.....	28
変更情報リスト	
NUMERICAL INDEX OF PARTS.....	29
索引	

1. FRAME & MISCELLANEOUS COVER COMPONENTS

頭部 · 外裝關係

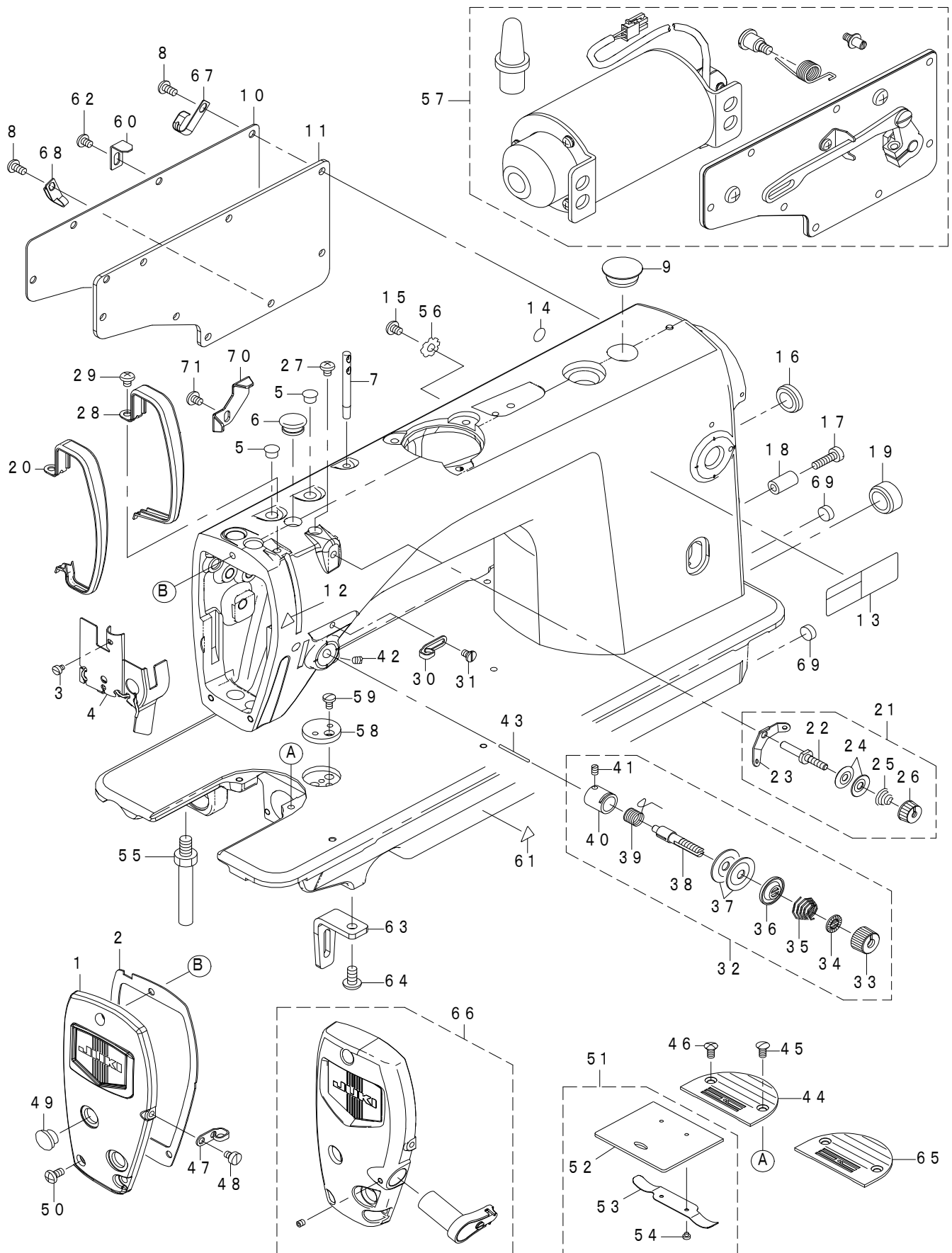

REF.NO	NOTE	PART NO	DESCRIPTION	品名	Qty
1		401-02097	FACE_PLATE_ASM.	面板(組)	1
2		400-12126	FACE PLATE PACKING	面板パッキン	1
3		SS-6080410-SP	SCREW 1/8-44 L=4	平ねじ 1/8-44 L=4	1
4		401-56677	ARM OIL SHIELD ASSY	面部油防板(組)	1
5		TA-0850604-R0	RUBBER PLUG	止め栓	2
6		TA-1250705-R0	RUBBER PLUG	止め栓	1
7		229-58300	NEEDLE THREAD GUIDE PIN	糸案内棒	1
8		SS-4120925-SP	SCREW 3/16-28 L=9	なべ小ねじ 3/16-28 L=9	8
9		TA-2100904-R0	RUBBER PLUG	止め栓	1
10		229-00401	WINDOW PLATE	窓板	1
11		400-12129	SIDE PLATE PACKING	窓板パッキン	1
12		CM-3002000-01	FINGER INJURY CAUTION LABEL (16)	指げが注意シール(16)	1
13		401-02261	SAFETY_LABEL_S	安全ラベル	1
14		229-01805	GROUND MARK	グラウンドマーク	1
15		SS-4120615-SP	SCREW 3/16-28 L=6	なべねじ 3/16-28 L=6	1
16		TA-2000502-R0	RUBBER PLUG	止め栓	1
17		SS-6121840-SP	SCREW 3/16-28 L=18	平ねじ 3/16-28 L=18	1
18		229-52501	BACK LEVER STOPPER	バックレバーストッパー	1
19		TA-2101002-R0	RUBBER PLUG	止め栓	1
20	#02	401-90685	THREAD TAKE UP LEVER COVER BB	天秤カバーBB向け	1
21		229-63458	THREAD TENSION ASM.	第一糸調子(組)	1
22		229-45414	THREAD TENSION POST	第一糸調子棒	(1)
23		229-45604	THREAD TENSION GUIDE	第一糸調子案内	(1)
24		229-45802	THREAD TENSION DISK	第一糸調子皿	(2)
25		229-63409	THREAD TENSION SPRING	第一糸調子ばね	(1)
26		229-45703	THREAD TENSION NUT	第一糸調子ナット	(1)
27		SS-4120615-SP	SCREW 3/16-28 L=6	なべねじ 3/16-28 L=6	1
28	#02	229-00609	THREAD TAKE-UP LEVER COVER	天秤カバー	1
29		SS-4120615-SP	SCREW 3/16-28 L=6	なべねじ 3/16-28 L=6	1
30		229-20508	ARM THREAD GUIDE A	アーム糸案内A	1
31		229-21001	SCREW	アーム糸案内A止めねじ	1
32		229-45356	THREAD TENSION ASM.	糸調子(組)	1
33		229-21308	THREAD TENSION NUT	糸調子ナット	(1)
34		229-21407	ROTATION STOPPER	糸調子皿回転止め	(1)
35		229-21704	THREAD TENSION SPRING A	糸調子ばね(A)	(1)
36		229-21803	DISK STOPPER	糸調子皿押え	(1)
37		229-21506	THREAD TENSION DISK	糸調子皿	(2)
38		229-21209	THREAD TENSION POST	糸調子棒	(1)
39	☆	229-21605	THREAD TAKE-UP SPRING	糸取りばね	(1)
40		229-45307	THREAD TENSION POST BASE	糸調子棒台	(1)
41		SS-8090670-SP	SCREW 9/64-40 L=5.5	止めねじ 9/64-40 L=5.5	(1)
42		SS-8150710-TP	SCREW 15/64-28 L=7	止めねじ 15/64-28 L=7	1
43		229-20904	TENSION RELEASING	糸緩めピン	1
44		B1109-552-000	THROAT PLATE	針板	1
45		SS-2110920-TP	SCREW 11/64-40 L=8.5	丸皿ねじ 11/64-40 L=8.5	1
46		SS-2110915-SP	SCREW 11/64-40 L=8.5	丸皿ねじ 11/64-40 L=8.5	1
47		229-20607	ARM THREAD GUIDE B	アーム糸案内 B	1
48		SS-6110610-TP	SCREW 11/64-40 L=6	平ねじ 11/64-40 L=6	1
49		TA-1250406-R0	RUBBER PLUG D=12.5 L=4	止め栓 D=12.5 L=4	2
50		SS-4120925-SP	SCREW 3/16-28 L=9	なべ小ねじ 3/16-28 L=9	3
51		229-01250	SLIDE PLATE ASM.	滑り板(組)	1
52		229-01201	SLIDE PLATE	滑り板	(1)
53		229-01300	SLIDE PLATE SPRING	滑り板ばね	(1)
54		SS-6060210-SP	SCREW 3/32-56 L=1.9	平ねじ 3/32-56 L=1.9	(2)
55		229-01003	BED SCREW STUD	ベッド支柱	3
56		WT-0530002-KS	TOOTHED WASHER D=5.3	歯付き座金 D=5.3	1
57	#01	401-88851	AK85B_DEVICE_900B	AK85B装置_900B	1
58		400-99083	RULER STOP SEAT	定規止め座	1
59		SS-7110720-SP	SCREW 11/64-40 L=7	丸平ねじ 11/64-40 L=7	1
60		401-26308	CORD_CLAMP	コード止金具	1
61		CM-3002000-01	FINGER INJURY CAUTION LABEL (16)	指げが注意シール(16)	1
62		SS-4120615-SP	SCREW 3/16-28 L=6	なべねじ 3/16-28 L=6	1
63		401-96832	BED_STD_R	ベッド支柱_R	1
64		SS-4151215-SP	SCREW 15/64-28 L=12	なべねじ 15/64-28 L=12	1
65	#01	401-82291	THROAT_PLATE_G	針板_G	1
66	#01	401-40080	FACE_PLATE_ASSY	面板組	1
67		401-36258	CORD HOLDER	コード押え	1
68		400-22407	CORD HOLDER	コード押え	1
69		TA-1030402-R0	RUBBER PLUG D=10.3 L=4	止め栓 D=10.3 L=4	2
70		401-11896	CORD_CLAMP	コード止金具(ワイパー無し)	1
71		SS-4120615-SP	SCREW 3/16-28 L=6	なべねじ 3/16-28 L=6	1

NOTE(注記)

#01....OPTIONAL PARTS

#02....VARIOUS NOS. FOR DESTINATIONS

オプション部品

仕向地による

2. BOBBIN WINDER COMPONENTS

糸巻装置関係

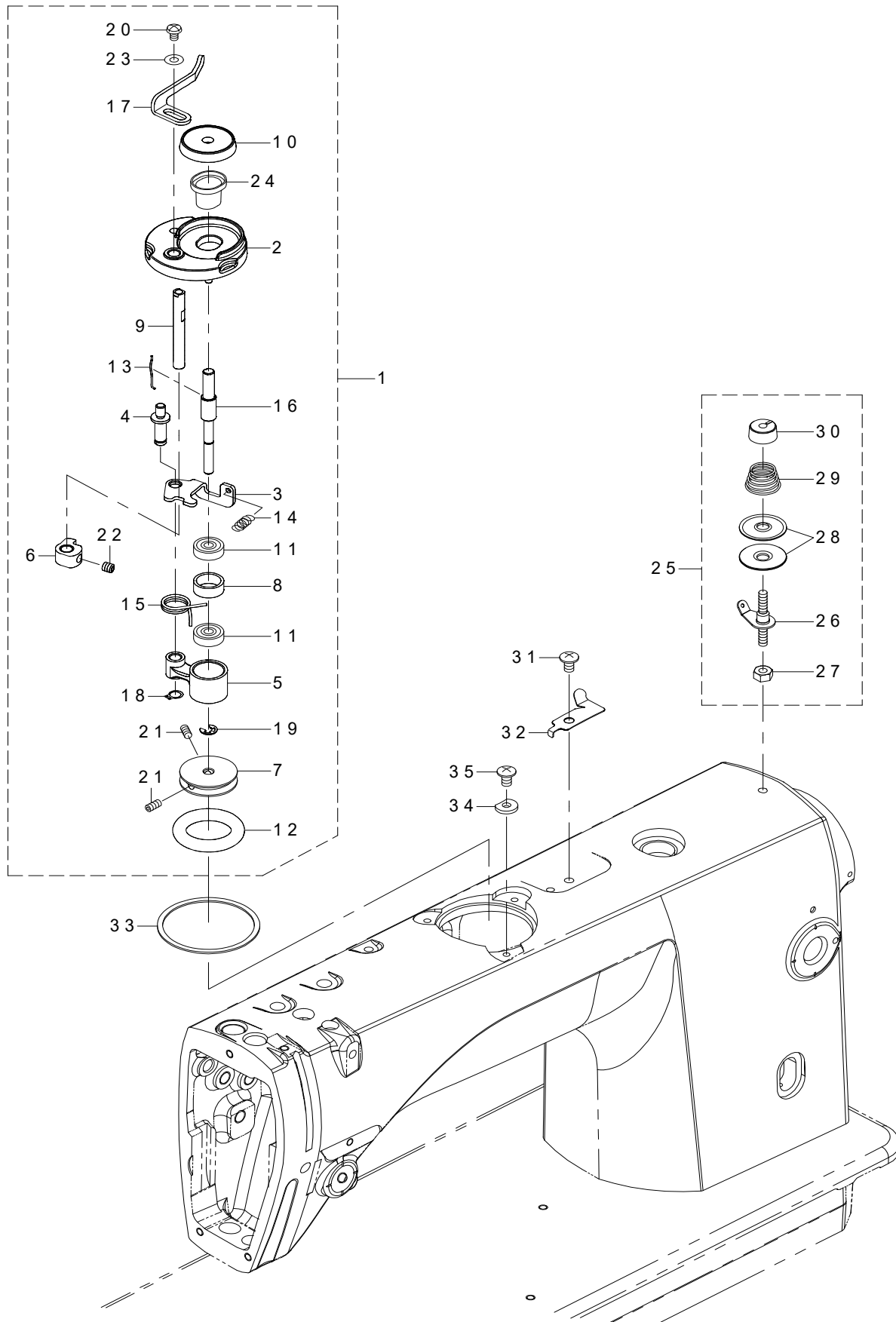

REF.NO	NOTE	PART NO	DESCRIPTION	品名	Qty
1		401-10976	BOBBIN_WINDER_UNIT	糸巻き装置結合	1
2		262-60109	BTW_BASE	糸巻き取付け台	(1)
3		262-60208	BTW_CAM_PLATE	糸巻き調節板	(1)
4		262-60307	BTW_BASE_SHAFT	糸巻き調節板軸	(1)
5		262-60406	BTW_SHAFT_BASE	糸巻き腕	(1)
6		262-60505	BTW_CAM_LEVER	糸巻きカム	(1)
7		262-60604	BTW_WHEEL	糸巻き車	(1)
8		262-60802	BTW_BEARING_SPACER	ベアリングスペーサー	(1)
9		262-61008	BTW_LEVER_SHAFT	糸巻きレバー軸	(1)
10		262-61206	BTW_SPACER	ボビン座	(1)
11		262-61305	BTW_BEARING	糸巻き軸ベアリング	(2)
12	☆	262-61503	BTW_WHEEL_RUBBER	糸巻き摩擦車	(1)
13	☆	262-61602	BOBBIN_SPRING	ボビン止めばね	(1)
14		262-61701	BTW_SPRING	糸巻き調節板戻しばね	(1)
15		400-11144	BTW_TORSION_SPRING	糸巻きねじりばね	(1)
16		401-10975	BTW_SHAFT	糸巻き軸	(1)
17		400-21933	BTW_LEVER	糸巻きレバー	(1)
18		RC-0560711-KP	RETAINING RING	C形止め輪	(1)
19		RE-0400000-K0	E-RING 4	E形止め輪 4	(1)
20		SM-5040655-SN	SCREW	バインドねじ	(1)
21		SM-8040802-TP	SCREW M4X8	止めねじ M4X0.7 L=8	(2)
22		SM-8050502-TP	SCREW M5 L=5	止めねじ	(1)
23		WP-0450826-SC	WASHER 4.5X10X0.8	平座金 4.5X10X0.8	(1)
24		401-19475	OIL_GUARD	オイルガード	(1)
25		401-10731	BOBBIN_THREAD_TENSION_ASSY	糸巻き糸調子(組)	1
26		401-10734	BOBBIN_THREAD_ROD_ASSY	糸巻き糸調子棒(結合)	(1)
27		NS-6120630-SP	NUT 3/16-28	六角ナット 3/16-28	(1)
28		229-21506	THREAD TENSION DISK	糸調子皿	(2)
29		D7133-555-B00	CONNECTING ROD SPRING	下連結棒ばね	(1)
30		229-45703	THREAD TENSION NUT	第一糸調子ナット	(1)
31		SM-0050801-SC	SCREW	トラスねじ M5 L=8	1
32		400-37008	THREAD_CUTTER	糸切り保持板	1
33		401-63521	PACKING	糸巻き取付け台パッキン	1
34		401-13241	BTW SPACER	下糸巻き装置スペーサ	1
35		SM-0050801-SC	SCREW	トラスねじ M5 L=8	3

3. MAIN SHAFT & THREAD TAKE-UP LEVER COMPONENTS

上軸・天秤関係

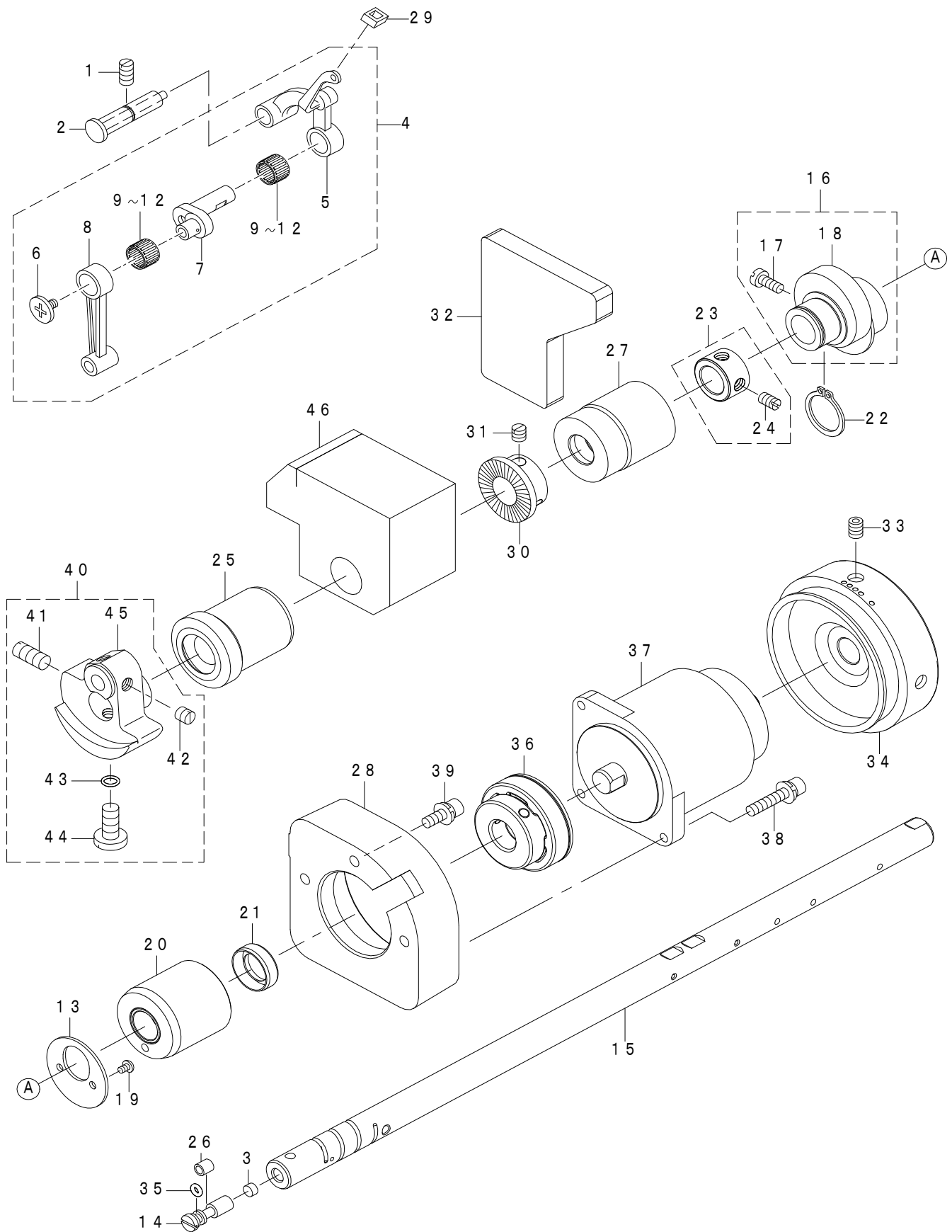

REF.NO	NOTE	PART NO	DESCRIPTION	品名	Qty
1		SS-8151150-TP	SCREW 15/64-28 L=10.5	止めねじ 15/64-28 L=10.5	1
2		229-19559	THREAD TAKE-UP CRANK SHAFT ASM.	天秤支え軸 (組)	1
3		110-02904	ROLLER FELT	面部油量調節フェルト	1
4		229-18072	THREAD TAKE-UP LEVER COMPL.	リンク天秤 (結合)	1
5		229-18064	THREAD TAKE-UP LEVER ASM.	リンク天秤 (組)	(1)
6		229-18304	LEFT SCREW	左ねじ	(1)
7		229-18106	NEEDLE BAR CRANK	針棒クランク	(1)
8		229-06606	NEEDLE BAR CRANK ROD	針棒クランクロッド	(1)
9	#01	229-18403	NEEDLE BEARING A	天秤ニードル軸受A	(2)
10	#01	229-18502	NEEDLE BEARING B	天秤ニードル軸受B	(2)
11	#01	229-18601	NEEDLE BEARING C	天秤ニードル軸受C	(2)
12	#01	229-18700	NEEDLE BEARING D	天秤ニードル軸受D	(2)
13		229-10103	THRUST COLLAR	送り偏心カムスラスト受	1
14		229-03900	ADJUSTING PIN	クランク油量調節ピン	1
15		401-10977	MAIN_SHAFT	上軸	1
16		229-10053	FEED DRIVE ECCENTRIC CAM ASM.	送り偏心カム (組)	1
17		SS-6661110-SP	SCREW 1/4-40 L=11	平ねじ 1/4-40 L=11	(2)
18		229-10004	FEED DRIVE ECCENTRIC CAM	送り偏心カム	(1)
19		SS-4090615-SP	SCREW 9/64-40 L=6	なべねじ 9/64-40 L=6	2
20		401-10978	MAIN_SHAFT_BUSHING	上軸後メタル	1
21		401-39216	OIL_SEAL	オイルシール	1
22		RC-1850001-KP	SNAP RING 18.5	C形止め輪 18.5	1
23		401-37504	THRUST_COLLAR_ASM	送り軸スラストカラー (組)	1
24		SS-8660610-TP	SCREW 1/4-40 L=6	止めねじ 1/4-40 L=6	(2)
25		229-03207	MAIN SHAFT BUSHING FRONT	上軸前メタル	1
26		B1215-552-000	OIL ADJUSTING COLLAR	クランク油量調節カラー	1
27		229-03306	BUSHING INTERMEDIATE	上軸中メタル	1
28		401-10979	MAIN_MOTOR_BASE_76	モーター取付台	1
29		229-19203	OIL PROTECTING RUBBER	天秤油切りゴム	1
30		225-38805	DRIVING WHEEL	糸巻き駆動車	1
31		SS-8660610-TP	SCREW 1/4-40 L=6	止めねじ 1/4-40 L=6	2
32		401-11424	FILTER	フィルター	1
33		SM-80608A2-TP	SCREW M6 L=8	六角穴付き止めねじ M6 L=8	2
34	*	402-00576	HAND_PULLEY	はずみ車	1
35		RO-0291801-00	RUBBER RING	Oリング	1
36		401-11025	COUPLING_ASM.	カップリング (組)	1
37		401-40419	SERVO MOTOR	サーボモータ	1
38		SL-6052592-TN	BOLT	座金付き六角穴ボルト	3
39		SL-6051492-TN	BOLT	座金付き六角穴ボルト	3
40		401-10390	COUNTER_WEIGHT_ASM.	釣合錘 (組)	1
41		SS-8681650-TP	SCREW 9/32-28 L=16	止めねじ 9/32-28 L=16	(1)
42		SS-8660610-TP	SCREW 1/4-40 L=6	止めねじ 1/4-40 L=6	(2)
43		RO-0442401-00	RUBBER RING	Oリング	(1)
44		SS-7681650-TP	SCREW 9/32-28 L=16	丸平ねじ 9/32-28 L=16	(1)
45		401-10376	COUNTER_WEIGHT	釣合錘	(1)
46		401-91470	FILTER	フィルター	1
		NOTE(注記)	#01....SELECTIVE PARTS	選択部品	

4. NEEDLE BAR, UPRIGHT SHAFT & HOOK DRIVING SHAFT COMPONENTS

針棒・立軸・下軸関係

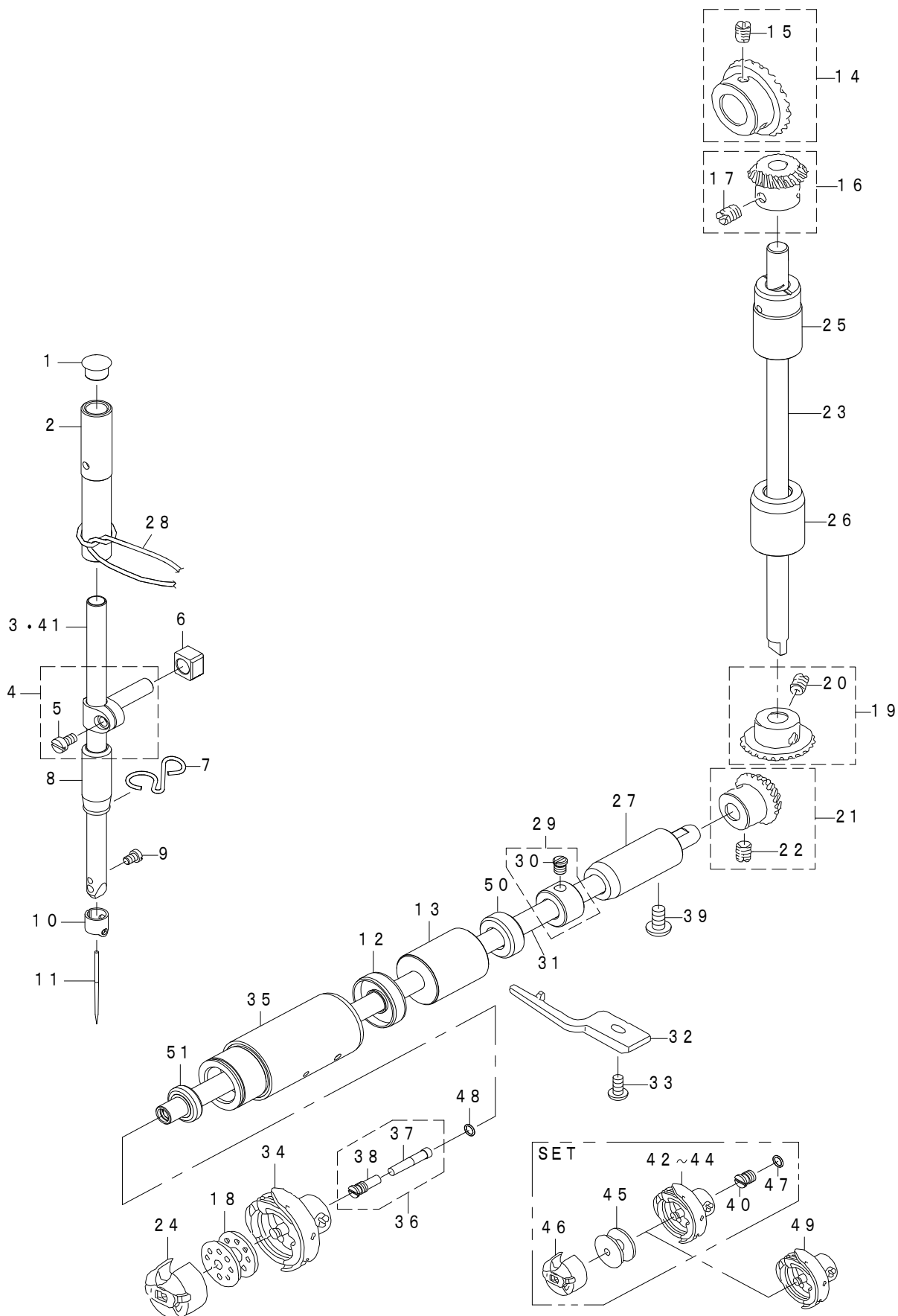

REF.NO	NOTE	PART NO	DESCRIPTION	品名	Qty
1		TA-0850604-R0	RUBBER PLUG	止め栓	1
2		229-06101	NEEDLE BAR BUSHING UPPER	針棒上メタル	1
3		229-39508	NEEDLE BAR	針棒	1
4		229-06457	NEEDLE BAR HOLDER ASM.	針棒抱き(組)	1
5		SS-6090670-TP	SCREW 9/64-40 L=6	平ねじ 9/64-40 L=6	(1)
6		400-90058	SLIDE BLOCK	針棒抱き案内コ口	1
7		401-41523	NEEDLE BAR THREAD GUIDE P	針棒糸案内	1
8		229-06200	NEEDLE BAR BUSHING LOWER	針棒下メタル	1
9	☆	SS-7080510-TP	SCREW 1/8-44 L=4.5	丸平ねじ 1/8-44 L=4.5	1
10		229-06309	NEEDLE BAR THREAD GUIDE	針棒糸掛け	1
11	☆	MDB-100B1400	NEEDLE DBX1 #14	針 DBX1 #14	1
12		236-20206	OIL SEAL	釜軸前オイルシール	1
13		401-84540	HOOK_SHAFT_MIDDLE_METAL	釜軸中メタル	1
14		400-90002	UPPER LARGE BEVEL GEAR ASM.	上傘歯車大(組)	1
15		SS-8660810-TP	SCREW 1/4-40 L=8	止めねじ 1/4-40 L=8	(2)
16		400-90003	UPPER SMALL BEVEL GEAR ASM.	上傘歯車小(組)	1
17		SS-8660810-TP	SCREW 1/4-40 L=8	止めねじ 1/4-40 L=8	(2)
18	☆	229-32909	BOBBIN	ボビン	1
19		400-90004	LOWER LARGE BEVEL GEAR ASM.	下傘歯車大(組)	1
20		SS-8660810-TP	SCREW 1/4-40 L=8	止めねじ 1/4-40 L=8	(2)
21		400-90005	LOWER SMALL BEVEL GEAR ASM.	下傘歯車小(組)	1
22		SS-8660810-TP	SCREW 1/4-40 L=8	止めねじ 1/4-40 L=8	(2)
23		229-05004	UPRIGHT SHAFT	立軸	1
24	☆	110-38759	BOBBIN CASE ASM.	ボビンケース(ばね入り)	1
25		229-05103	UPRIGHT SHAFT BUSHING UPPER	立軸上メタル	1
26		229-05202	UPRIGHT SHAFT BUSHING LOWER	立軸下メタル	1
27		229-16308	HOOK DRIVING SHAFT BUSH REAR	立軸後ろメタル	1
28		CQ-2200000-00	OIL WICK	油芯	0.3
29		401-36014	THRUST COLLAR ASM.	下軸スラスト受後ろ(組)	1
30		SS-6110420-TP	SCREW 11/64-40 L=4.8	平ねじ 11/64-40 L=4.8	(2)
31		401-27192	HOOK_DRIVING_SHAFT	釜軸	1
32		401-74351	INNER_HOOK HOLDER	中釜押え	1
33		SS-6111210-SP	SCREW 11/64-40 L=12	平ねじ 11/64-40 L=12	1
34	☆	110-38650	HOOK ASM.	給油釜(組)	1
35		401-90562	HOOK_SHAFT_FRONT_METAL_ASM	釜軸前メタル(組)	1
36	☆	229-16555	OIL SEAL SCREW ASM.	下軸前止めねじ(組)	1
37		110-15906	OIL WICK	下軸前止めねじ油芯	(1)
38		229-16506	SET SCREW	下軸前止めねじ	(1)
39		SS-4120925-SP	SCREW 3/16-28 L=9	なべ小ねじ 3/16-28 L=9	1
40	#01	110-79506	FRONT SCREW	下軸前止めねじ	1
41	#02	229-39607	NEEDLE BAR B	針棒 B	1
42	☆	#01 228-90404	RP HOOK C	RP釜C	1
43	☆	#01 228-90206	RP HOOK	RP釜	1
44	☆	#01 228-90305	RP HOOK S	RP釜S	1
45	☆	#01 B9117-552-A00	BOBBIN	ボビン	1
46	☆	#01 228-96252	BOBBIN CASE ASM.	ボビンケース(組)	1
47	#01	RO-0360802-00	RUBBER RING	Oリング	1
48		RO-0360802-00	RUBBER RING	Oリング	1
49	#01	401-26849	HOOK ASM.	給油釜(組)	1
50		400-86744	HOOK DRIVING SHAFT OIL SEAL	釜軸オイルシール	1
51		400-10805	OIL SEAL RING	オイルシール	1

NOTE(注記)

#01.....OPTIONAL PARTS

#02.....ACCORDING TO DESTINATIONS

オプション部品

仕向地による

5. HAND LIFTER COMPONENTS

押え上げ関係

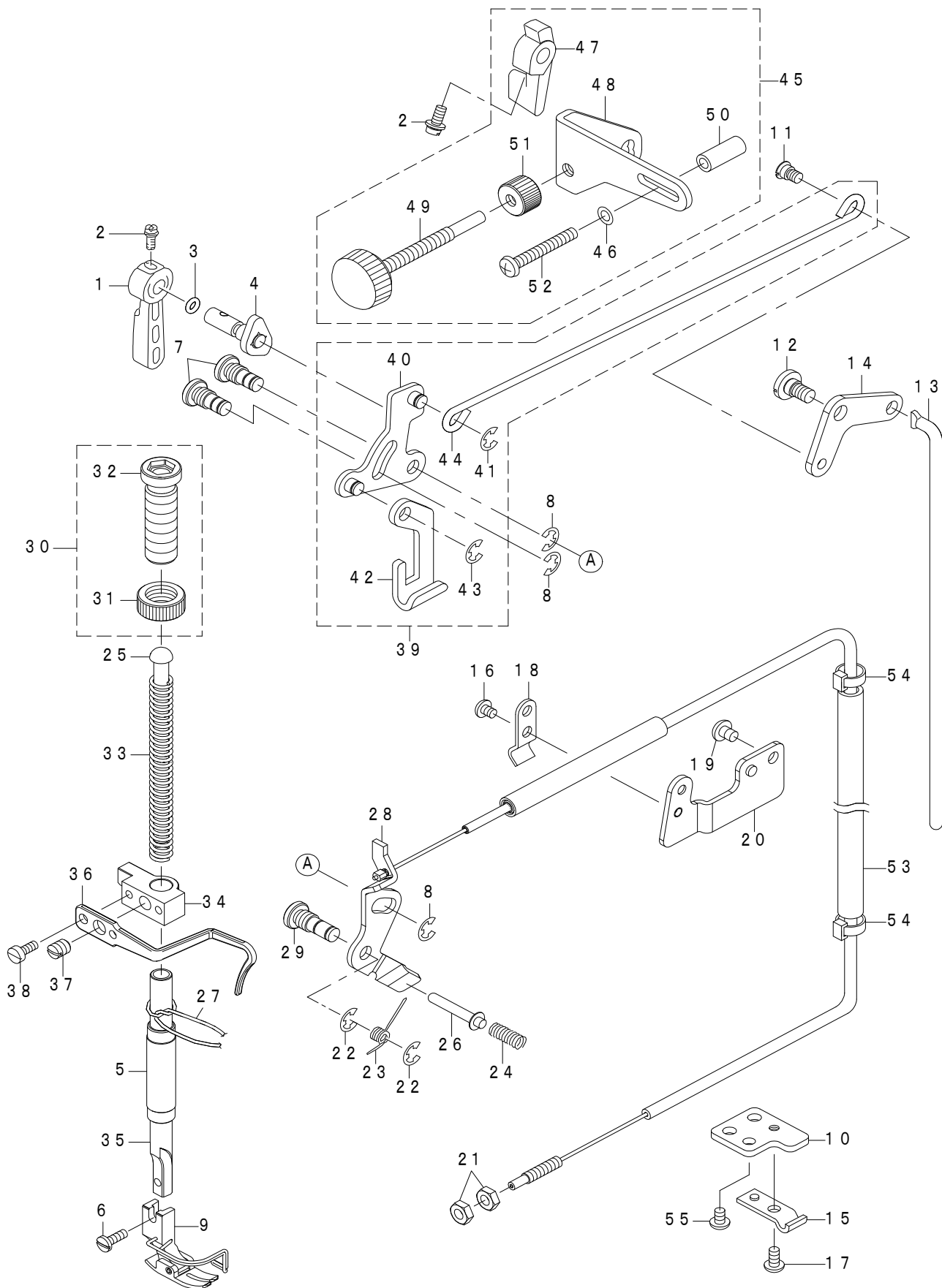

REF.NO	NOTE	PART NO	DESCRIPTION	品名	Qty
1		229-07802	HAND LIFTER	押え上げレバー	1
2		B1521-555-000	SCREW	押え上げレバー止めねじ	1
3		RO-0371801-00	RUBBER RING	Oリング	1
4		229-08552	HAND LIFTER CAM ASM.	押え上げカム (組)	1
5		400-60989	PRESSER BAR BUSHING LOWER	押え棒下メタル	1
6	☆	SS-7091110-TP	SCREW 9/64-40 L=10.5	丸平ねじ 9/64-40 L=10.5	1
7		229-08701	LINK SHAFT	引き上げリンク軸	2
8		RE-0500000-K0	E-RING	E形止め輪 5	3
9		B1524-012-0BA	PRESSER FOOT ASM.	自由押え (針ガード付き) (組)	1
10		400-50314	OUTER HOLDER_BASE	アウター押さえ土台	1
11		229-08909	HINGE SCREW	膝上げ横棒段ねじ	1
12		SD-0720331-SP	HINGE SCREW D=7.24 H=3.3	段ねじ D=7.24 H=3.3	1
13		229-09006	KNEE LIFTER CONNECTING ROD	膝上げ連結棒	1
14		229-08800	KNEE LIFTER LINK	膝上げリンク	1
15		D3164-555-B00	OUTER PRESSER PLATE	アウター押え	1
16		SS-4110515-SP	SCREW 11/64-40 L=5	なべねじ 11/64-40 L=5	1
17		SM-4050855-SP	SCREW	なべねじ M5 L=8	1
18		401-86696	WIRE HOLDER	ワイヤー押え	1
19		SS-4120615-SP	SCREW 3/16-28 L=6	なべねじ 3/16-28 L=6	1
20		401-87308	WIRE PRESSER BASE	ワイヤー押え台	1
21		NS-6620310-SP	NUT 3/16-32	六角ナット 3/16-32	2
22		RE-0500000-K0	E-RING	E形止め輪 5	2
23		229-20201	RETURN SPRING	糸緩め板戻しばね	1
24		229-20409	THREAD RELEASE PIN SPRING	糸緩めピンばね	1
25		229-07703	PRESSER GUIDE BAR	押え案内棒	1
26		229-20300	THREAD RELEASE SUPPORTING PIN	糸緩め補助ピン	1
27		CQ-2020000-00	OIL WICK	油芯	0.15
28		401-84541	THREAD_RELEASE_WIRE_ASM	糸緩めワイヤー(組)	1
29		229-20102	TENSION RELEASE SHAFT	糸緩め板軸	1
30		229-07554	PRESSER SPRING REGULATOR ASM.	送り調節ねじナット (組)	1
31		229-07604	PRESSER SPRING REGULATOR NUT	押え調節ねじナット	(1)
32		229-07505	PRESSER SPRING REGULATOR	押え調節ねじ	(1)
33		229-07406	PRESSER SPRING	押え調節ばね	1
34		400-98388	PRESSER BAR GUIDE BRACKET	押え棒抱き	1
35		400-17805	PRESSER BAR	押え棒	1
36		229-07307	THREAD GUIDE	押え棒抱き系案内	1
37		SS-8660810-TP	SCREW 1/4-40 L=8	止めねじ 1/4-40 L=8	1
38		SS-6090910-SP	SCREW 9/64-40 L=9	平ねじ 9/64-40 L=9	2
39		229-08354	KNEE LIFTING CROSS ROD ASM.	膝上げ横棒 (組)	1
40		229-08156	LIFTING LINK ASM.	引き上げリンク (組)	(1)
41		RE-0500000-K0	E-RING	E形止め輪 5	(1)
42		229-08008	LIFTING PLATE	引き上げ板	(1)
43		RE-0500000-K0	E-RING	E形止め輪 5	(1)
44		229-08305	KNEE LIFTER SIDE ROD	膝上げ横棒	(1)
45	#01	112-43763	PRESSER LIFTING DEVICE ASM.	微量押え上げ装置 (組)	1
46		WP-0482086-SD	WASHER 4.8X11.5X2	平座金 4.8X11.5X2	(1)
47		236-11106	HAND LIFTER	押え上げレバー	(1)
48		112-44209	STOPPER BASE	ストッパー台	(1)
49		236-10652	STOPPER SCREW ASM.	ストッパーねじ (組)	(1)
50		112-44019	STOPPER COLLAR	ストッパーカラー	(1)
51		236-10702	STOPPER SCREW NUT	ストッパーねじナット	(1)
52		114-33802	SET SCREW	止めねじ	(1)
53		BT-1000651-EB	POLYURETHANE TUBE	ポリウレタンチューブ	0.22
54		HX-0006500-0A	CABLE CLIP	束線バンド	2
55		SM-4040885-SP	SCREW	なべねじ	1
		NOTE(注記)	#01....OPTIONAL PARTS	オプション部品	

6. FEED MECHANISM COMPONENTS

送り関係

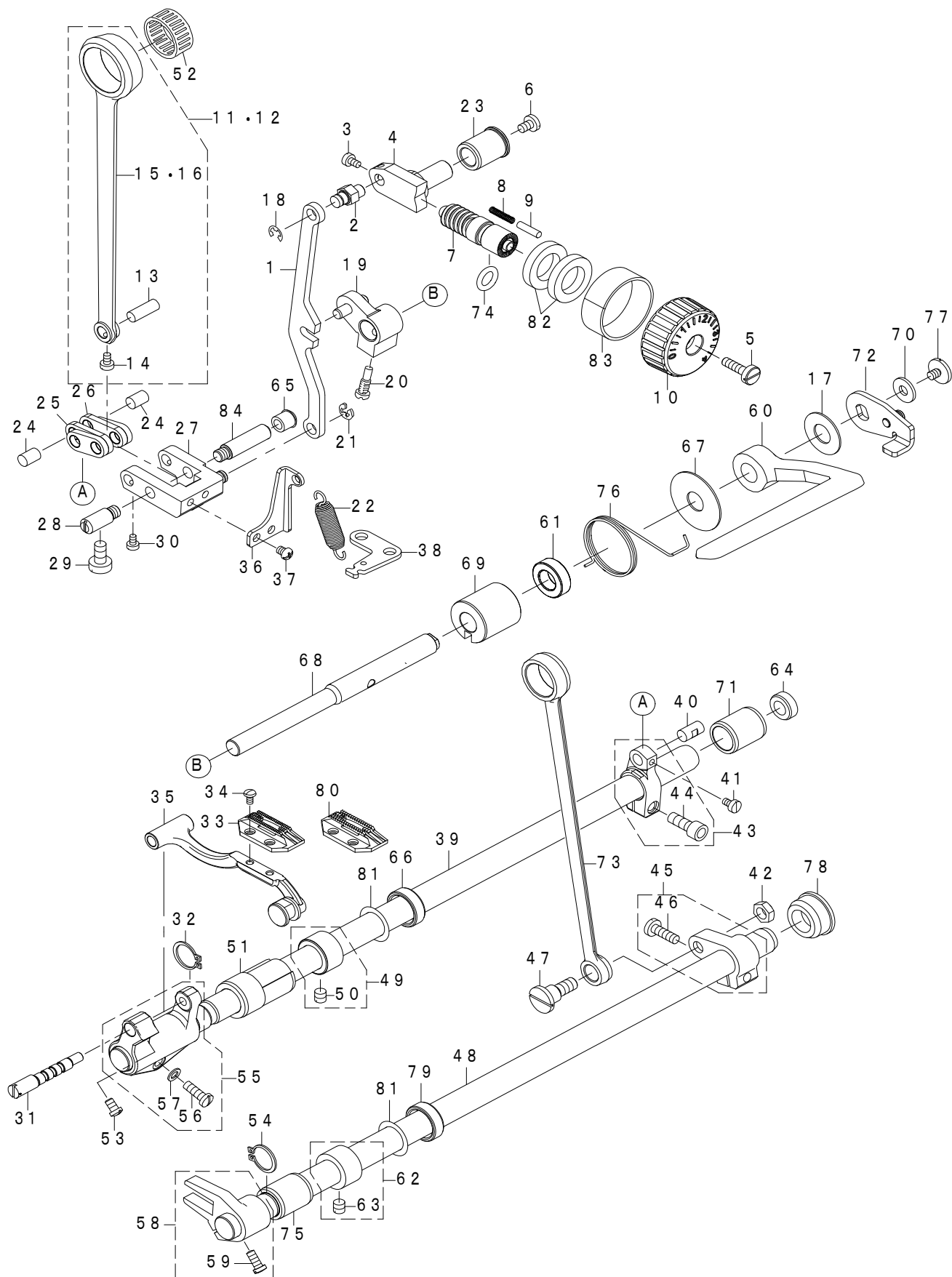

REF.NO	NOTE	PART NO	DESCRIPTION	品名	Qty
1		229-11408	FEED REGULATOR CONNECTING ROD	送り調節ロッド	1
2		229-11507	WALKING FOOT PIN C	送り調節台ピン	1
3		SS-6090670-TP	SCREW 9/64-40 L=6	平ねじ 9/64-40 L=6	2
4		229-11606	FEED REGULATOR	送り調節台	1
5		SS-6121860-SP	SCREW 3/16-28 L=18	平ねじ 3/16-28 L=18	1
6		SS-7120770-SH	SCREW 3/16-28 L=7	丸平ねじ 3/16-28 L=7	1
7		229-11804	FEED REGULATOR SCREW	送り調節ねじ	1
8		229-12109	FEED REGULATOR PIN SPRING	送り調節ピンばね	1
9		229-12000	FEED REGULATOR PIN	送り調節ピン	1
10		229-40506	FEED DIAL	送りダイヤル	1
11		229-10251	CONNECTING ROD ASM.	水平送りロッド(組)	1
12	#01	229-13859	ROCKER SHAFT CONNECTING ROD B ASM.	水平送りロッドB(組)	1
13		229-11101	WALKING FOOT PIN C	水平送りピンC	(1)
14		SS-6090620-TP	SCREW	平ねじ	(1)
15		229-10202	ROCKER SHAFT CONNECTING ROD	水平送りロッド	(1)
16	#01	229-13800	ROCKER SHAFT CONNECTING ROD B	水平送りロッドB	(1)
17		138-87005	THRUST WASHER	スラストワッシャ	1
18		RE-0500000-K0	E-RING	E形止め輪 5	1
19		229-12257	FEED REVERSE ARM ASM.	送りレバー腕(組)	1
20		229-12505	FEED REVERSE ARM SCREW	送りレバー腕止めねじ	1
21		RE-0500000-K0	E-RING	E形止め輪 5	1
22		110-37405	SPRING	調節リンクばね B	1
23		110-09800	FEED REGULATOR BUSHING	送り調節台メタル	1
24		229-10905	WALKING FOOT PIN A	水平送りピンA	2
25		400-89548	CONNECTING LINK B	連結リンクB	2
26		400-93417	CONNECTING LINK A	連結リンクA	2
27		229-10459	FEED ADJUSTING LINK ASM.	送り調節リンク(組)	1
28		229-10806	ADJUST LINK FULCRUM SHAFT A	調節リンク支点軸A	1
29		SS-6151220-SP	SCREW 15/64-28 L=11.5	平ねじ 15/64-28 L=11.5	2
30		SS-6090620-TP	SCREW	平ねじ	2
31		401-25485	FEED_BASE_SHAFT	送り台軸	1
32		RC-0150001-KP	RETAINING RING 13.8	C形止め輪 13.8	1
33		B1613-012-I00	FEED DOG 1	送り歯 1	1
34		SS-4080620-TP	SCREW 1/8-44 L=6	なべねじ 1/8-44 L=6	2
35		229-40753	FEED BAR ASM.	送り台(組)	1
36		229-41306	REGULATOR LINK SPRING HOOK	調節リンクばね掛け	1
37		SS-4110515-SP	SCREW 11/64-40 L=5	なべねじ 11/64-40 L=5	2
38		229-13701	FEED SPRING HOOK	送りばね掛け	1
39		401-56684	FEED ROCKER SHAFT	水平送り軸	1
40		229-11002	WALKING FOOT PIN B	水平送りピンB	1
41		SS-6090620-TP	SCREW	平ねじ	1
42		NS-6680410-SP	NUT 9/32-28	六角ナット 9/32-28	1
43		401-10379	ASSY_FEED_ROCKER_ARM	水平送り腕(組)	1
44		SS-6121610-SP	SCREW 3/16-28 L=15.5	平ねじ 3/16-28 L=15.5	(1)
45		401-09422	FEED_ARM_ASM	上下送り腕(組)	1
46		SS-7121610-SP	SCREW 3/16-28 L=15.5	丸平ねじ 3/16-28 L=15.5	(1)
47		SD-1000801-SH	HINGE SCREW D=10 H=8	段ねじ D=10 H=8	1
48		401-86644	FEED_DRIVING_SHAFT	上下送り軸	1
49		401-37504	THRUST_COLLAR_ASM	送り軸スラストカラー(組)	1
50		SS-8660610-TP	SCREW 1/4-40 L=6	止めねじ 1/4-40 L=6	(2)
51	#01	401-84536	FEED_ROCKER_SHAFT_METAL	水平送り軸メタル	1
52		401-11897	BEARING	水平送りロッドベアリング	1
53		SS-7110740-TP	SCREW 11/64-40 L=7	丸平ねじ 11/64-40 L=7	1
54		RC-0150001-KP	RETAINING RING 13.8	C形止め輪 13.8	1
55		229-40654	FEED ROCKER ASM.	送り台腕(組)	1
56		SS-7121410-TP	SCREW 3/16-28 L=14	丸平ねじ 3/16-28 L=14	(1)
57		WP-0480856-SP	WASHER 4.8X8.4X0.8	平座金 4.8X8.4X0.8	(1)
58		229-15359	DRIVING SHAFT CRANK ASM.	上下送り二又(組)	1
59		SS-7111120-SP	SCREW 11/64-40 L=10.5	丸平ねじ 11/64-40 L=10.5	(1)
60		401-84533	FEED LEVER	送りレバー	1
61		228-88507	OIL SEAL	送りレバー軸オイルシール	1
62		401-37504	THRUST_COLLAR_ASM	送り軸スラストカラー(組)	1
63		SS-8660610-TP	SCREW 1/4-40 L=6	止めねじ 1/4-40 L=6	(2)
64		401-56758	FEED SHAFT RUBBER	送り軸止め栓	2
65		TA-0950806-R0	RUBBER PLUG	止め栓	1
66		400-29963	OIL SEAL	水平送り軸オイルシール	1
67		401-86209	THRUST_WASHER_B	スラストワッシャB	1
68		401-84531	REVERSE_FEED_LEVER_SHAFT	送りレバー軸	1
69		401-84535	REVERSE_FEED_LEVER_SHAFT_METAL	送りレバー軸メタル	1
70		WP-0611626-SP	WASHER 15X6X1.6	平座金	1
71		228-87905	BUSHING,REAR	送り軸後ろメタル	1
72		401-90446	ASSY_CONDENSE_LINK	コンデンスリンク組	1
73		229-15003	CONNECTING ROD	上下送りロッド	1
74		RO-0922702-00	RUBBER RING	Oリング	1
75		229-13008	FEED ROCKER SHAFT BUSHING	上下送り軸前メタル	1
76		401-84537	REVERSE_FEED_LEVER_SPRING	送りレバーばね	1
77		SS-7620750-SP	SCREW 3/16-32 L=6.5	丸平ねじ 3/16-32 L=6.5	1
78		TA-2351004-R0	RUBBER PLUG	止め栓	1
79		400-29963	OIL SEAL	水平送り軸オイルシール	1
80	#01	401-33950	FEED_DOG_M	送り歯	1
81		RO-1331701-00	RUBBER RING	Oリング	2
82		229-53400	RUBBER PLUNGER	プランジャーゴム	2
83		401-90682	RUBBER	ラバー	1
84		400-10395	ADJUSTING LINK FULCRUM SHAFT B	調節リンク支点軸B	1
		NOTE(注記)	#01....ACCORDING TO DESTINATIONS	仕向地による	

7. THREAD TRIMMER COMPONENTS

糸切り装置関係

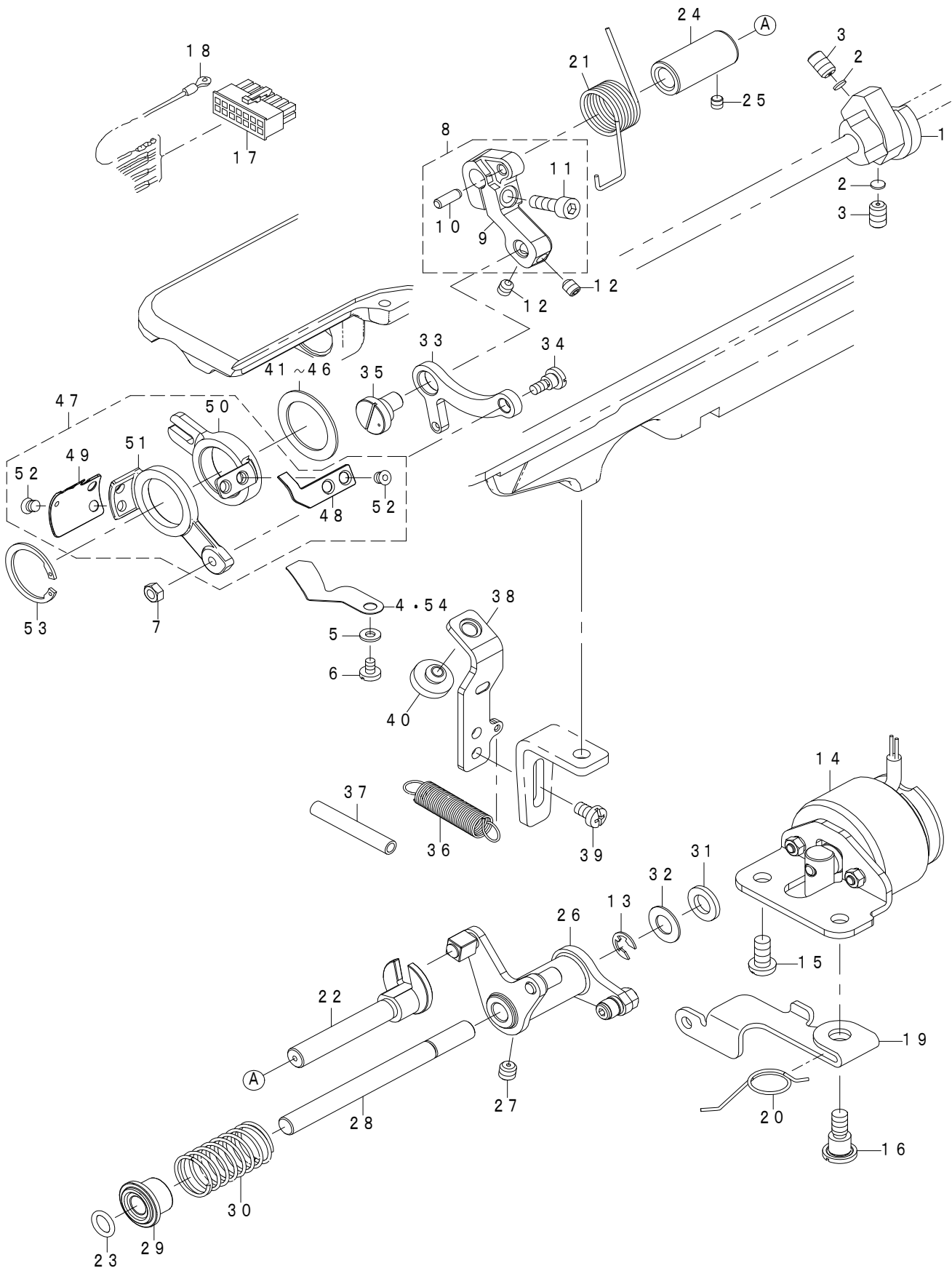

REF.NO	NOTE	PART NO	DESCRIPTION	品名	Qty
1		401-96923	THREAD_TRIMMER_CAM	糸切りカム	1
2		401-27153	SPACER	スペーサ	2
3		SS-8661012-TP	SCREW	止めねじ	2
4	☆	#02 401-90553	LOWER THREAD FINGER	糸さばき板	1
5		WP-0371016-SD	WASHER 3.7X8X1	平座金 3.7X8X1	1
6		SS-7090610-SP	SCREW 9/64-40 L=6	丸平ねじ 9/64-40 L=6	1
7		NM-6040001-SC	NUT M4X0.7 TYPE1	六角ナット M4X0.7 1種	1
8		401-94939	ASSY THREAD TRIMMER ARM	糸切り腕 (組)	1
9		401-90558	THREAD_TRIMMER_ARM	糸切り腕	(1)
10	☆	401-72479	THREAD_TRIMMER_ARM_PIN	糸切り腕ピン	(1)
11		SM-6051602-TP	SCREW M5X0.8 L=16	六角穴ボルト M5X0.8 L=16	(1)
12		SM-80506A2-TP	SCREW M5 L=6	六角穴付き止めねじ M5 L=6	2
13		RE-0600000-K0	E-RING 6	E形止め輪 6	1
14		401-86203	THREAD_TRIMMER_SOLENOID_ASM	糸切りソレノイド (組)	1
15		SS-4151215-SP	SCREW 15/64-28 L=12	なべねじ 15/64-28 L=12	1
16		SD-0850751-SP	HINGE SCREW D=8.50 H=7.5	段ねじ D=8.5 H=7.5	1
17		HK-0346101-40	HOUSING 14P	ハウジング 14P	1
18		401-12907	GROUND WIRE ASM	アースコード (組)	1
19		401-84558	THREAD_RELEASE_LEVER	糸緩め腕	1
20		401-27190	RETURN_SPRING	糸緩め戻しばね	1
21		401-27164	SPRING	ばね	1
22		401-87734	FORKED_SHAFT	糸切り二又軸	1
23		RO-0781901-00	RUBBER_RING	Oリング	1
24		401-84557	FORKED_SHAFT_BUSH	糸切り二又軸メタル	1
25		SS-8110422-TP	SCREW 11/64-40 L=4	止めねじ 11/64-40 L=4	1
26		401-27168	THREAD_TRIMMER_CAM_LEVER_ASSY	糸切りカム腕 (組)	1
27		SS-8660612-TP	SCREW 1/4-40 L=6	止めねじ 1/4-40 L=6	1
28		401-27180	THREAD_TRIMMER_CAMLEVER_SHAFT	糸切りカム腕軸	1
29		401-87306	THREAD_TRIMMER_SPRING_COLLAR	糸切りばねカラー	1
30		401-27182	SPRING	糸切りカム腕ばね	1
31		401-27183	CUSHION	糸切りカム腕ゴム	1
32		WP-0820816-SD	WASHER 8.2X16X0.8	平座金 8.2X16X0.8	1
33		401-90557	THREAD_TRIMMER_ROD	糸切り連結ロッド	1
34		SD-0600406-TP	SHOULDER SCREW	段ねじ D=6 H=4	1
35		401-72480	TRIMMER_ADJUSTINGT_PIN	糸切り調節ピン	1
36		401-90559	TRIMMER_BACK_SPRING	糸切り戻しばね	1
37		401-78658	PIPE	パイプ	0.04
38		401-96831	RUBBER_STOPPER_PLATE	ストッパー板	1
39		SM-4050855-SP	SCREW	なべねじ M5 L=8	2
40		B1116-210-D00	FRAME_SUPPORT_RUBBER	頭部支えゴム	1
41	#01	114-19504	THRUST_COLLAR, A	スラスト受 A	1
42	#01	114-19603	THRUST_COLLAR, B	スラスト受 B	1
43	#01	114-19702	THRUST_COLLAR, C	スラスト受 C	1
44	#01	114-19801	THRUST_COLLAR, D	スラスト受 D	1
45	#01	114-19900	THRUST_COLLAR, E	スラスト受 E	1
46		401-74612	SPACER	スペーサー	1
47		401-94932	KNIFE_UNIT	メスユニット	1
48	☆	401-95552	THREAD_TRIMMER_KNIFE_H	糸切りメスH	(1)
49	☆	401-95289	MOVING_KNIF	糸さばきメス	(1)
50		401-90556	THREAD_TRIMMER_BASE	糸切り土台	(1)
51		401-90555	MOVING_KNIFE_BASE	動メス土台	(1)
52	☆	114-20601	SCREW	メス止めねじ	(4)
53		RC-2651218-KP	RETAINING_RING	C形 止め輪	1
54	*	402-00018	LOWER_THREAD_FINGER	糸さばき板	1
		NOTE(注記)	#01.....SELECTIVE PARTS #02.....TYPE H	選択部品 H仕様	

8. AUTOMATIC REVERSE FEED COMPONENTS

自動逆送り関係

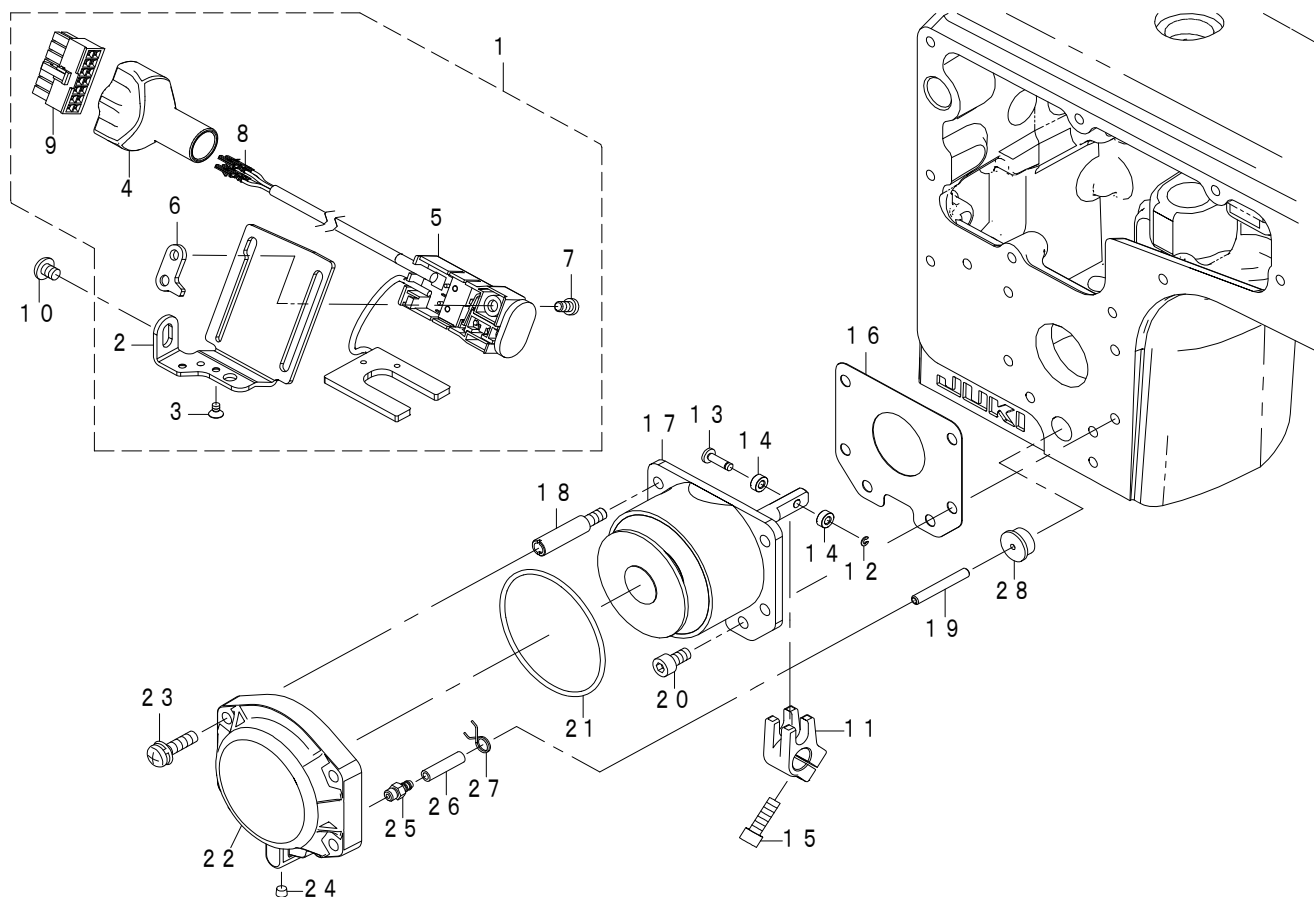

REF.NO	NOTE	PART NO	DESCRIPTION	品名	Qty
1	☆	401-48382	LED_BT_SWITCH_ASSY	LED逆送りスイッチ組	1
2		401-39771	LED_BASE	LED板金	(1)
3		401-40191	LED_SCREW	LED固定ねじ	(2)
4		401-40306	CONNECTOR_COVER	コネクタカバー	(1)
5		401-49069	LED_BT_SWITCH	LED逆送りスイッチ	(1)
6		236-32102	REVERSE FEED SWITCH BASE GUIDE	逆送りスイッチ台ガイド	(1)
7		SS-7110740-TP	SCREW 11/64-40 L=7	丸平ねじ 11/64-40 L=7	(1)
8		HK-0346400-0B	PIN CONTACT	ピンコンタクト	(4)
9		HK-0346101-40	HOUSING 14P	ハウジング 14P	(1)
10		SS-4120615-SP	SCREW 3/16-28 L=6	なべねじ 3/16-28 L=6	1
11		401-84562	REVERSE_FEED_ARM	自動バック駆動腕	1
12		RC-0260415-K0	C-RING	C形止め輪	1
13		112-17114	ROLLER SHAFT	上下棒コロ軸	1
14		112-17213	ROLLER	上下棒コロ	2
15		SM-6051602-TP	SCREW M5X0.8 L=16	六角穴ボルト M5X0.8 L=16	1
16		401-84560	REVERSE_FEED_SOLENOID_PACKING	逆送りソレノイドパッキン	1
17		401-98464	REVERSE_FEED_SOLENOID	逆送りソレノイド	1
18		401-87304	STUD	スタッド	4
19		401-86847	REVERSE FEED SOLENOID PIPE	逆送りソレノイドパイプ	1
20		SM-6051002-TP	SCREW M5X0.8 L=10	六角穴ボルト M5X0.8 L=10	2
21		RO-5552002-00	O-RING	Oリング	1
22		401-87307	SOLENOID CAP	ソレノイドキャップ	1
23		SL-4052091-SC	SCREW M5X0.8 L=20	なべ小ねじセムス M5X0.8 L=20	4
24		TA-0400301-M0	PLUG D=4X4.5 L=3	止め栓 D=4X4.5 L=3	1
25		SQ-2050453-MZ	CONNECTING SCREW	パイプ連結ねじ	1
26		236-30007	TUBE	チューブ	0.02
27		236-29306	PIPE STOPPER A	パイプ止めA	1
28		B3510-205-000	RUBBER PLUG	針棒止め栓	1

9. CONDENSE COMPONENTS

コンデンス関係

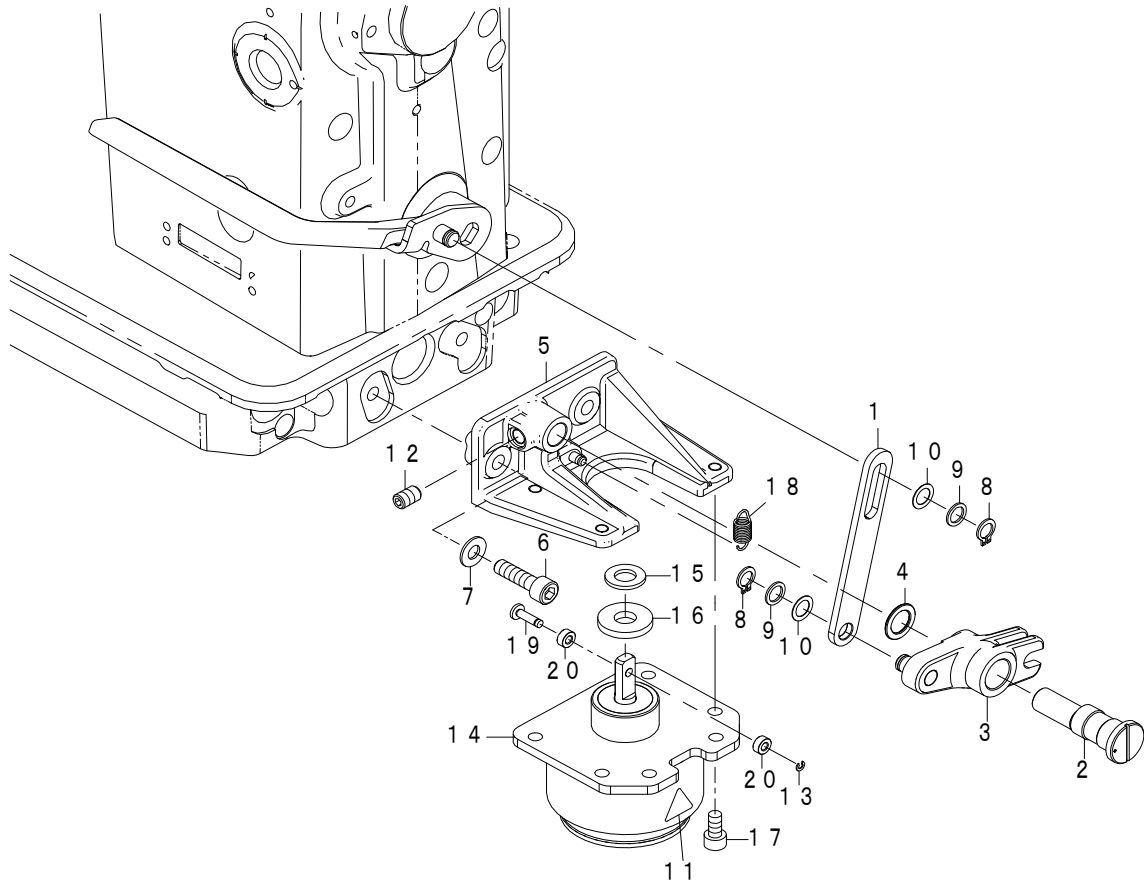

REF.NO	NOTE	PART NO	DESCRIPTION	品名	Qty
1		401-90435	CONDENSE ROD	コンデンスロッド	1
2		401-90440	CONDENSE ARM SHAFT	コンデンス駆動腕軸	1
3		401-90450	ASSY CONDENSE ARM	コンデンス腕組	1
4		101-09700	THRUST WASHER, A	スラスト板 A	1
5		401-94934	ASSY CONDENSE BASE	コンデンス土台組	1
6		SM-6062502-TP	SCREW M6 L=25	六角穴ボルト M6 L=25	2
7		WP-0641600-SC	WASHEW 6.4X12.5X1.6	平座金	2
8		RC-0650811-KP	C-RING 7(6.5)	C形止め輪7 (6.5)	2
9		400-90529	TAKE_UP_CRANK_SHAFT_WASHER_B	天秤支え軸座金B	2
10		WP-0720316-RZ	WASHER 7.2X11X0.25	平座金 7.2X11X0.25	2
11		CM-3003000-01	SEAL	高温注意シール (16)	1
12		SS-8661012-TP	SCREW	止めねじ	1
13		RC-0260415-K0	C-RING	C形止め輪	1
14		401-90444	CONDENSE SOLENOID	コンデンスソレノイド	1
15		WP-0841600-SD	WASHER M8	平座金小形丸, M8	1
16		D6056-555-B00	RUBBER CUSHION (B)	取付ゴム座	1
17		SM-6051002-TP	SCREW M5X0.8 L=10	六角穴ボルト M5X0.8 L=10	4
18		401-90451	CONDENSE SPRING	コンデンスばね	1
19		112-17114	ROLLER SHAFT	上下棒コロ軸	1
20		112-17213	ROLLER	上下棒コロ	2

10. OIL LUBRICATION COMPONENTS

給油関係

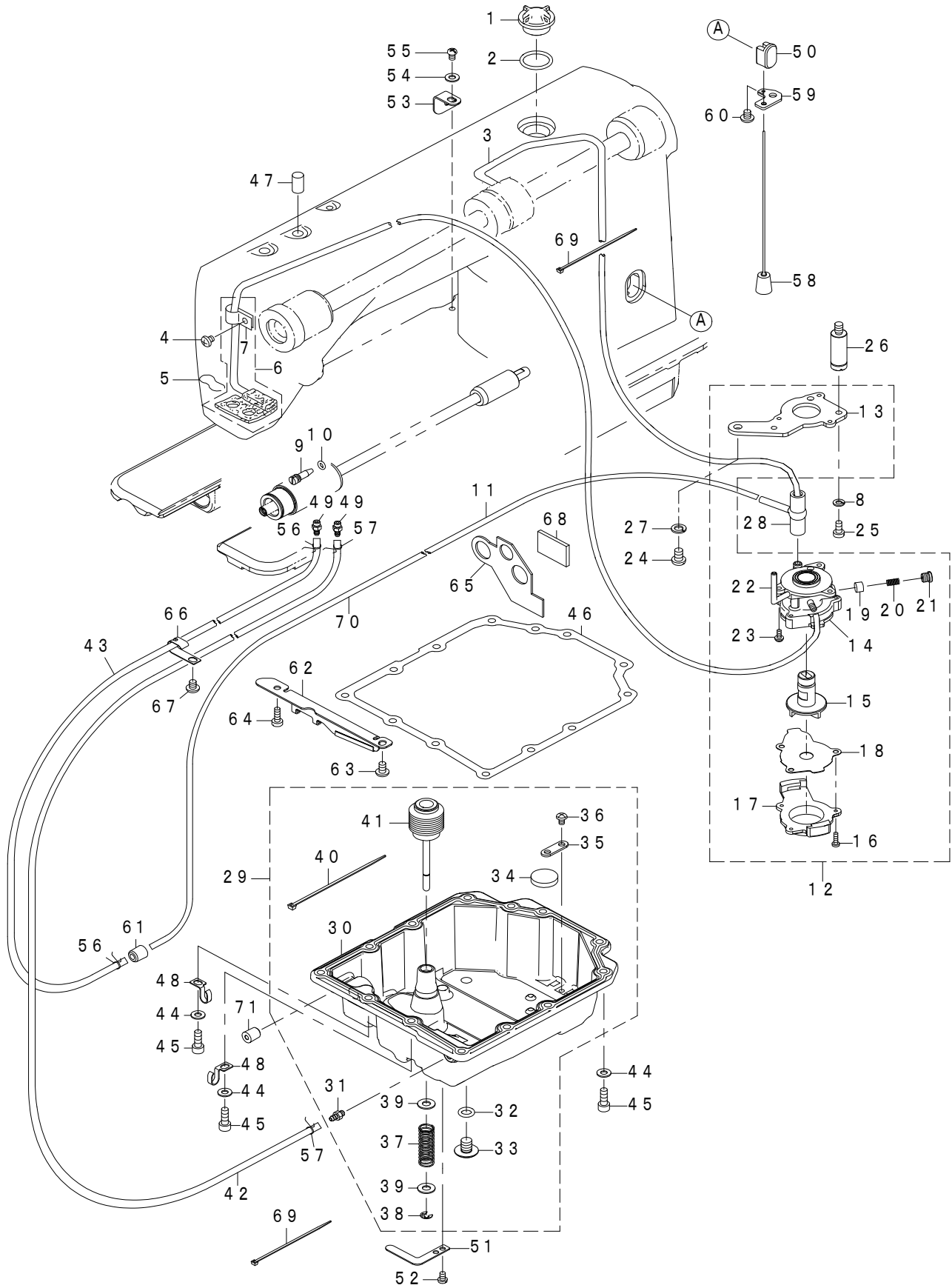

REF.NO	NOTE	PART NO	DESCRIPTION	品名	Qty
1		229-24708	OIL SIGHT WINDOW	油窓	1
2		RO-1952401-00	RUBBER RING	Oリング	1
3		401-84543	MAIN_SHAFT_OIL_TUBE	上軸給油パイプ	1
4		SS-4120615-SP	SCREW 3/16-28 L=6	なべねじ 3/16-28 L=6	1
5		229-25101	OIL FELT PRESSER	還流フェルト押え	1
6		229-24153	OIL RETURN TUBE ASM.	還流パイプ(組)	1
7		229-24302	HOLDER	還流パイプ押え	(1)
8		WS-0451040-KP	SPRING WASHER 4.5X8.5X1	ばね座金 4.5X8.5X1	1
9		400-37502	OIL ADJUSTING SCREW	油量調節ねじ	1
10		RO-0371801-00	RUBBER RING	Oリング	1
11		401-84575	HOOK_OIL_PIPE	釜給油パイプ	1
12		229-23056	LUBRICATING OIL PUMP ASM.	給油ポンプ体(組)	1
13		229-23312	OIL PUMP INSTALLING BASE	ポンプ体取付板	(1)
14		229-23015	OIL PUMP	ポンプ体	(1)
15		229-23700	OIL PUMP IMPELLER	インペラー	(1)
16		SE-4301041-SR	SCREW D=3 L=10	タップタイトねじ D=3 L=10	(1)
17		229-23205	LUBRICATING OIL PUMP COVER	ポンプ体蓋	(1)
18		229-23809	OIL PUMP IMPELLER COVER	ポンプ体受板	(1)
19		229-23403	PLUNGER	プランジャー	(1)
20		229-23601	PLUNGER SPRING	プランジャーばね	(1)
21		229-23502	PLUNGER SCREW	プランジャーねじ	(1)
22		229-23908	HOOK DRIVING SHAFT OIL TUBE	下軸給油パイプ	(1)
23		SL-4030851-SF	SCREW M3 L=8	座金付きなべねじ M3 L=8	(3)
24		SS-4150915-SP	SCREW 15/64-28 L=9	なべねじ 15/64-28 L=9	1
25		SS-6111010-TP	SCREW 11/64-40 L=9.5	平ねじ 11/64-40 L=9.5	1
26		229-24005	PUMP BODY STRUT	ポンプ体支柱	1
27		WS-0651310-KP	SPRING WASHER 6.5X11X1.3	ばね座金 6.5X11X1.3	1
28		229-24609	RUBBER JOINT	給油パイプ継ぎ手	1
29		401-84544	OIL_SHIELD_ASSY	オイルシールド(組)	1
30		401-84545	OIL_SHIELD	オイルシールド	(1)
31		SQ-2050453-MZ	CONNECTING SCREW	パイプ連結ねじ	(1)
32		131-70105	RUBBER RING	Oリング	(1)
33		131-71004	DRAIN SCREW	廃油ねじ	(1)
34		B8228-125-000	OIL RESERVOIR MAGNET	磁石	(1)
35		400-24644	MAGNET WASHER	マグネット押え座金	(1)
36		SM-4040655-SP	SCREW M4 L=6	なべ小ねじ M4 L=6	(1)
37		GAK-30005000	SPRING	膝上げ押し棒ばね	(1)
38		RE-0400000-K0	E-RING 4	E形止め輪 4	(1)
39		WP-0621016-SD	WASHER 6.2X13X1	平座金 6.2X13X1	(2)
40		EA-9500B01-00	CABLE BAND	束線バンド	(1)
41		401-84547	KNEE_LIFTER_PUSH_COMP	ゴム付膝上げ押し棒(組)	(1)
42	#01	236-30007	TUBE	チューブ	0.1
43	#01	236-30007	TUBE	チューブ	0.2
44		WP-0501016-SD	WASHER 5X10.5X1	平座金 5X10.5X1	13
45		SM-6051402-TP	SCREW M5X0.8 L=14	六角穴ボルト	13
46	☆	401-84546	OIL_SHIELD_PACKING	オイルシールドパッキン	1
47		110-39203	FELT	天秤支え軸給油穴フェルト	1
48		262-31902	OIL WICK PIPE STOPPER	油芯パイプ止め	2
49		SQ-2050453-MZ	CONNECTING SCREW	パイプ連結ねじ	2
50		400-17215	OIL_SIGHT_WINDOW	油量指示窓	1
51		131-01407	LOOPER COVER PRESSER PLATE	ルーバーカバー支え板	1
52		SM-4040655-SP	SCREW M4 L=6	なべ小ねじ M4 L=6	1
53		400-28281	FEED_ADJUSTING_STOPPER	送り調節体受板	1
54		WP-0501016-SD	WASHER 5X10.5X1	平座金 5X10.5X1	1
55		SS-4110615-SP	SCREW 11/64-40 L=6	なべ小ねじ 11/64-40 L=6	1
56		236-29306	PIPE STOPPER A	パイプ止めA	2
57		236-29306	PIPE STOPPER A	パイプ止めA	2
58		401-84550	FLOATER_ASM	浮き子(組)	1
59		401-84552	FLOATER_GUIDE	浮き子ガイド	1
60		SS-4120615-SP	SCREW 3/16-28 L=6	なべねじ 3/16-28 L=6	1
61		401-84553	PLUG	ゴム栓	1
62		401-87485	OIL BRACKET ASM	油防板(組)	1
63		SM-4050855-SP	SCREW	なべねじ M5 L=8	1
64		SS-6111210-SP	SCREW 11/64-40 L=12	平ねじ 11/64-40 L=12	1
65		401-87736	FELT	フェルト	1
66		401-36258	CORD HOLDER	コード押え	1
67		SM-4050655-SP	SCREW M5 L=6	なべ小ねじ M5 L=6	1
68		213-45905	FACE ONCE THROUGH FELT	面部還流フェルト	1
69		EA-9500B01-00	CABLE BAND	束線バンド	2
70		236-30007	TUBE	チューブ	0.2
71		401-84553	PLUG	ゴム栓	1
		NOTE(注記)	#01....SELECTIVE PARTS	選択部品	

11. UNDER COVER COMPONENTS

アンダーカバー関係

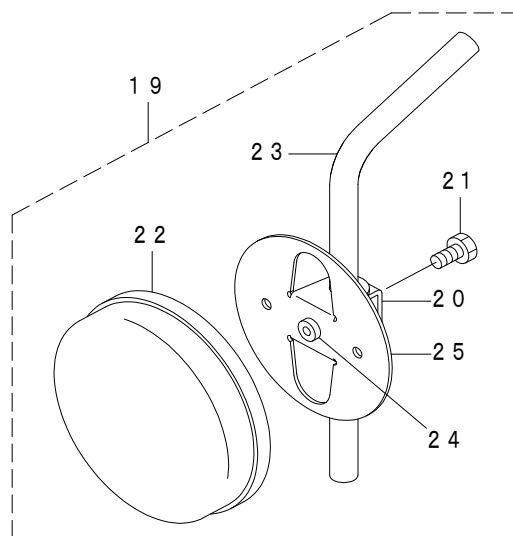
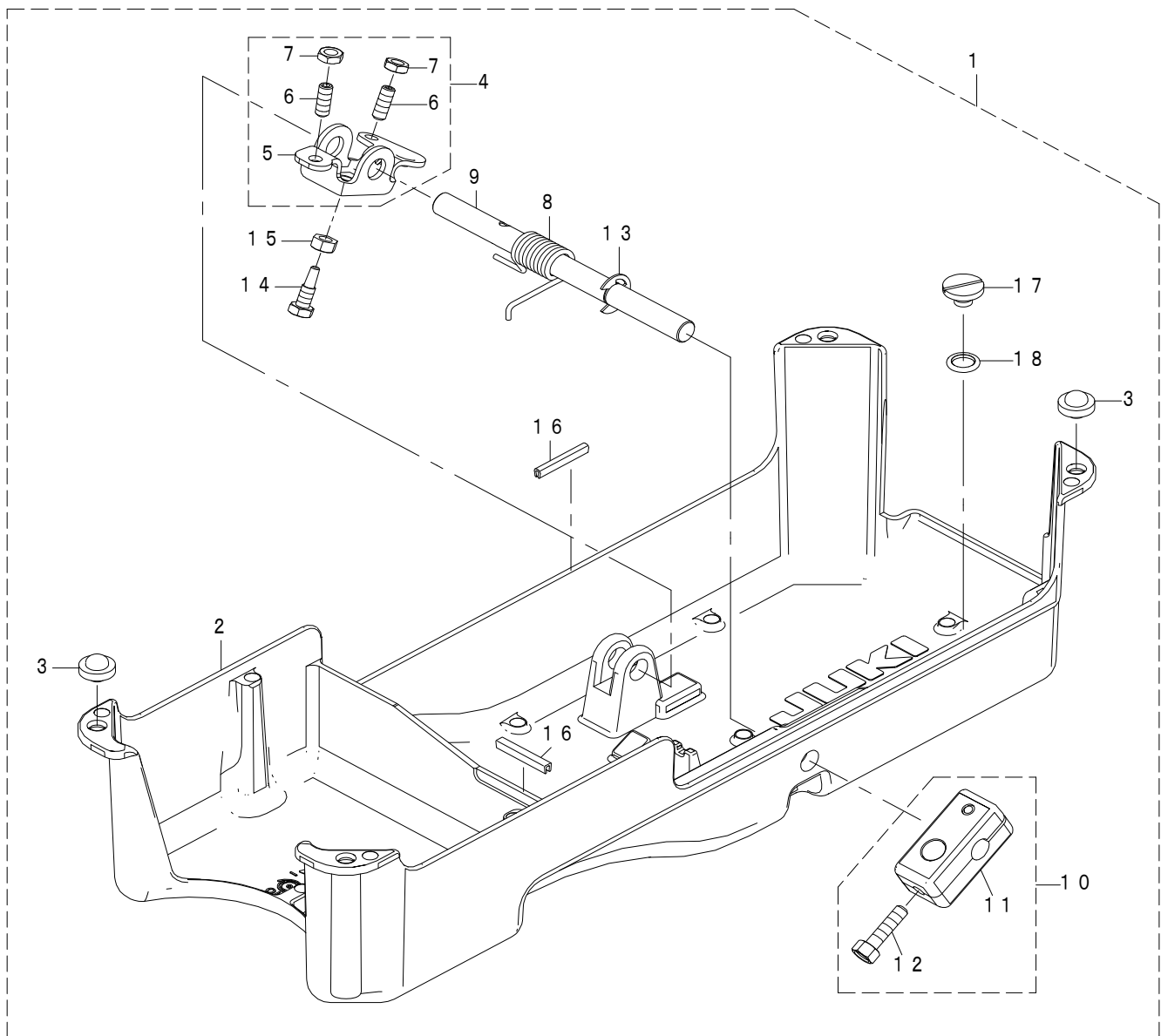

REF.NO	NOTE	PART NO	DESCRIPTION	品名	Qty
1		401-95566	UNDER_COVER_ASSY	アンダーカバー(組)	1
2		401-90445	UNDER_COVER_ADD	アンダーカバー追加工	(1)
3		B1116-210-D00	FRAME SUPPORT RUBBER	頭部支えゴム	(4)
4		401-56725	KNEE LIFTER ROTATION ARM ASM.	膝上げ回転腕 (組)	(1)
5		229-32107	KNEE LIFTER ROTATING ARM	膝上げ回転腕	(1)
6		SM-8061612-TP	SCREW M6X16	止めねじ M6 L=16	(2)
7		NM-6060003-SC	NUT M6	六角ナット M6	(2)
8		401-56726	KNEE LIFTER SPRING	膝上げ回転腕ばね	(1)
9		401-01541	KNEE_PRESS_CROSS_SHAFT	膝当て横軸	(1)
10		229-32453	BRACKET ASM.	膝当て縦軸取付腕 (組)	(1)
11		229-32404	BRACKET	膝当て縦軸取付腕	(1)
12		229-34707	SCREW	膝当て縦軸取付腕締めねじ	(2)
13		RE-1000000-K0	E-RING 10	E形止め輪 10	(1)
14		SM-9061853-SR	SCREW M6 L=17.5	六角ボルト	(1)
15		NM-6060001-SE	NUT M6	六角ナット M6 1種	(1)
16		HX-0066900-0A	GROMMET	グロメット	(2)
17		SS-6700710-SH	SCREW 5/16-24 L=7	平ねじ 5/16-24 L=7	(1)
18		RO-0982401-00	O-RING	Oリング	(1)
19		229-34251	KNEE PAD PLATE ASM.	膝当て板 (組)	1
20		229-34301	KNEE PAD PLATE SUPPORT	膝当て板支え	(1)
21		SM-9061203-SE	SCREW M6 L=12	六角ボルト M6 L=12	(1)
22		229-34509	KNEE PAD PLATE COVER	膝当て板カバー	(1)
23		229-34608	KNEE PAD UPRIGHT SHAFT	膝当て立軸	(1)
24		229-34400	KNEE PAD PLATE RUBBER	膝当て板ゴム	(1)
25		229-34202	KNEE PAD PLATE	膝当て板	(1)

12. PSC UNIT

PSC ユニット

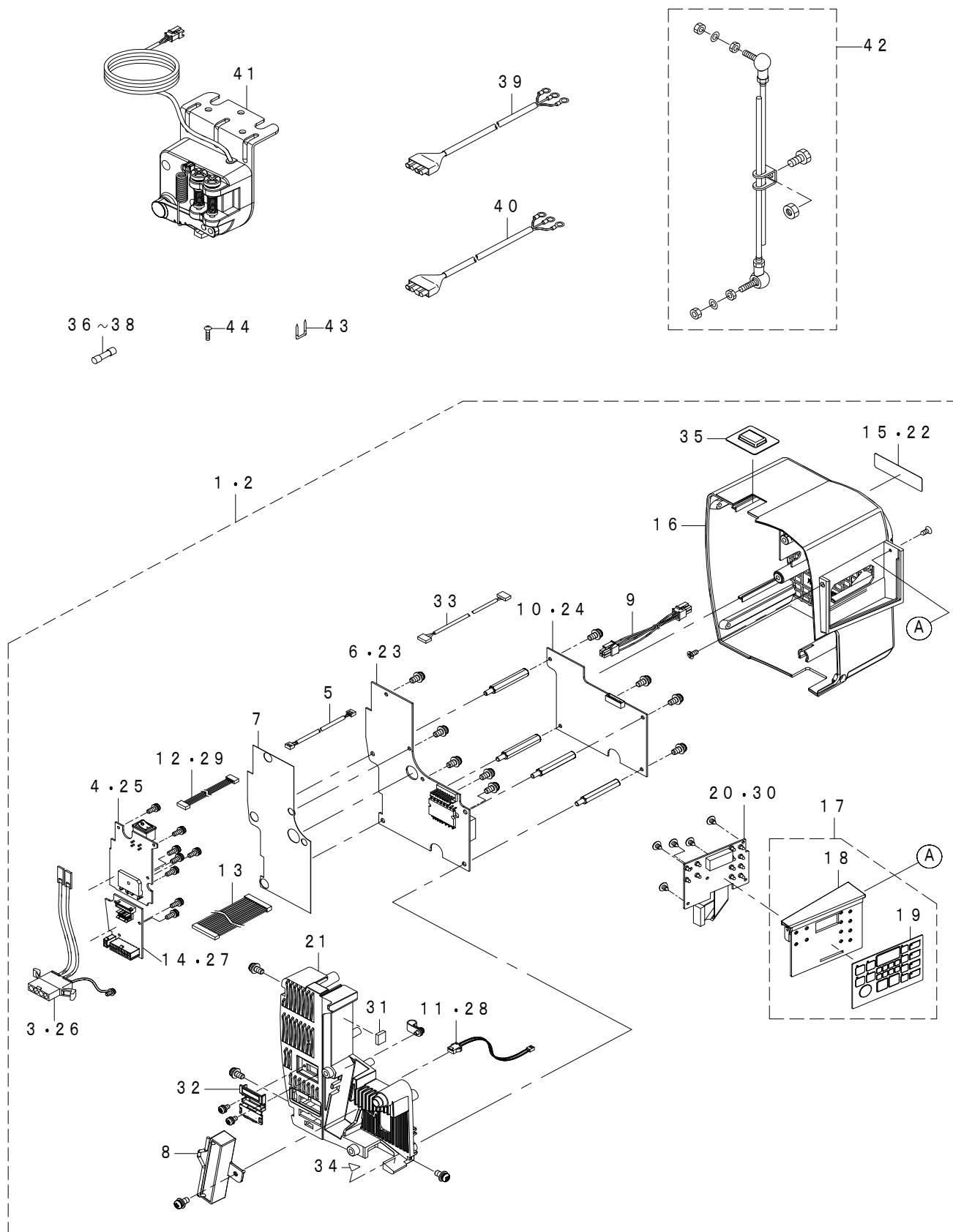

REF.NO	NOTE	PART NO	DESCRIPTION	品名	Qty
1	#01	401-90712	CONTROL BOX SET 1P 220-240V	電装セット	1
2	#02	401-90714	CONTROL_BOX_SET 1P 220-240V_CE	電装セットCE	1
3	#01	401-41200	AC INPUT CORD ASSY	AC入力コード組	(1)
4	#01	401-41201	FLT PCB ASSY	FLT基板組	(1)
5		401-41203	INPUT CHECK CORD ASSY	入力確認コード組	(1)
6	#01	401-41204	PWR PCB ASSY	PWR基板組	(1)
7		401-41205	PWR PCB FILM SHEET	PWR基板保護シート	(1)
8		401-41206	RESISTANCE_A_ASSY	回生抵抗組	(1)
9		401-41207	DC POWER SUPPLY CORD ASSY	DC電源ケーブル組	(1)
10	#01	401-41208	CTL PCB ASSY	CTL基板組	(1)
11	#01	401-41209	PEDAL CORD ASSY	ペダルコード組	(1)
12	#01	401-41210	SOL POWER CORD ASSY	SOL電源ケーブル組	(1)
13		401-41211	SOL SIGNAL CORD ASSY	SOL信号ケーブル組	(1)
14	#01	401-41212	SOL PCB ASSY	SOL基板組	(1)
15	#01	401-56706	RATING LABEL A DRAWING	定格銘板	(1)
16		401-90447	PSC COVER ADD	電装カバー追加加工	(1)
17		401-41214	PANEL COVER ASSY	パネルカバー組	(1)
18		401-41215	PANEL COVER	パネルカバー	(1)
19		401-41216	MEMBRANE SWITCH	メンブレンスイッチ	(1)
20	#01	401-41213	PNL PCB ASSY	PNL基板組	(1)
21		401-90448	FRAME ADD	フレーム追加加工	(1)
22	#02	401-56707	RATING LABEL C DRAWING	定格銘板CE	(1)
23	#02	401-45554	PWR-CE PCB ASSY	PWR-CE基板組	(1)
24	#02	401-45555	CTL-CE PCB ASSY	CTL-CE基板組	(1)
25	#02	401-45553	FLT-CE PCB ASSY	FLT-CE基板組	(1)
26	#02	401-49316	AC INPUT CORD ASSY	AC入力コード組CE	(1)
27	#02	401-45556	SOL-CE PCB ASSY	SOL-CE基板組	(1)
28	#02	401-45557	PEDAL CORD CE ASSY	ペダルコードCE組	(1)
29	* #02	402-04743	SOL POWER CORD CE ASSY	SOL電源ケーブルCE組	(1)
30	#02	401-45921	PNL-CE PCB ASSY	PNL-CE基板組	(1)
31	#02	401-45944	EMI GASKET	EMIガスケット	(1)
32		401-57011	CONNECTOR COVER	コネクタカバー	(1)
33		401-45540	PRT CORD ASSY	PRTコード組	(1)
34		CM-3002000-01	FINGER INJURY CAUTION LABEL (16)	指げが注意シール (16)	(1)
35	#01	401-83785	SWITCH DUSTPROOF COVER ASSY	スイッチ防塵カバー (組)	(1)
36	#01	401-41225	SLO-BLO FUSE	タイムラグヒューズ 1.5A	1
37	#01	401-41226	SLO-BLO FUSE	タイムラグヒューズ 3.15A	1
38	#01	401-41227	SLO-BLO FUSE	タイムラグヒューズ 6.3A	1
39	#02	401-62159	AC POWER CORD ASSY CE	AC電源コード組 (CE)	1
40	#02	401-41220	AC POWER CORD ASSY	電源入力線組	1
41		401-41219	PEDAL_SENSOR_A_ASSY	ペダルセンサ組	1
42		400-42134	CONNECTING_ROD_ASSY	連結棒組	1
43	#01	401-41223	CORD STAPLE	ステップル	3
44		401-41224	SCREW	木ねじ	3
		NOTE(注記)	#01.....VARIOUS NOS. FOR DESTINATIONS	仕向地による	
			#02.....FOR CE	CE用	

13. THREAD STAND COMPONENTS

糸立装置関係

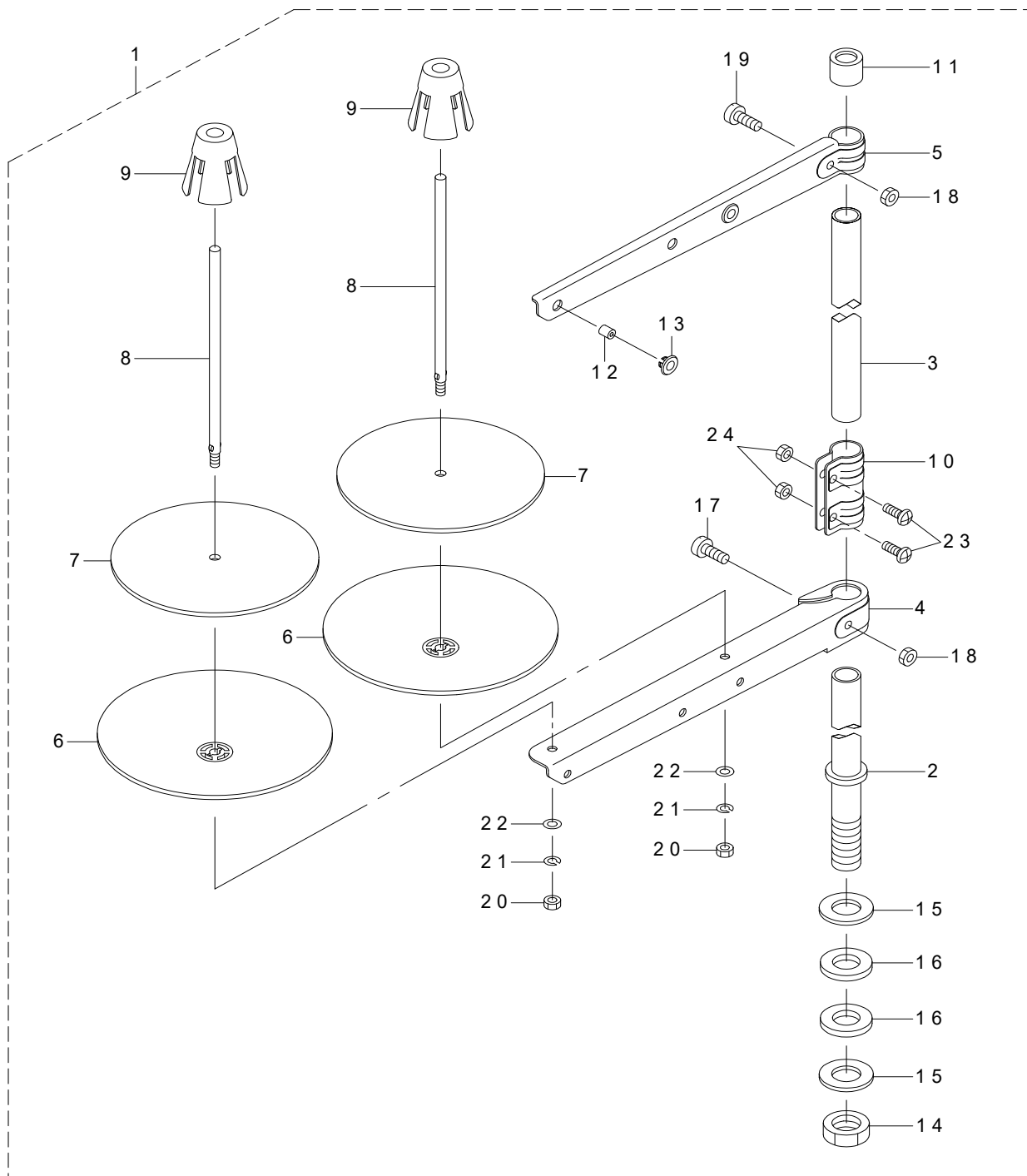

REF.NO	NOTE	PART NO	DESCRIPTION	品名	Qty
1		400-96354	THREAD STAND ASM.	糸立装置 (組)	1
2		400-85784	SPOOL REST ROD LOWER	糸立棒 (下)	(1)
3		400-85785	SPOOL REST ROD UPPER	糸立棒 (上)	(1)
4		400-85786	SPOOL REST ARM LOWER	糸立腕 (下)	(1)
5		400-85787	SPOOL REST ARM UPPER	糸立腕 (上)	(1)
6		400-85788	SPOOL REST	糸巻受皿	(2)
7		400-85789	SPOOL REST CUSHION	糸巻受皿クッション	(2)
8		400-85790	SPOOL PIN	糸巻受棒	(2)
9		400-85791	SPOOL RETAINER	糸巻振れ止め	(2)
10		400-85792	SPOOL REST ROD JOINT	糸立棒継手	(1)
11		400-85793	SPOOL REST ROD RUBBER CAP	糸立棒保護キャップ	(1)
12		400-85794	THREAD GUIDE	糸道	(2)
13		400-85795	THREAD GUIDE BUSHING	糸道ブッシュ	(2)
14		400-96325	SPOOL REST ROD NUT	糸立棒止ナット	(1)
15		WP-1612616-SE	WASHER 16X30X2.6	平座金	(2)
16		400-85796	SPOOL REST ROD RUBBER CUSHION	糸立棒防振ゴム	(2)
17		400-96326	SPOOL REST ARM LOWER SCREW	糸立腕 (下) 止めねじ	(1)
18		NM-6050001-SE	NUT M5	六角ナット M5	(2)
19		400-96327	SPOOL REST ARM UPPER SCREW	糸立腕 (上) 止めねじ	(1)
20		NM-6050001-SE	NUT M5	六角ナット M5	(2)
21		WS-0510002-KN	SPRING WASHER M5	ばね座金 M5	(2)
22		WP-0531001-SC	WASHER M5	平座金みがき丸 M5	(2)
23		SM-4051405-SE	SCREW M5 L=14	なべ小ねじ M5 L=14	(2)
24		NM-6050001-SE	NUT M5	六角ナット M5	(2)

14. ACCESSORIE PARTS COMPONENTS

付属品関係

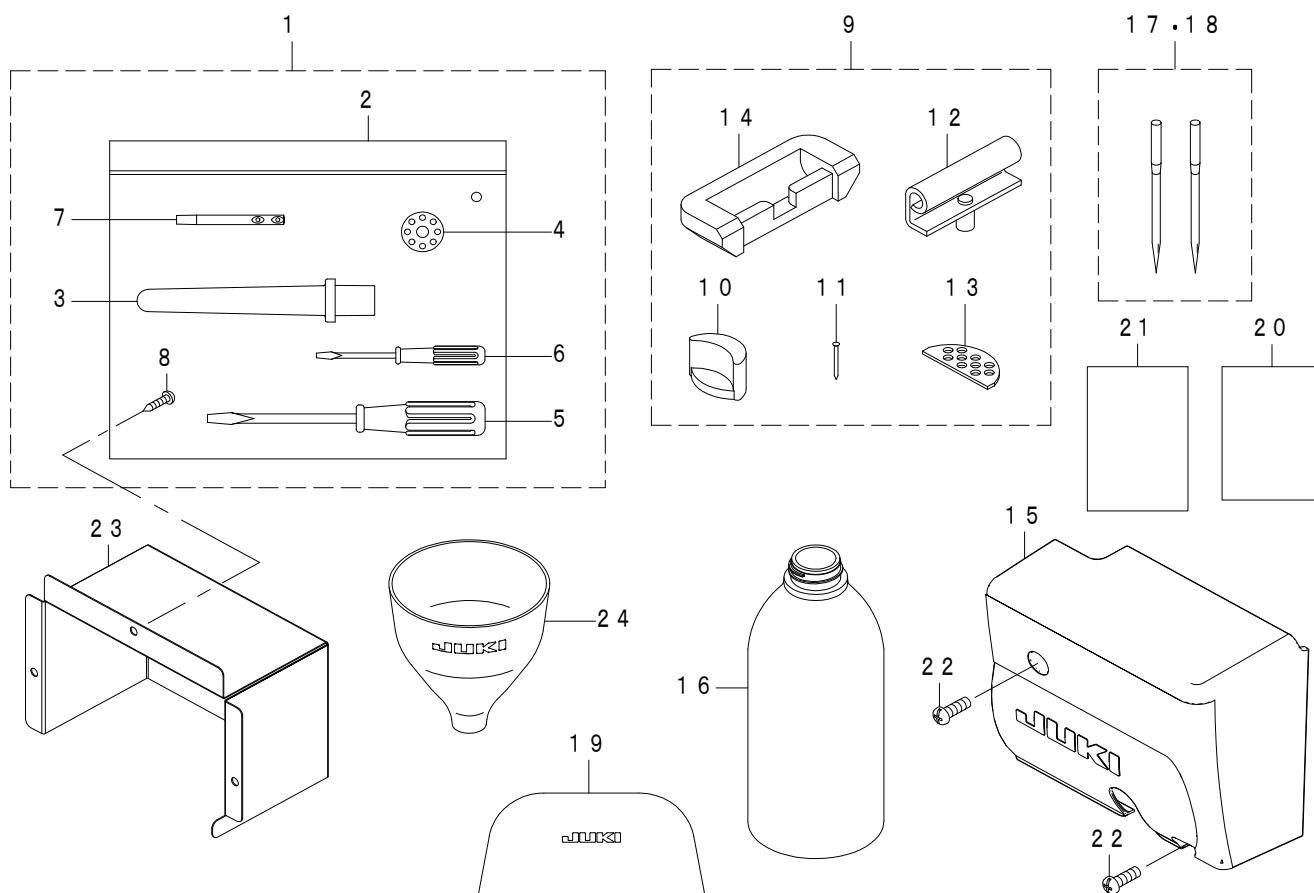

REF.NO	NOTE	PART NO	DESCRIPTION	品名	Qty	
1		401-95573	ACCESSORIE BAG ASSY	付属品バッグ組	1	
2		229-32800	ACCESSORIE BAG	付属品バッグ	(1)	
3		401-90076	FRAME SUPPORT BAR	頭部支え棒	(1)	
4	☆	229-32909	BOBBIN	ボビン	(1)	
5		229-33105	SCREW DRIVER MIDDLE	ドライバー (中)	(1)	
6		229-33204	SCREW DRIVER SMALL	ドライバー (小)	(1)	
7		229-58300	NEEDLE THREAD GUIDE PIN	糸案内棒	(1)	
8		SK-3271301-SE	WOOD SCREW D=2.7 L=13	丸木ねじ D=2.7 L=13	(3)	
9		229-58052	RUBBER HINGE ASM.	ラバーヒンジ (組)	1	
10		229-58003	FRAME BUBBER CUSHION	頭部支えゴム座	(2)	
11		229-26208	NAIL	ゴムヒンジ座打ち釘	(8)	
12		229-26356	HINGE COMPL.	ヒンジ結合	(2)	
13		229-26505	WASHER	頭部クッション座	(2)	
14		229-26000	RUBBER CUSHION	ゴムヒンジ座	(2)	
15		401-87727	REVERSF FEED SOLENOID COVER	逆送りソレノイドカバー	1	
16	☆	#01	MML-007600CA	JUKI MACHINE OIL 7	JUKI マシンオイル 7	1
17	☆	#01	MDB-100B1402	NEEDLE DBX1#14-2	針 DBX1#14-2	1
18	☆	#01	MC-2005009-02	NEEDLE 134 #90-2	針 134 #90-2	1
19		401-35803	HEAD COVER	頭部カバー	1	
20	#01	CM-6001002-01	WEEE INFORMATION SHEET	WEEE インフォメーションシート	1	
21		401-86378	SAFETY_INSTRUCTION_MANUAL(EG)	安全注意書 (DDL-900B) 英語	1	
22		SS-4121415-SP	SCREW 3/16-28 L=14	なべねじ 3/16-28 L=14	2	
23		401-90443	CONDENSE COVER	コンデンスカバー	1	
24		131-60601	FUNNEL	漏斗	1	

NOTE(注記)

#01...ACCORDING TO MANUFACTURING BASE 製造拠点による

15. EXCLUSIVE PARTS FOR H

H 専用部品

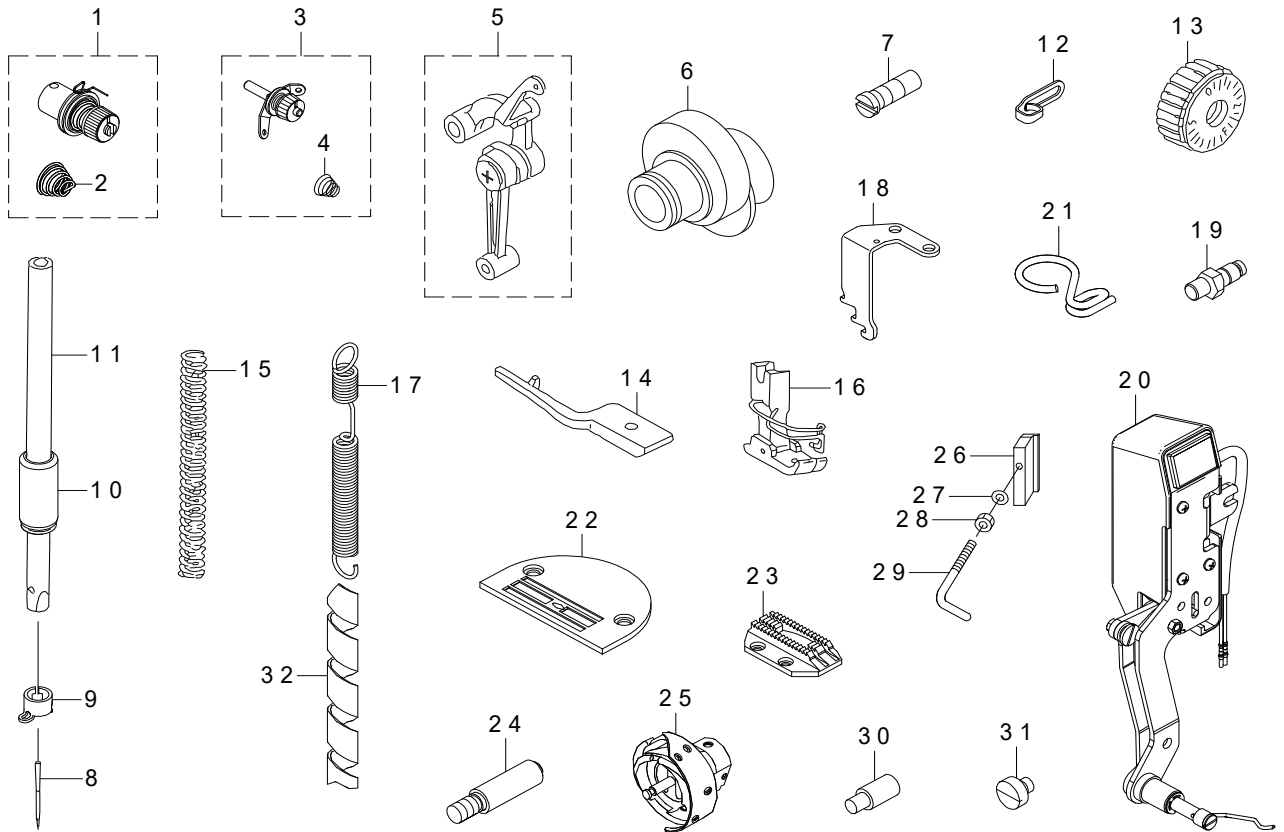

REF.NO	NOTE	PART NO	DESCRIPTION	品名	Qty
1		229-62054	THREAD TENSION ASM.	糸調子 (組)	1
2		229-62005	THREAD TENSION SPRING	糸調子ばね	(1)
3		229-63458	THREAD TENSION ASM	第一糸調子 (組)	1
4		229-63409	THREAD TENSION SPRING	第一糸調子ばね	(1)
5		401-03560	LINK THREAD TAKE-UP LEVER ASM.	リンク天秤 (組)	1
6		229-62351	FEED DRIVE ECCENTRIC CAM ASM.	送り偏心カム (組)	1
7		B1213-552-000-A	OIL ADJUSTING PIN	クランク油量調節ピン	1
8		MDB-100B2100	NEEDLE DBX1 #21	針 DBX1 #21	1
9		B1418-415-H00	NEEDLE BAR THREAD GUIDE	針棒糸掛け	1
10		229-70313	NEEDLE BAR BUSHING LOWER	針棒下メタル	1
11		229-70206	NEEDLE BAR	針棒	1
12		110-91006	ARM THREAD GUIDE (HA)	アーム糸案内 (HA)	1
13		401-01726	FEED_DIAL	送りダイヤル	1
14		401-74353	INNER_HOOK HOLDER_H	中釜押えH	1
15		B1505-552-000-A	PRESSER SPRING	押え調節ばね	1
16		D1524-555-EBL	PRESSER FOOT ASM.	自由押え (組) (針ガード付き)	1
17		401-90609	ADJUSTING_LINK_SPRING	送り調節ばね	1
18		401-84565	FEED_SPRING_HOOK	送りばね掛け	1
19		229-71204	FEED REGULATOR BASE PIN	送り調節台ピン	1
20		401-41076	WIPER_ASSY_H	ワイパー組H	1
21		400-23223	NEEDLE BAR THREAD GUIDE	針棒糸案内	1
22		114-00801	THROAT PLATE J	針板 J	1
23		114-03003	FEED J	送り J	1
24		401-15888	LEVER_STOPPER_ASSY	レバーストッパー (組)	1
25		110-92251	HOOK ASM.	金給油 (組)	1
26		114-03805	THREAD GUIDE C FITTING PLATE	糸案内C取付板	1
27		WP-0371016-SD	WASHER 3.7X8X1	平座金 3.7X8X1	1
28		NS-6090310-SP	NUT 9/64-40	六角ナット 9/64-40	1
29		229-72608	ARM THREAD GUIDE C	アーム糸案内C	1
30		400-10395	ADJUSTING LINK FULCRUM SHAFT B	調節リンク支点軸	1
31		SS-6080320-SP	SCREW 1/8-44 L=2.5	平ねじ 1/8-44 L=2.5	1
32		HX-0018900-00	SPIRAL TUBE	スパイラルチューブ	1

16. EXCLUSIVE PARTS TYPE NB

NB 仕様専用部品

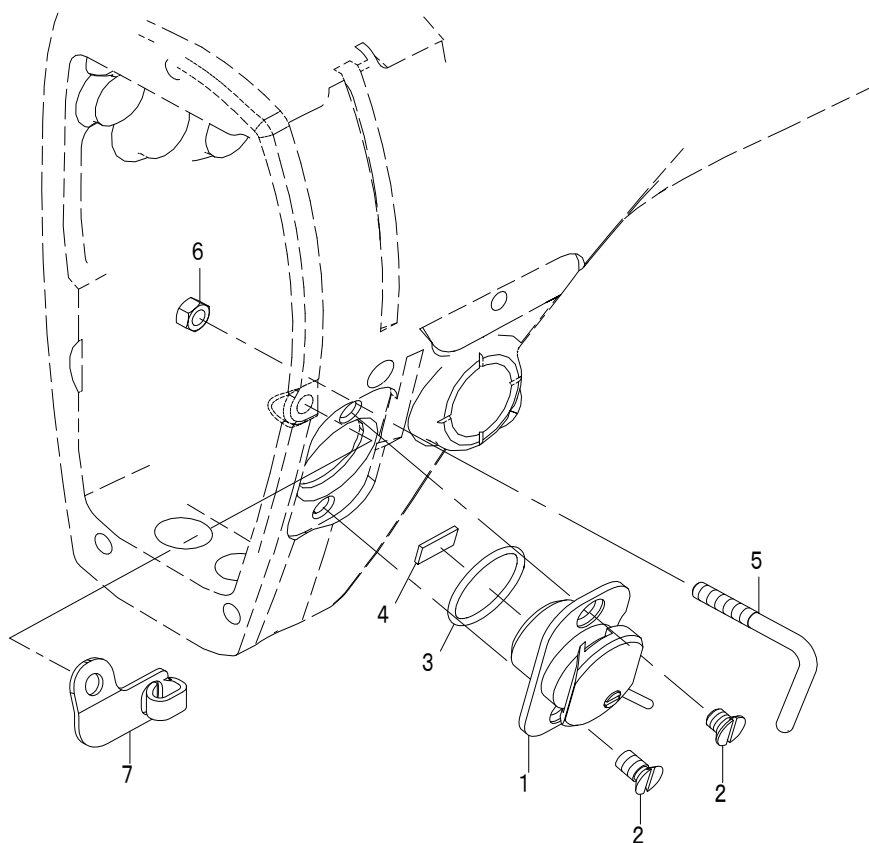

REF.NO	NOTE	PART NO	DESCRIPTION	品名	Qty
1		401-90699	THREAD_NIPPER_SET	糸押えセット	1
2		SS-1110640-TP	SCREW 11/64-40 L=5.5	皿ねじ 11/64-40 L=5.5	2
3		G1164-870-000	SUCTION O RING	サクシヨンOリング	1
4		134-03605	RUBBER_PLATE	ラバープレート	1
5		401-87738	ARM THREAD GUIDE	アーム糸案内	1
6		NS-6090310-SP	NUT 9/64-40	六角ナット 9/64-40	1
7		401-87311	ARM THREAD GUIDE B	アーム糸案内B	1

NUMERICAL INDEX OF PARTS

索引

PART NO 品番	PAGE 頁	REF NO	PART NO 品番	PAGE 頁	REF NO	PART NO 品番	PAGE 頁	REF NO	PART NO 品番	PAGE 頁	REF NO
BT-1000651-EB	10	53	RE-0600000-K0	14	13	SS-4151215-SP	14	15	WP-0720316-RZ	16	10
B1109-552-000	2	44	RE-1000000-K0	20	13	SS-6060210-SP	2	54	WP-0820816-SD	14	32
B1116-210-D00	14	40	RO-0291801-00	6	35	SS-6080320-SP	26	31	WP-0841600-SD	16	15
B1116-210-D00	20	3	RO-0360802-00	8	47	SS-6080410-SP	2	3	WP-1612616-SE	24	15
B1213-552-000-A	26	7	RO-0360802-00	8	48	SS-6090620-TP	12	14	WS-0451040-KP	18	8
B1215-552-000	6	26	RO-0371801-00	10	3	SS-6090620-TP	12	30	WS-0510002-KN	24	21
B1418-415-H00	26	9	RO-0371801-00	18	10	SS-6090620-TP	12	41	WS-0651310-KP	18	27
B1505-552-000-A	26	15	RO-0442401-00	6	43	SS-6090670-TP	8	5	WT-0530002-KS	2	56
B1521-555-000	10	2	RO-0781901-00	14	23	SS-6090670-TP	12	3			
B1524-012-0BA	10	9	RO-0922702-00	12	74	SS-6090910-SP	10	38	101-09700	16	4
B1613-012-I00	12	33	RO-0982401-00	20	18	SS-6110420-TP	8	30	110-02904	6	3
B3510-205-000	15	28	RO-1331701-00	12	81	SS-6110610-TP	2	48	110-09800	12	23
B8228-125-000	18	34	RO-1952401-00	18	2	SS-6111010-TP	18	25	110-15906	8	37
B9117-552-A00	8	45	RO-5552002-00	15	21	SS-6111210-SP	8	33	110-37405	12	22
						SS-6111210-SP	18	64	110-38650	8	34
CM-3002000-01	2	12	SD-0600406-TP	14	34	SS-6121610-SP	2	44	110-38759	8	24
CM-3002000-01	2	61	SD-0720331-SP	10	12	SS-6121840-SP	12	17	110-39203	18	47
CM-3002000-01	22	34	SD-0850751-SP	14	16	SS-6121860-SP	12	5	110-79506	8	40
CM-3003000-01	16	11	SD-1000801-SH	12	47	SS-6151220-SP	12	29	110-91006	26	12
CM-6001002-01	25	20	SE-4301041-SR	18	16	SS-6661110-SP	6	17	110-92251	26	25
CQ-2020000-00	10	27	SK-3271301-SE	25	8	SS-6700710-SH	20	17	112-17114	15	13
CQ-2200000-00	8	28	SL-4030851-SF	18	23	SS-7080510-TP	8	9	112-17114	16	19
			SL-4052091-SC	15	23	SS-7090610-SP	14	6	112-17213	15	14
D1524-555-EBL	26	16	SL-6051492-TN	6	39	SS-7091110-TP	10	6	112-17213	16	20
D3164-555-B00	10	15	SL-6052592-TN	6	38	SS-7110720-SP	2	59	112-43763	10	45
D6056-555-B00	16	16	SM-0050801-SC	4	31	SS-7110740-TP	12	53	112-44019	10	50
D7133-555-B00	4	29	SM-0050801-SC	4	35	SS-7110740-TP	15	7	112-44209	10	48
			SM-4040655-SP	18	36	SS-7111120-SP	12	59	114-00801	26	22
EA-9500B01-00	18	40	SM-4040655-SP	18	52	SS-7120770-SH	12	6	114-03003	26	23
EA-9500B01-00	18	69	SM-4040885-SP	10	55	SS-7121410-TP	12	56	114-03805	26	26
			SM-4050655-SP	18	67	SS-7121610-SP	12	46	114-19504	14	41
GAK-30005000	18	37	SM-4050855-SP	10	17	SS-7620750-SP	12	77	114-19603	14	42
G1164-870-000	27	3	SM-4050855-SP	14	39	SS-7681650-TP	6	44	114-19702	14	43
			SM-4050855-SP	18	63	SS-8090670-SP	2	41	114-19801	14	44
HK-0346101-40	14	17	SM-4051405-SE	24	23	SS-8110422-TP	14	25	114-19900	14	45
HK-0346101-40	15	9	SM-5040655-SN	4	20	SS-8150710-TP	2	42	114-20601	14	52
HK-0346400-0B	15	8	SM-6051002-TP	15	20	SS-8151150-TP	6	1	114-33802	10	52
HX-0006500-0A	10	54	SM-6051002-TP	16	17	SS-8660610-TP	6	24	131-01407	18	51
HX-0018900-00	26	32	SM-6051402-TP	18	45	SS-8660610-TP	6	31	131-60601	25	24
HX-0066900-0A	20	16	SM-6051602-TP	14	11	SS-8660610-TP	6	42	131-70105	18	32
			SM-6051602-TP	15	15	SS-8660610-TP	12	50	131-71004	18	33
MC-2005009-02	25	18	SM-6062502-TP	16	6	SS-8660610-TP	12	63	134-03605	27	4
MDB-100B1400	8	11	SM-8040802-TP	4	21	SS-8660612-TP	14	27	138-87005	12	17
MDB-100B1402	25	17	SM-8050502-TP	4	22	SS-8660810-TP	8	15			
MDB-100B2100	26	8	SM-80506A2-TP	14	12	SS-8660810-TP	8	17	213-45905	18	68
MML-007600CA	25	16	SM-80608A2-TP	6	33	SS-8660810-TP	8	20	225-38805	6	30
			SM-8061612-TP	20	6	SS-8660810-TP	8	22	228-87905	12	71
NM-6040001-SC	14	7	SM-9061203-SE	20	21	SS-8660810-TP	10	37	228-88507	12	61
NM-6050001-SE	24	18	SM-9061853-SR	20	14	SS-8661012-TP	14	3	228-90206	8	43
NM-6050001-SE	24	20	SQ-2050453-MZ	15	25	SS-8661012-TP	16	12	228-90305	8	44
NM-6050001-SE	24	24	SQ-2050453-MZ	18	31	SS-8681650-TP	6	41	228-90404	8	42
NM-6060001-SE	20	15	SQ-2050453-MZ	18	49				228-96252	8	46
NM-6060003-SC	20	7	SS-1110640-TP	27	2	TA-0400301-M0	15	24	229-00401	2	10
NS-6090310-SP	26	28	SS-2110915-SP	2	46	TA-0850604-R0	2	5	229-00609	2	28
NS-6090310-SP	27	6	SS-2110920-TP	2	45	TA-0850604-R0	8	1	229-01003	2	55
NS-6120630-SP	4	27	SS-4080620-TP	12	34	TA-0950806-R0	12	65	229-01201	2	52
NS-6620310-SP	10	21	SS-4090615-SP	6	19	TA-1030402-R0	2	69	229-01250	2	51
NS-6680410-SP	12	42	SS-4110515-SP	10	16	TA-1250406-R0	2	49	229-01300	2	53
			SS-4110515-SP	12	37	TA-1250705-R0	2	6	229-01805	2	14
RC-0150001-KP	12	32	SS-4110615-SP	18	55	TA-2000502-R0	2	16	229-03207	6	25
RC-0150001-KP	12	54	SS-4120615-SP	2	15	TA-2100904-R0	2	9	229-03306	6	27
RC-0260415-K0	15	12	SS-4120615-SP	2	27	TA-2101002-R0	2	19	229-03900	6	14
RC-0260415-K0	16	13	SS-4120615-SP	2	29	TA-2351004-R0	12	78	229-05004	8	23
RC-0560711-KP	4	18	SS-4120615-SP	2	62				229-05103	8	25
RC-0650811-KP	16	8	SS-4120615-SP	2	71	WP-0371016-SD	14	5	229-05202	8	26
RC-1850001-KP	6	22	SS-4120615-SP	10	19	WP-0371016-SD	26	27	229-06101	8	2
RC-2651218-KP	14	53	SS-4120615-SP	15	10	WP-0450826-SC	4	23	229-06200	8	8
RE-0400000-K0	4	19	SS-4120615-SP	18	4	WP-0480856-SP	12	57	229-06309	8	10
RE-0400000-K0	18	38	SS-4120615-SP	18	60	WP-0482086-SD	10	46	229-06457	8	4
RE-0500000-K0	10	8	SS-4120925-SP	2	8	WP-0501016-SD	18	44	229-06606	6	8
RE-0500000-K0	10	22	SS-4120925-SP	2	50	WP-0501016-SD	18	54	229-07307	10	36
RE-0500000-K0	10	41	SS-4120925-SP	8	39	WP-0531001-SC	24	22	229-07406	10	33
RE-0500000-K0	10	43	SS-4121415-SP	25	22	WP-0611626-SP	12	70	229-07505	10	32
RE-0500000-K0	12	18	SS-4150915-SP	18	24	WP-0621016-SD	18	30	229-07554	10	30
RE-0500000-K0	12	21	SS-4151215-SP	2	64	WP-0641600-SC	16	7	229-07604	10	31

NUMERICAL INDEX OF PARTS

索引

PART NO 品番	PAGE 頁	REF NO	PART NO 品番	PAGE 頁	REF NO	PART NO 品番	PAGE 頁	REF NO	PART NO 品番	PAGE 頁	REF NO
229-07703	10	25	229-24153	18	6	262-61206	4	10	401-13241	4	34
229-07802	10	1	229-24302	18	7	262-61305	4	11	401-15888	26	24
229-08008	10	42	229-24609	18	28	262-61503	4	12	401-19475	4	24
229-08156	10	40	229-24708	18	1	262-61602	4	13	401-25485	12	31
229-08305	10	44	229-25101	18	5	262-61701	4	14	401-26308	2	60
229-08354	10	39	229-26000	25	14				401-26849	8	49
229-08552	10	4	229-26208	25	11	400-10395	12	84	401-27153	14	2
229-08701	10	7	229-26356	25	12	400-10395	26	30	401-27164	14	21
229-08800	10	14	229-26505	25	13	400-10805	8	51	401-27168	14	26
229-08909	10	11	229-32107	20	5	400-11144	4	15	401-27180	14	28
229-09006	10	13	229-32404	20	11	400-12126	2	2	401-27182	14	30
229-10004	6	18	229-32453	20	10	400-12129	2	11	401-27183	14	31
229-10053	6	16	229-32800	25	2	400-17215	18	50	401-27190	14	20
229-10103	6	13	229-32909	8	18	400-17805	10	35	401-27192	8	31
229-10202	12	15	229-32909	25	4	400-21933	4	17	401-33950	12	80
229-10251	12	11	229-33105	25	5	400-22407	2	68	401-35803	25	19
229-10459	12	27	229-33204	25	6	400-23223	26	21	401-36014	8	29
229-10806	12	28	229-34202	20	25	400-24644	18	35	401-36258	2	67
229-10905	12	24	229-34251	20	19	400-28281	18	53	401-36258	18	66
229-11002	12	40	229-34301	20	20	400-29963	12	66	401-37504	6	23
229-11101	12	13	229-34400	20	24	400-29963	12	79	401-37504	12	49
229-11408	12	1	229-34509	20	22	400-37008	4	32	401-37504	12	62
229-11507	12	2	229-34608	20	23	400-37502	18	9	401-39216	6	21
229-11606	12	4	229-34707	20	12	400-42134	22	42	401-39771	15	2
229-11804	12	7	229-39508	8	3	400-50314	10	10	401-40080	2	66
229-12000	12	9	229-39607	8	41	400-60989	10	5	401-40191	15	3
229-12109	12	8	229-40506	12	10	400-85784	24	2	401-40306	15	4
229-12257	12	19	229-40654	12	55	400-85785	24	3	401-40419	6	37
229-12505	12	20	229-40753	12	35	400-85786	24	4	401-41076	26	20
229-13008	12	75	229-41306	12	36	400-85787	24	5	401-41200	22	3
229-13701	12	38	229-45307	2	40	400-85788	24	6	401-41201	22	4
229-13800	12	16	229-45356	2	32	400-85789	24	7	401-41203	22	5
229-13859	12	12	229-45414	2	22	400-85790	24	8	401-41204	22	6
229-15003	12	73	229-45604	2	23	400-85791	24	9	401-41205	22	7
229-15359	12	58	229-45703	2	26	400-85792	24	10	401-41206	22	8
229-16308	8	27	229-45703	4	30	400-85793	24	11	401-41207	22	9
229-16506	8	38	229-45802	2	24	400-85794	24	12	401-41208	22	10
229-16555	8	36	229-52501	2	18	400-85795	24	13	401-41209	22	11
229-18064	6	5	229-53400	12	82	400-85796	24	16	401-41210	22	12
229-18072	6	4	229-58003	25	10	400-86744	8	50	401-41211	22	13
229-18106	6	7	229-58052	25	9	400-89548	12	25	401-41212	22	14
229-18304	6	6	229-58300	2	7	400-90002	8	14	401-41213	22	20
229-18403	6	9	229-58300	25	7	400-90003	8	16	401-41214	22	17
229-18502	6	10	229-62005	26	2	400-90004	8	19	401-41215	22	18
229-18601	6	11	229-62054	26	1	400-90005	8	21	401-41216	22	19
229-18700	6	12	229-62351	26	6	400-90058	8	6	401-41219	22	41
229-19203	6	29	229-63409	2	25	400-90529	16	9	401-41220	22	40
229-19559	6	2	229-63409	26	4	400-93417	12	26	401-41223	22	43
229-20102	10	29	229-63458	2	21	400-96325	24	14	401-41224	22	44
229-20201	10	23	229-63458	26	3	400-96326	24	17	401-41225	22	36
229-20300	10	26	229-70206	26	11	400-96327	24	19	401-41226	22	37
229-20409	10	24	229-70313	26	10	400-96354	24	1	401-41227	22	38
229-20508	2	30	229-71204	26	19	400-98388	10	34	401-41523	8	7
229-20607	2	47	229-72608	26	29	400-99083	2	58	401-45540	22	33
229-20904	2	43	236-10652	10	49	401-01541	20	9	401-45553	22	25
229-21001	2	31	236-10702	10	51	401-01726	26	13	401-45554	22	23
229-21209	2	38	236-11106	10	47	401-02097	2	1	401-45555	22	24
229-21308	2	33	236-20206	8	12	401-02261	2	13	401-45556	22	27
229-21407	2	34	236-29306	15	27	401-03560	26	5	401-45557	22	28
229-21506	2	37	236-29306	18	56	401-09422	12	45	401-45921	22	30
229-21506	4	28	236-29306	18	57	401-10376	6	45	401-45944	22	31
229-21605	2	39	236-30007	15	26	401-10379	12	43	401-48382	15	1
229-21704	2	35	236-30007	18	42	401-10390	6	40	401-49069	15	5
229-21803	2	36	236-30007	18	43	401-10731	4	25	401-49316	22	26
229-23015	18	14	236-30007	18	70	401-10734	4	26	401-56677	2	4
229-23056	18	12	236-32102	15	6	401-10975	4	16	401-56684	12	39
229-23205	18	17	262-31902	18	48	401-10976	4	1	401-56706	22	15
229-23312	18	13	262-60109	4	2	401-10977	6	15	401-56707	22	22
229-23403	18	19	262-60208	4	3	401-10978	6	20	401-56725	20	4
229-23502	18	21	262-60307	4	4	401-10979	6	28	401-56726	20	8
229-23601	18	20	262-60406	4	5	401-11025	6	36	401-56758	12	64
229-23700	18	15	262-60505	4	6	401-11424	6	32	401-57011	22	32
229-23809	18	18	262-60604	4	7	401-11896	2	70	401-62159	22	39
229-23908	18	22	262-60802	4	8	401-11897	12	52	401-63521	4	33
229-24005	18	26	262-61008	4	9	401-12907	14	18	401-72479	14	10

NUMERICAL INDEX OF PARTS

索引

PART NO 品番	PAGE 頁	REF NO	PART NO 品番	PAGE 頁	REF NO	PART NO 品番	PAGE 頁	REF NO	PART NO 品番	PAGE 頁	REF NO
401-72480	14	35	401-95552	14	48						
401-74351	8	32	401-95566	20	1						
401-74353	26	14	401-95573	25	1						
401-74612	14	46	401-96831	14	38						
401-78658	14	37	401-96832	2	63						
401-82291	2	65	401-96923	14	1						
401-83785	22	35	401-98464	15	17						
401-84531	12	68	402-00018	14	54						
401-84533	12	60	402-00576	6	34						
401-84535	12	69	402-04743	22	29						
401-84536	12	51									
401-84537	12	76									
401-84540	8	13									
401-84541	10	28									
401-84543	18	3									
401-84544	18	29									
401-84545	18	30									
401-84546	18	46									
401-84547	18	41									
401-84550	18	58									
401-84552	18	59									
401-84553	18	61									
401-84553	18	71									
401-84557	14	24									
401-84558	14	19									
401-84560	15	16									
401-84562	15	11									
401-84565	26	18									
401-84575	18	11									
401-86203	14	14									
401-86209	12	67									
401-86378	25	21									
401-86644	12	48									
401-86696	10	18									
401-86847	15	19									
401-87304	15	18									
401-87306	14	29									
401-87307	15	22									
401-87308	10	20									
401-87311	27	7									
401-87485	18	62									
401-87727	25	15									
401-87734	14	22									
401-87736	18	65									
401-87738	27	5									
401-88851	2	57									
401-90076	25	3									
401-90435	16	1									
401-90440	16	2									
401-90443	25	23									
401-90444	16	14									
401-90445	20	2									
401-90446	12	72									
401-90447	22	16									
401-90448	22	21									
401-90450	16	3									
401-90451	16	18									
401-90553	14	4									
401-90555	14	51									
401-90556	14	50									
401-90557	14	33									
401-90558	14	9									
401-90559	14	36									
401-90562	8	35									
401-90609	26	17									
401-90682	12	83									
401-90685	2	20									
401-90699	27	1									
401-90712	22	1									
401-90714	22	2									
401-91470	6	46									
401-94932	14	47									
401-94934	16	5									
401-94939	14	8									
401-95289	14	49									