

***ENGLISH***

**DDL-8100B-7 Series  
INSTRUCTION MANUAL**

# CONTENTS

<b>I. SPECIFICATIONS.....</b>	<b>1</b>
<b>II. SET-UP.....</b>	<b>3</b>
1. Installation .....	3
2. Installing the pedal sensor.....	4
3. Connecting the connector.....	4
4. How to install the power plug .....	5
5. Attaching the connecting rod .....	5
6. Winding the bobbin thread.....	6
7. Adjusting the height of the knee lifter.....	7
8. Installing the thread stand .....	7
9. Lubrication.....	8
10. Adjusting the amount of oil (oil splashes).....	8
11. Attaching the needle .....	10
12. Setting the bobbin into the bobbin case.....	11
13. Adjusting the stitch length.....	11
14. Presser foot pressure .....	11
15. Hand lifter .....	11
16. Adjusting the height of the presser bar .....	12
17. Threading the machine head .....	12
18. Thread tension .....	13
19. Thread take-up spring .....	13
20. Adjusting the thread take-up stroke.....	13
21. Needle-to-hook relationship.....	14
22. Height of the feed dog .....	14
23. Tilt of the feed dog .....	15
24. Adjusting the feed timing .....	15
25. Cunter knife .....	16
26. Pedal pressure and pedal stroke.....	16
27. Adjustment of the pedal .....	17
28. Marker dots on the handwheel .....	17
<b>III. FOR THE OPERATOR.....</b>	<b>18</b>
1. Operating procedure of the sewing machine .....	18
2. Operation panel built in the machine head.....	19
3. Operating procedure of the sewing pattern .....	20
4. Setting of functions .....	22
5. Digital types operation .....	23
6. User Parameter & Technician Parameter.....	23
7. Details of setting of the main functions .....	26
8. Stitch balance of back-tacking for lockstitch machine .....	29
9. Error code list.....	32

## I. SPECIFICATIONS

Supply voltage	Single phase 220V
Frequency	50Hz/60Hz
Operating environment	Temperature : 5 to 35°C Humidity 35 - 85 % or less
Input	210VA
Max. sewing speed	4,000 sti/min
Thread trimming speed	210 sti/min
Stitch length	5 mm
Presser foot lift (by knee lifter)	13 mm
Needle	DB x 1 (#14) #14 to 18
Lubricating oil	JUKI MACHINE OIL #7

# DRAWING OF TABLE

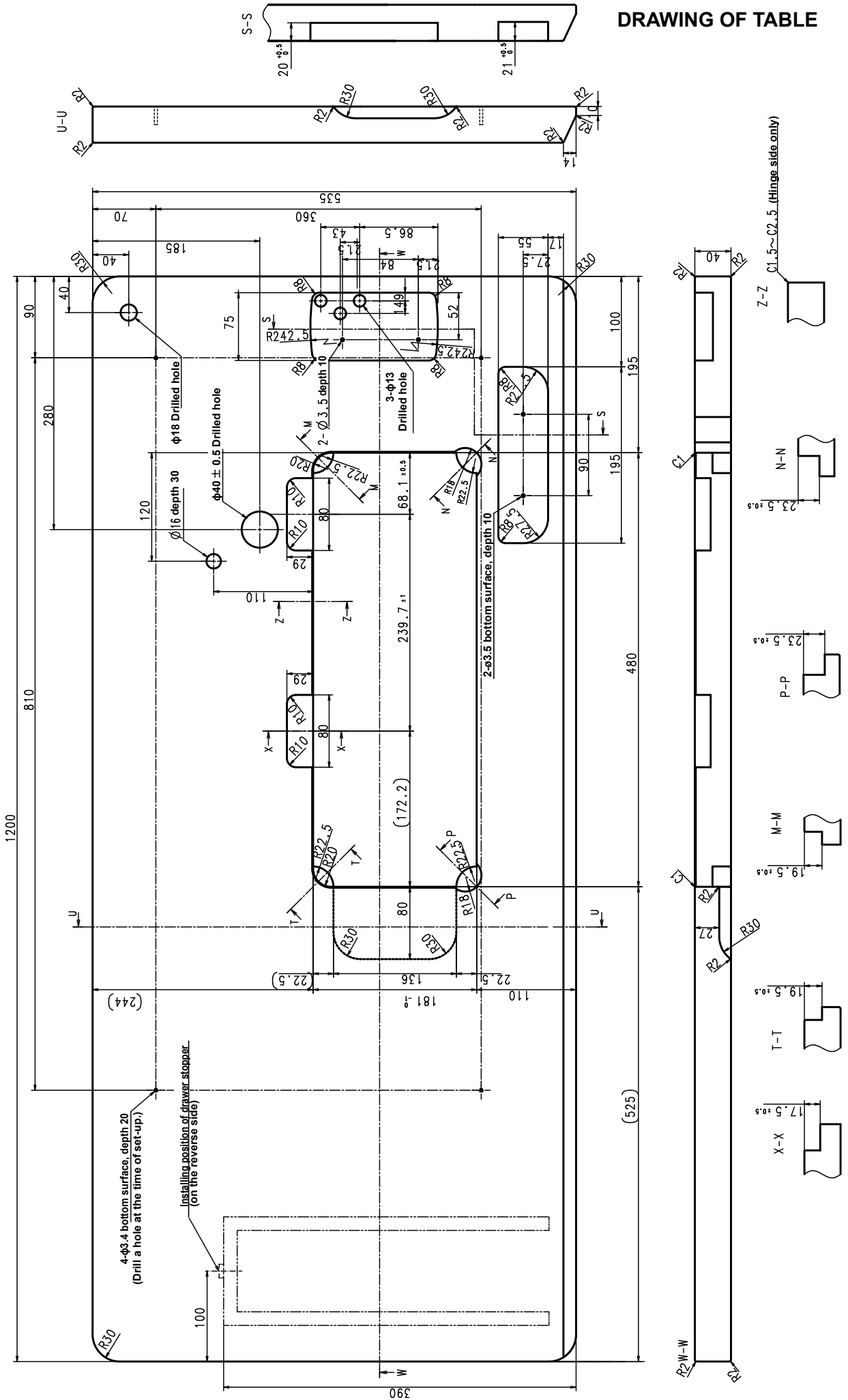

## II. SET-UP

### 1. Installation

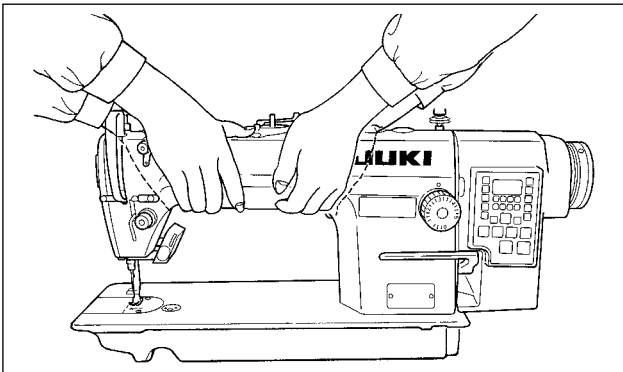

1) Carry the sewing machine with two persons as shown in the figure above.

**(Caution) Do not hold the handwheel.**

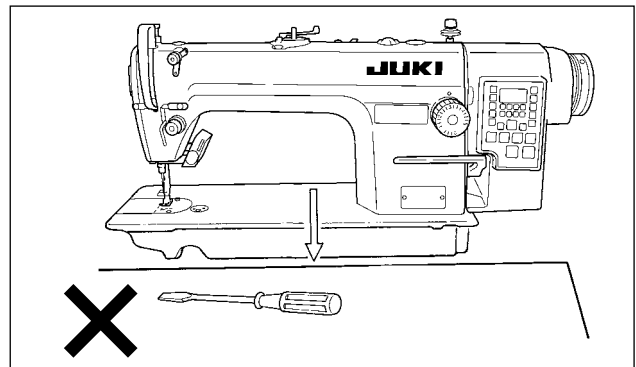

2) Do not put protruding articles such as the screwdriver and the like at the location where the sewing machine is placed.

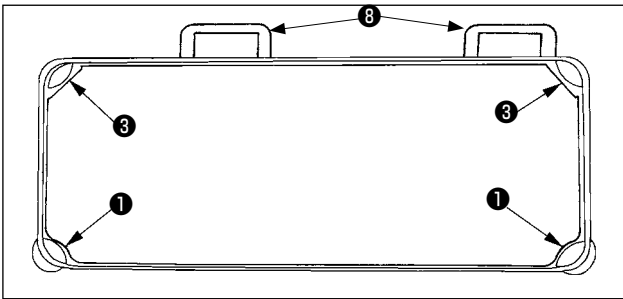

3) Adjust so that the oil pan is supported at the four corners of the table. Mount rubber hinge seat **8** on the table and fix it on the table with a nail.

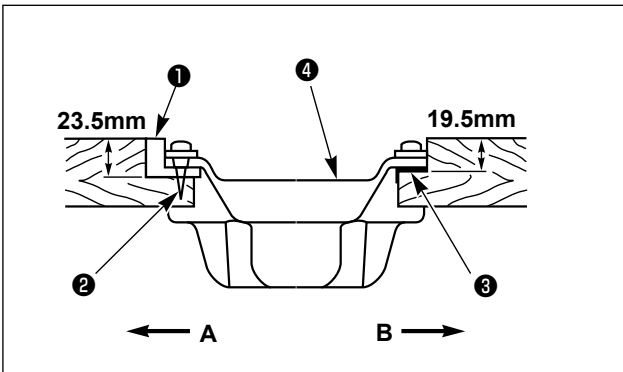

4) Two rubber seats **1** for supporting the head portion on the operator side **A** are fixed on the extended portion of the table by hitting the nail **2**, and the other two rubber cushion seats **3** on the hinge side **B** are fixed by using a rubber-based adhesive. Then, oil pan **4** is placed.

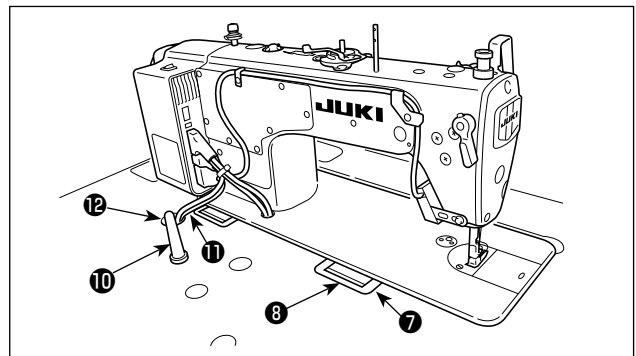
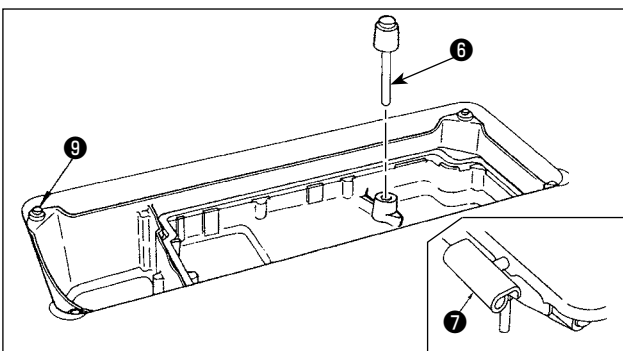

5) Fit knee lifter pressing rod **6**. Fit hinge **7** into the opening in the machine bed, and fit the machine head to table rubber hinge **8** before placing the machine head on cushions **9** on the four corners.

6) Securely attach head support rod **10** to the table until it goes no further.

\* **Be sure to install the machine head support bar supplied with the unit.**

7) Draw out cable **11** of the control box through cable draw-out hole **12** to route it to the underside of the sewing machine table.

## 2. Installing the pedal sensor

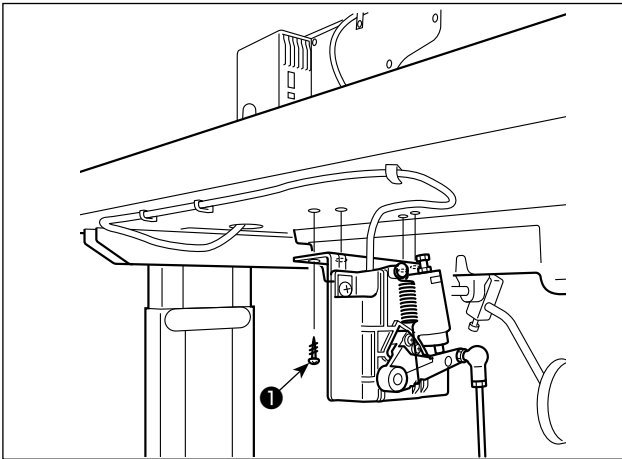

The explanation applies to the case the pedal sensor is installed on the table for the DDL-8100B-7.

- 1) Install the pedal sensor to the table with mounting screws ❶ supplied with the unit. It is necessary to install the pedal sensor at such a position that the connecting rod is perpendicular to the table.
- 2) After the completion of installation of the pedal sensor on the table, place the sewing machine head on the table.

## 3. Connecting the connector

### WARNING :

- To protect against personal injury resulting from abrupt start of the sewing machine, be sure to turn the power OFF, unplug the machine and wait for five minutes or more before installing the pedal sensor.
- To prevent damage of device caused by maloperation and wrong specifications, be sure to connect all the corresponding connectors to the specified places. (If any of the connectors is inserted into a wrong connector, not only the device corresponding to the connector can break but also it can start abruptly, inviting the risk of personal injury.)
- To prevent personal injury caused by maloperation, be sure to lock the connector with lock.
- As for the details of handling respective devices, read carefully the Instruction Manuals supplied with the devices before handling the devices.

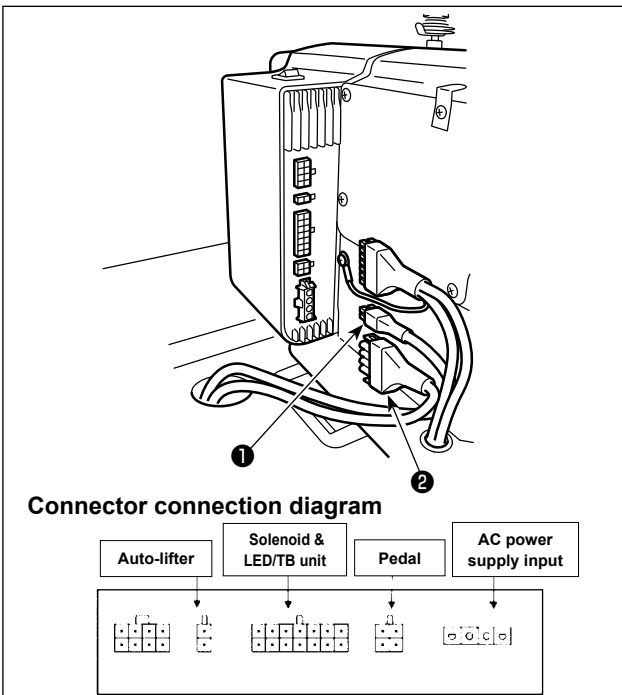

**Do not insert the power plug into the wall outlet.**



**Check to be sure that the power switch is turned OFF.**

- 1) Connect pedal sensor cable ❶ and AC input cable ❷ supplied with the unit to the control box. Refer to the connector connection diagram for connecting ports of the cables.

**Be sure to fully insert the connectors into the corresponding ports until they are locked.**

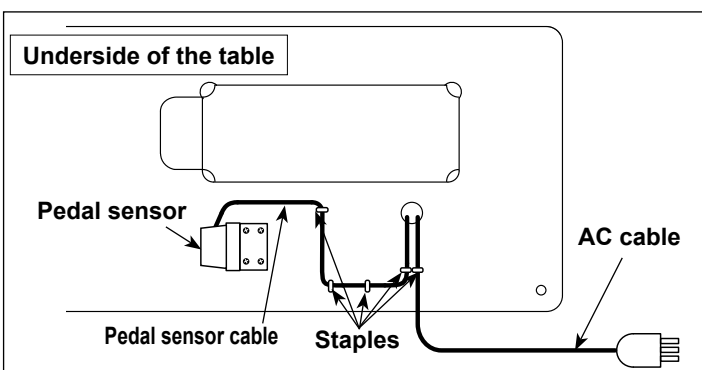

- 2) Fix the pedal cable and AC input cable with a staple.

#### 4. How to install the power plug



##### WARNING :

1. Be sure to attach the ground wire (green/yellow) to the specified location (on the ground side).
2. Take care not to allow terminals to come in contact with each other.

1ø 220V to 240V

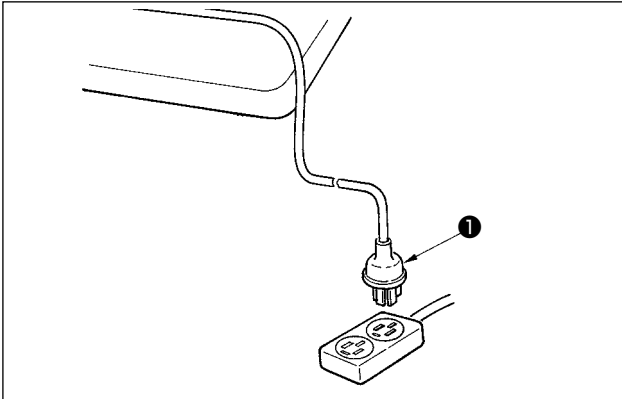
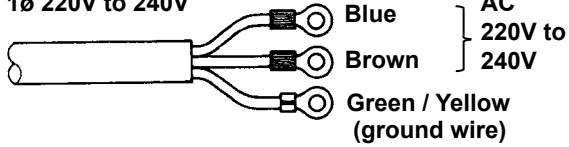

- 1) Connect the power cord to the power plug.  
As shown in the figure, connect the brown and blue wires to the power supply side and the green/yellow one to the grounding side.



1. Be sure to prepare the power plug ❶ which conforms to the safety standard.
2. Be sure to connect the ground lead (green/yellow) to the grounding side.

- 2) Check that the power switch is in the OFF state.  
Then, insert the power plug coming from the power switch into the plug receptacle.



In prior to the connection of the power plug, re-check the supply voltage specification indicated on the control box.

#### 5. Attaching the connecting rod



##### WARNING :

To protect against possible personal injury due to abrupt start of the machine, be sure to start the following work after turning the power off and a lapse of 5 minutes or more.

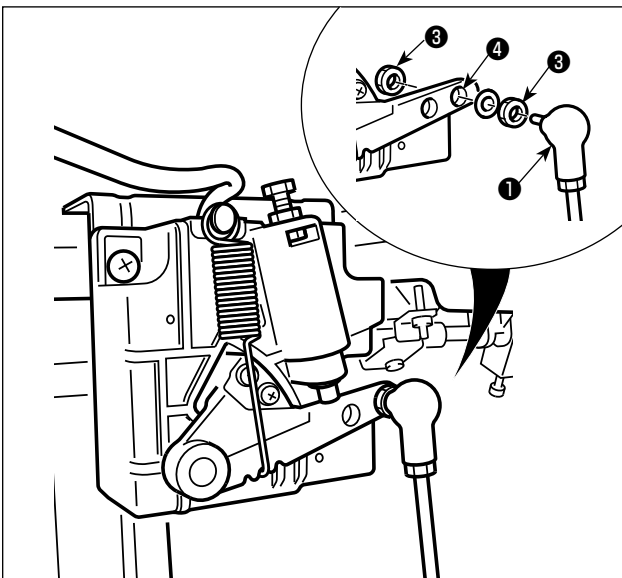

Fix connecting rod ❶ to installing hole ❷ of pedal lever ❸ with nut ❹.

## 6. Winding the bobbin thread

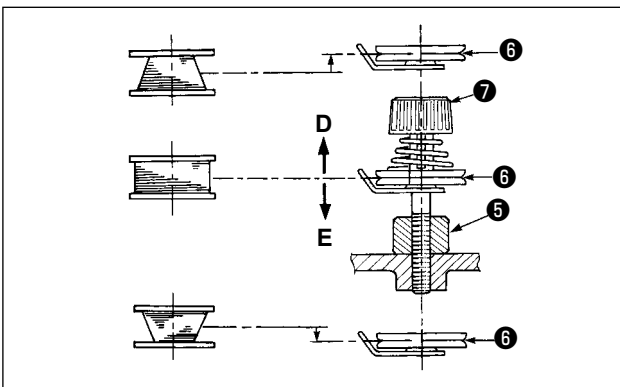
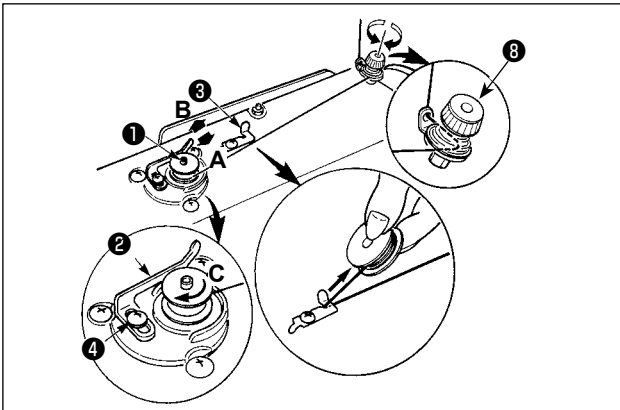

- 1) Insert the bobbin deep into the bobbin winder spindle ① until it will go no further.
- 2) Pass the bobbin thread pulled out from the spool rested on the right side of the thread stand following the order as shown in the figure on the left. Then, wind clockwise the end of the bobbin thread on the bobbin several times.  
(In case of the aluminum bobbin, after winding clockwise the end of the bobbin thread, wind counterclockwise the thread coming from the bobbin thread tension several times to wind the bobbin thread with ease.)
- 3) Press the bobbin winder trip latch ② in the direction of **A** and start the sewing machine. The bobbin rotates in the direction of **C** and the bobbin thread is wound up. The bobbin winder spindle ① automatically as soon as the winding is finished.
- 4) Remove the bobbin and cut the bobbin thread with the thread cut retainer ③.
- 5) When adjusting the winding amount of the bobbin thread, loosen setscrew ④ and move bobbin winding lever ② to the direction of **A** or **B**. Then tighten setscrew ④.

To the direction of **A** : Decrease

To the direction of **B** : Increase

- 6) In case that the bobbin thread is not wound evenly on the bobbin, remove the handwheel, loosen screw ⑤ and adjust the height of bobbin thread tension ⑧.
  - It is the standard that the center of the bobbin is as high as the center of thread tension disk ⑥.
  - Adjust the position of thread tension disk ⑥ to the direction of **D** when the winding amount of the bobbin thread on the lower part of the bobbin is excessive and to the direction **E** when the winding amount of the bobbin thread on the upper part of the bobbin is excessive.  
After the adjustment, tighten screw ⑤.
- 7) To adjust the tension of the bobbin winder, turn the thread tension nut ⑦.



1. When winding the bobbin thread, start the winding in the state that the thread between the bobbin and thread tension disk ⑥ is tense.
2. When winding the bobbin thread in the state that sewing is not performed, remove the needle thread from the thread path of thread take-up and remove the bobbin from the hook.
3. There is the possibility that the thread pulled out from the thread stand is loosened due to the influence (direction) of the wind and may be entangled in the handwheel. Be careful of the direction of the wind.



## 7. Adjusting the height of the knee lifter



### WARNING :

Be sure to turn the power OFF before the following work in order to prevent personal injury due to unintentional starting of the sewing machine.

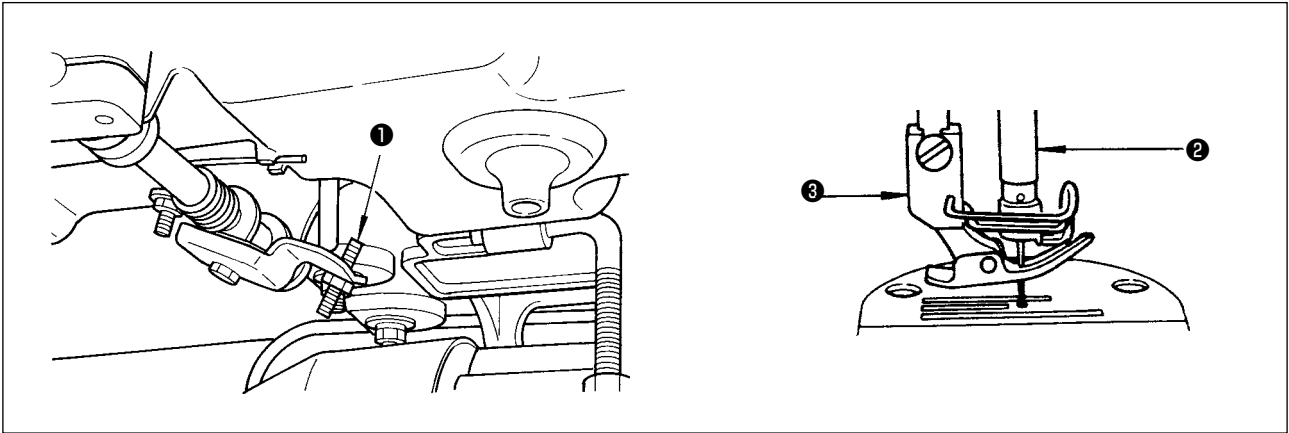

- 1) The standard height of the presser foot lifted using the knee lifter is 10 mm.
- 2) You can adjust the presser foot lift up to 13 mm using knee lifter adjust screw **1**.
- 3) When you have adjusted the presser foot lift to over 10 mm, be sure that the bottom end of needle bar **2** in its lowest position does not hit presser foot **3**.

## 8. Installing the thread stand

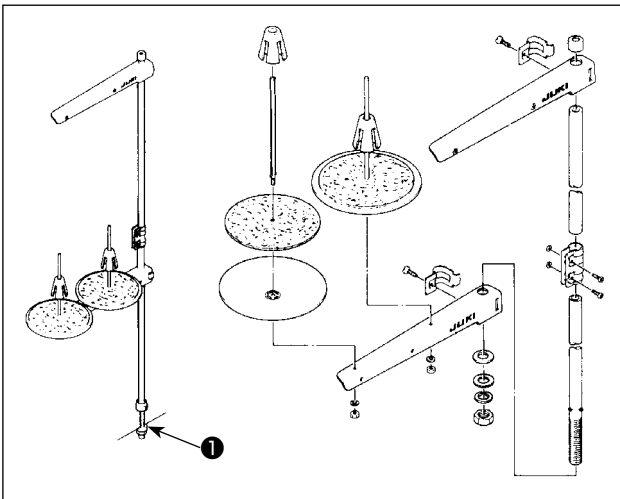

- 1) Assemble the thread stand unit, and insert it in the hole in the machine table.
- 2) Tighten nut **1**.

## 9. Lubrication

### WARNING :



1. Do not connect the power plug until the lubrication has been completed so as to prevent accidents due to abrupt start of the sewing machine,
2. To prevent the occurrence of an inflammation or rash, immediately wash the related portions if oil adheres to your eyes or other parts of your body.
3. If oil is mistakenly swallowed, diarrhea or vomiting may occur. Put oil in a place where children cannot reach.

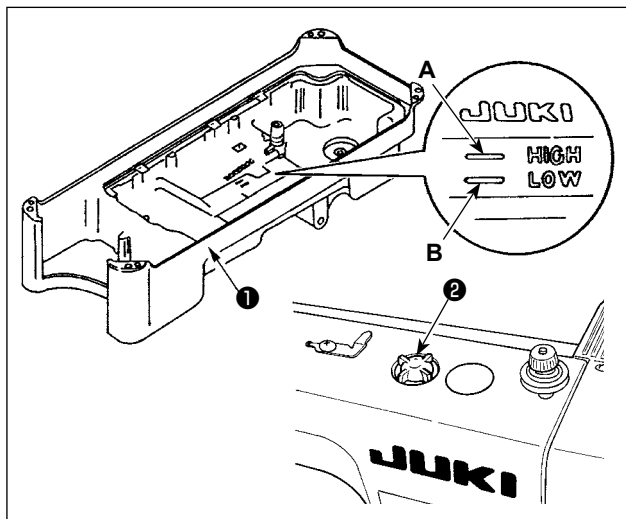

- 1) Before starting the sewing machine, fill oil pan ❶ with JUKI MACHINE OIL #7 up to HIGH mark A.
- 2) Add oil before the oil surface comes down to reach the LOW mark B.
- 3) When you operate the machine after lubrication, you will see splashing oil through oil sight window ❷ if the lubrication is adequate.
- 4) Note that the amount of the splashing oil is unrelated to the amount of the lubricating oil.



1. When you use a new sewing machine or a sewing machine after an extended period of disuse, use the sewing machine after performing break-in at 2,000 sti/min or less.
2. For the oil lubrication, purchase JUKI NEW DEFRIX OIL No. 1 (Part No. : MDFRX1600C0) or JUKI MACHINE OIL #7 (Part No. : MML007600CA).
3. Be sure to lubricate clean oil.
4. When the oil surface is lower than the LOW mark, the oiling may be inconsistent. To prevent inconsistent oiling, add oil before the oil surface comes down to reach the LOW mark.

## 10. Adjusting the amount of oil (oil splashes)



### WARNING :

Be extremely careful about the operation of the machine since the amount of oil has to be checked by turning the hook at a high speed.

### (1) Confirmation of the amount of oil in the hook

#### ❶ Amount of oil (oil splashes) confirmation paper

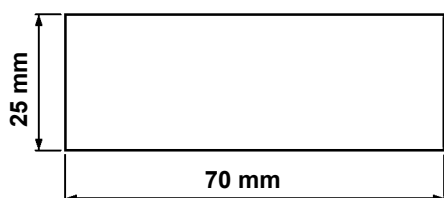

Oil splashes confirmation paper

#### ❷ Position to confirm the amount of oil (oil splashes)

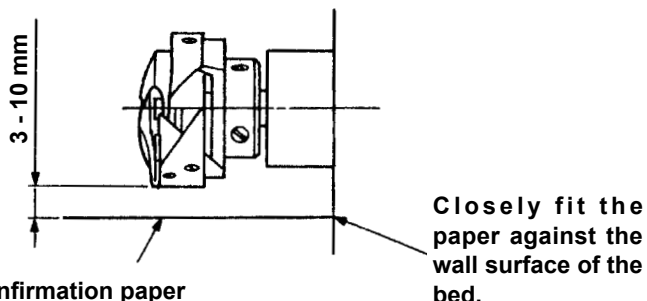

\* When carrying out the procedure described below in 2, remove the slide plate and take extreme caution not to allow your fingers to come in contact with the hook.

- 1) If the machine has not been sufficiently warmed up for operation, make the machine run idle for approximately three minutes. (Moderate intermittent operation)
- 2) Place the amount of oil (oil spots) confirmation paper under the hook immediately after the machine stops running.
- 3) Confirm the height of the oil surface in the oil reservoir is within the range between "HIGH" and "LOW".
- 4) Confirmation of the amount of oil should be completed in five seconds. (Check the period of time with a watch.)

## (2) Adjusting the amount of oil (oil spots) in the hook

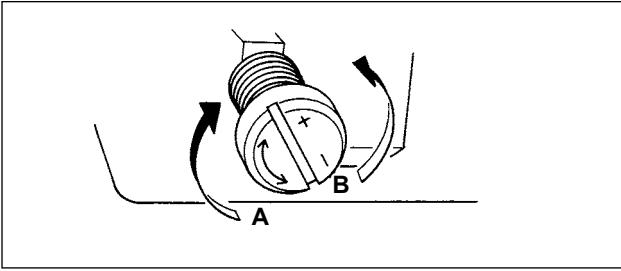

- 1) Turning the oil amount adjustment screw attached on the hook driving shaft front bushing in the “+” direction (in direction **A**) will increase the amount of oil (oil spots) in the hook, or in the “-” direction (in direction **B**) will decrease it.
- 2) After the amount of oil in the hook has been properly adjusted with the oil amount adjustment screw, make the sewing machine run idle for approximately 30 seconds to check the amount of oil in the hook.

## (3) Sample showing the appropriate amount of oil in the hook

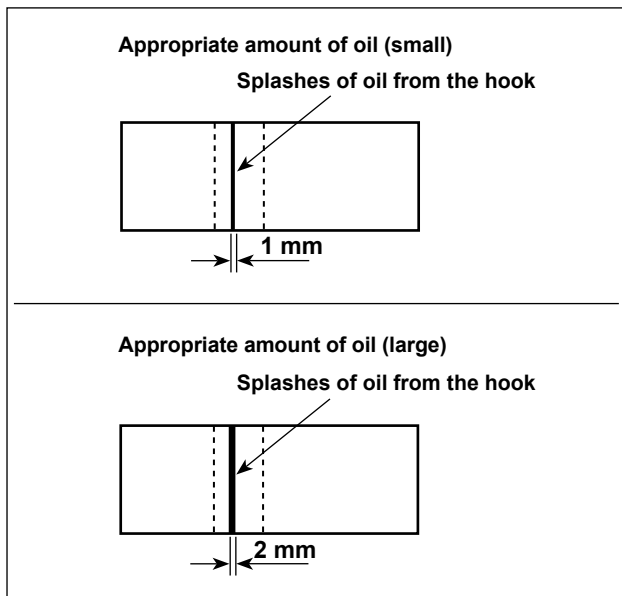

- 1) The amount of oil shown in the samples on the left should be finely adjusted in accordance with sewing processes. Be careful not to excessively increase/decrease the amount of oil in the hook. (If the amount of oil is too small, the hook will be seized (the hook will be hot). If the amount of oil is too much, the sewing product may be stained with oil.)
- 2) Adjust the amount of oil in the hook so that the oil amount (oil splashes) should not change while checking the oil amount three times (on the three sheets of paper).

## (4) Confirmation of the amount of oil supplied to the face plate parts

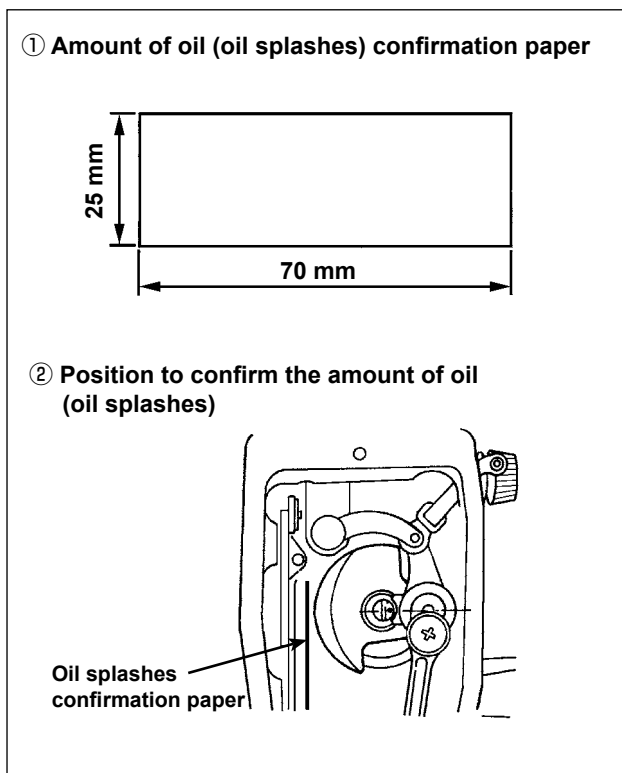

- \* When carrying out the work described below in 2), remove the face plate and take extreme caution not to allow your fingers to come in contact with the thread take-up lever.
- 1) If the machine has not been sufficiently warmed up for operation, make the machine run idle for approximately three minutes. (Moderate intermittent operation)
  - 2) Place the amount of oil (oil spots) confirmation paper under the hook immediately after the machine stops running.
  - 3) Confirm the height of the oil surface in the oil reservoir is within the range between “HIGH” and “LOW”.
  - 4) The time required for the confirmation of the amount of oil (oil splashes) should be completed in ten seconds. (Measure the period of time with a watch.)

## (5) Adjusting the amount of oil supplied to the face plate parts

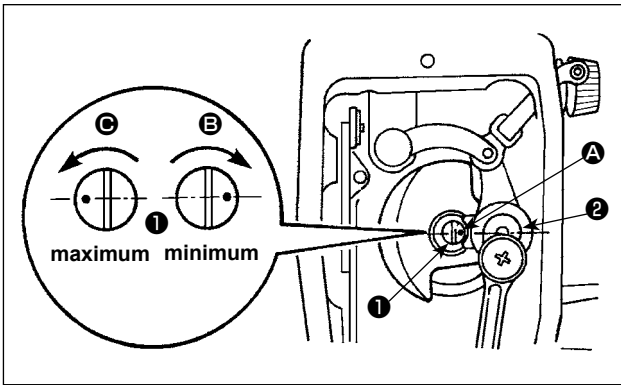

- 1) Adjust the amount of oil supplied to the thread take-up and needle bar crank ② by turning adjust pin ①.
- 2) The minimum amount of oil is reached when marker dot ① is brought close to needle bar crank ② by turning the adjust pin in direction ③.
- 3) The maximum amount of oil is reached when marker dot ① is brought to the position just opposite from the needle bar crank by turning the adjust pin in direction ④.

## (6) Sample showing the appropriate amount of oil supplied to the face plate parts

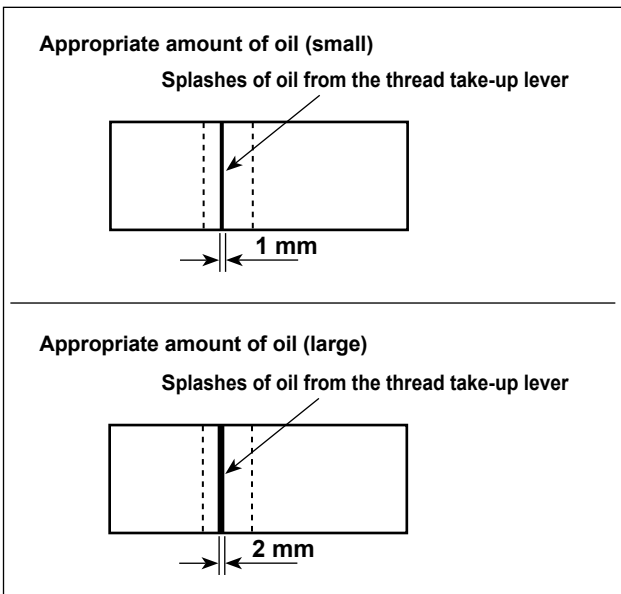

- 1) The state given in the figure shows the appropriate amount of oil (oil splashes). It is necessary to finely adjust the amount of oil in accordance with the sewing processes. However, do not excessively increase/decrease the amount of oil in the hook. (If the amount of oil is too small, the hook will be seized (the hook will be hot). If the amount of oil is too much, the sewing product may be stained with oil.)
- 2) Adjust the amount of oil in the hook so that the oil amount (oil splashes) should not change while checking the oil amount three times (on the three sheets of paper).

## 11. Attaching the needle



### WARNING :

Be sure to turn the power OFF before the following work in order to prevent personal injury due to unintentional starting of the sewing machine.

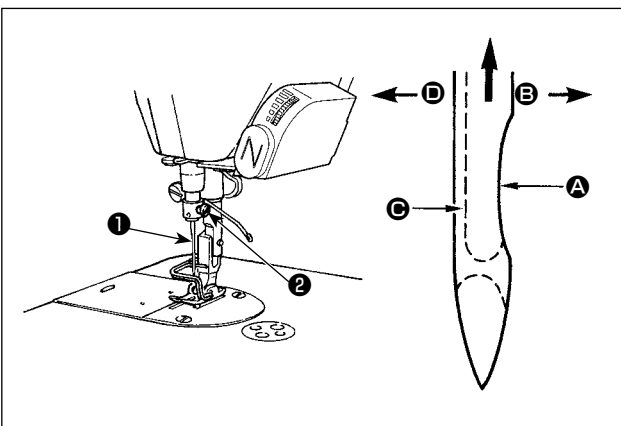

Use the specified needle for the machine. Use the proper needle in accordance with the thickness of thread used and the kinds of the materials.

- 1) Turn the handwheel until the needle bar reaches the highest point of its stroke.
- 2) Loosen screw ②, and hold needle ① with its indented part ① facing exactly to the right in direction ②.
- 3) Insert the needle fully into the hole in the needle bar in the direction of the arrow until the end of hole is reached.
- 4) Securely tighten screw ②.

- 5) Check that long groove ③ of the needle is facing exactly to the left in direction ④.



When polyester filament thread is used, if the indented part of the needle is tilted toward operator's side, the loop of thread becomes unstable. As a result, hangnail of thread or thread breakage may occur. For the thread that such phenomenon is likely to occur, it is effective to attach the needle with its indented part slightly slanting on the rear side.

## 12. Setting the bobbin into the bobbin case

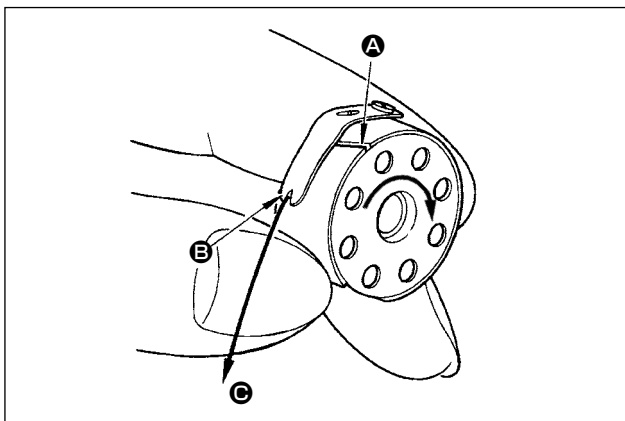

- 1) Pass the thread through thread slit **A**, and pull the thread in direction **C**. By so doing, the thread will pass under the tension spring and come out from notch **B**.
- 2) Check that the bobbin rotates in the direction of the arrow when thread is pulled.

## 13. Adjusting the stitch length

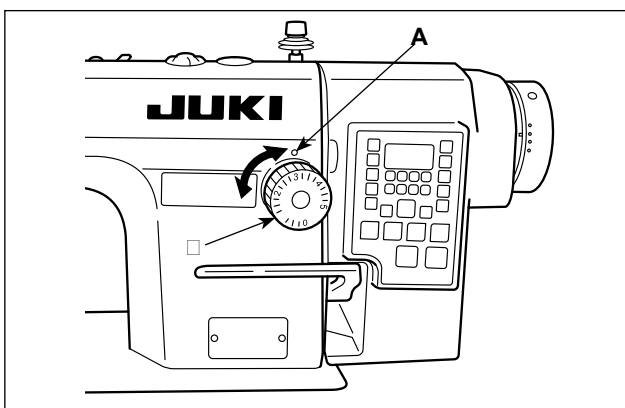

\* The dial calibration is in millimeters.

- 1) Turn stitch length dial **1** in the direction of the arrow, and align the desired number to marker dot **A** on the machine arm.

## 14. Presser foot pressure

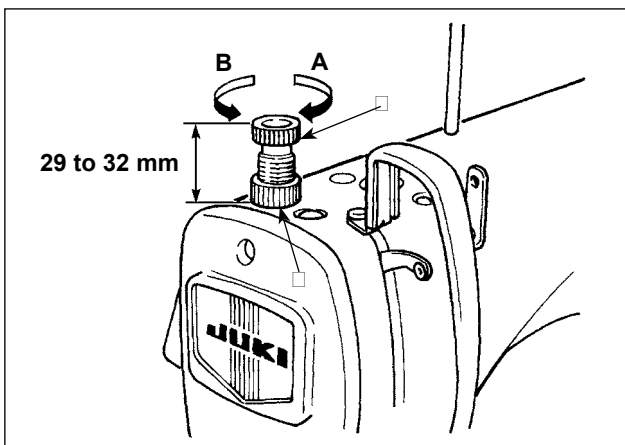

- 1) Loosen nut **2**. As you turn presser spring regulator **1** clockwise (in direction **A**), the presser foot pressure will be increased.
- 2) As you turn the presser spring regulator counter-clockwise (in direction **B**), the pressure will be decreased.
- 3) After adjustment, tighten nut **2**.

The standard value of the pressure regulating thumb screw is 29 to 32 mm.

## 15. Hand lifter

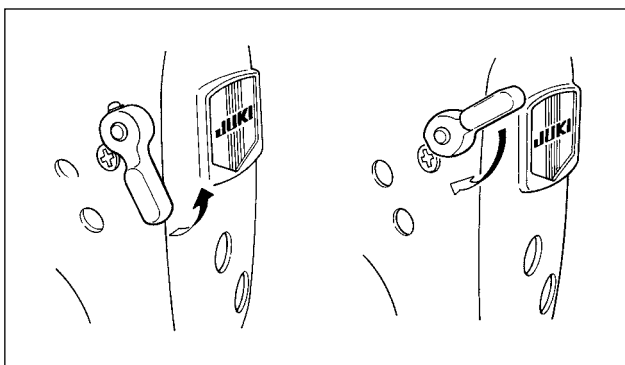

- 1) The presser foot is lifted by moving the lever upward.
- 2) The presser foot is lowered by moving the lever downward.

## 16. Adjusting the height of the presser bar



### WARNING :

Be sure to turn the power OFF before the following work in order to prevent personal injury due to unintentional starting of the sewing machine.

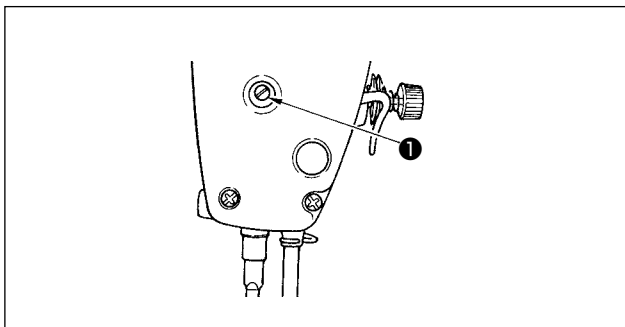

- 1) Loosen setscrew ❶, and adjust the presser bar height or the angle of the presser foot.
- 2) After adjustment, securely tighten the setscrew ❶.

## 17. Threading the machine head



### WARNING :

Be sure to turn the power OFF before the following work in order to prevent personal injury due to unintentional starting of the sewing machine.

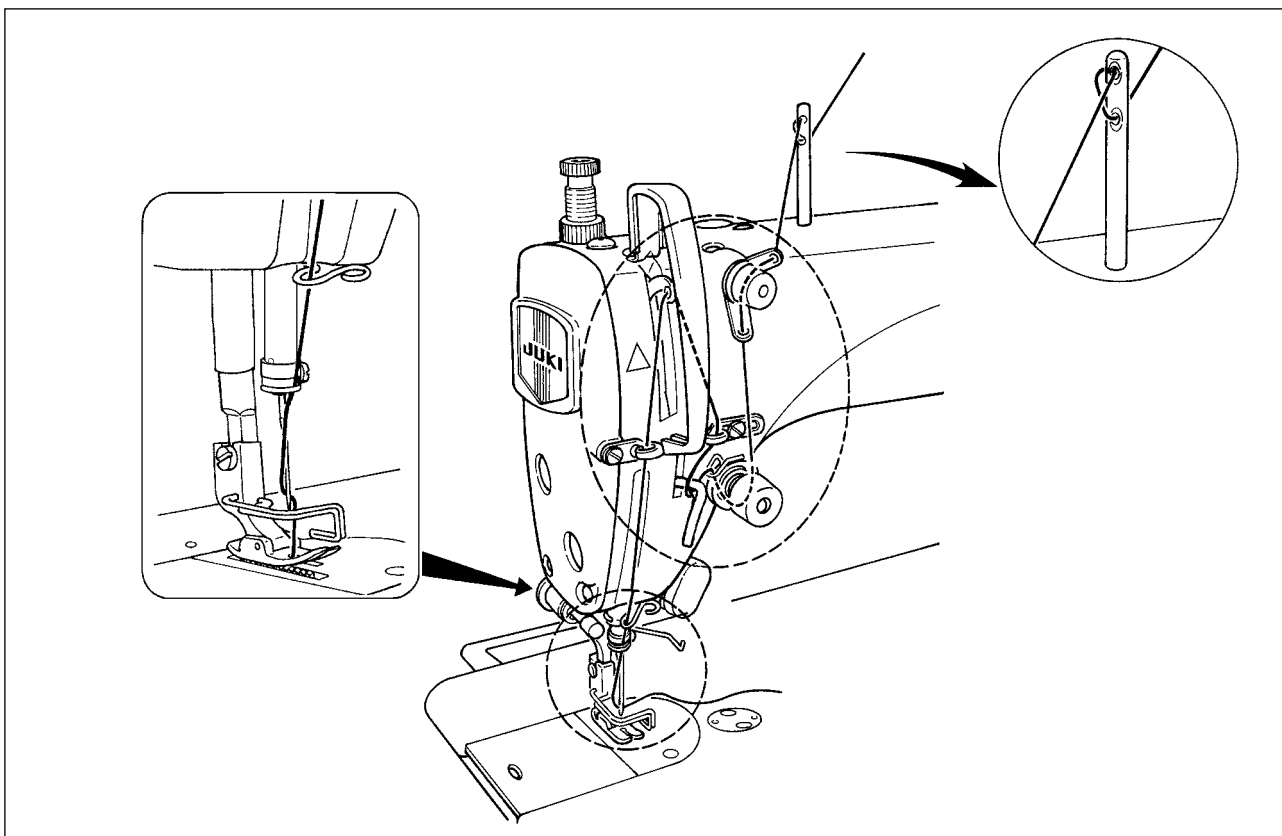

## 18. Thread tension

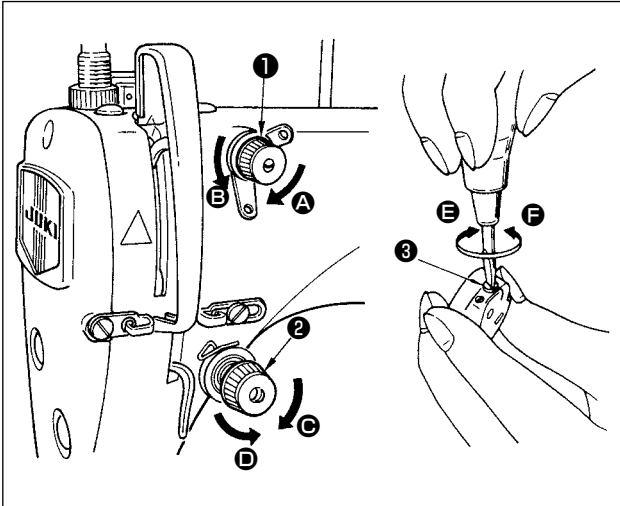

### (1) Adjusting the needle thread tension

- 1) The length of thread remaining at the needle tip after thread trimming is shortened by turning tension regulating nut No. 1 ① clockwise in direction A.
- 2) It is lengthened by turning the nut counterclockwise in direction B.
- 3) The needle thread tension is increased by turning tension regulating nut No. 2 ② clockwise in direction C.
- 4) It is decreased by turning the nut counterclockwise in direction D.

### (2) Adjusting the bobbin thread tension

- 1) The bobbin thread tension is increased by turning tension regulating screw ③ clockwise in direction E.
- 2) It is decreased by turning the screw counterclockwise in direction F.

## 19. Thread take-up spring

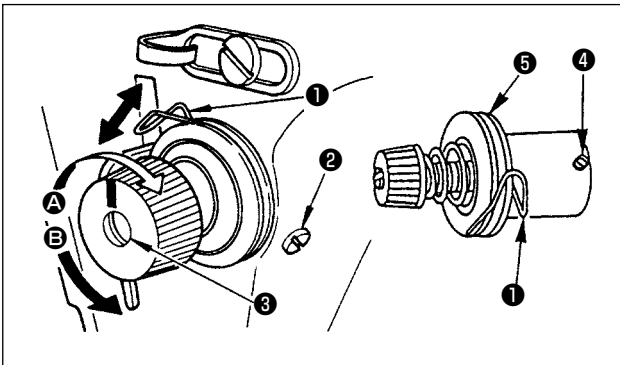

### (1) Changing the stroke of thread take-up spring ①

- 1) Loosen setscrew ②.
- 2) As you turn tension post ③ clockwise (in direction A), the stroke of the thread take-up spring will be increased.
- 3) As you turn the knob counterclockwise (in direction B), the stroke will be decreased.

### (2) Changing the pressure of thread take-up spring ①

- 1) Loosen setscrew ②, and remove thread tension ③.
- 2) Loosen setscrew ④.
- 3) As you turn tension post ③ clockwise (in direction A), the pressure will be increased.
- 4) As you turn the tension post counterclockwise (in direction B), the pressure will be decreased.

## 20. Adjusting the thread take-up stroke



### WARNING :

Be sure to turn the power OFF before the following work in order to prevent personal injury due to unintentional starting of the sewing machine.

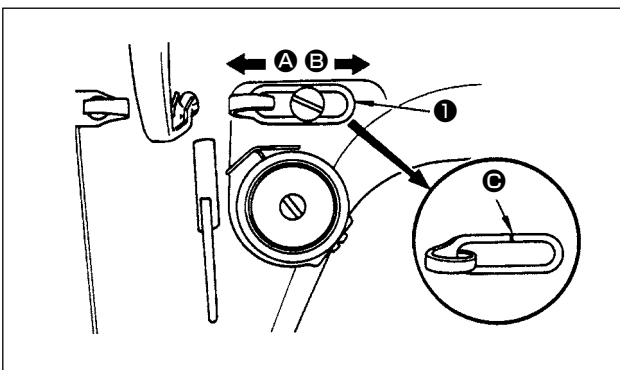

- 1) When sewing heavy-weight materials, move thread guide ① to the left (in direction A) to increase the length of thread pulled out by the thread take-up.
- 2) When sewing light-weight materials, move thread guide ① to the right (in direction B) to decrease the length of thread pulled out by the thread take-up.
- 3) Normally, thread guide ① is positioned in a way that marker line C is aligned with the center of the screw.

## 21. Needle-to-hook relationship



### WARNING :

Be sure to turn the power OFF before the following work in order to prevent personal injury due to unintentional starting of the sewing machine.

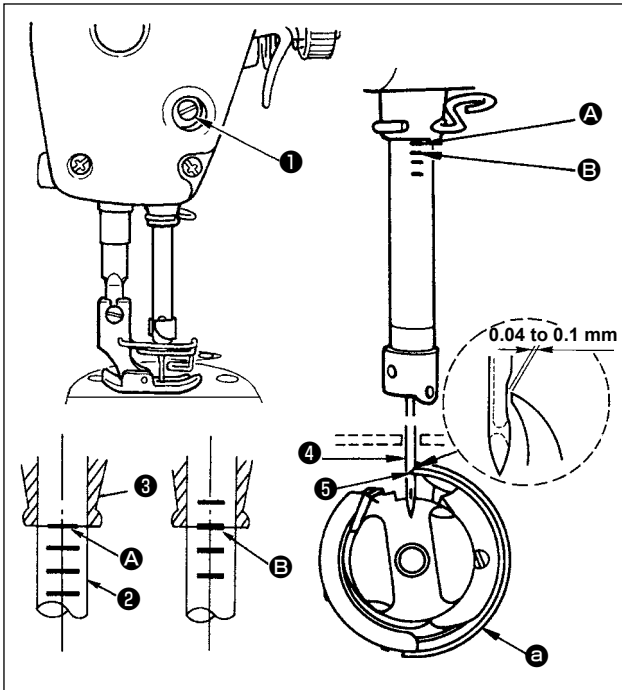

(1) Adjust the timing between the needle and the hook as follows :

- 1) Turn the handwheel to bring the needle bar down to the lowest point of its stroke, and loosen setscrew ①.

(Adjusting the needle bar height)

- 2) Align marker line ① on needle bar ② with the bottom end of needle bar lower bushing ③, then tighten setscrew ①.

(Adjusting position of the hook ③)

- 3) Loosen the three hook setscrews, turn the handwheel and align marker line ① on ascending needle bar ② with the bottom end of needle bar lower bushing ③.
- 4) After making the adjustments mentioned in the above steps, align hook blade point ⑤ with the center of needle ④. Provide a clearance of 0.04 mm to 0.1 mm (reference value) between the needle and the hook, then securely tighten setscrews in the hook.



If the clearance between the blade point of hook and the needle is smaller than the specified value, the blade point of hook will be damaged. If the clearance is larger, stitch skipping will result.

## 22. Height of the feed dog



### WARNING :

Be sure to turn the power OFF before the following work in order to prevent personal injury due to unintentional starting of the sewing machine.

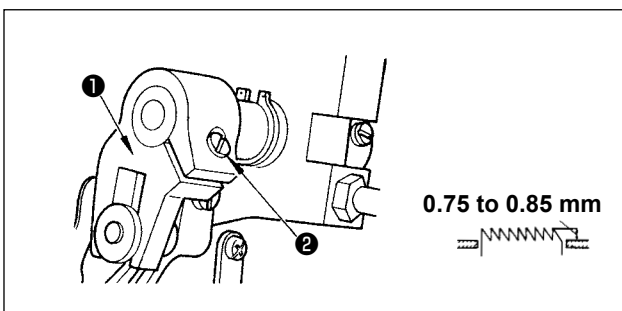

To adjust the height of the feed dog :

- ① Loosen screw ② of crank ①.
- ② Move the feed bar up or down to make adjustment.
- ③ Securely tighten screw ②.



If the clamping pressure is insufficient, the motion of the forked portion becomes heavy.



## 23. Tilt of the feed dog



### WARNING :

Be sure to turn the power OFF before the following work in order to prevent personal injury due to unintentional starting of the sewing machine.

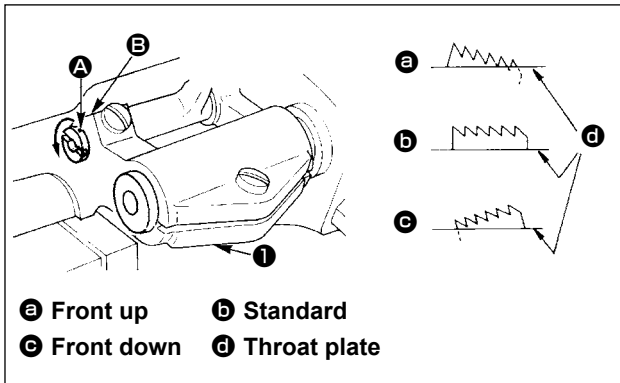

- 1) The standard tilt (horizontal) of the feed dog is obtained when marker dot **A** on the feed bar shaft is aligned with marker dot **B** on feed rocker **1**.
- 2) To tilt the feed dog with its front up in order to prevent puckering, loosen the setscrew, and turn the feed bar shaft 90° in the direction of the arrow, using a screwdriver.
- 3) To tilt the feed dog with its front down in order to prevent uneven material feed, turn the feed bar shaft 90° in the opposite direction from the arrow.



Whenever the feed dog tilt is adjusted, the feed dog height will be changed. So, it is necessary to check the height after tilt adjustment.

## 24. Adjusting the feed timing



### WARNING :

Be sure to turn the power OFF before the following work in order to prevent personal injury due to unintentional starting of the sewing machine.

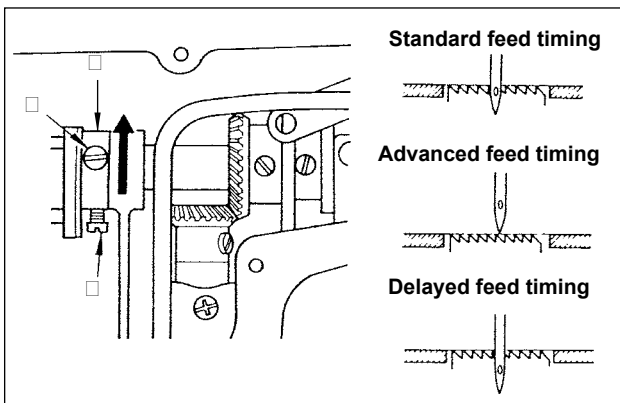

- 1) Loosen screws **2** and **3** in feed eccentric cam **1**, move the feed eccentric cam in the direction of the arrow or opposite direction of the arrow, and firmly tighten the screws.
- 2) For the standard adjustment, adjust so that the top surface of feed dog and the top end of needle eyelet are flush with the top surface of throat plate when the feed dog descends below the throat plate.
- 3) To advance the feed timing in order to prevent uneven material feed, move the feed eccentric cam in the direction of the arrow.
- 4) To delay the feed timing in order to increase stitch tightness, move the feed eccentric cam in the opposite direction from the arrow.



Be careful not to move the feed eccentric cam too far, or else needle breakage may result.

## 25. Cunter knife



### WARNING :

Be sure to turn the power OFF before the following work in order to prevent personal injury due to unintentional starting of the sewing machine.



When sharpening again the knife blade, extra special care must be taken on the handling of the knife.

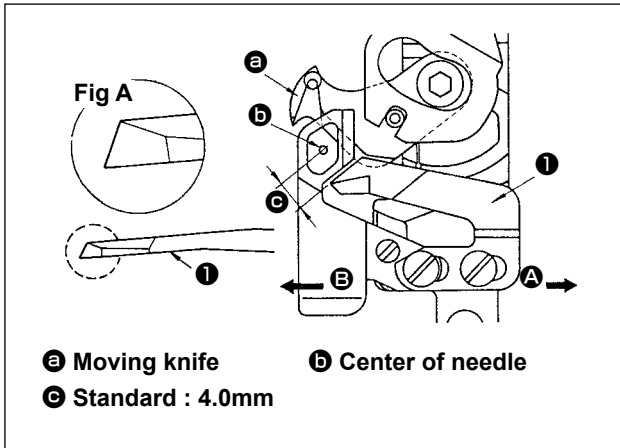

If the knife does not cut thread sharply, immediately re-sharpen counter knife ① as illustrated in Fig. A and re-install it properly.

- 1) If the mounting position of the counter knife is moved in direction **A** from the standard mounting position, the thread length after thread trimming will be increased accordingly.
- 2) If the mounting position is moved in direction **B**, the thread length will be decreased accordingly.

[DDL-8100B-7R]

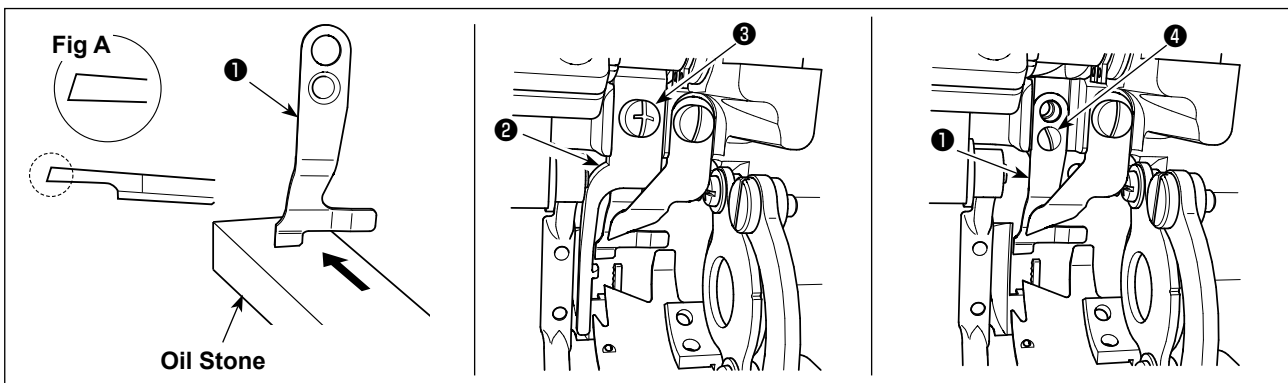

\* In the case the thread cannot be trimmed sharply, re-sharpen counter knife ① as illustrated in Fig. A before the knife has become dull and re-place it correctly.

- 1) Loosen setscrew ② of bobbin case opening lever ①, and remove the bobbin case opening lever.
- 2) Loosen setscrew ④, and remove counter knife ③.
- 3) To install the counter knife, follow the above procedure in reverse order.
- 4) When attaching the bobbin case opening lever, tighten the setscrew while pressing the lever in direction **A**.

## 26. Pedal pressure and pedal stroke



### WARNING :

Be sure to turn the power OFF before the following work in order to prevent personal injury due to unintentional starting of the sewing machine.

For General Application

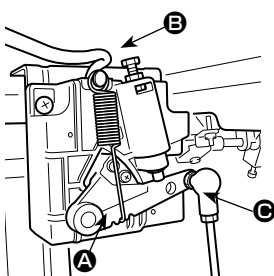

Adjust the force required to operate the foot pedal  
 Spring **A** : Downward force adjustment  
 Bolt **B** : Heeling back force adjustment  
 Hole **C** : Pedal stroke adjustment

## 27. Adjustment of the pedal



### WARNING :

Be sure to turn the power OFF before the following work in order to prevent personal injury due to unintentional starting of the sewing machine.

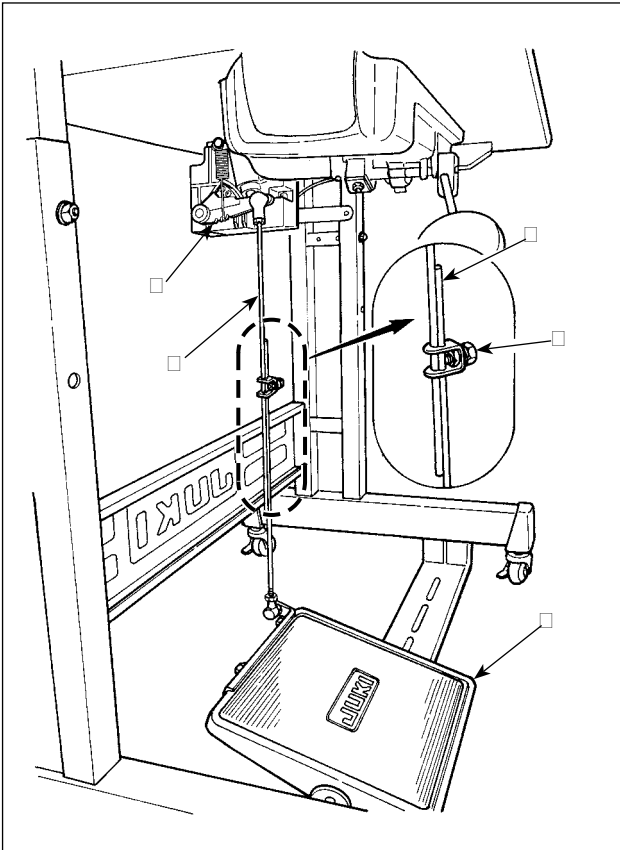

### (1) Installing the connecting rod

- 1) Move pedal **3** to the right or left as illustrated by the arrows so that motor control lever **1** and connecting rod **2** are straightened.

### (2) Adjusting the pedal angle

- 1) The pedal tilt can be freely adjusted by changing the length of the connecting rod.
- 2) Loosen adjust screw **4**, and adjust the length of connecting rod **5**.

## 28. Marker dots on the handwheel

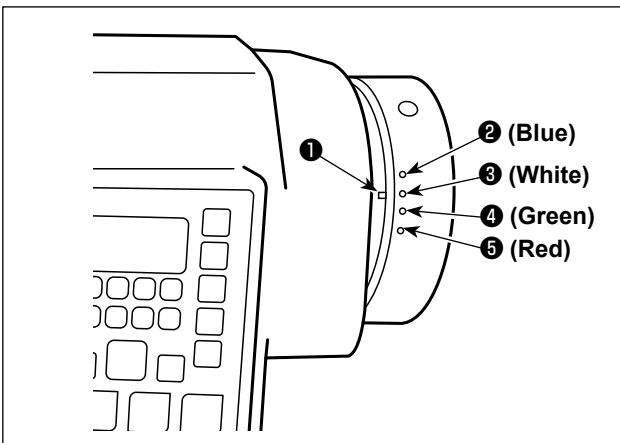

The upper stop position of the needle bar is reached when marker dot **1** on the cover is aligned with white marker dot **3** on the handwheel.

The operating timing of the thread trimming cam is when marker dot **1** on the cover is aligned with red marker dot **5** on the handwheel.

### III. FOR THE OPERATOR

#### 1. Operating procedure of the sewing machine

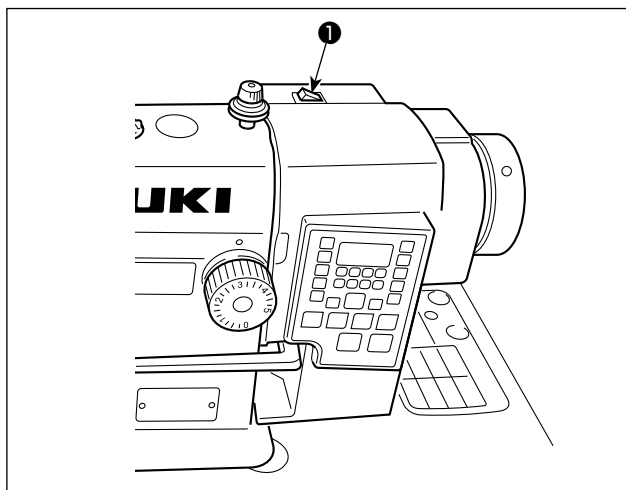

- 1) Press ON button **1** of the power switch to turn ON the power.  
The power switch is in its ON state when the "I" mark is pressed. It is in its OFF state when the "O" mark is pressed.

**Caution** If the power indicator LED on the panel does not light up after having turned ON the power switch, immediately turn OFF the power switch and check the supply voltage. In addition, in such a case as this, re-turn ON the power switch when 2 to 3 minutes or more have passed after turning OFF the power switch.

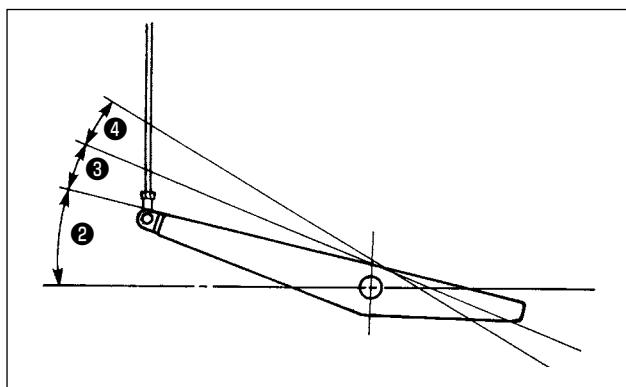

- 2) When the needle bar is not in UP position, it automatically turns to the UP position.

**Caution** When turning ON the power, the needle bar moves. Do not put your hands or things under the needle.

- 3) The pedal is operated in the following four steps:
  - a. The machine runs at low sewing speed when you lightly depress the front part of the pedal. **2**
  - b. The machine runs at high sewing speed when you further depress the front part of the pedal. **2** (If the automatic reverse feed stitching has been preset, the machine runs at high speed after it completes reverse feed stitching.)

- c. The machine stops (with its needle up or down) when you reset the pedal to its original position.
- d. The machine trims threads when you fully depress the back part of the pedal. **4**

\* When the auto-lifter (AK device) is used, one more operating switch is provided between the sewing machine stop switch and thread trimming switch. The presser foot goes up when you lightly depress the back part of the pedal **3**, and if you further depress the back part **4**, the thread trimmer is actuated. When starting sewing from the state that the presser foot has been lifted with the Auto-lifter and you depress the back part of the pedal, the presser foot only comes down.

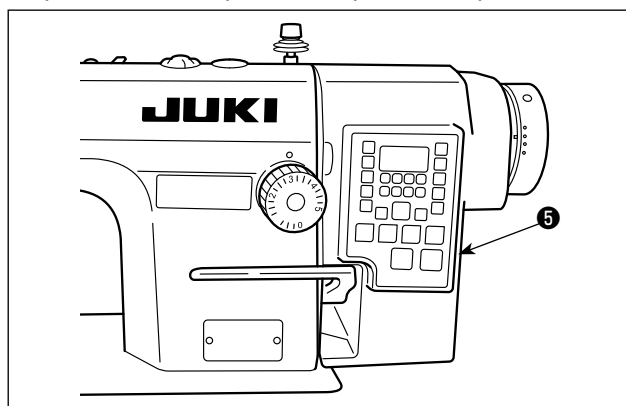

- 4) Reverse feed stitching at the beginning of sewing, reverse feed stitching at the end of sewing and various sewing patterns can be set on built-in panel **5** of the machine head.

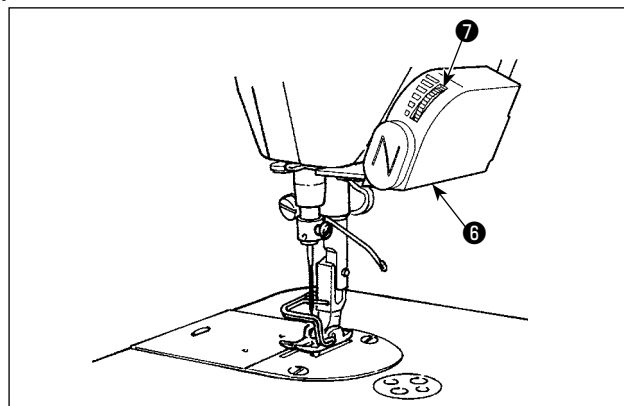

- 5) When one-touch type reverse feed switch **6** is pressed, the sewing machine performs reverse feed stitching. The quantity of light of the LED can be adjusted by turning control knob **7**.

- 6) When sewing is completed, press OFF button **1** of the power switch to turn OFF the power switch after confirming that the sewing machine has stopped.

**Caution** In the case the machine is not used for a long time, remove the power plug from the plug receptacle.

## 2. Operation panel built in the machine head

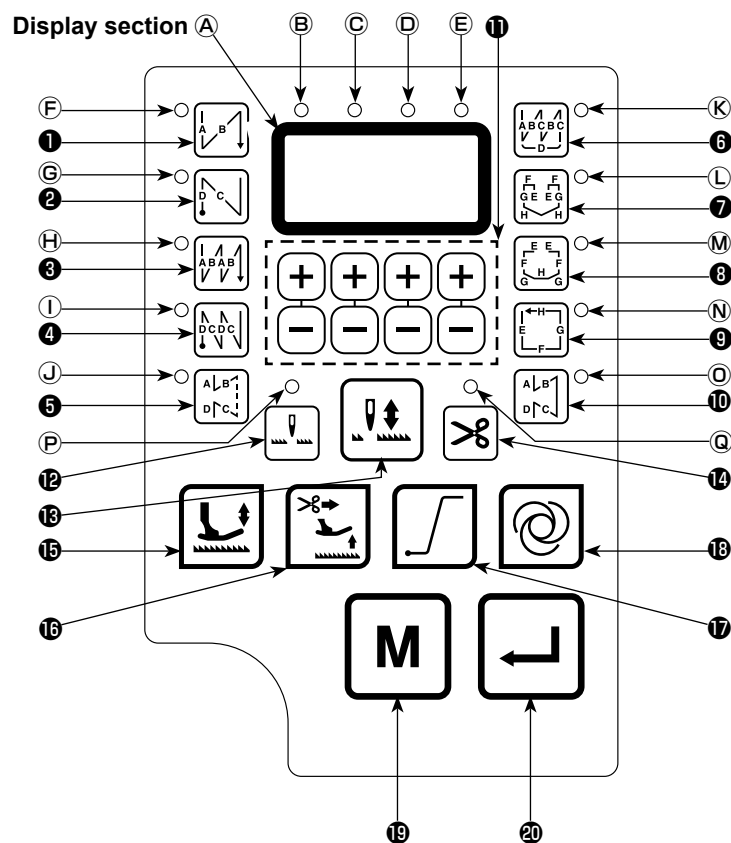

①		Used to change over the automatic reverse feed stitching at the beginning of sewing between enable and disable	⑪		Used to change the contents displayed on the display section
②		Used to change over the automatic reverse feed stitching at the end of sewing between enable and disable	⑫		Used to change over the needle bar stop position at the time of stopping sewing between up and down
③		Used to change over the automatic double reverse feed stitching at the beginning of sewing between enable and disable	⑬		Used to carry out compensating stitching in half-stitch steps
④		Used to change over the automatic double reverse feed stitching at the end of sewing between enable and disable	⑭		Used to change over the thread trimming operation between enable and disable
⑤		Used to change over the reverse feed stitching pattern between enable and disable	⑮		Used to change over the auto-lifter function, while the pedal is in its neutral position, between enable and disable <sup>*1</sup>
⑥		Used to change over the overlapped stitching pattern between enable and disable	⑯		Used to change over the auto-lifter function after thread trimming between enable and disable <sup>*1</sup>
⑦		Used to change over the constant-dimension stitching pattern between enable and disable	⑰		Used to change over the soft-start function between enable and disable
⑧			⑱		Used to change over the operation mode to the function setting mode
⑨			⑳		Used to confirm the settings changed under the function setting mode
⑩					

<sup>\*1</sup> The status of switches ⑮ and ⑯ is changed over by keeping them held pressed for three seconds.

### 3. Operating procedure of the sewing pattern



Refer to the Instruction Manual for each operation panel for how to operate sewing patterns using other operation panel than the built-in panel of the machine head.

#### (1) Reverse feed stitching pattern

Reverse feed stitching at sewing start and reverse feed stitching at sewing end can be separately programmed.

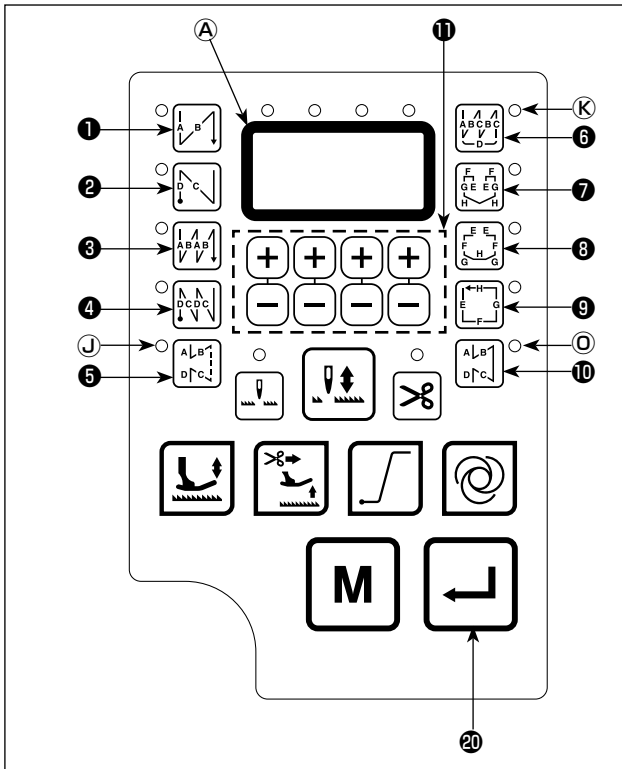

#### [Setting procedure of the reverse feed stitching]

1) Effective/ineffective of the reverse feed stitching

pattern can be changed over by pressing switch **5**.

When the reverse feed stitching pattern is enabled, LED lights up and the display section **A** shows the number of reverse feed stitches at the beginning of sewing and that at the end of sewing.

Use and switches **11** to change the number of stitches for the target process (A, B, C or D). (The number of stitches that can be set is 0 to 15.)

The numbers of stitches for processes A, B, C and D are displayed on display section **A** from left to right in the order from A to D.

2) Enable/disable of the reverse feed stitching at

the beginning of sewing is set by pressing switch **1**.

Enable/disable of the reverse feed stitching at the end of sewing is set by pressing switch **2**.

Enable/disable of the double reverse feed stitching at the beginning of sewing is set by pressing switch **3**.

Enable/disable of the double reverse feed stitching at the end of sewing is set by pressing switch **4**.

#### (2) Overlapped stitching pattern

Overlapped stitching pattern can be programmed.

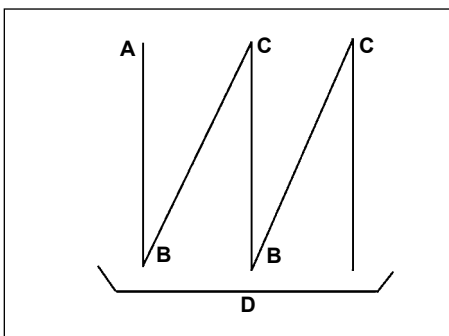

A : Number of stitches of normal stitching setting

0 to 15 stitches

B : Number of stitches of reverse stitching setting

0 to 15 stitches

C : Number of stitches of normal stitching setting

0 to 15 stitches

D : Number of times of repetition

0 to 15 times



When process D is set to 5 times, the sewing is repeated as A → B → C → B → C.

1) Effective/ineffective of the overlapped stitching pattern can be changed over by pressing switch **6**.

When the overlapped stitching pattern is rendered effective, LED lights up.

2) Press and switches **11** to change the number of stitches for target process (A, B, C or D).

### (3) Constant-dimension stitching pattern

The constant-dimension stitching pattern can be set.

#### [How to set the constant-dimension stitching]

##### \* Straight stitching

- 1) Enable/disable of the constant-dimension stitching pattern can be changed over by pressing  switch ⑩.



When the constant-dimension stitching pattern is enabled, LED ⑩ lights up.

Immediately after the constant-dimension stitching is enabled, the numbers of reverse feed stitching processes (A, B, C and D) are displayed on the display section ①.

- 2) When switch  ⑳ is pressed, the content shown on display section is changed over to the number of stitches for the constant-dimension stitching.

The number of stitches (0 to 99) for the constant-dimension stitching can be selected by pressing  switch ⑪.

##### \* Others

- 1) Enable/disable of each stitching pattern can be changed over by pressing  switch ⑦,  switch ⑧ or  switch ⑨.

Immediately after one of the stitching patterns is enabled, the numbers of reverse feed stitching processes (A, B, C and D) are displayed on the display section ①.

- 2) When switch  ⑳ is pressed, the display section ① changes its display to the number of stitches for the constant-dimension stitching process (EF) is displayed.

The number of stitches for the process (EF) can be set by pressing  switch ⑪.

- 3) Then, the content shown on display section ① is changed over to the number of stitches for the constant-dimension stitching process (GH) by pressing switch  ⑳.

The number of stitches (0 to 99) for the process (GH) can be set by pressing  switch ⑪.

- 4) When switch  ⑳ is pressed, the content shown on display section ① is changed over to the numbers of stitches for the reverse feed stitching processes (A, B, C and D).

## 4. Setting of functions

Functions can be selected and specified.



Refer to the Instruction Manual for each operation panel for how to operate sewing patterns using other operation panel than the built-in panel of the machine head.

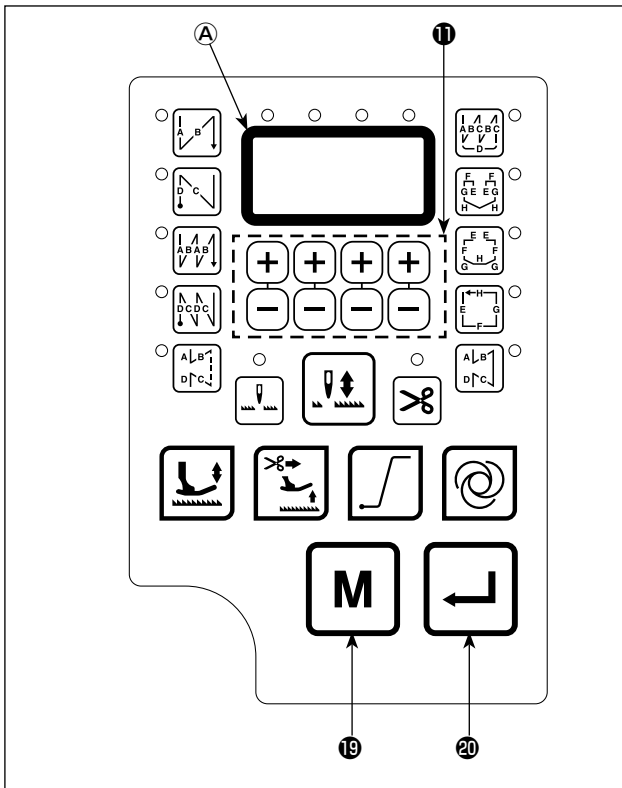

- 1) Press **M** switch ⑱.

The content on display section ① is changed over to display function setting number (P-\*\*). (The display item which was previously changed is displayed unless the power has not been turned off after the previous change.)

- \* If the screen display does not change, re-carry out operation described in step 1).



Be sure to re-turn ON the power switch when ten or more seconds have passed after turning it OFF. If the power switch is re-turned ON immediately after turning it OFF, the sewing machine may fail to operate normally. In such a case, be sure to turn ON the power switch again properly.

- 2) To change the function setting number press **+ -** switch ⑲ and change it to a desired one.
- 3) After having changed the function setting number to a desired one, press switch **confirm** ⑳ to display the set value of the selected function setting No.
- 4) Press **+ -** switch ⑲ to change the set value.
- 5) Press switch **confirm** ⑳ to confirm the set value.

Example) To change the setting No. P-01 "the maximum number of revolutions":

Press switch **M** ⑱ to change over to the setting number display.

Press **+ -** switch ⑲ to select setting number P-01. Press switch **confirm** ⑳ to confirm the number. The current set value (maximum number of revolutions) of function setting number P-01 is displayed.

Change the maximum number of revolutions with **+ -** switch ⑲ and confirm the set value.

Then, confirm the setting with switch **confirm** ⑳.



## 5. Digital types operation

### (1) Comparison Table of LCD Display Fonts and Actual Fonts

Arabic Numerals :

Actual	0	1	2	3	4	5	6	7	8	9
Display	<i>0</i>	<i>1</i>	<i>2</i>	<i>3</i>	<i>4</i>	<i>5</i>	<i>6</i>	<i>7</i>	<i>8</i>	<i>9</i>





































### (2) Digital Display on the Key Board



























English Alphabet

Actual	A	B	C	D	E	F	G	H	I	J	K	L	M
Display	<i>A</i>	<i>b</i>	<i>C</i>	<i>d</i>	<i>E</i>	<i>F</i>	<i>G</i>	<i>H</i>	<i>,</i>	<i>J</i>	<i>k</i>	<i>L</i>	<i>M</i>
Actual	N	O	P	Q	R	S	T	U	V	W	X	Y	Z
Display	<i>n</i>	<i>o</i>	<i>P</i>	<i>q</i>	<i>r</i>	<i>S</i>	<i>T</i>	<i>U</i>	<i>v</i>	<i>W</i>	<i>X</i>	<i>Y</i>	<i>Z</i>

## 6. User Parameter & Technician Parameter

Parameter code	Parameter function	Range/ unit	Default	Key	Description
P01	Maximum sewing speed (sti/min)	100 to 4000	3500	<b>+</b> <b>-</b>	Maximum speed of machine sewing
P02	Speed curve adjustment(%)	1 to 100%	80	<b>+</b> <b>-</b>	The larger the value, the faster to increase speed
p03	Needle UP/ DOWN	uP / DN	DN	<b>+</b> <b>-</b>	Up: Needle stops at up position Dn: Needle stops at down position
p04	Start back-tacking speed (sti/min)	200 to 3200	1900	<b>+</b> <b>-</b>	Start Back-Tacking speed adjustment
P05	End back-tacking speed (sti/min)	200 to 3200	1900	<b>+</b> <b>-</b>	End Back-Tacking speed adjustment
P06	Bar-tacking speed (sti/min)	200 to 3200	1900	<b>+</b> <b>-</b>	Repeat Bar-Tacking speed adjustment
P07	Soft start speed (sti/min)	200 to 1500	800	<b>+</b> <b>-</b>	Soft Start speed adjustment
P08	Stitch numbers for soft start(sls)	0 to 99 Stitches	4	<b>+</b> <b>-</b>	Soft Start stitches setting (one unit = half stitch)
P09	Automatic constant-stitch sewing speed (sti/min)	200 to 4000	3500	<b>+</b> <b>-</b>	Constant-Stitch sewing speed [034.SMP] is set at A(or when one shot signal is active)
P10	Automatic end back-tacking sewing(can invalidate the stitch correction function)	ON / OFF	ON	<b>+</b> <b>-</b>	The Stitch-Correction is valid in sewing stop. Note : Valid only when the <b>[0.11.RVM]</b> must set on B ON : Invalid (Constant-Stitch sewing, it can automatic continue action as CD function) OFF : Valid (Can't continue execute CD function)

Parameter code	Parameter function	Range/ unit	Default	Key	Description
P11	Back-Tacking mode selection	J / B	J	 	Press Back-Tacking switch by hand: J : It will activate when machine is stopped or running B : It will activate only the machine is running
P12	Start Back-Tacking mode selection	A / M	A	 	Start Back-Tacking, reverse solenoid action: A : One shot to pedal, it will automatic execute Start Back-Tacking. M : Pedal-controlled and motor can stop arbitrarily
P13	Mode selection at the end of Start Back-Tacking	CON / STP	CON	 	CON :At the end of Start Back-Tacking, machine continues sewing if pedal pressed or START signal on ( standing operation) STP : At the end of Start Back-Tacking, machine stops
P14	Soft start	ON / OFF	ON	 	Add with full-function operation panel is valid. ON : Soft start function is turn on. OFF: Soft start function is turn off.
P15	Setting stitches A of Start Back-Tacking	1 to 15 Stitches	Reserve	 	Invalid,setting by front shortcut key
P16	Setting stitches B of Start Back-Tacking	1 to 15 Stitches	Reserve	 	Invalid,setting by front shortcut key
P17	Setting turns of Start Back-Tacking	1 to 4 Times	Reserve	 	Invalid,setting by front shortcut key
P18	Stitch balance for Start Back-Tacking 1	0 to 31	6	 	① 0→15 The action gradually delay ② 16→31 The action gradually advance ③ The action of 0 delay than 16
P19	Stitch balance for Start Back-Tacking 2	0 to 31	9	 	
P20	Mode selection for End Back-Tacking	A/M	M	 	End Back-Tacking, reverse solenoid action: A : Pedal full heeling ,it will automatic execute end Back-Tacking M : Pedal-controlled and motor can stop arbitrarily
P21	End Back-Tacking function selection	ON / OFF	Reserve	 	Invalid,setting by front shortcut key
P22	Setting stitches C of End Back-Tacking	1 to 15 Stitches	Reserve	 	Invalid,setting by front shortcut key
P23	Setting stitches D of End Back-Tacking	1 to 15 Stitches	Reserve	 	Invalid,setting by front shortcut key
P24	Setting turns of End Back-Tacking	1 to 4 Times	Reserve	 	Invalid,setting by front shortcut key
P25	Stitch balance for End Back-Tacking 3	0 to 31	12	 	① 0→15 The action gradually delay ② 16→31 The action gradually advance ③ The action of 0 delay than 16
P26	Stitch balance for End Back-Tacking 4		12	 	
P27	Adding 1 stitch to C segment of End Back-Tacking	ON / OFF	ON	 	Adding 1 Stitch to C Segment of End Back-Tacking ON : Valid OFF : Invalid
P28	Mode selection for Bar-Tacking	A/M	A	 	Bar-Tacking, reverse solenoid action: A : One shot to pedal, it will automatic execute Bar-Tacking. M : Pedal-controlled and motor can stop arbitrarily

Parameter code	Parameter function	Range/ unit	Default	Key	Description
P29	Bar-Tacking function Selection	ON / OFF	Reserve	 	Invalid,setting by front shortcut key
P30	Setting stitches of Bar-Tacking	1 to 99 Stitches	Reserve	 	Invalid,setting by front shortcut key
P31	Setting turns of Bar-Tacking	1 to 15 Stitches	Reserve	 	Invalid,setting by front shortcut key
P32	Stitch balance for Bar-Tacking 5	0 to 31	12	 	① 0→15 The action gradually delay ② 16→31 The action gradually advance ③ The action of 0 delay than 16
P33	Stitch Balance for Bar-Tacking 6	0 to 31	12	 	
P34	Mode selection for Constant-Stitch sewing	A / M	M	 	A : One shot to pedal, it will automatic execute Constant-Stitch M : Pedal-controlled and motor can stop arbitrarily
P35	Constant-Stitch sewing function selection	ON / OFF	Reserve	 	Invalid,setting by front shortcut key
P36	Setting stitches for section P1 of Constant-Stitch Sewing	1 to 250 Stitches	Reserve	 	Invalid,setting by front shortcut key
P37	Wiper function Selection or thread clamp pressure setting	0 to -11	1	 	0 : No Action 1 : Wiper Action 2-11 : Thread Clamp action and the pressure gradually increased)
P38	Trimmer function selection	ON / OFF	ON	 	ON : Trimmer Valid OFF : Trimmer Invalid
P39	Presser foot UP / Down at intermediate stop	UP / DN	DN	 	UP : Presser foot goes up automatically DN : Presser foot keeps down (Controlled by heeling pedal)
P40	Presser Foot UP / Down after trimming	UP / DN	DN	 	UP : Presser foot goes up automatically DN : Presser foot keeps down (Controlled by heeling pedal)
P41	Display the sewing finished quantity	0 to 9999	0	 	Counting the finished-sewing quantity
P42	Sewing speed display		0		Displaying the current sewing speed (the speed only for reference)
P43	Setting direction of motor rotation	CW / CCW	CCW		CW : Clockwise CCW : Counter Clockwise (Viewed from motor shaft side)

## 7. Details of setting of the main functions



1. In following parameter operation  $\oplus$   $\ominus$  key, it will display corresponding speed value.
2. In following function, after value changed, press  $\boxed{\leftarrow}$  key to save the value, otherwise they will lost after turning power off.

### (1) How to set [Maximum Sewing Speed]

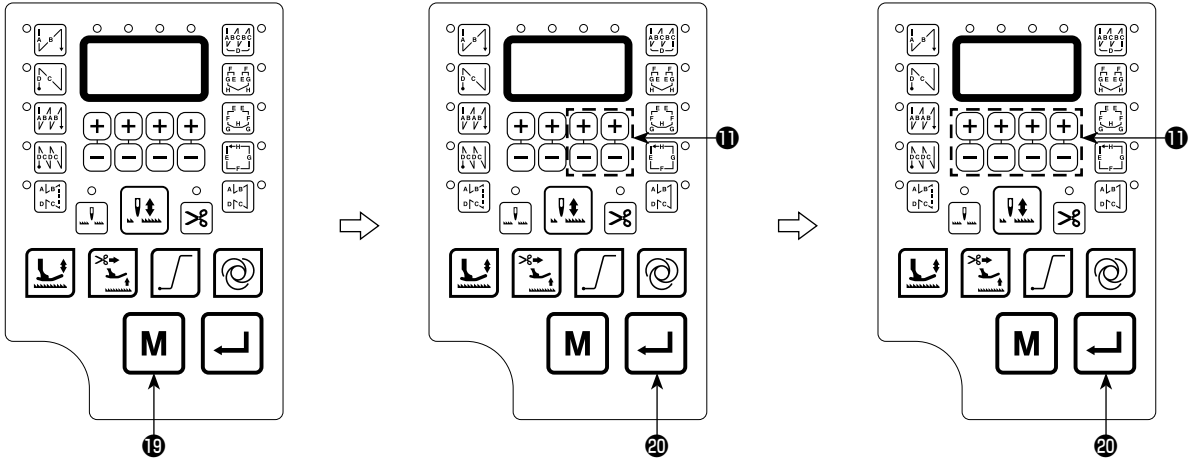

Press  $\boxed{M}$  Key ⑱ to enter Technician Parameter

Press  $\oplus$  or  $\ominus$  key ⑪ to get parameter code P01 press  $\boxed{\leftarrow}$  ⑳ to enter [parameter value]

- ① Press  $\oplus$ ,  $\ominus$  key ⑪ to adjust the Maximum Sewing Speed
- ② After adjustment press  $\boxed{\leftarrow}$  key ⑳ to save value.

### (2) How to set [Start Back-Tacking Speed]

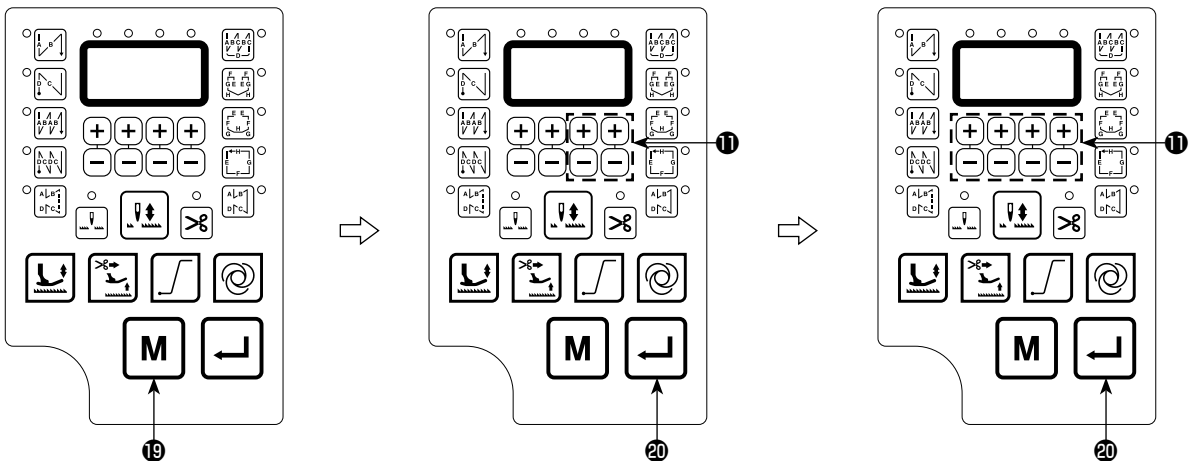

Press  $\boxed{M}$  Key ⑱ to enter Technician Parameter

Press  $\oplus$  or  $\ominus$  key ⑪ to get parameter code P04 press  $\boxed{\leftarrow}$  ⑳ to enter [parameter value]

- ① Press  $\oplus$ ,  $\ominus$  ⑪ key to adjust the Start Back-Tacking Speed
- ② After adjustment press  $\boxed{\leftarrow}$  key ⑳ to save value.

### (3) How to set [End Back-Tacking Speed]

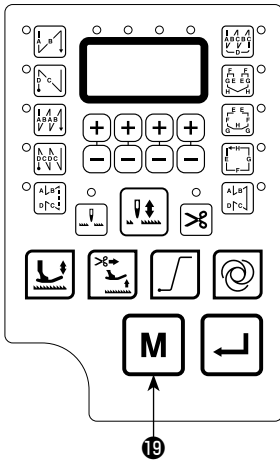

Press **M** Key 19 to enter Technician Parameter

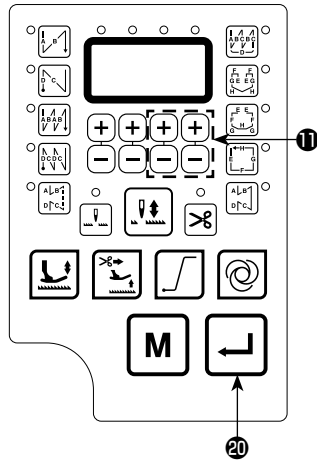

Press **+** or **-** key 20 to get parameter code P05 press **↵** key 20 to enter [parameter value]

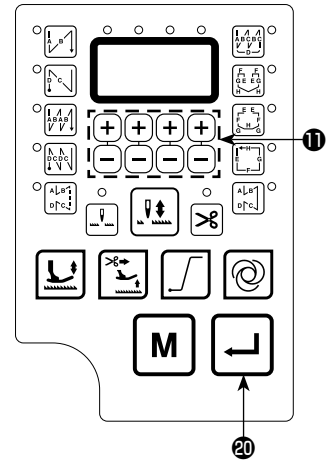

① Press **+**, **-** key 20 to adjust End Back-Tacking speed  
② After adjustment press **↵** key 20 to save value.

### (4) How to set [Bar-Tacking Speed]

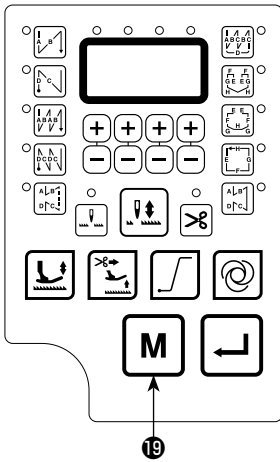

Press **M** Key 19 to enter Technician Parameter

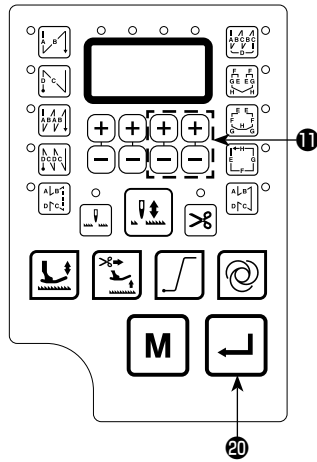

Press **+** or **-** key 20 to get parameter code P06 press **↵** key 20 to enter [parameter value]

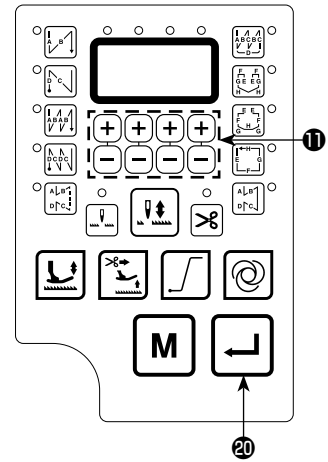

① Press **+**, **-** key 20 to adjust the Bar-Tacking Speed  
② After adjustment press **↵** key 20 to save value.

### (5) How to set [Constant-Stitch Sewing Speed]

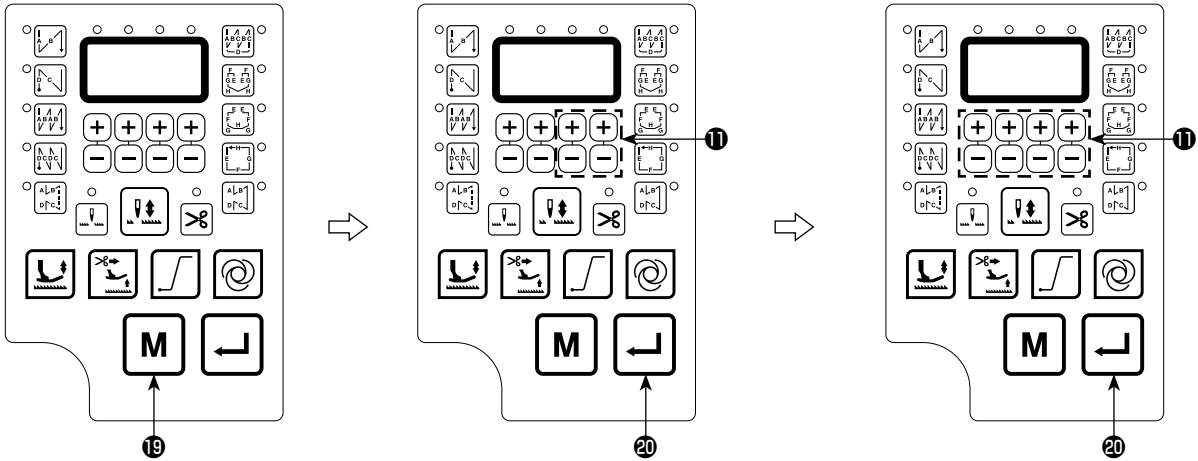

Press **M** Key ⑱ to enter Technician Parameter

Press **+** or **-** key ① to get parameter code P09 press **↵** ⑳ to enter [parameter value]

① Press **+**, **-** key ① to adjust Constant-Stitch Sewing speed  
② After adjustment press **↵** key ⑳ to save value.

### (6) How to adjust [Acceleration Factor] of Straight Sewing

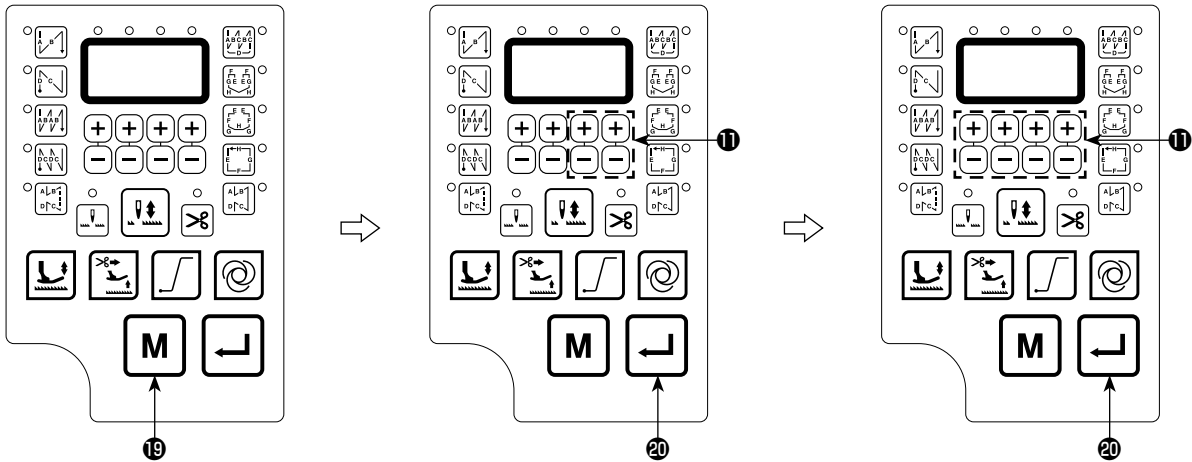

Press **M** Key ⑱ to enter Technician Parameter

Press **+** or **-** key ① to get parameter code P02 press **↵** ⑳ to enter [parameter value]

① Press **+**, **-** key ① to adjust Acceleration Factor  
② After adjustment press **↵** key ⑳ to save value.  
• if adjust value too low, it will influence the max. speed.

The relation between acceleration curve slope PSL setting value and maximum sewing speed:  
Each machine head to the parameter [001.H] maximum sewing speed's requirement is different, so setting PSL slope of curve in below ☆ symbol it will influence the maximum speed.

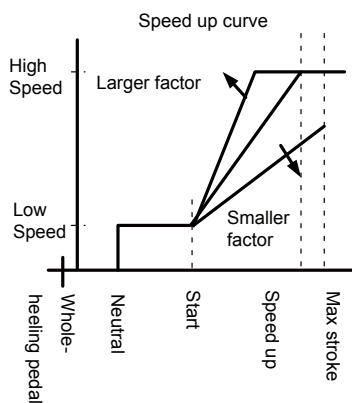

PSL	Acceleration factor for Max. speed									
	10%	20%	30%	40%	50%	60%	70%	80%	90%	100%
High Speed										
1000				☆						
2000						☆				
3000							☆			
4000								☆		

※ If can not get Max. Speed with improper adjustment

## 8. Stitch balance of back-tacking for lockstitch machine

### (1) How to balance stitches for [Start Back-Tacking]



Factory defaults of balance stitches for P-18.BT1 and P-19.BT2 are different because of different types of machine head.

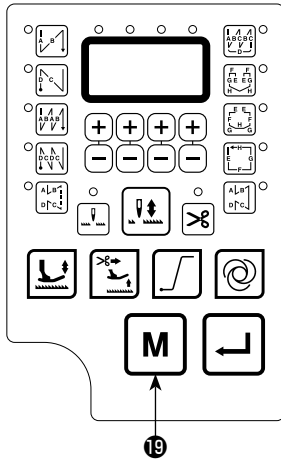

19

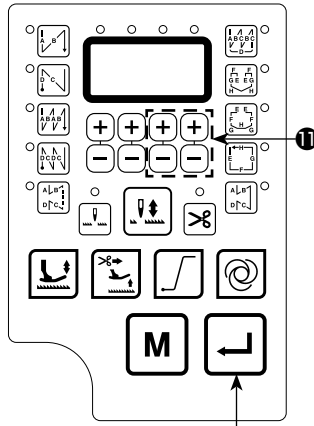

20

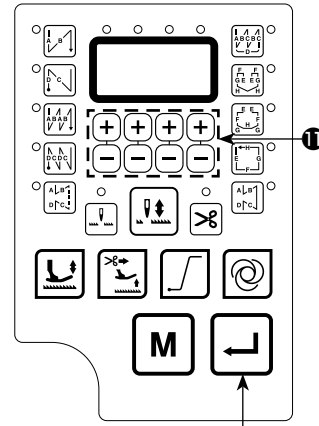

20

Press **M** Key 19 to enter Technician Parameter

Press **+** or **-** key 11 to get parameter code P-18, P-19 press **↵** 20 to enter [parameter value]

1 Press **+**, **-** key 11 to adjust P-18, P-19 balance stitches properly  
2 After adjustment press **↵** key 20 to save value.

Example : Step 1: Setting stitch number for Start Back-Tacking A and B=3

Step 2: Sewing the pattern in normal speed

Step 3: If unbalanced situation is appeared please correct it as below:

Suggestion: Select the balance stitches for Section A before selecting for B

Start point - - -

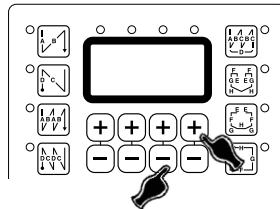
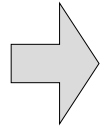
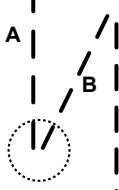

Case 1 : Longer A and shorter B  
Adjustment : Please adjust [P-18. BT1] value suitably.  
15 ⇒ 14 ⇒ . . . 1 ⇒ 0 ⇒ 16 ⇒ 17 ⇒ . . .  
⇒ 30 ⇒ 31

Start point - - -

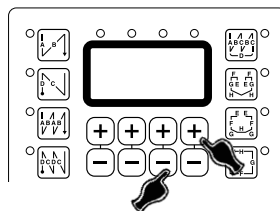
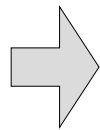
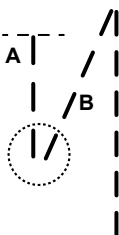

Case 2 : Shorter A and normal B  
Adjustment : Please adjust [P-18. BT1] value suitably.  
31 □ 30 □ □ □ □ 17 □ 16 □ 0 □ 1 □ □ □ □ □ 14 □ 15

Start point - - -

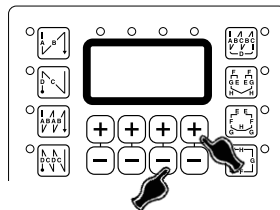
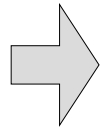

Case 3 : Normal A and longer B  
Adjustment : Please adjust [P-19. BT2] value suitably.  
15 ⇒ 14 ⇒ . . . ⇒ 1 ⇒ 0 ⇒ 16 ⇒ 17 ⇒ . . .  
⇒ 30 ⇒ 31

Start point - - -

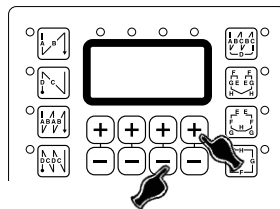
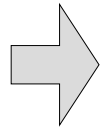
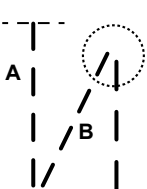

Case 4 : Normal A and shorter B  
Adjustment : Please adjust [P-19. BT2] value suitably.  
31 □ 30 □ □ □ □ 17 □ 16 □ 0 □ 1 □ □ □ □ □ 14 □ 15

## (2) How to balance stitches for [End Back-Tacking]

 Factory defaults of balance stitches for P-25.BT3 and P-26.BT4 are different because of different types of machine head.

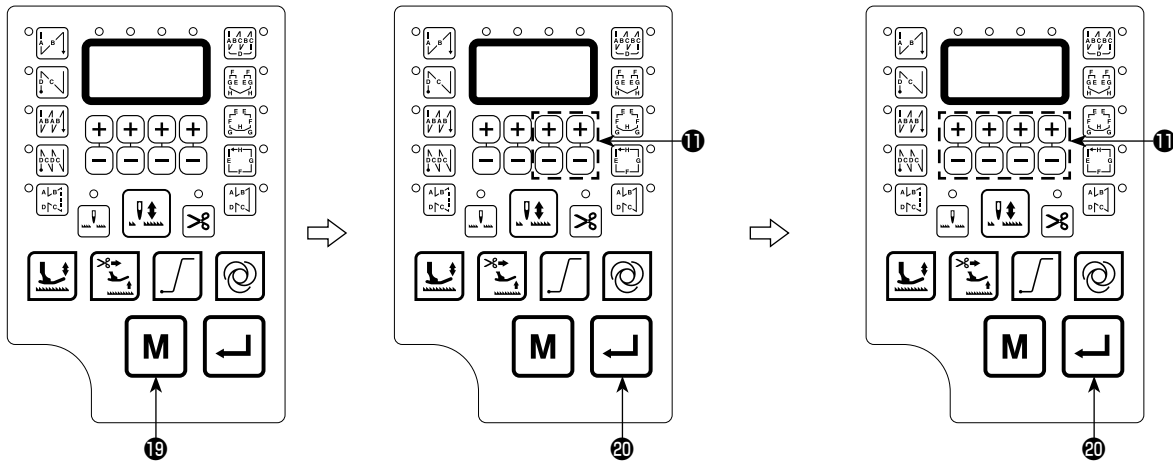

Press **M** Key 19 to enter Technician Parameter

Press **+** or **-** key 11 to get parameter code P-25, P-26 press **←** 20 to enter [parameter value]

① Press **+**, **-** key 11 to adjust P-25, P-26 balance stitches properly  
② After adjustment press **←** key 20 to save value.

Example : Step 1: Setting stitch number for End Back-Tacking C and D=3  
Step 2: Sewing the pattern in normal speed  
Step 3: If unbalanced situation is appeared please correct it as below:  
Suggestion: Select the balance stitches for Section C before selecting for D

<p>Start point</p>		<p>Case 1 : Longer C and shorter D Adjustment : Please adjust [P-25. BT3] value suitably. 15 ⇒ 14 ⇒ . . . 1 ⇒ 0 ⇒ 16 ⇒ 17 ⇒ . . . ⇒ 30 ⇒ 31</p>
<p>Start point</p>		<p>Case 2 : Shorter C and normal D Adjustment : Please adjust [P-25. BT3] value suitably. 31 □ 30 □ □ □ □ □ 17 □ 16 □ 0 □ 1 □ □ □ □ □ 14 □ 15</p>
<p>Start point</p>		<p>Case 3 : Normal C and longer D Adjustment : Please adjust [P-26. BT4] value suitably. 31 □ 30 □ □ □ □ □ 17 □ 16 □ 0 □ 1 □ □ □ □ □ 14 □ 15</p>
<p>Start point</p>		<p>Case 4 : Normal C and shorter D Adjustment : Please adjust [P-26. BT4] value suitably. 15 ⇒ 14 ⇒ . . . 1 ⇒ 0 ⇒ 16 ⇒ 17 ⇒ . . . ⇒ 30 ⇒ 31</p>



### (3) How to balance stitches for [Bar Tacking]

 Factory defaults of balance stitches for P-32.BT5 and P-33.BT6 are different because of different types of machine head.

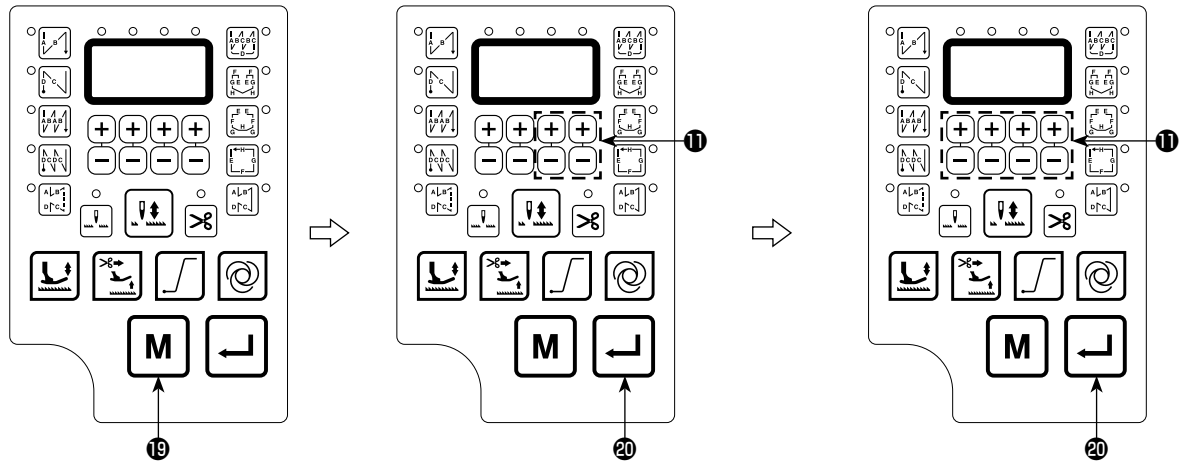

Press **M** Key ⑱ to enter Technician Parameter

Press **+** or **-** key ① to get parameter code P-32, P-33 press **↵** ⑳ to enter [parameter value]

① Press **+**, **-** key ① to adjust P-32, P-33 balance stitches properly  
② After adjustment press **↵** key ⑳ to save value.

Example : Step 1 : Setting stitch number for Bar-Tacking A=B= 4 and turns of Bar-Tacking D=4  
Step 2 : Sewing the pattern in normal speed  
Step 3 : If unbalanced situation is appeared please correct it as below:

Suggestion : Select the balance stitches for Section A(1.3) before selecting for B(2.4)

<p>Start point</p>		<p>Case 1 : Longer A and shorter B Adjustment : Please adjust [P-32. BT5] value suitably. 15 ⇒ 14 ⇒ . . . 1 ⇒ 0 ⇒ 16 ⇒ 17 ⇒ . . . ⇒ 30 ⇒ 31</p>
<p>Start point</p>		<p>Case 2 : Shorter A and normal B Adjustment : Please adjust [P-32. BT5] value suitably. 31 ⇒ 30 ⇒ . . . 17 ⇒ 16 ⇒ 0 ⇒ 1 ⇒ . . . ⇒ 14 ⇒ 15</p>
<p>Start point</p>		<p>Case 3 : Normal A and longer B Adjustment : Please adjust [P-33. BT6] value suitably. 15 ⇒ 14 . . . ⇒ 1 ⇒ 0 ⇒ 16 ⇒ 17 ⇒ . . . ⇒ 30 ⇒ 31</p>
<p>Start point</p>		<p>Case 4 : Normal A and shorter B Adjustment : Please adjust [P-33. BT6] value suitably. 31 ⇒ 30 ⇒ . . . 17 ⇒ 16 ⇒ 0 ⇒ 1 ⇒ . . . ⇒ 14 ⇒ 15</p>

## 9. Error code list

Error Code	Problem	STATUS / MEASUREMENT
E1	Power Module is faulty. Abnormal over current or voltage. Resistor is damaged or F1 fuse is blown.	System will be shut down until the power resets on. Please check the power board in detail.
E2	1) When power on, detected main voltage too low 2) Connect the wrong voltage, too low.	Motor and machine will be shutting down. Please check the AC power. (Too low) Please check the main pc board.
E3	Operation Box linked to CPU interface had communication error.	Motor and machine will be shutting down. Please check the operation box.
E5	Faulty connection of the pedal sensor	Check whether the pedal sensor connector is securely connected.
E7	a) Bad connection at the motor connector. b) Synchronizer signal error c) Machine locked or object stuck in the motor pulley. d) Sewing material is too thick. e) Module output is abnormal.	System will be shut down until the power resets on. Please check the motor connectors, synchronizer situation and machine situation.
E8	Manual Back-Tacking lasts for 15 sec.	System will be shut down until the power resets on.
E9	Synchronizer signal error.	Please check the positioning signal or the condition of pulley.
E11	Auto Needle Up is malfunction as power on.	Motor still can run, but it automatically starts the clutch mode. All constant-stitch sewing pattern and trimmer / wiper function is invalid. Please check the synchronizer.
E12	Power is turned on without the synchronizer signal.	Motor still can run, but it automatically starts the clutch mode. All constant-stitch sewing pattern and trimmer / wiper function is invalid. Please check the synchronizer.
E13	Overheat Protection f or Power Module	Please check the connection between power module and heat sink.
E14	Encoder signal error.	Please check the encoder signal or change the encoder.
E15	Abnormal over current protection for Power Module.	System will be shut down until the power resets on. Please check the power board in detail.
E16	Trimmer switch error.	Please check the trimmer switch whether turn in the correct position.
E17	Machine head switch error.	Please check if the machine head whether raised or if the machine head switch is damaged.