

ENGLISH

**Knee-lifter device
INSTRUCTION MANUAL**

CONTENS

1. Knee-lifter asm. for the DDL-8000A (part number: 40217286).....	1
1-1. Contents of parts supplied with the knee-lifter asm.	1
1-2. Assembling procedure	2

Congratulations on your purchase of the parts for JUKI industrial sewing machine. Be sure to carefully read "Safety precautions" and the Instruction Manual for the model of your sewing machine.

1. Knee-lifter asm. for the DDL-8000A (part number: 40217286)

This is the optional device to be attached to the DDL-8000A sewing machine. This device can be used in conjunction with the motor-driven presser foot lifting device and is used to allow the operator to lift the presser foot by operating the device with the operator's knee.

1-1. Contents of parts supplied with the knee-lifter asm.

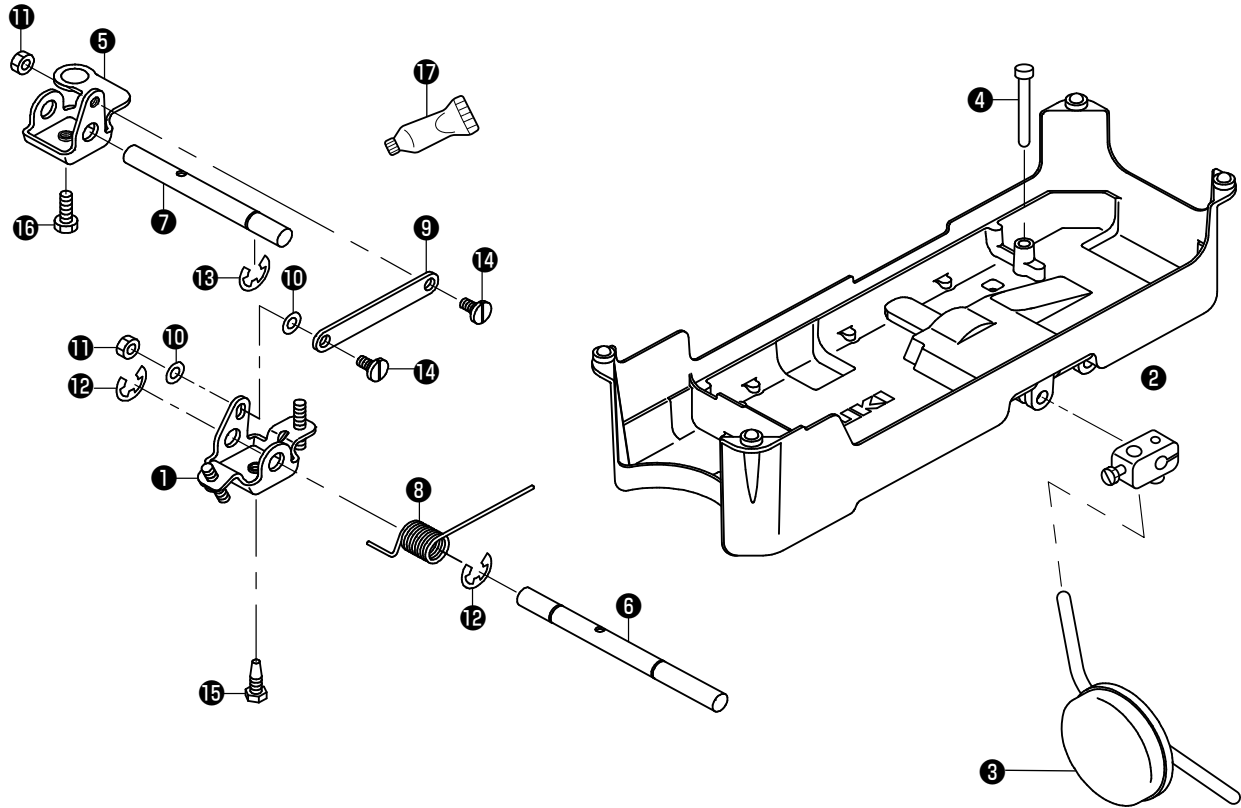

No.	Part number	Part name	Quantity
①	23639156	Knee-lifter rotation arm (asm.)	1
②	22932453	Knee-pad vertical shaft mounting arm (asm.)	1
③	22934251	Knee-pad plate (asm.)	1
④	23639701	Knee-lifter push rod	1
⑤	23639206	Knee-lifter actuation arm	1
⑥	23639305	Knee-pad horizontal shaft	1
⑦	23639404	Knee-lifter operating shaft	1
⑧	23639503	Knee-lifter rotation arm spring	1
⑨	23639602	Knee-lifter connecting rod	1
⑩	WP0650876SD	Knee-lifter connecting rod washer	2
⑪	NS6150310SP	Knee-lifter connecting rod nut	2
⑫	RE1000000K0	Knee-pad horizontal shaft E ring	2
⑬	RE1000000K0	Knee-lifter operating shaft E ring	1
⑭	SD0720331SP	Knee-lifter connecting rod hinge screw	2
⑮	SM9061853SR	Knee-lifter rotation arm setscrew	1
⑯	SM9061853SR	Knee-lifter actuation arm setscrew	1
⑰	40006323	JUKI Grease A tube	1

1-2. Assembling procedure

- 1) Assemble knee-lifter rotation arm (asm.) ①, knee-lifter actuation arm ⑤ and knee-lifter connecting rod ⑨ with washers ⑩, nut ⑪ and hinge screw ⑭.

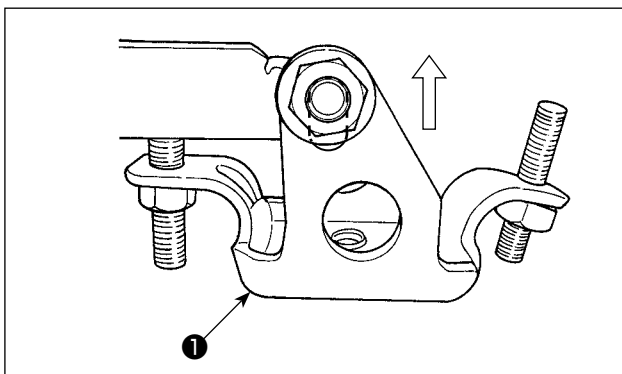
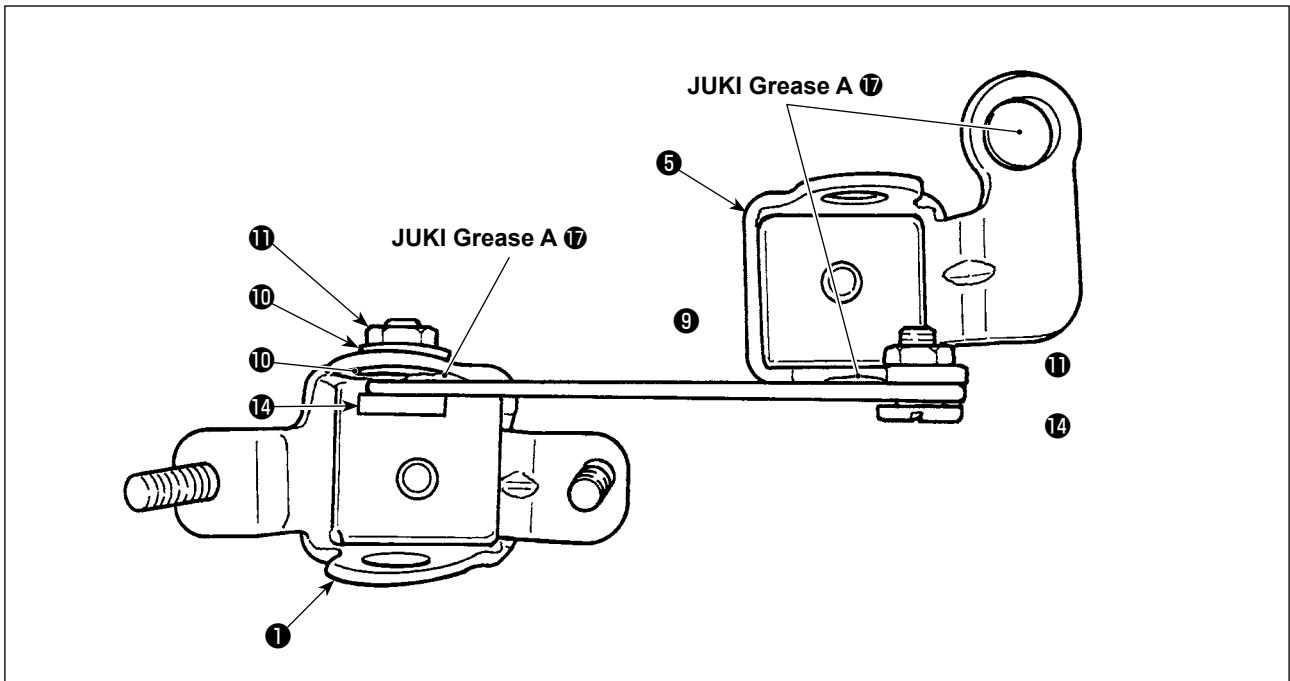

- 2) Secure the knee-lifter (asm.) in knee-lifter rotation arm (asm.) ① with screws.
 3) Apply JUKI Grease A ⑰ to the indicated portions (three locations).

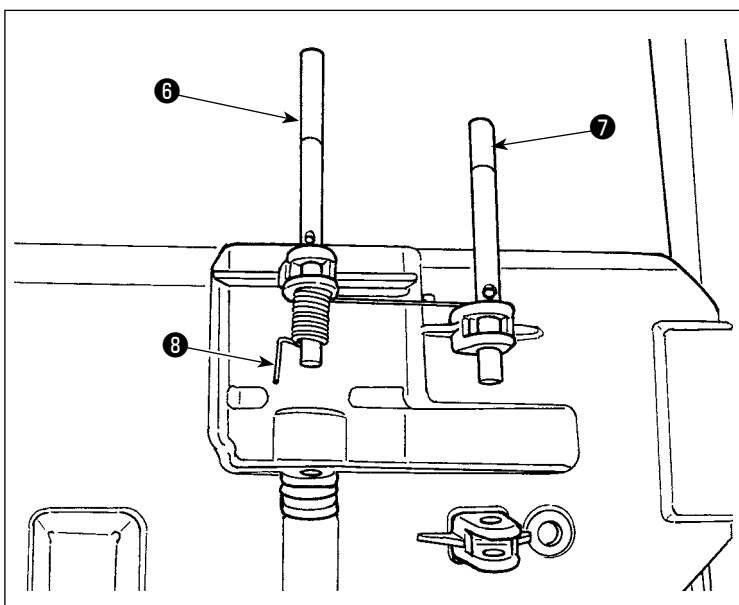

- 4) Insert knee-pad horizontal shaft ⑥, to which knee-lifter rotating arm spring ⑧ has been attached, and knee-lifter operating shaft ⑦ into under-cover B asm. (part number: 40062323).

Caution
 Carefully check the orientation of the spring and that of the shaft. (E-ring groove and the hole position)

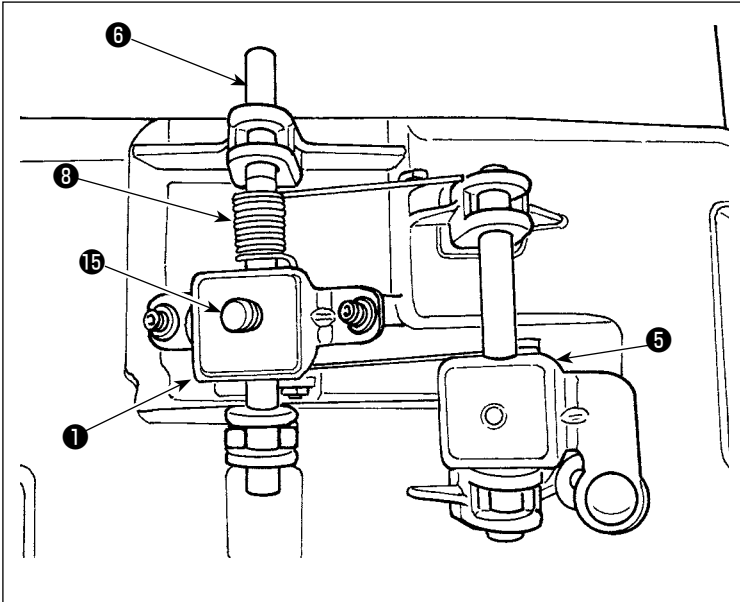

- 5) Pass knee-lifter rotation arm asm. ① and knee-lifter actuation arm ⑤ that have been assembled in 1) through the shaft.
- 6) Put the arm of knee-lifter rotation arm spring ⑧ on rotation arm (asm.) ① .
- 7) Insert knee-lifter rotation arm setscrew ⑮ into the hole in knee-pad horizontal shaft ⑥ and tighten the setscrew.

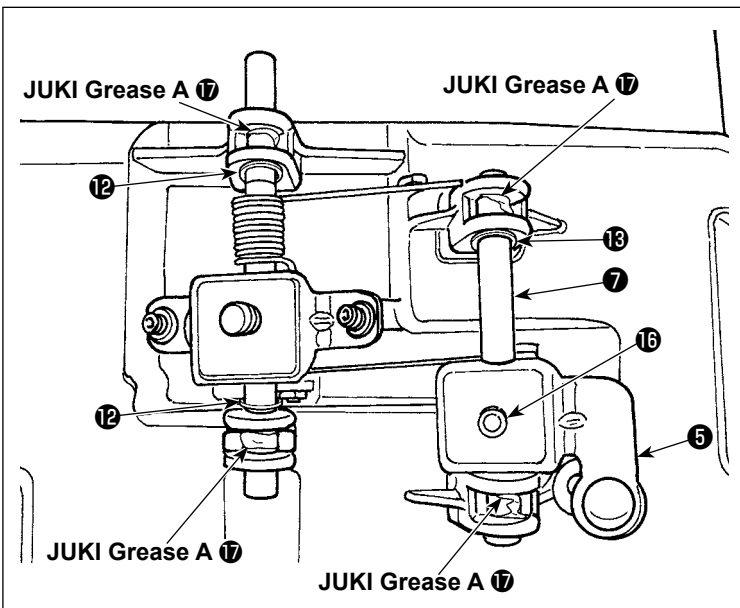

- 8) Insert knee-lifter actuation arm ⑤ and knee-lifter rotation arm setscrew ⑮ through the hole in knee-lifter operating shaft ⑦ and secure them. Secure knee-pad horizontal shaft ⑥ and knee-lifter operating shaft ⑦ with knee-pad horizontal shaft E rings ⑫ (two pieces) and knee-lifter operating shaft E ring ⑬ (one piece).

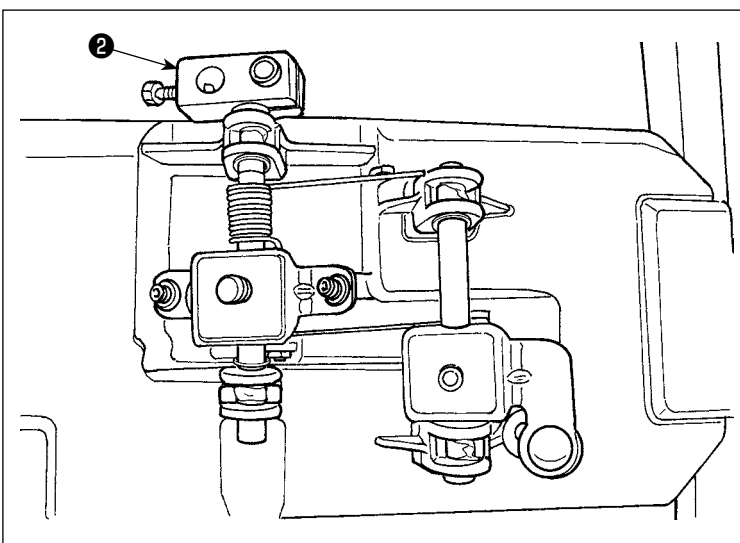

- 9) Secure knee-pad vertical shaft mounting arm (asm.) ② .

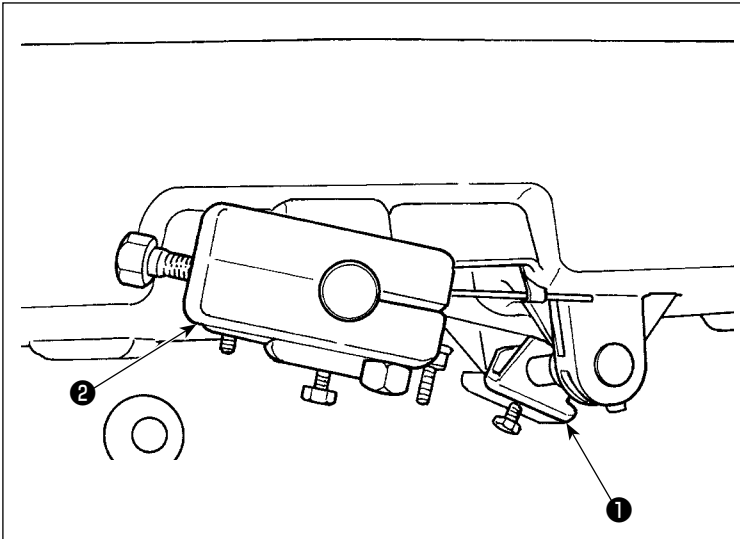

Adjust the inclination of knee-pad vertical shaft mounting arm (asm.) ② to the same inclination of knee-lifter rotation arm (asm.) ① . Then, secure the knee-pad vertical shaft mounting arm (asm.) ② .

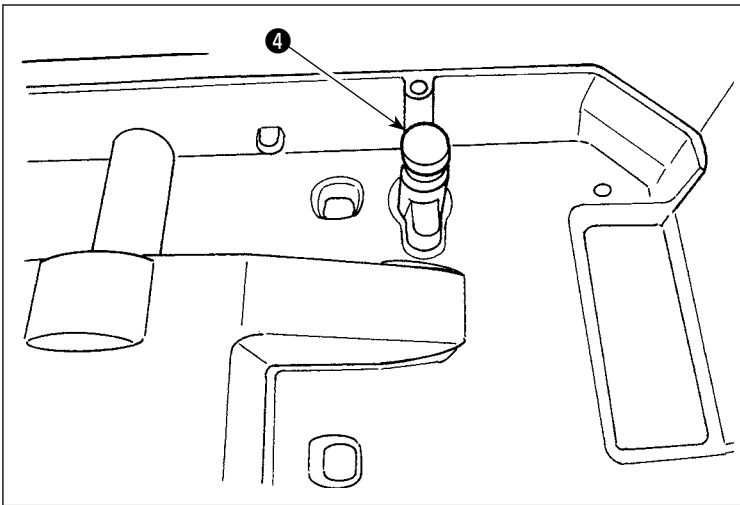

10) Attach the under-cover to the table.
Place knee-lifter push rod ④ to the table.

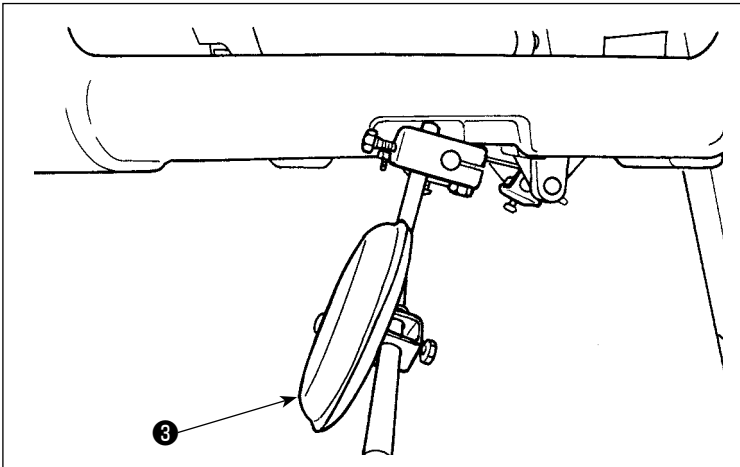

11) Secure knee-pad plate (asm.) ③ .

Push the knee-pad plate to confirm that the presser foot goes up.

