

# ***PARTS LIST***

**C-1A**

**零件表 /PARTS LIST**



# 目录 / INDEX

1. 机壳分组件 / MACHINE PRAME & MISCELLANEOUS COVER COMPONENTS.....	1
2. 上轴、挑线装置 / MAIN SHAFT&THREA DTAKE-UP COMPONENTS .....	3
3. 针杆、竖轴、下轴装置 / NEEDLE BAR UPRIGHT SHAFT&HOOK DRIVING SHAFT MECHANISM .	5
4. 压脚装置 / PRESSER FOOT MECHANISM .....	7
5. 送料装置 / FEED MECHANISM .....	9
6. 送料、调节分组件 / FEED REGULATING COMPONENTS.....	11
7. 切刀部件 / UPPER KNIFE MECHANIS .....	13
8. 剪线分组件 / THREAD TRIMMER COMPONENTS.....	15
9. 电子夹线组件 / ELECTRIC CLAMP COMPONENTS .....	17
10. 润滑装置 / OIL LUBICATION MECHANISM.....	19
11. 油盘装置 / OIL RESERVOIR MECHANISM.....	21
12. 附件 / ACCESSORIES .....	23
13. 自动抬压脚组件 / AUTOMATIC PRESSER FOOT LIFTER COMPONENTS .....	25
14. 针位零件一览表 / NEEDLE POSITION PARTS LIST.....	27

# 1. 机壳分组件 / MACHINE PRAME & MISCELLANEOUS COVER COMPONENTS

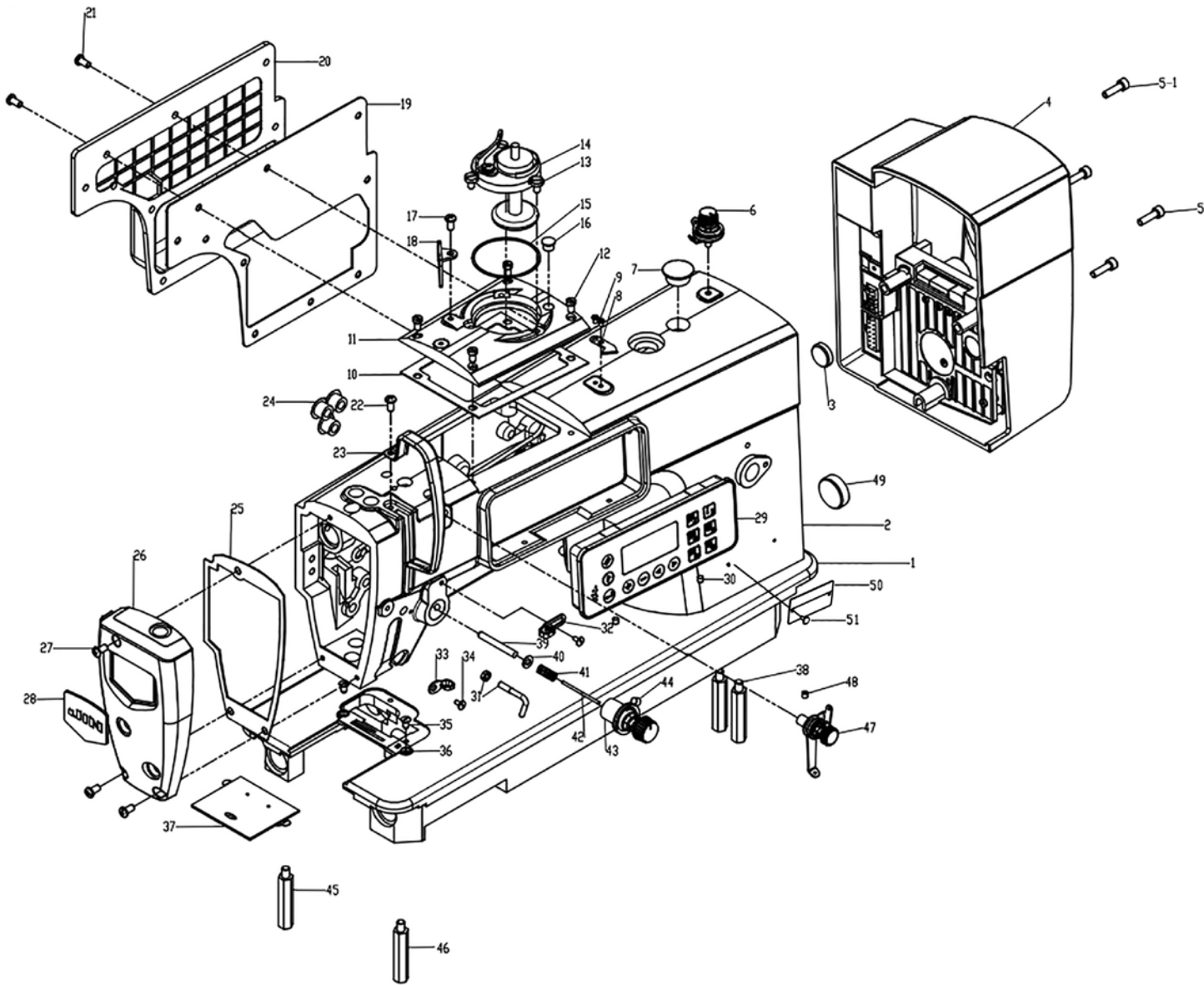

序号 Ref. No	件号 Part No	名称	Description	数量 QTY
1	JIN3400Q5070101	底板	Bed	1
2	JIN330C1A020101	机头	Arm	1
3	JINPF5550114	橡皮塞Φ19	Rubber, phug(Φ19)	1
4	JINPFC1A0144	电机罩	Motor cover	1
5	JINPF55T0145	螺钉M4*35	Screw M4*35	3
5-1	JINPF55T0149	螺钉M4*25	Screw M4*25	1
6	JINPFQ514101	绕线夹线器组件	BOBBIN THREAD TENSION ASM	1
7	JINPF98000187	调节孔孔塞	RUBBER PLUG	1
8	JINPF90000132	切刀	CUTTER	1
9	JINPF68425K19	螺钉1/8*40-4	Screw 1/8*40-4	2
10	JINPFC10109	上盖垫片	The upper cover gasket	1
11	JINPFC10110L	上盖	loam cake	1
12	JINPF6150812	螺钉	Screw	4
13	JINPF90000131	卷线器固定螺钉	Screw	3
14	JINPF55T014201	卷线器组件	Reel Components	1
15	JINPF900001511	绕线器垫片油封	Oil seal	1
16	JINPF5550112	孔塞	RUBBER PLUG	2
17	JINPF90008108	螺钉	Screw	1
18	JINPF0302113	三眼线勾	Over pole	1
19	JINPFC1A0114	后盖板垫片	Gasket for arm side cover	1
20	JINPFC1A0115	后盖板	Arm side cover	1
21	JINPF555016	螺钉	Screw	8
22	JINPF5550230	螺钉 3/16*28-6	Screw 3/16*28-6	1
23	JINPFQ90A0126L	挑线杆防护罩	Thread take-up guard	1
24	JINPF7810167	孔塞	Rubber plug	1
25	JINPFC10121	面板垫片	Gasket for face plate	1
26	JINPFC10122L	面板	faceplate	1
27	JINPF5550161	螺钉3/16*28-12	Screw 3/16*28-12	3
28	JINBZ3361	面板装饰牌	PLATE	1
29	JINPFC1A014401	操作面板	OPERATION PANEL	1
30	JINPF68425H33	螺丝	Screw	2
31	JINPF9520MXDK021	大线钩	Large arm thread guide	1
32	JINPF5550316	机壳线钩	Chassis line kook	1
33	JINPF5550318	左线钩	Left arm thread guide	1
34	JINPF5550317	线钩螺钉11/64*40-6	Screw 11/64*40-6	2
35	JINPF5550637	针板螺钉 11/64*40-8.5	Needle plate screw	2
36	JINPF852013502	针板	Slide plate	1
37	JINPF5550638	推板组件	Slide plate spring	1
38	JINPF555013	机壳支撑杆	Rod case	2
39	JINPF90000329	松线辅钉	Loose wire nails	1
40	JINPF5550333	松线辅钉垫片	TENSION RELEASE SUPPORTING PIN	1
41	JINPF5550334	松线辅钉弹簧	TENSION RELEASE PIN SPRING	1
42	JINPF6150131	松线钉	Thread RELEASE PIN	1
43	JINPFQ531726B	夹线器组件	Clamp components	1
44	JINPF5550330	螺钉 15/64*28-7	Screw 15/64*28-7	1
45	JINPF90000121	机壳支撑杆(中)	Rod case(M)	1
46	JINPF90000120	机壳支撑杆(长)	Rod case(L)	1
47	JINPFQ531216	小夹线器组件	Small clip cord assembly	1
48	JINPF68425H33	螺钉	Screw	1
49	JINPF5550115	下轴盲孔塞	RUBBER PLUG	1
50	JINPFBZ3514	型号牌	TYPE PLATE	1
51	JINSCJ6071	铆钉	RIVTE	2

## 2. 上轴、挑线装置 / MAIN SHAFT & THREAD TAKE-UP COMPONENTS

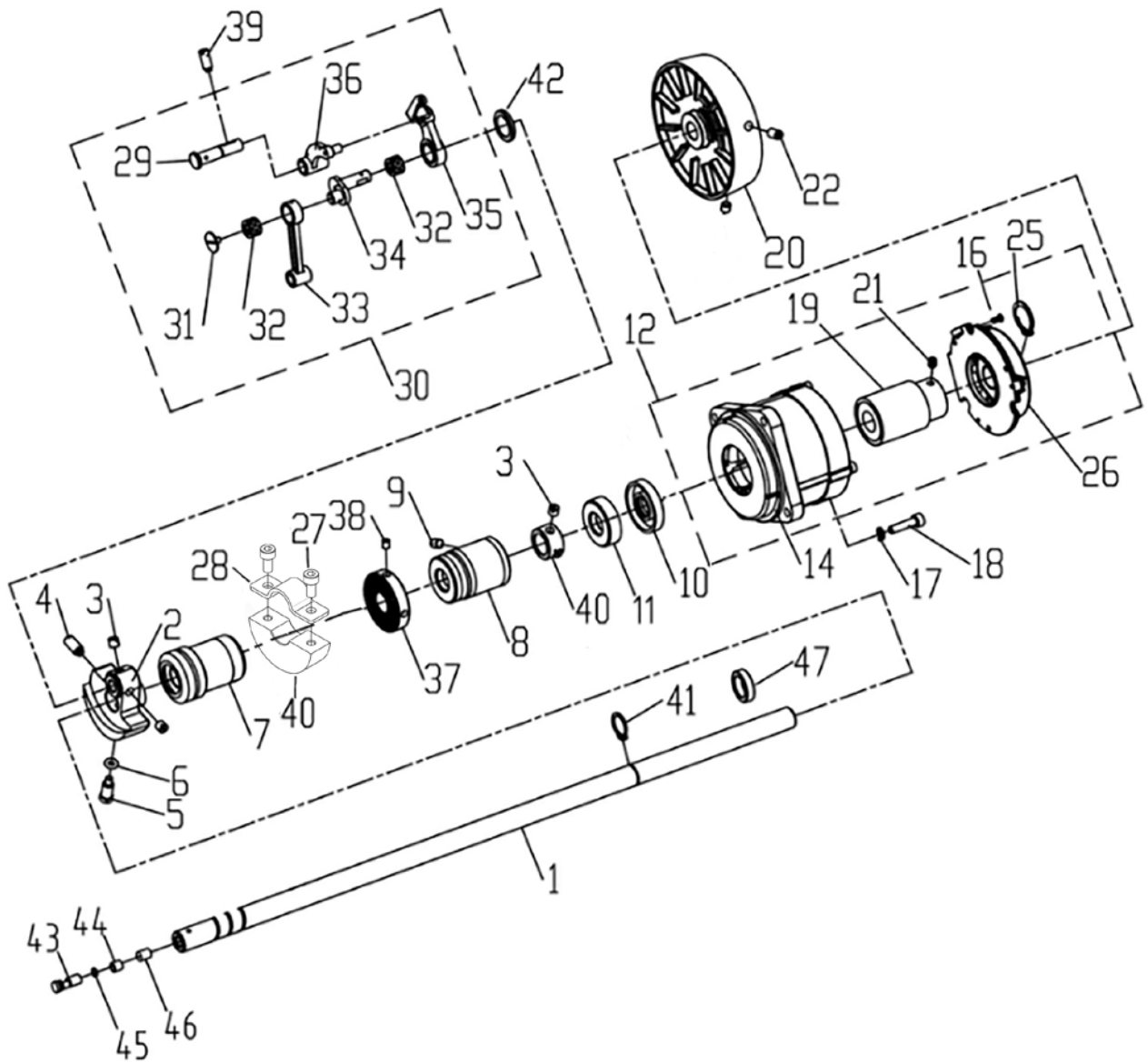

序号 Ref.No	件号 Part No	名称	Description	数量 QTY
1	JINPFC1A0201	上轴	MAIN SHAFT	1
2	JINPFQ60202	针杆曲柄	NEEDLE BAR CRANK	1
3	JINPF5550625	挑线曲柄定位螺钉	SCREW	4
4	JINPF5550218	针杆曲柄紧固螺钉	SCREW	1
5	JINPF5550216	针杆曲柄定位螺钉	SCREW	1
6	JINPF5550217	针杆曲柄定位螺钉O型圈	RUBBER RING	1
7	JINPF90000207	上轴前轴套	FRONT BUSHING OF MAIN SHAFT	1
8	JINPF555028	上轴中轴套	MID BUSHING OF MAIN SHAFT	1
9	JINPF555029	上轴中轴套螺钉	SCREW	1
10	JINPF90000210	上轴油封	OIL SEAL	1
11	JINPF9802DP0205	上轴后套	UPPER SHAFT REAR SLEEVE	1
12	JIN14100019	电机组件	MOTOR	1
14	JINPFQ5TE2014413	电机定子	MOTOR STATOR	1
16	JINPFS5T0216	紧固螺钉	SCREW	6
17	JINSCJ3008	弹簧垫片	WASHER	4
18	JINSCJ2010	上轴电机螺钉M5*45	SCREW	4
19	JINPFQ5TE2014414	电机转子	MOTOR ROTOR	1
20	JINPFS5T0220	上轮	HEAD WHEEL	1
21	JINPFS5T021205	转子固定螺钉	SCREW	2
22	JINPF1310B24	上轮螺钉	SCREW	2
25	JINPFS5T021208	卡簧	REED SPRING	1
26	JINPFQ5TE20144SF03	编码器组件	ENCODER COMPONENT	1
27	JINBF310164500	螺钉	SCREW	2
28	JINPF1900A0253	偏心盖板	ECCENTRIC COVER PLATE	1
29	JINPF5550225	挑线杆铰链轴	THREED TAKE-UP CRANK SHAFT	1
30	JINPF5550K0223A	挑线杆部件	THREED TAKE-UP ASM.	1
31	JINPF5550228	挑线曲柄左螺钉	SCREW	1
32	JINPF555022404	滚针轴承	BEARING	2
33	JINPF555031	针杆连杆	NEEDLE BAR CONNECTING ROD	1
34	JINPF55502201	挑线杆轴	THREED TAKE-UP SHAFT	1
35	JINPF55502212	挑线杆	THREED TAKE-UP	1
36	JINPF55502211	挑线杆连杆	THREED TAKE-UP CONNECTING ROD	1
37	JINPF90000237	绕线主动轮	WHEEL	1
38	JINPF68425M33	绕线主动轮紧定螺钉	SCREW	2
39	JINPF555022	挑线杆铰链轴紧固螺钉	SCREW	1
40	JINPFC10201	平衡块	Weight	1
41	JINSCJ1036	转子限位挡圈	RETAINING RING	1
42	JINPF900008134	垫圈(H)	WASHER (H)	1
43	JINPF5550213	上轴油量调节销	OIL AMOUNT ADJUSTING PIN	1
44	JINPF5550212	曲柄油量调节销	OIL ADJUSTING COLLAR	1
45	JINPF5550214	上轴油量调节销O型圈	RUBBER RING	1
46	JINPF5550211	曲柄油量限制毡	ROLLER FELT	1
47	JINPFQ5F0242	垫圈	WASHER	1

3. 针杆、竖轴、下轴装置 / NEEDLE BAR UPRIGHT SHAFT&HOOK DRIVING SHAFT MECHANISM

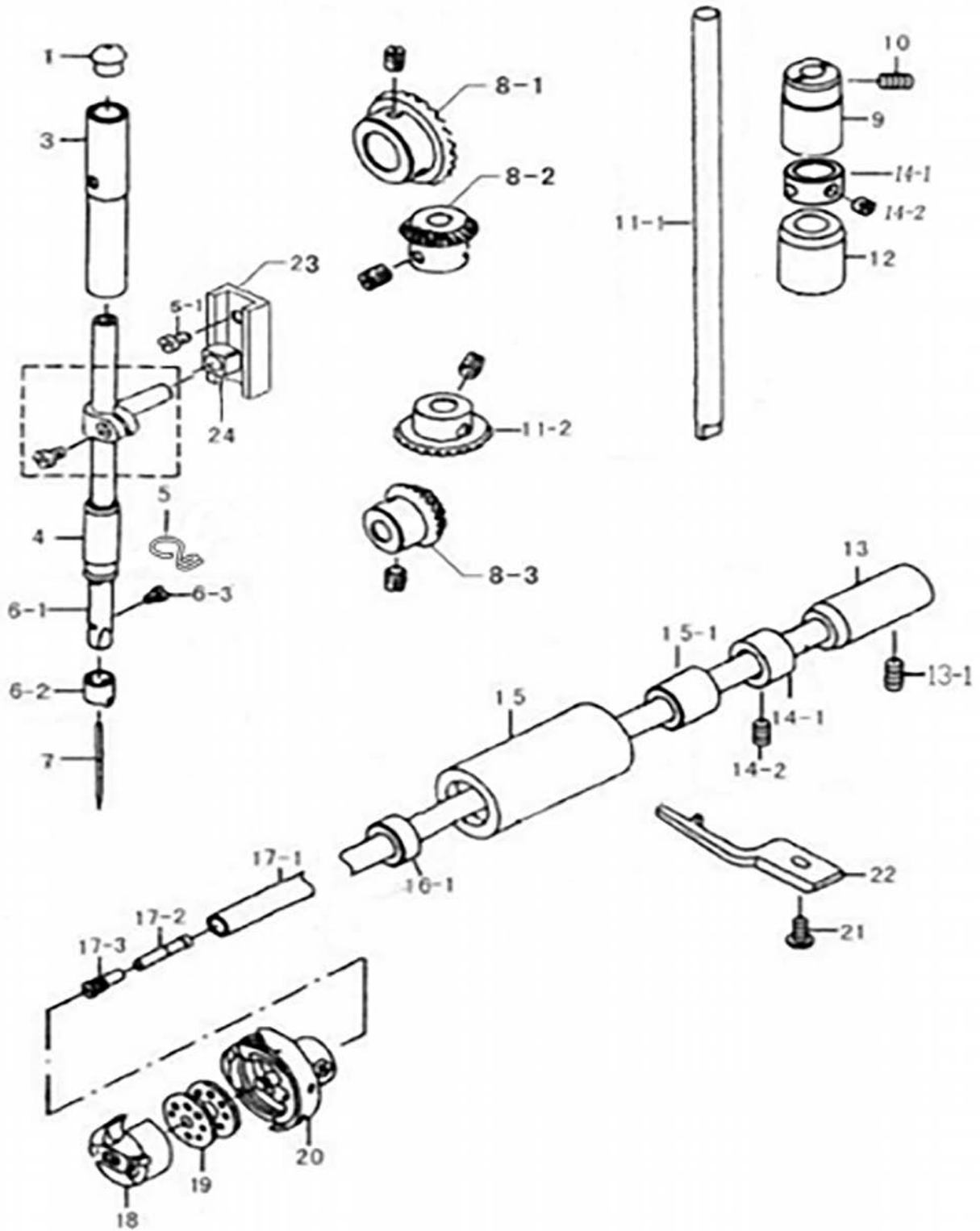



序号 Ref. No	件号 Part No	名称	Description	数量 QTY
1	JINPF555037	针针橡皮塞Φ8	Red, rubber-plug (Φ8)	1
3	JINPF555036	针杆上套	Needle bar bushing (upper)	1
4	JINPF90000306H	针杆下套	Needle bar bushing (lower)	1
5	JINPF5550H39	针杆下轴套线钩	Needle bar thread guide	1
5—1	JINPF6150227	螺钉	Screw	2
6—1	JINPF8520303	针杆	Needle bar	1
6—2	JINPF8520310	针杆过线勾-3	Thread guide for bushing (lower)	1
6—3	JINPF5550312	螺钉1/8*44-4.5	Screw 1/8*44-4.5	1
7	JINPFDTDB114	机针	Needle	1
8—1	JINPF555052605	伞齿轮组件	Bevel gear for vertical shaft assy	1
8—2	JINPF555052505	伞齿轮组件	Bevel gear for vertical shaft assy	1
8—3	JINPF555051805	伞齿轮组件	Bevel gear for vertical shaft assy	1
9	JINPF90000521	竖轴上轴套	Vertical shaft bushing (upper)	1
10	JINPF9800TD410	竖轴上套紧定螺钉	Screw 3/16*28-4	1
11—1	JINPF5550524	竖轴	Upring shaft	1
11—2	JINPF555052005	竖轴下伞齿轮	Bevel gear for vertical shaft (lower)	1
12	JINPF90000520	竖轴下轴套	Vertical shaft bushing (lower)	1
13	JINPF90000513	下轴后轴套	Hook shaft bushing (right)	1
13—1	JINPF555029	螺钉 15/64*28-8	Screw 15/64*28-8	1
14—1	JINPF6150404	下轴紧圈	Collar for hook shaft	1
14—2	JINPF55506261	螺钉15/64*28-7	Screw 15/64*28-7	2
15	JINPF90000510	下轴前轴套	Hook shaft bushing (left)	1
15—1	JINPF90000512	下轴中轴套	Mid bushing	1
16—1	JINPF9990709	下轴挡油圈	Oil under the ring gear shaft assembly	1
17—1	JINPFQ50507	下轴	Rotating hook shaft	1
17—2	JINPF55505901	下轴限油芯	Filter	1
17—3	JINPF555058	下轴限油螺钉	Filter Screw	1
18	JINPF888056D5202	梭心套(国产)	Bobbin case	1
19	JINPF555053	梭心	Bobbin	1
20	JINPF888056D50109	旋梭组件-3(国产)	Rotating hook Complete	1
21	JINBF700S039	螺钉11/64*40-9.5	Screw 11/64*40-9.5	1
22	JINPF555055	旋梭定位勾	Rotating hook positsnev	1
23	JINPF9001033101	针杆滑块槽组件	NEEDLE BAR TROUGH ASM.	1
24	JINPF90010311	滑块	Slide block	1

#### 4. 压脚装置 / PRESSER FOOT MECHANISM

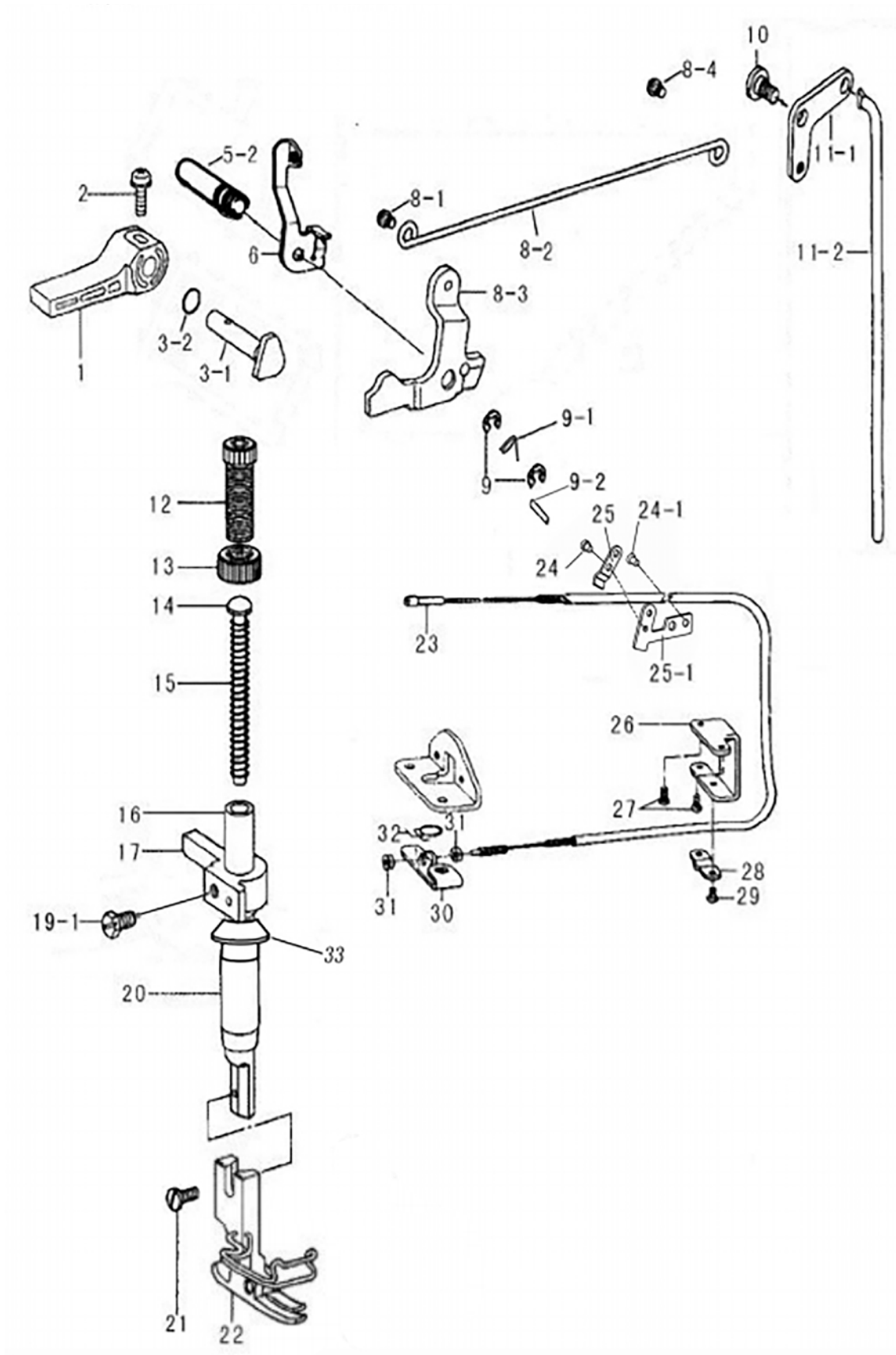

序号 Ref. No	件号 Part No	名称	Description	数量 QTY
1	JINPF8420M-D3051101	抬压脚扳手	Presser bar lifter	1
2	JINPF8420M-D30512	螺钉	Screw	1
3-1	JINPF9520MXDK012	压紧杆提升凸轮	Presser bar lifting cam	1
3-2	JINPF5550416	O型圈P4	O-ring P4	1
5-1	JINPF9520MXDK011	膝提升左杠杆销	the left lever to enhance sales	1
5-2	JINPF9520MXDK011	抬压杠杆销	HAND LIFTER LINK ASM.	1
6	JINPF9520MXDK030	松线架	Loose wire rack	1
8-1	JINPF8420M-D30518	螺钉	Screw	1
8-2	JINPF9520MXDK027	膝控连杆	Knee link	1
8-3	JINPF9520MXDK029	膝控提升左杠杆	Raise the left knee lever control	1
8-4	JINPF5550430	螺钉3/16*32	Screw 3/16*32	1
9	JINSCJ1008	挡圈	Ring	2
9-1	JINPF9990324	抬压连杆弹簧	spring	1
9-2	JINPF9990341	抬压连杆弹簧销	PIN	1
10	JINPF5550429	后杠杆轴位螺钉	Screw	1
11-1	JINPF5550428	膝控提升右杠杆	Raise the right knee lever control	1
11-2	JINPF5550431	抬压脚顶杆	Presser Foot lift mandrel	1
12	JINPF55504102	调压锁紧螺钉	Pressure regulating thumb screw	1
13	JINPF55504102	调压锁紧螺母	Lock nut	1
14	JINPF555043	压紧杆弹簧导柱	Presser bar guide	1
15	JINPF555044	压紧杆弹簧-3	Presser spring	1
16	JINPF8520429	压紧杆	Presser bar	1
17	JINPF9520MXDK049	压紧杆导架	Presser bar lifting bracket	1
19-1	JINPF555047	螺钉11/64*40 L=11.5	Screw 11/64*40 L=11.5	1
20	JINPF5550410	压紧杆轴套	Presser bar bushing	1
21	JINPF5550412	螺钉9/64-40 L=10.5	Screw 9/64-40 L=10.5	1
22	JINPF852043507	压脚组件-3	Presser foot complete	1
23	JINPF9520MXDK030	松线钢绳	Loose wire rope	1
24	JINPF5550725	螺钉 11/64-40 L=7	SCREW 11/64-40 L=7	1
24-1	JINPF5550637	螺钉 11/64-40 L=8.5	SCREW 11/64-40 L=8.5	1
25	JINPF90000438	松线钢绳架板	Loose wire rope supporting board	1
25-1	JINPF90000432	软管支承板	WIRE HOLDER BRACKET (UPPER)	1
26	JINPF90000436	松线钢绳座	Loose wire rope Block	1
27	JINPF68425E28	螺钉 9/64-40 L=7	SCREW 9/64-40 L=7	2
28	JINPF90000438	松线固定板	Loose wire fixed plate	1
29	JINPF5550725	螺钉 11/64-40 L=7	SCREW 11/64-40 L=7	1
30	JINPF90000442	松线座	Song Line Block	1
31	JINPF9000044001	螺母	Nut	2
32	JINPF90000443	松线复位弹簧	Loose wire return spring	1
33	JINPF5550432	压杆油封	PRESSER BAR OIL SEAL	1

5. 送料装置 / FEED MECHANISM

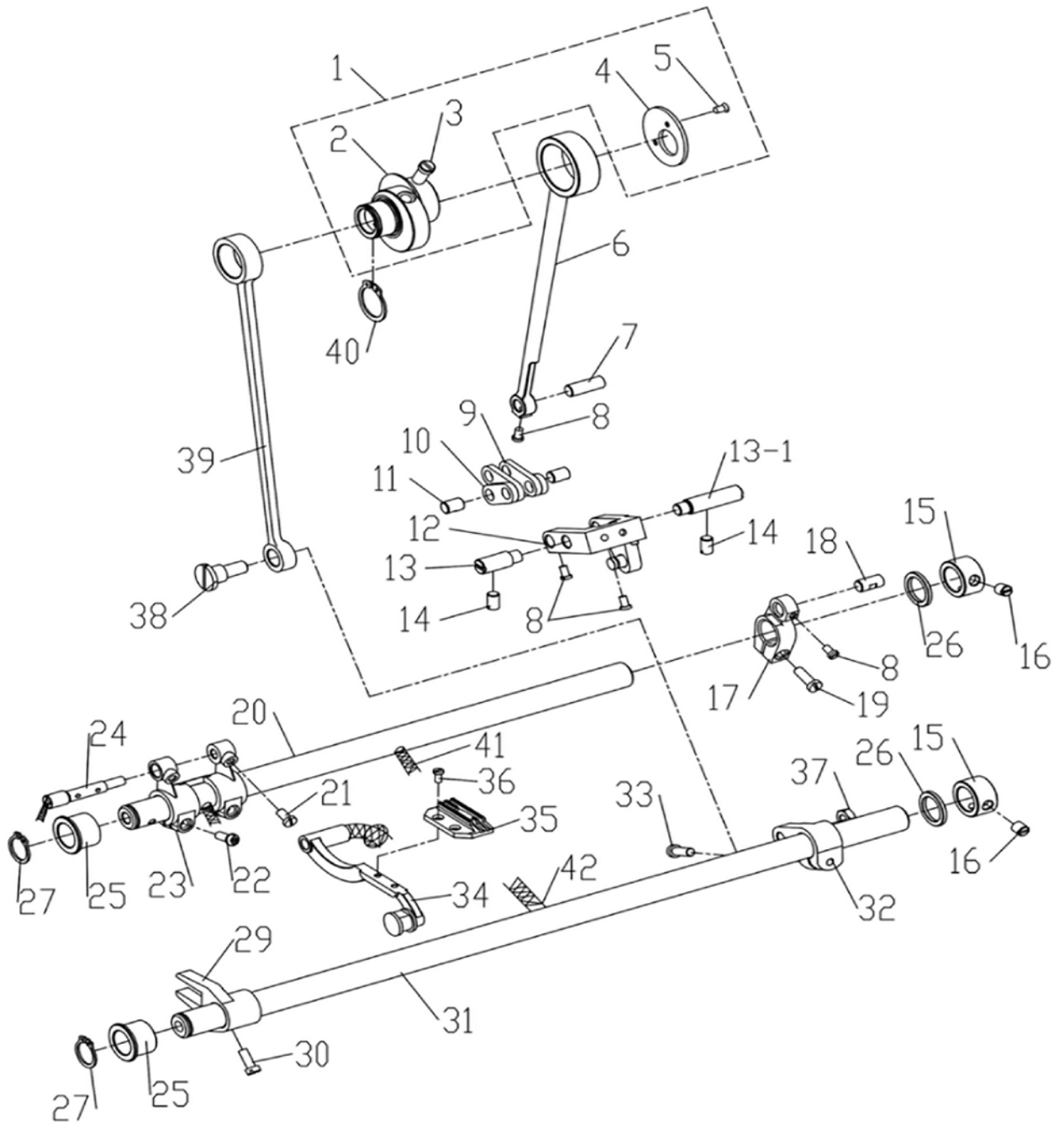

序号 Ref.No	件号 Part No	名称	Description	数量 QTY
1	JINPF98000602	电脑车偏心轮组件	FEED DRIVE ECCENTRIC CAM SAM	1
2	JINPF555062	送料偏心轮	FEED DRIVE ECCENTRIC CAM	1
3	JINPF555063	送料偏心轮螺钉	SCREW 1/4-40 L=11	2
4	JINPF555064	送料偏心轮盖板	THRUST COLLAR	1
5	JINPF555065	偏心轮盖板螺钉	SCREW 9/64-40 L=5	2
6	JINPF555066	送料连杆	ROCKER SHAFT CONNECTING ROD	1
7	JINPF555067	送料连杆销	WALKING FOOT PIN	1
8	JINPF555068	连接销螺钉	SCREW 9/64-40 L=6	4
9	JINPF555069	送料长摆动板	LONG WALKING FOOT LINK	2
10	JINPF5550610	送料短摆动板	SHORT WALKING FOOT LINK	2
11	JINPF5550611	长摆动板连接销	WALKING FOOT PIN	2
12	JINPF888056D613	送料摆动板座部件	WALKING FOOT ADJUST LINK	1
13	JINPF5550614	送料摆动板座右销	ADJUSTING LINK FULCRUM SHAFT	1
13-1	JINPF555061601	送料摆动板座右销(Φ10)	ADJUSTING LINK FULCRUM SHAFT	1
14	JINPF6150326	左右销螺钉	SCREW 15/64-28 L=7	2
15	JINPF5550653	抬牙送布紧圈	RETAINING RING	2
16	JINPF6150304	送布轴紧固螺钉	SCREW	4
17	JINPF5550618	送料曲柄	FEED ROCKER SHAFT CRANK ASM.	1
18	JINPFQ576	送料曲柄销	WALKING FOOD PIN	1
19	JINPF5550621	送料曲柄螺钉	SCREW 9/64-28 L=14	1
20	JINPF90000620	送布轴	FEED ROCKER SHAFT	1
21	JINPF90000621	牙架曲柄轴螺钉	SCREW	2
22	JINPF5550633	牙架曲柄固定螺钉	SCREW	2
23	JINPF90000623	牙架曲柄	FEED CRACKET	1
24	JINPF90000624	牙架销	FEED BAR SHAFT	1
25	JINPF90000625	送料轴前轴套	FEED ROCKER SHAFT BUSHING	2
26	JINPF6150529	抬牙送布轴轴套垫圈	WASHER	2
27	JINSCJ1036	抬牙送布轴轴用挡圈	RETAINING RING	2
29	JINPF90000629	抬牙叉型曲柄	DRIVING SHAFT CRANK ASM.	1
30	JINPF6150607	抬牙叉型曲柄螺钉	SCREW 11/64-40 L=10.5	1
31	JINPF90000631	抬牙轴	FEED DRIVING SHAFT	1
32	JINPF90000632	抬牙后曲柄	REAR CRACK ASM.	1
33	JINPF5550648	抬牙后曲柄螺钉	SCREW 3/16-28 L=12	1
34	JINPF90000634	牙架组件	FEED ROCKER BASE ASM.	1
35	JINPF852053301	送布牙(二排)	FEED DOG	1
36	JINPF5550635	送料牙螺钉	SCREW 1/8-44 L=6	2
37	JINPF5550651	抬牙连杆轴位螺母	NUT	1
38	JINPF5550650	抬牙连杆轴位螺钉	SCREW	1
39	JINPF5550649	抬牙连杆	CONNECTING ROD	1
40	JINPF5550652	抬牙连杆轴用挡圈	SNAP RING	1
41	JINPF5550627	送料轴油线	OIL WICK	1
42	JINPF5550627	抬牙轴油线	OIL WICK	1

6. 送料、调节分组件 / FEED REGULATING COMPONENTS

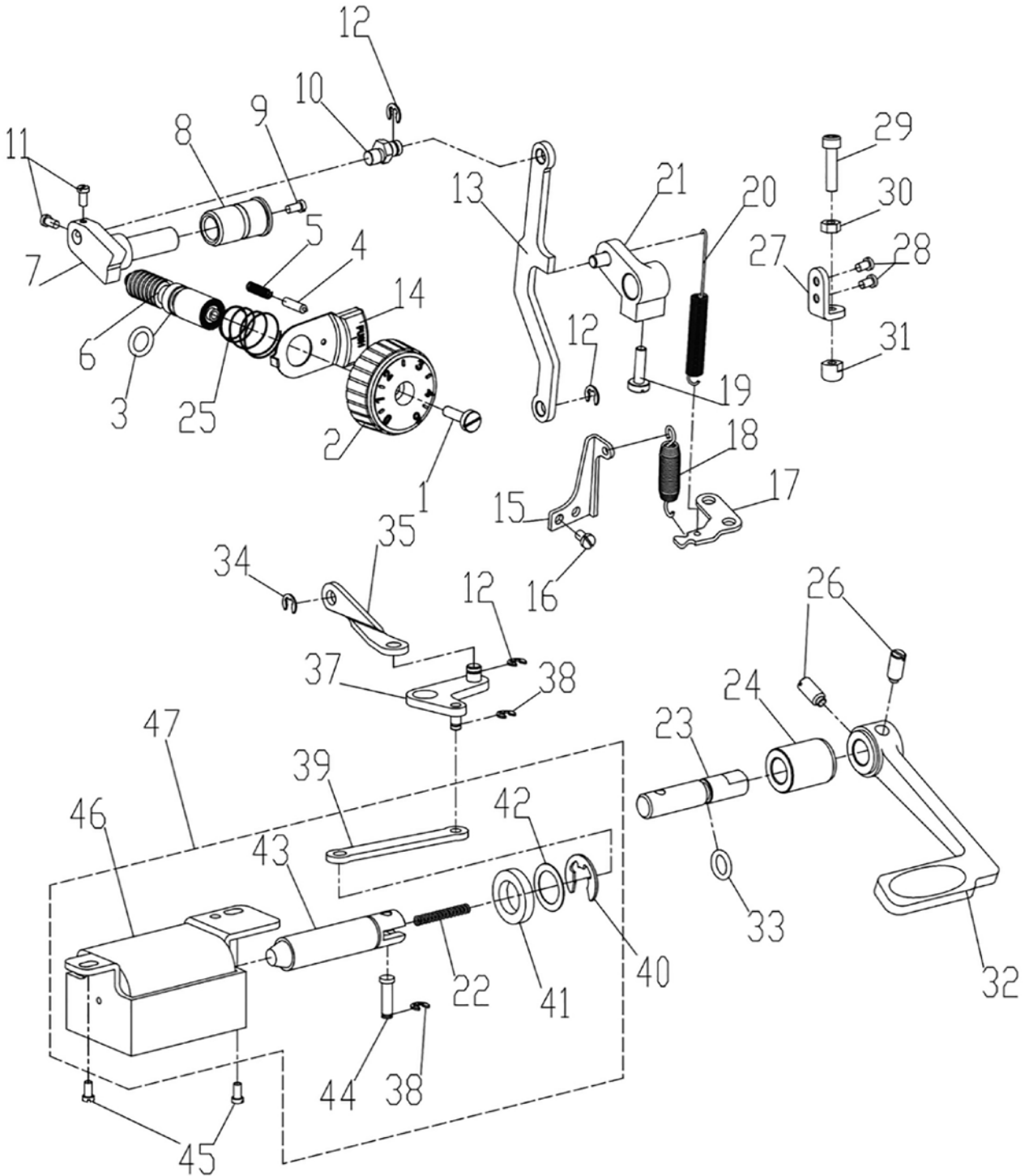

序号 Ref.No	件号 Part No	名称	Description	数量 QTY
1	JINPF555072	送料距旋钮螺钉	SCREW	1
2	JINPFQ57201	送料距旋钮	FEED DIAL	1
3	JINPF555074	送料调节螺柱O型圈	RUBBER RING	1
4	JINPF0302425	送料距锁合销	PIN	1
5	JINPF555076	送料距锁合簧	SPRING	1
6	JINPFQ576	送料调节螺柱	FEED REGULATOR SCREW	1
7	JINPF90000707	送料调节器	FEED REGULATOR	1
8	JINPF90000708	送料调节器轴套	FEED REGULATOR BUSHING	1
9	JINPF555079	送料调节器轴端螺钉	SCREW	1
10	JINPF90000710	倒送料连杆销	FEED REGULATOR PIN	1
11	JINPF68425B27	连杆销螺钉	SCREW	2
12	JINSCJ1007	倒送料连杆挡圈	SNAP RING	3
13	JINPF90000713	倒送料连杆	FEED REGULATOR CONNECTING ROD	1
14	JINPF9800070201	锁针距挡板	NEEDLE GAUGE LOCK GUIDE	1
15	JINPF5550724	摆动板座复位板	ADJUSTING LINK SPRING GUIDE	1
16	JINPF5550633	复位板螺钉	SCREW 11/64-40 L=7	2
17	JINPF98000717	拉簧固定板	FEED REVERSE HOOK	1
18	JINPF90010718	摆动板座复位簧	ADJUSTING LINK SPRING	1
19	JINPF5550721	倒送料曲柄螺钉	FEED REVERSE ARM SCREW	1
20	JINPF5550722	倒送料拉簧	FEED REVERSE SPRING	1
21	JINPF90000721	倒送料曲柄部件	FEED REVERSE ARM ASM.	1
22	JINPFS5T074609	铁芯弹簧	PLUNGER SPRING	1
23	JINPF90000723	倒送料轴	FEED REVERSE SHAFT	1
24	JINPF5550716	倒送料轴轴套	FEED LEVER METAL	1
25	JINPF0302445	送料调节旋钮弹簧	SPRING	1
26	JINPF5550330	倒送料扳手固定螺钉	SCREW	2
27	JINPF90000727	限位螺钉座	RULER RETAINING PLATE	1
28	JINPF5550633	限位螺钉座螺钉	SCREW	2
29	JINSCJ2017	扳手限位螺钉	SCREW	1
30	JINPF90000730	扳手限位螺母	NUT	1
31	JINPF90000731	限位螺钉减震垫	WASHER	1
32	JINPFQ5732	倒送料扳手	REVERSE FEED CONTROL LEVER	1
33	JINPF5550715	倒送料轴O型圈	RUBBER RING	1
34	JINSCJ1006	拉杆挡圈	SNAP RING	1
35	JINPF888056D740	自动倒送料拉杆	AUTOMATIC FEEDING ROD	1
37	JINPF888056D737	自动倒送料曲柄部件	CONNECTING ARM ASM.	1
38	JINSCJ1004	曲柄短销挡圈	SNAP RING	2
39	JINPFS5T074608	铁芯连杆	IRON CORE ROD	1
40	JINPFS5T074603	铁芯挡圈	SNAP RING	1
41	JINPFS5T074604	铁芯橡胶垫	RUBBER WASHER	1
42	JINPFS5T074605	铁芯挡圈	SNAP RING	1
43	JINPFS5T074606	铁芯	IRON CORE	1
44	JINPFS5T074607	铁芯连接销	PLUNGER ARM PIN	1
45	JINPF888056D730	安装螺钉	SCREW	2
46	JINPFS5T074601	倒送料电磁铁线圈组件	REVERSE FEED MAGNET ASM	1
47	JINPF9802646	倒送料电磁铁组件	REVERSE FEED MAGNET ASM	1

## 7. 切刀部件 / UPPER KNIFE MECHANIS

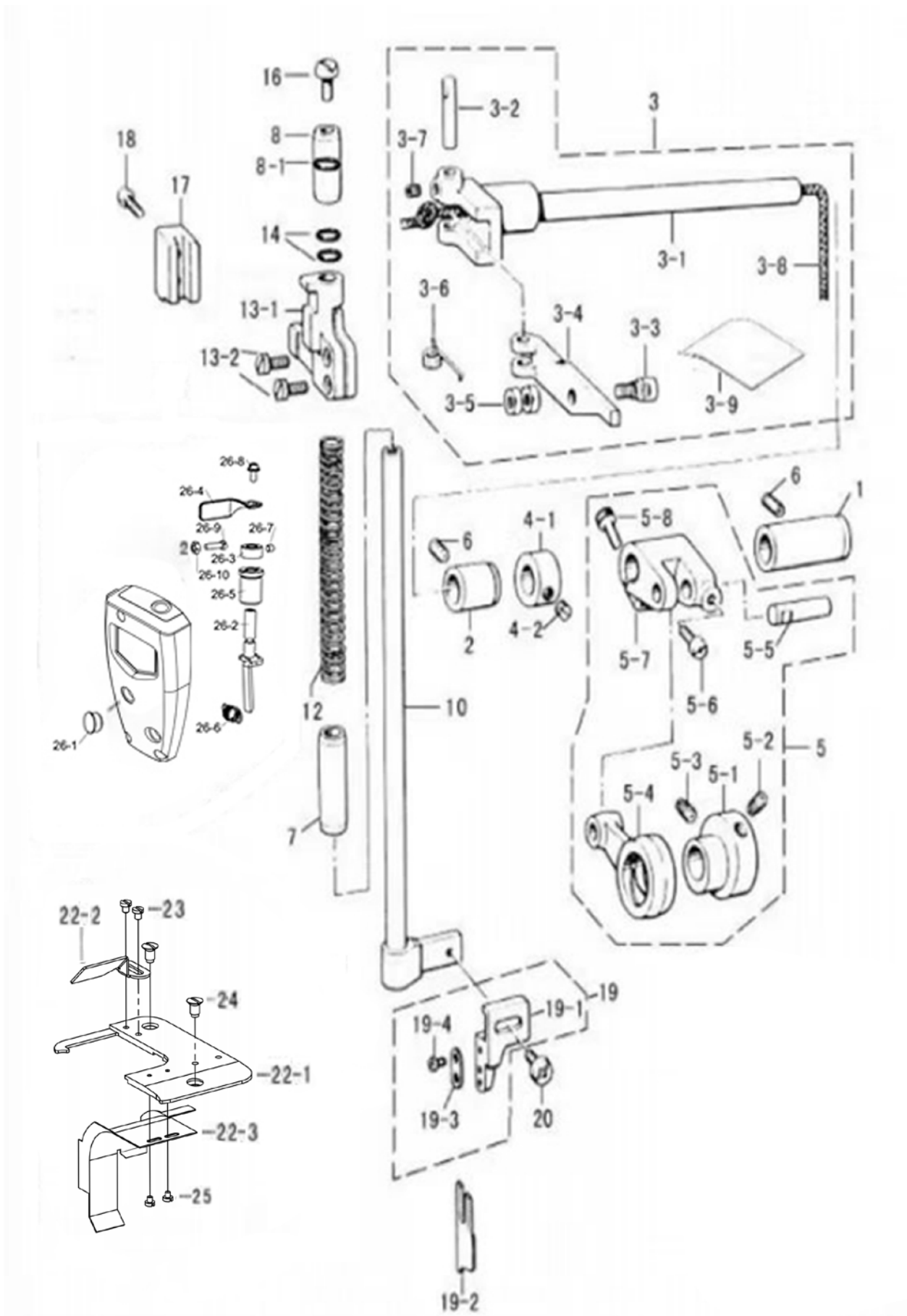



序号 Ref. No	件号 Part No	名称	Description	数量 QTY
1	JINPF9520MXDK013	切刀摆动轴套L	Rock shaft bush L	1
2	JINPF9520MXDK014	切刀摆动轴套R	Rock shaft bush R	1
3	JINPF9520MXDK046	切刀摆动轴组件	Rock shaft w/screw	1
3-1	JINPF9520MXDK046-1	切刀摆动轴	Rock shaft	1
3-2	JINPF9520MXDK046-3	驱动曲柄销	Pin	1
3-3	JINPF9520MXDK064	切刀离合销	Pin	1
3-4	JINPF9520MXDK046-2	离合柄	Clutch bracket	1
3-5	JINPF9520MXDK048	螺母	Nut	1
3-6	JINPF9520MXDK046-4	离合柄弹簧	Spring	1
3-7	JINBF700S043	紧定螺钉	Set screw	1
3-8	JINPF5550833	油线	Oil wick	1
3-9	JINPF8420M-D31112	油毡	Felt	1
4-1	JINPF9520MXDK038	驱动轴紧圈	Set screw collar	1
4-2	JINBF310164514	紧定螺钉	screw	2
5	JINPF9520MXDK047	切刀驱动凸轮组件	Knife eccentric wheel assy	1
5-1	JINPF9520MXDK04701	切刀驱动凸轮	Knife eccentric wheel	1
5-2	JINPF55506461	螺钉	Set screw	1
5-3	JINPF55506461	螺钉	Set screw	1
5-4	JINPF9520MXDK04703	摆动连杆	Rock connecting rod	1
5-5	JINPF9520MXDK018	摆动曲柄销	Pin	1
5-6	JINPF7810911	螺钉	Set screw	1
5-7	JINPF9520MXDK062	摆动曲柄	Rock arm	1
5-8	JINBF700S039	螺钉	Set screw	2
6	JINPF5550330	紧定螺钉15/64X28 L=7	Set screw 15/64X28 L=7	2
7	JINPF9520MXDK016	切刀下轴套	Knife shaft bush D	1
8	JINPF9520MXDK015	切刀上轴套	Knife shaft bush U	1
8-1	JINSCJ1017	卡簧	C-type stop ring	1
10	JINPF9520MXDK006	切刀轴	Knife shaft	1
12	JINPF9520MXDK019	切刀轴弹簧	Spring assy	1
13-1	JINPF9520MXDK005	切刀轴导向架	Knife shaft guide	1
13-2	JINBF700S039	螺钉11/64*40-9.5	screw 11/64*40-9.5	2
14	JINPF90008133	缓冲垫	O ring P9	2
16	JINPF9520MXDK042	切刀轴扳手螺钉	Screw	1
17	JINPF9520MXDK002	切刀轴导向	Knife shaft guide	1
18	JINPF5550412	螺钉9/64X40 L=10.5	Screw 9/64X40 L=10.5	2
19	JINPF9520MXDK045	切刀架组件	Knife holder	1
19-1	JINPF9520MXDK04501	切刀架	Knife holder	1
19-2	JINPF9520MXDK020	切刀	Upper knift	1
19-3	JINPF9520MXDK04502	切刀压板	Knife washer	1
19-4	JINPF9520MXDK04503	切刀压板螺钉	Scerw bind	2
20	JINPF68425K25	螺钉	Set screw	1
22-1	JINPF8520149	右推板	Needle plate	1
22-2	JINPF9520MXDK06101	下料挡板	Waste conductor	1
22-3	JINPF852014801	排屑罩	Waste funnel	1
23	JINBF8007008	螺钉	Screw	2
24	JINPF9520MXDK054	右推板螺钉	Needle plate screw	2
25	JINPF5550834	螺钉	Screw	2
26-1	JINPF8420M-D3010107	孔塞	Rubber plug	3
26-2	JINPF9520MXDK026	复位扳手轴位螺钉	Shouler screwc	1
26-3	JINPF68425D1901	扳手轴位螺钉垫圈	Shouler screwc	1
26-4	JINPF9520MXDK024	复位扳手	Clear lever	1
26-5	JINPF9520MXDK023	扳手弹簧复位套	Collar	1
26-6	JINPF9520MXDK035	复位扳手弹簧	Spring	1
26-7	JINPF68425D1902	螺钉	Screw	2
26-8	JINSCJ2038	螺钉	Screw	1
26-9	JINPF68425D22	螺钉	Screw	1
26-10	JINPF68425D23	螺母	Nut	1

## 8. 剪线分组件 / THREAD TRIMMER COMPONENTS

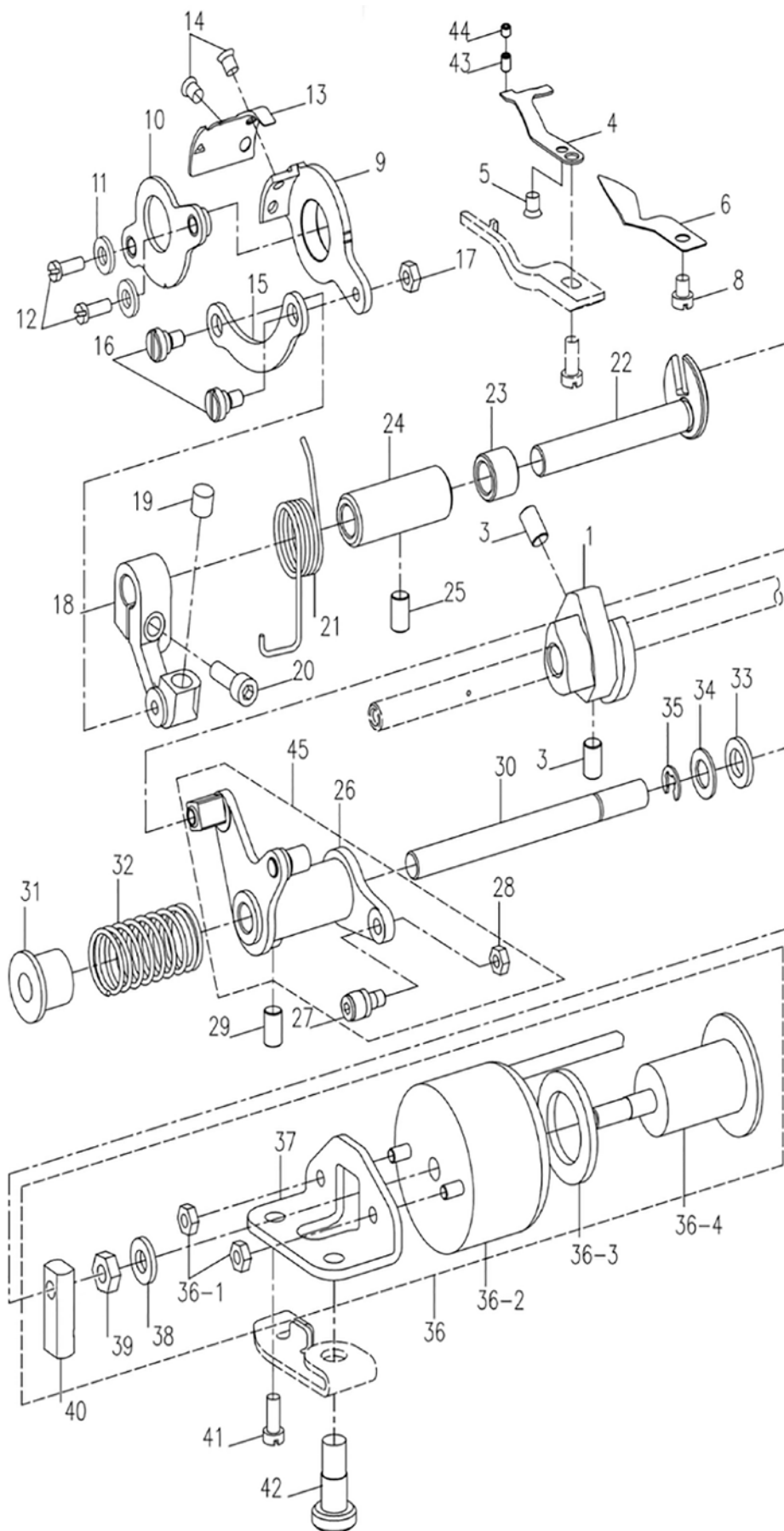

序号 Ref. No	件号 Part No	名称	Description	数量 QTY
1	JINPF90008101	剪线凸轮	THREAD TRIMMER CAM	1
3	JINPF90008103	剪线凸轮螺钉	SCREW 1/4-40 L=10	2
4	JINPF90008104	定刀	CONNTER KNIFE	1
5	JINPF68425H26	定刀固定螺钉	SCREW	1
6	JINPF90008106	分线器	DISPART THREAD SHUTTLE	1
8	JINPF6150211	分线器固定螺钉	SCREW	1
9	JINPF90008109	动刀架	ROUND KNIFE BRACKET	1
10	JINPF90008110	刀架压板组件	KNIFE HOLDER ASM	1
11	JINPF5550630	刀架压板垫圈	WASHER	2
12	JINPF90008112	刀架压板螺钉	SCREW	2
13	JINPF9000811301	动刀	ROUND KNIFE	1
	JINPF90008113	动刀(厚)	ROUND KNIFE	1
14	JINPF90008114	动刀固定螺钉	SCREW	2
15	JINPF90008115	刀轴连杆	KNIFE SHAFT CRANK ROD	1
16	JINPF90008116	刀轴连杆螺钉	SCREW	2
17	JINPF90008117	刀轴连杆螺母	NUT	1
18	JINPF90008118	切线驱动曲柄	TRIMMING CRANK	1
19	JINPF90008118SF01	切线驱动曲柄止动块	BLOCK	1
20	JINPF9000812001	切线驱动曲柄螺钉	SCREW	1
21	JINPF90008121	复位弹簧	REPLACE SPRING	1
22	JINPF90008122	切线驱动曲柄轴	TRIMMING CRANK SHAFT	1
23	JINPF90008123	驱动曲柄轴短套	SHORT BUSHING	1
24	JINPF90008124	切线轴套	BUSHING	1
25	JINPF55506461	切线轴套紧定螺钉	SCREW	1
26	JINPF9000812603	切线凸轮曲柄	TRIMMING CAM CRANK	1
27	JINPF9000812602	滚柱轴分组件	ROLLER BEARING SHAFT ASM.	1
28	JINPFQ5F070309	螺母	NUT 11/64-40	1
29	JINPF90008129	切线凸轮曲柄紧定螺钉	SCREW 1/4-40 L=6	1
30	JINPF90008130B	切刀驱动轴	TRIMMING SHAFT	1
31	JINPF90008131	扭簧端盖	SPRING COVER	1
32	JINPF90008132	剪线电磁铁复位弹簧	SPRING	1
33	JINPF90008133	切线磁铁垫圈	WASHER	1
34	JINPF90008134	切线驱动轴垫圈	CLIP	1
35	JINSCJ1009	切线驱动轴卡圈	WASHER	1
36	JINPF9802804	剪线电磁铁组件	THREAD TRIMMER SOLENOID ASM.	1
36-1	JINPF980280401	螺母(M4)	NUT(M4)	2
36-2	JINPF980280406	电磁铁线圈组件	ELECTROMAGNET COIL ASSEMBLY	1
36-3	JINPF9802804SF01	垫圈	WASHER	1
36-4	JINPF980280408	铁芯	IRON CORE	1
37	JINPF980280402	剪线电磁铁安装座	SOLENOID BASE	1
38	JINPF980280403	电磁铁缓冲垫	SOLENOID CONNECTING SHAFT	1
39	JINPF980280404	垫圈	WASHER	1
40	JINPF980280405	切线电磁铁连接体	SOLENOID CONNECTING SHAFT	1
41	JINPF90008141	剪线电磁铁架固定螺钉	SCREW 1/4-28	1
42	JINPF90008142	松线座螺钉	SCREW 1/4-28	1
43	JINPF900081412	定刀顶紧螺钉	SCREW 1/8-44X6	1
44	JINBF7005292	定刀顶紧螺钉	SCREW 1/8-44X3	1
45	JINPF90008126	切线凸轮曲柄组件	TRIMMING CAM CRANK ASM.	1

9. 电子夹线组件 / ELECTRIC CLAMP COMPONENTS

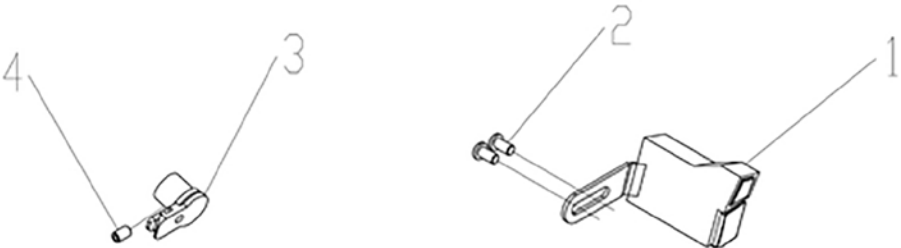

序号 Ref. No	件号 Part No	名称	Description	数量 QTY
1	JINPFC1A0801	照明灯	REVEVSE SEWING SWITCH	1
2	JINPF555016	照明灯固定螺钉	SCREW	2
3	JINPFQ595	电子夹线器	ELECTRIC CLAMP	1
4	JINPF5550330	电子夹线器固定螺钉	SCREW	1

# 10. 润滑装置 / OIL LUBRICATION MECHANISM

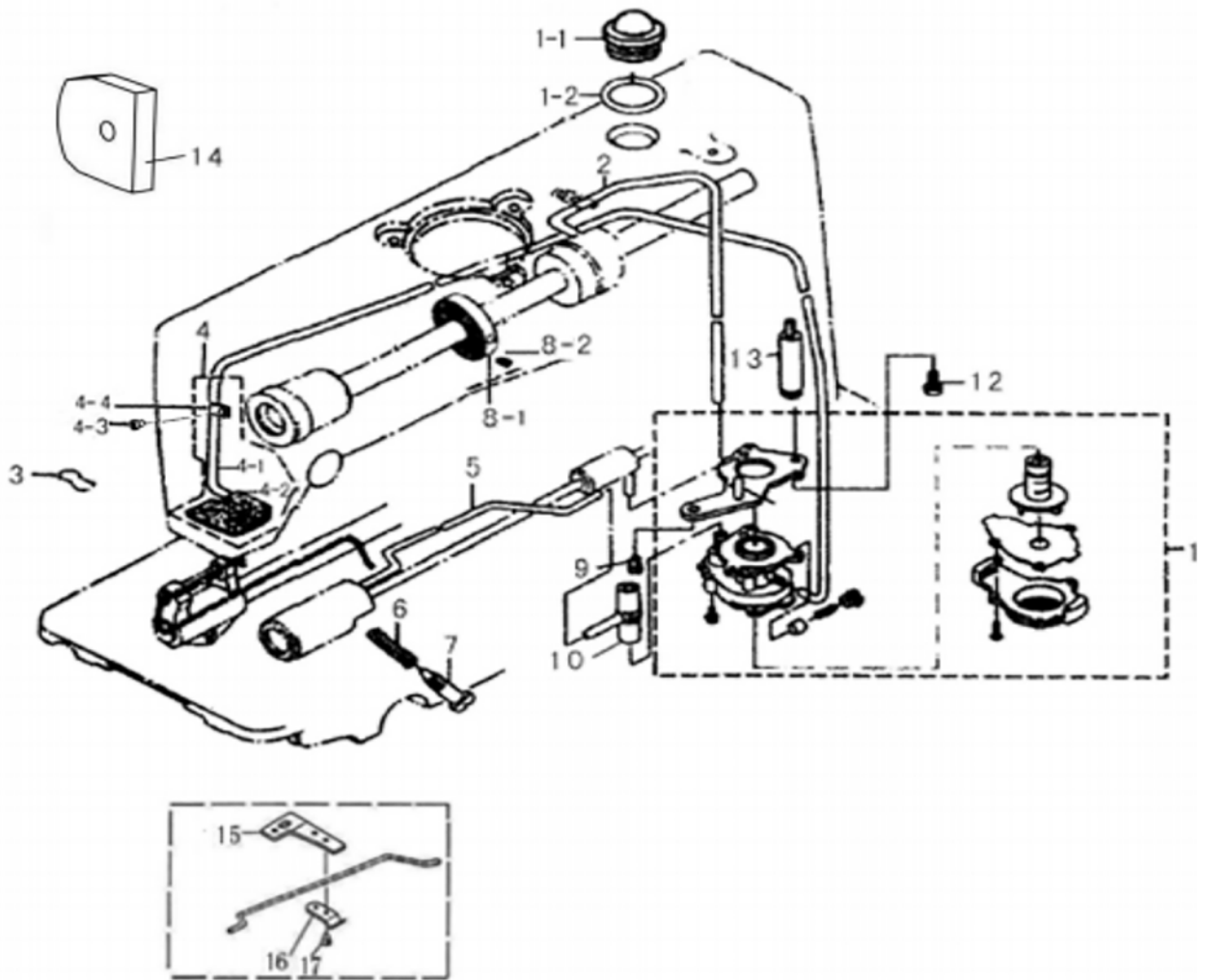

序号 Ref. No	件号 Part No	名称	Description	数量 QTY
1-1	JINPF5550824	油窗	Oil cap	1
1-2	JINPF5550825	O型圈	Oing, PW14	1
2	JINPFC1A1002	四自动油管(内置)	On the shaft for the pipeline	1
3	JINPF5550831	滤油毡压簧	Filter felt compression spring	1
4	JINPF9520YGZJ	回油管组件	Oil return pipe assy	1
4-1	JINSCJ5030	回油管	Oil return pipe	1
4-2	JINPF555083001	机头回油滤油毡	Felt pouch	1
4-3	JINPF5550230	螺钉	Screw	1
4-4	JINPF5550827	回油管夹	Oil return tube holder	1
5	JINPF90001022	旋梭供油管	Hook for tubing	1
6	JINPF90001024	调节弹簧	Adjusting spring	1
7	JINPF90001023	调节螺钉	Screw	1
8-1	JINPF90000237	绕线驱动轮	Winder wheel	1
8-2	JINPF68425H33	螺钉11/64X40 L=6	Screw 11/64X40 L=6	2
9	JINPF2284014802	油泵螺钉	Screw	1
10	JINPF5550817	供油管接头	For pipe joints	1
11	JINPF555081	油泵组件	Pump components	1
12	JINPF555056	油泵连接螺柱螺钉	Stud screw pump connection	1
13	JINPF888056D1017	油泵连接螺柱	Pump connection stud	1
14	JINPF90011038	海绵	Sponge	1
15	JINPF888056D442	软管下支撑板	Wire holder barcket(lower)	1
16	JINPF888056D437	软管下支撑板压板	Wire holder	1
17	JINPF5550725	螺钉 11/64-40 L=7	SCREW 11/64-40 L=7	1

11. 油盘装置 / OIL RESERVOIR MECHANISM

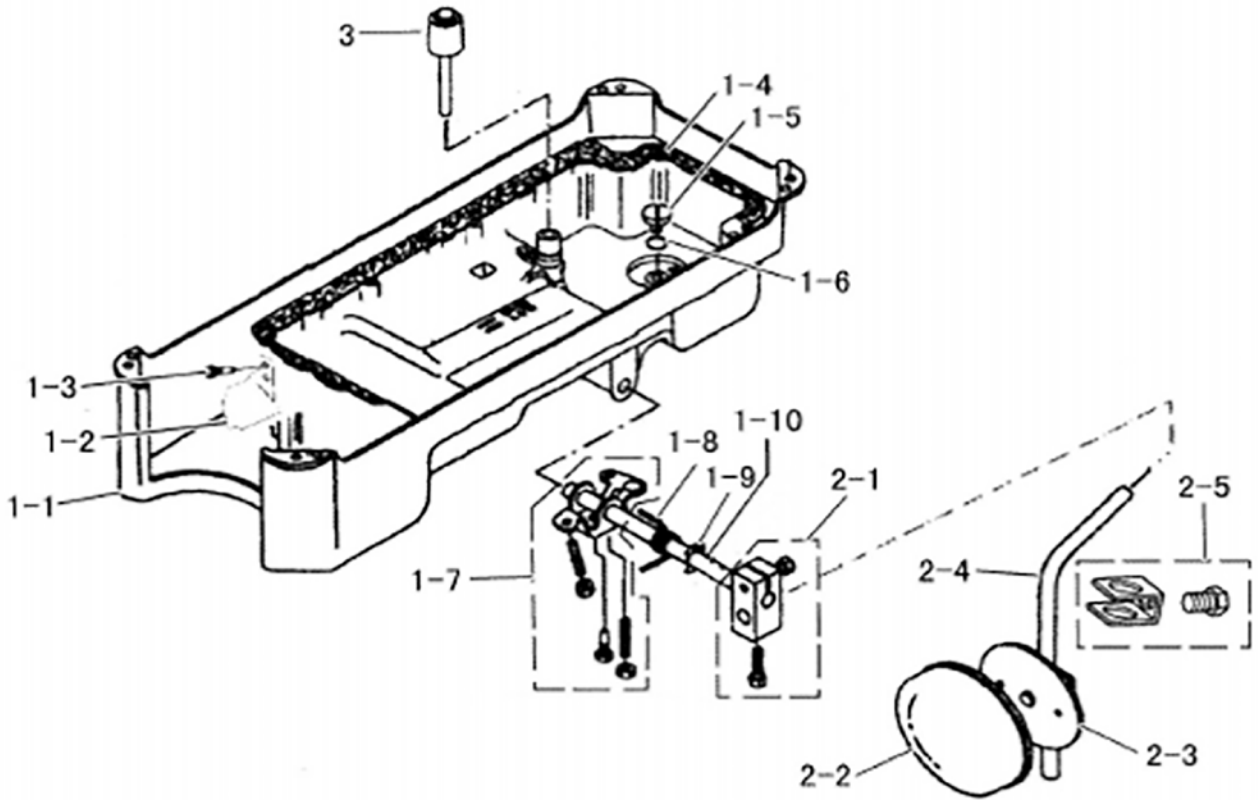



序号 Ref.No	件号 Part No	名称	Description	数量 QTY
1—1	JINPF8520802	油盘	Oil reservoir	1
1—2	JINPF8520824	油盘导油板	Oil reservoir stopper plate	1
1—3	JINPF5550317	螺钉	Screw	2
1—4	JINPF555093	油盘垫	Gasket for oil reservoir	1
1—5	JINPF555095	排油孔螺钉	Screw	1
1—6	JINPF555096	排油螺钉O形圈	O rin	1
1—7	JINPF5550912	膝控限位架组件	Knee lifter stop bracket assy	1
1—8	JINPF5550916	膝控复位簧	Twist spring	1
1—9	JINSCJ1014	膝控复铰链轴挡圈	Retaining ring e10	1
1—10	JINPF5550917	膝控铰链轴	Knee lifter shaft	1
2—1	JINPF5550919	碰块弯杆接头组件	Joint for knee lifter bell crank	1
2—2	JINPF5550924	碰块垫	Knee lifter plate	1
2—3	JINPF5550925	膝控碰块	Knee lifter plate assy	1
2—4	JINPF5550922	膝控弯杆	Knee lifter bar	1
2—5	JINPF5550926	碰块架组件	Bracket far knss lifter plate	1
3	JINPF5550911	顶杆	Mandrel	1

12. 附件 / ACCESSORIES

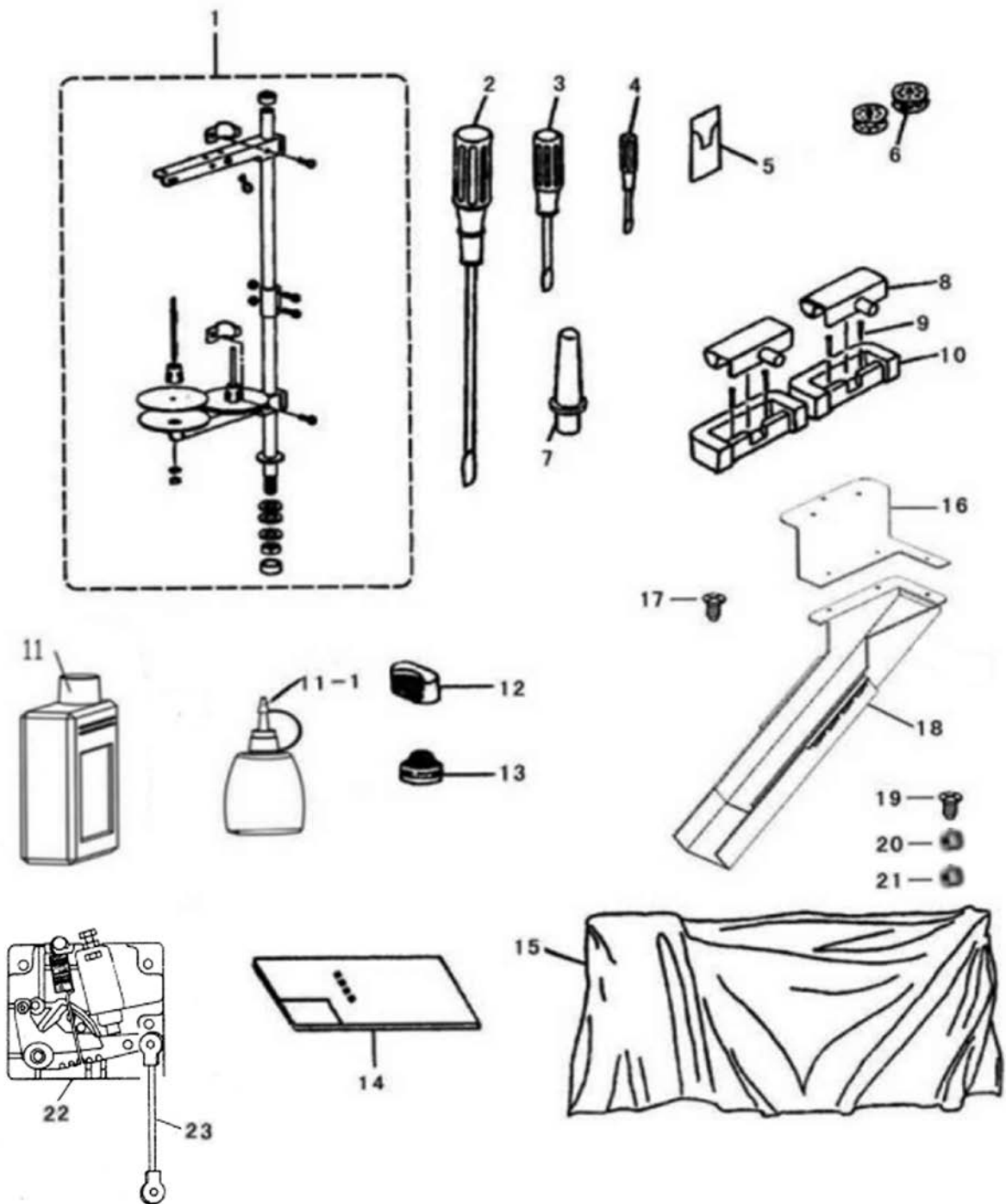



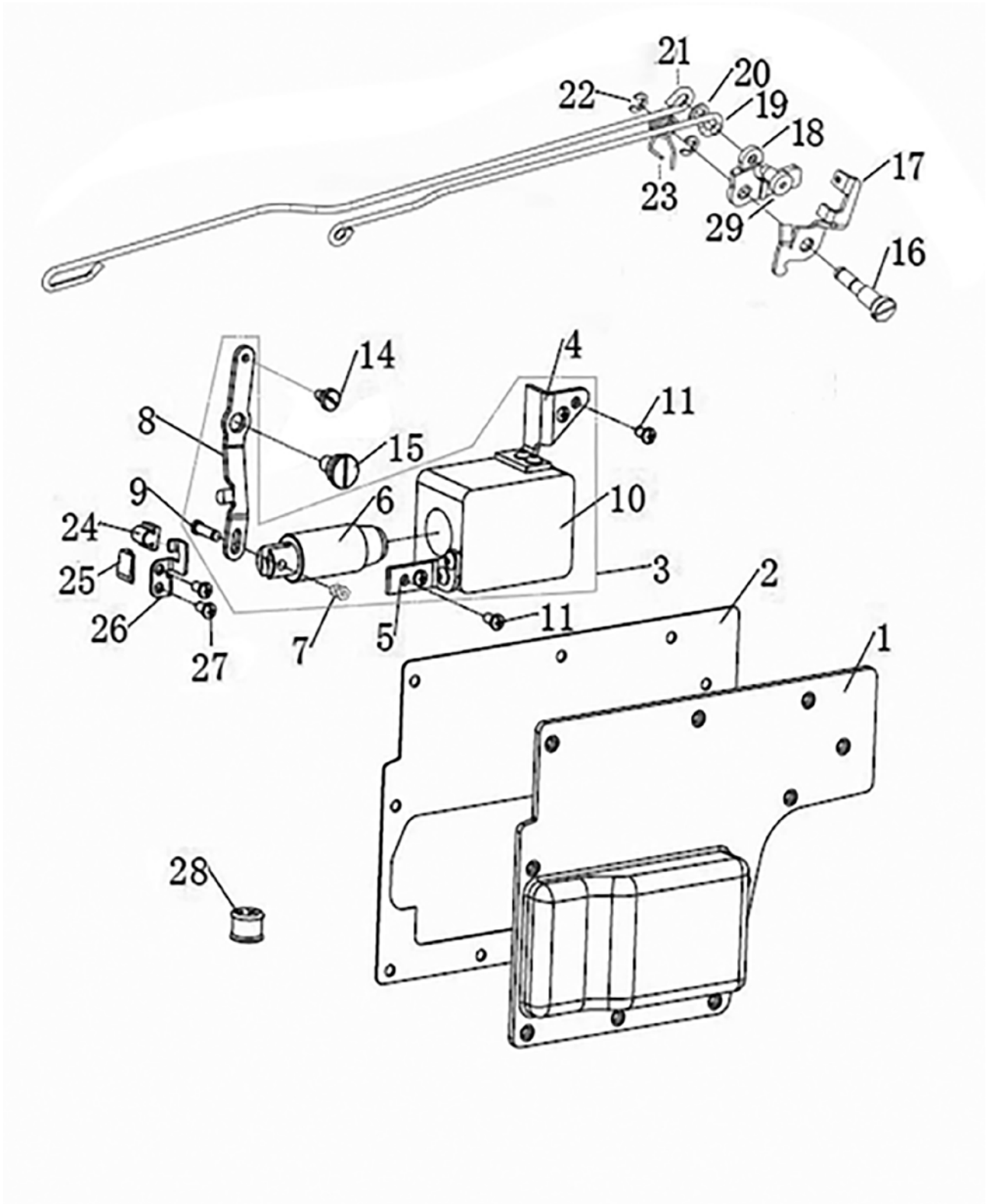

序号 Ref. No	件号 Part No	名称	Description	数量 QTY
1	JINPF5550112701	线架组件	THREAD STAND AMS	1
2	JINPF55501016	螺丝刀 (大)	SCREW DRIVER (LARGE)	1
3	JINPF55501017	螺丝刀 (中)	SCREW DRIVER (MIDDLE)	1
4	JINPF55501018	螺丝刀 (小)	SCREW DRIVER (SMALL)	1
5	JINPFDTDB114	机针	NEEDLE	4
6	JINPF555053	梭心	BOBBIN	2
7	JINPF55501021	机头支柱	FRAME SUPPORT BAR	1
8	JINPF5550101	机头连接钩	HINGE COMPL	2
9	JINSCJ6018	机头连接钩钉	RUBBER CUSHION NAIL	4
10	JINPF5550102	机头连接钩座	RUBBER CUSHION	2
11	JINPF55501022	油壶	OILER ASM.	1
11—1	JINPF61501105	小油壶	SMALL OILER ASM.	1
12	JINPF555099	机头大防震块	NOSE SUPPORT	2
13	JINPF555098	机头小防震块	DIE CUSHION	2
14	JINPF5550102301	附件拉链袋	Accessory zipper bag	1
15	JINPF0303104004	机头罩	FRAMEVINYL COVER	1
16	JINPF8520831	小漏斗	Little funnel	1
17	JINSCJ2073	木螺钉	Self tapping screw	4
18	JINBF31016059050	漏斗	Funnel	1
19	JINPF5550412	螺钉	SCREW	4
20	JINSCJ5093	垫片	SHIM	4
21	JINPF68425D23	螺母	NUT	4
22	JINPFQ5TE2014411	脚踏开关	FOOT SWITCH	1
23	JINPF90001318	脚踏连杆	FOOT LINKAGE	1

13. 自动抬压脚组件 / AUTOMATIC PRESSER FOOT LIFTER COMPONENTS

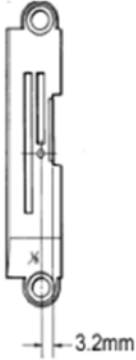
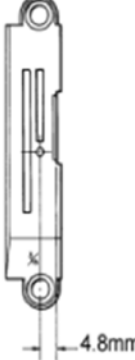
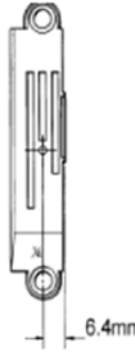

序号 Ref. No	件号 Part. No	名称	Description	数量 QTY
1	JINPFC1A0115	后窗板	FACE PLATE	1
2	JINPFC1A0114	后窗板垫	FACE PLATE GASKET	1
3	JINPFS5T1403	抬压脚电磁铁组件	PRESSER FOOT SOLENOID ASM.	1
4	JINPFQ514301	右支架	RIGHT STAND	1
5	JINPFQ514302	左支架	LEFT STAND	1
6	JINPFQ514303	抬压脚电磁体铁芯	SOLENOID CORE	1
7	JINPFQ514304	螺母	NUT	2
8	JINPFQ514305	摆动杆	CRANK ROD	1
9	JINPFQ514306	铁芯连接销	IRON-CORE CONNECTING PIN	1
10	JINPFQ514307	电磁铁线圈基体	PRESSER FOOT SOLENOID	1
11	JINPF5550161	支架固定螺钉	SCREW 3/16-28 L=12	4
14	JINPF7810616	长拉杆连接螺钉	SCREW	1
15	JINPFQ51415	摆动杆轴位螺钉	SCREW	1
16	JINPF9520MXDK011	抬压杠杆销	HAND LIFTER LINK ASM.	1
17	JINPF9520MXDK030	松线板组件		1
18	JINPF9520MXDK029	抬压杠杆	Raise the left knee lever control	1
19	JINPF9520MXDK027	抬压脚拉杆	LIFTING LEVER CONNECTING ROD	1
20	JINPF1310D245	垫片	Gasket	1
21	JINPFQ5141601	自动抬压脚拉杆(长)	CONNECTING ROD(LONG)	1
22	JINSCJ1008	连接卡簧	SNAP RING	2
23	JINPF9990324	抬压连杆弹簧	spring	1
24	JINPFQ51422	缓冲垫	RUBBER PLUG	1
25	JINPFS5T1423	防护垫	PROTECTIVE PAD	1
26	JINPFS5T1424	防撞板(带压板)	BUMPER PLATE	1
27	JINPF5550230	螺钉	SCREW	2
28	JINPF9800TD406	电线过线套(三孔)	WIRE CROSSING SLEEVE (THREE HOLES)	1
29	JINPF9520MXDK068	轴位螺钉	SCREW	1

14. 针位零件一览表 / NEEDLE POSITION PARTS LIST

标准 GUAGE	D	F	H
针板 NEEDLE PLATE	 <p>3.2mm</p> <p>1/8 JINPF852013502</p>	 <p>4.8mm</p> <p>3/16 JINPF852013501</p>	 <p>6.4mm</p> <p>1/4 JINPF852013503</p>
送布牙 FEED DOG	 <p>JINPF852053301</p>		 <p>JINPF030231</p>
压脚组件 PRESSER FOOT ASM.	 <p>JINPF8520435</p>		 <p>JINPF852043501</p>

JUKI CORPORATION  
2-11-1, TSURUMAKI, TAMA-SHI, TOKYO 206-8551, JAPAN  
PHONE: (81) 42-357-2211