





## AP-876 用バーコード読み取り装置 (オプション) Bar code reader for AP-876 (optional) AP-876 用条码阅读器 (选购项目)

# 取扱説明書 INSTRUCTION MANUAL 使用说明书



安全に使用していただくために使用前に、必ずこの取扱説明書をお読みください。  
また、いつでもすぐに読めるように、この取扱説明書を保管してください。

 <b>警告</b>	<ul style="list-style-type: none"> <li>・バーコード読み取り装置のレーザー光を直接覗かないでください。目に障害を及ぼす場合があります。</li> <li>・人の目に向けてレーザー光を射出させないでください。目に障害を及ぼす場合があります。</li> <li>・光学機器で直接レーザー光を覗き込まないでください。目に障害を及ぼす場合があります。</li> </ul>
 <b>注意</b>	<p>当製品を装着する際は、必ずミシンの電源スイッチを切ってください。 また、ミシンの取扱説明書をあわせてお読みください。</p>

Be sure to read this instruction manual before using the product for safe use of the product.  
Furthermore, keep this instruction manual close by so that it is available whenever needed.

 <b>WARNING :</b>	<ul style="list-style-type: none"> <li>・ Do not look directly into the laser beam of the bar code reader. The laser beam can damage eyes.</li> <li>・ Do not emit laser beam toward human eyes. The laser beam can damage eyes.</li> <li>・ Do not look into the laser beam directly using an optical device. The laser beam can damage eyes.</li> </ul>
 <b>CAUTION :</b>	<p>When installing this product, be sure to turn OFF the power of the sewing machine. Furthermore, read the instruction manual of the sewing machine as well.</p>

为了安全地使用，请您在使用之前一定阅读本使用说明书。  
另外，请您注意保管本使用说明书，以便随时查阅。

 <b>警告</b>	<ul style="list-style-type: none"> <li>・ 请不要直接用眼睛去看条码阅读器的激光光线。有可能伤害眼睛。</li> <li>・ 请不要对着人的眼睛放射激光。有可能伤害眼睛。</li> <li>・ 请不要用光学仪器直接窥看激光光线。有可能伤害眼睛。</li> </ul>
 <b>注意</b>	<p>安装本产品时，请一定关掉缝纫机的电源开关。 另外，请同时参阅缝纫机的使用说明书。</p>



日本語

# 目次

1. 取り付け手順.....	1
2. バーコードの貼付け .....	2
3. バーコード機能について.....	2
4. バーコード機能の設定 .....	3
5. 使用方法.....	4
6. バーコード構成.....	5
7. バーコードリーダーの動作不良について.....	6



# 注意

不意の起動による事故を防ぐため、必ず電源を切ってから行ってください。

## 1. 取り付け手順

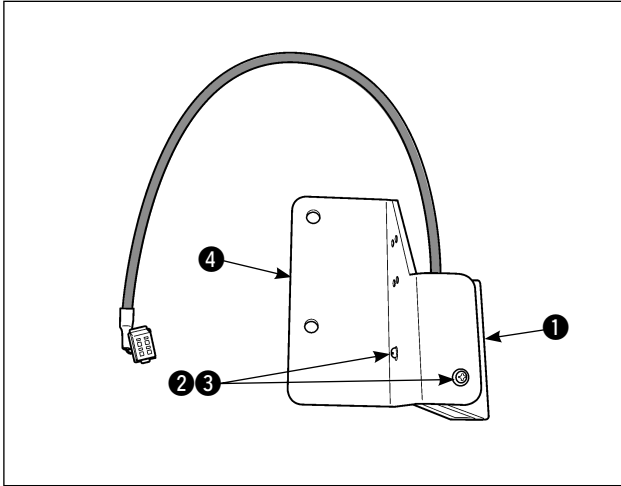

- 1) バーコードリーダー ① を付属のねじ ②、座金 ③ で取付板 ④ に取り付けます。  
(2箇所)

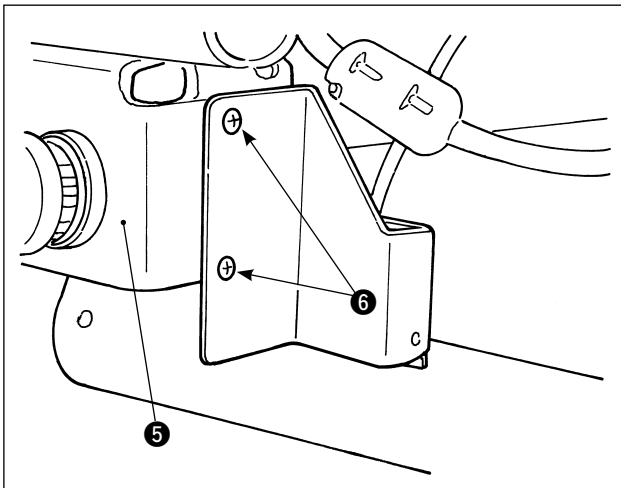

- 2) 一時停止スイッチ ⑤ に付属の取付板止めねじ ⑥ で固定します。

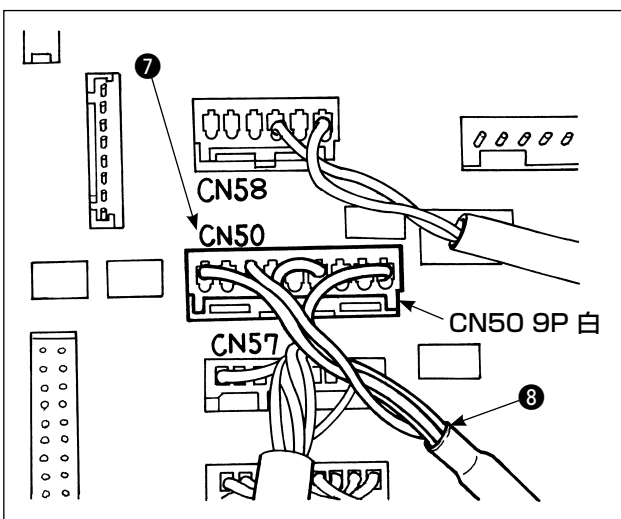

- 3) 電装ボックスを開けて、MAIN基板のCN50 ⑦ に中継ケーブル ⑧ を接続します。



## 警告

- ・バーコード読み取り装置のレーザー光を直接覗かないでください。目に障害を及ぼす場合があります。
- ・人の目に向けてレーザー光を射出させないでください。目に障害を及ぼす場合があります。
- ・光学機器で直接レーザー光を覗き込まないでください。目に障害を及ぼす場合があります。



## 注意

- ・ミシンの使用温度範囲内および使用湿度内で使用してください。
- ・電源を供給した状態でコネクタの抜き差しをしないでください。

## 2. バーコードの貼付け

バーコードは取扱説明書の巻末に添付されたものをコピーして使用してください。

## 3. バーコード機能について

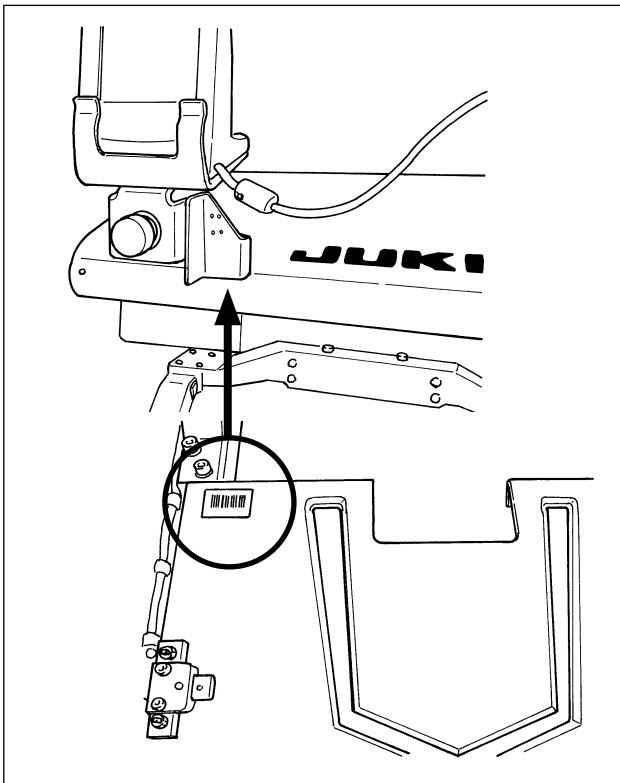

バーコード機能とは、カセット識別等の用途で、バーコードを読み取り、対応した縫製パターンに切り替えて縫製できる機能です。

バーコードの読み取りにより、ミシンメモリ内に保存されたユーザパターン 999 個、パターンボタンに登録されている縫製データ 50 個に切り替えることが可能です。

使用するためには、AP-876 バーコードオプションが必要になります。

### バーコードリーダー仕様

クラス 2 レーザー製品

最大出力：1.0mW

波長：650nm

### 安全規格

JIS C 6802:2005



IEC60825-1+A2:2007

## 4. バーコード機能の設定

### 4-1. バーコード機能の設定

メモリスイッチ K130 では、バーコードモードを選択します。メモリスイッチ K130(レベル 2) の選択方法は、サービスマニュアルを参照ください。



設定	内容	説明
	標準モード	バーコードを使用しません。
	バーコードモード	バーコードを使用します。

### 4-2. バーコード種別の選択

メモリスイッチ K142 では、バーコード種別を選択します。初期状態では Code39 のみ読み取ります。付録のバーコードを印刷して使用する場合、K142 の変更は不要です。



設定	内容	説明
	Code39	Code39 のみ読み取ります。
	全規格	バーコードリーダーの対応する全規格を読み取ります。 JAN、EAN、UPC-A/E、EAN-8/13 Add-on、UPC-A/E Add-on、Industrial2of5、IATA、Interleaved2of5、NW-7(Codabar)、Code39、Code93、Code128、EAN-128、S-Code、MSI/Plessey、RSS、Tri-Optic、CODE11、UK/Plessey、Matrix 2of5、Chinese Post Matrix 2of5、TELEPEN

## 5. 使用方法

バーコードによる縫製パターン No 読み込み動作は「型交換モード時のみ有効です。」

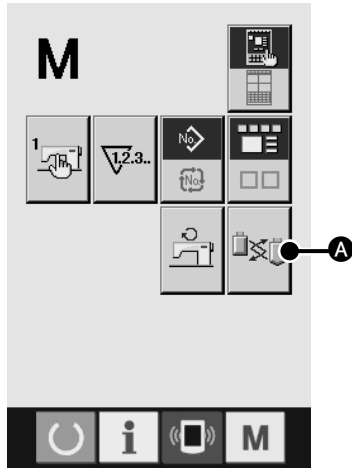

### 1) 型交換モードの起動

モードキー **M** を押すと、画面上に型交換モードボタン

 **A** が表示されます。このボタンを押すと、型交換モード画面が表示されます。

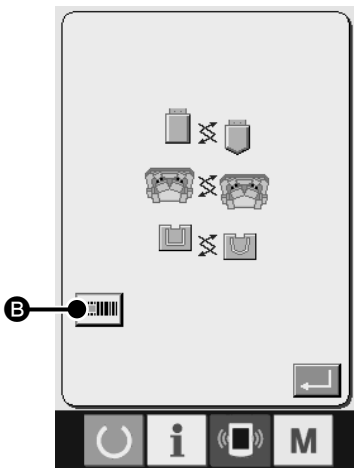

型交換モード画面



### 2) バーコードモードの時は、バーコードモード表示

**B** が画面に表示されます。

型交換モード画面を表示しているときのみ、バーコードリーダから読み取りレーザが発光され、バーコードを読むことができます。

バーコードを正常に読み取るとバーコードリーダから読み取りレーザが消えます。

## エラーコード一覧

エラーコード	ピクト	エラー内容	表示メッセージ	復帰方法	復帰場所
E010		バーコードで指定されたパターンが登録されていない。	指定されたパターンはありません。	リセット 後再復帰 可能	前画面
E058		読み取り位置にバーコードがない。 バーコードのデコードに失敗した。 通信タイムアウト	バーコード読 取りエラー	リセット 後再復帰 可能	前画面
E921		バーコードリーダがミシンに接続 されていない。 バーコードのフォーマット異常	バーコード リーダ通信 エラー	電源 OFF	



## 6. バーコード構成

巻末の付録にあるバーコードシートを読み取ることで、対応する縫製パターンに切り替えることができます。切り離してお使いください。バーコードシートは Code39 の規格に対応しています。

Code39 以外の規格でバーコードを作成する場合、下記フォーマットに従って作成してください。

- ・ 4 バイト ASCII コード
- ・ "パターン種別"、"百の位"、"十の位"、"一の位"

ex.

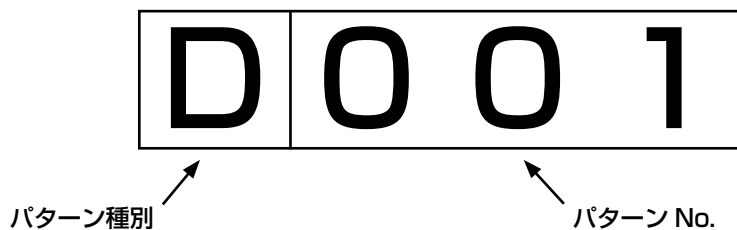

### パターン種別

U または 0 : ユーザパターンに対応します。

D または 1 : パターンボタンに登録されている縫製データに対応します。

### パターン No.

ユーザパターン : No.001 ~ No.999

パターンボタンに登録されている縫製データ : No.001 ~ No.050

種別、No それぞれ、ASCII コードで記述してください。

上記 D001 の場合、0x44 0x30 0x30 0x31 となります。

スタート/ストップキャラクタ等、使用するバーコード規格に従って作成してください。

バーコードは両側の余白が小さいと、読み取りエラーになる場合があります。そのため、両側の余白はできる限り大きくしてください。巻末の付録にあるバーコードを使う場合には、コピーしてから切り取り線で切り分けてください。

## 7. バーコードリーダーの動作不良について

バーコードリーダーが読み取りを行わない場合、バーコードリーダー側面にある SCAN ボタンを押して、レーザーが発光することを確認してください。

SCAN ボタンを押しても発光しない場合、バーコードリーダーが故障している恐れがあります。

発光する場合には、下記のバーコードを ① → ② → ③ の順で読み取り、ミシンを再起動してください。

①	 Z Z	設定開始
②	 U 2	初期化
③	 Z Z	設定終了

***ENGLISH***

***ENGLISH***

# CONTENTS

- 1. Installation procedure..... 1
- 2. Attaching the bar code ..... 2
- 3. Bar code function..... 2
- 4. Setting of the bar code function ..... 3
- 5. How to use ..... 4
- 6. Bar code configuration..... 5
- 7. Malfunction of the bar code reader ..... 6

**CAUTION :**

Turn OFF the power before starting the work so as to prevent accidents caused by abrupt start of the sewing machine.

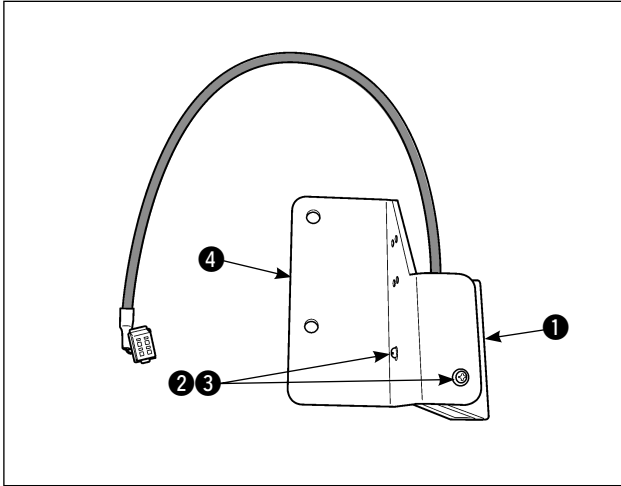
**1. Installation procedure**

- 1) Install the bar code reader **1** onto the mounting plate **4** using the screws **2** and the washers **3** (two locations) which are included as the accessories.

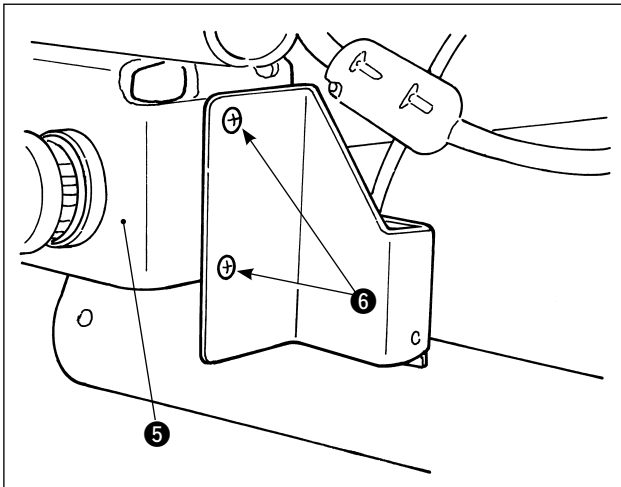

- 2) Fix the mounting plate on temporary stop switch **5** with setscrews **6** supplied with the mounting plate as accessories.

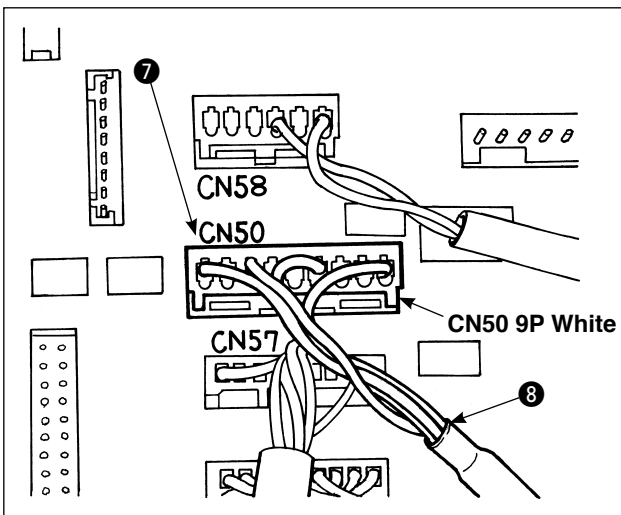

- 3) Open the electrical box, and connect the relay cable **8** to CN50 **7** of the main PCB.

**WARNING :**

- Do not look directly into the laser beam of the bar code reader. The laser beam can damage eyes.
- Do not emit laser beam toward human eyes. The laser beam can damage eyes.
- Do not look into the laser beam directly using an optical device. The laser beam can damage eyes.

**CAUTION :**

- Be sure to use the sewing machine within the specified temperature range and the specified humidity range.
- Do not connect/remove connectors with the power supplied to the sewing machine.

## 2. Attaching the bar code

Copy the bar code attached at the end of the instruction manual for use.

## 3. Bar code function

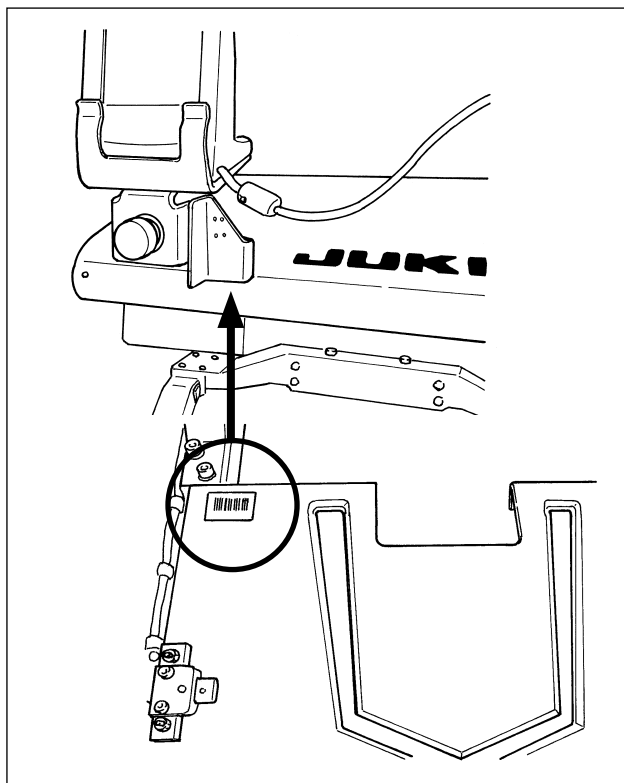

Bar code function is a function to read the bar code and to switch to the corresponding sewing pattern for the applications such as the cassette identification etc.

By reading the bar code, switching to 999 user patterns stored in the sewing machine memory and to 50 sewing data registered in the pattern button can be made.

To use this function, AP-876 bar code option will be required.

**Specifications for the barcode reader**

Class 2 laser product

Maximum output: 1.0mW

Wave length: 650nm

Safety standard

JIS C 6802:2005



IEC60825-1+A2:2007

## 4. Setting of the bar code function

### 4-1. Setting of the bar code function

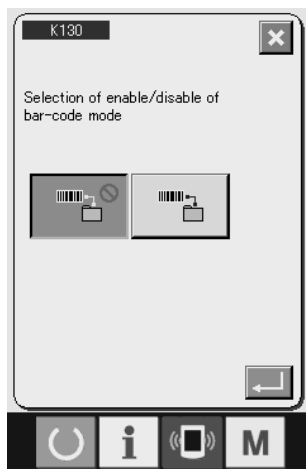
On memory switch K130, select the bar code mode. Refer to the engineer's manual for the selection method of the memory switch K130 (level 2).





Setting	Content	Explanation
	Standard mode	Bar code is not used.
	Bar code mode	Bar code is used.

### 4-2. Selection of the bar code type

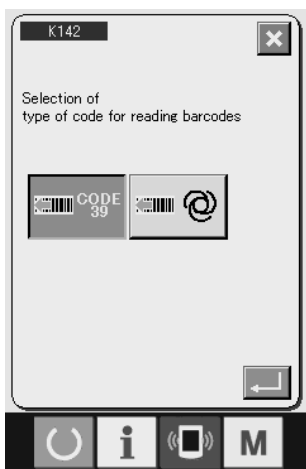
On memory switch K142, a type of bar code is selected. In the default state, Code39 only will be read. When the attached bar code is printed for use, the change to K142 will not be required.



Setting	Content	Explanation
	Code39	Code39 only will be read.
	All standards.	All standards that the bar code reader is compatible to will be read. JAN, EAN, UPC-A/E, EAN-8/13 Add-on, UPC-A/E Add-on, Industrial 2 of 5, IATA, Interleaved 2 of 5, NW-7(Codabar), Code39, Code93, Code128, EAN-128, S-Code, MSI/Plessey, RSS, Tri-Optic, CODE11, UK/Plessey, Matrix 2 of 5, Chinese Post Matrix 2 of 5, TELEPEN

## 5. How to use

Pattern number reading by means of the bar code is "only enabled under the pattern replacement mode".

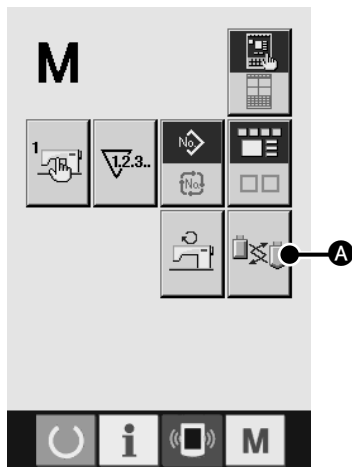

### 1) Activating the pattern change mode

When the MODE key **M** is pressed, the pattern change mode button  **A** is displayed on the screen. When this button is pressed, the pattern change mode screen is displayed.

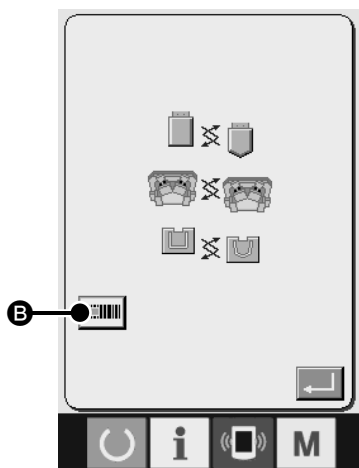

Pattern replacement mode screen



### 2) Under the bar code mode, bar code mode display **B**

is shown on the screen.

Only when the pattern replacement mode screen is displayed, the scanning laser is emitted from the bar code reader to enable reading of the bar code.

Once the bar code is scanned properly, the scanning laser from the bar code reader stops.

### List of error codes

Error code	Pictograph	Error content	Displayed message	How to recover	Place of recovery
E010		The pattern designated by bar code is not registered.	Designated pattern does not exist.	Possible to re-start after reset.	Previous screen
E058		There is no bar code at the reading position. Bar code decoding failed. Communication time out.	Bar code reading error	Possible to re-start after reset.	Previous screen
E921		Bar code reader is not connected to the sewing machine. Bar code format error.	Bar code reader communication error	Turn OFF the power	



## 6. Bar code configuration

By reading the bar code sheet attached at the end of this manual, the sewing pattern can be switched to the one corresponding to the selected bar code. Separate the attached bar code sheet for your use. This bar code sheet is compatible to Code39.

When creating bar codes to a standard other than Code39, create the codes according to the following format.

- 4 byte ASCII code
- “Pattern type”, “hundreds place”, “tens place”, “ones place”

Example

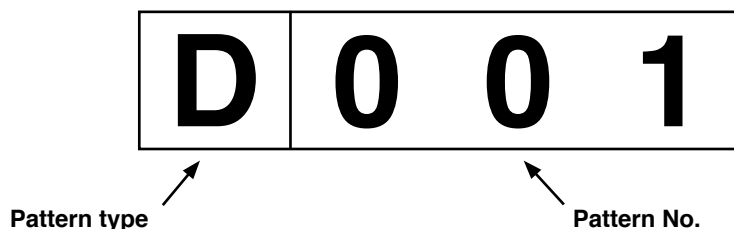

### Pattern type

U or 0 : Corresponds to the user patterns

D or 1 : Corresponds to the sewing data registered in the pattern button

### Pattern No.

User pattern : No. 001 to No. 999

Sewing data registered in the pattern button : No. 001 to No. 050

Both the pattern type and the numbers shall be written in ASCII code.

In the case of D001 as shown above, it will be described as 0x44 0x30 0x30 0x31.

Start/stop character etc. shall be created according to the bar code standard used.



**If the margin at both sides of the bar code is small, there is a possibility of reading error.**

**Therefore, try to have as much margin as possible on both sides.** If the bar codes at the end of this manual are used, make a copy of the sheet, and then cut along the dotted lines.

## 7. Malfunction of the bar code reader

When the bar code reader does not work, push the SCAN button on the side of the bar code reader to check if there is laser emission or not.

If there is no laser emission even if the SCAN button is pushed, the bar code reader may be defective. If the laser is emitted, read the following bar codes in the order of ① → ② → ③, and restart the sewing machine.

①	 Z Z	Start of setting
②	 U 2	Initialization
③	 Z Z	End of setting

中文

中文

# 目 录

1. 安装顺序 .....	1
2. 条形码的粘贴 .....	2
3. 关于条形码功能 .....	2
4. 条形码功能的设定 .....	3
5. 使用方法 .....	4
6. 条形码的构成 .....	5
7. 关于条形码阅读器的动作故障 .....	6

# ⚠ 注意

为了防止突然的启动造成的事故，请一定关掉电源之后再进行操作。

## 1. 安装顺序

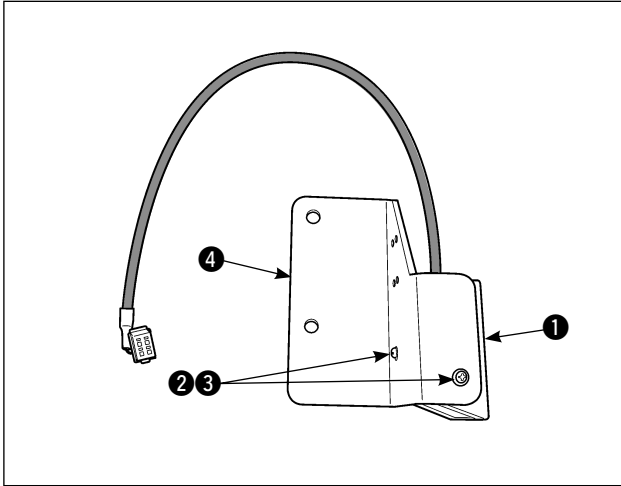

- 1) 用附属的螺丝 ②、垫片 ③ 把条形码阅读器 ① 安装到安装板 ④ 上。  
(2 处)

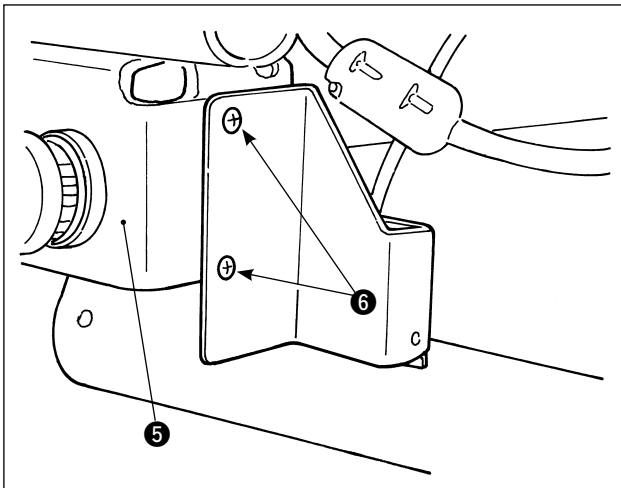

- 2) 用附属的安装板固定螺丝 ⑥ 固定到暂停开关 ⑤ 上。

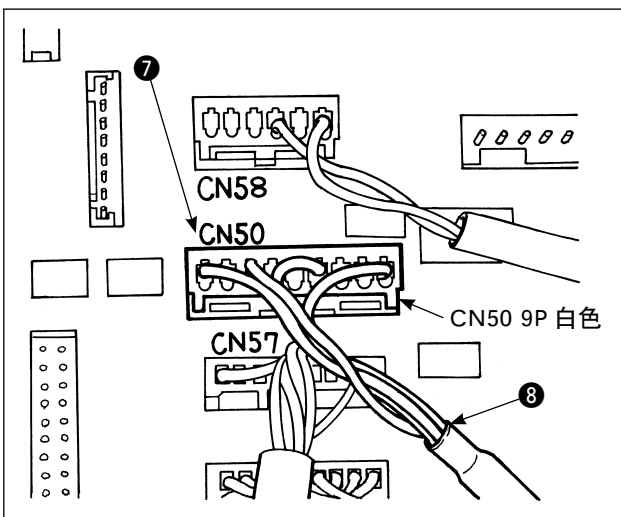

- 3) 打开电气箱，  
把连接电缆 ⑧ 连接到 MAIN 电路板的 CN50 ⑦ 上。



## 警告

- 请不要直接用眼睛去看条码阅读器的激光光线。有可能伤害眼睛。
- 请不要对着人的眼睛放射激光。有可能伤害眼睛。
- 请不要用光学仪器直接窥看激光光线。有可能伤害眼睛。



## 注意

- 请在缝纫机的使用温度范围内以及使用湿度内使用。
- 在供给了电源的状态下，请不要拔插连接器。

## 2. 条形码的粘贴

请复印使用说明书的卷末附录的条形码供下面操作使用。

## 3. 关于条形码功能

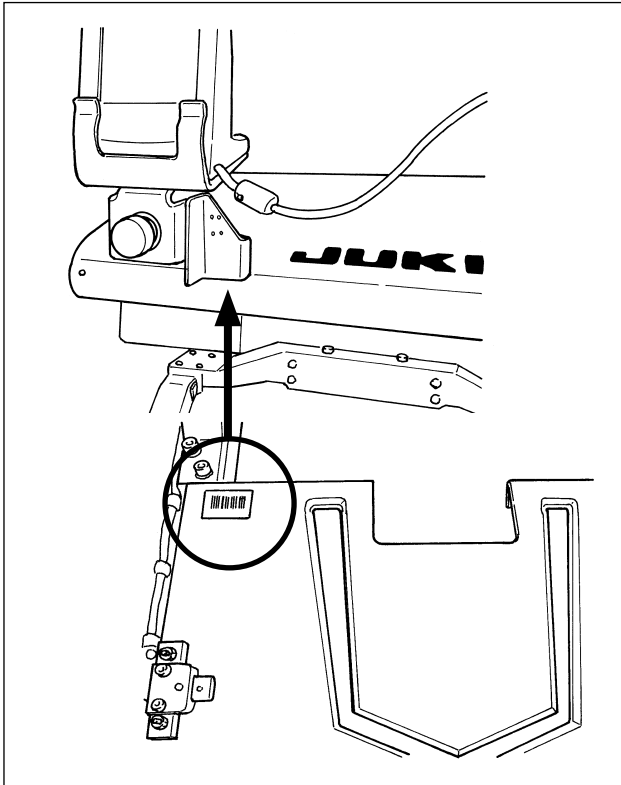

所谓条形码功能就是在用于识别卡盒等时，阅读条形码，变换成对应的缝制图案进行缝制的功能。通过阅读条形码，可以变换保存在缝纫机存储器内的 999 个用户图案、50 个等级在图案按钮中的缝制数据。

使用本功能时、需要 AP-876 条形码选购项目机器。

### 条形码阅读器规格

2 级 激光产品

最大输出：1.0mW

波长：650nm

### 安全规格

JIS C 6802:2005



IEC60825-1+A2:2007

## 4. 条形码功能的设定

### 4-1. 条形码功能的设定

用存储器开关 K130 选择条形码模式。有关存储器开关 K130(等级 2) 的选择方法, 请参照服务手册。





设定	内容	说明
	标准模式	不使用条形码。
	条形码模式	使用条形码。

### 4-2. 条形码种类的选择

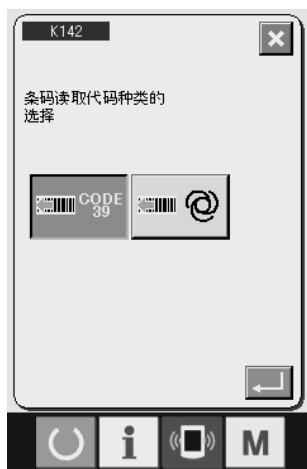
用存储器开关 K142 选择条形码种类。初期状态时, 仅读取 Code39。印刷附录的条形码后使用时, 不需要变更 K142。



设定	内容	说明
	Code39	仅读取 Code39。
	全规格	读取对应条形码阅读器的全规格。 JAN、EAN、UPC-A/E、 EAN-8/13 Add-on、UPC-A/E Add-on、Industrial2of5、IATA、 Interleaved2of5、NW-7(Codabar)、 Code39、Code93、Code128、 EAN-128、S-Code、MSI/Plessey、 RSS、Tri-Optic、CODE11、UK/ Plessey、Matrix 2of5、Chinese Post Matrix 2of5、TELEPEN

## 5. 使用方法

用条形码读取缝制图案花样 No. 的动作「仅在型更换模式时有效」。

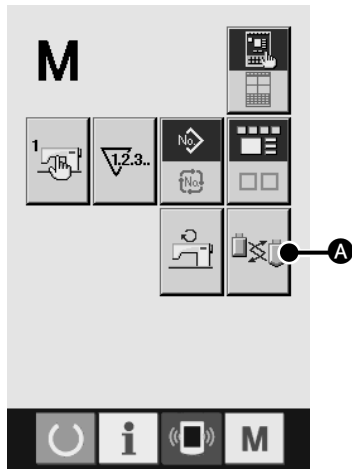

### 1) 型更换模式的起动

按了模式键 **M** 之后，在画面上显示出型更换模式按键

 **A**。按了此键之后，型更换模式画面被显示出来。

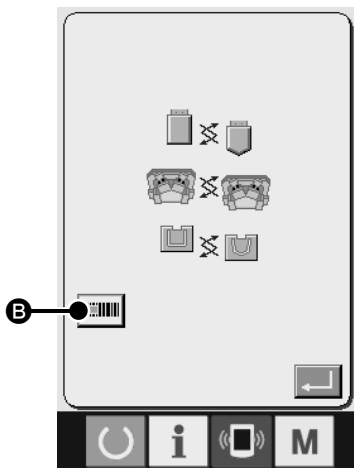



型更换模式画面

### 2) 条形码模式时，条形码模式显示 **B** 被显示到画面上。

仅在显示着型更换模式画面时，条形码阅读器发出读取激光，可以读取条形码。

正常地读取了条形码之后，读取激光就从条形码阅读器上消失。

### 异常代码一览

异常代码	图标	异常内容	显示信息	复位方法	复位位置
E010		条形码规定的图案备由被登记。	没有规定的图案。	复位后可以重新输入	前画面
E058		在读取位置上没有条形码。 条形码的解码失败。 通信超时	条形码读取异常	复位后可以重新输入	前画面
E921		条形码阅读器没有连接到缝纫机上。 条形码的格式化异常	条形码阅读器通信异常	电源 OFF	



## 6. 条形码的构成

读取卷末附录中的条形码表，可以变换成对应的缝制图案。请剪下来使用。条形码表对应 Code39 的规格。

Code39 以外规格编制的条形码时，请按照下列格式进行编制。

- 4 比特 ASCII 代码
- “图案种类”、“百位”、“十位”、“个位”

ex.

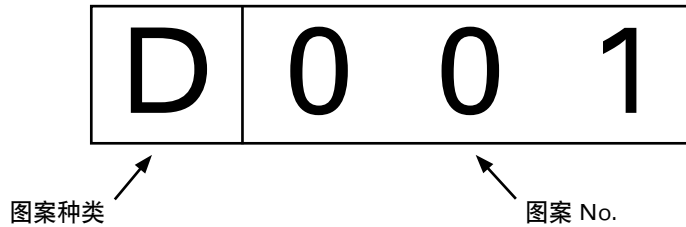

### 图案种类

U 或 0：对应用户图案。

D 或 1：对应图案按钮中登记的缝制数据。

### 图案 No.

用户图案：No.001 ~ No.999

图案按钮中登记的缝制数据：No.001 ~ No.050

请用 ASCII 代码记述种类、No. 等。

上述 D001 时为 0x44 0x30 0x30 0x31。

对于开始 / 停止字符等，请按照使用的条形码规格进行编制。

如果条形码两侧的空白小的话，有可能发生读取异常。因此，请把两侧的空白尽可能留得大一点。使用卷末附录中的条形码时，请先复印然后沿着虚线剪下来使用。

## 7. 关于条形码阅读器的动作故障

如果条形码阅读器不能进行读取时，请按条形码阅读器侧面的 SCAN 按钮，确认激光是否发光。

按了 SCAN 按钮也不发光时，有可能是条形码阅读器出了故障。

发光时，请按照 ① → ② → ③ 的顺序读取下列的条形码，然后重新启动缝纫机。

①	 Z Z	开始设定
②	 U 2	初期化
③	 Z Z	设定结束

# ***BARCODE SHEET***



両サイドの余白が小さいと、読取り不良の原因になります。切り取り線に沿って切り離してください。

If the margin on both sides of the bar code is small, it may cause a reading error.

Cut the bar codes along the dotted lines.



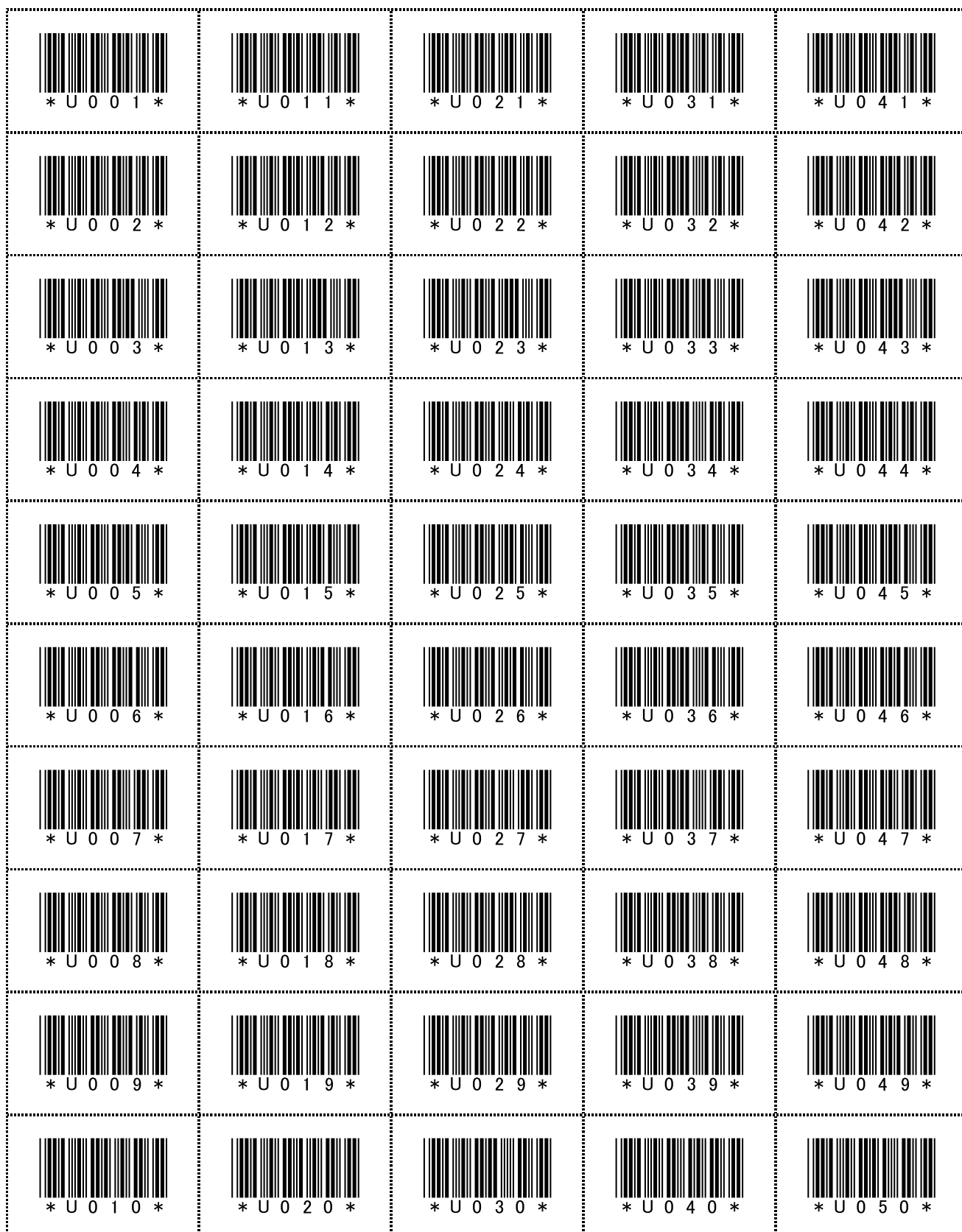



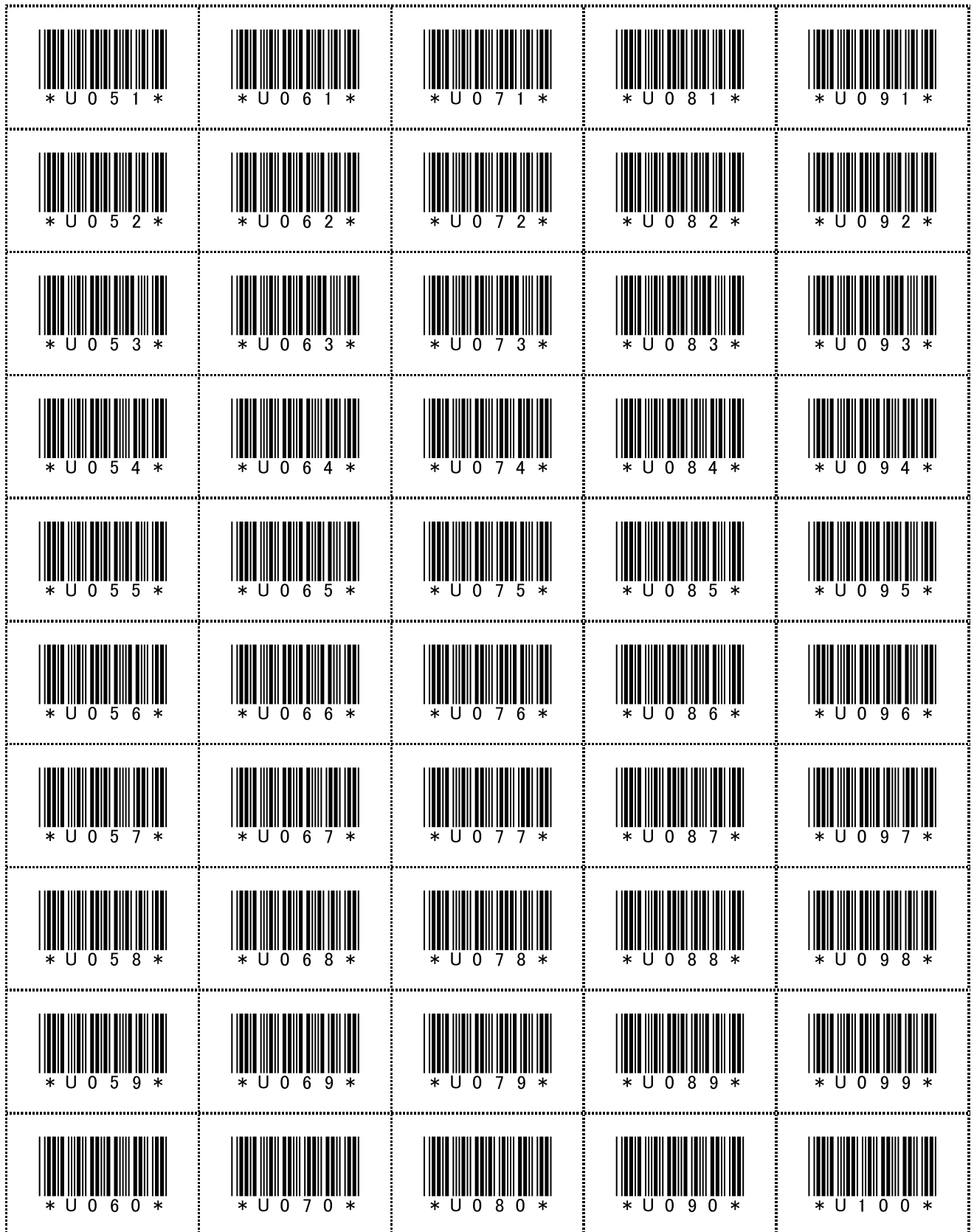











































如果条形码两侧的空白小的话，有可能发生读取异常。请沿着虚线剪下来使用。



ユーザーパターン No. 001 ~ 050 / User pattern No. 001 to 050. / 用户图案 No.001 ~ No.050



ユーザーパターン No. 051 ~ 100 / User pattern No. 051 to 100. / 用户图案 No.051 ~ No.100





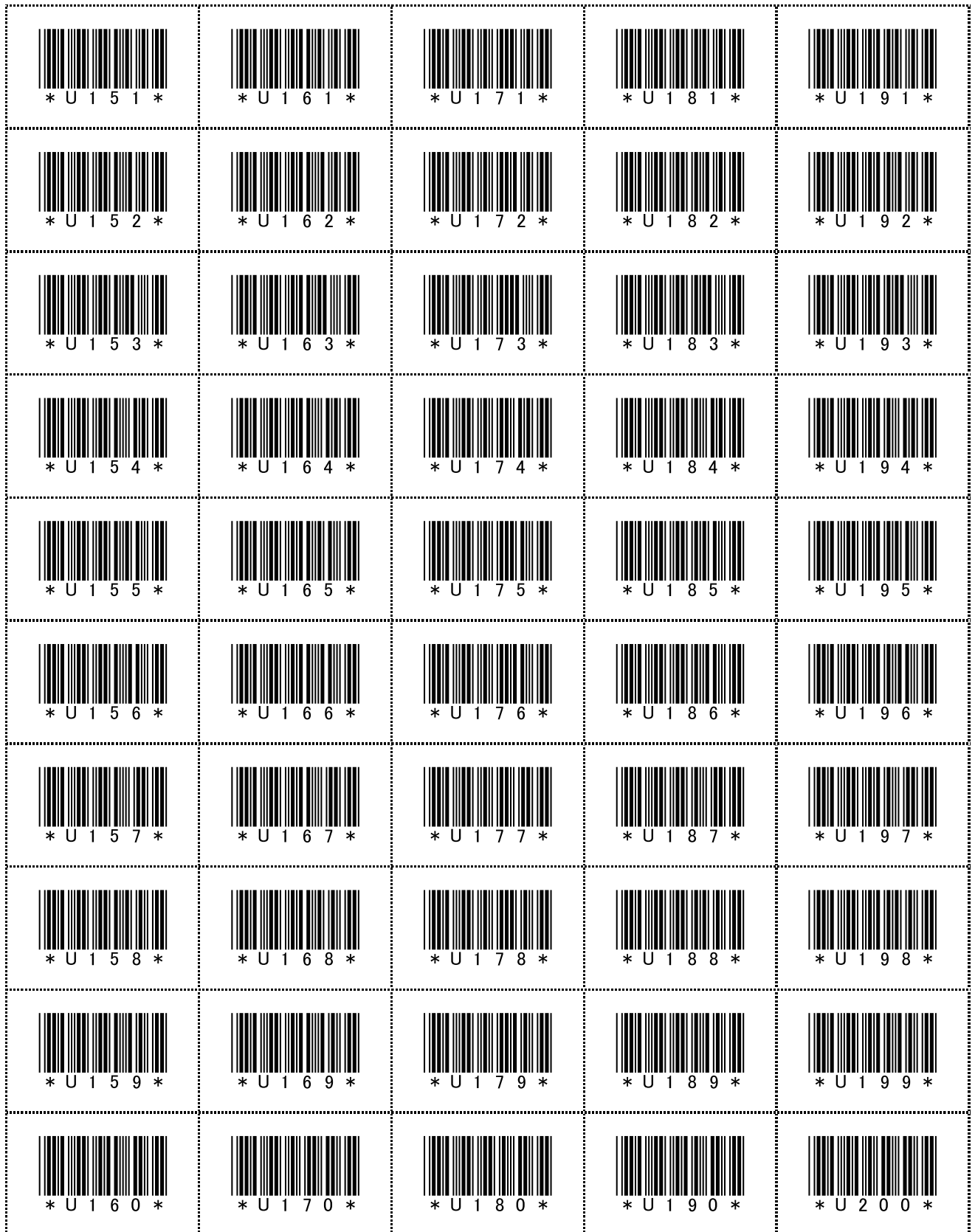





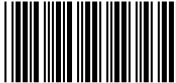





































 * U 1 0 1 *	 * U 1 1 1 *	 * U 1 2 1 *	 * U 1 3 1 *	 * U 1 4 1 *
 * U 1 0 2 *	 * U 1 1 2 *	 * U 1 2 2 *	 * U 1 3 2 *	 * U 1 4 2 *
 * U 1 0 3 *	 * U 1 1 3 *	 * U 1 2 3 *	 * U 1 3 3 *	 * U 1 4 3 *
 * U 1 0 4 *	 * U 1 1 4 *	 * U 1 2 4 *	 * U 1 3 4 *	 * U 1 4 4 *
 * U 1 0 5 *	 * U 1 1 5 *	 * U 1 2 5 *	 * U 1 3 5 *	 * U 1 4 5 *
 * U 1 0 6 *	 * U 1 1 6 *	 * U 1 2 6 *	 * U 1 3 6 *	 * U 1 4 6 *
 * U 1 0 7 *	 * U 1 1 7 *	 * U 1 2 7 *	 * U 1 3 7 *	 * U 1 4 7 *
 * U 1 0 8 *	 * U 1 1 8 *	 * U 1 2 8 *	 * U 1 3 8 *	 * U 1 4 8 *
 * U 1 0 9 *	 * U 1 1 9 *	 * U 1 2 9 *	 * U 1 3 9 *	 * U 1 4 9 *
 * U 1 1 0 *	 * U 1 2 0 *	 * U 1 3 0 *	 * U 1 4 0 *	 * U 1 5 0 *

ユーザーパターン No. 101 ~ 150 / User pattern No. 101 to 150. / 用户图案 No.101 ~ No.150



ユーザーパターン No. 151 ~ 200 / User pattern No. 151 to 200. / 用户图案 No.151 ~ No.200







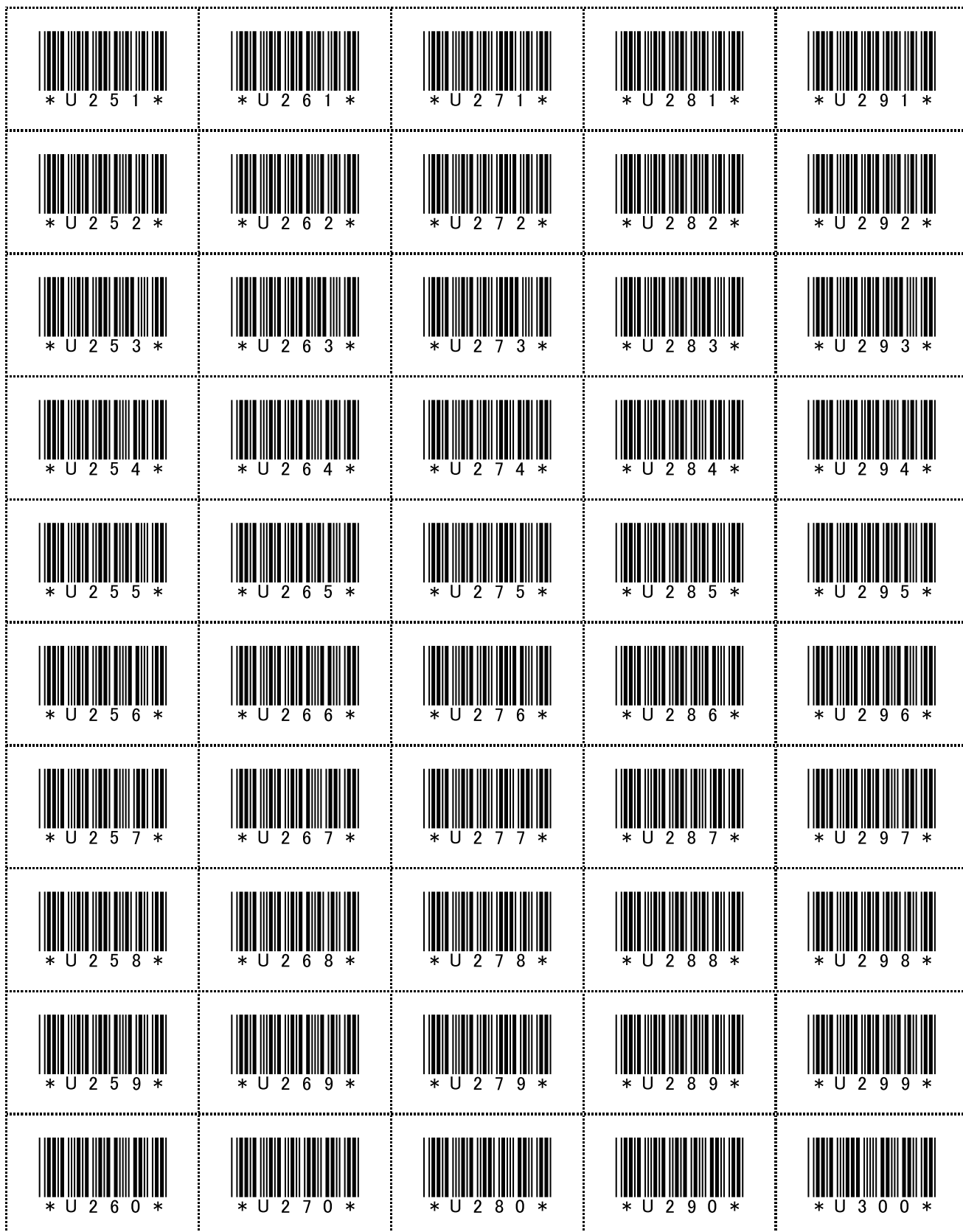



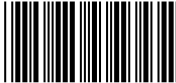

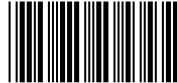







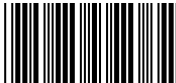



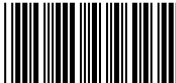

























 * U 2 0 1 *	 * U 2 1 1 *	 * U 2 2 1 *	 * U 2 3 1 *	 * U 2 4 1 *
 * U 2 0 2 *	 * U 2 1 2 *	 * U 2 2 2 *	 * U 2 3 2 *	 * U 2 4 2 *
 * U 2 0 3 *	 * U 2 1 3 *	 * U 2 2 3 *	 * U 2 3 3 *	 * U 2 4 3 *
 * U 2 0 4 *	 * U 2 1 4 *	 * U 2 2 4 *	 * U 2 3 4 *	 * U 2 4 4 *
 * U 2 0 5 *	 * U 2 1 5 *	 * U 2 2 5 *	 * U 2 3 5 *	 * U 2 4 5 *
 * U 2 0 6 *	 * U 2 1 6 *	 * U 2 2 6 *	 * U 2 3 6 *	 * U 2 4 6 *
 * U 2 0 7 *	 * U 2 1 7 *	 * U 2 2 7 *	 * U 2 3 7 *	 * U 2 4 7 *
 * U 2 0 8 *	 * U 2 1 8 *	 * U 2 2 8 *	 * U 2 3 8 *	 * U 2 4 8 *
 * U 2 0 9 *	 * U 2 1 9 *	 * U 2 2 9 *	 * U 2 3 9 *	 * U 2 4 9 *
 * U 2 1 0 *	 * U 2 2 0 *	 * U 2 3 0 *	 * U 2 4 0 *	 * U 2 5 0 *

ユーザーパターン No. 201 ~ 250 / User pattern No. 201 to 250. / 用户图案 No.201 ~ No.250









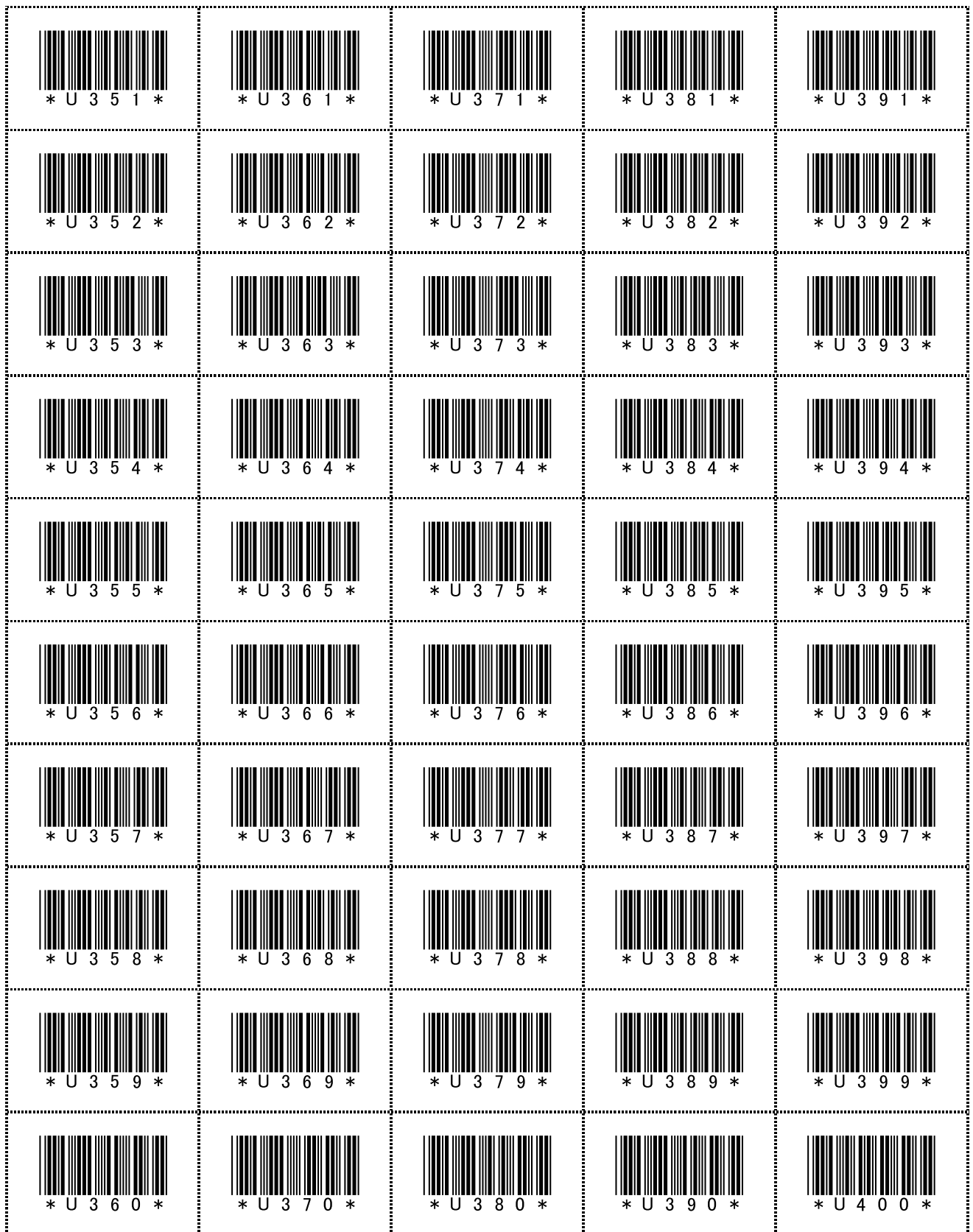











































ユーザーパターン No. 251 ~ 300 / User pattern No. 251 to 300. / 用户图案 No.251 ~ No.300

 * U 3 0 1 *	 * U 3 1 1 *	 * U 3 2 1 *	 * U 3 3 1 *	 * U 3 4 1 *
 * U 3 0 2 *	 * U 3 1 2 *	 * U 3 2 2 *	 * U 3 3 2 *	 * U 3 4 2 *
 * U 3 0 3 *	 * U 3 1 3 *	 * U 3 2 3 *	 * U 3 3 3 *	 * U 3 4 3 *
 * U 3 0 4 *	 * U 3 1 4 *	 * U 3 2 4 *	 * U 3 3 4 *	 * U 3 4 4 *
 * U 3 0 5 *	 * U 3 1 5 *	 * U 3 2 5 *	 * U 3 3 5 *	 * U 3 4 5 *
 * U 3 0 6 *	 * U 3 1 6 *	 * U 3 2 6 *	 * U 3 3 6 *	 * U 3 4 6 *
 * U 3 0 7 *	 * U 3 1 7 *	 * U 3 2 7 *	 * U 3 3 7 *	 * U 3 4 7 *
 * U 3 0 8 *	 * U 3 1 8 *	 * U 3 2 8 *	 * U 3 3 8 *	 * U 3 4 8 *
 * U 3 0 9 *	 * U 3 1 9 *	 * U 3 2 9 *	 * U 3 3 9 *	 * U 3 4 9 *
 * U 3 1 0 *	 * U 3 2 0 *	 * U 3 3 0 *	 * U 3 4 0 *	 * U 3 5 0 *

ユーザーパターン No. 301 ~ 350 / User pattern No. 301 to 350. / 用户图案 No.301 ~ No.350









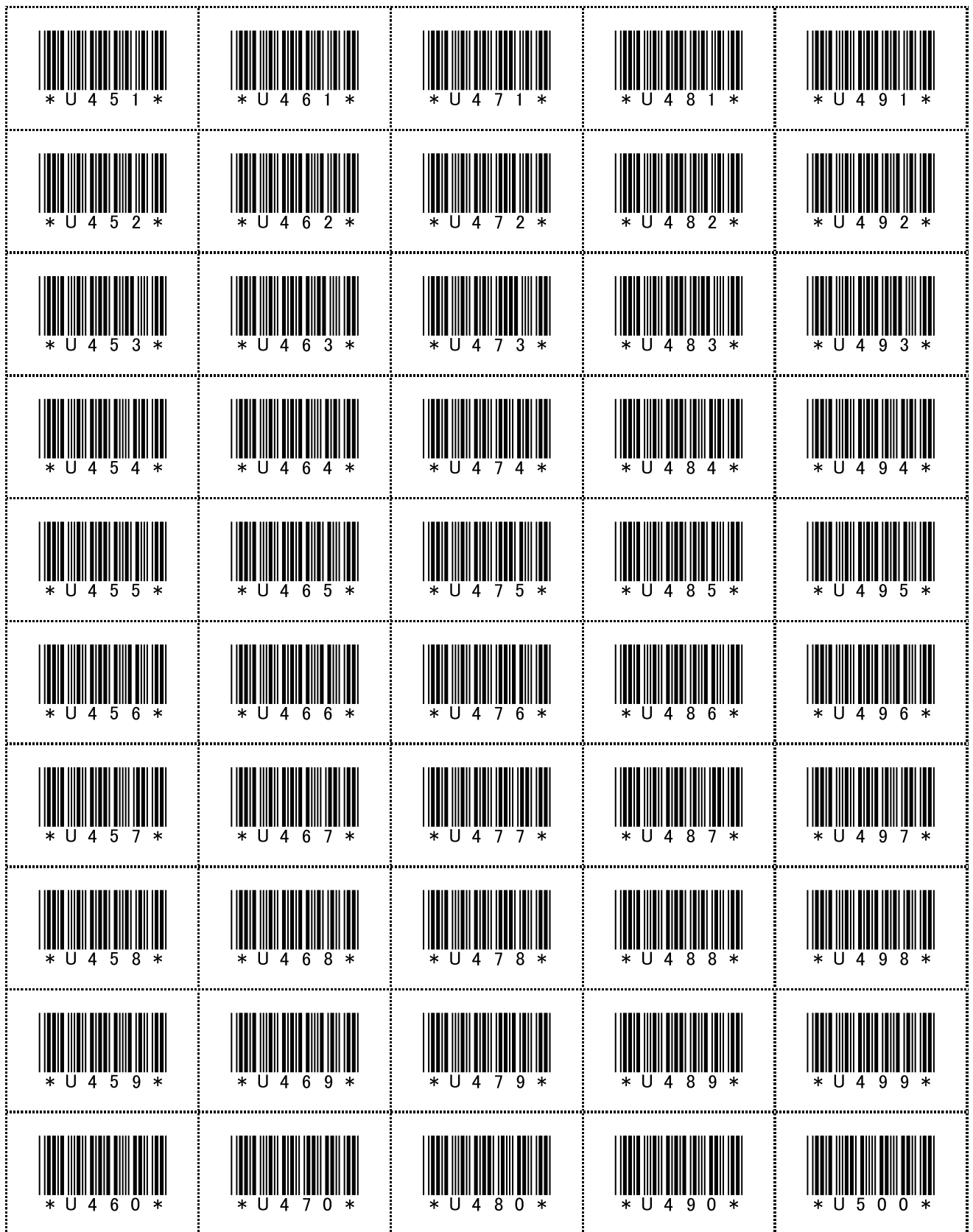











































ユーザーパターン No. 351 ~ 400 / User pattern No. 351 to 400. / 用户图案 No.351 ~ No.400

 * U 4 0 1 *	 * U 4 1 1 *	 * U 4 2 1 *	 * U 4 3 1 *	 * U 4 4 1 *
 * U 4 0 2 *	 * U 4 1 2 *	 * U 4 2 2 *	 * U 4 3 2 *	 * U 4 4 2 *
 * U 4 0 3 *	 * U 4 1 3 *	 * U 4 2 3 *	 * U 4 3 3 *	 * U 4 4 3 *
 * U 4 0 4 *	 * U 4 1 4 *	 * U 4 2 4 *	 * U 4 3 4 *	 * U 4 4 4 *
 * U 4 0 5 *	 * U 4 1 5 *	 * U 4 2 5 *	 * U 4 3 5 *	 * U 4 4 5 *
 * U 4 0 6 *	 * U 4 1 6 *	 * U 4 2 6 *	 * U 4 3 6 *	 * U 4 4 6 *
 * U 4 0 7 *	 * U 4 1 7 *	 * U 4 2 7 *	 * U 4 3 7 *	 * U 4 4 7 *
 * U 4 0 8 *	 * U 4 1 8 *	 * U 4 2 8 *	 * U 4 3 8 *	 * U 4 4 8 *
 * U 4 0 9 *	 * U 4 1 9 *	 * U 4 2 9 *	 * U 4 3 9 *	 * U 4 4 9 *
 * U 4 1 0 *	 * U 4 2 0 *	 * U 4 3 0 *	 * U 4 4 0 *	 * U 4 5 0 *

ユーザーパターン No. 401 ~ 450 / User pattern No. 401 to 450. / 用户图案 No.401 ~ No.450



ユーザーパターン No. 451 ~ 500 / User pattern No. 451 to 500. / 用户图案 No.451 ~ No.500





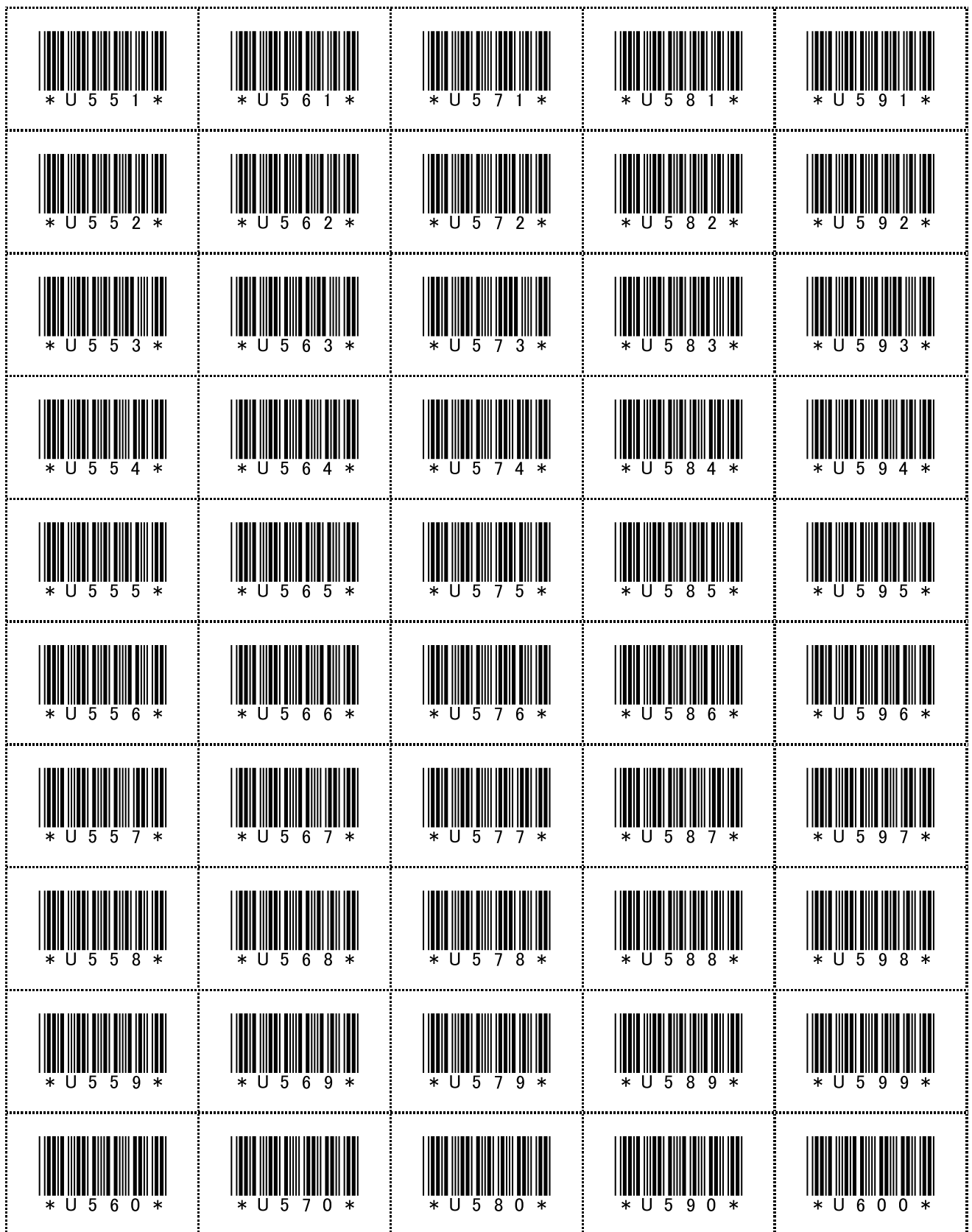





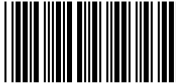

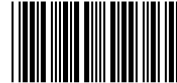



































 * U 5 0 1 *	 * U 5 1 1 *	 * U 5 2 1 *	 * U 5 3 1 *	 * U 5 4 1 *
 * U 5 0 2 *	 * U 5 1 2 *	 * U 5 2 2 *	 * U 5 3 2 *	 * U 5 4 2 *
 * U 5 0 3 *	 * U 5 1 3 *	 * U 5 2 3 *	 * U 5 3 3 *	 * U 5 4 3 *
 * U 5 0 4 *	 * U 5 1 4 *	 * U 5 2 4 *	 * U 5 3 4 *	 * U 5 4 4 *
 * U 5 0 5 *	 * U 5 1 5 *	 * U 5 2 5 *	 * U 5 3 5 *	 * U 5 4 5 *
 * U 5 0 6 *	 * U 5 1 6 *	 * U 5 2 6 *	 * U 5 3 6 *	 * U 5 4 6 *
 * U 5 0 7 *	 * U 5 1 7 *	 * U 5 2 7 *	 * U 5 3 7 *	 * U 5 4 7 *
 * U 5 0 8 *	 * U 5 1 8 *	 * U 5 2 8 *	 * U 5 3 8 *	 * U 5 4 8 *
 * U 5 0 9 *	 * U 5 1 9 *	 * U 5 2 9 *	 * U 5 3 9 *	 * U 5 4 9 *
 * U 5 1 0 *	 * U 5 2 0 *	 * U 5 3 0 *	 * U 5 4 0 *	 * U 5 5 0 *

ユーザーパターン No. 501 ~ 550 / User pattern No. 501 to 550. / 用户图案 No.501 ~ No.550



ユーザーパターン No. 551 ~ 600 / User pattern No. 551 to 600. / 用户图案 No.551 ~ No.600







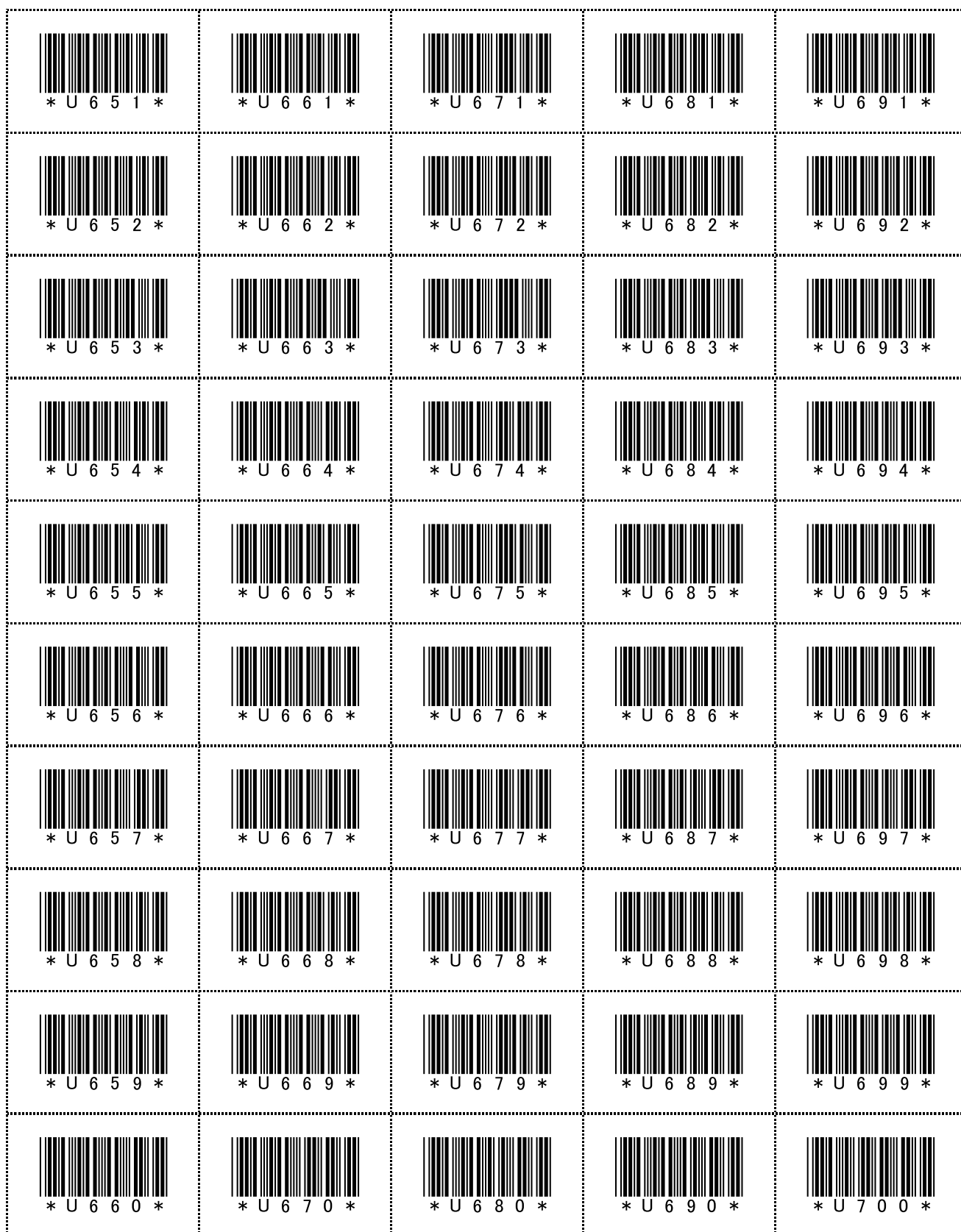













































 * U 6 0 1 *	 * U 6 1 1 *	 * U 6 2 1 *	 * U 6 3 1 *	 * U 6 4 1 *
 * U 6 0 2 *	 * U 6 1 2 *	 * U 6 2 2 *	 * U 6 3 2 *	 * U 6 4 2 *
 * U 6 0 3 *	 * U 6 1 3 *	 * U 6 2 3 *	 * U 6 3 3 *	 * U 6 4 3 *
 * U 6 0 4 *	 * U 6 1 4 *	 * U 6 2 4 *	 * U 6 3 4 *	 * U 6 4 4 *
 * U 6 0 5 *	 * U 6 1 5 *	 * U 6 2 5 *	 * U 6 3 5 *	 * U 6 4 5 *
 * U 6 0 6 *	 * U 6 1 6 *	 * U 6 2 6 *	 * U 6 3 6 *	 * U 6 4 6 *
 * U 6 0 7 *	 * U 6 1 7 *	 * U 6 2 7 *	 * U 6 3 7 *	 * U 6 4 7 *
 * U 6 0 8 *	 * U 6 1 8 *	 * U 6 2 8 *	 * U 6 3 8 *	 * U 6 4 8 *
 * U 6 0 9 *	 * U 6 1 9 *	 * U 6 2 9 *	 * U 6 3 9 *	 * U 6 4 9 *
 * U 6 1 0 *	 * U 6 2 0 *	 * U 6 3 0 *	 * U 6 4 0 *	 * U 6 5 0 *

ユーザーパターン No. 601 ~ 650 / User pattern No. 601 to 650. / 用户图案 No.601 ~ No.650









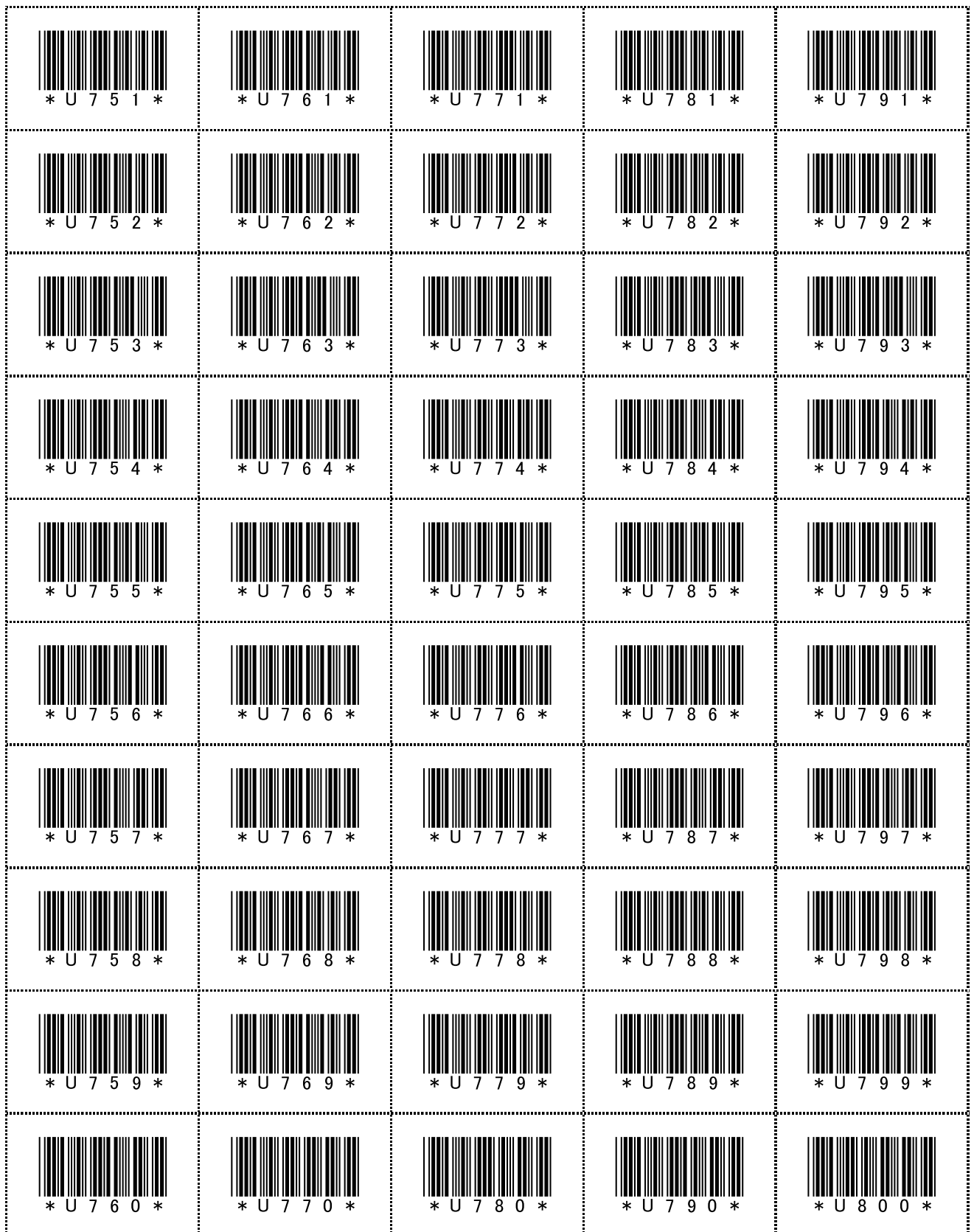











































ユーザーパターン No. 651 ~ 700 / User pattern No. 651 to 700. / 用户图案 No.651 ~ No.700

 * U 7 0 1 *	 * U 7 1 1 *	 * U 7 2 1 *	 * U 7 3 1 *	 * U 7 4 1 *
 * U 7 0 2 *	 * U 7 1 2 *	 * U 7 2 2 *	 * U 7 3 2 *	 * U 7 4 2 *
 * U 7 0 3 *	 * U 7 1 3 *	 * U 7 2 3 *	 * U 7 3 3 *	 * U 7 4 3 *
 * U 7 0 4 *	 * U 7 1 4 *	 * U 7 2 4 *	 * U 7 3 4 *	 * U 7 4 4 *
 * U 7 0 5 *	 * U 7 1 5 *	 * U 7 2 5 *	 * U 7 3 5 *	 * U 7 4 5 *
 * U 7 0 6 *	 * U 7 1 6 *	 * U 7 2 6 *	 * U 7 3 6 *	 * U 7 4 6 *
 * U 7 0 7 *	 * U 7 1 7 *	 * U 7 2 7 *	 * U 7 3 7 *	 * U 7 4 7 *
 * U 7 0 8 *	 * U 7 1 8 *	 * U 7 2 8 *	 * U 7 3 8 *	 * U 7 4 8 *
 * U 7 0 9 *	 * U 7 1 9 *	 * U 7 2 9 *	 * U 7 3 9 *	 * U 7 4 9 *
 * U 7 1 0 *	 * U 7 2 0 *	 * U 7 3 0 *	 * U 7 4 0 *	 * U 7 5 0 *

ユーザーパターン No. 701 ~ 750 / User pattern No. 701 to 750. / 用户图案 No.701 ~ No.750









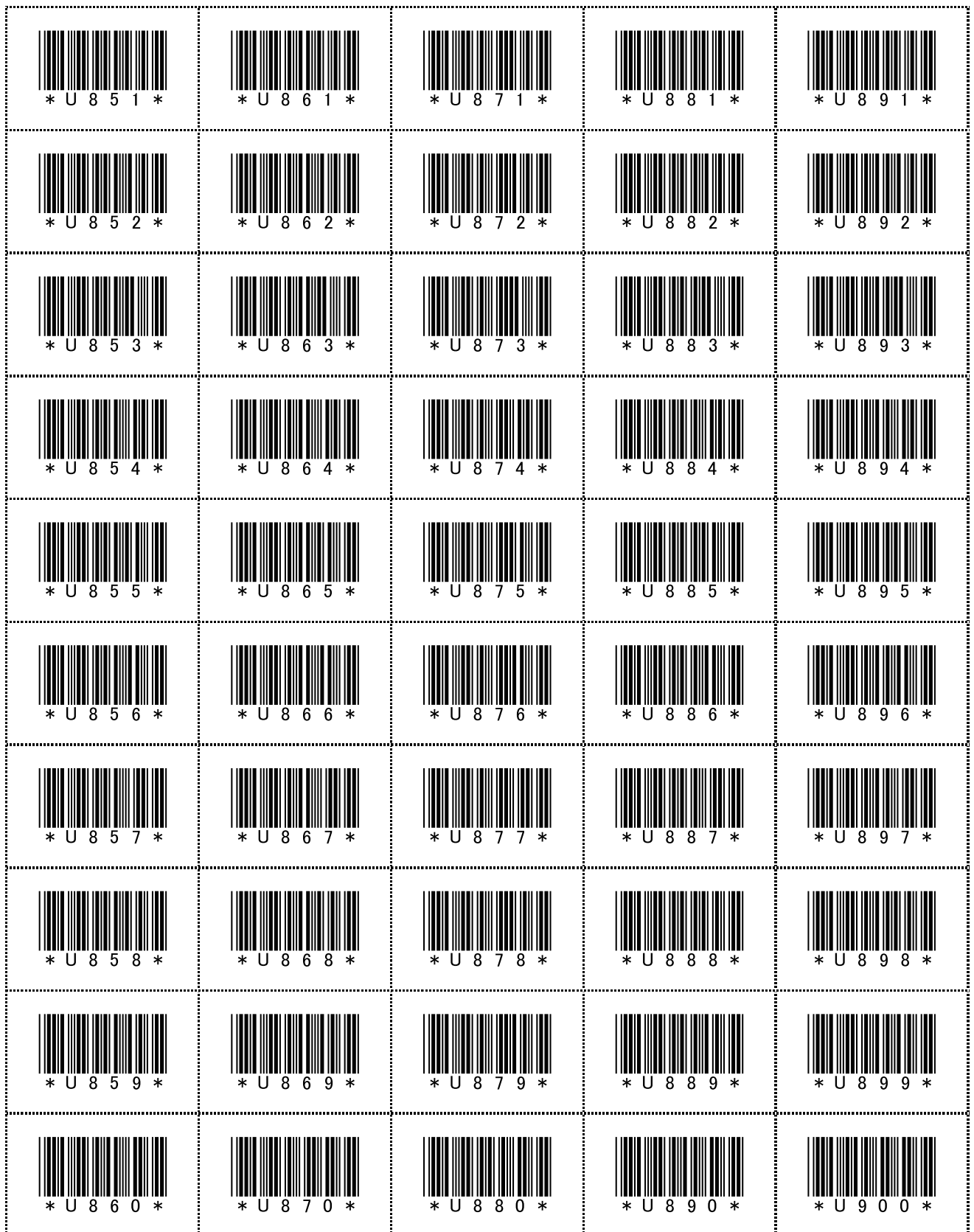











































ユーザーパターン No. 751 ~ 800 / User pattern No. 751 to 800. / 用户图案 No.751 ~ No.800

 * U 8 0 1 *	 * U 8 1 1 *	 * U 8 2 1 *	 * U 8 3 1 *	 * U 8 4 1 *
 * U 8 0 2 *	 * U 8 1 2 *	 * U 8 2 2 *	 * U 8 3 2 *	 * U 8 4 2 *
 * U 8 0 3 *	 * U 8 1 3 *	 * U 8 2 3 *	 * U 8 3 3 *	 * U 8 4 3 *
 * U 8 0 4 *	 * U 8 1 4 *	 * U 8 2 4 *	 * U 8 3 4 *	 * U 8 4 4 *
 * U 8 0 5 *	 * U 8 1 5 *	 * U 8 2 5 *	 * U 8 3 5 *	 * U 8 4 5 *
 * U 8 0 6 *	 * U 8 1 6 *	 * U 8 2 6 *	 * U 8 3 6 *	 * U 8 4 6 *
 * U 8 0 7 *	 * U 8 1 7 *	 * U 8 2 7 *	 * U 8 3 7 *	 * U 8 4 7 *
 * U 8 0 8 *	 * U 8 1 8 *	 * U 8 2 8 *	 * U 8 3 8 *	 * U 8 4 8 *
 * U 8 0 9 *	 * U 8 1 9 *	 * U 8 2 9 *	 * U 8 3 9 *	 * U 8 4 9 *
 * U 8 1 0 *	 * U 8 2 0 *	 * U 8 3 0 *	 * U 8 4 0 *	 * U 8 5 0 *

ユーザーパターン No. 801 ~ 850 / User pattern No. 801 to 850. / 用户图案 No.801 ~ No.850



ユーザーパターン No. 851 ~ 900 / User pattern No. 851 to 900. / 用户图案 No.851 ~ No.900





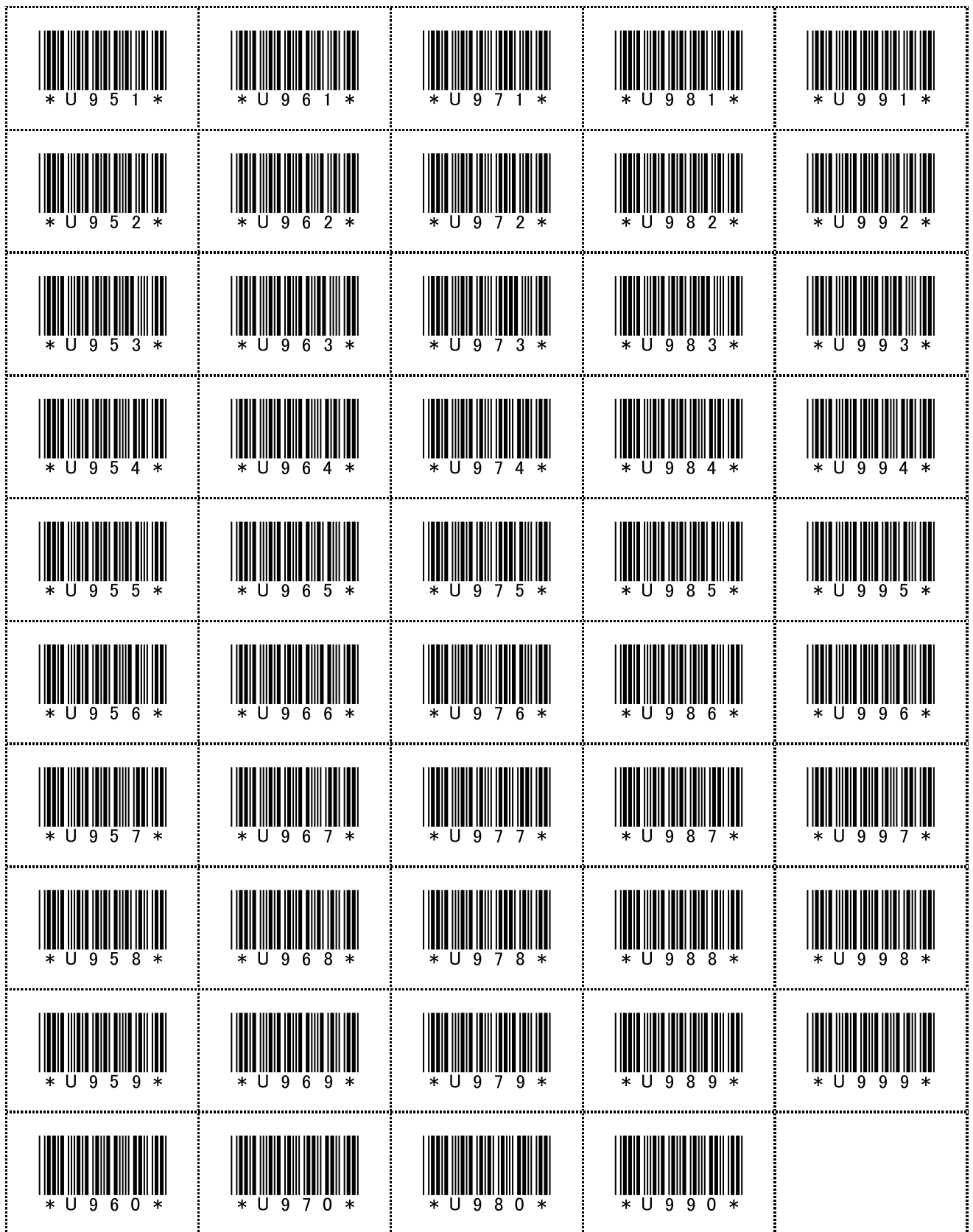













































 * U 9 0 1 *	 * U 9 1 1 *	 * U 9 2 1 *	 * U 9 3 1 *	 * U 9 4 1 *
 * U 9 0 2 *	 * U 9 1 2 *	 * U 9 2 2 *	 * U 9 3 2 *	 * U 9 4 2 *
 * U 9 0 3 *	 * U 9 1 3 *	 * U 9 2 3 *	 * U 9 3 3 *	 * U 9 4 3 *
 * U 9 0 4 *	 * U 9 1 4 *	 * U 9 2 4 *	 * U 9 3 4 *	 * U 9 4 4 *
 * U 9 0 5 *	 * U 9 1 5 *	 * U 9 2 5 *	 * U 9 3 5 *	 * U 9 4 5 *
 * U 9 0 6 *	 * U 9 1 6 *	 * U 9 2 6 *	 * U 9 3 6 *	 * U 9 4 6 *
 * U 9 0 7 *	 * U 9 1 7 *	 * U 9 2 7 *	 * U 9 3 7 *	 * U 9 4 7 *
 * U 9 0 8 *	 * U 9 1 8 *	 * U 9 2 8 *	 * U 9 3 8 *	 * U 9 4 8 *
 * U 9 0 9 *	 * U 9 1 9 *	 * U 9 2 9 *	 * U 9 3 9 *	 * U 9 4 9 *
 * U 9 1 0 *	 * U 9 2 0 *	 * U 9 3 0 *	 * U 9 4 0 *	 * U 9 5 0 *

ユーザーパターン No. 901 ~ 950 / User pattern No. 901 to 950. / 用户图案 No.901 ~ No.950



ユーザーパターン No. 951 ~ 999 / User pattern No. 951 to 999. / 用户图案 No.951 ~ No.999



 * D 0 0 1 *	 * D 0 1 1 *	 * D 0 2 1 *	 * D 0 3 1 *	 * D 0 4 1 *
 * D 0 0 2 *	 * D 0 1 2 *	 * D 0 2 2 *	 * D 0 3 2 *	 * D 0 4 2 *
 * D 0 0 3 *	 * D 0 1 3 *	 * D 0 2 3 *	 * D 0 3 3 *	 * D 0 4 3 *
 * D 0 0 4 *	 * D 0 1 4 *	 * D 0 2 4 *	 * D 0 3 4 *	 * D 0 4 4 *
 * D 0 0 5 *	 * D 0 1 5 *	 * D 0 2 5 *	 * D 0 3 5 *	 * D 0 4 5 *
 * D 0 0 6 *	 * D 0 1 6 *	 * D 0 2 6 *	 * D 0 3 6 *	 * D 0 4 6 *
 * D 0 0 7 *	 * D 0 1 7 *	 * D 0 2 7 *	 * D 0 3 7 *	 * D 0 4 7 *
 * D 0 0 8 *	 * D 0 1 8 *	 * D 0 2 8 *	 * D 0 3 8 *	 * D 0 4 8 *
 * D 0 0 9 *	 * D 0 1 9 *	 * D 0 2 9 *	 * D 0 3 9 *	 * D 0 4 9 *
 * D 0 1 0 *	 * D 0 2 0 *	 * D 0 3 0 *	 * D 0 4 0 *	 * D 0 5 0 *

ダイレクトパターン No. 001 ~ 050 / Direct pattern No. 001 to 050. / 直接图案 No.001 ~ No.050





# JUKI®

## JUKI 株式会社

縫製機器ユニット

〒 206-8551 東京都多摩市鶴牧 2-11-1

TEL. 042-357-2371 (ダイヤルイン)

FAX. 042-357-2380

<http://www.juki.co.jp>

## JUKI CORPORATION

SEWING MACHINERY BUSINESS UNIT

2-11-1, TSURUMAKI, TAMA-SHI,

TOKYO, 206-8551, JAPAN

PHONE : (81)42-357-2371

FAX : (81)42-357-2380

<http://www.juki.com>

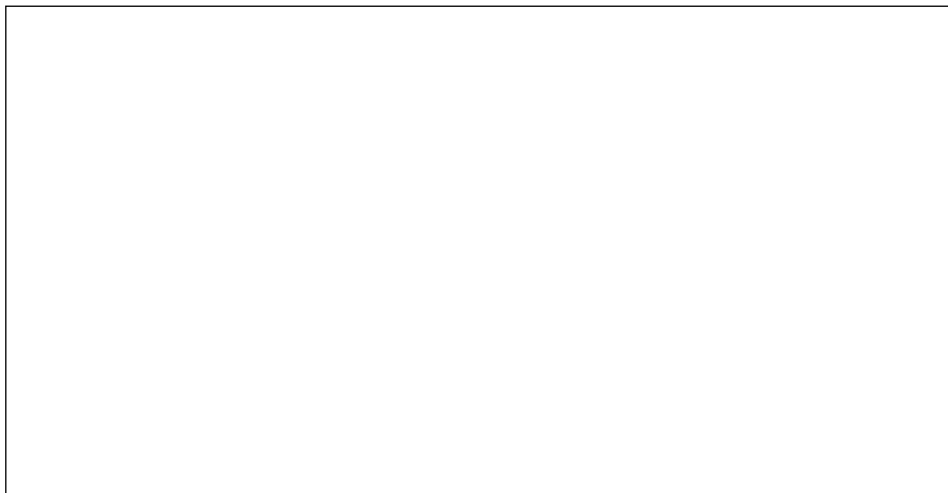

この製品の使い方について不明な点がありましたらお求めの販売店又は当社営業所にお問い合わせください。  
※この取扱説明書は仕様改良のため予告なく変更する事があります。

Please do not hesitate to contact our distributors or agents in your area for further information when necessary.

\* **The description covered in this instruction manual is subject to change for improvement of the commodity without notice.**

Copyright © 2012 JUKI CORPORATION

• 本書の内容を無断で転載、複写することを禁止します。

• All rights reserved throughout the world.

• 版权所有，严禁擅自转载、翻印本书的内容。

对本产品如有不明之处，请向代理店或本公司营业部门询问。

※ 本使用说明书中的规格因改良而发生变更，请订货时确认。