

JUKI®

INDUSTRIAL SEWING MACHINE

MODEL

PLK-G2516

TECHNICAL MANUAL

SEWING MACHINE HEAD

FOR SAFE USE

Before the installation, operation, and inspection for this product, read the “FOR SAFE USE” and the technical manuals carefully. Also read the other technical manuals, “Control Unit” and “Operation Panel” describing some instructions, which are not in this manual, and use the sewing machine properly.

SAFETY INDICATIONS

	DANGER	Indicates that incorrect handling may cause hazardous conditions, resulting in death or severe injury.
	CAUTION	Indicates that incorrect handling may cause hazardous conditions, resulting in medium or slight personal injury or physical damage. Note that CAUTION level may lead to a serious consequence according to the circumstances. Always follow the instructions of both levels because they are important to personal safety.

CAUTION INDICATIONS

No.	Caution indication	Description
1		<p><u>Precaution for sewing machine operation:</u></p> <p>Indicates that removing the safety and operating the sewing machine for some other purposes with power-on are prohibited.</p> <ul style="list-style-type: none"> ● Please do not operate the sewing machine without protective equipment such as a needle guard, an eye guard, a belt cover or the others. ● Please turn off the power switch when threading, changing a needle and a bobbin, cleaning, and lubricating.
2		<p><u>Caution for fingers injury:</u></p> <p>Indicates a possibility of fingers (hands) injury in a certain condition.</p>
3		<p><u>Caution for squeezing fingers:</u></p> <p>Indicates a possibility of squeezing fingers in a certain condition.</p>
4		<p><u>Indication of pulley rotation direction:</u></p> <p>Indicates a normal pulley rotation direction of sewing machine. (For sewing machine with pulley)</p>

SAFETY PRECAUTIONS



To prevent from receiving an electric shock, always turn off a power switch and unplug power supply when opening a control box, and then open after ten minutes passes.



USAGE ENVIRONMENT

Please do not operate the sewing machine under the following conditions.

- (1) In the ambient temperature of 35 degrees (95°F) or more than 35 degrees, or the ambient temperature of 5 degrees or less than 5 degrees (41°F).
- (2) In the ambient temperature of 55 degrees (131°F) or more than 55 degrees, or the ambient temperature of -10 degrees or less than -10 degrees (18°F) during transportation.
- (3) In the relative humidity exceeding 85% or less than 45%.
- (4) In the open-air place or the location that receives direct sunlight.
- (5) In the place near heat sources such as heating devices.
- (6) In the atmosphere filled with dust, explosive gas, or corrosive gas.
- (7) In the place where the fluctuation in the power voltage of 10% or more than 10%, or the power voltage of -10% or less than -10% of the fixed power voltage.
- (8) In the place where the power source cannot supply enough voltage to keep the motor running.
- (9) In the place filled with strong electric noises such as high-frequency welders.

INSTALLATION

- (1) Please have some specialists, who have enough experience for the sewing machine installations, install the sewing machine.
- (2) Please have a qualified electrician perform necessary electric wiring.
- (3) Please do not operate until the sewing machine is repaired when any damage or fault is found on the sewing machine at the installation.
- (4) Please do not refurbish the sewing machine.
- (5) The sewing machine is heavy. For the safety, please make sure to install the sewing machine head by more than one person.
- (6) When tilting the sewing machine, please stand at the hinge side and hold the sewing machine with both hands. Also, please lock the caster on the steel stand
- (7) When tilting the sewing machine, the work clamp slides toward the hinges. Remember to move the work clamps Fully to the right side of the casting before placing the sewing head in the sewing position.
- (8) Please lock the caster on the steel stand to prevent the machine from moving before tilting the sewing machine.

- (9) Please make sure to fit the safety protective equipment (the motor cover or the others) and the accessory protective equipment (the eye guard) that removed temporarily for installation.
- (10) If the table and the steel stand are not original, the table and the steel stand have to be strong enough to withstand the weight and Vibration of the sewing machine.
- (11) When fitting the caster to the steel stand that are not original, the caster with locking function has to be strong enough to withstand the weight and Vibration of the sewing machine.

SEWING

- (1) Please make sure to turn the power switch off before installing or replacing needles.
- (2) Please pay attention for the fingers not to be injured by the needle point.
- (3) Please make sure to turn power switch off before lubricating.
- (4) Please pay attention that oil does not get on your skin or in your eyes as it may cause an inflammation.
- (5) Please make sure to keep oil out of the reach of children who may drink oil by mistake.
- (6) Please make sure to turn the power switch off before threading a needle.
- (7) Before starting the sewing, please make sure the position and the function of the halt switch.
- (8) Please do not touch the operating parts during sewing operation.
- (9) It is very dangerous to operate the sewing machine without safety guards (eye guards, belt covers, link covers, finger guards or the others).
Please make sure to operate the sewing machine with safety guards.
- (10) Please make sure to turn the power switch off when stopping the sewing machine temporarily.

ADJUSTMENT

- (1) Please make sure to turn the power switch off before adjusting the sewing machine.
- (2) If the adjustment is required while the power switch on, do not step on the foot switch by mistake.
- (3) Please be careful not to be injured by a sharp part such as the needle and the shuttle hook point.
- (4) Please make sure to put the safety guards (eye guards, belt guards, link covers, and finger guards or the others) back on the initial position after the sewing machine adjustment.
- (5) Please make sure to lock the caster on the table when tilting the sewing machine.

CONTENTS

1. STRUCTURE OF THE SEWING MACHINE	1
2. SPECIFICATION	2
3. INSTALLATION	3
3-1. Preparation of the table	3
3-2. Preparation of the steel stand	4
3-3. Installation of the control box	4
3-4. Installation of the operation panel	4
3-5. Installation of the power switch and foot switch	4
3-6. Installation of the oil pan	5
3-7. Installation of the machine head	5
3-8. Installation of the tilting detect switch	6
3-9. Installation of the eye guard	6
3-10. Installation of the gas spring	7
3-11. Connection of the electric cables	8
3-12. Installation of the thread stand	9
3-13. Connection of the air tube	9
3-14. Installation of the spindle motor	10
4. LUBRICATION	11
5. PROPER OPERATION	11
5-1. Initial setting of the control box	11
5-2. Installation of the needle	12
5-3. Threading the upper thread	12
5-4. Winding the bobbin thread	13
5-5. Setting the bobbin	14
5-6. Setting the bobbin case	14
6. SEWING	15
6-1. The sewing operation	15
6-2. Operation of the halt switch	16
6-3. Adjustment of the thread tension	16

7. STANDARD ADJUSTMENT	17
7-1. Adjustment of the needle bar position	17
7-2. Adjustment of the position between the needle and the shuttle hook	18
7-3. Adjustment of the clearance between the shuttle hook and the needle	19
7-4. Adjustment of the clearance between the driver and the needle	19
7-5. Adjustment of the shuttle race thread guide	20
7-6. Adjustment of the presser foot timing	21
7-7. Adjustment of the presser foot lift	22
7-8. Adjustment of the presser foot height position	23
7-9. Adjustment of the presser foot position	23
7-10. Adjustment of the presser foot walk during the sewing	24
7-11. Adjustment of the presser foot spring pressure	24
7-12. Adjustment of the wiper	25
7-13. Adjustment of the work holder pressure	25
7-14. Changing the work holder	26
7-15. Adjustment of the trimmer cam follower	27
7-16. Adjustment of the position of movable knife	27
7-17. Adjustment of the fixed knife position	28
7-18. Adjustment of the thread take up spring	28
7-19. Adjustment of the thread tail after the trimming	29
7-20. Adjustment of the upper thread tension release (the width between thread tension discs)	29
7-21. Adjustment of opening time of the upper thread tension release disks	29
7-22. Adjustment of the X-Y mechanical home position	30
7-22-1. Adjustment of the X direction	30
7-22-2. Adjustment of the Y direction	31
7-23. The X-Y drive timing belt tension	31
8. MAINTENANCE	32
8-1. Cleaning	32
8-2. Disposing of oil waste	32
9. TROUBLESHOOTING	33

APPENDIX

1. STRUCTURE OF THE SEWING MACHINE

PLK-G2516 industrial sewing machine consists of the following main parts.

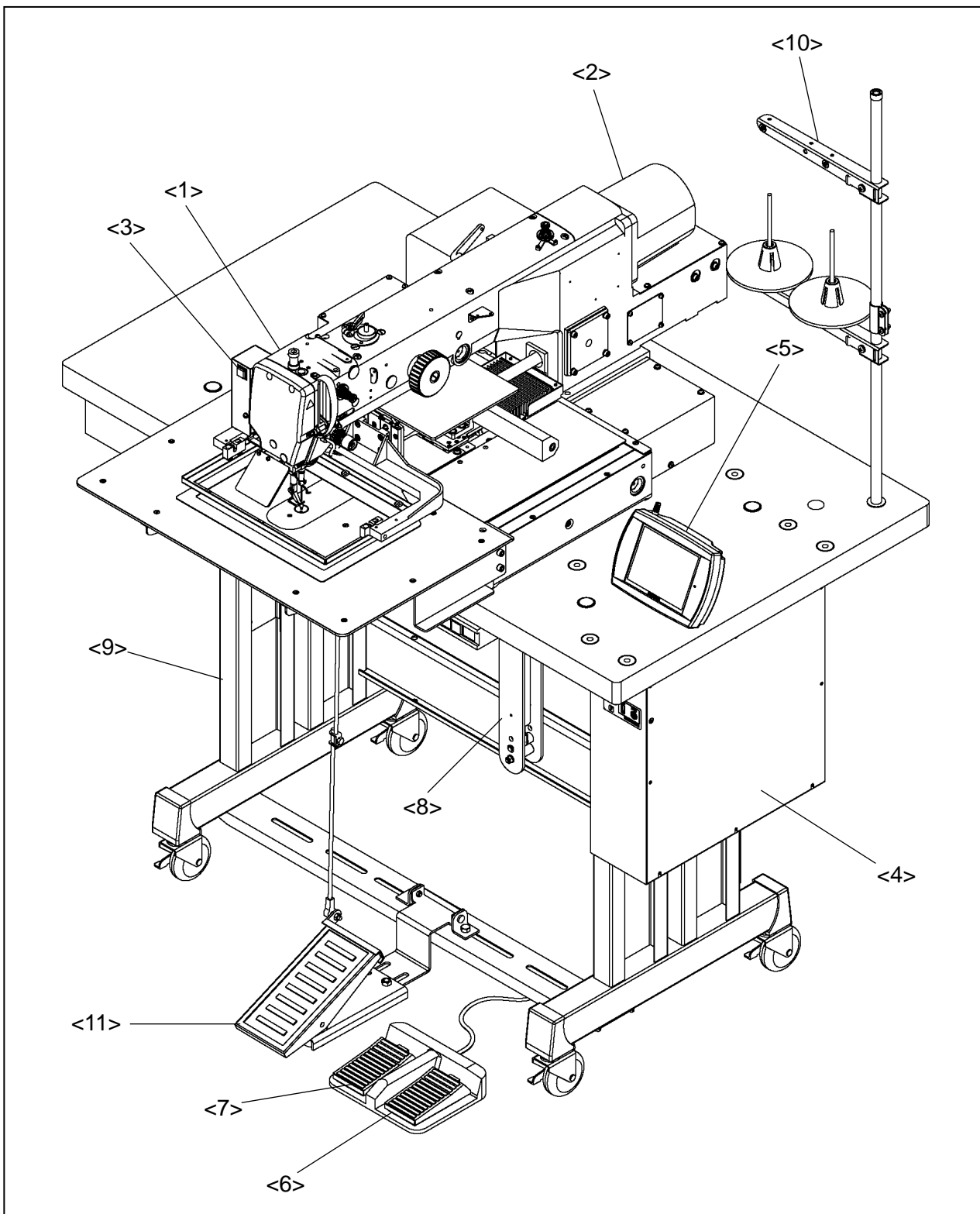

<1>: Sewing machine head <2>: Main shaft motor <3>: Halt switch <4>: Control box
<5>: Operation panel <6>: Work holder foot switch <7>: Start foot switch <8>: Gas spring
<9>: Steel stand <10>: Thread stand <11>: Work holder pedal (Option)

2. SPECIFICATIONS

Sewing area	: X-direction (left/right) 250 mm, Y-direction (front / back) 160 mm
Maximum sewing speed	: 2,800 rpm *1
Setting speed	: 10 speed levels in 200 rpm to 2,800 rpm
Stitch length	: 0.1 to 20.0 mm
Stitch type	: Single needle lock stitch
Maximum number of needles	: 20,000 per pattern
Storable sewing data item	: 900 patterns (internal memory)
Data memory	: Internal memory, USB memory
Needle bar stroke	: 41.2 mm
Thread take up lever stroke	: 68 mm
Class of needle	: DPX17#18 (at standard installation)
Wiper system	: Back to front wiping system
Presser foot lift *2	: 15 mm (12 mm as factory default setting)
Presser foot stroke *3	: In 4 mm to 10 mm (4 mm as factory default setting)
Work holder lift	: 30 mm
Hook	: Large size shuttle hook
Bobbin case	: With non racing spring
Bobbin	: Aluminum bobbin
Thread trimmer system	: Horizontal engagement with fixed knife and movable knife
Lubrication system	: Replenishment with the oil braids from the oil tanks
Lubrication oil	: Pulley SF oil
X-Y drive system	: Stepping motor feedback control Timing belt drive system
Machine dimensions	: 1,200 mm (W) ×1,068 mm (L) ×1,230 mm (H)
Weight	: Total 161.5 Kg
Type of motor	: XL-K756-20
Type of controller	: PLK-G-CU-20
Type of operation panel	: PLK-G-PAL
Power	: In 200V to 240V single-phrase or three-phrase The power in 110V to 120V or in 380V to 415V is compatible with power unit (option).

*1 : Sewing speed may be limited by the operation or sewing condition.

When sewing at speeds of over 2,500rpm, use an anti-noise protective equipment as needed.

*2 : Presser foot lift is the height of the presser foot after the sewing has stopped.

*3 : Presser foot stroke is the up and down movement of the presser foot while sewing.

3. INSTALLATION



- (1) Please have some specialists, who have enough experience for the sewing machine installations, install the sewing machine.
- (2) Please have a Qualified Electrician perform necessary electric wiring.
- (3) Please do not operate until the sewing machine is repaired when any damage or fault is found on the sewing machine at the installation.
- (4) Please do not refurbish the sewing machine.
- (5) If the table and the steel stand are not original, the table and the steel stand have to be strong enough to withstand the weight and Vibration of the sewing machine.
- (6) When fitting the caster to the steel stand that are not original, the caster with locking function has to be strong enough to withstand the weight and Vibration of the sewing machine.

3-1. Preparation of the table

- (1) If the table is not original, the thickness of the table is required to have 40mm and that is strong enough to withstand the weight and Vibration of the sewing machine.
- (2) Manufacture the table as shown on the figure below.

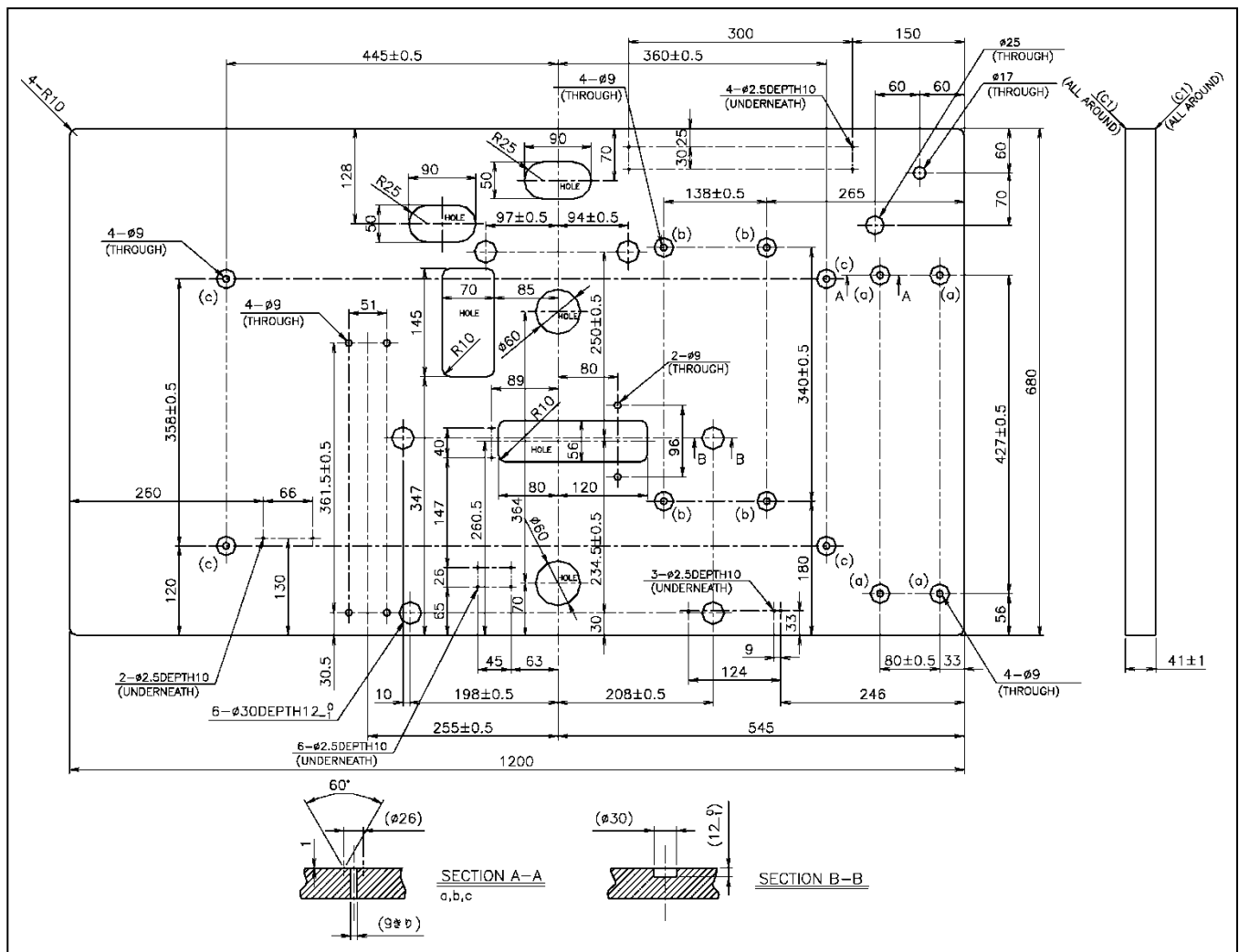

3-2. Preparation of the steel stand

- (1) If the steel stand is not original, please refer to the dimensions shown on the figure at the right.
- (2) When fitting the caster to the steel stand, the steel stand has to be strong enough to withstand the weight and Vibration of the sewing machine.
- (3) If the steel stand is PLK-G1010 original, assemble the steel stand with the assembling instructions enclosed in the packing.

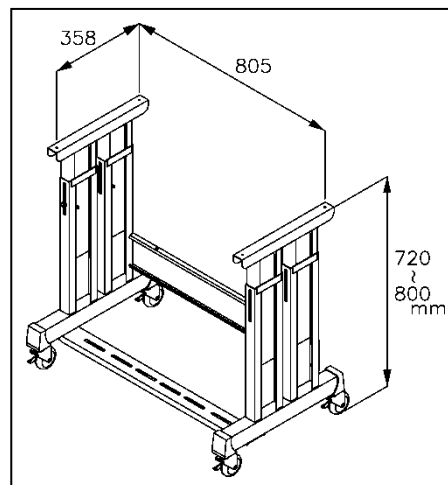

3-3. Installation of the control box

Install the control box with the instructions in the paragraph “[3] Installation” in the **CONTROL UNIT** technical manual.

* For connector location see page 7, Section 3-10 of this catalog.

3-4. Installation of the operation panel

Connect the operation panel PLK-G-PAL with the CON A on the rear of the control box.

* See page 7 for the location.

3-5. Installation of the power switch and foot switch

- (1) Mount the power switch (No.1) with the wood screw (No.2) at the position as shown on the figure.
- (2) Hook up the connector (No.3) of the power switch to the control box CON B.
- (3) Attach the power plug (No.5) to the incoming electrical cable (No.4).
- (4) Fix the electric cables with the staples (No.6) to prevent the cables from hanging down.
- (5) Hook up the connector (No.8) of the foot switch (No.7) to the control box CON H.
- (6) As for the control box connector, refer to the instructions in the paragraph “3-10.Connection of the electric cables” in this manual.

[Notice] Power plug (No.5) is not included in accessory box.

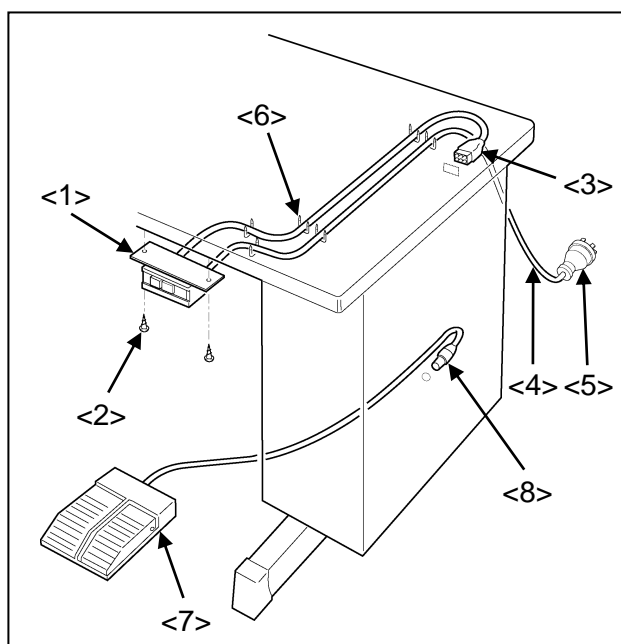

- <1>: Power switch
- <2>: Wood screw
- <3>: Power switch connector
- <4>: Electrical cable
- <5>: Power plug
- <6>: Staple (six staples)
- <7>: Foot switch
- <8>: Foot switch connector

3-6. Installation of the oil pan

- (1) Remove the oil pan A and B (No.1, No.2) from the accessory box then, set the oil bottle (No.3) to the oil pan A and B (No.1, No.2).
- (2) Put the oil pan at the position shown on the figure then, fix the oil pan with staples (No.4).
- (3) Set the damper cushions (No.5) to the table.

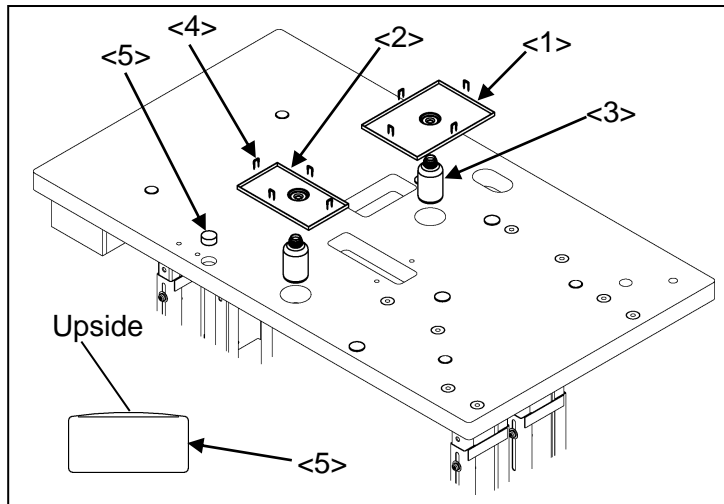

- <1>: Oil pan A (large)
- <2>: Oil pan B (small)
- <3>: Oil bottle (two bottles)
- <4>: Staple (eight staples)
- <5>: Damper cushion
(six cushions)

3-7. Installation of the machine head



CAUTION

- (1) The sewing machine is heavy. For the safety, please make sure to install the sewing machine head by more than one person.
- (2) When tilting the sewing machine, please stand at the hinge side and hold the sewing machine with both hands. Also, please lock the caster on the steel stand.
- (3) When tilting the sewing machine, the work clamp slides toward the hinges. Remember to move the work clamps Fully to the right side of the casting before placing the sewing head in the sewing position.

- (1) Put the machine head carefully on the damper cushion.
- (2) Insert the hinge shafts (No.1) into the hole on the machine then, fix it to the machine with set screws (No.2).
- (3) Fit the hinge rubbers (No.4) and the support plates (No.5) into the holes of the hinges (No.3) then, set the hinges to the hinge shafts.
- (4) Fit the screw holes of the hinges (No.3) to the bolt setting holes then, fix the machine with the socket bolts (No.6) and the flat washers (No.7).
- (5) Fix the head rest (No.8) with safety socket bolts (No.9).

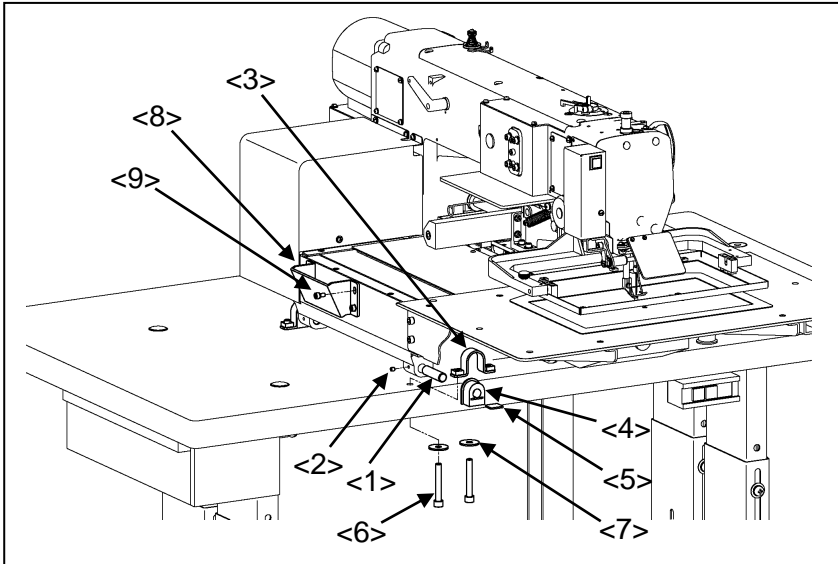

- <1>: Hinge shaft (two shafts)
- <2>: Set screw (two screws)
- <3>: Hinge (two hinges)
- <4>: Hinge rubber (two rubbers)
- <5>: Support plate (two plates)
- <6>: Socket bolt (four bolts)
- <7>: Flat washer (four washers)
- <8>: Head rest
- <9>: Safety socket bolt (four bolts)

3-8. Installation of the tilting detect switch

(1) Install the switch units (No.1) with the SW-MW screws (No.2) so that the switch turns on when the machine head in initial position is pushed by the machine table.

[NOTE] The switch unit (No.1) is temporarily fixed at the back side of the sewing machine bed. Fix it to the proper place as shown on the right figure.

[Notice] if the switch is not turned on, error [M-038] will occur.

- <1>: Switch units
- <2>: SW-MW screw (two screws)

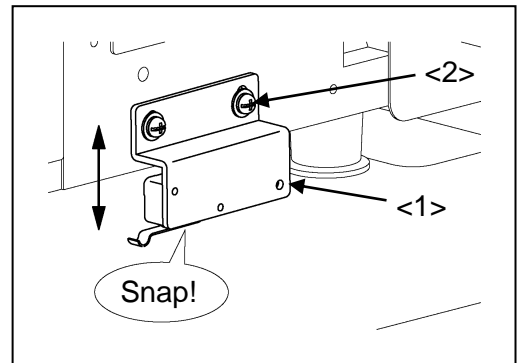

3-9. Installation of the eye guard

(1) Loosen the SW-MW screws (No.2) on the eye guard unit (No.1) then, mount the SW-PW screws (No.3) to the flat place of the sewing machine with the open guard.

(2) Return the open guard to the initial position then, tighten the SW-MW screws (No.2).

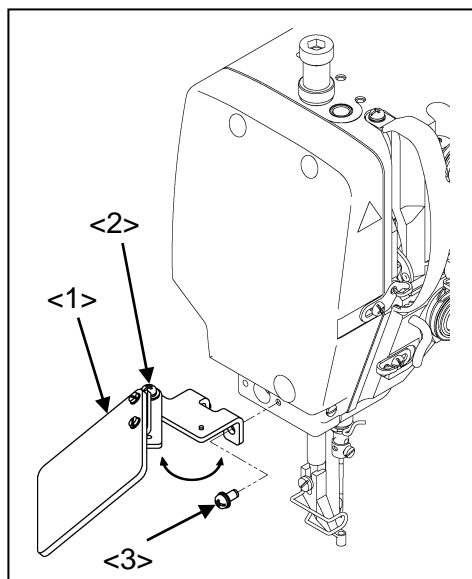

- <1>: Eye guard unit
- <2>: SW-MW screw
- <3>: SW-PW screw (two screws)

3-10. Installation of gas spring



- (1) The sewing machine is heavy. For the safety, please make sure to install the sewing machine head by more than one person.
- (2) When tilting the sewing machine, please stand at the hinge side and hold the sewing machine with both hands. Also, please lock the caster on the steel stand.
- (3) When tilting the sewing machine, the work clamp slides toward the hinges. Remember to move the work clamps fully to the right side of the casting before placing the sewing head in the sewing position.

- (1) Set up the gas spring unit (No.1) on the sewing table, and temporarily fix it with the socket bolts (No.2), the flat washers (No.3&4), and the nuts (No.5) so that it can be still movable.
- (2) Fit the holes of the gas spring head side to the bracket (No.6) hole then, insert the shaft (No.7).
- (3) Attach the snap pin (No.8) and the flat washer (No.9).
- (4) Adjust the position of the gas spring unit (No.1) with the machine head returned to the initial position. Fix the gas spring unit not to be inclined when the machine head is in initial position.

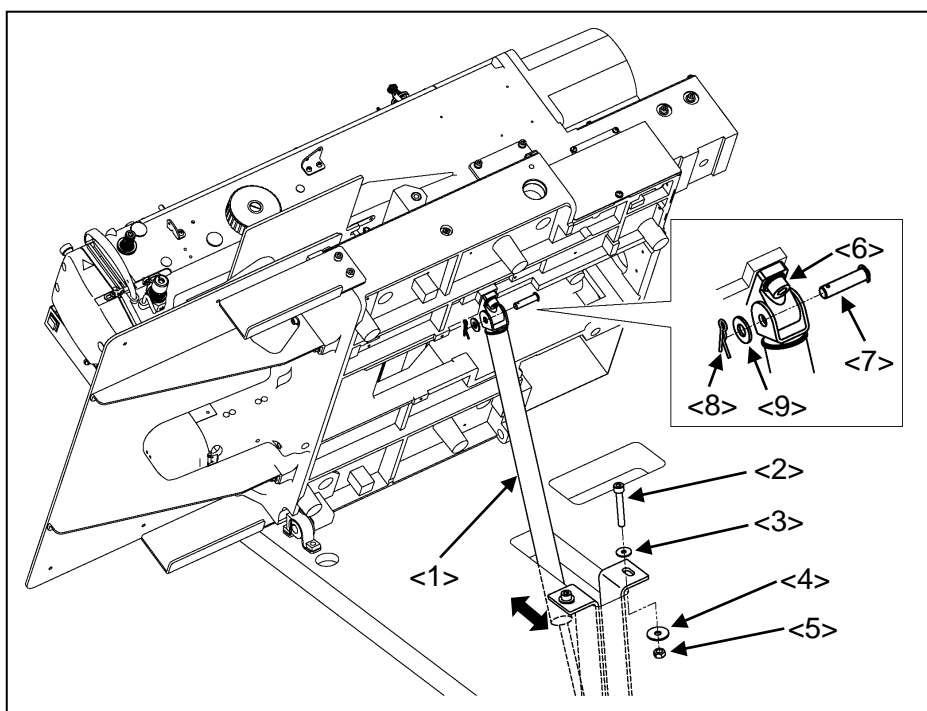

- <1>: Gas spring unit
- <2>: Socket bolt (two bolts)
- <3>: Flat washer (two washers)
- <4>: Flat washer (large) (two washers)
- <5>: Nut (two nuts)
- <6>: Bracket
- <7>: Shaft
- <8>: Snap pin
- <9>: Flat washer

- (5) Attach the cover (No.10) to the gas spring unit with the SW-PW screws (No.11).

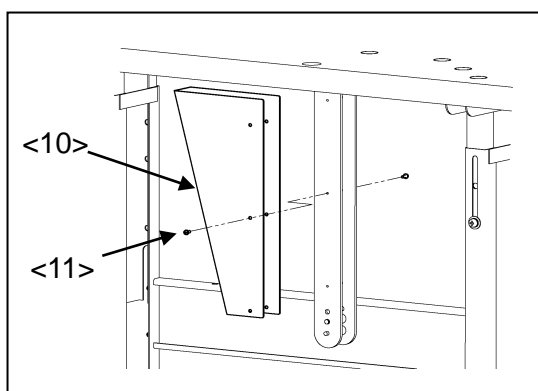

- <10>: Cover
- <11>: SW-PW screw (six screws)

3-11. Connection of the electric cables



(1) Please make sure to ground the place where there is a  mark. Failure to do so may cause electric shock and/or malfunction.

- (1) Connect the machine head and the control box with cables as shown on the figure.
- (2) Hold the dangling cables under the table with accessory tie holders (MB60A0420) and cord ties (MB60A0201). At this time, please check whether the cables are not pulled when tilting the sewing machine. There are wood screw prepared holes for the tie holders (MB60A0420) on the rear surface of the table.

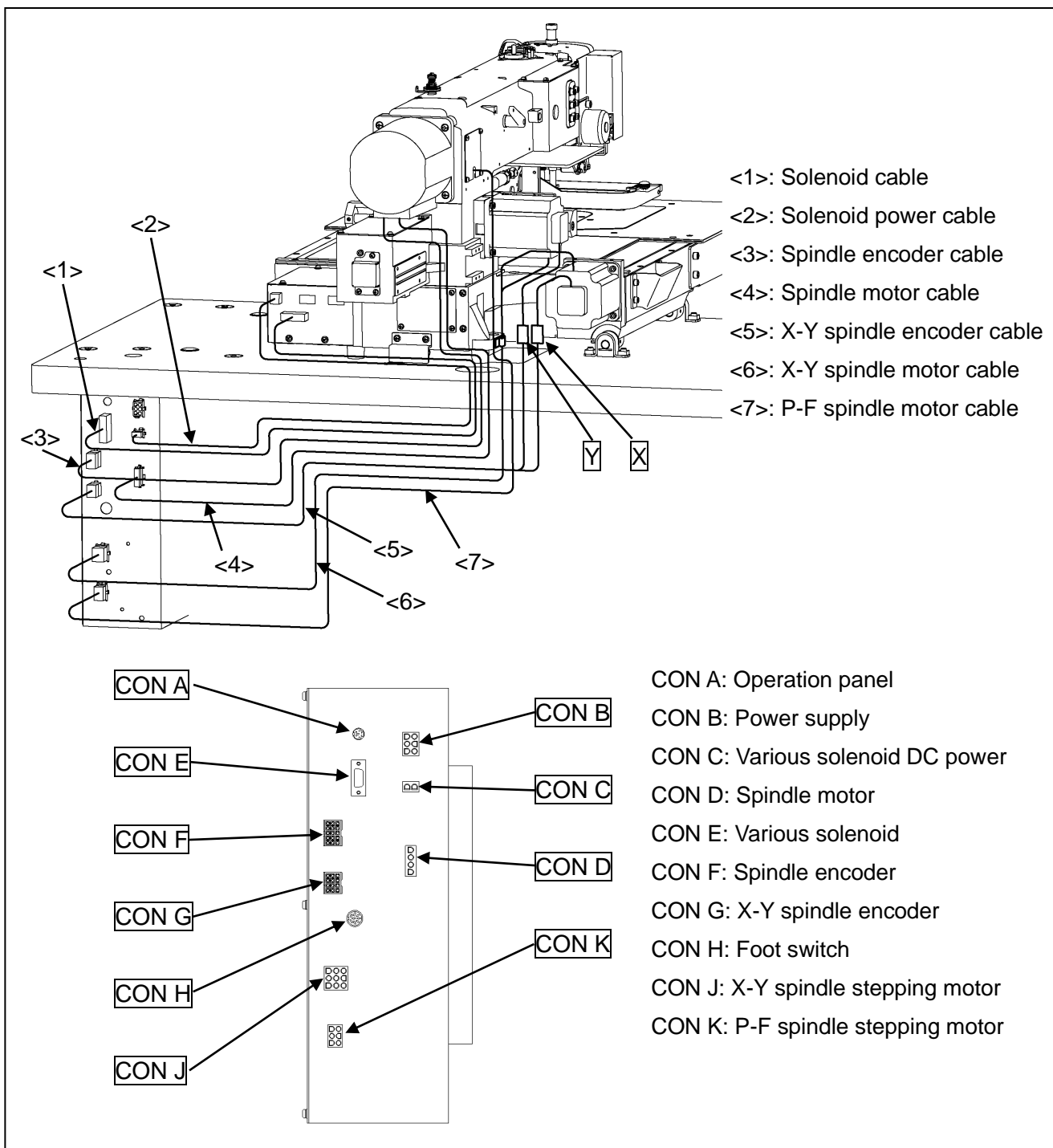

3-12. Installation of the thread stand

- (1) Assemble the parts (No.1 to No.11) of the thread stand as shown on the figure.
- (2) Fit the thread stand into the hole at the far right on the table stand with the nut (No.13) and the washers (No.12).

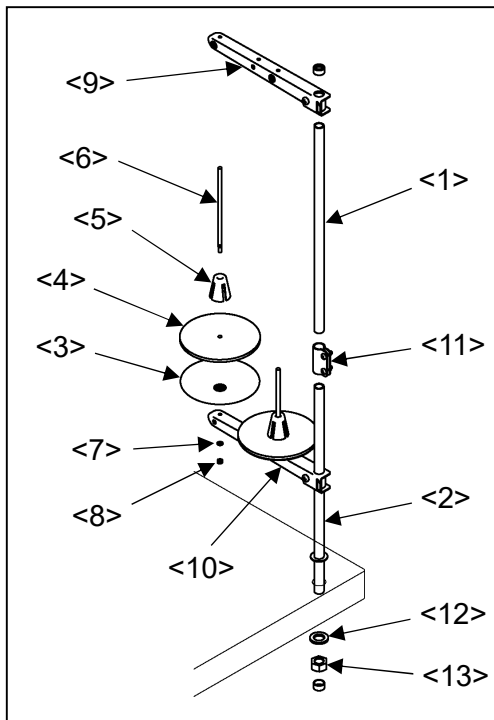

- <1>: Upper column pipe
- <2>: Lower column pipe
- <3>: Spool stand base (two stand bases)
- <4>: Spool mat (two mats)
- <5>: Spool holder (two holders)
- <6>: Spool shaft (two shafts)
- <7>: Spring washer (two washers)
- <8>: Nut (four nuts)
- <9>: Thread hunger
- <10>: Spool holder
- <11>: Column joint
- <12>: Washer
- <13>: Nut

3-13. Connection of the air tube

- (1) Remove the stepping motor cover.
- (2) Attach the air presser regulator assembly (No.1) underneath the table with the wood screws (No.2).
The prepared holes are provided for the wood screws on the rear surface of the table.
- (3) Cut the part of size $\phi 8$ air tube (No.3) enclosed in the accessory box into about 1 meter length then, insert one end of this air tube into the manifold air fitting (No.5). The manifold is jointed with the magnet valves (No.4) and located at the left side surface of the sewing machine head.
Beside, pass the other end of the air tube (No.3) through the cut out hole of the table top then, insert it into the air outlet fitting (No.6) of the cut out hole of the table top then, insert it into the air outlet fitting (No.6) of the air presser regulator (No.1).
- (4) Insert the one end of the resting air tube (No.3) into the intake air fitting (No.7) of the air coupling to be adopted with the air supply source provided in your factory.
One of the air couplings is enclosed in the accessory box.

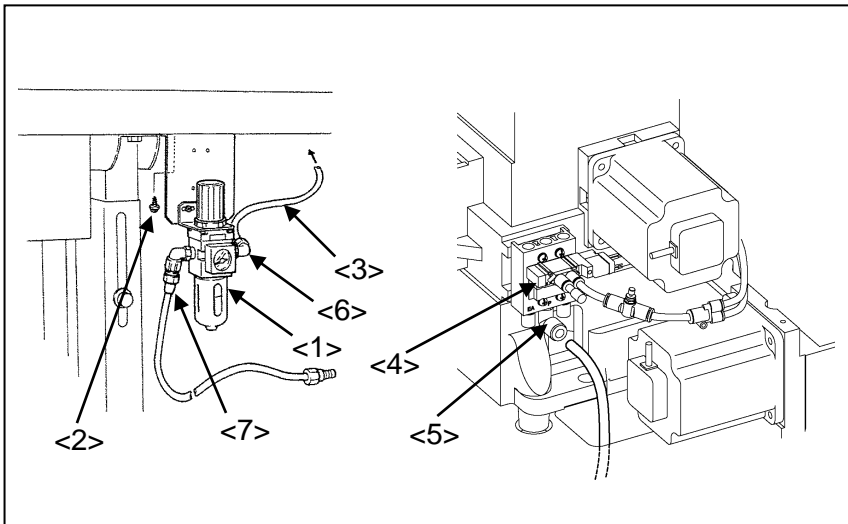

- <1>: Air presser regulator unit
- <2>: wood screw (two screws)
- <3>: Air tube (size ϕ 8)
- <4>: Manifold (with magnet valves)
- <5>: Manifold air fitting
- <6>: Air outlet fitting
- <7>: Intake air fitting

3-14. Installation of the spindle motor

- (1) If the spindle motor (No.1) has been removed from the machine for the adjustment or the like, fix the spindle motor as the procedure described below.
- (2) Set the pin (No.3) position of the bushing to the motor mark (No.2).
- (3) Adjust the clearance between the motor and the coupling (No.4). Use the part measuring 7mm on the gauge (No.5). Position Bolt "A" (No.6) in the UP position when reinstalling the coupling to the machine top shaft. Make sure the clearance of the coupling is from 2.0 to 3.2mm.
- (4) Turn the pulley (No.8) in the direction of the arrow then, slip the gauge (No.5) in between the needle bar and the needle plate. Use the part of S side (50.1mm) on the gauge.
- (5) Be careful not to make the motor turn and fit the coupling to the upper shaft, and then tighten the bolt A (No.6) first and the bolt B (No.7) second.

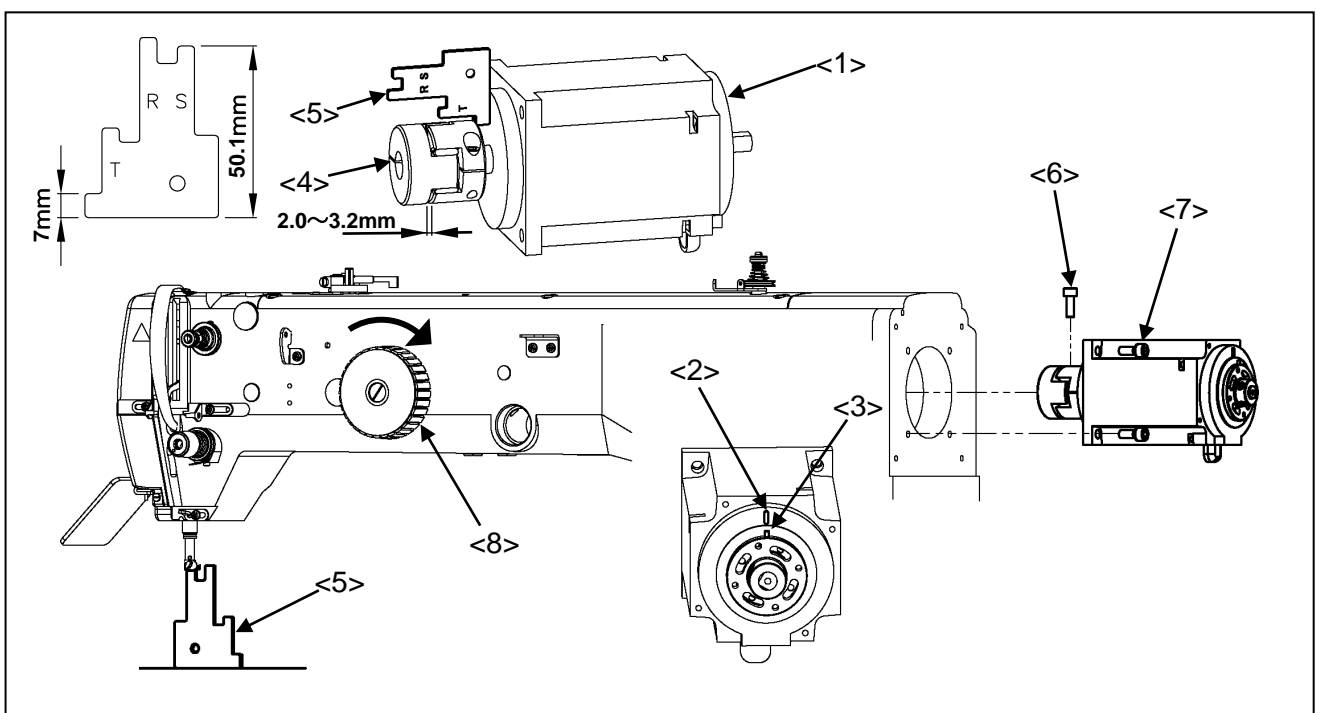

- <1>: Spindle motor
- <2>: Motor mark
- <3>: Pin
- <4>: Coupling
- <5>: Gauge
- <6>: Bolt A
- <7>: Bolt B

4. LUBRICATION



CAUTION

- (1) Please make sure to turn power switch off before lubricating.
- (2) Please pay attention that oil does not get on your skin or in your eyes as it may cause an inflammation.
- (3) Please make sure to keep oil out of the reach of children who may drink oil by mistake.

[Notice] Please make sure to lubricate when operating for the first time after the installation. Also, please make sure to check the amount of oil when the machine has not been used for a long time.

- (1) The oil tanks are set at three places of the machine. Pour oil through the oil holes of (No.1 to No.3) to the oil tanks.
- (2) The oil tanks have level marks (at the center of the tank). Running out the oil may cause the machine to make abnormal noise and seize up. When the amount of oil decreases to one-third or less than one-third, make sure to fill the tank with oil.

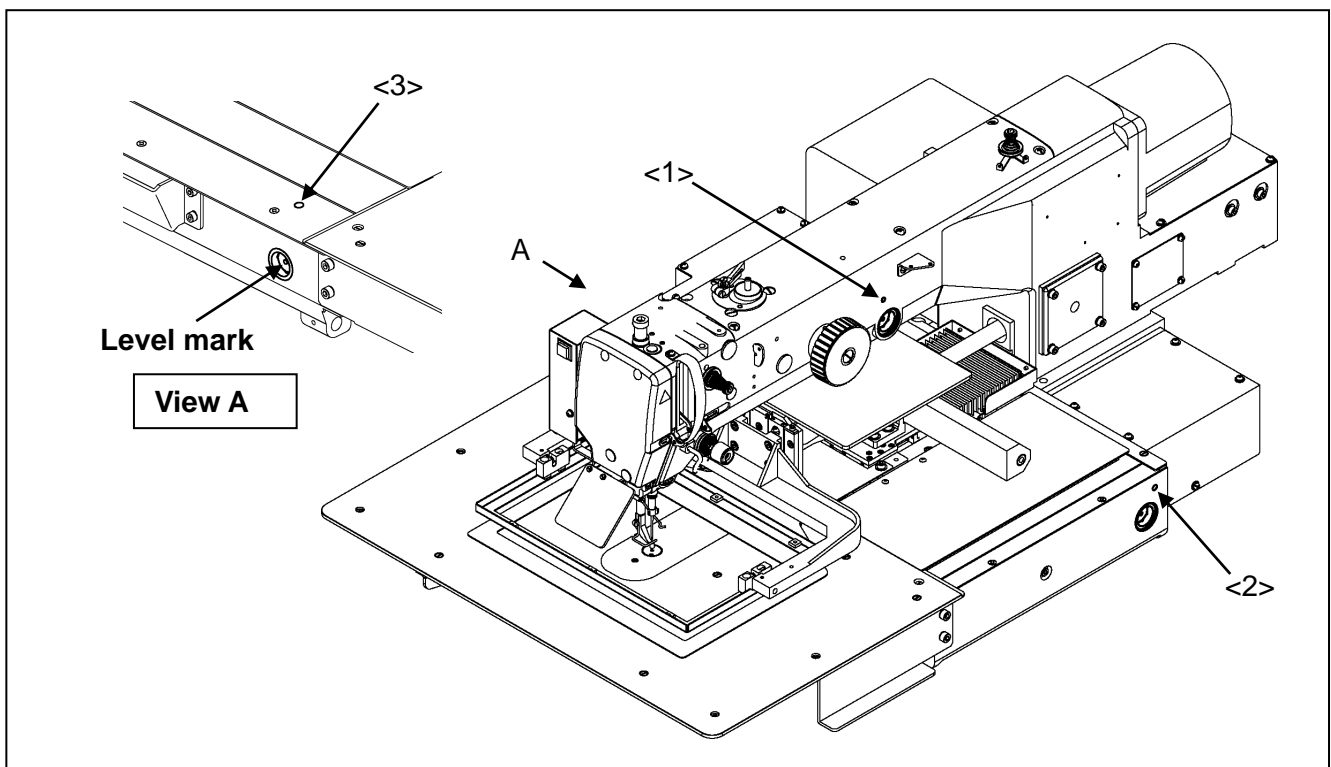

5. PROPER OPERATION

5-1. Initial setting of the control box

When using the sewing machine for the first time, the model and the language of the sewing machine in use have to be set.

Refer to the instructions in the paragraph "[6] Initial Setting of System (Model/language Setting)" in the **CONTROL UNIT** technical manual.

5-2. Installation of the needle



(1) Please make sure to turn the power switch off before installing or replacing needles.

(2) Please pay attention for the fingers not to be injured by the needle point.

(1) Loosen the set screw (No.1) then, insert a new needle (No.2) until the needle head is reached the end of the hole of the needle bar (No.3).

(2) Tighten the set screw (No.1) with facing the needle groove (No.4) to the front.

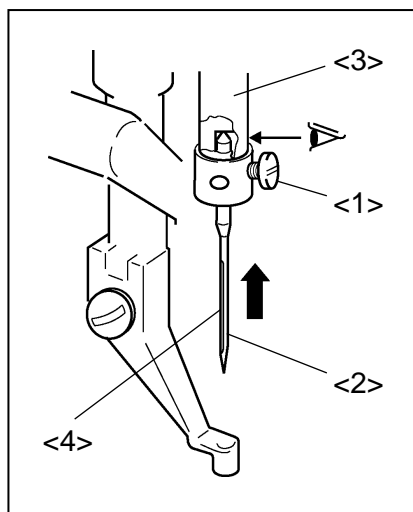

<1>: Set screw

<2>: Needle

<3>: Needle bar

<4>: Needle groove

5-3. Threading the upper thread



(1) Please turn the power switch off when threading a needle.

Thread the upper thread as shown on the figure.

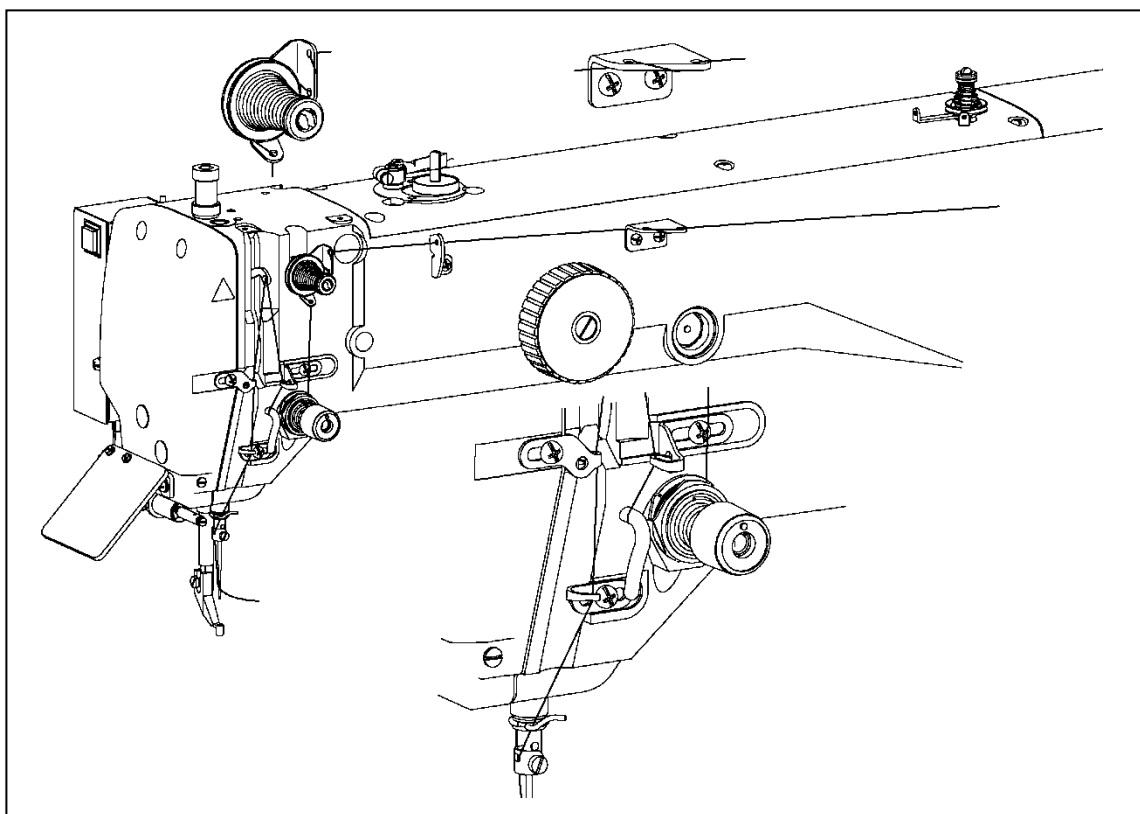

5-4. Winding the bobbin thread



CAUTION

(1) Please do not touch the rotating part during winding thread. Doing so may cause injury and/or the machine failure.

[Notice] Please make sure to pull the upper thread out of the needle before winding the bobbin thread.

- (1) Route the thread as shown in the below figure then, wind the thread to the bobbin (No.1) in the direction of “a” arrow several times. Then fit the bobbin to the bobbin winder (No.2) and push in the bobbin presser arm (No.3).
- (2) With the machine in the Bobbin Wind Mode, step on the work holder foot switch first and then the start switch second so that the thread continues winding to the bobbin while the start switch is stepped on.
- (3) When the bobbin finishes winding a certain amount (80 to 90 % of the outside diameter of bobbin) of thread, the bobbin presser arm is returned to the initial position. Adjust the amount of the winding thread with the subsidiary arm (No.4).
- (4) To wind the bobbin thread during the sewing operation, carry out the procedure (1) above then, the bobbin winding is performed automatically.

For the bobbin winding mode, refer to the instructions in the paragraph “[3] Explanations of basic screen, icons and operation “5. The Bobbin Winding screen” is explained below” in the

OPERATION PANEL technical manual.

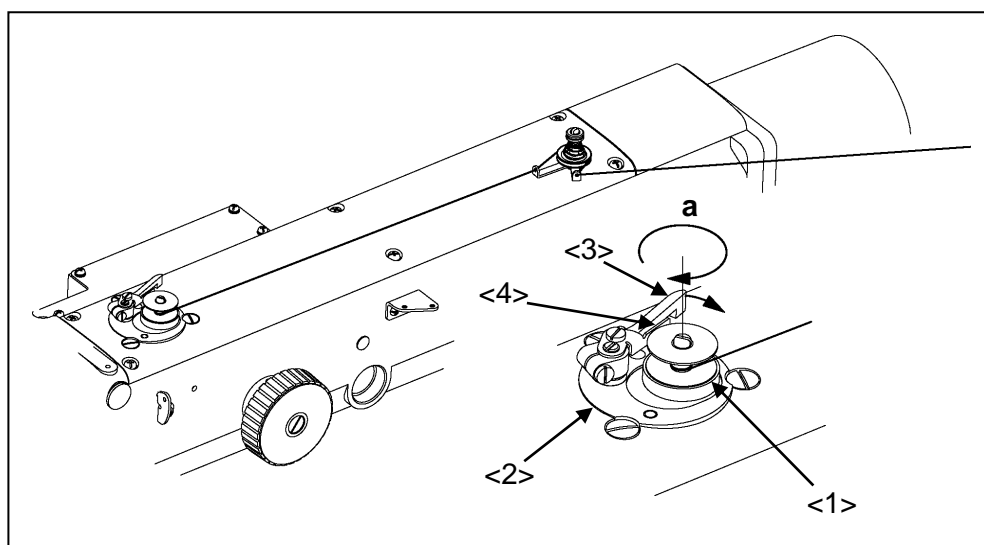

<1>: Bobbin <2>: Bobbin winder <3>: Bobbin presser arm <4>: Subsidiary arm

5-5. Setting the bobbin

- (1) Insert a full Bobbin (No.2) into the bobbin case (No.1).
- (2) Pull out the bobbin thread (No.3) from the slit (No.4) and pass the thread through the thread hole (No.5). When the bobbin thread is pulled, the pin rotates in the arrow direction shown on the figure. If the pin starts rotating to the opposite direction, turn the bobbin over and reset the bobbin.

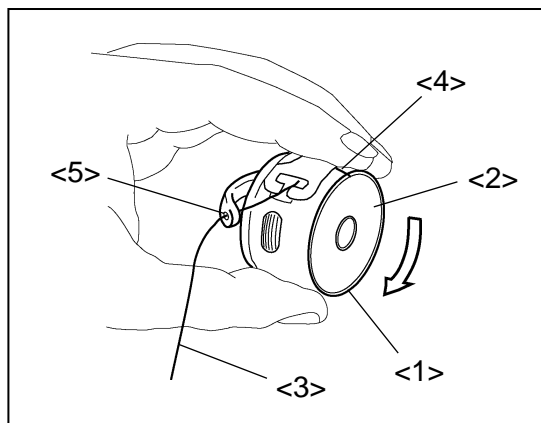

- <1>: Bobbin case
- <2>: Bobbin
- <3>: Thread
- <4>: Bobbin case slit
- <5>: Bobbin case thread hole

5-6. Setting the bobbin case

- (1) Pull the bobbin thread about 2.5cm out of the thread hole of the bobbin case.
- (2) Open the cylinder cover (No.1).
- (3) Open the bobbin case latch (No.2) and hold it then, fit it securely in the shuttle hook (No.3).

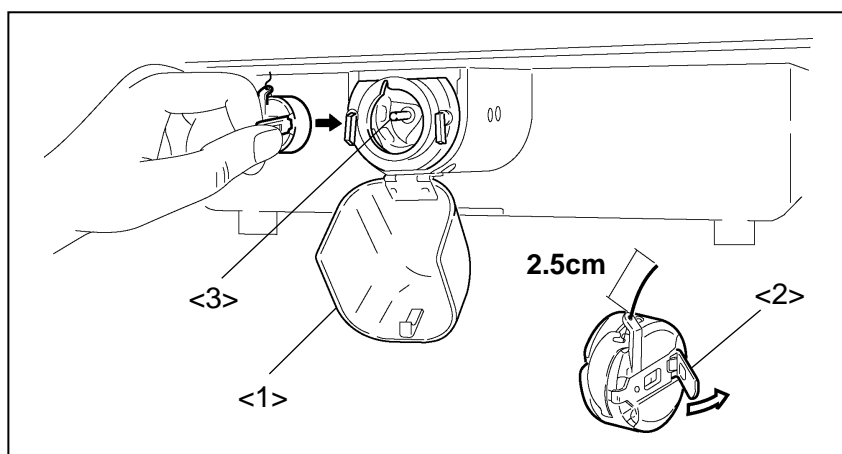

- <1>: Cylinder cover
- <2>: Bobbin case latch
- <3>: Shuttle hook

6. SEWING





- (1) Before starting the sewing, please make sure the position and the function of the halt switch.
- (2) Please do not touch the operating parts during sewing operation.
- (3) It is very dangerous to operate the sewing machine without safety guards (eye guards, belt covers, link covers, finger guards or the others). Please make sure to operate the sewing machine with safety guards.
- (4) Please make sure to turn the power switch off when stopping the sewing machine temporarily.

6-1. The sewing operation

(1) Turn the power switch on.

(2) Press the home position return icon .

(3) Select a sewing data.

Press the  on the standard screen then, press the .

(4) Select a target (internal memory/USB memory) to read the data from.

The screen as default setting is set to the reading from internal memory mode.

(The mode display at the left top on the screen is )

Press the , when switching the reading from the internal memory to the reading from USB memory mode.

(Pressing the  also can switch the target.)

Press the  to switch the page with full of data.

(5) Select a data then, set the data.

Press the target data number then, press the .

(6) Set the sewing speed.

Set the appropriate sewing speed by selecting  or . (10 selections of 0 to 9)

(7) Set the sewing material under the work holder.

(8) When the black foot switch is stepped on, the work holder goes down.

(When the sewing material has to be reset, step the black color foot switch again to make the work holder go up.)

(9) Step on the gray color start switch so that the sewing machine starts sewing,

(10) After the sewing finishes, the work holder is lifted automatically then, the sewing material is released.

6-2. Operation of the halt switch

- (1) If accidents such as a thread breakage, needle breakage and others happened during the sewing, press the halt switch immediately.
The sewing machine stops instantly.
- (2) To cancel the halt state, press the halt switch again.
- (3) When continuing sewing, step on the grey foot switch to restart at the halted position. (Press the jogging in forward/reverse direction icon so that the sewing start position will move.)
- (4) To cancel sewing, press the home position return icon .

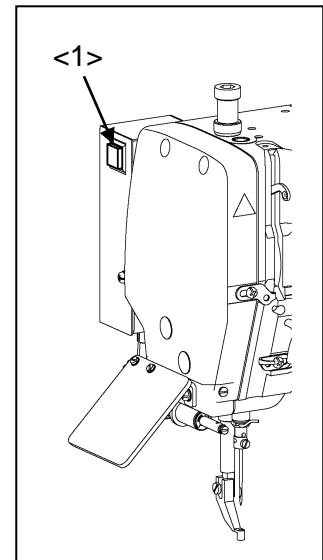

<1>: Halt switch

6-3. Adjustment of the thread tension

(1) Adjustment of bobbin thread tension

Adjust the bobbin thread tension with the thread tension adjusting screw (No.2) on the bobbin case (No.1). The thread tension becomes loose when loosening the thread tension adjusting screw (No.2) counterclockwise, and the thread tension becomes tight when tightening the thread tension adjusting screw clockwise.

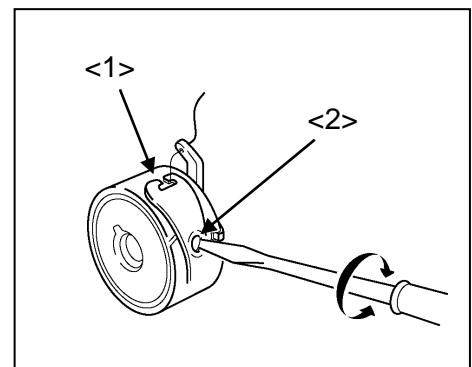

<1>: Bobbin case

<2>: Thread tension adjusting screw

(2) Adjustment of upper thread tension

Adjust the upper thread tension corresponding to the bobbin Thread tension. The upper thread tension becomes tight when tightening the thread tension adjusting nut (No.1) clockwise, and the upper thread tension becomes loose when loosening the thread tension adjusting nut counterclockwise.

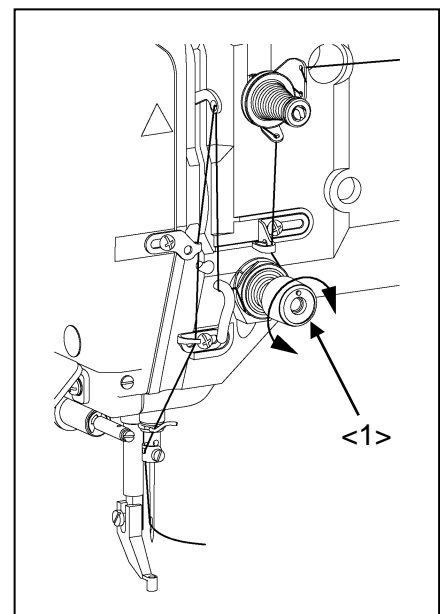

<1>: Thread tension adjusting nut

7. STANDARD ADJUSTMENT



CAUTION

- (1) Please make sure to turn the power switch off before adjusting the sewing machine.
- (2) When adjusting the sewing machine with the power switch on, please be careful not to step on the foot switch by mistake.
- (3) Please be careful not to be injured by a sharp part such as the needle and the shuttle hook point.
- (4) Please make sure to put the safety guards (eye guards, belt guards, link covers, and finger guards or the others) back on the initial position after the sewing machine adjustment.

7-1. Adjustment of the needle bar position

- (1) Turn the power switch off then, stop the needle bar (No.1) at the lowest position.
- (2) Move the needle bar to the position where the needle bar timing mark A is matched to the needle bar bushing (No.2) bottom line. (For the needle class DP×17)
- (3) If the position of the needle bar timing mark A is not matched to the needle bar bushing bottom line, remove the rubber plug (No.3) from the face cover then, loosen the needle bar holder set screw (No.4).
- (4) For the needle class DP×5, move the needle bar to the position where the needle bar timing mark B is matched to the needle bar bushing bottom line.

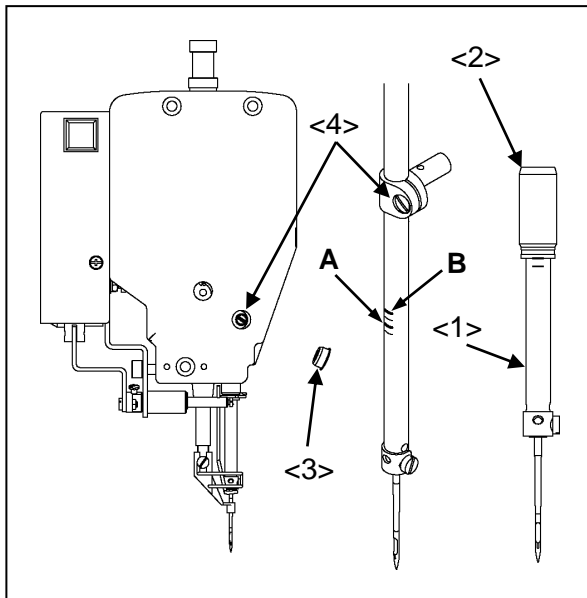

<1>: Needle bar

<2>: Needle bar bushing

<3>: Rubber plug

<4>: Needle bar holder set screw

Timing mark A: For the needle class DP×17

Timing mark B: For the needle class DP×5

7-2. Adjustment of the position between the needle and the shuttle hook

- (1) Turn the power switch off. Move up the needle bar (No.1) from the lowest position then, stop the needle bar at the position where the needle bar timing mark C is matched to the needle bar bushing (No.2) bottom line. (For the needle class DP×17)
- (2) Open the cylinder cover (No.3).
- (3) Remove the bobbin case (No.4).
- (4) Turn the hook retainer arm (No.5) then, remove the hook retainer (No.6).
- (5) Adjust the shuttle hook (No.7) point to match with the center line of the needle (No.8). The matched position is standard.
- (6) If the shuttle hook point is not matched with the center line of the needle, loosen the driver (No.9) set screw (No.10) then, turn the shuttle hook and the driver for the adjustment.
- (7) For the needle class DP×5, move the needle bar to the position where the needle bar timing mark D is matched to the needle bar bushing bottom line then, carry out the same procedure as described above.

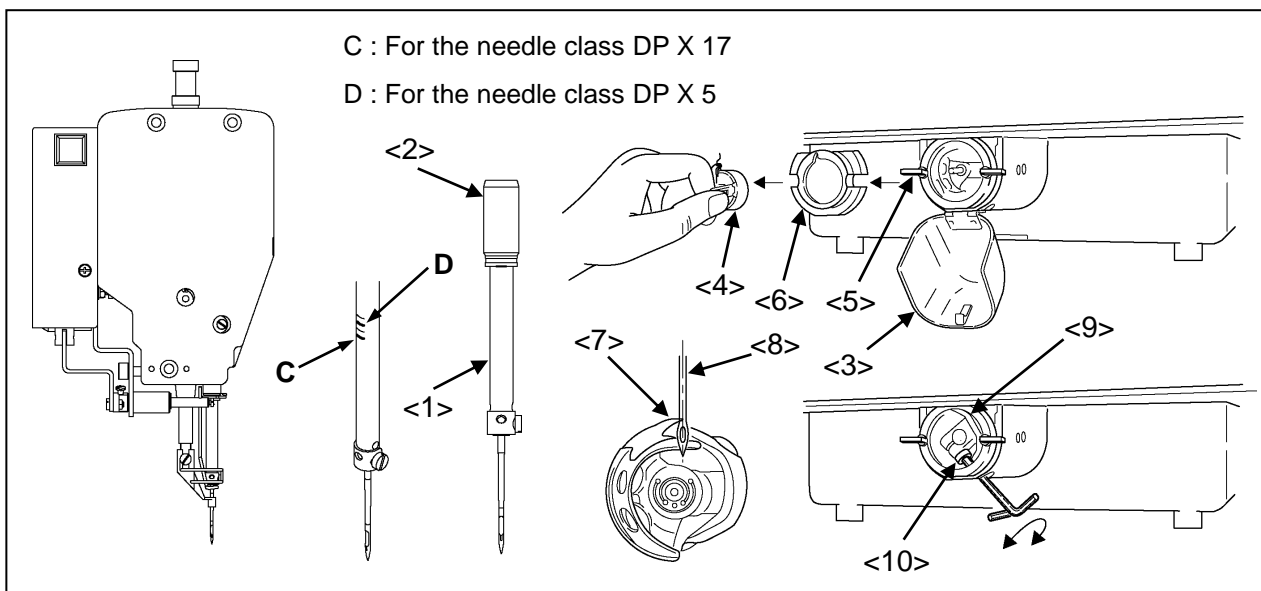

<1>: Needle bar <2>: Needle bar bushing <3>: Cylinder cover <4>: Bobbin case <5>: Shuttle hook retainer arm <6>: Hook retainer <7>: Shuttle hook <8>: Needle <9>: Driver <10>: Set screw

7-3. Adjustment of the clearance between the shuttle hook and the needle

- (1) Take the same procedure described in (1) to (4) of above paragraph 7-2.
- (2) Set the clearance between the shuttle hook (No.1) point and the needle (No.2) in 0 to 0.05 mm, standard position.
- (3) Loosen the shuttle race set screw (No.3) and turn the eccentric pin (No.4) to move the hook entirely back and forth for adjustment. Adjust the clearance to be standard, and tighten set screw (No.3). (*1)
- (4) After adjusting, check that the pulley can be turned lightly by hand.

*1: Be careful not to tighten the shuttle race set screw (No.3) excessively because a load is applied to the rotating shaft and it causes trouble.

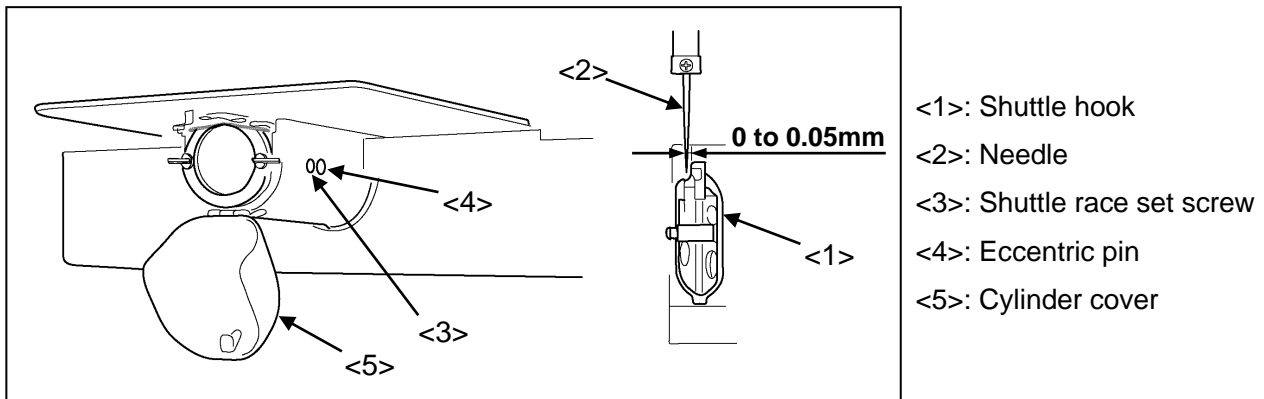

7-4. Adjustment of the clearance between the driver and the needle

- (1) Take the same procedure as above paragraph 7-3. from (1) to (4).
- (2) Check the clearance between the shuttle hook point and the needle has been adjusted in 0 to 0.05mm.
- (3) Loosen the lower shaft bushing screw (No.1) and turn the eccentric pin (No.2) so that the driver (No.3) moves back and forth. Adjust the clearance between the needle (No.4) and the driver (No.3) in 0 to 0.05mm, and tighten set screw (No.1). (*1)
- (4) After adjusting, check that the pulley can be turned lightly by hand.

*1: Be careful not to tighten the lower shaft bushing screw (No.1) excessively because a load is applied to the rotating shaft and it causes trouble.

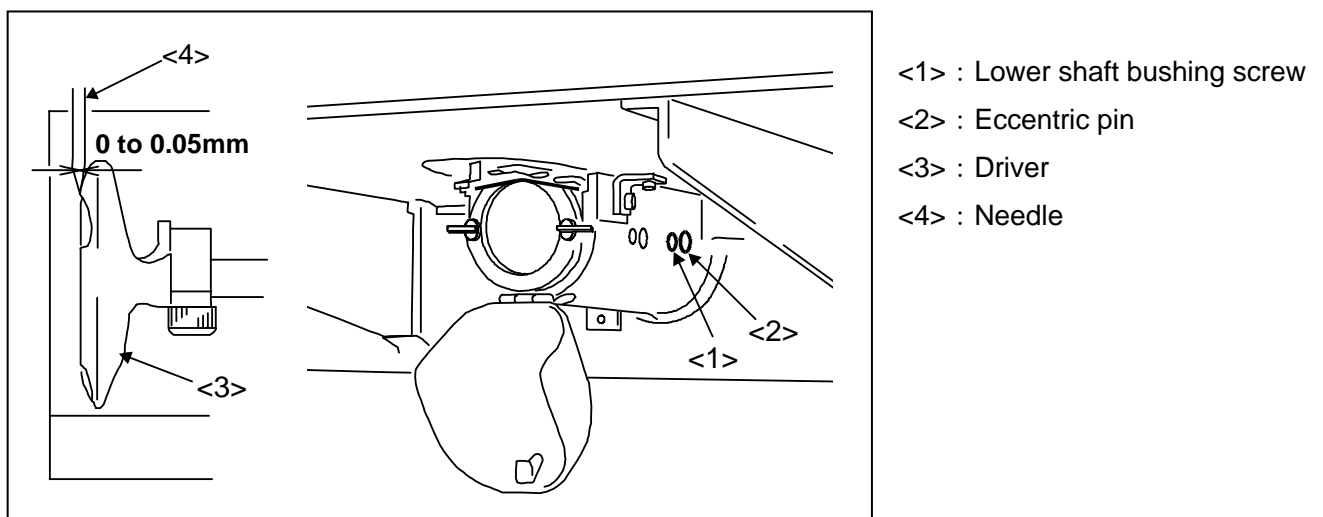

7-5. Adjustment of the shuttle race thread guide

- (1) Remove the ring-E type (No.3) which is engaging the movable knife (No.2) and the trimmer link (No.1).
- (2) Loosen the set screw (No.4) and remove the sliding plate (No.5) so that the shuttle race thread guide (No.6) shown on the figure appears.
- (3) Loosen the set screws (No.10) to match the hole in the shuttle race thread guide (No.6) with the needle bar center line so that the shoulder (No.9) of the shuttle race thread guide matches with the rear side line (No.8) of the needle. At this time, make sure that there is a clearance between the hook retainer and the shuttle race thread guide (No.6) at least the thread can be passed through. (The standard clearance is 0.8mm.) The wide clearance causes the trimming failure.
- (4) After the adjustment, assemble the place with the reverse procedure. Make sure to set the sliding plate (No.5) at this time so that the needle (No.11) comes down to the center of the needle hole (No.12) of the needle plate.

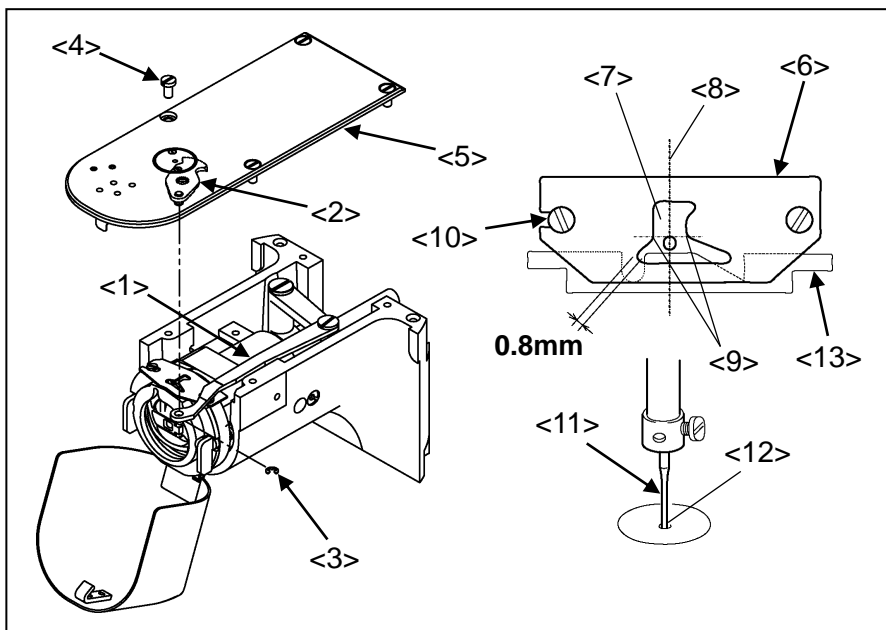

- <1>: Trimmer link
- <2>: Movable knife
- <3>: Ring-E type
- <4>: Set screw
- <5>: Sliding plate
- <6>: Shuttle race thread guide
- <7>: Hole of shuttle race thread guide
- <8>: Needle bar center line
- <9>: Shoulder
- <10>: Set screw
- <11>: Needle
- <12>: Needle hole
- <13>: Shuttle hook retainer

7-6. Adjustment of the presser foot timing

With changing the timing to sewing materials, the skip stitches can be prevented or the seam tightness can be improved. For example, the delay of the presser foot timing against the needle movement prevents the skip stitches especially to thin materials, and the advance of the presser foot timing can improve the seam tightness especially to thick materials.

The needle bar and the presser foot are set to move the lowest position together as the factory default.

- (1) Remove the cover (No.1) and loosen the set screw A (No.3) and B (No.4) of the eccentric cam (No.2).
- (2) Keep the thread take-up lever at the highest position then, adjust the eccentric cam angle so that set screw B (No.4) is positioned half size upper from the center line of the upper shaft (shown on the lower right figure). Retighten the set screws (No.3 & No.4).
- (3) Turn the pulley by hand to check the timing then, put the cover (No.1) back on the original location.

*To speed up the presser foot timing, turn the eccentric ring to the direction "a".

*To speed down the presser foot timing, turn the eccentric ring to the direction "b".

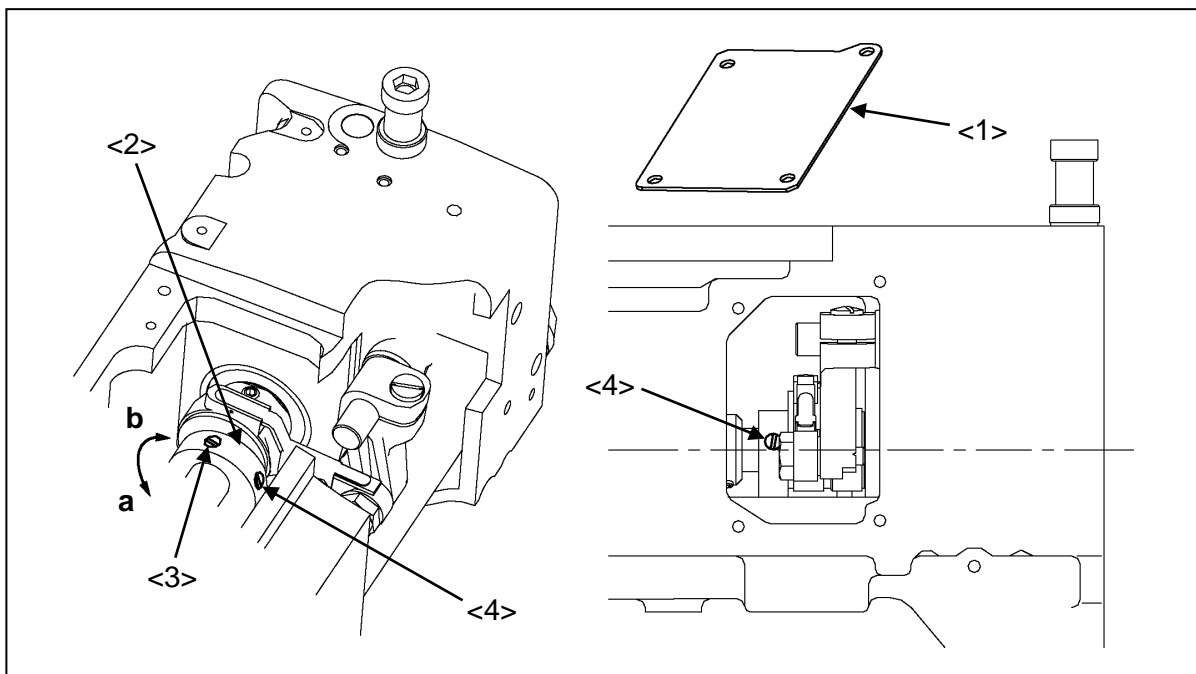

<1>: Cover <2>: Eccentric cam <3>: Set screw A <4>: Set screw B



7-7. Adjustment of the presser foot lift

The presser foot lift can be returned factory default setting at 15mm as the procedure shown below. Also, if the presser foot does not move after changing the presser foot correction value and the stroke, carry out the procedure below.

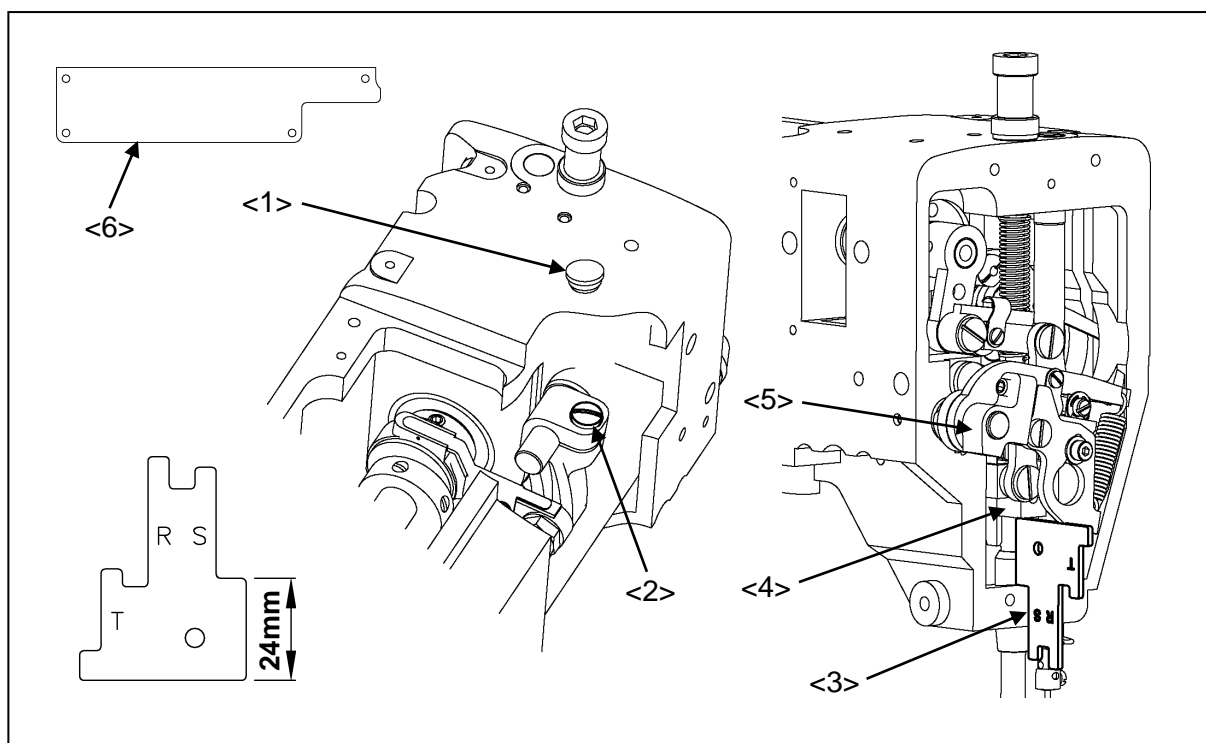
- (1) Remove the face cover, the rubber plug (No.1), and the PF motor cover (No.6).
- (2) Keep the thread take-up lever at the highest position then, loosen the arm set screw (No.2).
- (3) Slide the 24mm part on the gauge (No.3) in between the presser bar holder (No.4) and the arm.
- (4) Push down the presser foot lifting lever (No.5) then, tighten the arm set screw (No.2).



<1>: Rubber plug <2>: Arm set screw <3>: Gauge <4>: Presser bar holder
 <5>: Presser foot lifting lever <6>: PF motor cover

- (5) Turn the power switch on then, press the home position return icon .
 - (6) Check the clearance between the presser bar holder (No.4) and the arm with the 41mm part on the gauge (No.3). Refer to the next figure.
 - (7) If the clearance is less than 41mm, loosen the detector plate set screw (No.7) on the presser foot drive motor (No.6) and adjust the notch part of detector plate (No.8).
 *If it is more than 41mm, turn the detector plate to the direction "a".
 *If it is less than 41mm, turn the detector plate to the direction "b".
 - (8) Remove the gauge then, press the home position return icon  and make sure the clearance is 41mm.
- [Notice] If it is not 41mm, carry out the same procedure (7) and (8) again.
- (9) Put the face cover, the rubber plug (No.1), and the PF motor cover (No.6) back on the original location.

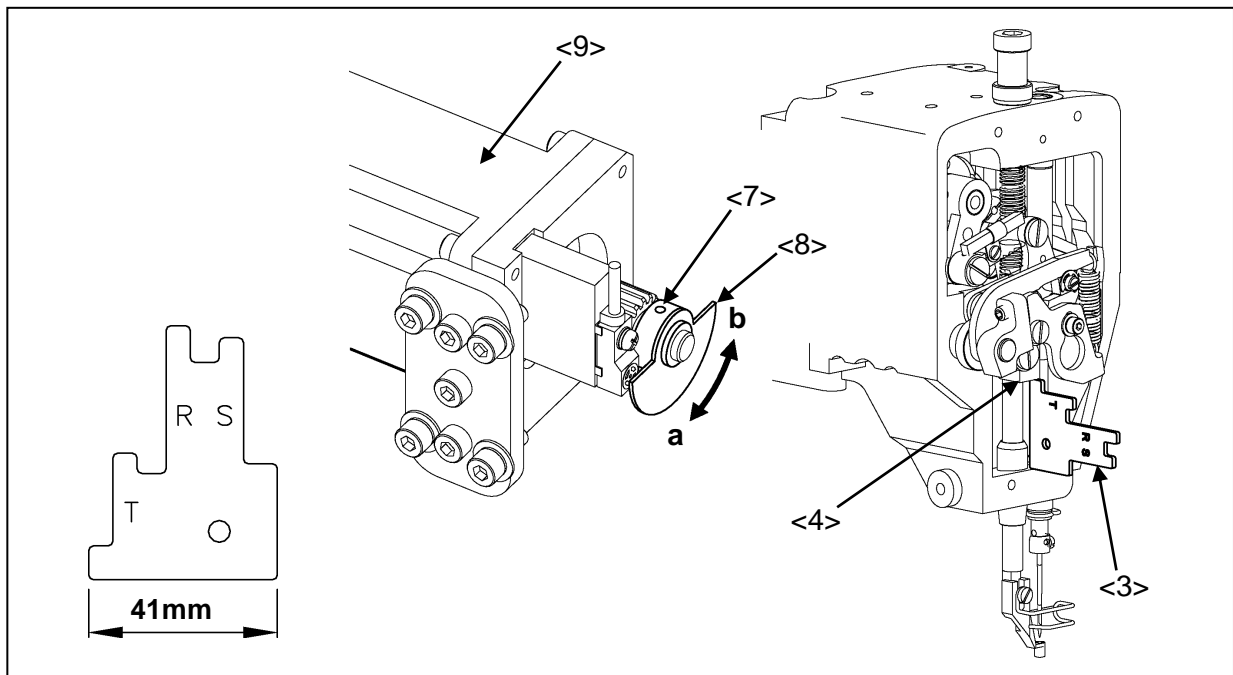

<3>: Gauge <4>: Presser foot bar holder <7>: Detector plate set screw
 <8>: Detector plate <9>: Presser foot drive motor

7-8. Adjustment of the presser foot height position

The height of presser foot can be returned factory default setting as the procedure shown below.

(1) Turn the power switch on, and set the correction value at 0. (*1)

For details, refer to the instructions in the paragraph “[8] Controlling the Presser Foot” in the **OPERATION PANEL** technical manual.

(2) Press the  on the standard screen and lower the presser foot.

(3) Turn the hand pulley and place the needle bar at the lowest position.

(4) Loosen the presser foot bar set screw (No.1) and adjust the clearance between the presser foot and slide plate to be 0mm and then, tighten the screw (No.1).

(5) The correction value is set at 3 as the factory default.

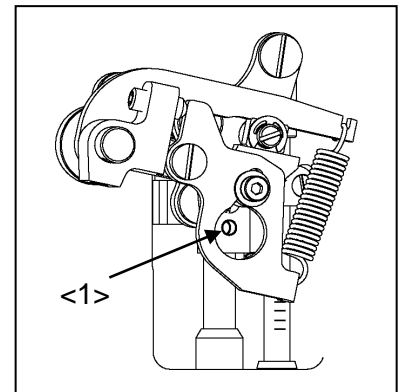

<1>: Presser foot bar set screw

*1: When changing the correction value at 0, an error message;

“ M-096: OVER LIMIT OF PRESSER FOOT STROKE “ may show up. This happens when the presser foot stroke is already set to the sewing data and by changing the correction value, the stroke in sewing data becomes 0mm or less. In that case, make new sewing data without the presser foot stroke or read out a sewing data that the stroke does not become 0mm or less.

7-9. Adjustment of the presser foot position

The presser foot lift during the sewing can be adjusted from 0 to 8mm. For details, refer to the instructions in the paragraph “[8] Controlling the Presser Foot” in the **OPERATION PANEL** technical manual.

[Notice] When using the long cylinder type of the presser foot, the correction value and the stroke are restricted.

7-10. Adjustment of the presser foot walk during the sewing

(1) The presser foot walk during the sewing can be adjusted with the walk at zero or the walk of 2 to 10mm.

The walk at zero requires the exclusive parts (Option).

Please feel free to contact your dealer.

(2) When turning the set position of the shoulder bolt (No.1) to the direction "a", the presser foot walk becomes bigger, and when turning the set position to the direction "b", the presser foot walk becomes smaller.

(3) To adjust the walk in 2 to 4mm, connect the link (No.2) with the screw hole A and adjust with the method (2) described above.

(4) To adjust the walk in 4 to 10mm, connect the link (No.2) shown on the figure and adjust the method (2) described above.

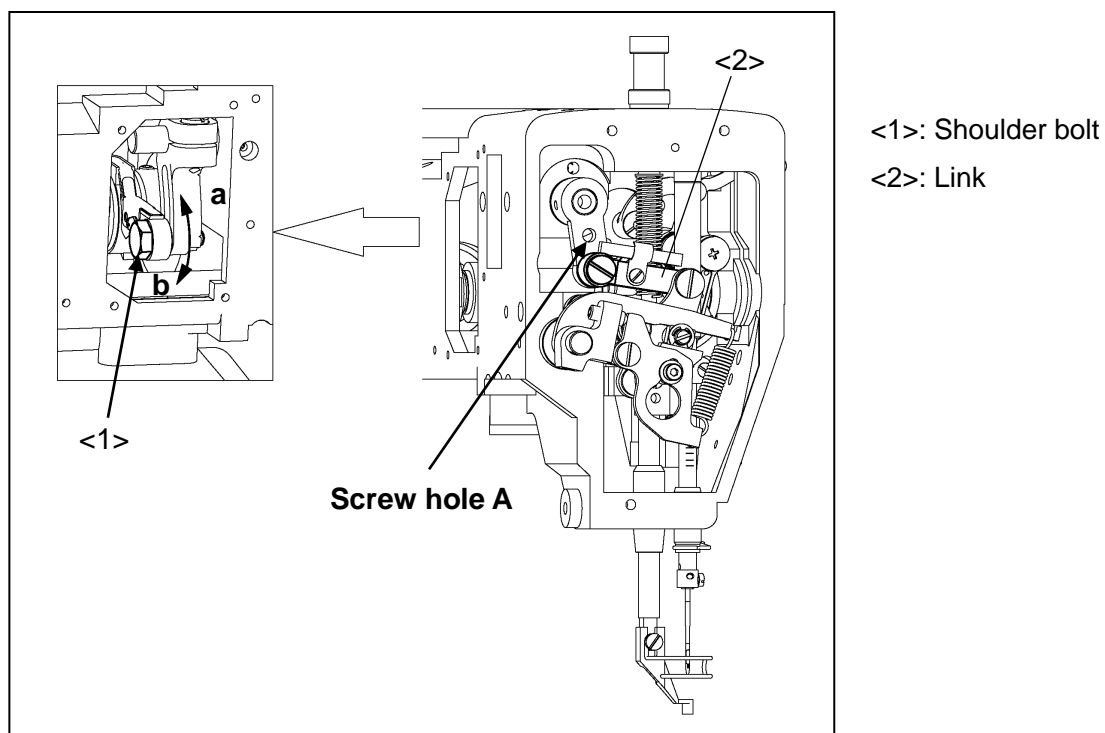

7-11. Adjustment of the presser foot spring pressure

The presser foot spring pressure can be changed with the following two methods.

(1) To increase the spring pressure, remove the face cover and loosen the bolt (No.1) then, adjust the spring A (No.3) pressure with the adjust screw (No.2). After the adjustment, tighten the bolt (No.1).

(2) To fine-tune the spring pressure, loosen the nut (No.4) then, turn the thumb screw (No.5) to adjust the spring B (No.6) pressure.

<1>: Bolt <2>: Adjust screw <3>: Spring A
 <4>: Nut <5>: Thumb screw <6>: Spring B

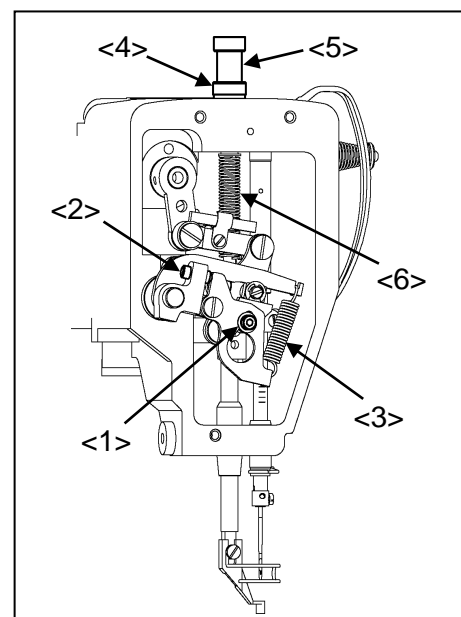

7-12. Adjustment of the wiper

- (1) Loosen the wiper setscrew (No.3) and adjust the wiper (No.1) to be positioned where the wiper (No.1) passes under the needle (No.2) point with a clearance of about 2mm right after the sewing machine stops at the needle upper position.
- (2) When setting the presser foot (No.4) to upper position during the sewing of thick material, the setting may not leave the clearance of passing wiper. The wiper cannot be used in this case.
- (3) The wiper does not work enough, loosen the wiper adjust screw (No.5) and adjust the wiper position.

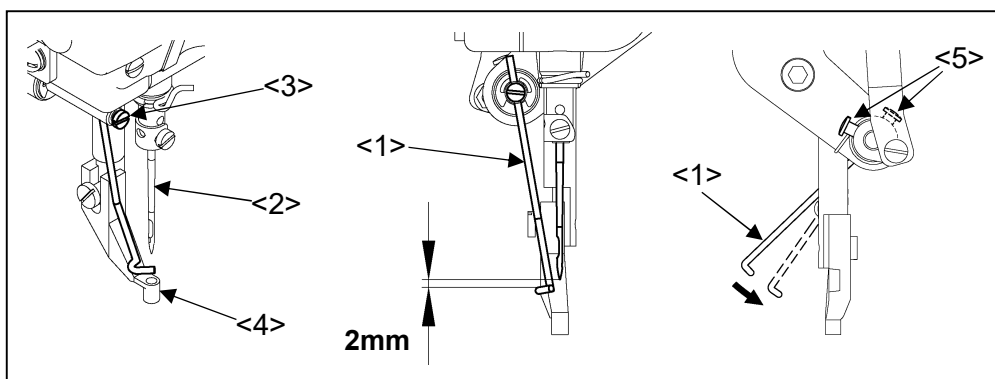



- <1>: Wiper
- <2>: Needle
- <3>: Wiper setscrew
- <4>: Presser foot
- <5>: Wiper adjust screw

- (4) When the wiper function is not be used (not able to be used), set the following.

Set the wiper function to off.

Press the  on the standard screen to open the MENU mode.

- (5) Press the  ->  ->  [Wiper ON/OFF] in order.

- (6) Select the  on the [Wiper ON/OFF] screen, and press the .

7-13 Adjustment of the work holder pressure



CAUTION

★If the secondary side air pressure is set too high, trouble such as operation faults may occur. Always set the pressure to within 0.4MPa.

- (1) The work holder pressure is provided from an air source.
Lift and turn the air regulator's adjustment knob (No.1) located under the table to adjust the air pressure.
- (2) If turn the adjusting knob (No.1) to the clockwise, the air pressure is increased and the work holder pressure is also increased simultaneously.
- (3) If turn the adjusting knob (No.1) to counter clockwise, the air pressure is decreased and the work holder pressure is also decreased simultaneously.
- (4) 0.4MPa (4kgf/cm²) is the standard air pressure as a normal sewing operation.

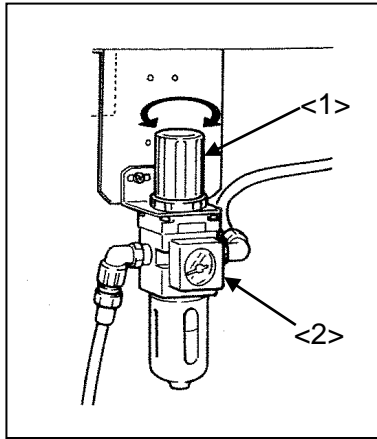

<1> : Adjusting knob
 <2> : Air regulator

7-14 Changing the work holder

- (1) Remove the work holder (No.1) by pressing it down from the engaged area with the pin (No.2) of the clamp adapter.
- (2) Prepare another work holder and securely engaged its U shaped mortise (No.3) with the pin (No.2) of the clamp adapter.

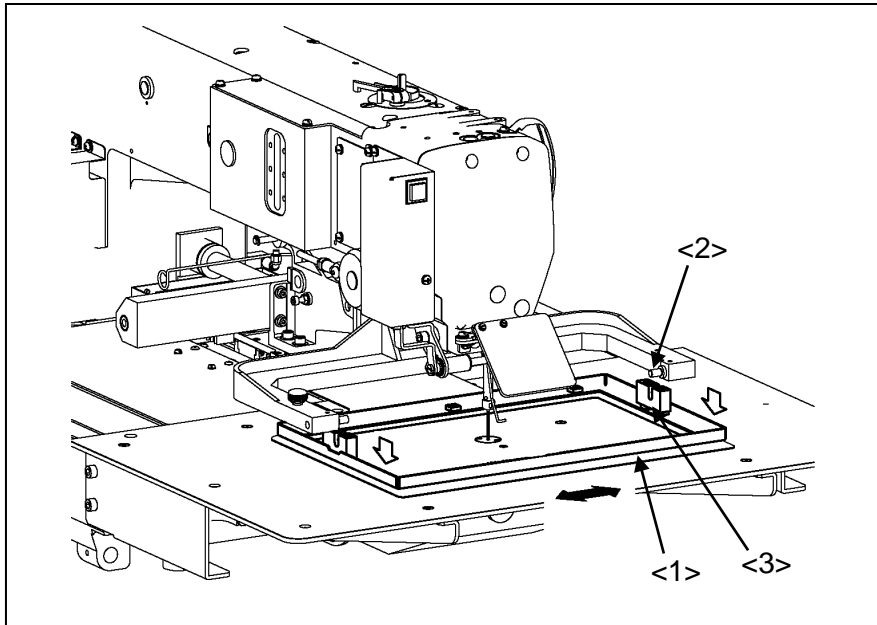

<1>: Work holder
 <2>: Pin
 <3>: U shaped mortise

7-15. Adjustment of the trimmer cam follower

- (1) Turn the power switch off and remove the top cover.
- (2) Loosen the arm set screw (No.3) to adjust the cam follower (No.1) with a cam groove clearance of about 1mm between the cam follower and the trimmer cam (No.2).
- (3) Loosen the nut (No.4) for turning the adjust screw (No.5).
- (4) Turn the pulley so that the needle bar moves to the lowest position.
- (5) Push the cam follower arm (No.1) to the arrow direction "A" and put the cam into the cam groove of the trimmer cam (No.2).
- (6) When tightening the adjust screw (No.5) in the condition described above, the cam follower is pushed into the cam groove then, the cam follower arm (No.1) is not returned even when releasing the cam follower arm .
- (7) When loosening the adjust screw (No.5) to the point "a" shown on the figure, the cam follower arm (No.1) goes back to the position in the direction "B"
Loosen the nut (No.4) from the point "a" to "b", 90-degree turns, and then fix the adjust screw (No.5).

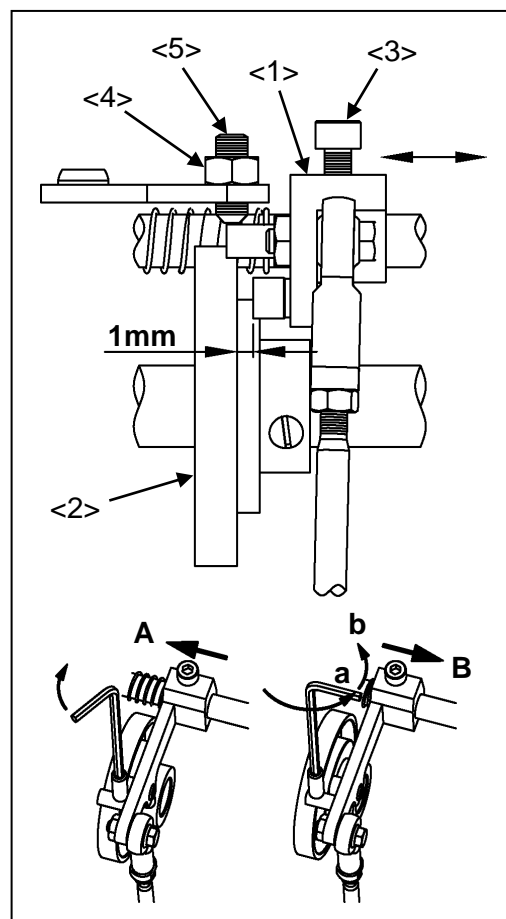

<1>: Cam follower arm <2>: Trimmer cam
<3>: Arm set screw <4>: Nut <5>: Adjust screw

7-16. Adjustment of the position for movable knife

- (1) Tilt the sewing machine head and open the cylinder cover.
- (2) Check the movable knife (No.1) whether the movable knife is at the standard home position 0.5mm far from the front face of the shuttle hook retainer (No.2).
- (3) For the adjustment of the movable knife point, loosen the hexagon head bolt (No.3) and move the horizontal thread trimmer rod (No.4) then, adjust the position of the movable knife point.

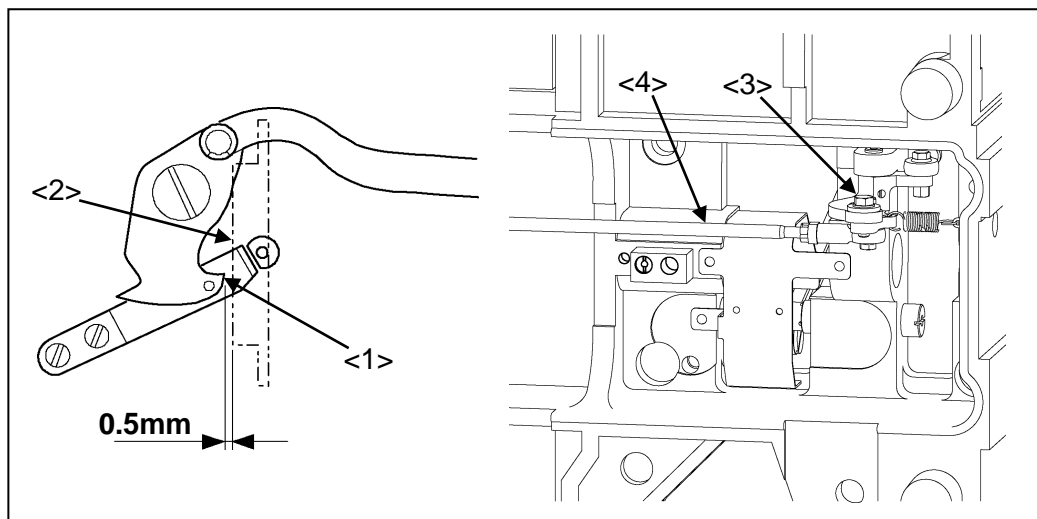

<1>: Movable knife <2>: Shuttle hook retainer <3>: Hexagon head bolt <4>: Horizontal thread trimmer rod

7-17. Adjustment of the fixed knife position

- (1) Open the cylinder cover (No.1) and remove the ring-E type (No.4), which engages the movable knife (No.2) and the thread trimmer link (No.3).
- (2) Loosen the screw (No.5) then, remove the slide plate (No.6).
- (3) Adjust the fixed knife (No.7) position to be positioned for the blade edge to have the clearance 0.5mm from the edge of the needle plate (No.8), which is standard position.
- (4) For the adjustment of the fixed knife (No.7) position, loosen the screw (No.9) and move the knife.

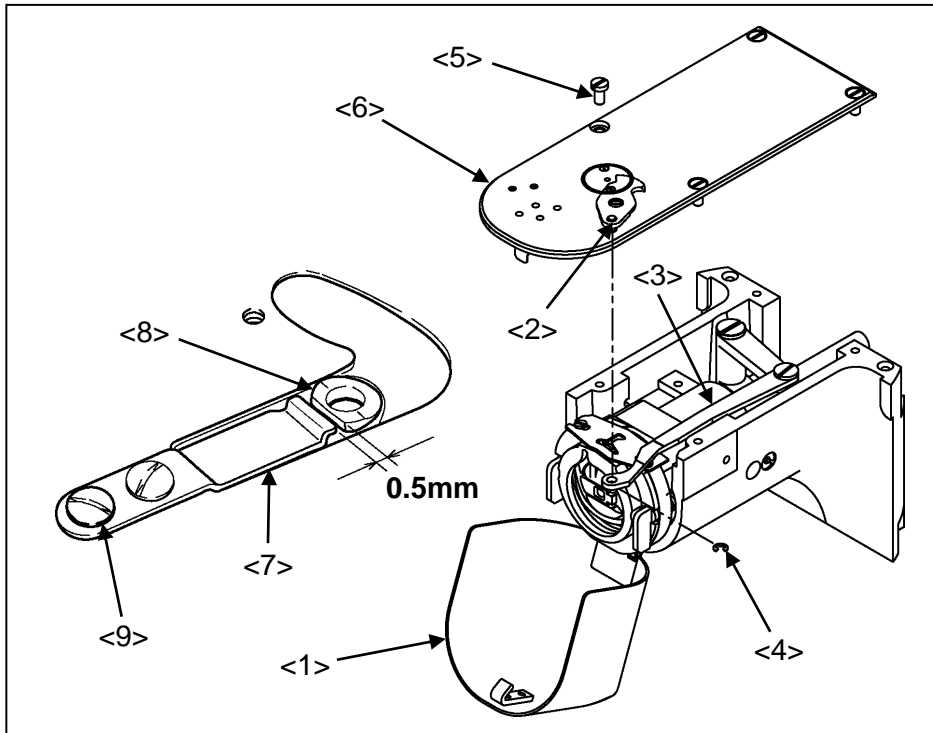

- <1>: Cylinder cover
- <2>: Movable knife
- <3>: Thread trimmer link
- <4>: Ring-E type
- <5>: Screw
- <6>: Slide plate
- <7>: Fixed knife
- <8>: Needle plate
- <9>: Screw

7-18. Adjustment of the thread take up spring

- (1) Loosen the set screw (No.2) and turn the whole thread tension regulator (No.3) then, adjust the thread take up spring (No.1) stroke to be in 9 to 10mm, which is standard stroke.
- (2) Insert the screw driver into the slit of the thread tension regulator and adjust the thread take up spring tension. When tightening the screw driver clockwise, the thread take up spring tension becomes tight, and when loosening the screw driver counterclockwise, the thread take up spring tension becomes loose. For the adjustment of the thread take up spring tension, tighten the set screw (No.2) so that the whole thread tension regulator does not turn.

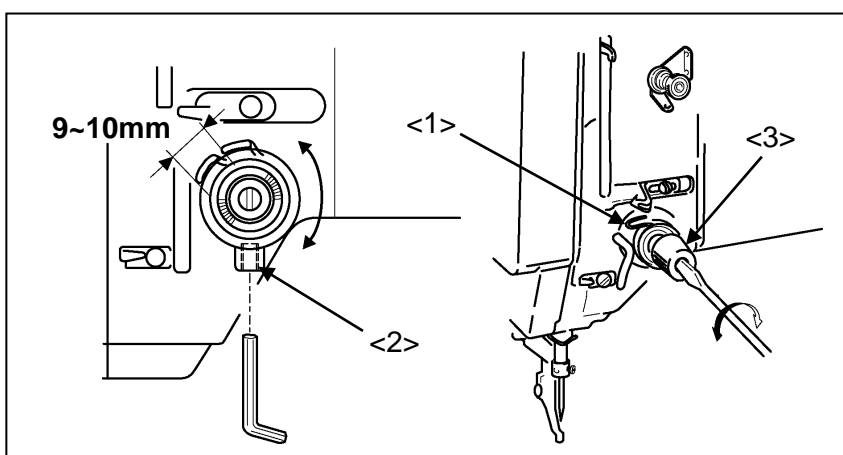

- <1>: Thread take up spring
- <2>: Set screw
- <3>: Thread tension regulator

7-19. Adjustment of the thread tail after the trimming

- (1) Adjust the thread tail with the pre-tension (No.1).
- (2) When turning the nut clockwise, the thread tail becomes shorter.
When turning the nut counterclockwise, the thread tail becomes longer.

<1>: Pre-tension

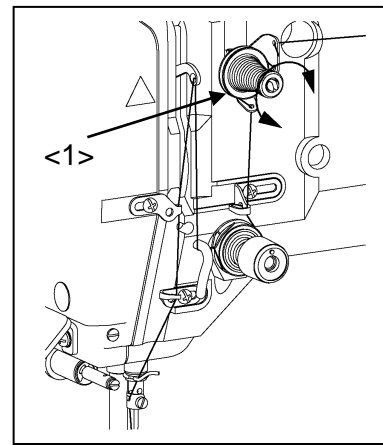

7-20. Adjustment of the upper thread tension release (the width between thread tension discs)



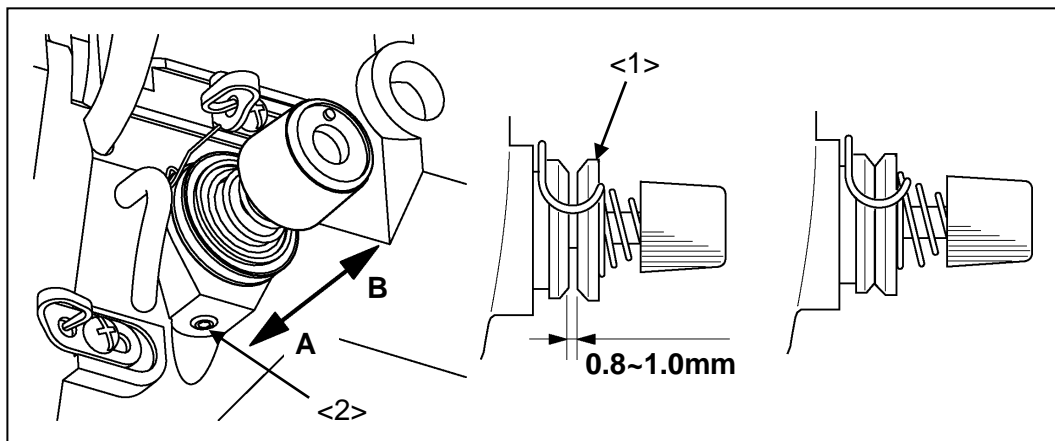



- (1) When the upper thread tension is released, the thread tension discs (No.1) open in 0.8mm to 1.0mm, which is standard width.
- (2) For the adjustment of the upper thread release, loosen the set screw (No.2) and move the whole upper thread tension release to the arrow direction as shown on the figure. When moving the upper thread tension release to the direction "A", the width between the discs becomes bigger.

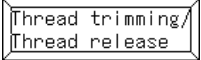

<1>: Thread tension disc <2>: Set screw

7-21. Adjustment of the opening time of the upper thread tension release disks

When the presser foot rises, the thread tension disks are open for a given length of time and close. The default setting is set at one-minute intervals. To change the set value, carry out the procedure shown below.

- (1) Turn the power switch on.
- (2) Press the  on the standard screen to open the MENU mode.
- (3) Press the  ->  ->  [Setting for tension release outputs time length at presser] in order.
- (4) Current set value is "60 sec".
- (5) Change the value from 0 to 10000 then press the .
- (6) Press the  -> . Changing set value has been completed.



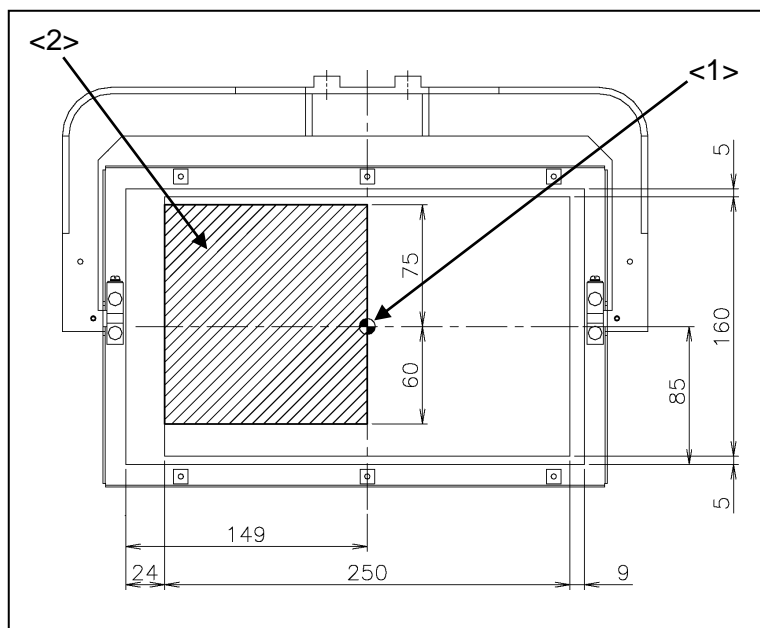

7-22. Adjustment of the X-Y mechanical home position

The mechanical home position (No.1) is fixed at the center of the sewing area as the factory default setting. The machine can be moved within the area (No.2) covered with diagonal lines.

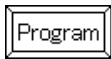
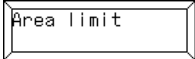

<1>: Home position as the factory default



<2>: Adjustable area

- (1) After canceling the sewing area limit, change the mechanical home position.
- (2) Press the  on the standard screen to open the MENU mode.
- (3) Press the  ->  ->  [Cancellation of sewing area limit] in order.
- (4) Select the  on the [Cancellation of sewing area limit] screen, and press the .
- (5) When turning the power off then, the setting of the sewing area limit is cancelled.

7-22-1. Adjustment of the X direction

- (1) Turn the power switch off.
- (2) Remove the covers on the top of the sewing machine bed.
- (3) The mechanical home position of the X direction is the position where the detector (No.2) can detect the edge of the detector plate X (No.1).
- (4) For the adjustment of the X direction mechanical home position, loosen the detector plate set screws (No.3) at the left and right side then, move the detector plate X in the arrow direction as shown on the figure. Set the clearance between the detector plate X and the detector within the range of 1.0 to 1.5mm.
- (5) Turn the power switch on. Press the home position return icon , and check the mechanical home position.
- (6) If the mechanical home position is not the desired position, carry out the same procedure (4) and (5) again. In that case, turn the power switch off each time.

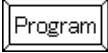
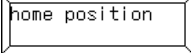
[Notice] The machine has a function that the motor memorizes the home position at the first home position returning operation after the switch is turned on. Therefore, from the second home position returning, it does not use the home position return sensor. Make sure to turn the power switch off to change the mechanical home position.

To use the sensor from the send returning, press  →  → 
 [Home returning method since the second time returning] on the standard screen and set it ON.

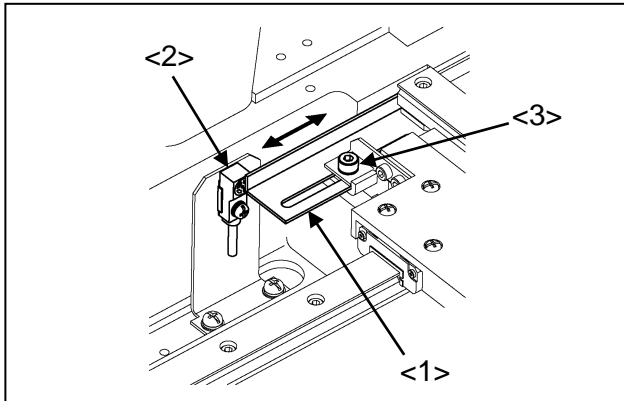



- <1>: Detector plate X
- <2>: Detector
- <3>: Detector plate set screw

7-22-2. Adjustment of the Y direction

- (1) Turn the power switch off.
- (2) The mechanical home position of the Y direction is the position where the detector (No.2) can detect the edge of the Y drive (No.1).
- (3) For the adjustment of the Y direction mechanical home position, loosen the detector set screw (No.3) then, move the detector to the arrow direction as shown on the figure.
- (4) Turn the power switch on. Press the home position return icon , and check the mechanical home position.
- (5) If the mechanical home position is not the desired position, carry out the same procedure (3) and (4) again. In that case, turn the power switch off each time.

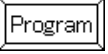
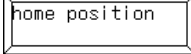
[Notice] The machine has a function that the motor memorizes the home position at the first home position returning operation after the switch is turned on. Therefore, from the second home position returning, it does not use the home position return sensor. Make sure to turn the power switch off to change the mechanical home position.

To use the sensor from the send returning, press  →  → 
 [Home returning method since the second time returning] on the standard screen and set it ON.

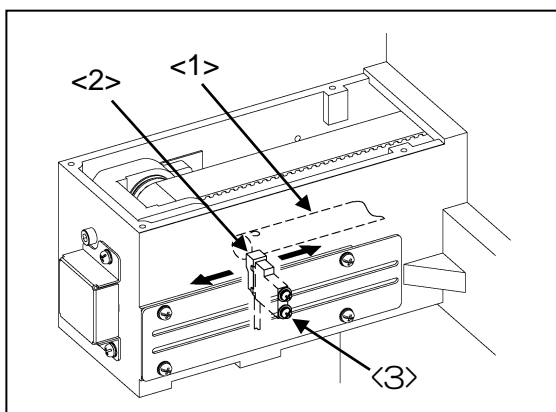

- <1>: Y drive
- <2>: Detector
- <3>: Detector set screw

7-23. The X-Y drive timing belt tension

The X-Y drive timing belt tension is as follows as the factory default setting.

X : 200 (N) ± 10% Y : 200 (N) ± 10%

8. MAINTENANCE



- (1) Please make sure to turn the power switch off before cleaning the sewing machine.
- (2) Please pay attention to that staining your skin or eyes with oil may cause an inflammation.

8-1. Cleaning

- (1) Remove the dust and the thread waste sticking the threading parts or the hooks area regularly.

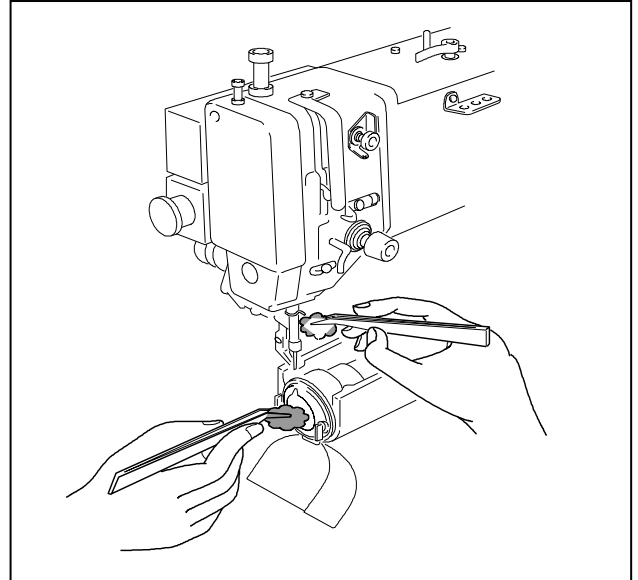

- (2) The dust or the like sticking the X-Y slide guide absorbs lubrication oil on the rails and significantly lowers the slide guide running life.

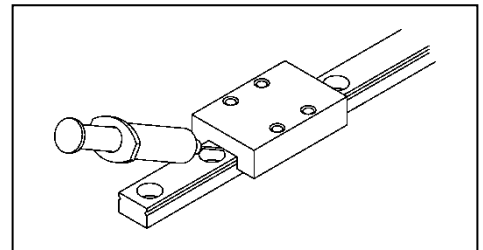

Clean the slide guide regularly and also pour some grease.

Recommended grease: Multemp PS2 (Produced by *Kyodo Yushi Co. Ltd*)

(Lithium grease 2)

8-2. Disposing of oil waste

If the waste oil pan is full filled in the oil bottle (No.1), remove the oil bottle then dispose of the waste oil.

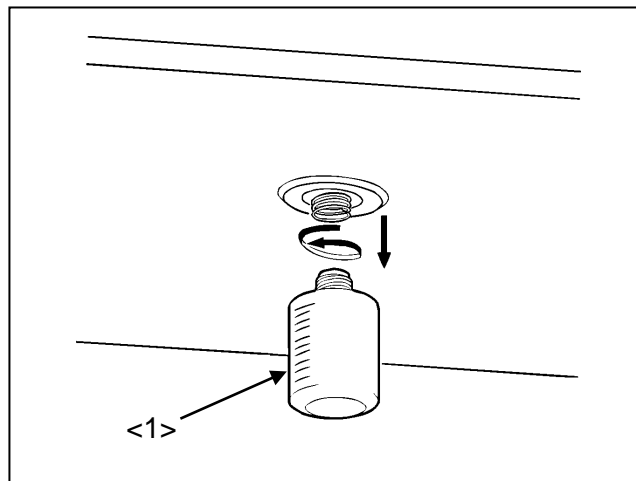

9. TROUBLESHOOTING



CAUTION

(1) Please make sure to turn the power switch off before adjusting the sewing machine.

(2) If the adjustment is required while the power switch on, do not step on the foot switch by mistake.

Condition	Cause	Corrective action	Reference
Upper thread is broken.	Upper thread tension is too tight.	Adjust thread tension.	6-3
	Strength of thread take up spring is inappropriate.	Adjust thread take up spring.	7-18
	Parts on needle plate, hook, and presser foot touching thread are damaged.	Grind parts or change parts.	-
	The needle size is bigger than the thread size.	Change the needle size to suitable size.	-
	Thread melts with heat.	Slow down the sewing speed	6-1
Use needle cooler.		-	
Bobbin thread is broken.	Bobbin thread tension is too tight.	Adjust thread tension.	6-3
	Parts on needle plate and presser foot touching thread are damaged.	Buff parts or change parts.	-
Upper thread is pulled from needle hole when starting sewing.	Thread tail is short.	Adjust thread tail with pre-tension.	7-19
	Thread take up spring tension is too much.	Adjust thread take up spring tension.	7-18
Frequent skip stitching happens.	Clearance between needle and shuttle hook is too big.	Adjust clearance between needle and shuttle hook properly.	7-3
	Timing of needle and shuttle hook is not proper.	Adjust position of needle and shuttle properly.	7-2
	Contact between needle and driver is too tight.	Adjust clearance between needle and driver properly.	7-4
	Needle is bent.	Change needle.	-
	Needle is at wrong position.	Fix position properly.	5-2
Trimming is not functioned.	Fixed knife is dull.	Sharpen fixed knife or change fixed knife.	7-17
	Movable knife is dull.	Change movable knife.	7-16

Trimming is not functioned.	Movable knife is at wrong position.	Adjust position of movable knife properly.	7-16
	Skip stitching happens in trimming.	Refer to the condition "Frequent skip stitching happens".	-
	Trimming setting is off.	Turn trimming setting on.	Operation panel section
Stitch forming is loose.	Upper thread tension is too loose.	Adjust upper thread tension.	6-3
	Bobbin thread tension is too loose.	Adjust bobbin thread tension.	6-3
	Strength of thread take up spring is inadequate.	Adjust strength of thread take up spring.	7-18
	Presser foot position is not proper.	Adjust presser foot position properly.	7-7,7-8 7-9
	Presser foot up and down timing is not proper.	Adjust presser foot up and down properly.	7-6
Stitch on back comes apart.	Thread is not divided with thread guide properly.	Adjust thread guide position.	7-5
	Needle thread is too long.	Adjust needle thread with pre-tension.	7-19
All switches do not work after turning power on.	Tilting detect switch is kept on.	Check tilting detect switch.	3-8
Work holder does not fall.	Foot switch is broken.	Change foot switch.	-
	Work holder presser is not strong enough	Increase work holder presser	7-13
	Work holder switch is out of order	Change it new work holder switch	-
Wiper system does not work.	Wiper hits needle or presser foot.	Adjust wiper position.	7-12
	Wiper setting is turned off.	Turn wiper setting on.	7-12
Sewing pattern is changed.	Sewing material is not pressed properly.	Adjust work holder pressure.	7-13
	Sewing material in work clamp slips.	Put slip stopper on presser plate.	-
	Sewing material is too heavy.	Slow down sewing speed.	6-1
	X-Y timing belt tension is loose.	Adjust X-Y belt tension properly.	7-23
Returned home position is changed.	Ambient temperature is out of use range.	Use sewing machine in ambient temperature in 5 degrees to 35 degrees.	-
	Clearance between detector and detecting subject is too wide.	Adjust clearance in 1 to 1.5mm.	7-22

APPENDIX

MEMO If the steel stand is not original, produce the parts with reference to the following drawings.

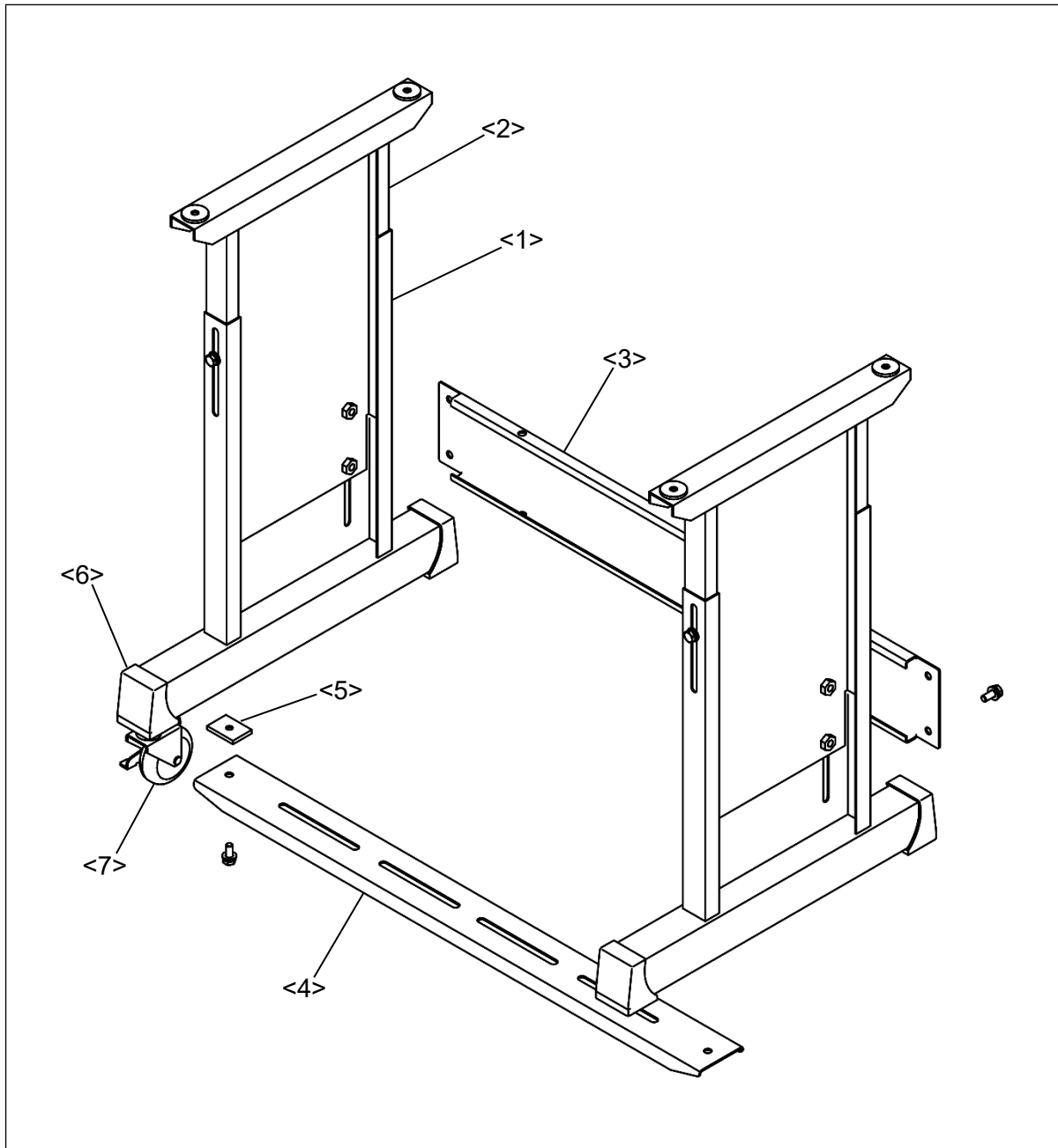

Stand part <1>...Thickness 2mm

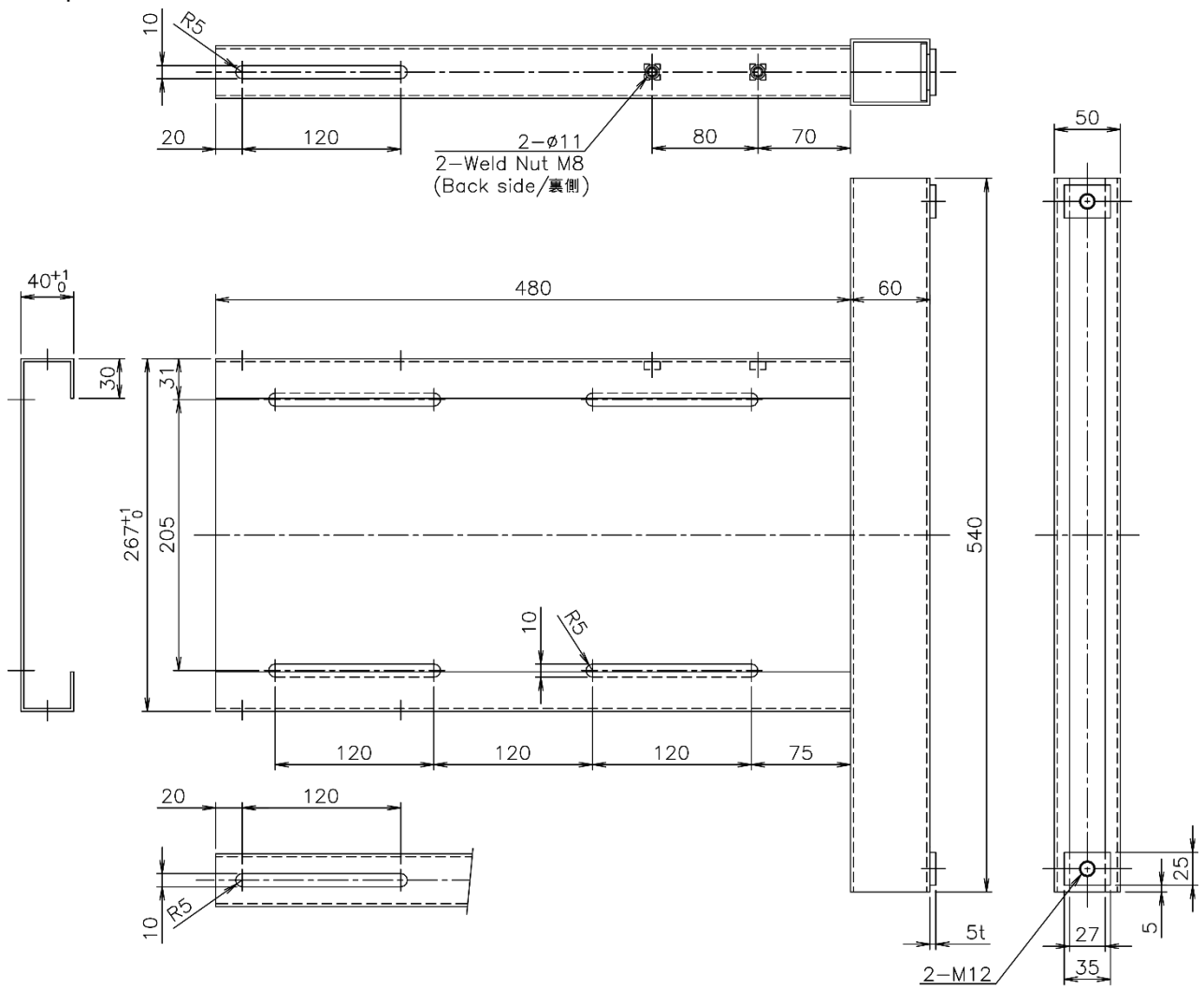

Stand part <2>...Thickness 2mm

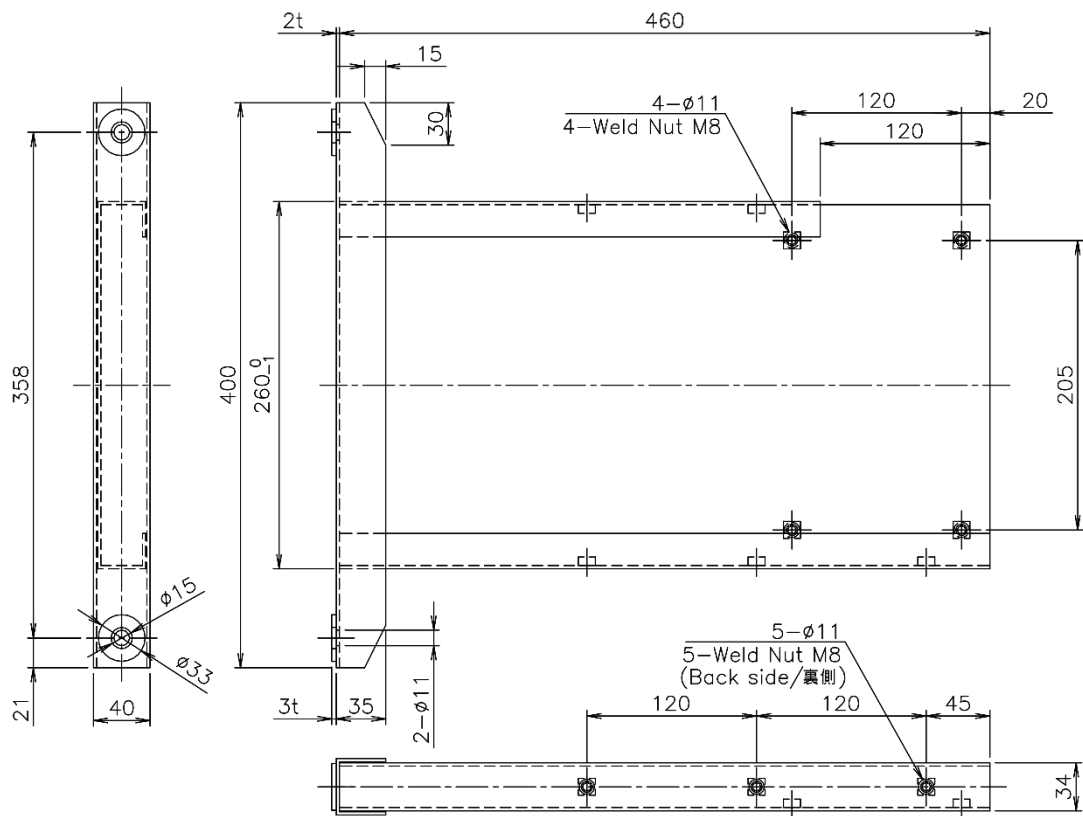

Stand part <3>...Thickness 2mm

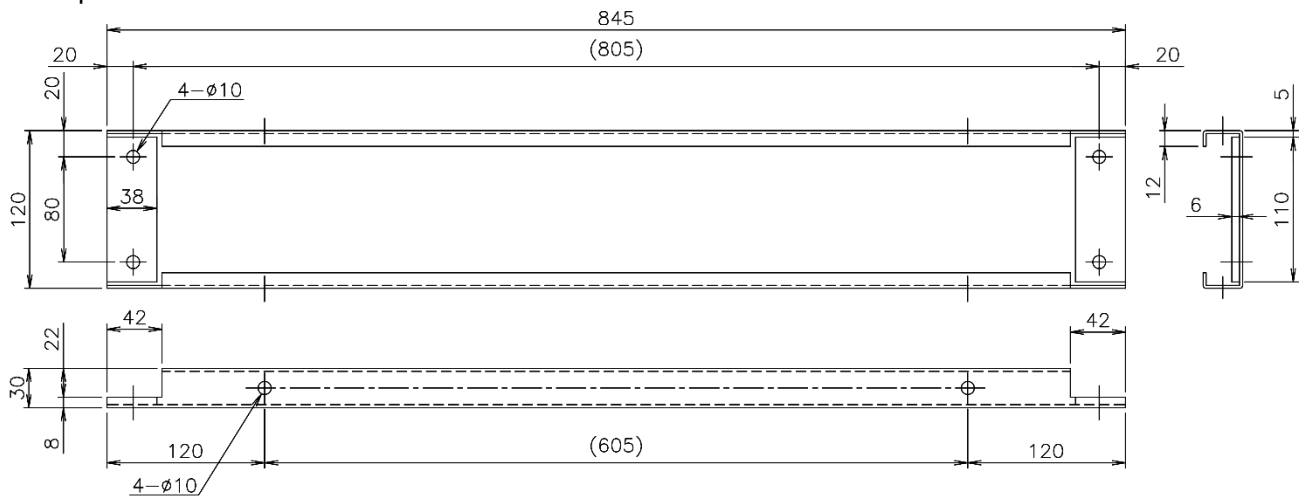

Stand part <4>...Thickness 2mm

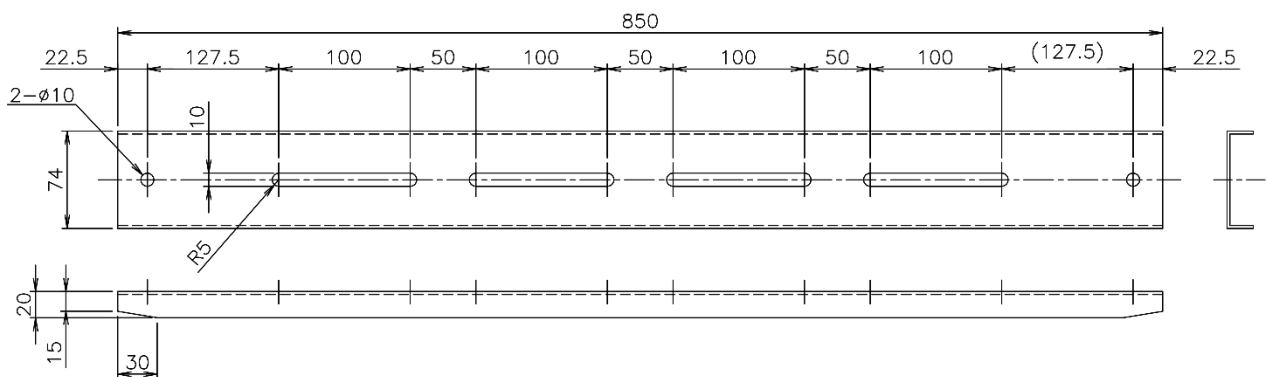

Stand part <5>...Thickness 5mm

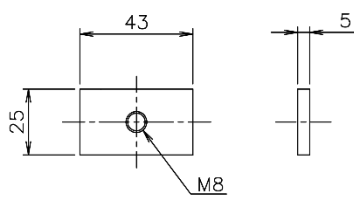

Stand part <6>...Rubber thickness 2.5mm

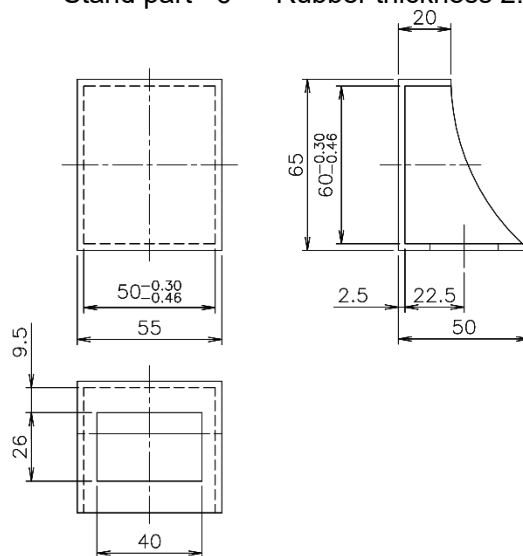

Stand part <7>...Permissible load more than 60kg
(Per wheel)

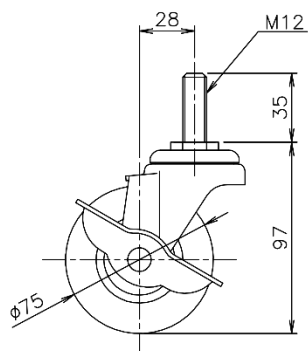

MEMO

A large rectangular area with a solid border, containing 25 horizontal dashed lines for writing.

MEMO

A large rectangular area with a solid border, containing 25 horizontal dashed lines for writing.

JUKI CORPORATION

Printed in Japan