

JUKI®

INDUSTRIAL SEWING MACHINE
Attachment

MODEL

MP-J25-PS

TECHNICAL MANUAL

PERFECT STITCH UNIT

FOR SAFE USE

Before the installation, operation, and inspection for this product, read the “FOR SAFE USE” and the technical manuals carefully. Also read the other technical manuals, “Control Unit” and “Operation Panel” describing some instructions, which are not in this manual, and use the sewing machine properly.

SAFETY INDICATIONS

	DANGER	Indicates that incorrect handling may cause hazardous conditions, resulting in death or severe injury.
	CAUTION	Indicates that incorrect handling may cause hazardous conditions, resulting in medium or slight personal injury or physical damage. Note that CAUTION level may lead to a serious consequence according to the circumstances. Always follow the instructions of both levels because they are important to personal safety.

CAUTION INDICATIONS

No.	Caution indication	Description
1		<p><u>Precaution for sewing machine operation:</u></p> <p>Indicates that removing the safety and operating the sewing machine for some other purposes with power-on are prohibited.</p> <ul style="list-style-type: none"> ● Please do not operate the sewing machine without protective equipment such as a needle guard, an eye guard, a belt cover or the others. ● Please turn off the power switch when threading, changing a needle and a bobbin, cleaning, and lubricating.
2		<p><u>Caution for fingers injury:</u></p> <p>Indicates a possibility of fingers (hands) injury in a certain condition.</p>
3		<p><u>Caution for squeezing fingers:</u></p> <p>Indicates a possibility of squeezing fingers in a certain condition.</p>

SAFETY PRECAUTIONS



To prevent from receiving an electric shock, always turn off a power switch and unplug power supply when opening a control box, and then open after ten minutes passes.



USAGE ENVIRONMENT

Please do not operate the sewing machine under the following conditions.

- (1) In the ambient temperature of 35 degrees (95°F) or more than 35 degrees, or the ambient temperature of 5 degrees or less than 5 degrees (41°F).
- (2) In the ambient temperature of 55 degrees (131°F) or more than 55 degrees, or the ambient temperature of -10 degrees or less than -10 degrees (18°F) during transportation.
- (3) In the relative humidity exceeding 85% or less than 45%.
- (4) In the open-air place or the location that receives direct sunlight.
- (5) In the place near heat sources such as heating devices.
- (6) In the atmosphere filled with dust, explosive gas, or corrosive gas.
- (7) In the place where the fluctuation in the power voltage of 10% or more than 10%, or the power voltage of -10% or less than -10% of the fixed power voltage.
- (8) In the place where the power source cannot supply enough voltage to keep the motor running.
- (9) In the place filled with strong electric noises such as high-frequency welders.

INSTALLATION

- (1) Please have some specialists, who have enough experience for the sewing machine installations, install the sewing machine.
- (2) Please have a qualified electrician perform necessary electric wiring.
- (3) Please do not operate until the sewing machine is repaired when any damage or fault is found on the sewing machine at the installation.
- (4) Please do not refurbish the sewing machine.
- (5) The sewing machine is heavy. For the safety, please make sure to install the sewing machine head by more than one person.
- (6) Please make sure to fit the safety protective equipment (the motor cover or the others) and the accessory protective equipment (the eye guard) that removed temporarily for installation.

SEWING

- (1) Please make sure to turn the power switch off before installing or replacing needles.
- (2) Please pay attention for the fingers not to be injured by the needle point.
- (3) Please make sure to turn power switch off before lubricating.
- (4) Please pay attention that oil does not get on your skin or in your eyes as it may cause an inflammation.
- (5) Please make sure to keep oil out of the reach of children who may drink oil by mistake.
- (6) Please make sure to turn the power switch off before threading a needle.
- (7) Before starting the sewing, please make sure the position and the function of the halt switch.
- (8) Please do not touch the operating parts during sewing operation.
- (9) Do not operate the perfect stitch device that has been without safety device such as injury prevention cover and area sensor. These are to be supplied by customer.
- (10) Please make sure to turn the power switch off when stopping the sewing machine temporarily.

ADJUSTMENT

- (1) Please make sure to turn the power switch off before adjusting the sewing machine.
- (2) If the adjustment is required while the power switch on, do not step on the foot switch by mistake.
- (3) Please be careful not to be injured by a sharp part such as the needle and the shuttle hook point.
- (4) Please make sure to put the safety guards (eye guards, belt guards, link covers, and finger guards or the others) back on the initial position after the sewing machine adjustment.
- (5) Do not touch the clamp rotation mechanism that are the clamp, turn table and rotation drive unit during the machine power ON.
To prevent the unexpected operation, do not move the clamp rotation mechanism by hand during the machine power ON.

CONTENTS

1. STRUCTURE OF THE SEWING MACHINE	1
2. SPECIFICATIONS	2
2-1. Specifications	2
2-2. Positional relations of the machine and sewing area and clamp	3
3. INSTALLATION	4
3-1. Removing the unnecessary work holder unit and cover component	4
3-2. Removing the various cover	6
3-3. Installation of the rotation drive unit adapter	6
3-4. Installation of the support bracket	7
3-5. Installation of the thread take up spring stopper	8
3-6. Installation of the slide plate	9
3-7. Installation of the support bracket	10
3-8. Installation of the base bracket	11
3-9. Installation of the perfect stitch unit (Installation of the motor drive unit)	12
3-10. Installation of the perfect stitch unit (Installation of the clamp rotating unit)	14
3-11. Adjustment of the timing belt tension	17
3-12. Installation of the turn table unit	18
3-13. Installation of the θ axis sensor unit	19
3-14. Connection of the electric cables	20
3-15. Installation of the θ axis motor cover	23
3-16. Installation of the XY cover	24
3-17. Installation of the various cover	24
4. INITIAL SETTING	25
4-1. Installation of the system	25
4-2. How to operate jig clamp	25
4-3. Initial adjustment of turn table home position	26
4-4. Initial adjustment of rotation home position	31

5. PROPER OPERATION (CLAMP ROTATION)	33
5-1. Outline	33
5-2. Basic operation of clamp rotation	33
5-3. Clamp rotation details	36
6. MAINTENANCE	37
6-1. Cleaning	37
6-2. Greasing	37

APPENDIX 1. Program mode list

APPENDIX 2. Parts catalog

APPENDIX 3. Dimensional drawing of slide plate

1. STRUCTURE OF THE SEWING MACHINE

MP-J25-PS (Perfect stitch unit) consists of the following main parts.

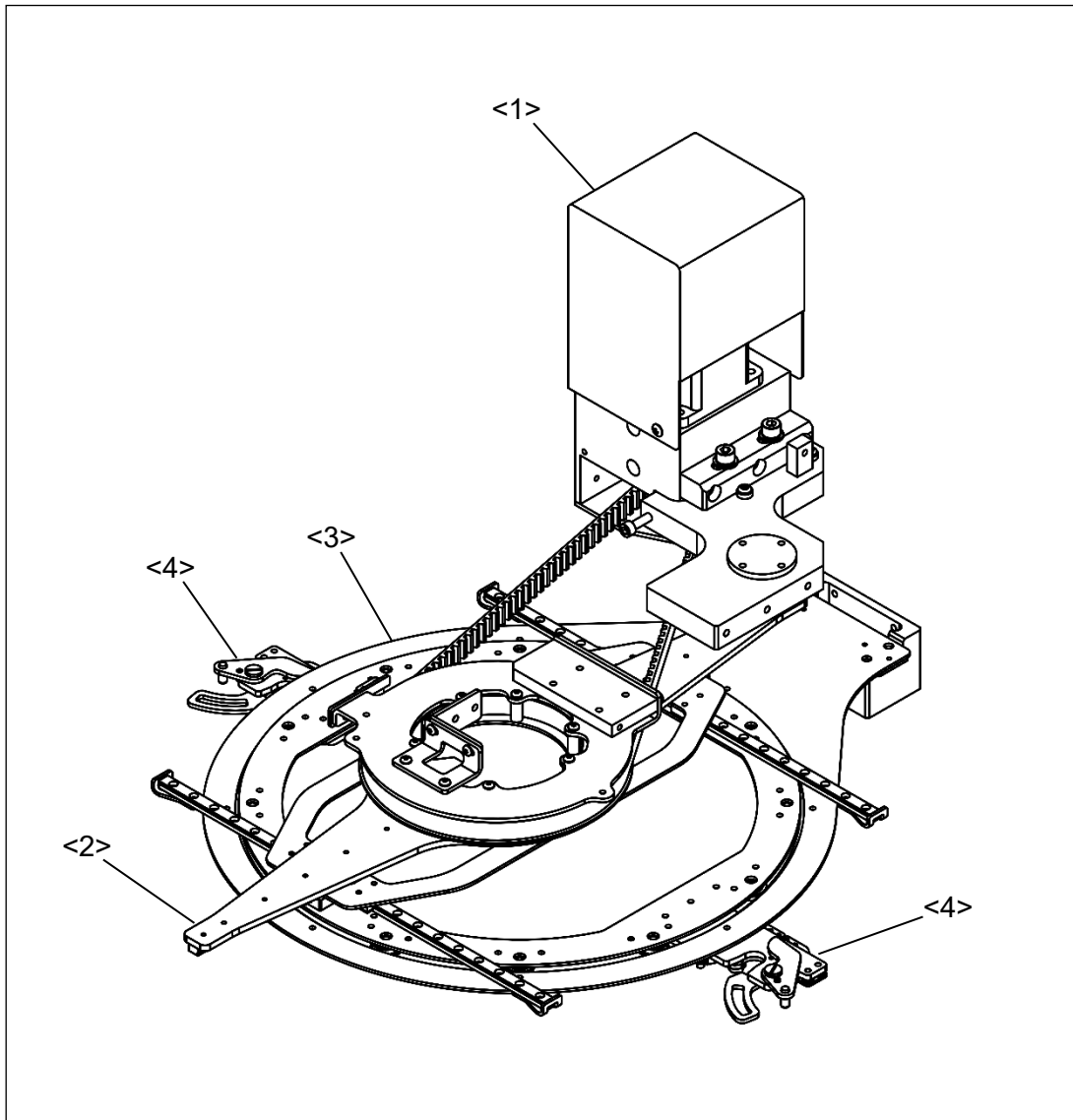

<1>: Motor drive unit <2>: Clamp rotating unit <3>: Turn table unit

<4>: Jig clamp unit

2. SPECIFICATIONS

2-1. Specifications

Model	MP-J25-PS
Applicable model	PLK-J2516R-YU
Sewing area *1	X-direction (left/right) 140 mm
	Y-direction (front / back) 140 mm
Maximum sewing speed *2	1,000rpm
Setting speed	10 speed levels in 200 rpm to 1,000 rpm
Work holder type	Jig eject system (Manual eject type)

*1: Sewing area stated on the basis of the area limit default value. For more details, please see next section.

*2: Sewing speed may be limited by the operation or sewing condition.

3. INSTALLATION



- (1) Please have some specialists, who have enough experience for the sewing machine installations, install the sewing machine.
- (2) Please have a Qualified Electrician perform necessary electric wiring.
- (3) Please do not operate until the sewing machine is repaired when any damage or fault is found on the sewing machine at the installation.
- (4) Please do not refurbish the sewing machine.

Install this device according to following procedures. Attaching screws which explains this manual are included in this devices package. Before installing, check if the sewing machine is in the condition suitable for proper sewing.

3-1. Removing the unnecessary work holder unit and cover component

- (1) Remove the needle and presser foot.
- (2) Remove each four of M5 screw <3>, washers <4> and each four of M4 screws <5>, washers <6> then remove the work holder unit <1>.
- (3) Remove each two of M5 screws <7>, washers <4> and remove the feed plate <2>.
- (4) Remove the air piping for work holder then, attach the plug to the solenoid valve. Plug is included in this devices package.

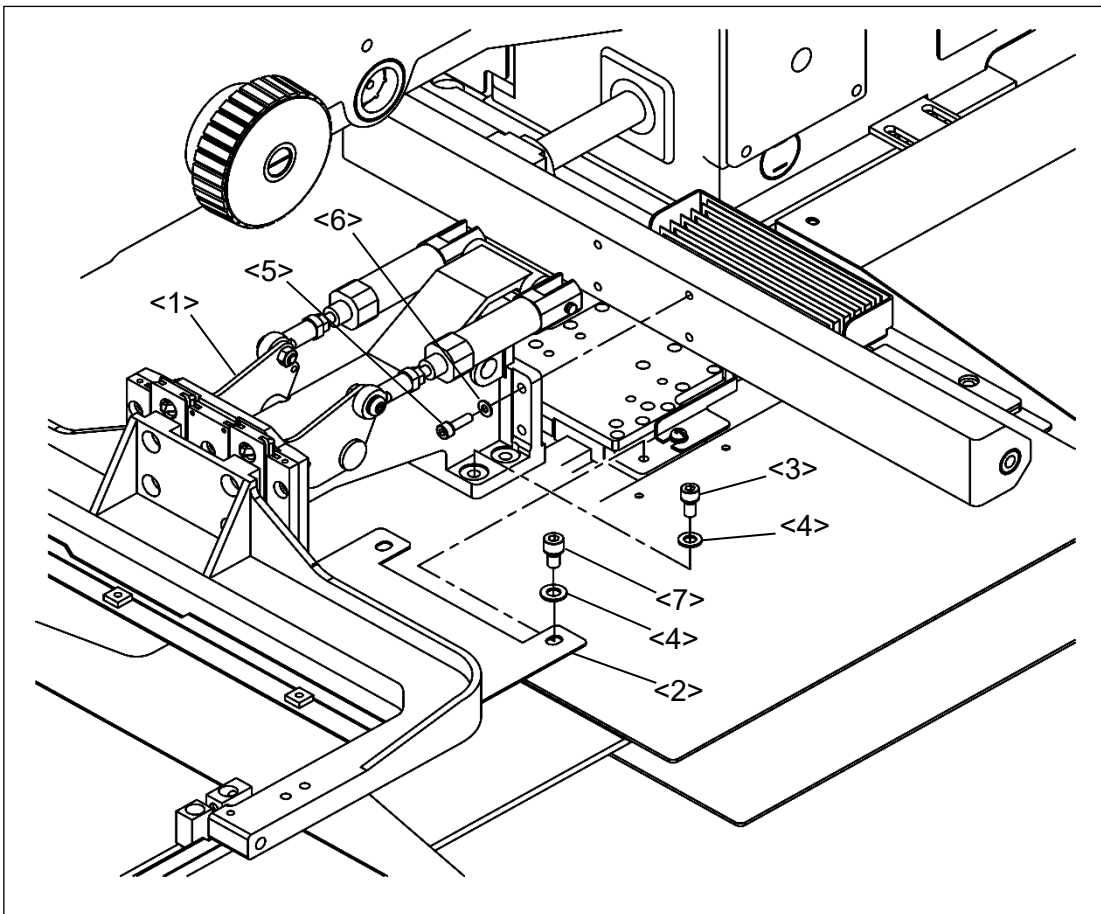

<1>: Work holder unit <2>: Feed plate <3>: M5 screw <4>: Washer 5
<5>: M4 screw <6>: Washer 4 <7>: M5 screw

(5) Remove twelve of screws <2> and remove the slide plate <1>.

(6) Remove two of screws <4> and remove the mounting plate <3>. Remove the opposite side of mounting plate by same procedure.

(7) Remove three of screws <8> and remove the X cover plate (right) <6>, X movable plate (right) <7> and spacer <5>. Remove the X cover plate (left), X movable plate (left) and spacer by same procedure.

Note These covers are needed to attach again after finish of installing the perfect stitch unit. However, X cover plate (left and right) and screws <8> are needed to change to other parts which included in this devices package. Please refer to the paragraph [3-16].

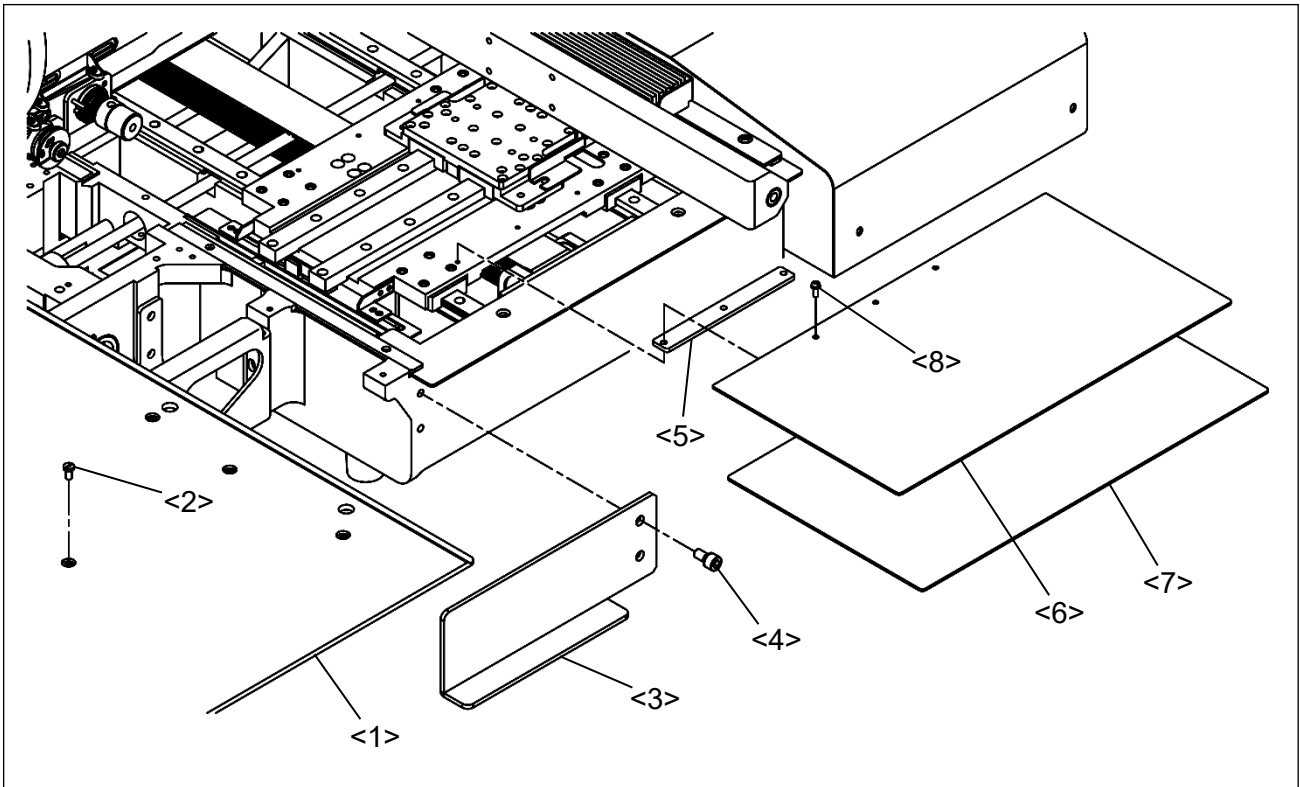

<1>: Slide plate <2>: Screw <3>: Mounting plate <4>: Screw <5>: Spacer
<6>: X cover plate (right) <7>: X movable plate (right) <8>:Screw

(8) Remove two of screws <10> and remove the cover <9> which attached on the bottom of machine arm.

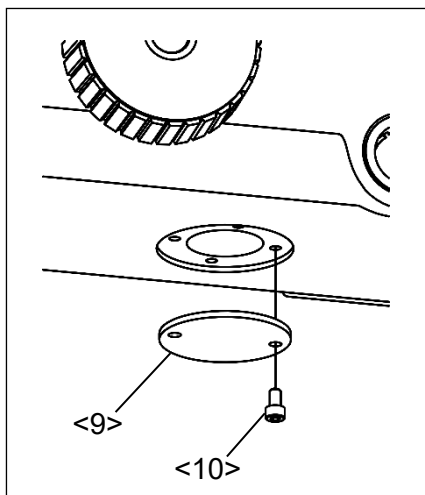

<9>: Cover
<10>: Screw

3-2. Removing the various cover

(1) Remove the screws <4> and remove the each covers which are X-Y motor cover <1>, side cover <2> and head cover <3>. These covers are needed to attach again after finish of the cable wiring.

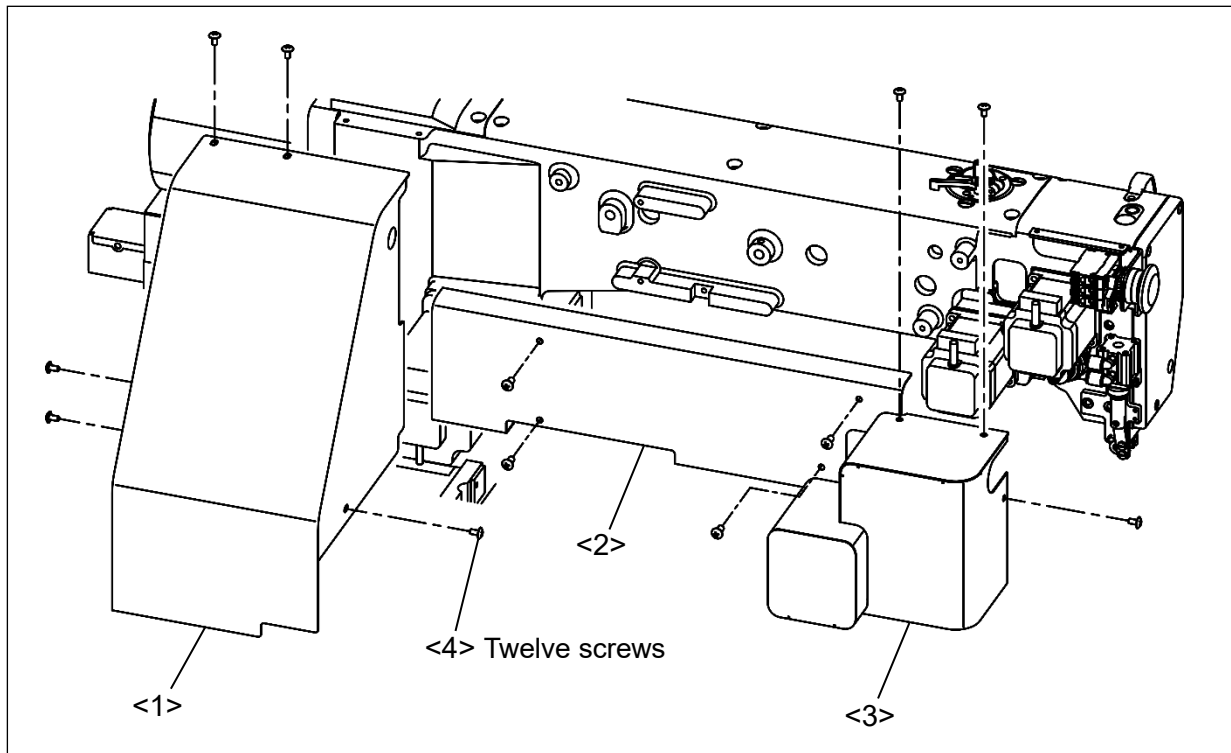

<1>: X-Y motor cover <2>: Side cover <3>: Head cover <4>: Screw

3-3. Installation of the rotation drive unit adapter

(1) Remove four of screws <3> which fixing the digital tension unit <1> and install the adapter <2> with four of screws <4>. Install the adapter <2> by referencing following figure.

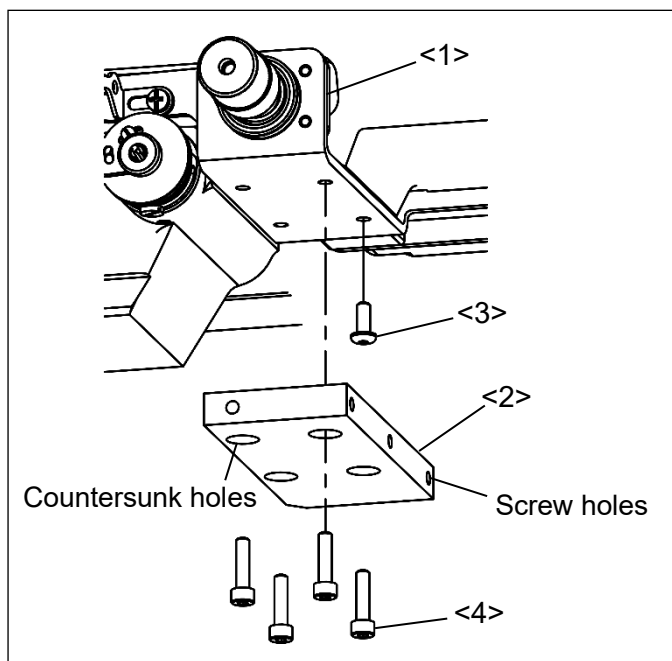

<1>: Digital tension unit
<2>: Adapter
<3>: Screw
<4>: Socket bolt (M4X16)

3-4. Installation of the support bracket

- (1) Remove the existing screws which fixing wiper unit. Install the support bracket <1> together with wiper unit <2> with each two of screws <3> and washers <4>. Fix the support bracket and wiper unit with two screws <5>.
- (2) If not use wiper unit, in this case install the support bracket <1> directly to the machine head with two screws <6>.

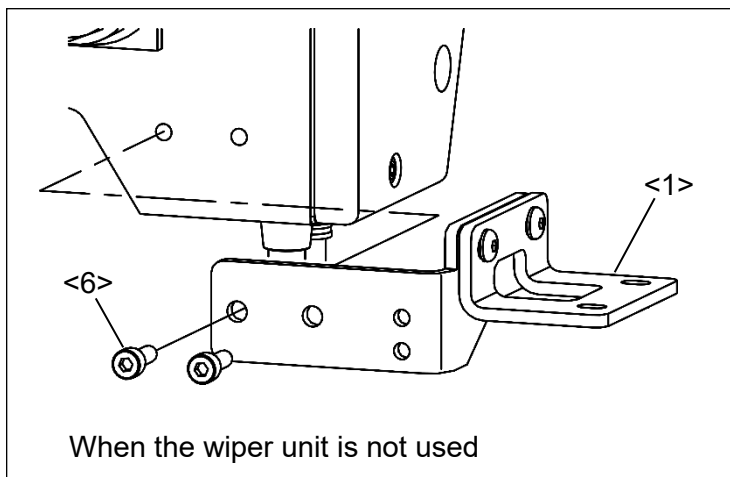
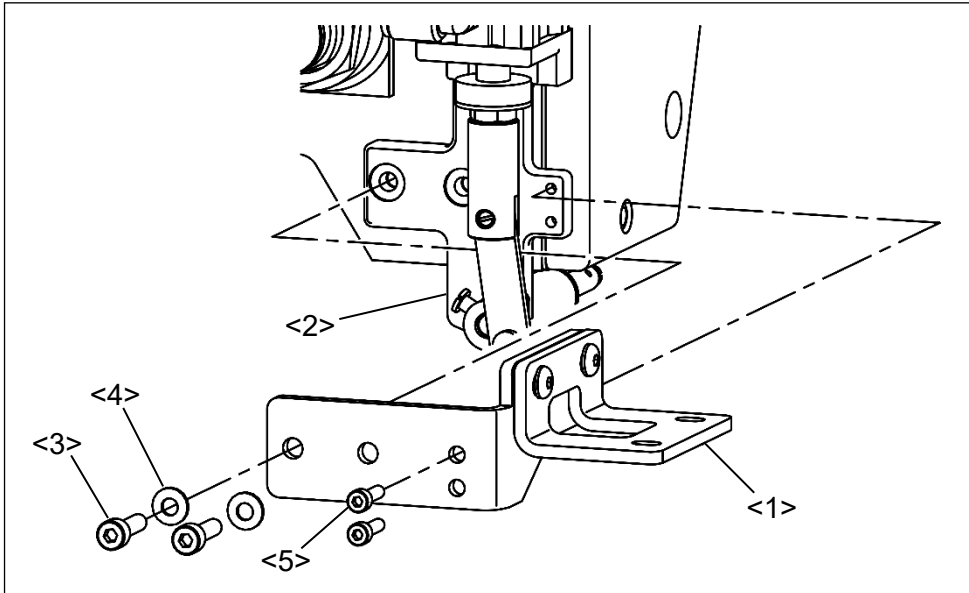

- <1>: Support bracket <2>: Wiper unit <3>: Screw (Socket bolt M4X16)
<4>: Washer (Large washer 4) <5>: Screw (Socket bolt M3X6)
<6>: Screw (Socket bolt M4X10)

3-5. Installation of the thread take up spring stopper

According to the following procedures, remove the existing thread take up lever stopper <1> and install the stopper <4>. The stopper <4> is included in this devices package.

(1) Remove the screw <2> and remove the stopper <1>.

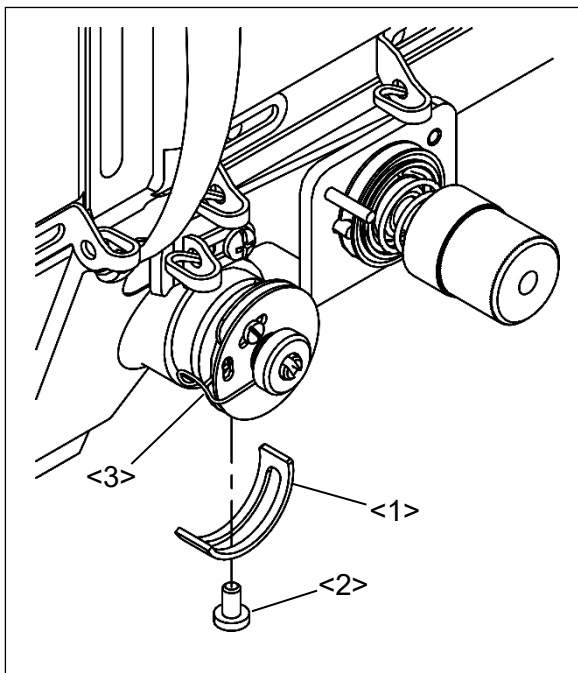

- <1>: Stopper
- <2>: Screw
- <3>: Thread take up spring

(2) Remove the thumb screw <10>, screw <9>, thread guide <8>, screw <7>, base plate <6> then, fit the stopper <4> to the "A" marked portion of machine head and fix it with screw <5>. And then back the base plate <6>, screw <7>, thread guide <8>, screw <9>, thumb screw <10> in order.

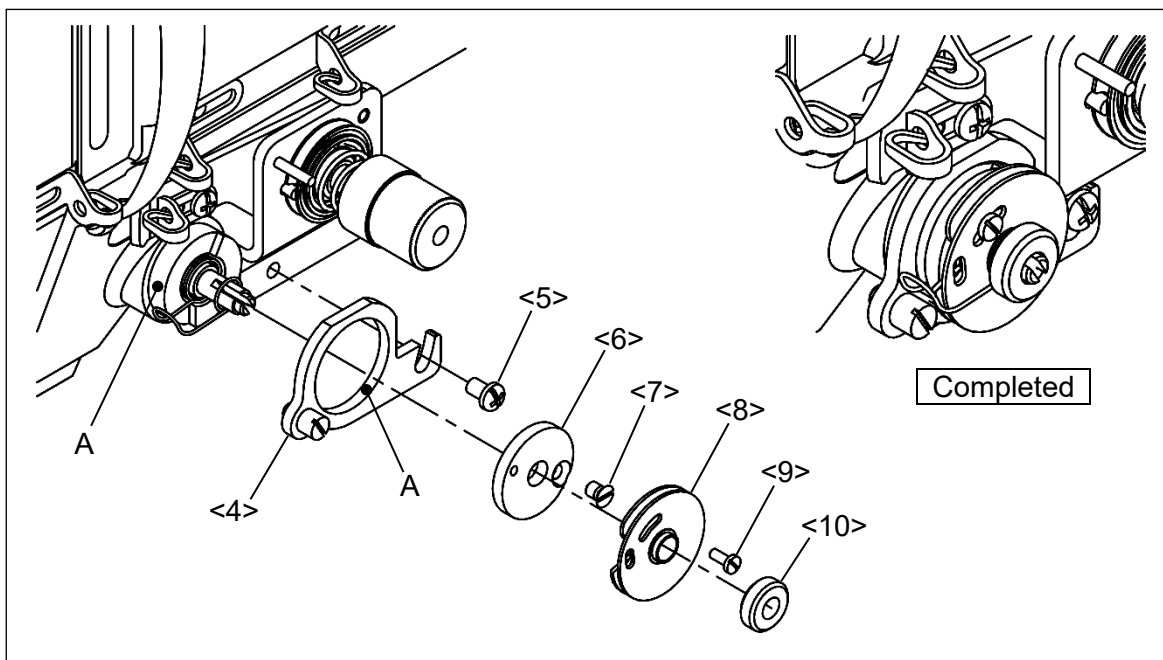

- <4>: Stopper <5>: Screw (SW-PW pan screw M4X8)
- <6>: Base plate <7>: Screw <8>: Thread guide <9>: Screw <10>: Thumb screw

3-6. Installation of the slide plate

- (1) Remove the needle plate <3> and two screws <4> from existing slide plate and install these parts to the new slide plate <1>. By the same way, install the knurled knob <5> to the slide plate <1> with screw <6>.
- (2) Install the slide plate <1> to the machine bed with four screws <2>.

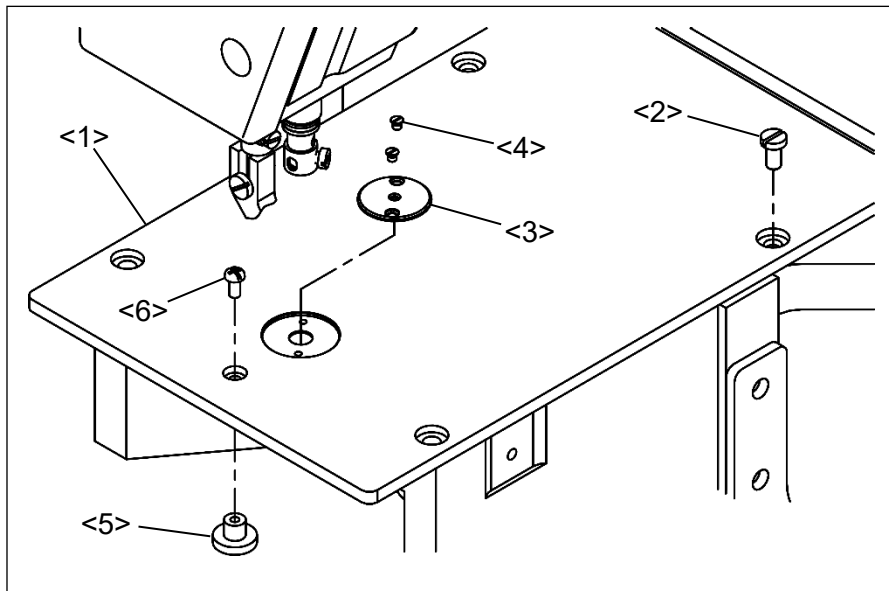

<1>: Slide plate <2>: Screw (Flat screw M4X8) <3>: Needle plate

<4>: Screw (Countersunk screw 3/32X2.8) <5>: Knurled knob <6>: Screw (Pan screw M3X6)

3-7. Installation of the support bracket

Notice The slide plate (large size) is not included in this device [MP-J25-PS package]. Please prepare it by customer or purchase optional slide plate [material: glass epoxy resin] by referencing parts list at the end of this manual. For details, please see slide plate dimensional drawing at the end of this manual.

- (1) Install the support bracket right <1> with each two of screws <7> and washer <8>. By the same way, install the support bracket left <2> to the opposite side of machine bed.
- (2) Install the adapter <4> with screw <5> and washer <6>. By the same way, install it to the opposite side.
- (3) Install the stiffening plate <3> with two screws <5> and washers <6>.

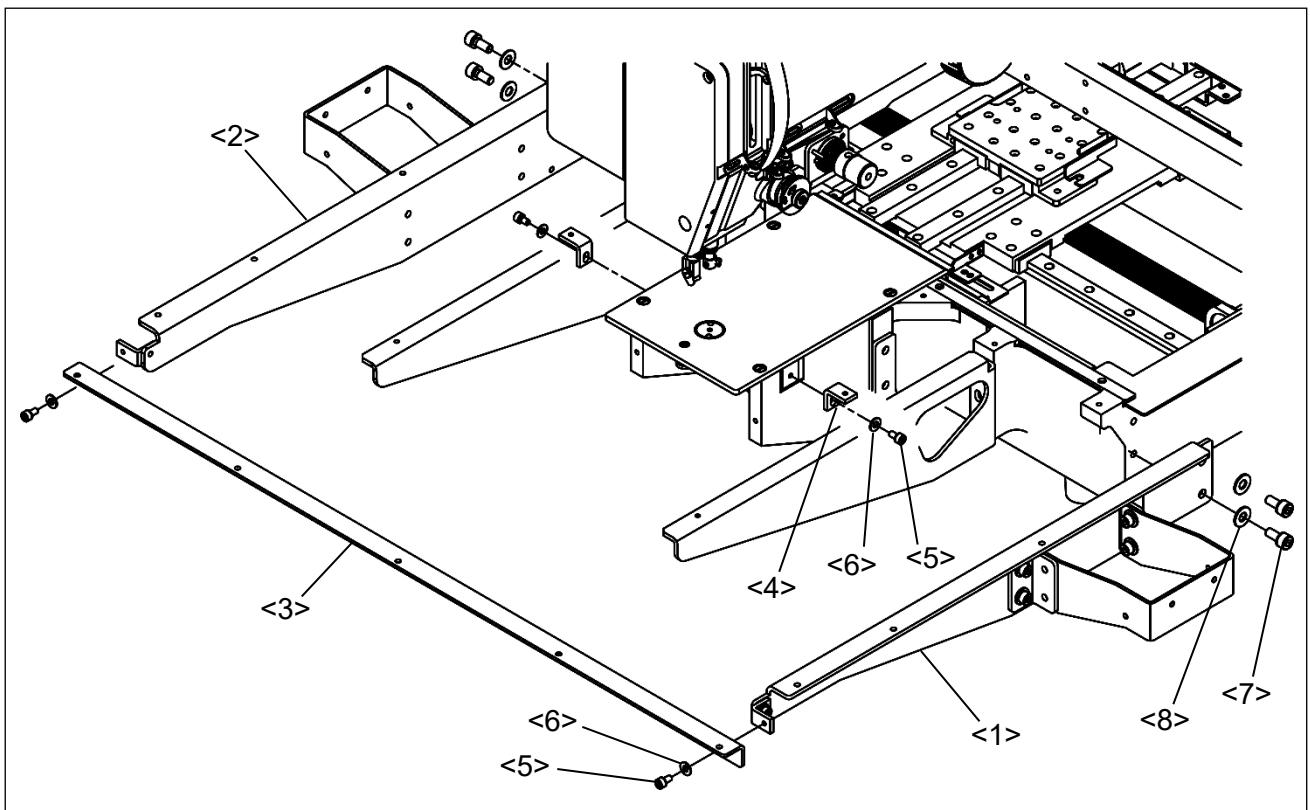

- <1>: Support bracket right <2>: Support bracket left <3>: Stiffening plate <4>: Adapter
<5>: Screw (Safety socket bolt M4X8) <6>: Washer (Large washer 4)
<7>: Screw (Safety socket bolt M6X12) <8>: Washer (Small washer 6)

3-8. Installation of the base bracket

When install the base bracket <1> it is necessary to install without any twisting or inclining against the X-Y table. To prevent the sewing defect and other abnormal machine behavior please install the base bracket <1> by referencing following procedures.

Note Make sure if the X-Y table moves smooth and uniformly when move the X-Y table by hand before starting the install operation. In this time, make sure if the X and Y timing belt tension is proper.

(1) Install the base bracket <1> to the shaft holder <2> and movable race Y <3> with each four of screws <5>, washers <6> and screws <7>.

(2) Make sure if the X-Y table moves smooth and uniformly when move the X-Y table by hand. If there are any discomfort moving described as below, it is necessary to loosen the screws <5>, <7> and adjust the base bracket <1> position.

* The X-Y table become heavy during moving by hand.

* X-Y table cannot move in each direction independently. For example, the movable race Y <3> moves slightly during the movable race X <4> moving by hand.

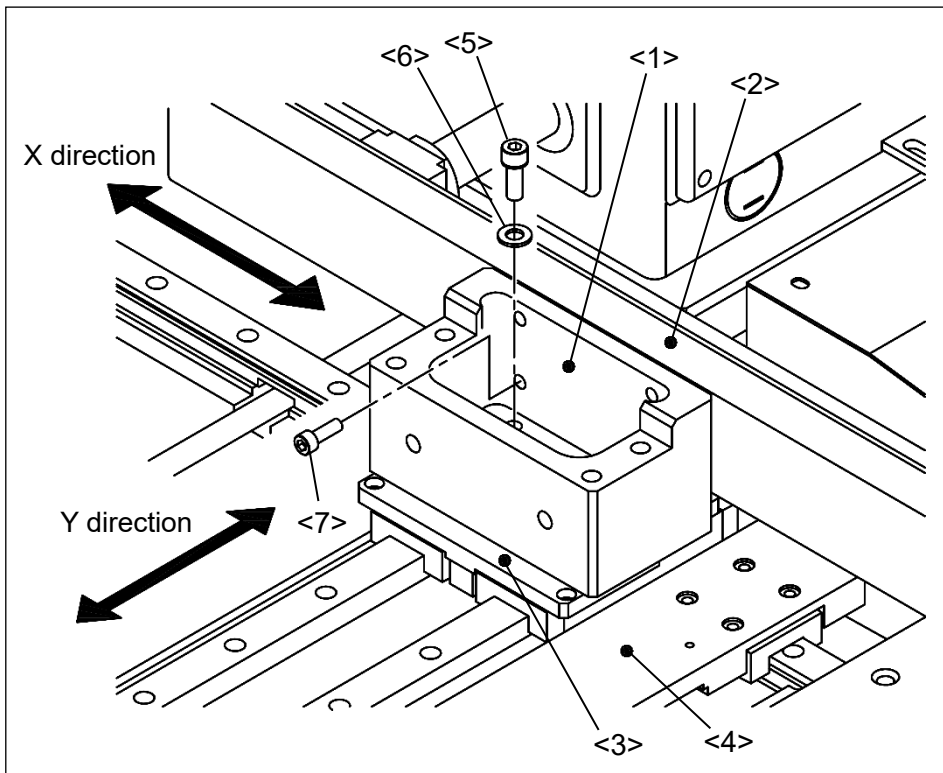

<1>: Base bracket <2>: Shaft holder <3>: Movable race Y <4>: Movable race X

<5>: Screw (Safety socket bolt M5X14) <6>: Washer (Small washer 5)

<7>: Screw (Socket bolt M4X12)

3-9. Installation of the perfect stitch unit (Installation of the motor drive unit)

(1) Install the motor base support <1> and spacer <2> to the bottom of machine arm with four screws <3>.

In this time, fix the four screws <3> temporary.

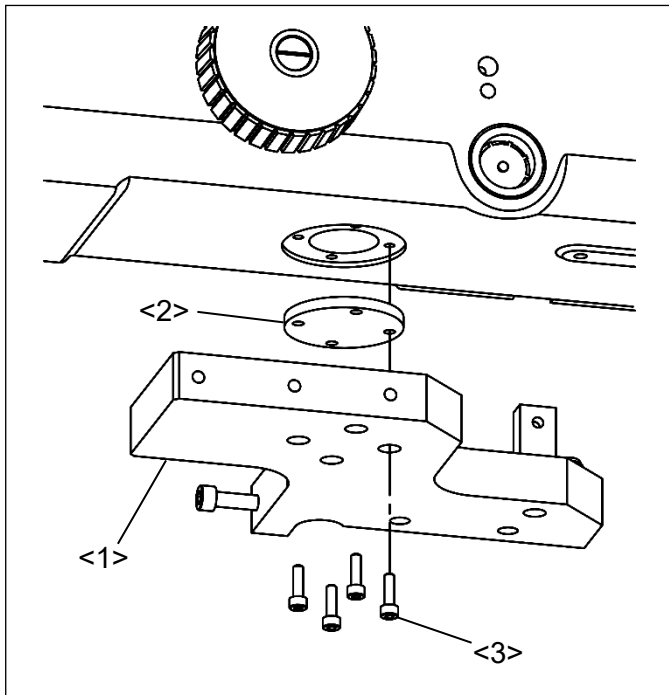

<1>: Motor base support

<2>: Spacer

<3>: Screw (Socket screw M4X20)

(2) Attach the block <4> to the machined groove which has left side of machine arm with screw <5>. When tightening the screw <5> tighten the screws <3> and screw <6> alternately.

(3) Check again each screws <3> and screw <5>, <6> tightened firmly.

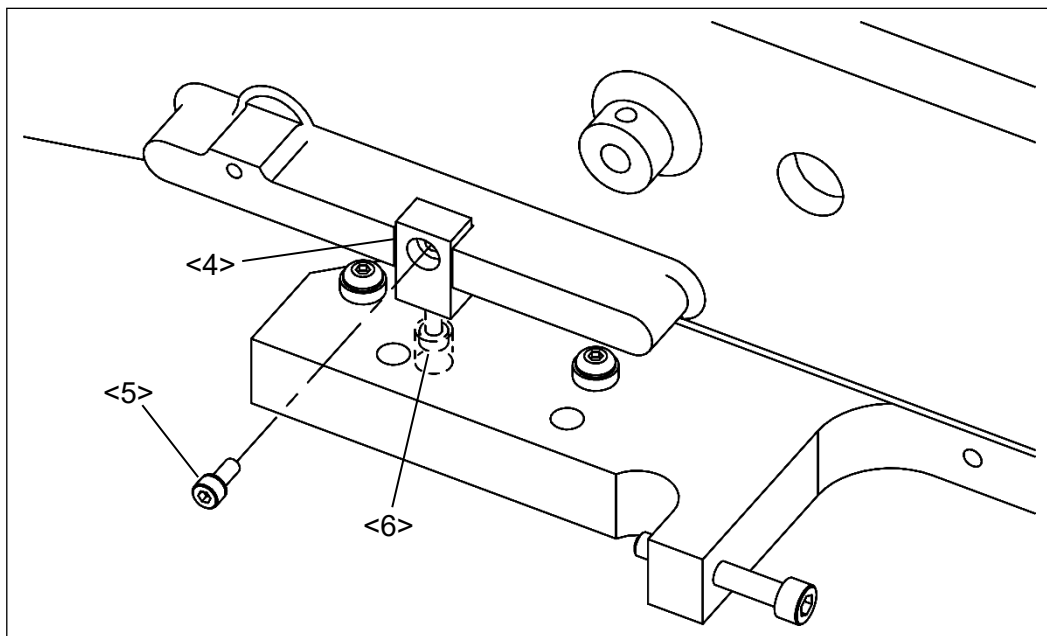

<4>: Block <5>: Screw (Safety socket bolt M4X12)

<6>: Screw (Socket bolt M4X16)

(4) Install the motor drive unit <7> to the motor base support <1> with each two of screws <8> and washers <9>. In this time, fix the screws <8> temporary because it is necessary to adjust the motor drive unit <7> position later. In the other hand, please note that the timing belt <10> is not to be bend until attach to the driven belt pulley.

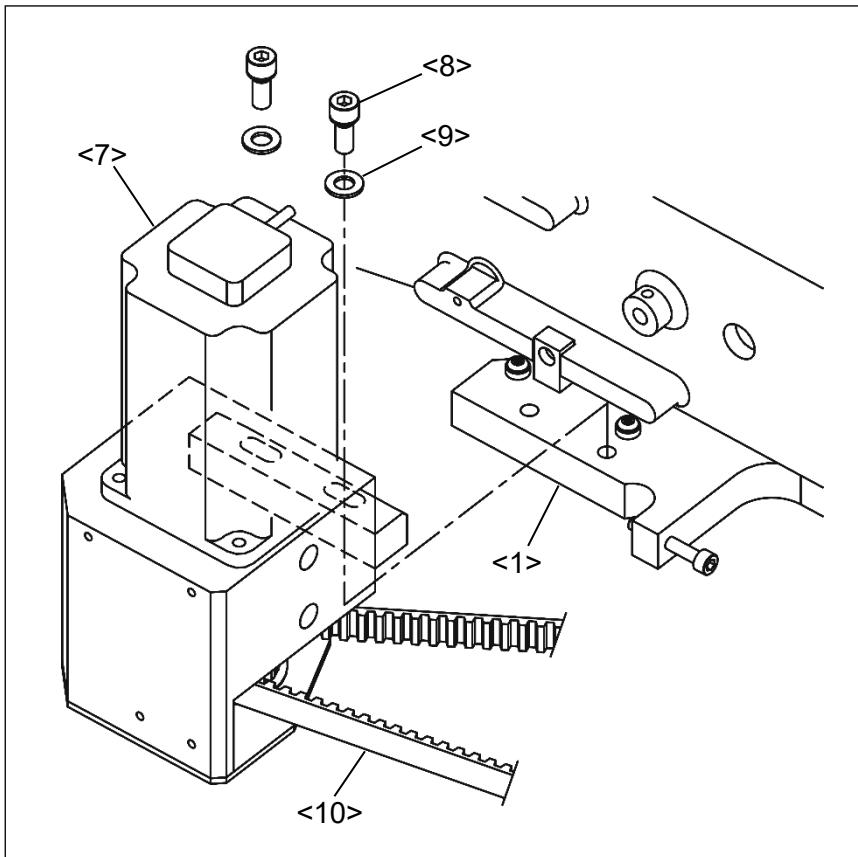

<1>: Motor base support

<7>: Motor drive unit

<8>: Screw (Socket bolt M8X40)

<9>: Washer (Large washer 8)

<10>: Timing belt

3-10. Installation of the perfect stitch unit (Installation of the clamp rotating unit)

(1) Attach the timing belt <3> to the clamp rotating unit <1> then, install it to the support bracket <2> and adapter <5> which has machine head with two of screws <4> and each three of screws <6>, washers <7>.

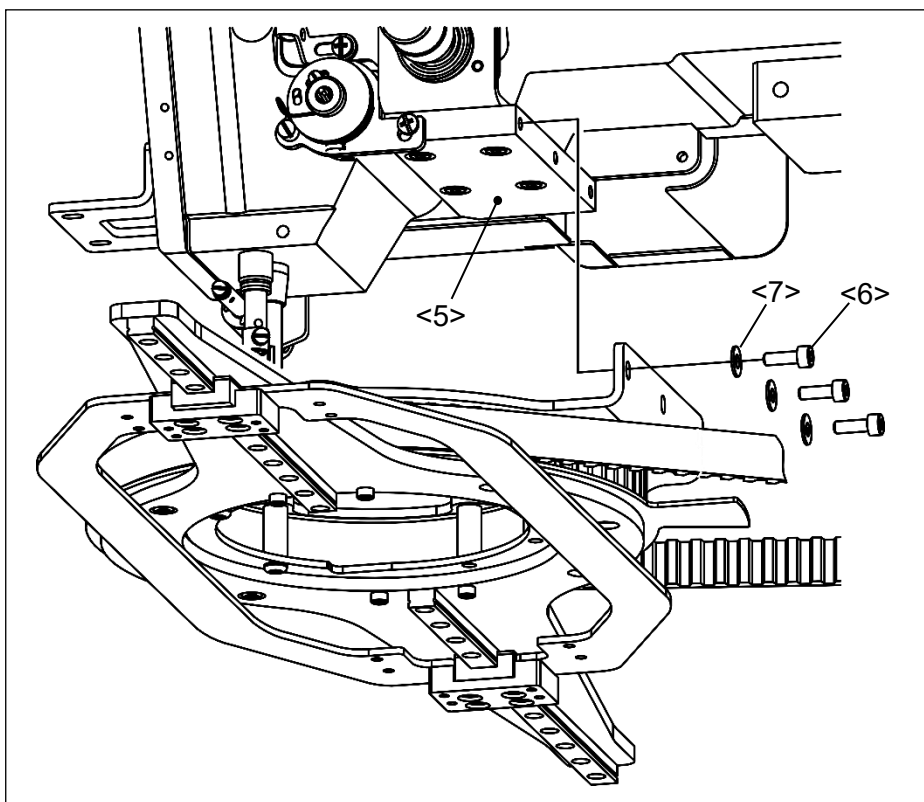
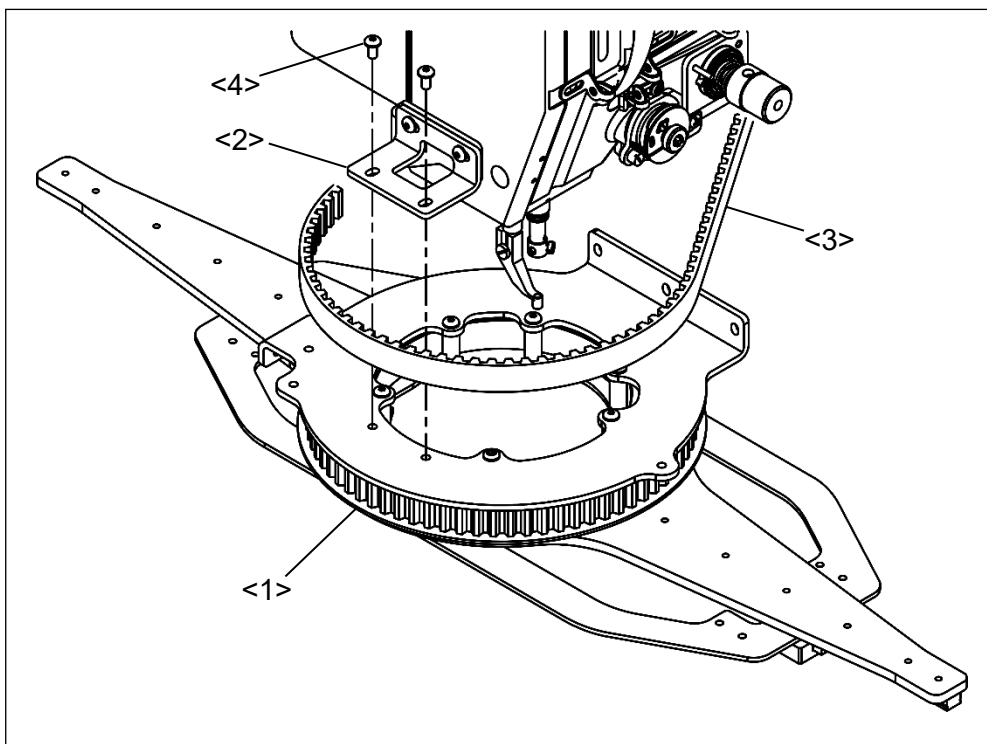

- <1>: Clamp rotating unit <2>: Support bracket <3>: Timing belt
<4>: Screw (Button bolt M4X6) <5>: Adapter <6>: Screw (Socket bolt M4X12)
<7>: Washer (Large washer 4)

(2) After install the clamp rotating unit, loosen the four screws <4>, two screws <8> a little so that the support bracket <2> position can be adjusted. In the other hand, loosen the three of screws <6> referencing previous paragraph (1).

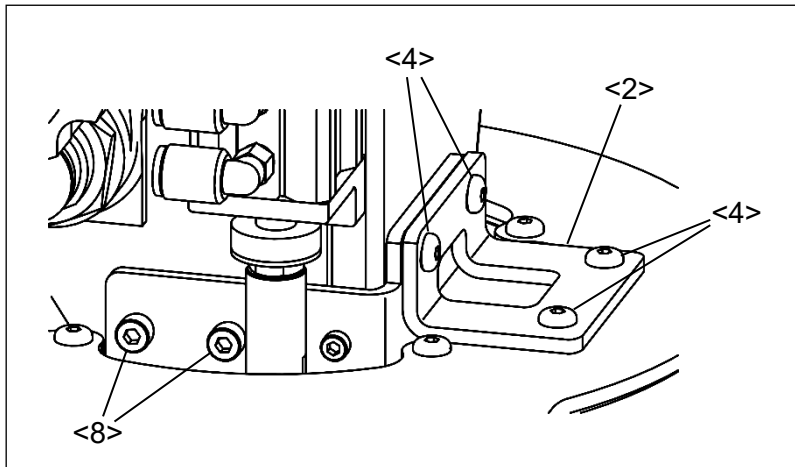

<2>: Support bracket
 <4>: Screw
 <8>: Screw

(3) Assemble the PS unit install jig <9> on the slide plate <12> with two of hexagonal post <10> and four of wing bolts <11>.

Note The PS unit install jig cannot apply directly to the slide plate in the assemble state because of parts interference. Please assemble directly on the slide plate and set to the clamp rotating unit.

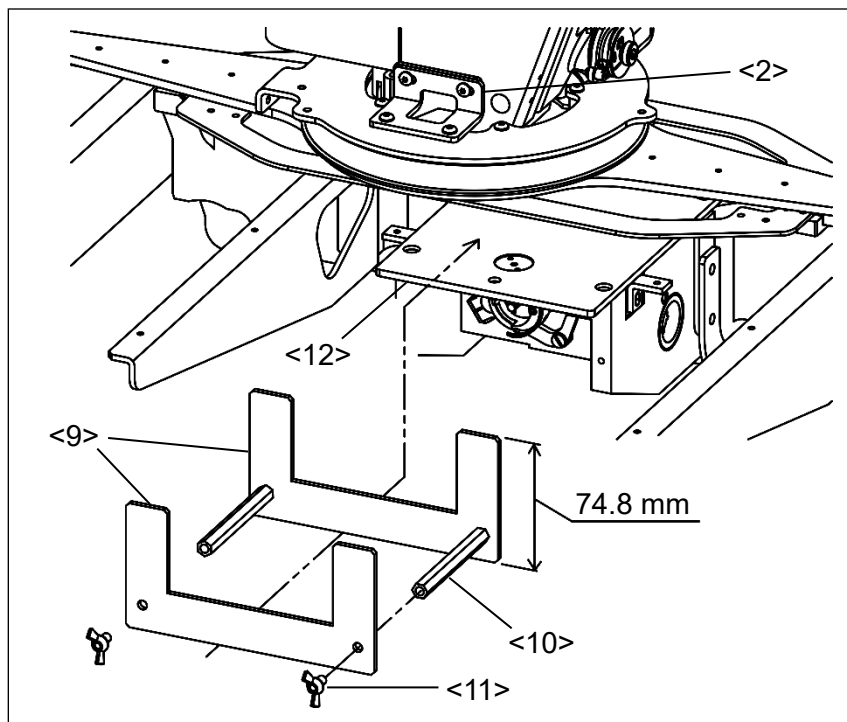

<2>: Support bracket
 <9>: PS unit install jig
 <10>: Hexagonal post
 <11>: Wing bolt
 <12>: Slide plate

(4) Set the PS unit install jig <9> to the bottom of the clamp rotating unit <1> which has hatched line in below figure. The clamp rotating unit <1> to be placed on the PS unit install jig <9>. In this time check if there is no gap with bottom of the clamp rotating unit <1> and PS unit install jig <9>. In the other hand, check if the PS unit install jig <9> is vertical to the slide plate with no gap.

Note The clamp rotating unit <1> is necessary to install parallel with slide plate and adjust the bottom of the clamp rotating unit position to be 74.8 mm from top of the slide plate. For the steady and smooth installing please use PS unit install jig which included in this devices package.

(5) Tighten the three screws <6> by referencing previous paragraph (1) and four screws <4>, two screws <8> by referencing previous paragraph (2), the clamp rotating unit <1> fixed.

(6) To confirm if the clamp rotating unit <1> is parallel with slide plate, rotate the clamp rotating unit <1> in the any direction and check the install condition same as previous paragraph <4>. If necessary loosen the screws and readjust the installing position.

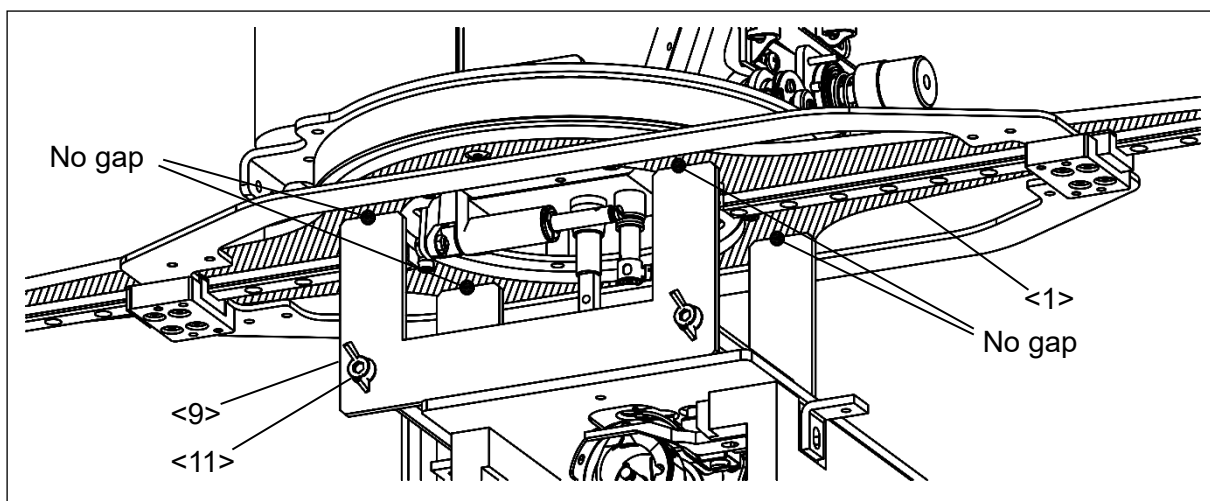

<1>: Clamp rotating unit <9>: PS unit install jig <11>: Wing bolt

(7) After install the clamp rotating unit <1>, take the PS unit install jig <9> apart by removing the wing bolts <11> on the slide plate and remove from the sewing machine.

3-11. Adjustment of the timing belt tension

(1) Check if two screws <2> which fixing the motor drive unit <1> are loosened.

(2) loosen the nut <5> and adjust the timing belt tension by turning the tension screw <4> in the arrow direction. Adjust the timing belt tension in the range of 220 ± 30 (N)

Note In the case of rotation position, the timing belt tension may fluctuate depending on mounting state of this device. Therefore, measuring plural position of timing belt tension after rotating the timing belt and adjust it by average value. Above explanation is based on using by sonic type tension meter.

(3) After adjustment, tighten the screw <2> and nut <5>.

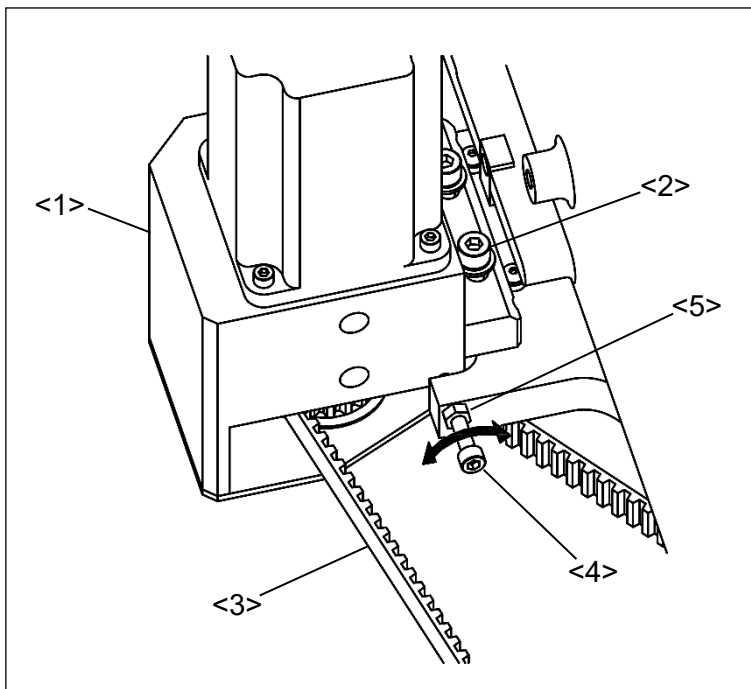

- <1>: Motor drive unit
- <2>: Screw
- <3>: Timing belt
- <4>: Tension screw
- <5>: Nut

Note When using the sonic type tension meter set each parameter according to following value.

Belt width: 15 (mm)

Belt span: 334 (mm)

Mass of per unit width for one meter in length: 5.4 (g/mm/m)

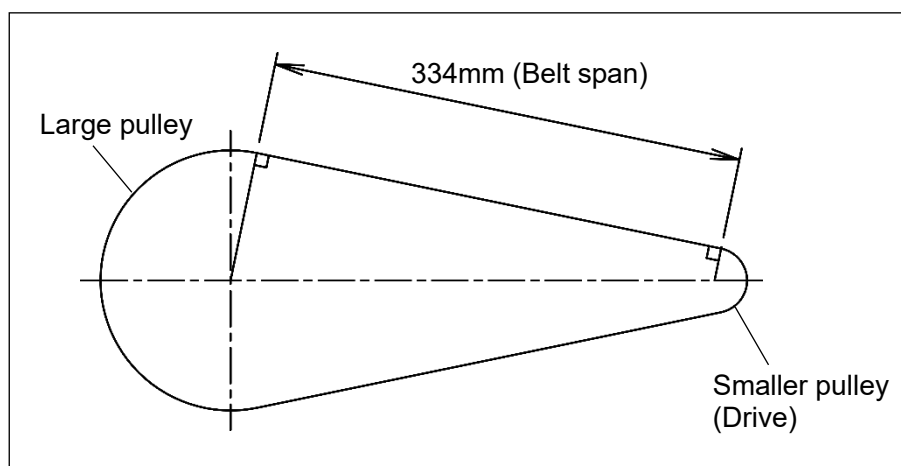

3-12. Installation of the turn table unit

(1) Install the frame section of the turn table unit <1> to the base bracket <2> with each four screws <3> and washers <4>.

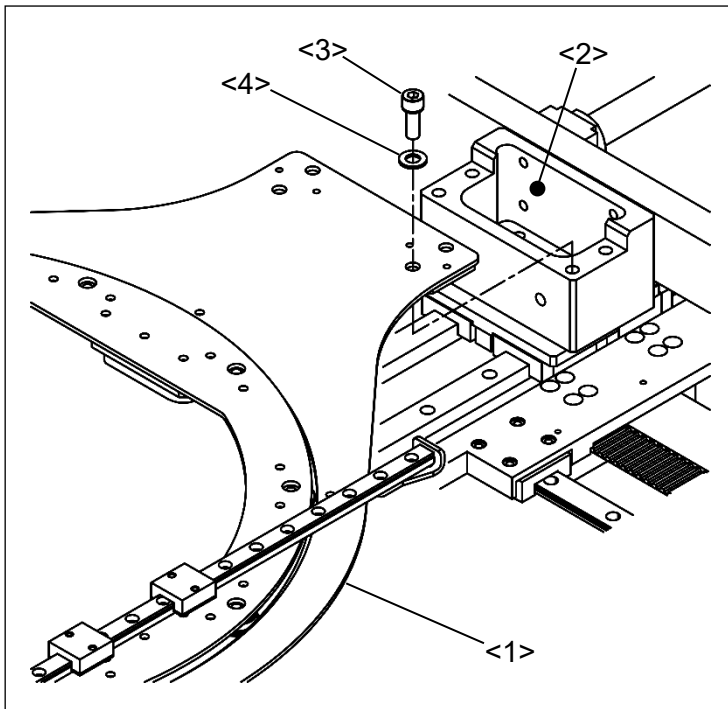

- <1>: Turn table unit
- <2>: Base bracket
- <3>: Screw (Socket bolt M6X16)
- <4>: Washer (Small washer 6)

(2) Install the slide rail section of turn table unit <1> to the clamp rotating unit <5> with four screws <6>.

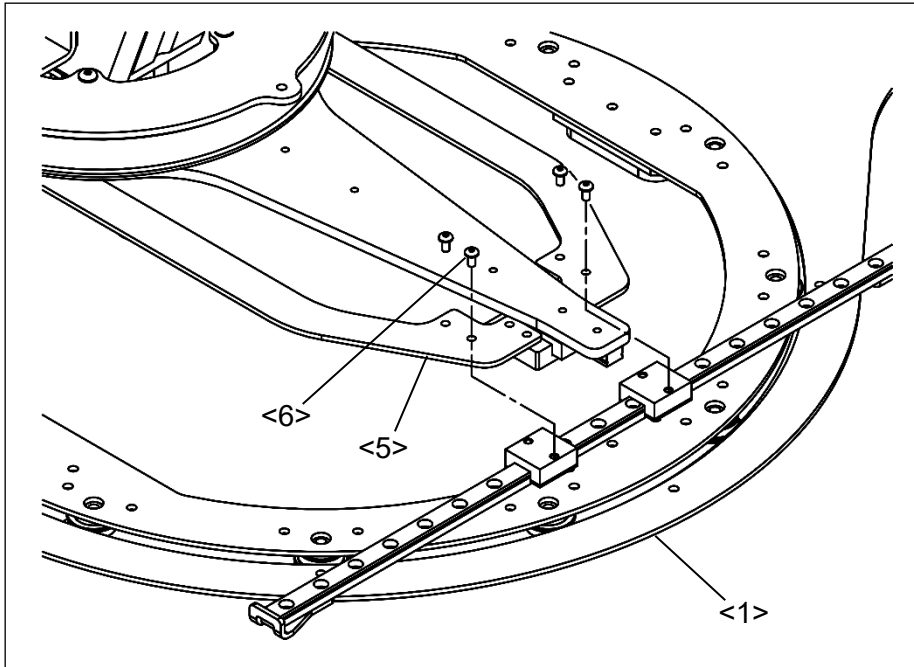

- <1>: Turn table unit
- <5>: Clamp rotating unit
- <6>: Screw (Button bolt M3X5)

(3) By the same way, install the opposite side referencing by before paragraph (2).

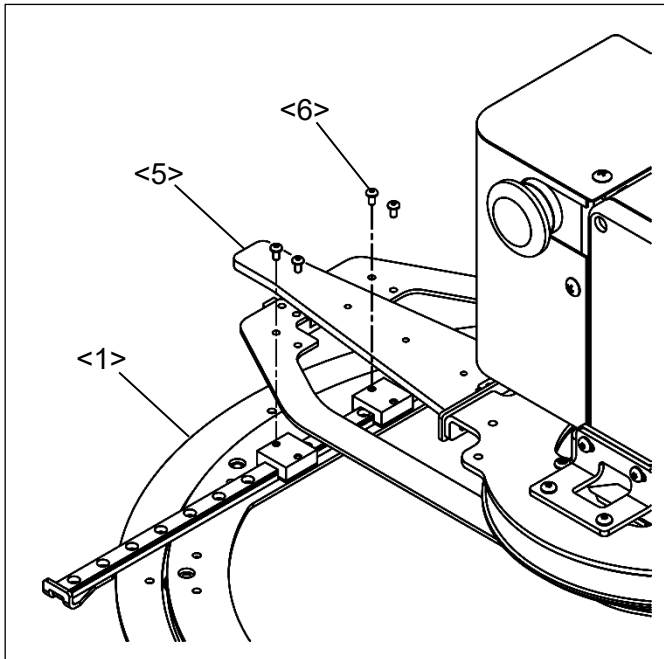

- <1>: Turn table unit
- <5>: Clamp rotating unit
- <6>: Screw (Button bolt M3X5)

3-13. Installation of the θ axis sensor unit

(1) Install the θ axis sensor unit <1> to the clamp rotating unit with each two screws <2> and washers <3>.

In this time, confirm the gap between θ axis sensor and sensor plate <4> is in the range of 1 to 1.5 mm.

(2) According to bellow figure, wiring the θ axis sensor cable to the MIF board which has back of machine bed along the machine arm left side. In this time, fix the sensor cable with cable holder <5> and screw <6>.

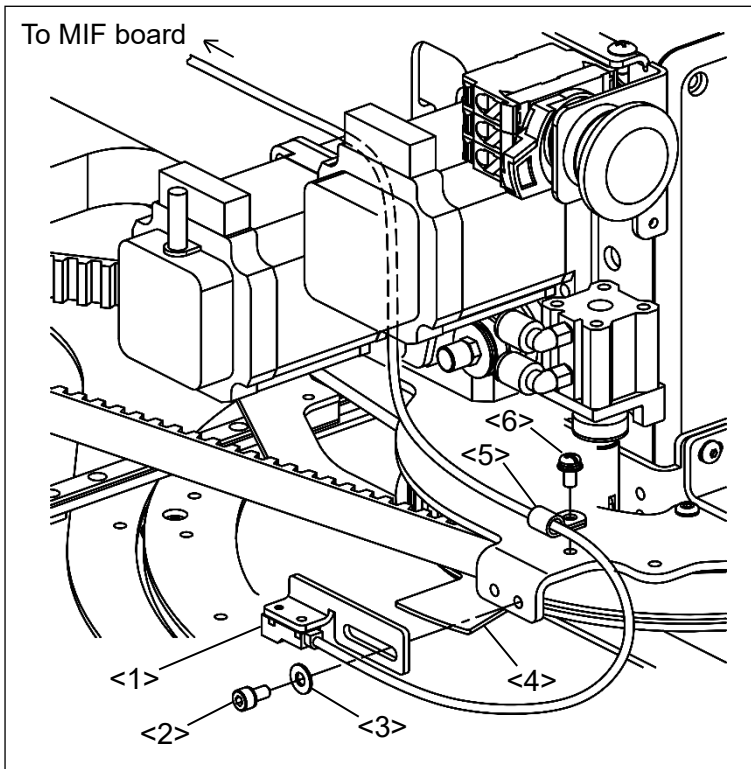

- <1>: θ axis sensor unit
- <2>: Screw (Safety socket bolt M4X8)
- <3>: Washer (Large washer 4)
- <4>: Sensor plate
- <5>: Cable holder
- <6>: Screw (SW-PW pan screw M4X6)

3-14. Connection of the electric cables

According to following procedures wiring the [θ axis and digital tension axis motor cable <1>] and [θ axis and digital tension axis encoder cable <2>] which included in this devices package.

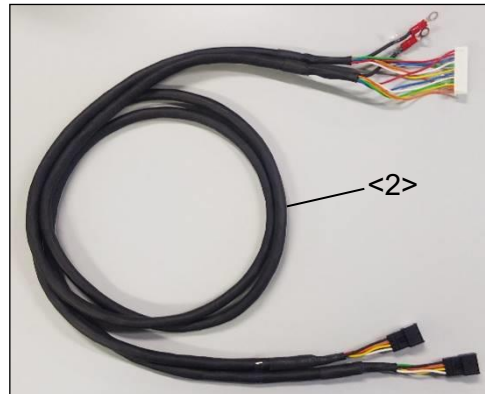
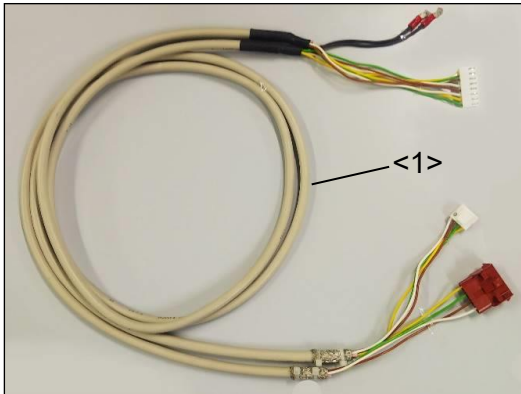

<1> θ axis and digital tension axis motor cable

<2> θ axis and digital tension axis encoder cable

(1) Remove the existing digital tension motor cable and existing digital tension encoder cable completely by removing the connector which connecting digital tension axis motor <3> and MIF board.

(2) Connect the [θ axis and digital tension axis motor cable <1>] and [θ axis and digital tension axis encoder cable <2>] to the digital tension axis motor <3> according to following figure.

Note When connect the encoder cable match the “D” marking indicated on connector.

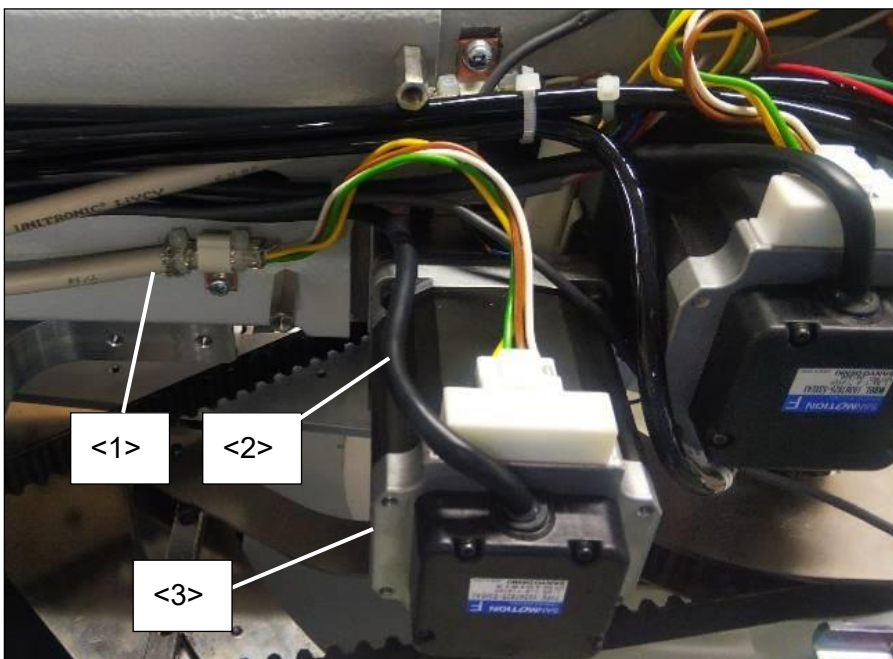

<1>: θ axis and digital tension axis motor cable

<2>: θ axis and digital tension axis encoder cable

<3>: Digital tension axis motor

(3) Connect the [θ axis and digital tension axis motor cable <1>] and [θ axis and digital tension axis encoder cable <2>] to the θ axis motor <4> by referencing following figure.

Note When connect the encoder cable match the “T” marking indicated on connector.

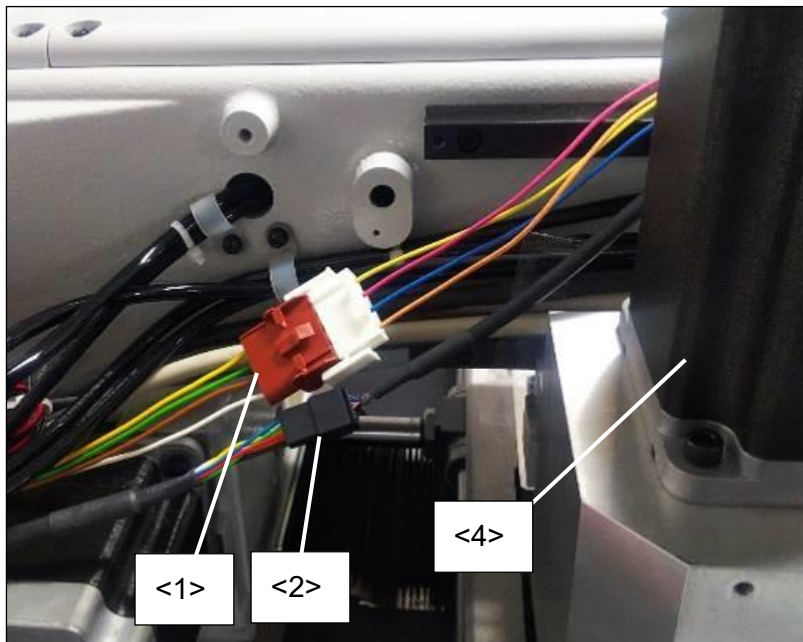

- <1>: θ axis and digital tension axis motor cable
- <2>: θ axis and digital tension axis encoder cable
- <4>: θ axis motor

- (4) Connect the [θ axis and digital tension axis motor cable <1>] to the CON 15 and connect the [θ axis and digital tension axis encoder cable <2>] to the CON 14 by referencing following figure. Attach the each cables ground terminal to the MIF board panel with screw <3>.
- (5) Connect the θ axis sensor cable to the CON 7.

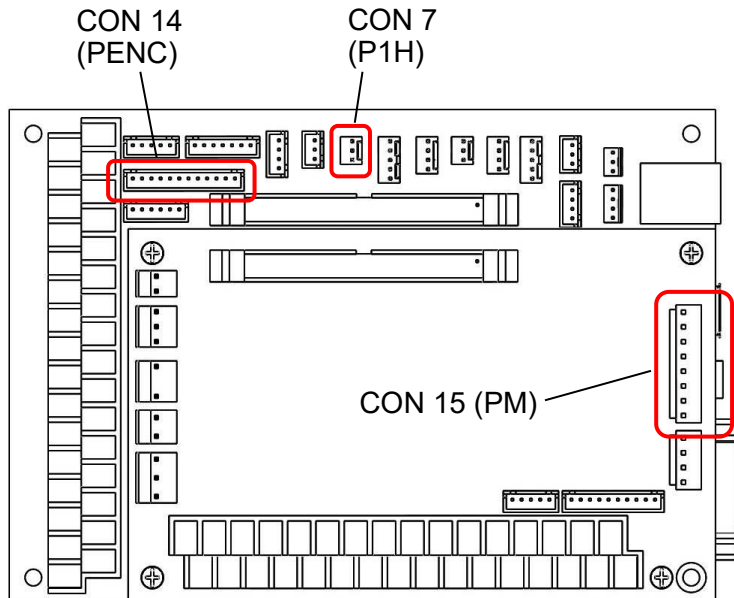

Arrangement drawing of MIF board connector

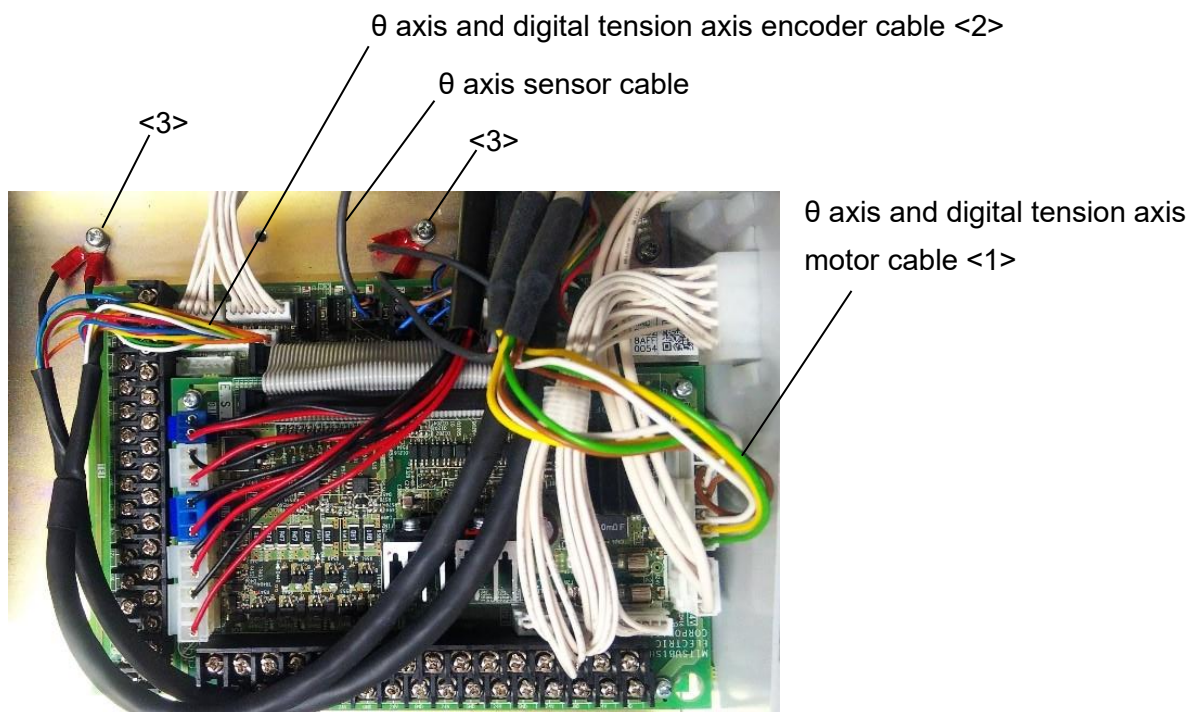

Photograph of MIF board wiring

3-15. Installation of the θ axis motor cover

(1) Attach the θ axis motor cover <1> to the motor drive unit with three screws <2>.

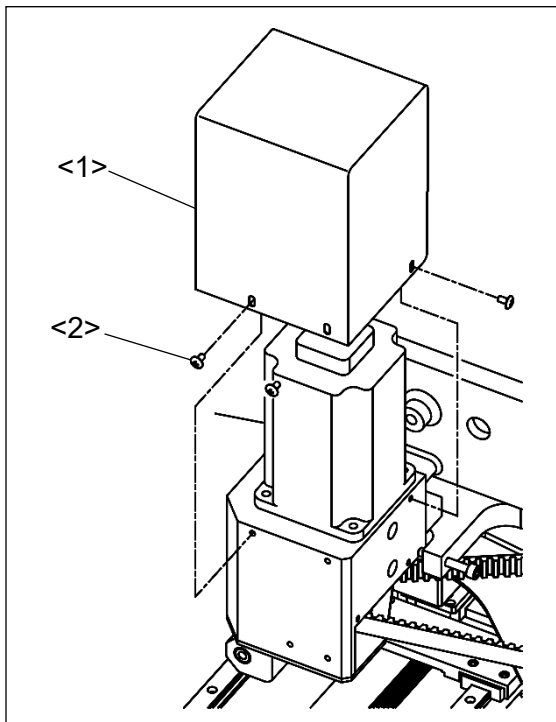

<1>: θ axis motor cover

<2>: Screw (Truss screw M4X8)

3-16. Installation of the XY cover

- (1) Install the X cover plate (right) <1>, X movable plate (right) <2> and spacer <3> to the machine bed with three screws <4>. In this time, it is necessary to use X cover plate (right) <1> and screws <4> which included with this devices package. X movable plate (right) <2> and spacer <3> are to be used same parts that removed in the paragraph [3-1].
- (2) By the same procedures install the X cover plate (left), X movable plate (left) and spacer to the opposite side of machine bed.

Note To prevent the clamp and machine breakage it is necessary to use exclusive parts which are X cover plate and screw (countersunk screw) included with this device.

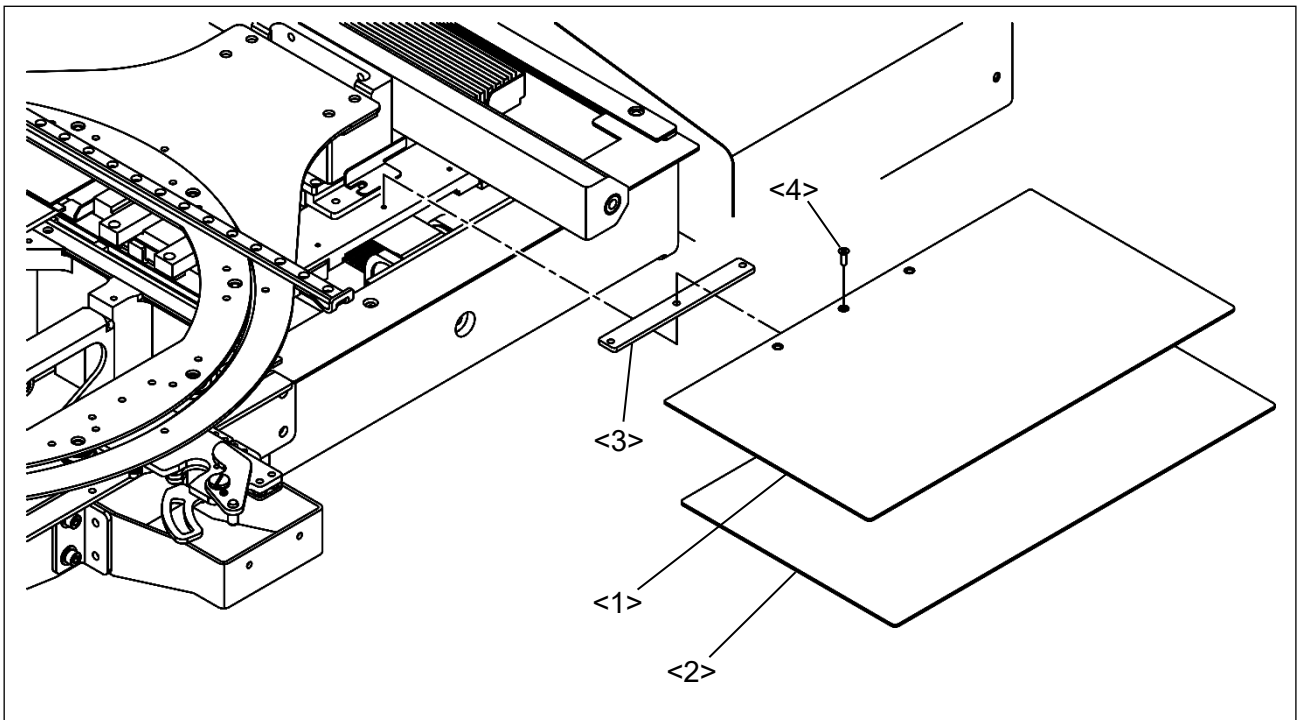

<1>: X cover plate (right) <2>: X movable plate (right) <3>: Spacer
<4>: Screws (Countersunk screw M3x12)

3-17. Installation of the various cover

- (1) By referencing the paragraph [3-2. Removing the various cover] attach the various cover to the machine.

4. INITIAL SETTING

4-1. Installation of the system

- (1) When operate the perfect stitch unit, it is necessary to install the system file. The system file is included with this device.
- (2) Refer to the instructions in the paragraph [6 Set up] in the PLK-J-CU-20S CONTROL UNIT technical manual, install the system file.
- (3) After the installation is completed, select the model data [JP2516RY].

4-2. How to operate jig clamp

- (1) Push the jig <1> in the arrow direction and contact with clamp lever <2>.
- (2) Furthermore, insert the jig toward the U-shaped groove <3>. In this position, the jig <1> is locked.
- (3) At the same time, set the opposite side jig.
- (4) Check if the jig locked perfectly by moving the jig <1> or the work clamp.

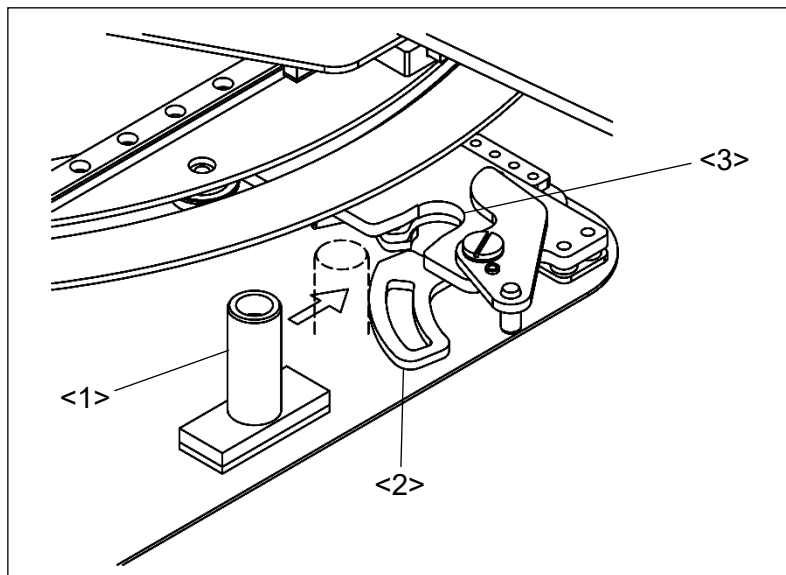

- <1>: Jig
- <2>: Clamp lever
- <3>: U-shaped groove

- (5) When remove the jig <1>, push the clamp lever <2> in the arrow direction. The jig <1> is ejected automatically by the jig ejector <4>.

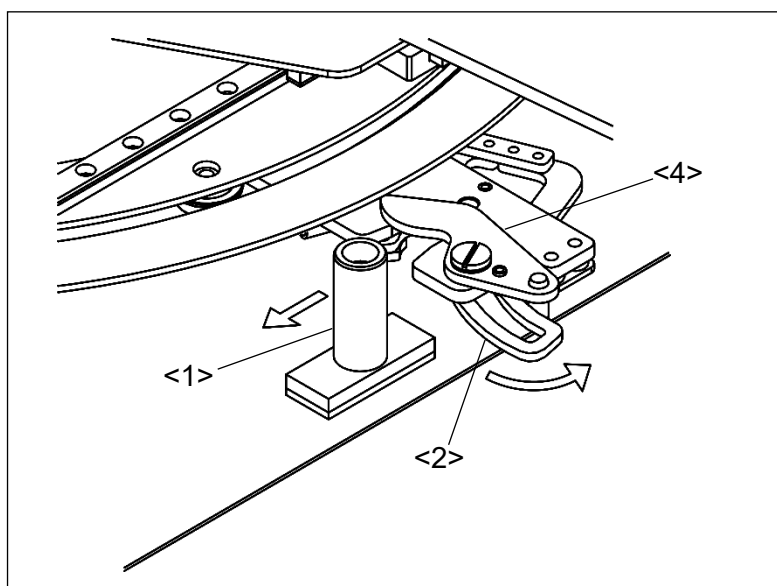

- <1>: Jig
- <2>: Clamp lever
- <4>: Jig ejector

4-3. Initial adjustment of turn table home position

At the first origin movement when turn the machine power on, turn table <1> moves toward home position. In this home position, turn table center is exactly aligning with needle center. According to following procedures, adjust the turn table <1> home position.

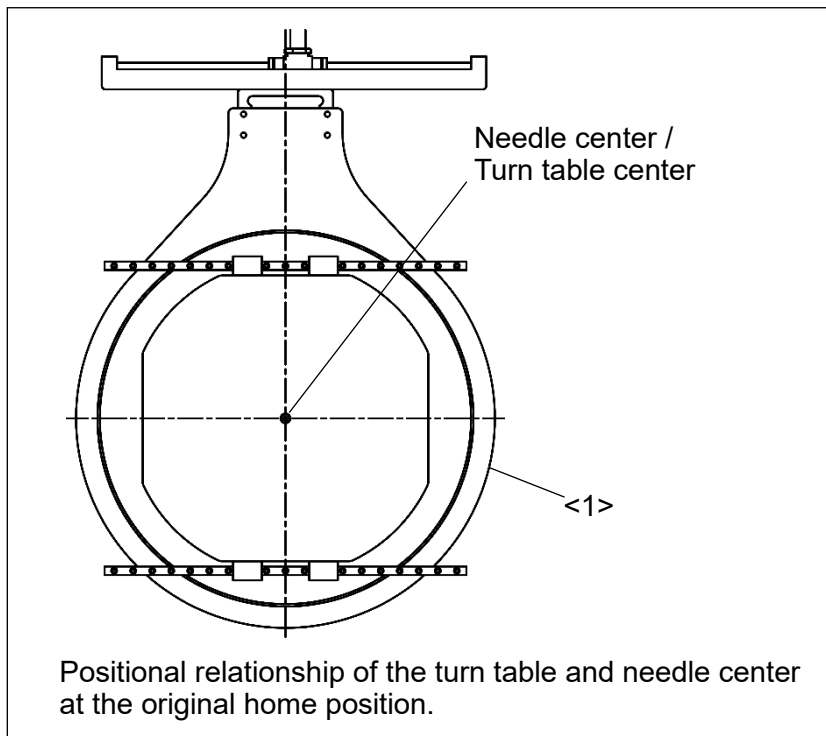

<1>: Turn table



(1) Turn the power switch on and press the home position return icon .

(2) After finishing the original movement attach the work clamp <2> which has fresh pieces of paper <3> on its surface to the jig clamp unit <4>.

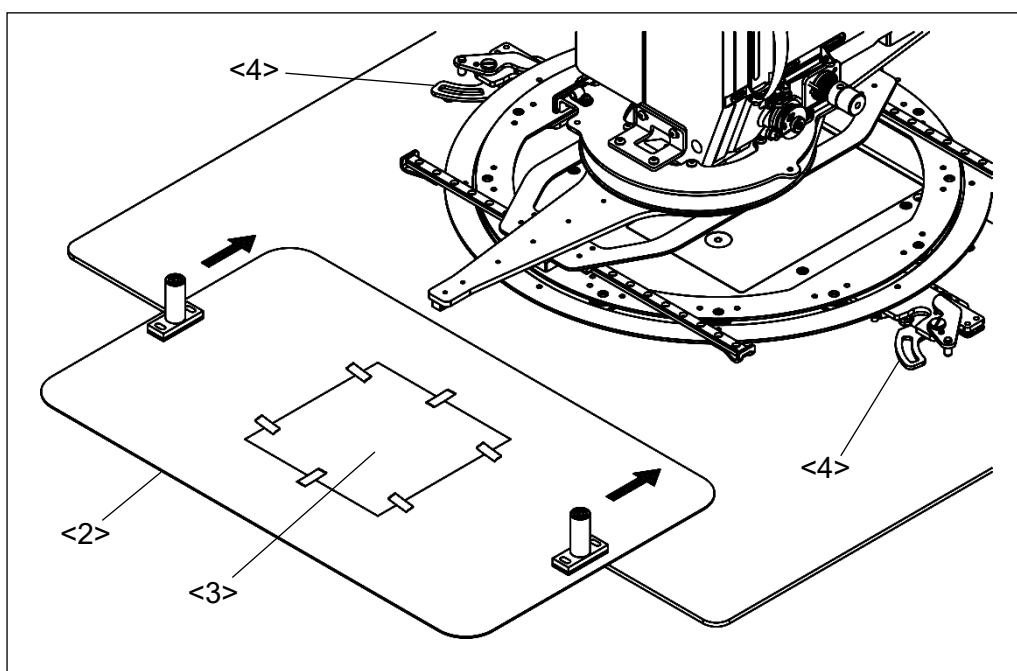
Note Please prepare the work clamp <2> and paper <3> by customer.





<2>: Work clamp <3>: Paper <4>: Jig clamp unit

(3) Press the  >  >  > from standard screen.

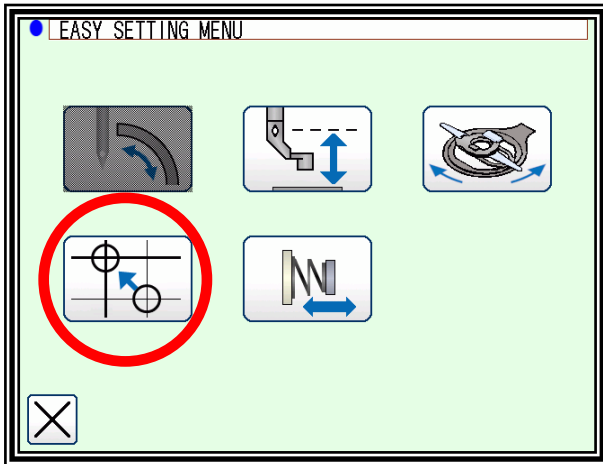
(4) Press the  icon from the easy setting menu.



(5) Press the  and  icon from the XY position adjustment screen. The hand pulley and the rotating arm can be move freely by hand.

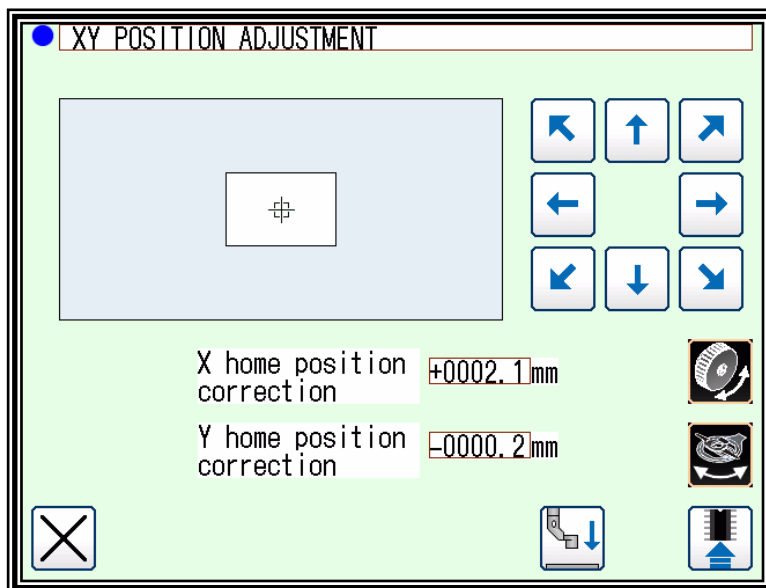

(6) By turning the hand pulley <7> stick the needle <5> tip and make a small pin hole <6> on the paper.

Note For make a small pin hole, not to stick through the needle and use fine needle.

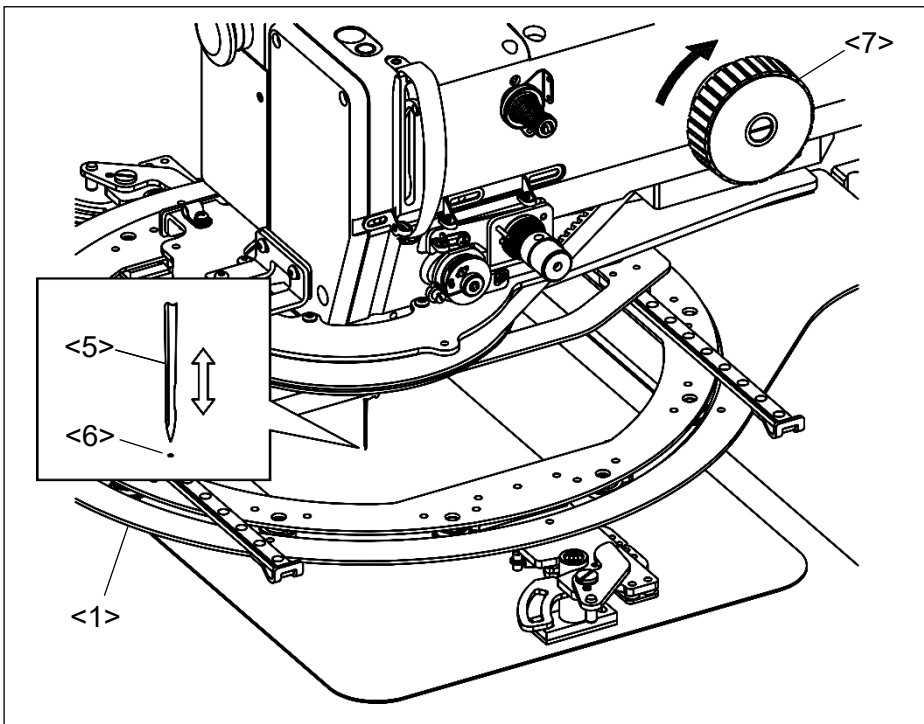

<1>: Turn table
<5>: Needle
<6>: Hole
<7>: Hand pulley

(7) Turn the hand pulley <7> and return the needle <5> to upper position.

(8) By moving the rotating arm <8> by hand and rotate the turn table <1> about 180 degree in clockwise or counter clockwise direction. It is not necessary to rotate 180 degree exactly.

Note To avoid machine error please rotate the θ table slowly.

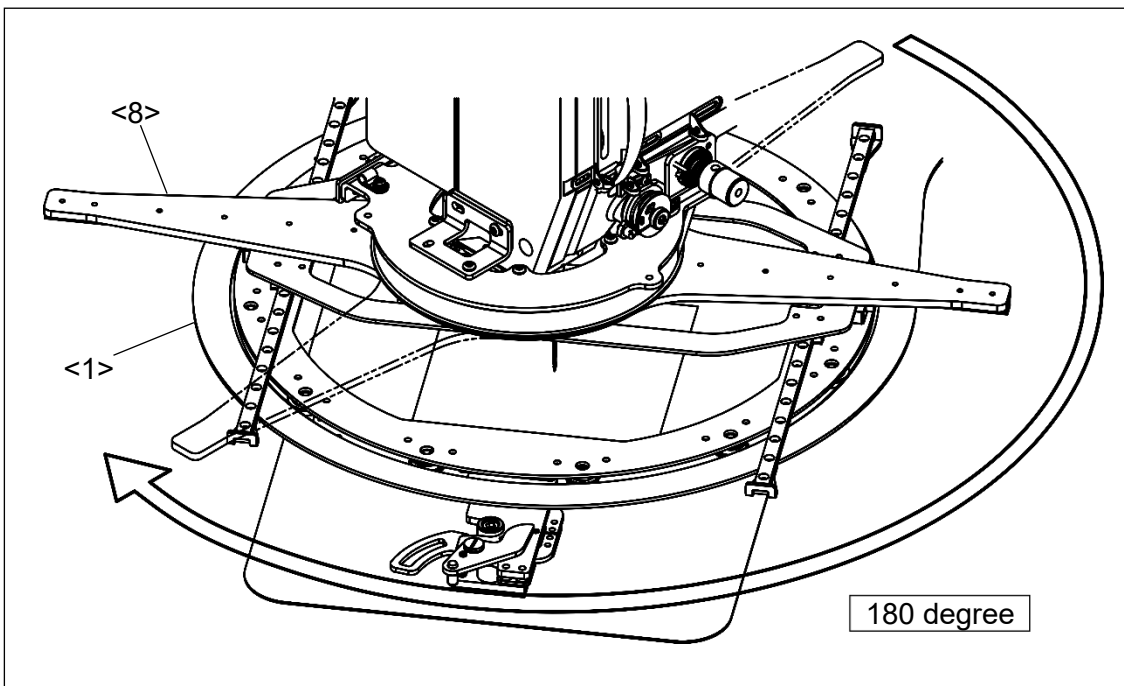

<1>: Turn table <8>: Rotating arm

- (9) After rotating the turn table stick the needle tip and make a small pin hole on the paper by the same procedure as previous paragraph (6).
- (10) Rotate the turn table about 180 degree again and back to the previous state that first pin hole position. It is not necessary to rotate 180 degree exactly.
- (11) Confirm each pin hole position, after remove the work clamp from jig clamp unit.
- (12) If each hole looks almost single hole, the turn table home position is correct. In this case, it is not necessary continue adjusting. Put the power switch off and finish adjustment.
- (13) If different check the distance among first and second hole. If this distance is wider, home position is widely displaced. In this case, it assumed that the correct home position (center of the turn table) exists middle of two holes.

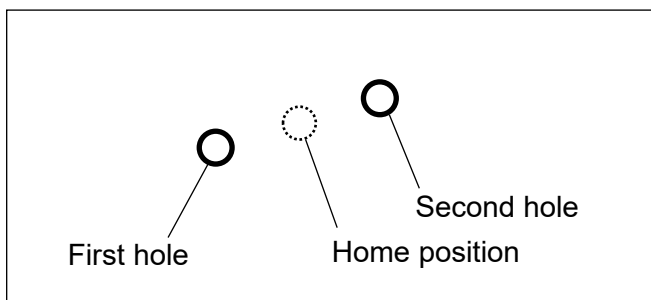

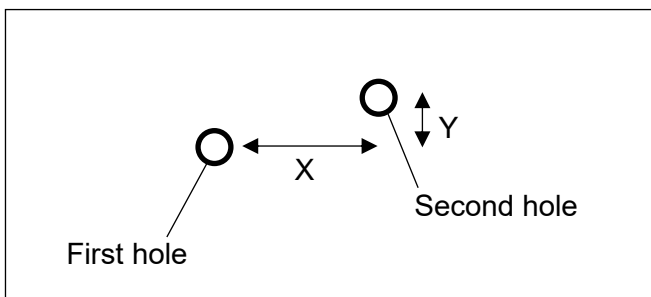

- (14) The turn table home position can be adjusted by each X-Y axis sensor position. At first, check the distance of each X-Y direction of second hole position against the first hole. According to this distance, adjust amount of X-Y axis sensor is determined.

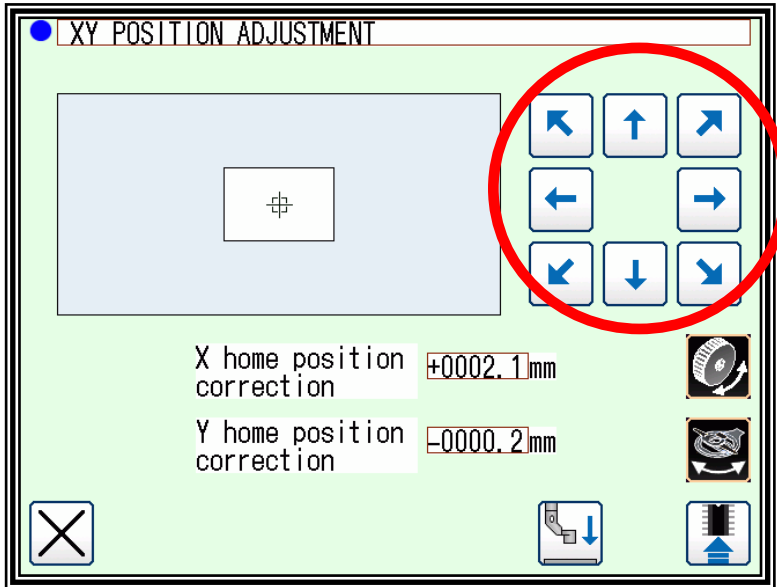

(15) From the X-Y position adjustment screen press any arrow icon and correct the X-Y sensor position. For example, above X direction hole distance is about 1 mm, move the X home position about 0.5 mm because the correct home position is the middle between two holes. Same procedures correct the Y home position.

Note For smooth adjusting operation, after correcting the home position check if the needle located middle of each holes by turning the hand pulley so that the paper nearby the needle.



(16) After the completion of setting, press the  icon and then press the home position return icon  from standard screen.

(17) Check the home position by same procedures above (2) to (11).

(18) Continue the correcting operation until two holes has no difference. During the correcting operation these holes difference getting wider it supposed that input different correcting value or input the different direction (+ or - direction).

Note When X-Y sensor position has changed from factory default setting, it is necessary to move back to around area center in advance.

(19) If the sewing result is different comparing input pattern, please readjust the turn table home position by referencing previous paragraph (15). However, it may have of no improvement because of sewing condition (work clamp, sewing pattern, sewing speed etc.,).

NOTICE1 This adjustment is important for sewing accuracy. Please adjust carefully as much as possible.

NOTICE2 It is necessary to readjust the turn table home position when remove the turn table unit. When the shock is applied to the turn table unit, it is same.

NOTICE3 It is impossible to change the X-Y table home position somewhere other than center of the turn table unit because of characteristic of this device.

4-4. Initial adjustment of rotation home position

The rotation home position of the turn table is necessary that the slide rail <1> is generally parallel with X direction. Install the work clamp in advance and start the adjusting operation.

Note The rotation home position of the turn table is based on the customers work clamp. Please refer to the previous paragraph [2-2. Positional relations of the machine and sewing area and clamp.] about the work clamp specification.

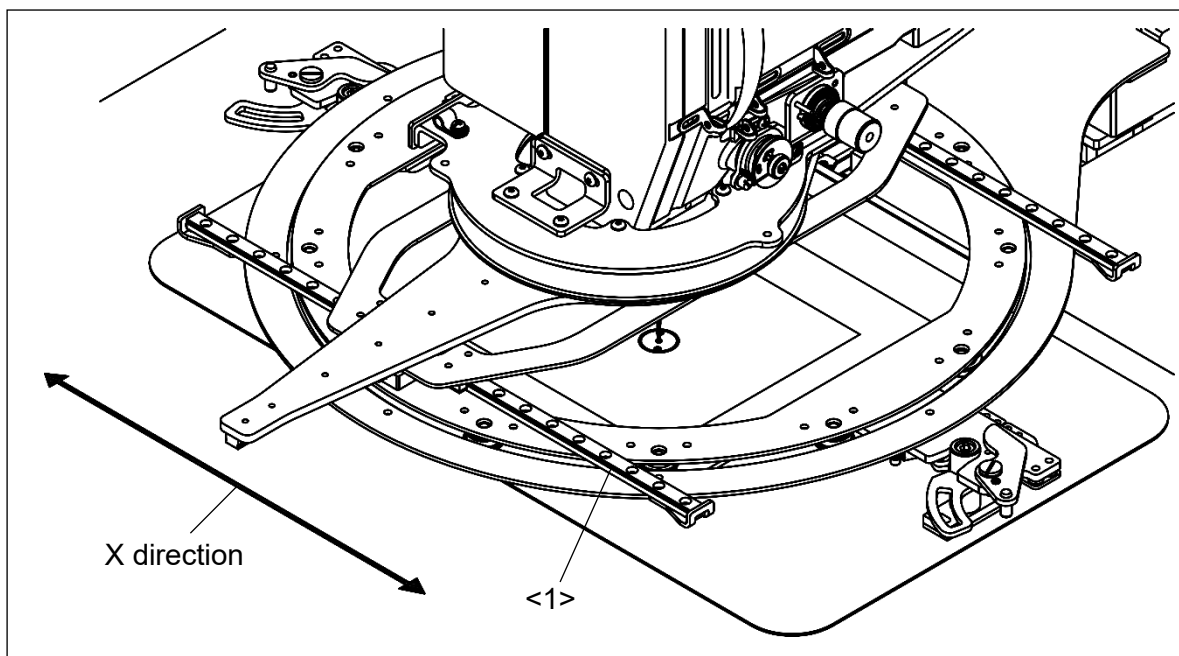

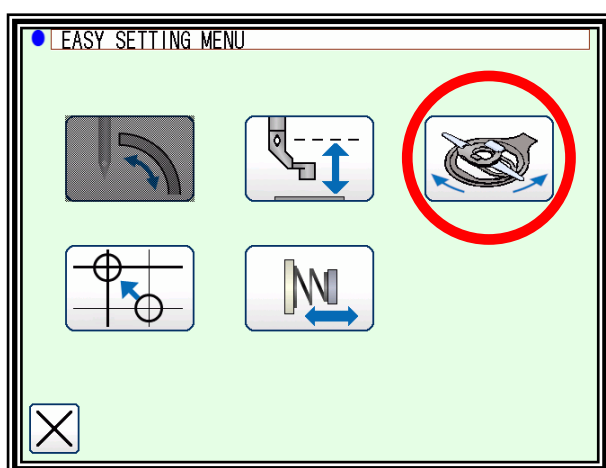

<1>: Slide rail

(1) Press the  icon from the easy setting menu.

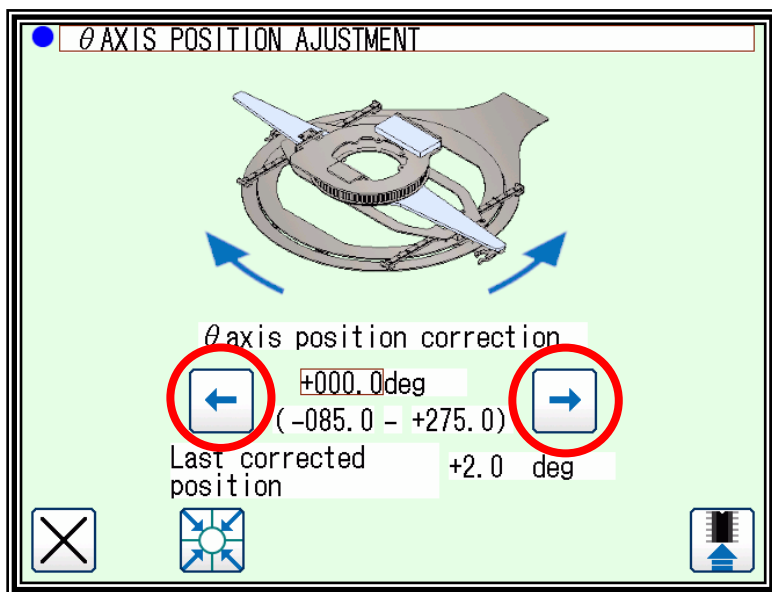

(2) From the θ axis position adjustment screen press any arrow icon and correct the θ axis position.



(3) After the completion of setting, press the  icon and then press the home position return icon  .

(4) Confirm if complete the adjustment by using jogging function. If sewing pattern is deviated with work clamp, it may have some interference with pressor foot or the needle. In this case, please readjust the above adjustment according to the previous paragraph (1) to (2).

5. PROPER OPERATION (CLAMP ROTATION)

5-1. Outline

With the sewing machine of the clamp rotation model, the clamp rotates, and the sewing machine sews in the direction corresponding to the setting by user.

Note

This function does not warranty perfect sewing quality.

Before using this function, carefully read this technical manual and other technical manual, and set not only the sewing direction but also the sewing machine that is most suitable for each sewing product.

5-2. Basic operation of clamp rotation

(1) Rotation depending on the sewing direction (during automatic sewing). The sewing machine of the clamp rotation model operates as follows.

Basic operation

The sewing machine sew in the sewing direction within the set angle range set in "Judgment angle θ_{LL} , θ_{LR} " based on "Sewing base angle of clamp θ_{BD} ".

If the sewing direction exceeds the set angle due to the shape of the sewing pattern, the clamp rotates in " θ_{BD} " direction so that the sewing direction is within the set angle.

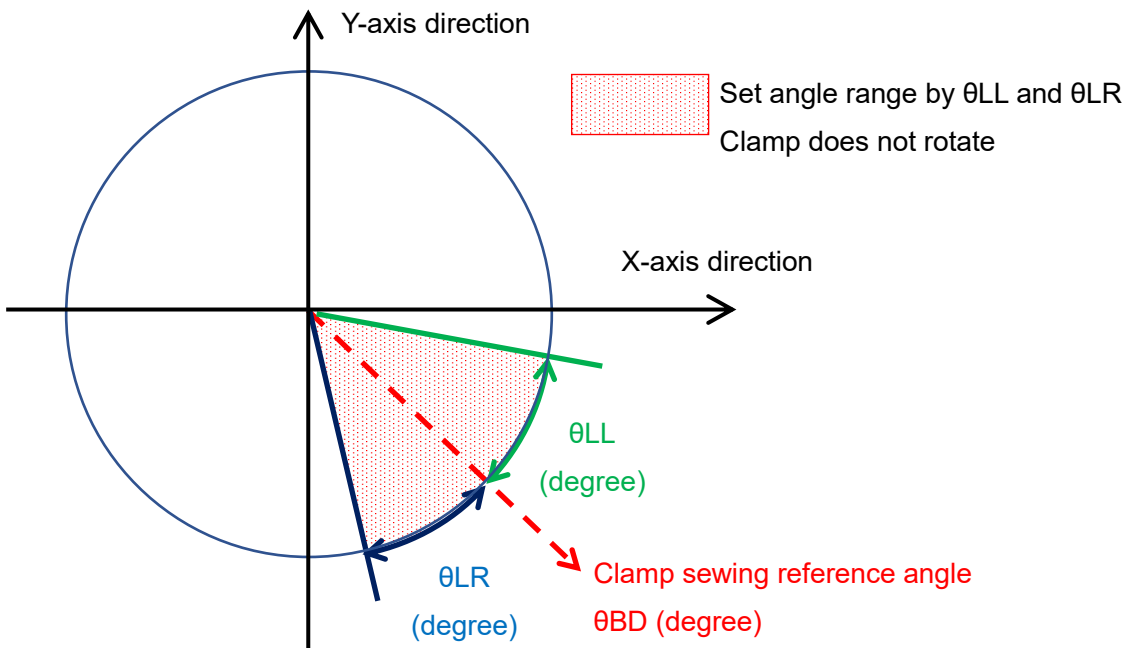

Note

" θ_{BD} ", " θ_{LL} ", and " θ_{LR} " can be set to any value in Program mode - wiper.

Please set " θ_{BD} ", " θ_{LL} ", and " θ_{LR} " according to the sewing direction required by the customer.

Note

" θ_{BD} " is set as the angle in CW direction with X-axis direction as 0 degrees.

" θ_{LL} " and " θ_{LR} " are set as angles with " θ_{BD} " direction as 0 degrees.

Operation example

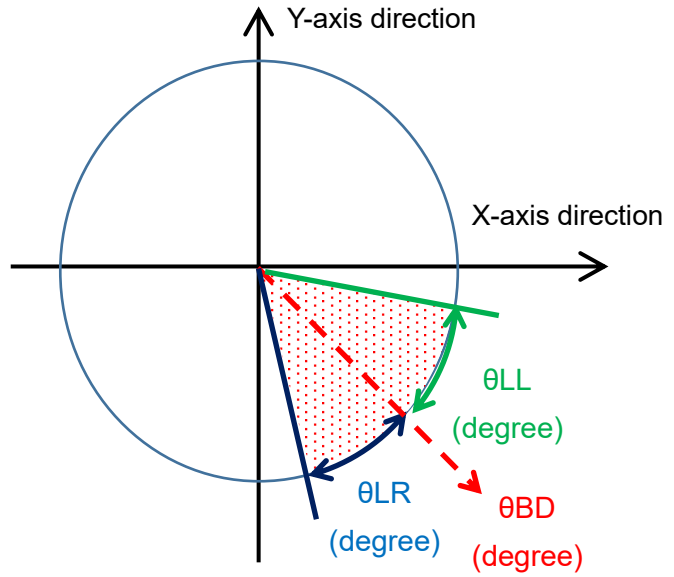
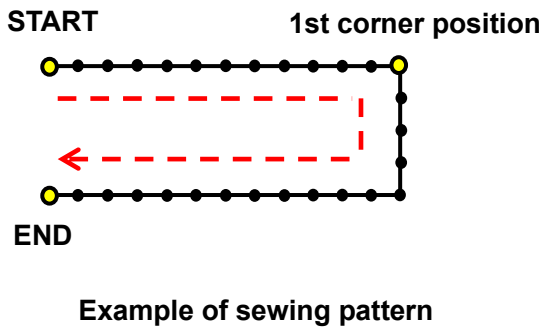

Condition example

- Program mode Operation mode $\theta_{RC} = 3$
- Sewing base angle of clamp $\theta_{BD} = 45$ degrees
- Judgement angle $\theta_{LL} = 30$ degrees, $\theta_{LR} = 30$ degrees
- Sewing pattern [90 degrees angle pattern]

[1] START position

Since the sewing direction exceeds the set angle at the START position, the clamp rotates so that the sewing direction is at " θ_{BD} " angle.

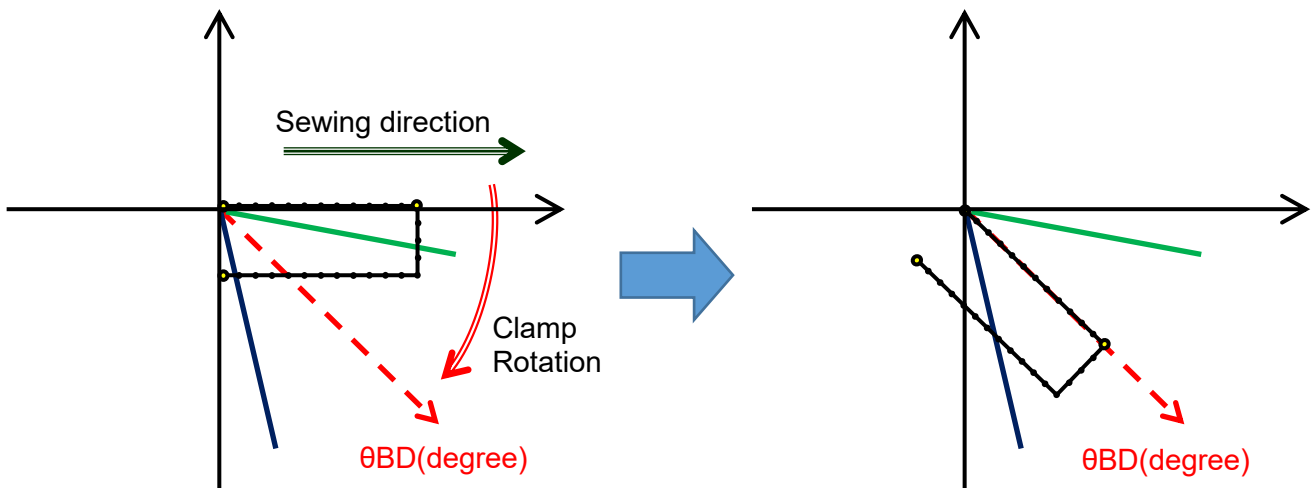

[2] Between the START position and the 1st corner position

The clamp does not rotate because the sewing direction is within the set angle.

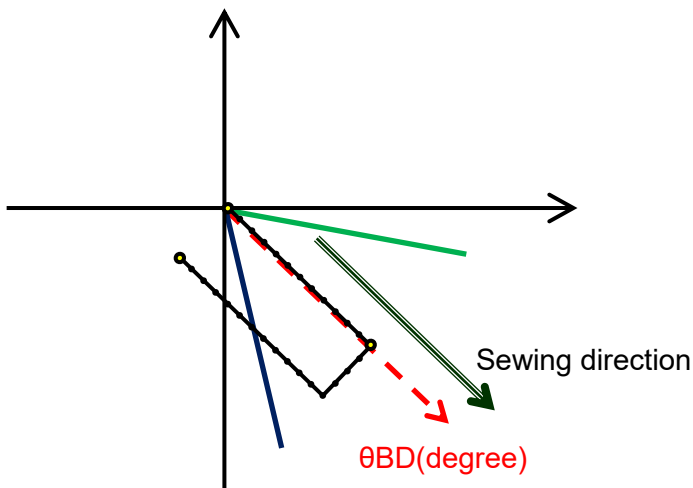

[3] Corner position

Since the sewing direction exceeds the set angle at the 1st corner position, the clamp rotates so that the sewing direction is at " θ_{BD} " angle."

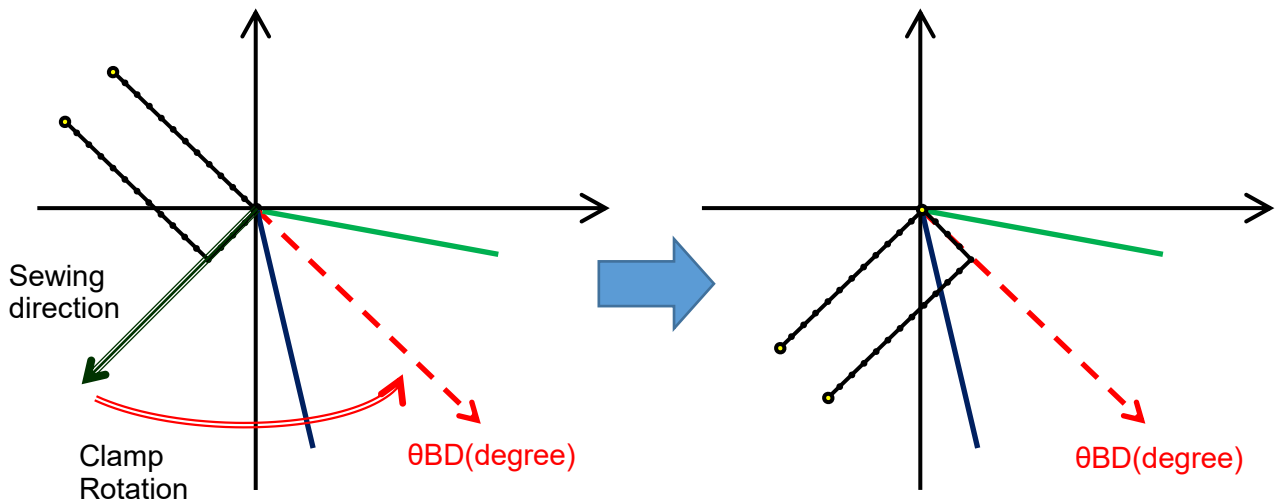

(2) Rotation by XY movement (jogging)

If the clamp moves XY during jogging, the clamp rotates in the X-axis direction.

Note

To rotate the clamp during jogging, please set program mode $\theta_{JE} = \text{ON}$.

5-3. Clamp rotation details

(1) Clamp rotation at a specific stitch position (speed code)

The clamp can be set to rotate only at the stitch position of the specific speed code on the sewing pattern.

By rotating only at a specific stitch position, the clamp rotates less frequently and sewing time is shortened.

Program mode-wiper θRP

$\theta RP = OFF$ setting

The clamp rotates at the stitch position of all speed cords.

$\theta RP = MD2$ setting

The clamp rotates only at the stitch position of MD2 cord.

* The clamp does not rotate at the stitch positions of L, H, MD1 code.

(2) Clamp rotation timing

The rotation timing of clamp can be set at the stitch position where the clamp rotates.

Program mode-wiper θRT

$\theta RT = 0$ setting At the stitch position where the clamp rotates, the clamp rotates after sewing.

One stitch before the rotation stitch position

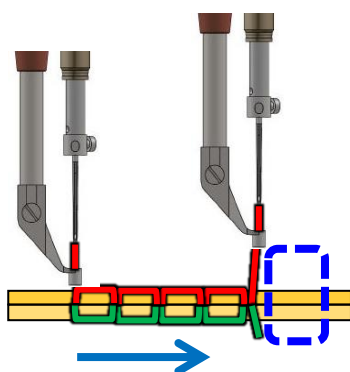

Rotation position

Rotation stitch position

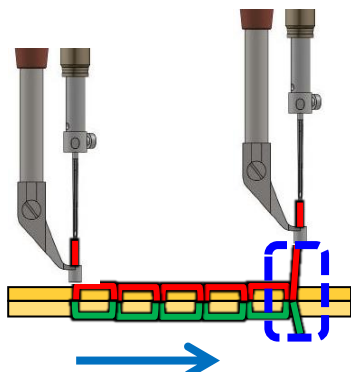

Rotation position



Clamp rotates after sewing

$\theta RT = 1$ setting

At the stitch position where the clamp rotates, the clamp rotates before sewing.

One stitch before the rotation stitch position

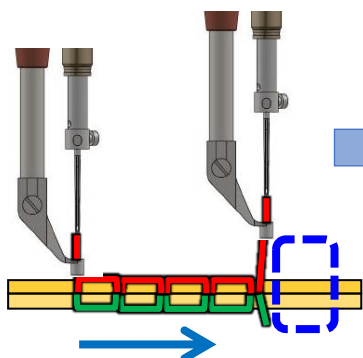

Rotation stitch position



Clamp rotates before sewing

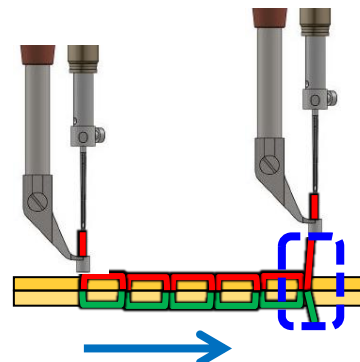

6. MAINTENANCE



- (1) Please make sure to turn the power switch off before cleaning the sewing machine.
- (2) Please pay attention to that staining your skin or eyes with oil may cause an inflammation.

6-1. Cleaning

Remove the dust and the thread waste sticking on the perfect stitch unit regularly.

6-2. Greasing

- (1) The dust or the like sticking absorbs lubrication oil on the rails and significantly lowers the slide guide running life. Remove the dust and the thread waste sticking on the slide guide which has perfect stitch unit regularly and greasing every six months. For the guide rail, grease to the both side of guide groove. After greased, apply the grease uniformly by moving the XY table by hand.

Recommended grease: Lithium grease 2

- (2) Grease every six months to inner periphery of the guide plate which has bottom side of the turn table unit. Please wipe off the old grease when put the new grease.

Recommended grease: Molybdenum disulfide grease

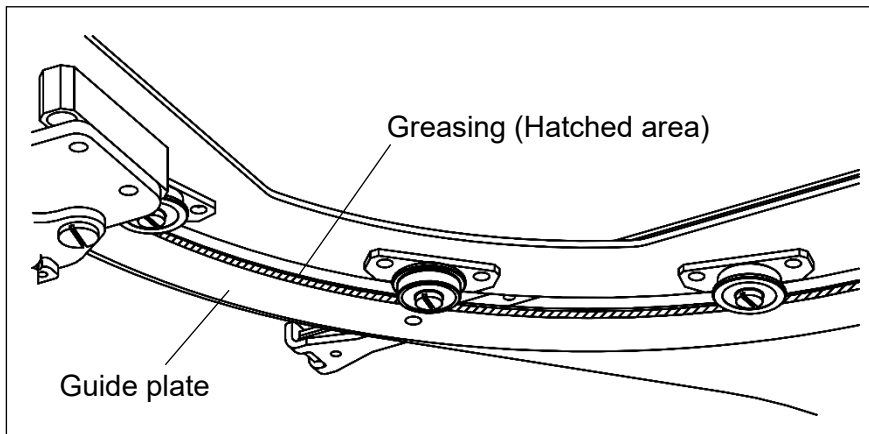

APPENDIX 1

Program mode list

Wiper

Function	Unit	Setting range	Specification
θRC Perfect stitch motion mode	Set the perfect stitch motion mode.		
	-	0	DO NOT USE.
		1	DO NOT USE.
		2	DO NOT USE.
3		The clamp rotates when the needle is up position. Valid set the sewing base angle with [θBD]. Valid set the judgement angle with [θLL] and [θLR].	
θRD DO NOT USE.	x0.1 deg.	0 to 1800	DO NOT USE.
θLL Judgment angle (CCW direction)	x0.1 deg.	0 to 1800	Set the amount of change for sewing direction to rotate clamp. (CCW direction)
θLR Judgment angle (CW direction)	x0.1 deg.	0 to 1800	Set the amount of change for sewing direction to rotate clamp. (CW direction)
θDP DO NOT USE.	x0.1 deg.	0 to 1800	DO NOT USE.
θSR Rotation speed of clamp	-	1 to 100	Set the rotation speed of the clamp during automatic sewing.
θFE Acceleration and deceleration distance for clamp rotation	-	1 to 100	Set the acceleration and deceleration distance for clamp rotation during automatic sewing.
θRT Rotation timing of clamp	Set the rotation timing of the clamp during automatic sewing.		
	-	0	The clamp rotates after sewing.
		1	The clamp rotates before sewing.
θJE Clamp rotation motion setting in JOG	Set valid/invalid the clamp rotation motion in JOG.		
	-	OF	The clamp does not rotate in JOG.
		ON	The clamp rotates in JOG.
θBD Sewing base angle of clamp	x0.1 deg.	0 to 3599	Set the sewing base angle of clamp during automatic sewing.
θRP Setting the clamp rotation at the specific stitch position	Set to rotate the clamp only at the specific stitch position.		
	-	OF	The clamp rotates at all stitch positions.
		MD2	The clamp rotates only at the stitch position of MD2 code.

Error display

[E-****] Error code

- When the error message is displayed, confirm the contents and investigate according to the following table.
- The machine can be restored to the normal mode by turning off the power once and turning on again.
- For other errors, refer to "Technical manual Operation Panel".

CODE	ERROR NAME	PROBABLE CAUSE	INSPECTION
E-3098	ADDITIONAL MOTOR OVER CURRENT 1	<ul style="list-style-type: none"> · Wiring to the P1 axis stepping motor is short circuited. · The load on the clamp rotation mechanism is too large. 	<ul style="list-style-type: none"> · Check wiring of the P1 axis stepping motor. · Check the sewing machine.
E-3100	ADDITIONAL MOTOR ENCODER ERROR 1	<ul style="list-style-type: none"> · The P1 axis encoder connector has not been firmly inserted. · The signal from the P1 axis encoder has been disconnected. 	<ul style="list-style-type: none"> · Check the insertion of the connector. · Check the encoder signal by using IN/OUT setting mode.
E-3113	ADDITIONAL MOTOR A PHASE ADSORPTION ERROR 1	<ul style="list-style-type: none"> · The clamp rotation mechanism (P1 axis stepping motor) is in contact with an obstacle. 	<ul style="list-style-type: none"> · Check the clamp rotation mechanism (P1 axis stepping motor).

付録 2

Appendix 2

部品カタログ

Parts Catalog

Model: MP-J25-PS Perfect stitch unit

目次	Page
A モータ駆動部 Motor drive unit component.....	1
B 回転駆動部 Clamp rotating unit.....	3
C 回転テーブル部 Turn table unit.....	5
D クランプ装置 Jig clamp unit.....	7
E スベリ板支え、付属品関係 Table support & accessories.....	9
F オプションパーツ Option parts.....	11

A モータ駆動部
MOTOR DRIVE UNIT COMPONENT

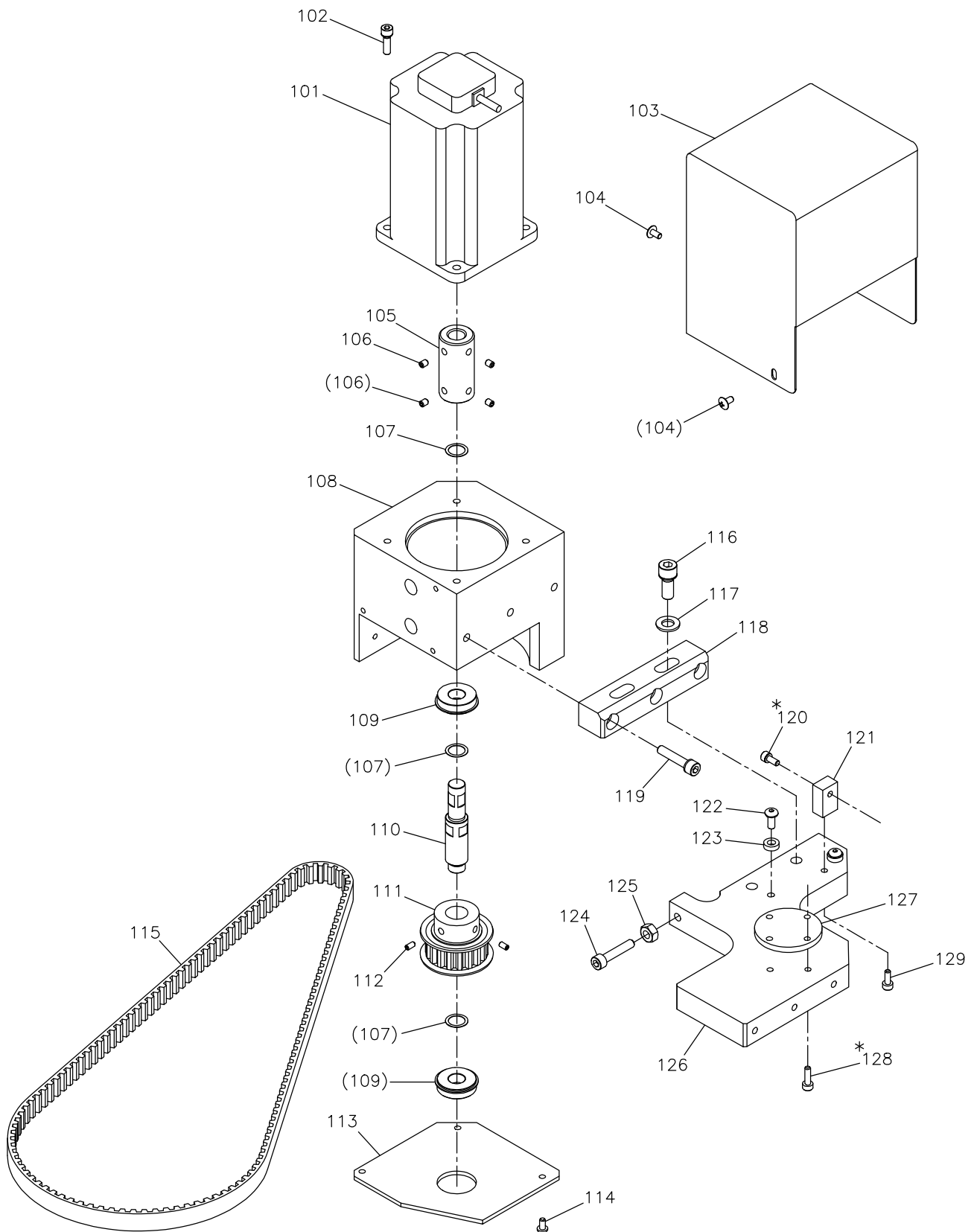

[A]モータ駆動部

MOTOR DRIVE UNIT COMPONENT

Fig no.	変更 Mod.	部品コード Parts no.	品名	Description	数量 Amt. Req.
☆ A 101		MP25P0848	ステッピングモータミタテ	Motor complete	1
A 102		M95022017	セフティソケット M5X20	Safety socket bolt M5X20	4
☆ A 103		MP25P0849	モータカバー	Motor cover	1
A 104		M90403036	トラスネジ M4X8	Truss screw M4X8	3
A 105		MH40A1750	ブッシュ	Coupling	1
A 106		M96002001	トメネジ M6X6	Set screw M6X6	4
☆ A 107		MP25P0915	シムリング	Shim ring	3
☆ A 108		MP25P0850	モータダイ	Motor base	1
A 109		MH40A0456	ボールベアリング	Ball bearing	2
☆ A 110		MP25P0390	ドライブシャフト	Drive shaft	1
☆ A 111		MP25P0767	タイミングプーリー	Cog pulley	1
A 112		M95001020	ロッカクアナツキトメネジ M5X10	Set screw M5X10	2
☆ A 113		MP25P0758	プーリーブラケット	Pulley bracket	1
A 114		M94036021	ロッカクアナツキボタンボルト M4X10	Button bolt M4X10	3
☆ A 115		MP25P0523	タイミングベルト	Cog belt	1
A 116		M98092021	ロッカクアナツキボルト M8X40	Socket bolt M8X40	2
A 117		M90843050	ミキキサガネ 8	Large washer 8	2
☆ A 118		MP25P0165	アダプタ1	Adapter 1	1
A 119		M96007017	セフティソケット M6X30	Safety socket bolt M6X30	3
A 120		M94033017	セフティソケット M4X12	Safety socket bolt M4X12	1
☆ A 121		MP25P0426	モータダイササエ	Motor base support	1
A 122		M95049021	ロッカクアナツキボタンボルト M5X12	Button bolt M5X12	2
A 123		MG75A1476	スペーサ	Spacer	2
A 124		M91558022	ロッカクアナツキボタンボルト M6X45	Button bolt M6X45	1
A 125		M91583045	ナット M6	Nut M6	1
☆ A 126		MP25P1426	モータダイササエ	Motor base support	1
☆ A 127		MP25P1165	アダプタ4	Adapter 4	1
A 128		M94057021	ロッカクアナツキボルト M4X20	Socket bolt M4X20	4
A 129		M94056021	ロッカクアナツキボルト M4X16	Socket bolt M4X16	1

B 回転駆動部
CLAMP ROTATING UNIT

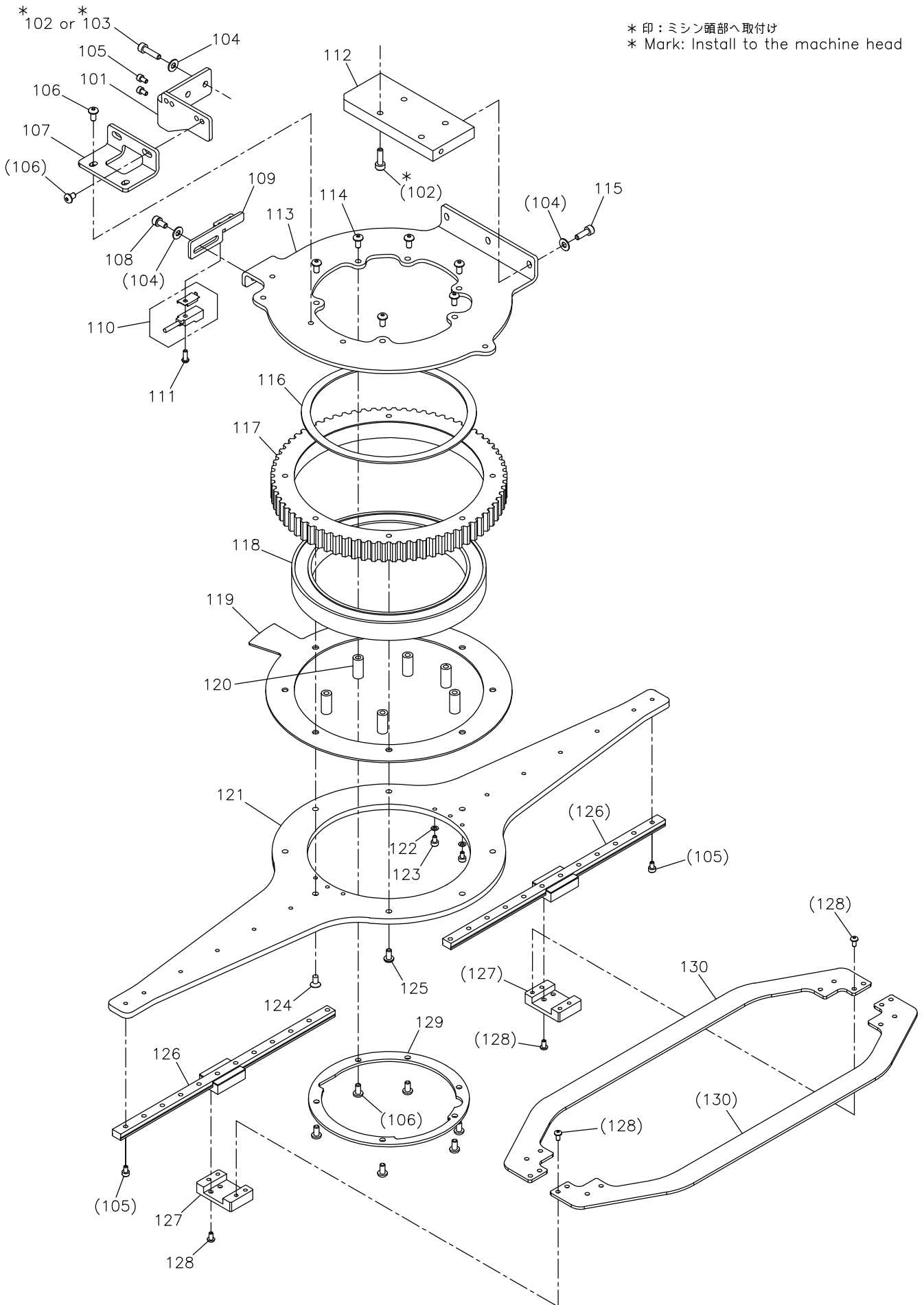

[B]回転駆動部

CLAMP ROTATING UNIT COMPONENT

Fig no.	変更 Mod.	部品コード Parts no.	品名	Description	数量 Amt. Req.
☆ B 101		MP25P0429	ササエカナグ ²	Bracket 2.....	1
B 102		M94056021	ロッカクアナツキホルト M4X16.....	Socket bolt M4X16.....	6
B 103		M94053021	ロッカクアナツキホルト M4X10.....	Socket bolt M4X10.....	2
B 104		M90463050	ミカキサガネ 4.....	Large washer 4.....	7
B 105		M93026021	ロッカクアナツキホルト M3X6.....	Socket bolt M3X6.....	16
B 106		M94041021	ロッカクアナツキホルタンホルト M4X6.....	Button bolt M4X6.....	10
☆ B 107		MP25P1429	ササエカナグ ¹	Bracket 1.....	1
B 108		M94031017	セフティソケット M4X8.....	Safety socket bolt M4X8.....	2
☆ B 109		MP25P0601	ケンシュツキトリツケイタ.....	Detector bracket.....	1
☆ B 110		MP25P0484	キンセツスイッチ.....	Detector.....	1
B 111		M91606022	ロッカクアナツキホルタンホルト M3X10.....	Button bolt M3X10.....	1
☆ B 112		MP25P2165	アダプ ² タ.....	Adapter 2.....	1
☆ B 113		MP25P0770	プーリベース.....	Pulley base.....	1
B 114		M94005022	ロッカクアナツキホルタンホルト M4X8.....	Button bolt M4X8.....	6
B 115		M94054021	ロッカクアナツキホルト M4X12.....	Socket bolt M4X12.....	3
☆ B 116		MP25P0476	スペーサA.....	Spacer A.....	1
☆ B 117		MP25P1767	タイミングプーリ.....	Cog pulley.....	1
☆ B 118		MP25P0456	ベアリング.....	Ball bearing.....	1
☆ B 119		MP25P1476	スペーサB.....	Spacer B.....	1
☆ B 120		MP25P0449	エンケインチュウ.....	Circular post.....	6
☆ B 121		MP25P0391	クドウイタ.....	Drive arm.....	1
B 122		M90326050	コサガネ 3.....	Small washer 3.....	4
B 123		M93025021	ロッカクアナツキホルト M3X5.....	Socket bolt M3X5.....	4
B 124		M91062004	Pサラネジ ² M4X10.....	Countersunk screw M4X10.....	2
B 125		M94036021	ロッカクアナツキホルタンホルト M4X10.....	Button bolt M4X10.....	6
☆ B 126		MP25P0920	リニアガイド.....	Linear motion guide.....	2
☆ B 127		MP25P0750	ブロック.....	Block.....	2
B 128		M91608022	ロッカクアナツキホルタンホルト M3X5.....	Button bolt M3X5.....	16
☆ B 129		MP25P0771	ベアリングオサエ.....	Bearing holder.....	1
☆ B 130		MP25P0953	レンケツイタ.....	Connection plate.....	2

☆印はMP-J25-PS専用部品を示します。

☆ indicates MP-J25-PS special parts.

C 回転テーブル部
TURN TABLE UNIT

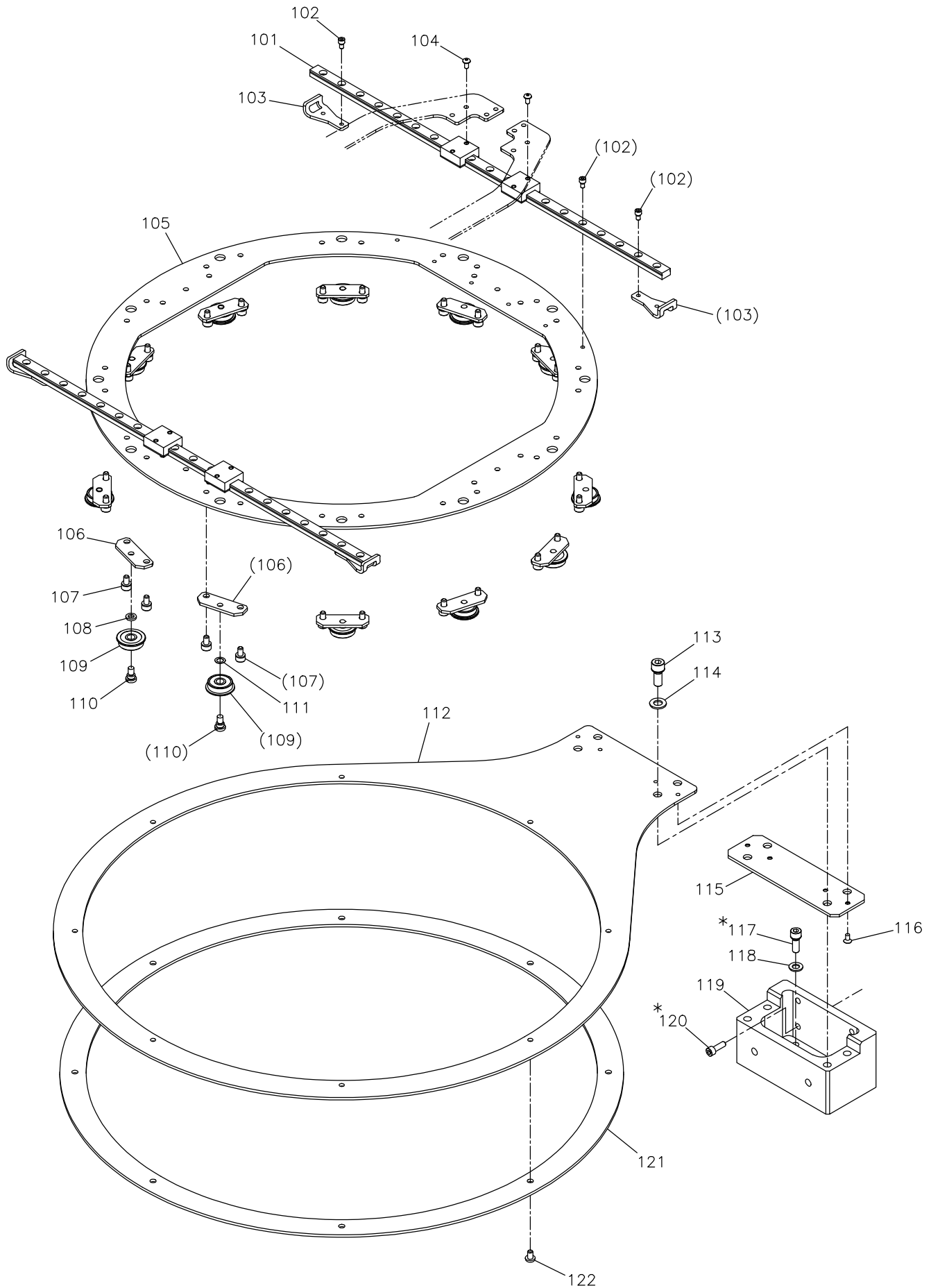

[C]回転テーブル部
TURN TABLE UNIT

Fig no.	変更 Mod.	部品コード Parts no.	品名	Description	数量 Amt. Req.
☆ C 101		MP25P1920	リアガイド	Linear motion guide	2
C 102		M93025021	ロックアナツキボルト M3X5	Socket bolt M3X5	20
☆ C 103		MP25P0477	ストッパ	Stopper	4
C 104		M91608022	ロックアナツキボルト M3X5	Button bolt M3X5	8
☆ C 105		MP25P0595	ターンテーブル	Turn table	1
☆ C 106		MP25P1770	ローベース	Roller base	12
C 107		M94050021	ロックアナツキボルト M4X5	Socket bolt M4X5	24
☆ C 108		MP25P1915	シムリング (T=0.8)	Shim ring (T=0.8)	6
☆ C 109		MP25P1456	ベアリング	Ball bearing	12
C 110		M91111015	ヒラネジダツキ	Shoulder bolt	12
☆ C 111		MP25P2915	シムリング (T=0.2)	Shim ring (T=0.2)	6
☆ C 112		MP25P0272	オクリイタ	Feed plate	1
C 113		M96076021	ロックアナツキボルト M6X16	Socket bolt M6X16	4
C 114		M90648050	コサガネ 6	Small washer 6	4
☆ C 115		MP25P2476	スペーサ	Spacer	1
C 116		M91304010	Pサラネジ M3X6	Countersunk screw M3X6	4
C 117		M95020017	セフティソケット M5X14	Safety socket bolt M5X14	4
C 118		M90527050	コサガネ 5	Small washer 5	4
☆ C 119		MP25P0308	イトウタイ	Base bracket	1
C 120		M94054021	ロックアナツキボルト M4X12	Socket bolt M4X12	4
☆ C 121		MP25P0359	ガイドイタ	Guide plate	1
C 122		M94041021	ロックアナツキボルト M4X6	Button bolt M4X6	8

D クランプ装置
JIG CLAMP UNIT

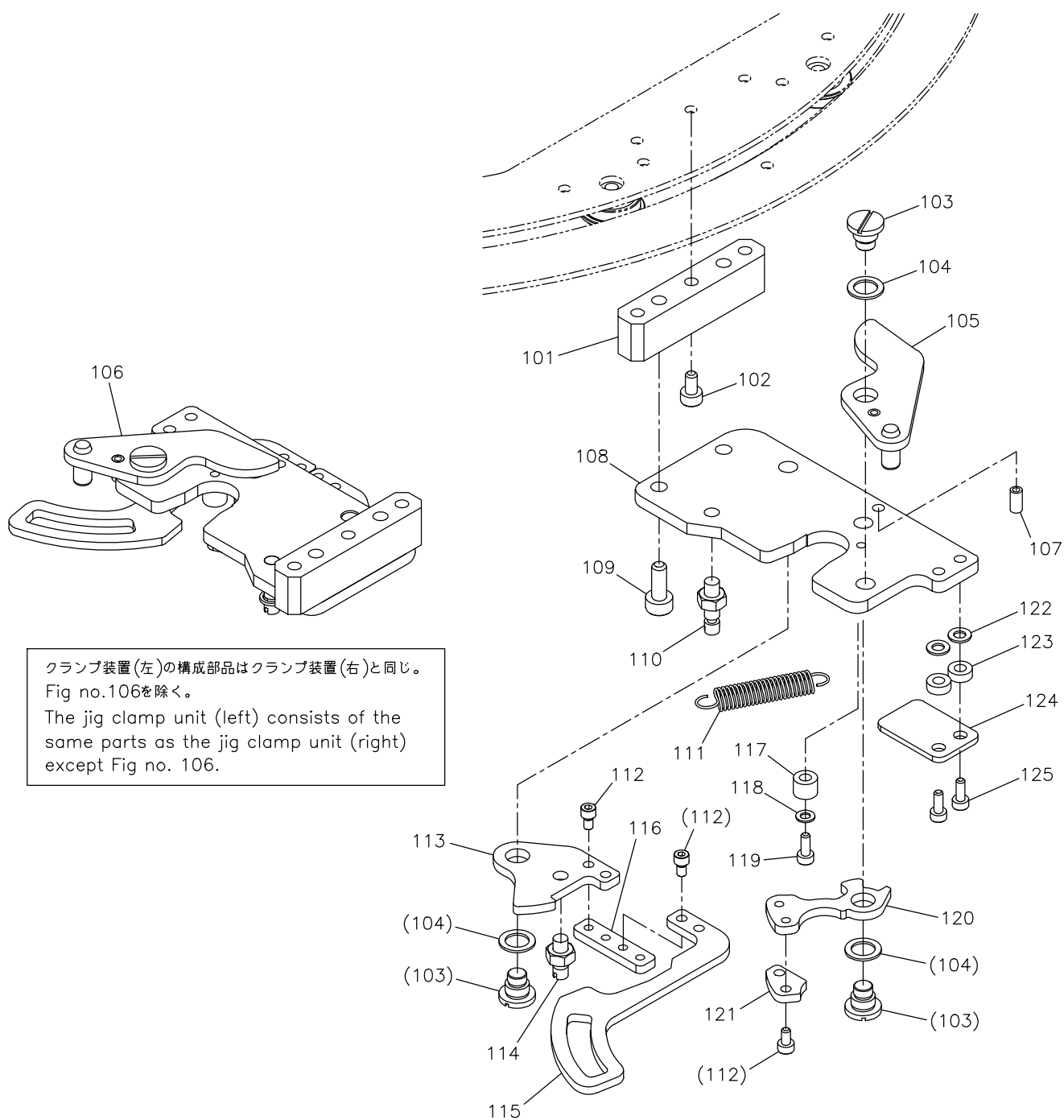

クランプ装置(左)の構成部品はクランプ装置(右)と同じ。
Fig no.106を除く。
The jig clamp unit (left) consists of the
same parts as the jig clamp unit (right)
except Fig no. 106.

クランプ装置(右)
The jig clamp unit (right)

[D]クランプ装置
JIG CLAMP UNIT

Fig no.	変更 Mod.	部品コード Parts no.	品名	Description	数量 Amt. Req.
☆ D 101		MP25P3165	アダプタ3	Adapter 3	2
D 102		M94033017	セフティソケット M4X12	Safety socket bolt M4X12	6
D 103		M91690015	ヒラネジダんツキ	Screw	6
☆ D 104		M98004052	ウェーブワッシャ	Wave washer	6
☆ D 105		MP25P0950	クランプレバー3 ミキ	Clamp lever 3 right	1
☆ D 106		MP25P1950	クランプレバー3 ヒダリ	Clamp lever 3 left	1
☆ D 107		M90407064	スプリングピン Φ4X8	Spring pin 4X8	2
☆ D 108		MP25P0228	クランプアーム	Clamp arm	2
D 109		M95021017	セフティソケット M5X16	Safety socket bolt M5X16	4
☆ D 110		MP25P0708	ヒッパリハネヨウホスト	Post for tension spring	2
☆ D 111		MP25P0572	ヒッパリハネ	Tension spring	2
D 112		M93026021	ロッカクアナツキホルト M3X6	Socket bolt M3X6	12
☆ D 113		MP25P2950	クランプレバー1	Clamp lever 1	2
D 114		MH60W0786	ヒッパリハネヨウホスト	Post for tension spring	2
☆ D 115		MP25P3950	クランプレバー4	Clamp lever 4	2
☆ D 116		MP25P0571	ツギテ	Connecting plate	2
☆ D 117		MP25P0352	カラー	Collar	2
D 118		M90326050	コサガネ 3	Small washer 3	2
D 119		M93028021	ロッカクアナツキホルト M3X10	Socket bolt M3X10	2
☆ D 120		MP25P4950	クランプレバー2	Clamp lever 2	2
☆ D 121		MP25P0257	オサエイタ	Holder	2
D 122		M90462050	コサガネ 4	Small washer 4	4
☆ D 123		MP25P1352	カラー	Collar	4
☆ D 124		MP25P2429	ササエイタ	Support plate	2
D 125		M94032017	セフティソケット M4X10	Safety socket bolt M4X10	4

E スペリ板支え、付属品関係
TABLE SUPPORT & ACCESSORIES

* 印：マシンベッドへ取付け
 * Mark: Install to the machine bed

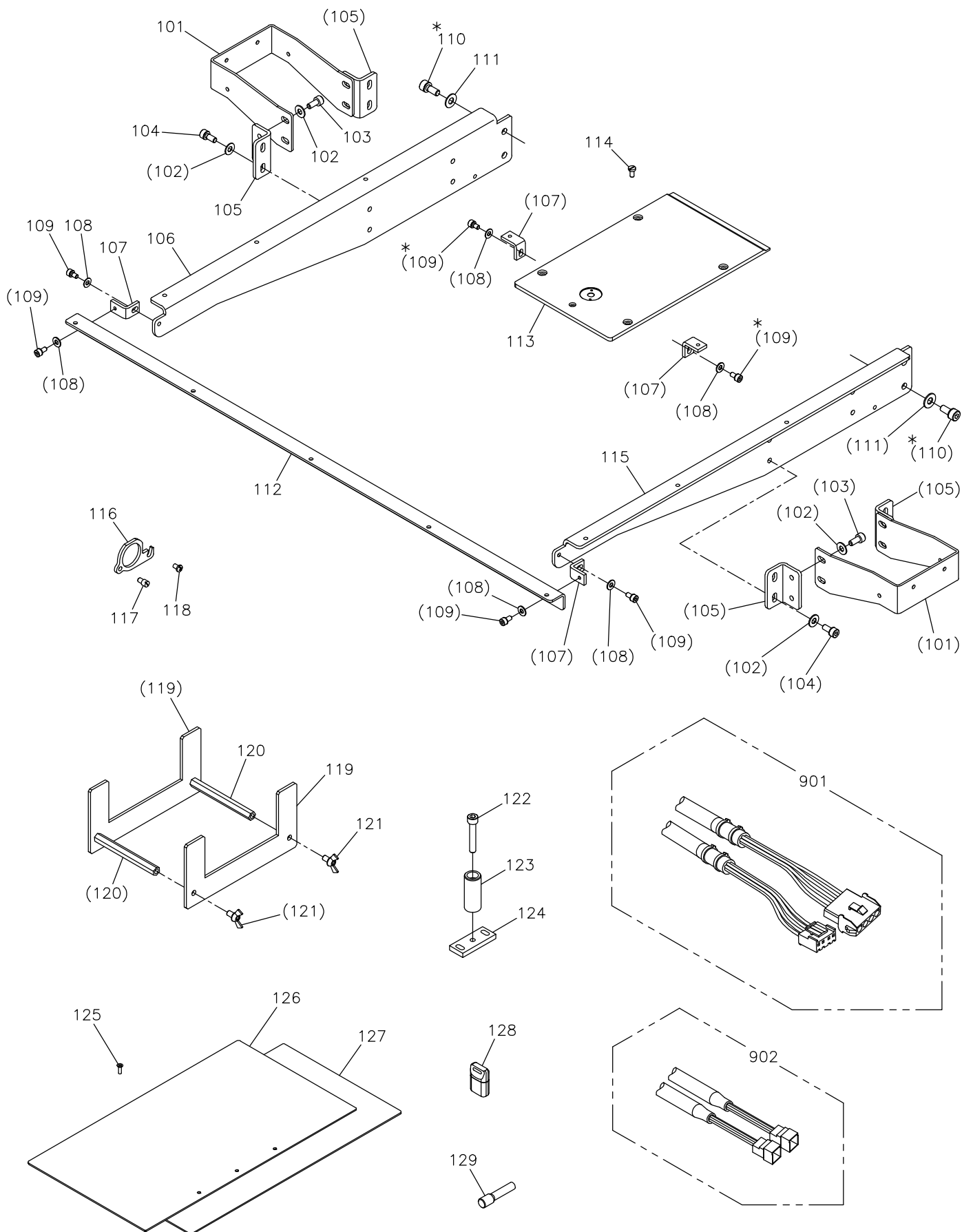

[E]スベリ板支え、付属品関係
TABLE SUPPORT & ACCESSORIES

Fig no.	変更 Mod.	部品コード Parts no.	品 名	Description	数量 Amt. Req.
☆ E 101		MP25P2426	カバーササエ	Cover support	2
E 102		M90518050	ミガキサガネ 5	Large washer 5	16
E 103		M95017017	セフティソケット M5X8	Safety socket bolt M5X8	8
E 104		M95018017	セフティソケット M5X10	Safety socket bolt M5X10	8
E 105		MJ15A1361	L型カナグ	L-type bracket	4
☆ E 106		MP25P3429	ササエカナグ ヒダリ	Support bracket left	1
E 107		MB62A4601	トリツケイタ	Adapter	4
E 108		M90463050	ミガキサガネ 4	Large washer 4	6
E 109		M94031017	セフティソケット M4X8	Safety socket bolt M4X8	6
E 110		M96015017	セフティソケット M6X12	Safety socket bolt M6X12	4
E 111		M90648050	コサガネ 6	Small washer 6	4
☆ E 112		MP25P0799	ホキョウイタ	Stiffening plate	1
☆ E 113		MP25P0472	スベリイタ	Slide plate	1
E 114		M90990002	ヒラネジ M4X8	Flat screw M4X8	4
☆ E 115		MP25P4429	ササエカナグ ミキ	Support bracket right	1
☆ E 116		MP25P0780	ホルダ	Holder	1
E 117		M91111033	ピンネジ 11/64(40)	Pin 11/64(40)	1
E 118		M91054004	SW-PW プライマインベネジ M4X8	SW-PW pan screw M4X8	1
☆ E 119		MP25P0389	クミタテジグ	Assembly jig	2
☆ E 120		MP25P1449	ロッカクシチュウ	Hexagonal post	2
☆ E 121		M95002025	チョウホルト	Wing bolt	4
☆ E 122		M96074021	ロッカクアナツキホルト M6X35	Socket bolt M6X35	2
☆ E 123		MP25P0196	イチキメピン	Locating pin	2
☆ E 124		MP25P1780	ホルダ	Holder	2
E 125		M90862004	Pサラネジ M3X12	Countersunk screw M3X12	6
☆ E 126		MP25P0339	Xカバーイタ ヒダリ	X-cover plate left	1
☆ E 127		MP25P1339	Xカバーイタ ミキ	X-cover plate right	1
☆ E 128		MJ25J0991	USBメモリ	USB memory	1
E 129		MB62A0757	プラグ	Plug	1
☆ E 901		MP25P0508	モータケーブル	Motor cable	1
☆ E 902		MP25P1508	エンコーダケーブル	Encoder cable	1

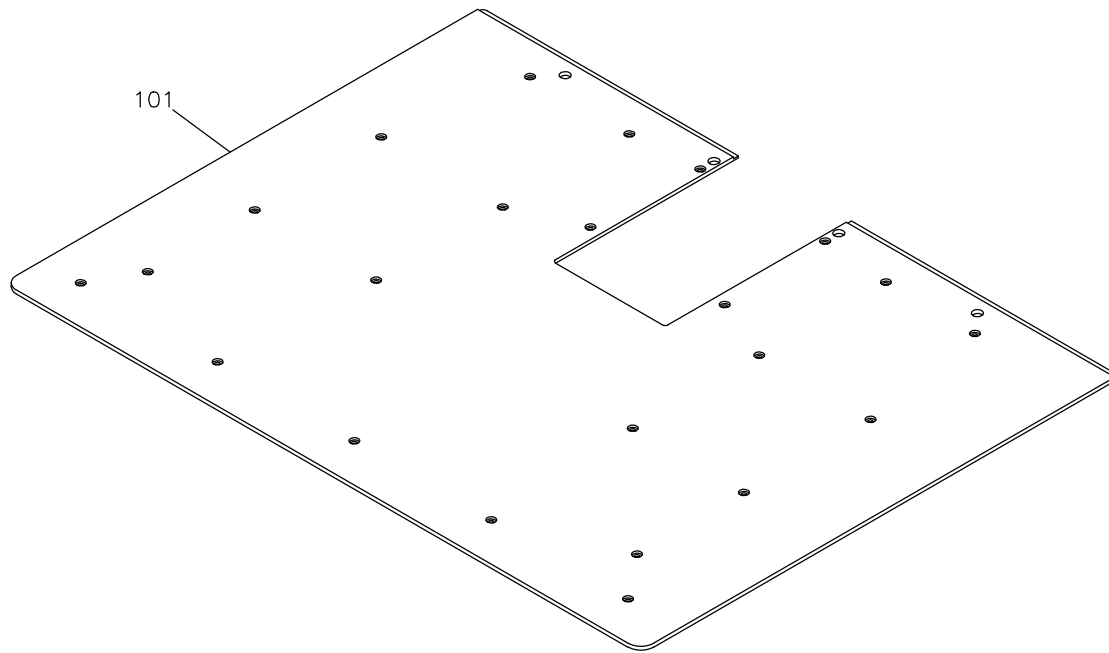

[F]オプションパーツ
OPTION PARTS

Fig no.	変更 Mod.	部品コード Parts no.	品 名	Description	数量 Amt. Req.
☆ F 101		MP25P0470	スベリイタ (ガラスエポキシ樹脂製) ……	Slide plate (Glass epoxy resin) ……	1

APPENDIX 3

Dimensional drawing of slide plate

Material: Glass epoxy resin (t=4mm)

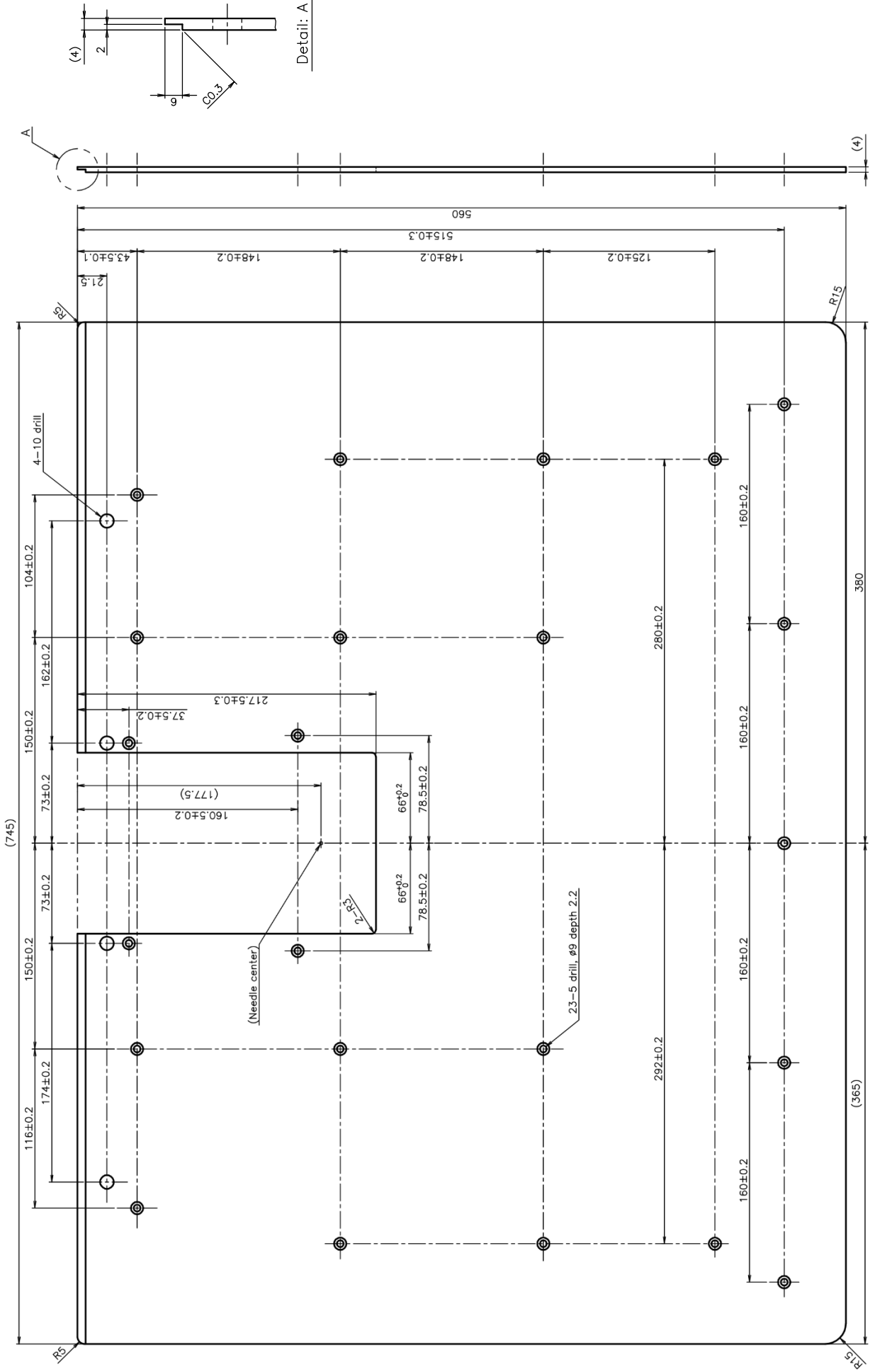

JUKI CORPORATION

Printed in Japan