

JUKI®

INDUSTRIAL SEWING MACHINE
Attachment

MODEL

MP-G10-AT

MP-G20-AT

MP-G40-AT

TECHNICAL MANUAL

Pneumatic 2-step Tensioner



FOR SAFE USE

Before the installation, operation, and inspection for this product, read the “FOR SAFE USE” and the technical manuals carefully. Also read the other technical manuals, “Sewing Machine Head”, “Control Unit” and “Operation Panel” describing some instructions, which are not in this manual, and use the sewing machine properly.

SAFETY INDICATIONS

	<p>CAUTION</p> <p>Indicates that incorrect handling may cause hazardous conditions, resulting in medium or slight personal injury or physical damage. Note that CAUTION level may lead to a serious consequence according to the circumstances. Always follow the instructions of both levels because they are important to personal safety.</p>
---	---

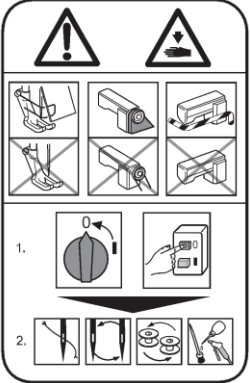
CAUTION INDICATIONS

No.	Caution indication	Description
1		<p><u>Precaution for sewing machine operation:</u></p> <p>Indicates that removing the safety and operating the sewing machine for some other purposes with power-on are prohibited.</p> <ul style="list-style-type: none"> ● Please do not operate the sewing machine without protective equipment such as a needle guard, an eye guard, a belt cover or the others. ● Please turn off the power switch when threading, changing a needle and a bobbin, cleaning, and lubricating.
2		<p><u>Caution for fingers injury:</u></p> <p>Indicates a possibility of fingers (hands) injury in a certain condition.</p>
3		<p><u>Caution for squeezing fingers:</u></p> <p>Indicates a possibility of squeezing fingers in a certain condition.</p>

1. Features

It allows you to load in two stages the tension of the upper thread. Differences in the thread tension, caused by changes in the stitching direction or thickness, are eliminated.

2. Applicable models

Name	Applicable models
MP-G10-AT	PLK-G1010
MP-G20-AT	PLK-G2010R/G2516/G2516R/G2516-YU
MP-G40-AT	PLK-G4030/G4030R/G6030/G6030R PLK-G5050/G5050R/G10050/G10050R

3. Specifications

Cylinder stroke		: 5mm
Control power supply		: DC24V
Drive source air pressure	Primary side	: 0.5 MPa (5 kgf /cm ²) or more
	Secondary side	: 0.4 MPa (4 kgf /cm ²)



CAUTION

Trouble such as operation errors could occur if the secondary pressure is set too high.
Use within the range of 0.4 MPa (4 kgf /cm²).

4. Configuration

The Fig. numbers in the drawing correspond to the part numbers given in the following explanations.
When ordering service parts, please specify in the Parts No. (M*****).

4.1 Pneumatic 2-step tensioner mechanism

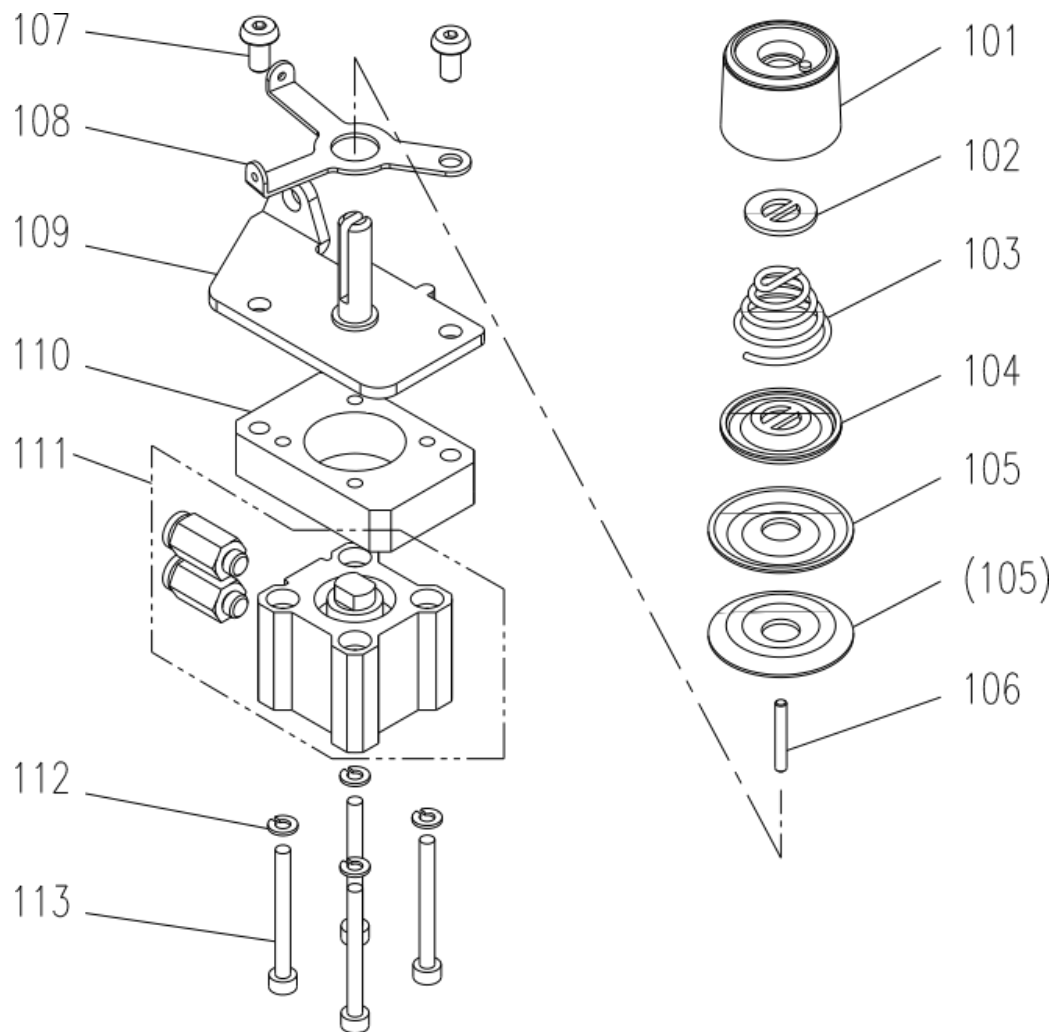

4.1 Pneumatic 2-step tensioner mechanism (Parts list)

Fig No.	部品コード Parts No.	品名	Description	数量 Amt. Req.
101	M91610046	ツミネジ	Thumb nut	1
102	MT60A0802	マワリ止め	Thumb nut revolution stopper	1
103	MN52A1245	エンスイバネ	Thread tension spring	1
104	MH40A0556	チョウシガラオサエ	Disc retaining plate	1
105	MF10A0555	チョウシガラ	Thread tension discs	2
106	M90235060	ピン	Pin	1
107	M94036021	ロッククアナツキホルト M4X10	Screw M4X10	2
108	MH10W0181	イトアンナイ	Thread guide	1
109	ME10T0175	チョウセツキトリツケイタ	Bracket	1
110	ME10T0476	スペーサ	Spacer	1
111	ME10T0434	ウスカタシリンダ	Air cylinder	1
112	M90307053	ハネサガネ 3	Washer 3	4
113	M93008021	ロッククアナツキホルト M3X30	Screw M3X30	4

4.2 Pneumatic pressure control unit

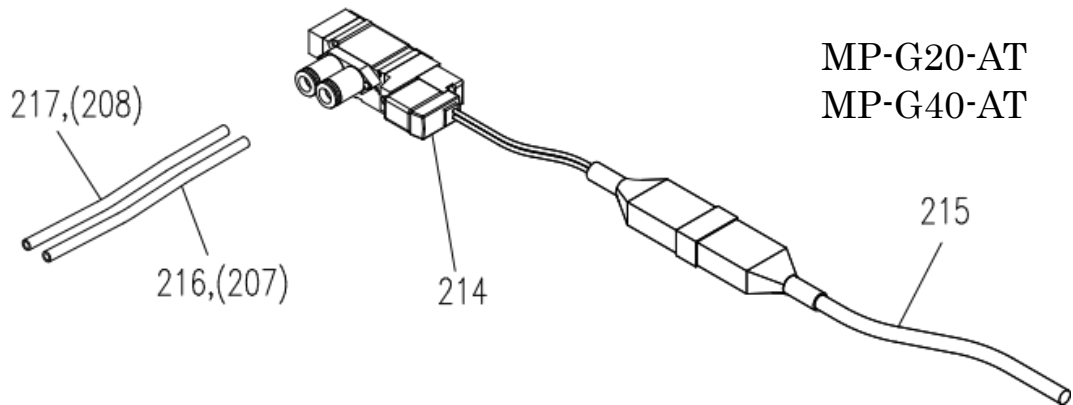
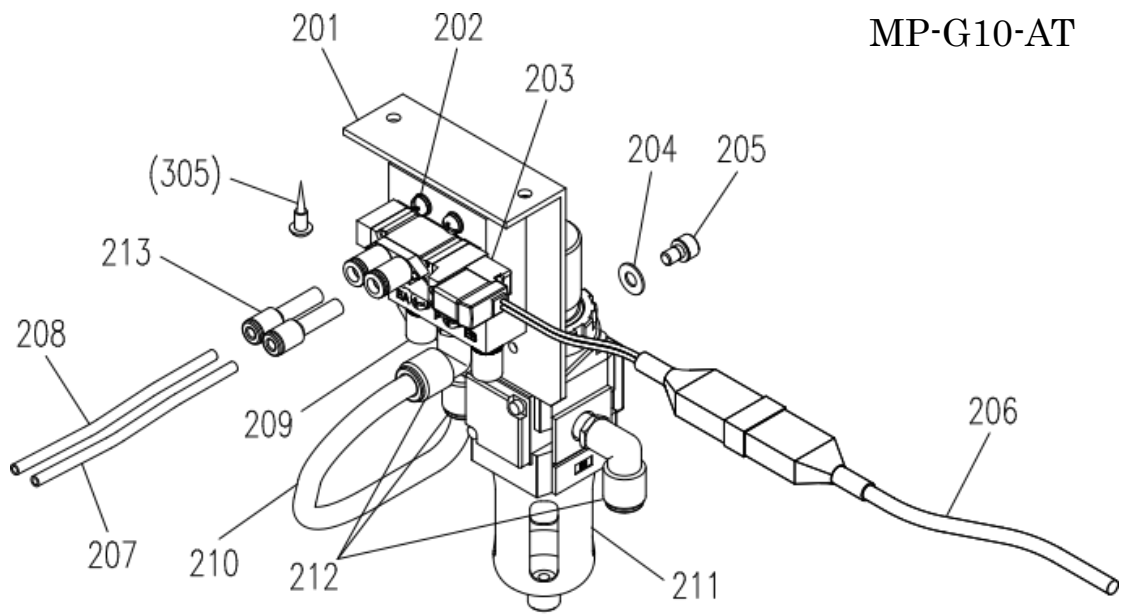

4.3 Accessories

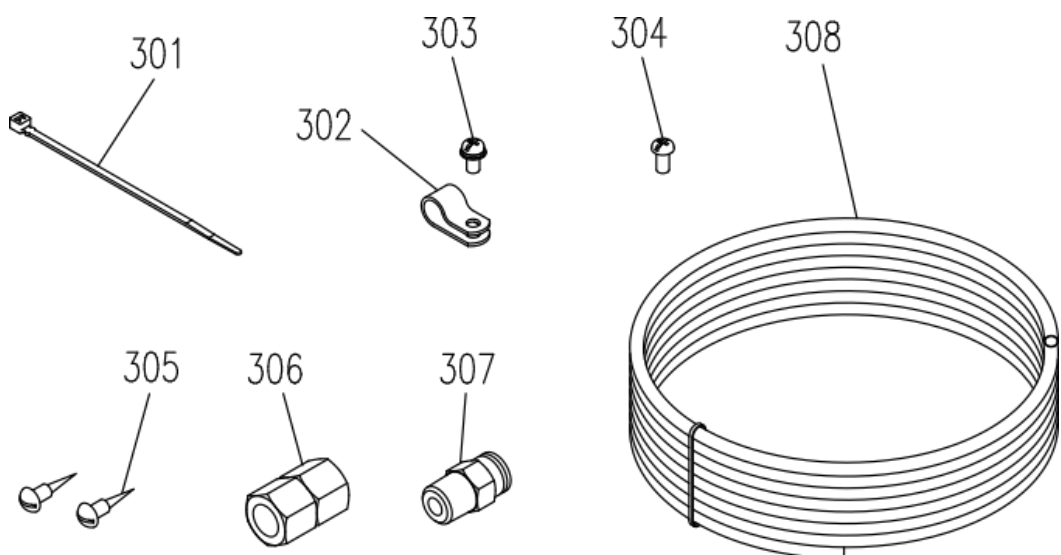

4.2 Pneumatic pressure control unit (Parts list)

Fig No.	部品コード Parts No.	品名	Description	数量 Amt. Req.		
				G10 -AT	G20 -AT	G40 -AT
201	MH25A1601	デンジベントリツケイタ	Valve mounting plate	1		
202	M91066004	SW-PW プラマイナベネジ M4X25	Screw M4X25	4		
203	ME10X0599	デンジベソクミタテ	Solenoid valve assy	1		
204	M90511050	サガネ 5	Washer 5	2		
205	M95003017	セフティソケット M5X8	Safety socket bolt M5X8	2		
206	MH10W0508	セツゾクデンセンクミタテ	Cable assy	1		
207	MB10K4567	エアチューブクミタテ(A)	Air tube assy (A)	1	1	
208	MB10K5567	エアチューブクミタテ(B)	Air tube assy (B)	1	1	
209	M91035089	サイレンサ	Muffler	2		
210	MB20P1567	エアチューブ	Air tube	1		
211	ME40A0963	フィルタレギュレータ	Filter regulator	1		
212	MA20A8571	L ガタワンタッチツギテ	L-type quick joint	3		
213	MA30A0964	レジューサ	Reducer	2		
214	MB25S0599	デンジベソクミタテ	Solenoid valve assy		1	1
215	MH20A1508	セツゾクデンセンクミタテ	Cable assy		1	1
216	MH10W0567	エアチューブクミタテ(A)	Air tube assy (A)			1
217	MH10W1567	エアチューブクミタテ(B)	Air tube assy (B)			1

4.3 Accessories (Parts list)

Fig No.	部品コード Parts No.	品名	Description	数量 Amt. Req.		
				G10 -AT	G20 -AT	G40 -AT
301	MF06A1620	ケツソクバンド	Cable tie	5	5	5
302	MN60A0620	ナイロンクリップ 5	Nylon clip 5	5		6
303	M91056004	SW-PW プラマイナベネジ M4X10	Screw M4X10	5		6
304	M91069004	プラマイナベネジ M4X8	Screw M4X8	1	1	1
305	M90409041	マルモクネジ 4.5X20	Screw 4.5X20	2		
306	M91010089	ロッカソケット	Socket	1		
307	MA30A0571	ワンタッチツギテ	Quick joint	1		
308	MS06A0567	エアチューブ	Air tube	1		

5. Assembly procedures



CAUTION

- ★ To work in the presence of residual pressure in the pneumatic circuit It is dangerous. Please work after you remove the residual pressure always. The method of removing the residual pressure, and pull up the handle of the pressure regulating filter regulator, can be done by turning counter-clockwise until the pressure gauge shows 0.
- ★ When installing removal of parts, please go to turn off the power before. In addition, qualified personnel of electrical work, please be performed by wiring work.

5.1 Installing the Pneumatic 2-Step Tensioner

Please assembled as shown in Figure 1 is the Pneumatic 2-Step Tensioner. Remove the existing thread guide.

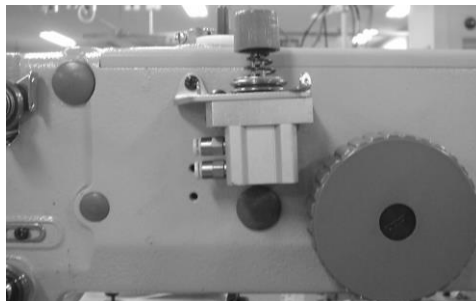

Fig.1

5.2 Installing the pneumatic pressure control related parts and piping (in the case of MP-G10-AT)

- (1) Please fix with two wood screws provided the pneumatic pressure control unit of sewing machine table underside as shown in Figure 2.
- (2) Pass the air tubes through the notched section on the side of the sewing machine unit's motor cover, and lead the tubes to the bottom of the table from the square hole on the table.
- (3) Insert to match the symbols A and B of the air tubes described above to the solenoid valve and the Pneumatic 2-Step Tensioner ,as shown in Figure 2 and 3.
- (4) Secure the sewing machine right air tube using the nylon clips of accessory ,as shown in Figure 3.

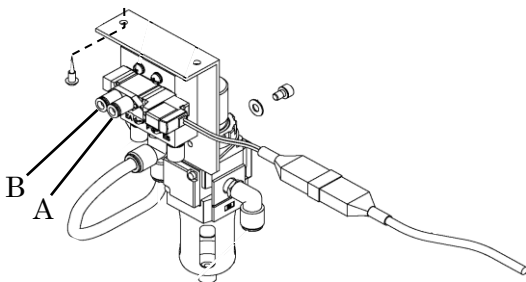

Fig.2

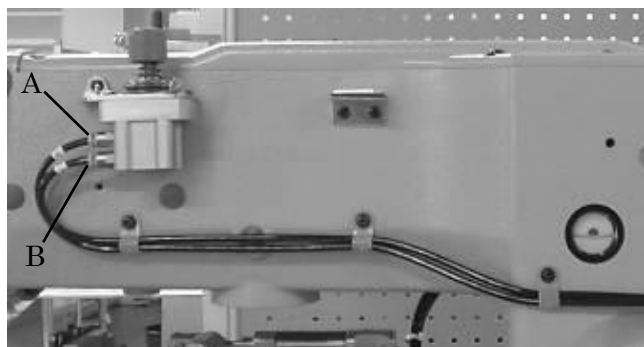

Fig.3

5.3 Installing the pneumatic pressure control related parts and piping (in the case of MP-G20-AT)

- (1) Turn the air pressure to 0 by turning the pressure adjustment knob of the filter regulator, and remove any residual pressure.
- (2) Remove the cover of the sewing machine body left side, remove the packing and C blanking plate D from the solenoid valve as shown in Figure 4, install the solenoid valve attached. At this time, attach the packing included with this in order to prevent air leakage.
- (3) Insert to match the symbols A and B of the air tubes to the solenoid valve and the Pneumatic 2-Step Tensioner ,as shown in Figure 4 and 5.
- (4) Secure the sewing machine left air tube using the cable ties of accessory.

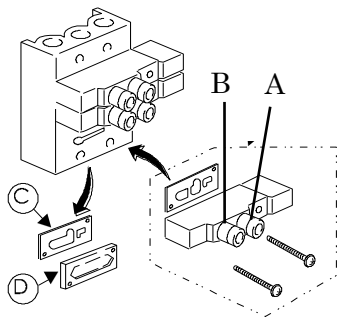

Fig.4

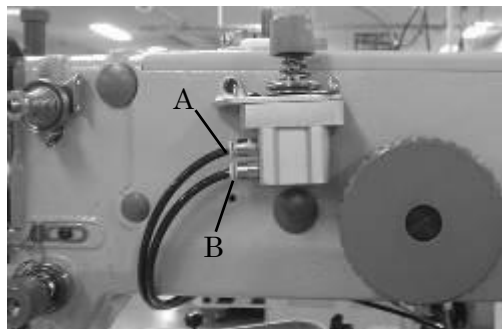

Fig.5

5.4 Installing the pneumatic pressure control related parts and piping (in the case of MP-G40-AT)

- (1) Turn the air pressure to 0 by turning the pressure adjustment knob of the filter regulator, and remove any residual pressure.
- (2) Remove the packing and C blanking plate D from the solenoid valve as shown in Figure 4, install the solenoid valve attached. At this time, attach the packing included with this in order to prevent air leakage.
- (3) Insert to match the symbols A and B of the air tubes to the solenoid valve and the Pneumatic 2-Step Tensioner ,as shown in Figure 4 and 6.
- (4) Secure the sewing machine right air tube using the nylon clips of accessory ,as shown in Figure 6.

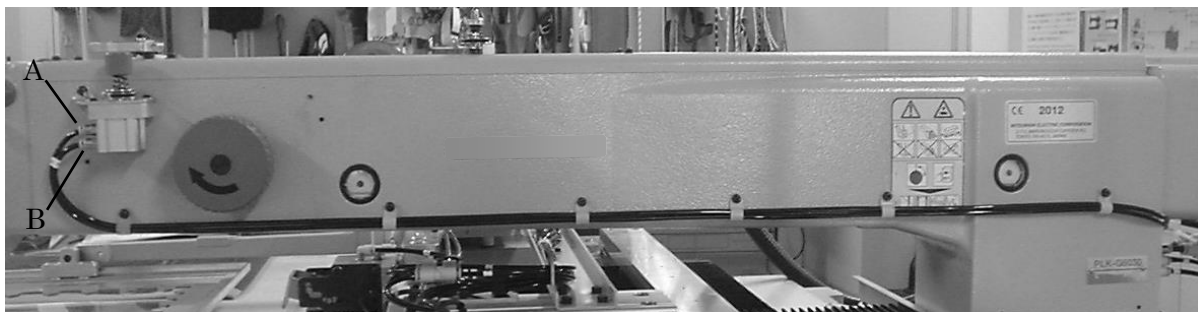

Fig.6

5.5 How to setup and cable connection

Insert the connector of the solenoid valve assembly in to the general purpose output connector CON M (15P).

CON M (General purpose output)

Function name	Default value		Pin No.
O8	FN1	Function code output 1	1
+24V	+24V	--	2

6. Operation



CAUTION

Assembly of this device is completed, please check your work once again.

Because there is a case to unexpected behavior, please away from the sewing machine when the power is turned on and the air pressure.

- (1) Pull up on the handle of the filter regulator, adjust to 0.4MPa(4kgf/cm²) air pressure by turning in a clockwise direction.
- (2) Pneumatic 2-Step Tensioner will work with to input code "FUN1" in the pattern.

For details, refer to the clause of the technical manual "Operation Panel".

JUKI CORPORATION

Printed in Japan