

JUKI®

INDUSTRIAL SEWING MACHINE
Attachment

MODEL

MP-G10-K2

TECHNICAL MANUAL

Pneumatic Type Two Stage Clamp



FOR SAFE USE

Before the installation, operation, and inspection for this product, read the “FOR SAFE USE” and the technical manuals carefully. Also read the other technical manuals, “Sewing Machine Head”, “Control Unit” and “Operation Panel” describing some instructions, which are not in this manual, and use the sewing machine properly.

SAFETY INDICATIONS

	<p>CAUTION</p> <p>Indicates that incorrect handling may cause hazardous conditions, resulting in medium or slight personal injury or physical damage. Note that CAUTION level may lead to a serious consequence according to the circumstances. Always follow the instructions of both levels because they are important to personal safety.</p>
---	---

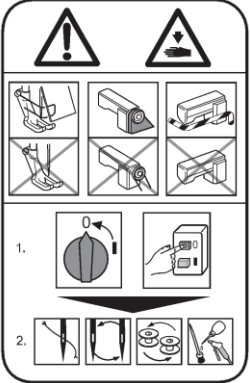
CAUTION INDICATIONS

No.	Caution indication	Description
1		<p><u>Precaution for sewing machine operation:</u></p> <p>Indicates that removing the safety and operating the sewing machine for some other purposes with power-on are prohibited.</p> <ul style="list-style-type: none"> ● Please do not operate the sewing machine without protective equipment such as a needle guard, an eye guard, a belt cover or the others. ● Please turn off the power switch when threading, changing a needle and a bobbin, cleaning, and lubricating.
2		<p><u>Caution for fingers injury:</u></p> <p>Indicates a possibility of fingers (hands) injury in a certain condition.</p>
3		<p><u>Caution for squeezing fingers:</u></p> <p>Indicates a possibility of squeezing fingers in a certain condition.</p>

1. Features

The pneumatic type (left/right alternating) two-stage clamp separates the pressing operation into the left and right sides. As each side can be operated with individual foot switches, this is suitable for stitching two parts together. Usage methods can be changed to suit the purpose and make setup of the stitching material more efficient. These methods include setting the left/right clamp operation order or canceling the operation order and pressing with the side for which the foot switch is ON.

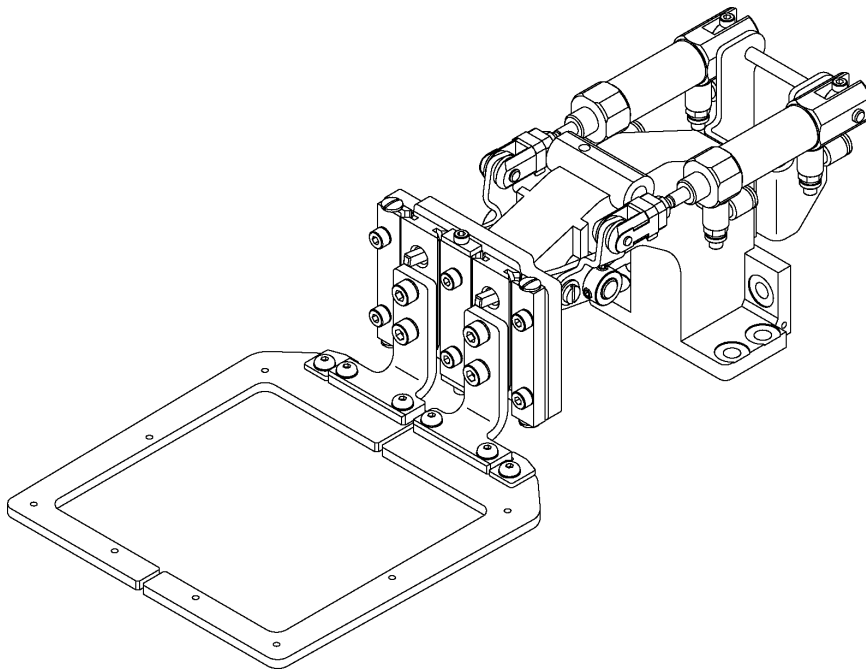

2. Specifications

Name	: MP-G10-K2 (pneumatic type two stage clamp)	
Applicable model:	: PLK-G1010	
Sewing area	: 100 (X) mm X 100 (Y) mm (same as PLK-1010)	
Clamp UP position	: 30 mm	
Pressing operation	: Use foot switch (2-pedal) normally provided with the industrial sewing machine and expansion foot switch (1-pedal)	
Drive source air pressure	Primary side	: 0.5 MPa (5 kg/cm ²) or more
	Secondary side:	: 0.4 MPa (4 kg/cm ²)



CAUTION

Trouble such as operation errors could occur if the secondary pressure is set too high. Use within the range of 0.4 MPa (4 kg/cm²).

3. Configuration

★ The Fig. numbers in the drawing correspond to the part numbers given in the following explanations.

3.1 Clamp mechanism

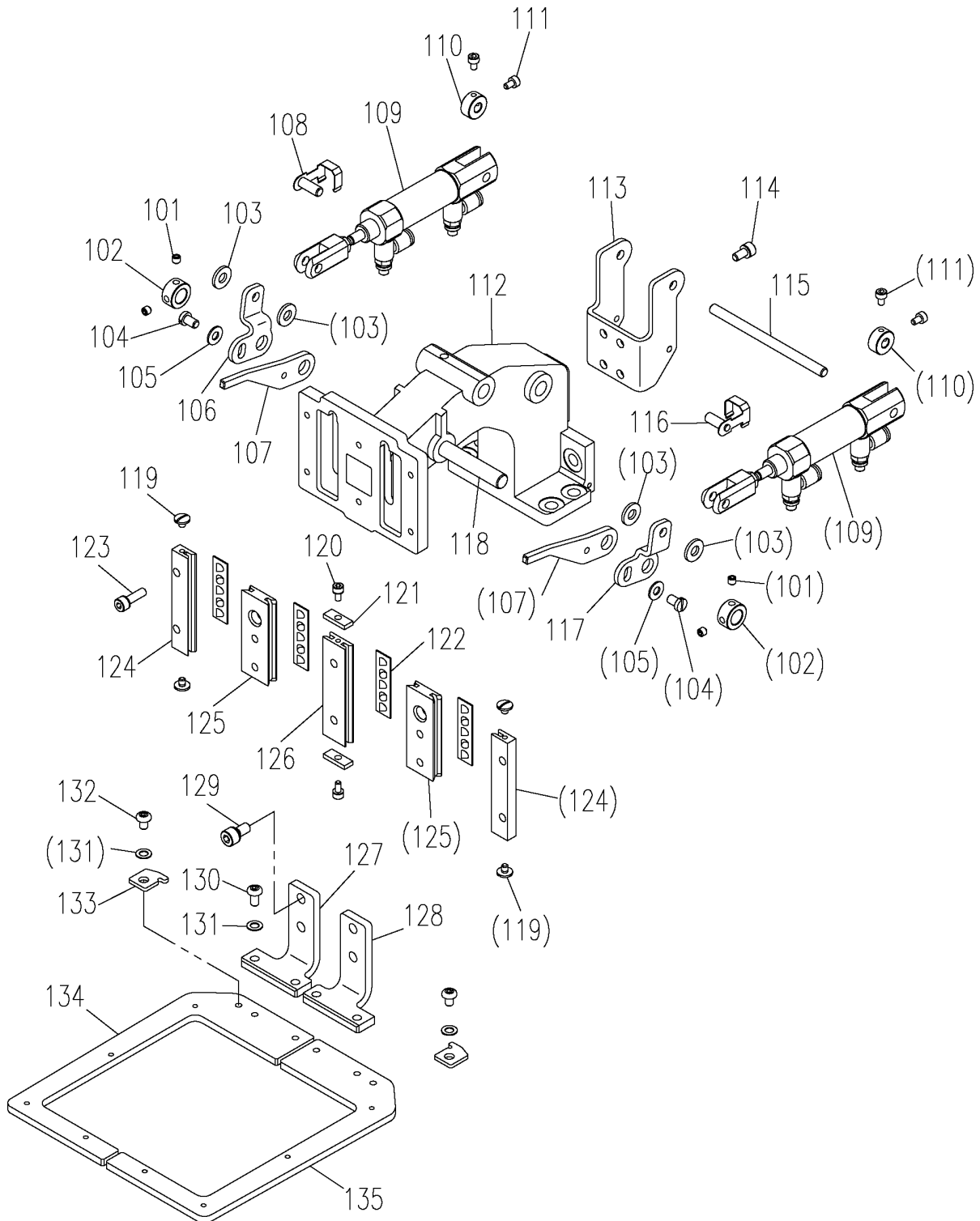

3.1 Clamp mechanism (Parts list)

Fig No.	部品コード Parts No.	品名	Description	数量 Amt. Req.
101	M91055020	ロッカクアナツキトメネジ M4X4	Screw M4X4	4
102	MH10A0352	カラー	Collar	2
103	M90519050	ナイロンワッシャ	Nylon washer	4
104	M91109002	ヒラネジ 11/64(40)X7	Screw 11/64(40)X7	2
105	M90421050	ザガネ 4	Washer 4	2
106	MH10K0950	レバー(S2L)	Lever (S2L)	1
107	MH10K1950	レバー(S1)	Lever (S1)	2
108	M90538060	ナックルピン(L)	Knuckle pin (L)	1
109	ME10P0434	エアシリンダ	Air cylinder	2
110	ME10P0352	カラー	Collar	2
111	M93025021	ロッカクアナツキホルト M3X5	Socket bolt M3X5	4
112	MH10A0308	オサエダイ	Clamp bracket	1
113	MH10K0601	シリンダトリツケイタ	Cylinder bracket	1
114	M94031017	セフティソケット M4X8	Safety socket bolt M4X8	4
115	M90555060	ピン	Pin	1
116	M90548060	ナックルピン(R)	Knuckle pin (R)	1
117	MH10K2950	レバー(S2R)	Lever (S2R)	1
118	M90822060	ピン	Pin	1
119	M90804003	マルヒラネジ 1/8(44)X4	Screw 1/8(44)X4	4
120	M93001017	セフティソケット M3X6	Safety socket bolt M3X6	2
121	MH10A4477	ストップ	Stopper	2
122	M94008070	ローラリテーナ	Roller retainer	4
123	M94034017	セフティソケット M4X14	Safety socket bolt M4X14	6
124	MH10A2957	オサエコテイレース	Fixed race	2
125	MH10A3957	オサエイドウレース	Movable race	2
126	MH10A4957	オサエコテイレース	Fixed race	1
127	MH10K0308	オサエトリツケイタ(L)	Clamp foot (L)	1
128	MH10K1308	オサエトリツケイタ(R)	Clamp foot (R)	1
129	M95018017	セフティソケット M5X10	Safety socket bolt M5X10	4
130	M94005022	ロッカクアナツキホタンホルト M4X8	Bolt M4X8	4
131	M90462050	コザガネ 4	Washer 4	6
132	M94041021	ロッカクアナツキホタンホルト M4X6	Bolt M4X6	2
133	MH10A0196	イチキメイタ	Guide plate	2
134	MH10K0105	オサエ(L)	Clamp frame (L)	1
135	MH10K1105	オサエ(R)	Clamp frame (R)	1

3.2 Pneumatic pressure control unit

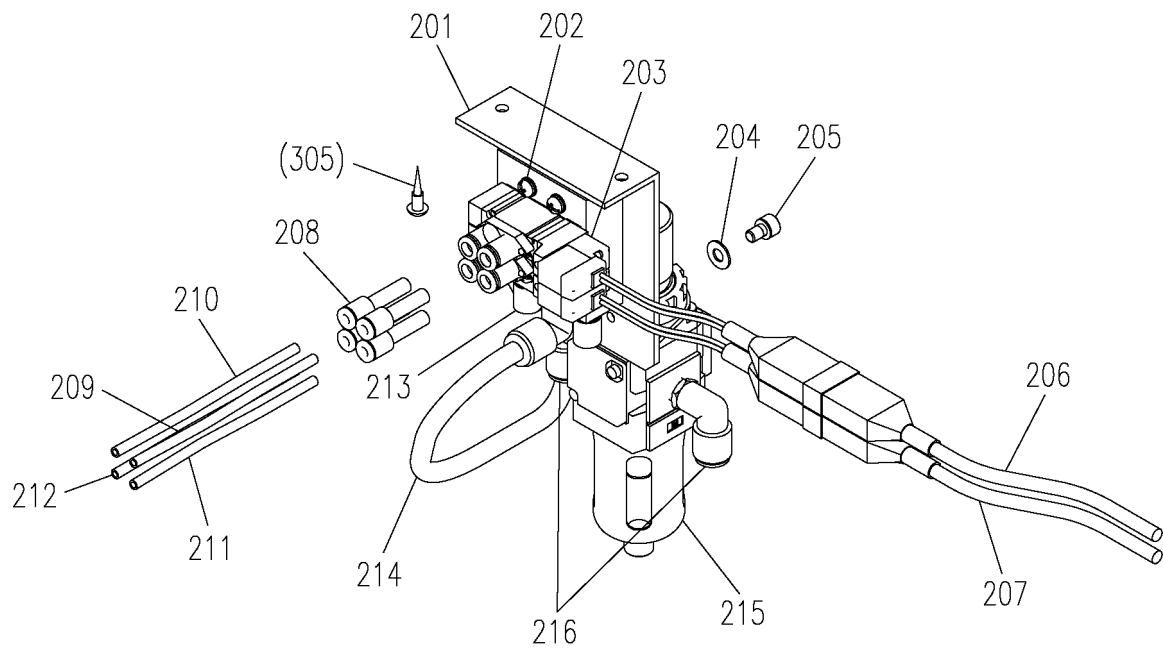

3.3 Accessories

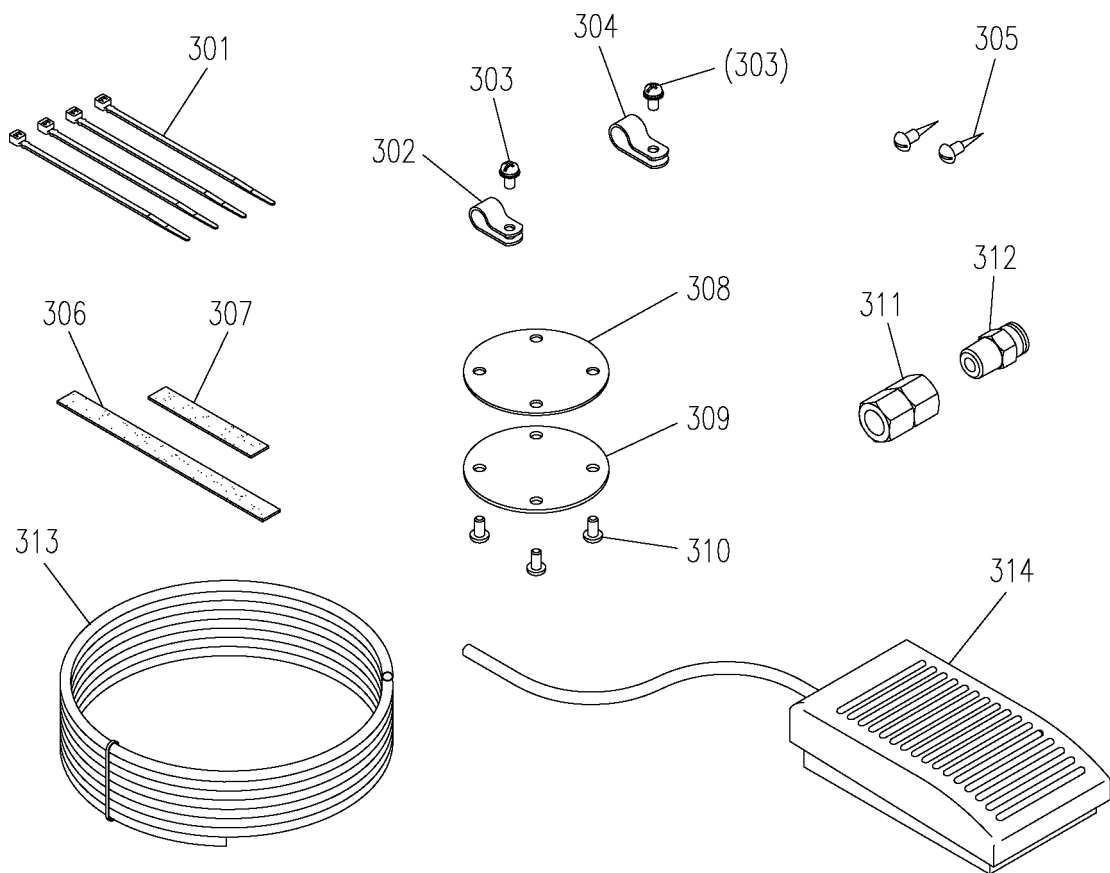

3.2 Pneumatic pressure control unit (Parts list)

Fig No.	部品コード Parts No.	品名	Description	数量 Amt. Req.
201	MB61A5601	テンジベントリツケイタ	Valve mounting plate	1
202	M91066004	SW-PW プラマイナヘネジ M4X25	Screw M4X25	4
203	MB10S0599	テンジベソクミタテ	Solenoid valve assy	1
204	M90518050	ザガネ 5	Washer 5	2
205	M95017017	セフテソケット M5X8	Safety socket bolt M5X8	2
206	MB10B0508	セツゾクテンセンクミタテ(A)	Cable assy (A)	1
207	MH10K0508	セツゾクテンセンクミタテ(B)	Cable assy (B)	1
208	MA30A0964	レジューサ	Reducer	4
209	MB10K0567	エアチューブクミタテ(A)	Air tube assy (A)	1
210	MB10K1567	エアチューブクミタテ(B)	Air tube assy (B)	1
211	MB10K2567	エアチューブクミタテ(C)	Air tube assy (C)	1
212	MB10K3567	エアチューブクミタテ(D)	Air tube assy (D)	1
213	M91035089	サイレンサ	Muffler	2
214	MB20P1567	エアチューブ	Air tube	1
215	ME40A0963	フィルタレギュレータ	Filter regulator	1
216	MA20A8571	L ガタワンタッチツギテ	L-type quick joint	3

3.3 Accessories (Parts list)

Fig No.	部品コード Parts No.	品名	Description	数量 Amt. Req.
301	MF06A1620	ケツゾクバンド	Cable tie	4
302	M94007099	ナイロンクリップ 6	Nylon clip 6	1
303	M91054004	SW-PW プラマイナヘネジ M4X8	Screw M4X8	2
304	MB60A1620	ナイロンクリップ 8	Nylon clip 8	1
305	M90409041	マルモクネジ 4.5X20	Wooden screw 4.5X20	2
306	MH10K0691	パッキン	Clamp pad	2
307	MH10K1691	パッキン	Clamp pad	4
308	ME10P0691	パッキン	Pad	1
309	MB10X0742	フタ	Cap	1
310	M94052021	ロッカクアナツキホルト M4X8	Bolt M4X8	4
311	M91010089	ロッカクソケット	Socket	1
312	MA30A0571	ワンタッチツギテ	Quick joint	1
313	MS06A0567	エアチューブ	Air tube	1
314	MH10K0FSW	フットスイッチ	Foot switch	1

4. Setup procedures



CAUTION

Always make sure that the power is OFF before starting setting work.

4.1 Installing the clamp drive mechanism

- (1) Remove the four screws on the Y axis movement race side fixing the clamp base (Fig.No.112) and the two screws on the axis support side, and remove the magnetic clamp mechanism mounted as a standard on the sewing machine.
- (2) Using the screws removed above, install this pneumatic clamp mechanism following the above step in reverse. Make sure that the clamp is not inclined at this time.
- (3) If there is no need to reinstall the magnetic clamp mounted as a standard on the sewing machine after changing to the pneumatic type clamp, it is recommended to remove the drive mechanism parts in the sewing machine head.

To remove these parts, refer to the part catalog P-341 for the PLK-G1010 sewing machine unit, and remove the parts including Fig.No.H130 pin E, and Fig.No.H120 presser plate shown in the catalog. Use the parts Fig.No.308, 309, and 310 enclosed with this attachment as a cover.

4.2 Installing the pneumatic pressure control related parts

- (1) The regulator and solenoid valve assembly configured of Fig.No.201, etc., are fixed to the bottom of the sewing machine table with the enclosed Fig.No.305 wood screws (two screws).
- (2) Align the piping symbols of the Fig.No.209, 210, 211 and 212 air tubes ($\phi 4$) with ports A to D on the pneumatic two stage clamp's Fig.No.109 air cylinder, and insert the tubes.
- (3) Pass the air tubes through the notched section on the side of the sewing machine unit's motor cover, and lead the tubes to the bottom of the table from the square hole on the table.
- (4) Align the air tubes ($\phi 6$) led out above with the ports A to D of the solenoid valve installed in step (1), and insert the tubes.
- (5) Bind the air tubes appropriately with the enclosed Fig.No.301 Cable ties.

4.3 Connecting the switches and cables

- (1) Remove the cover for the connector panel on the back of the sewing machine.
- (2) Disconnect the cable connected to CON13 (FU) on the solenoid PCB. This cable is not used after this attachment is mounted. Fix it where it will not obstruct the other electric parts.
- (3) Lead out the Fig.No.206 and 207 cables connected to the solenoid valve from the slot on the back of the sewing machine table, pass through the cord bushing on the connector panel, and lead in to the solenoid PCB side.
- (4) Insert the Fig.No.206 cable connector to CON13 (FU) on the PCB from where the cable was disconnected above.
- (5) Insert the Fig.No.207 cable connector to CON15 (OP1) on the PCB.
- (6) Connect the Fig.No.314 foot switch (1-pedal) cable to the connector (12P) on the head of the sewing machine. The green lead wire is the grounding wire. Connect this wire to the sewing machine bed.
- (7) This completes the connection of the wiring. Check the connection with the following table, and then securely install the cover removed from the connector panel.

		Signal name	Connection	
Input	Existing FSW	Work holder input 1 (I2)	CON H - ③ on control unit (foot switch already connected)	Red
		0V	CON H - ⑥ on control unit (foot switch already connected)	White
	Fig.No.314	Work holder input 2 (I8)	Sewing machine head Connector (12P) - ①	White
		0V	Sewing machine head Connector (12P) - ②	Black
Output	Fig.No.206 Cable symbol A	+24V	Sewing machine head solenoid PCB CON13 (FU) - ②	White Solenoid valve
		Work holder output 1 (O4)	Sewing machine head solenoid PCB CON13 (FU) - ①	Black
	Fig.No.207 Cable symbol B	+24V	Sewing machine head solenoid PCB CON15 (OP1) - ③	White Solenoid valve
		Work holder output 2 (O5)	Sewing machine head solenoid PCB CON15 (OP1) - ①	Black







4.4 Installing the system software



CAUTION

If the sewing machine is operated with the magnetic clamp settings, faults could occur.
Always install the system software for the pneumatic type clamp.

(1) Installing the System Software

- ① While holding down the [F] key on the front panel of the control box, turn the machine power ON.
(Keep pushing [F] key until red LED on the front panel is turned on.)
- ② [Model and language set function] screen is displayed.
- ③ Press the  . Select the **English** on the language set function screen then, press the  .
- ④ Press the  . Select the **1010K2** on the model set function screen then, press the  .
- ⑤ Press the  to determine the settings.
- ⑥ After [INITIALIZES SET VALUE] message is displayed, press the  .

This completes installing the system software. Turn off the power switch once.

(2) Points changed in setting details







The settings will be changed as shown below when the above system software is installed.

Mode	Function name	Two Stage clamp	Factory setting	Remarks
Clamp	FN	2	1	Setting for valid number of clamp
Input/output setting	I8	IF2	NO	Setting for operating work holder input 2
Input/output setting	O4	66H	33	Set this when changing from the magnetic clamp to the pneumatic clamp.
Input/output setting	O5	66H	33	Set this when changing from the magnetic clamp to the pneumatic clamp.

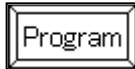
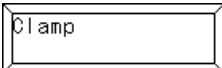
4.5 Setting the clamp priority order

As the default, the left/right work clamp is set to operate randomly when the foot switch is turned ON. To use this attachment so that the left clamp is lowered and then the right clamp is lowered, change the settings with the following procedures after installing the system software.

When this method is set, the operation will start with the left clamp, so turn the left clamp foot switch (2-pedal) [black] side ON. If the right clamp foot switch (1-pedal) is turned ON, neither the left nor right clamp will operate.

- (1) Press the  on the standard screen to open the MENU mode.
- (2) Press the  in the menu icon. The Program Mode [Mode Selection] screen is displayed.
- (3) Press the  .
- (4) The program Mode [Set Selection] is displayed.
- (5) Set the clamp priority order. Press the  [Priority of clamp mode].
- (6) Change the priority order invalid display  on the screen to valid  , and the press the  .
- (7) Press the  on the screen.
- (8) Then screen return to the [Mode Selection]. Press the  .

This completes the setting of the [clamp priority order].

5. Operation

5.1 Confirming operation

- (1) Turn the sewing machine power switch ON.
- (2) Confirm that the left and right work clamps lower when the foot switch (2-pedal) [Black] side and the expanded foot switch (1-pedal) are turned ON, and rise when the switches are turned ON again.
- (3) Lower the left and right work clamps, and press  on the operation panel. Return to home will start.
- (4) Next, check that the positional relation of the clamp and needle hole center is at the scale shown in the drawing. If the positions are deviated, refer to the PLK-G1010 Sewing Machine Head version instruction manual and adjust the home.

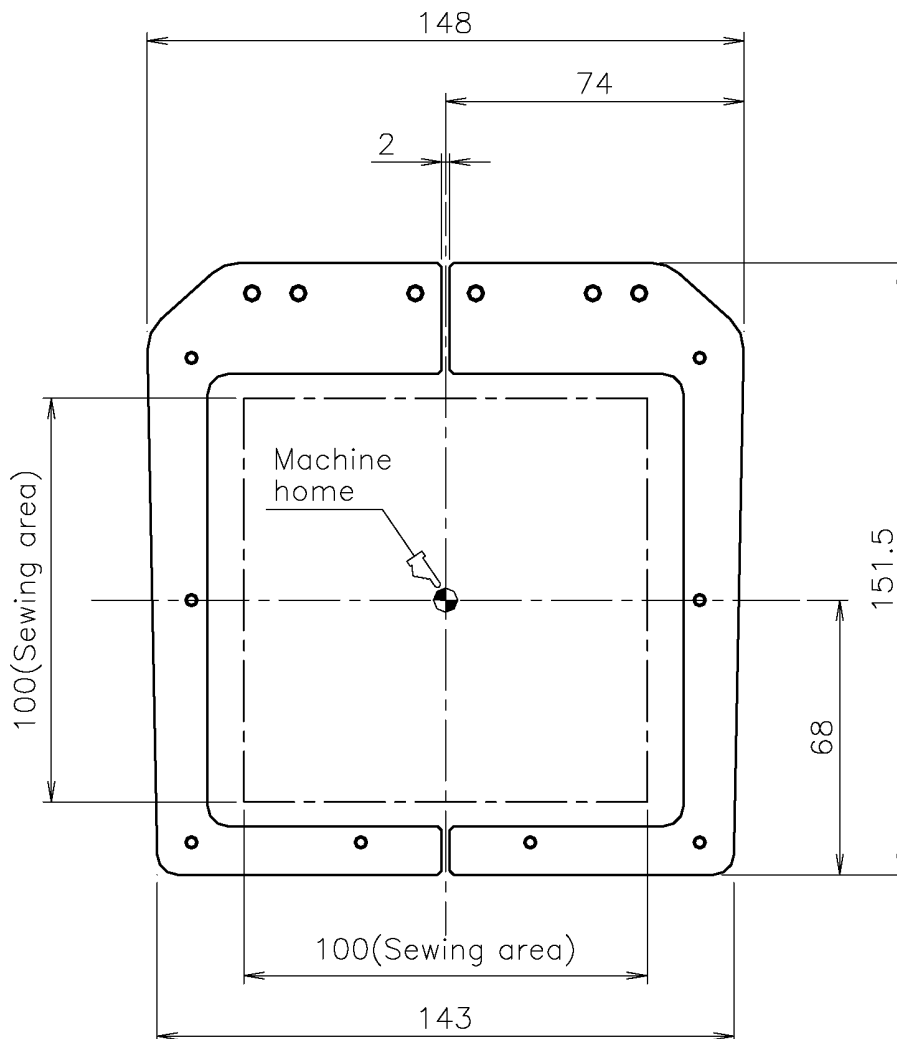

5.2 Stitching test

- (1) Select the stitching pattern. (Refer to the PLK-G1010 Sewing Machine Head version instruction manual.)
- (2) Press the [Black] side on the 2-pedal foot switch and the 1-pedal foot switch, and lower the left and right work clamps. Next, press the [Gray] side on the foot switch to rotate the sewing machine and start stitching. (Stitching will not start unless the left and right work clamps are lowered.)
- (3) When stitching is completed, the sewing machine will automatically return to home, and the clamps will rise.

MEMO

A large rectangular area with a solid border, containing 25 horizontal dashed lines for writing.

MEMO

A large rectangular area with a solid border, containing 25 horizontal dashed lines for writing.

JUKI CORPORATION

Printed in Japan