

JUKI®

INDUSTRIAL SEWING MACHINE
Attachment

MODEL

MP-G10-EX

TECHNICAL MANUAL

Extension Kit



FOR SAFE USE

Before the installation, operation, and inspection for this product, read the “FOR SAFE USE” and the technical manuals carefully. Also read the other technical manuals, “Sewing Machine Head”, “Control Unit” and “Operation Panel” describing some instructions, which are not in this manual, and use the sewing machine properly.

SAFETY INDICATIONS

	<p>CAUTION</p>	<p>Indicates that incorrect handling may cause hazardous conditions, resulting in medium or slight personal injury or physical damage. Note that CAUTION level may lead to a serious consequence according to the circumstances. Always follow the instructions of both levels because they are important to personal safety.</p>
---	-----------------------	---

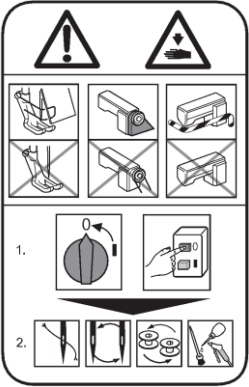
CAUTION INDICATIONS

No.	Caution indication	Description
1		<p><u>Precaution for sewing machine operation:</u></p> <p>Indicates that removing the safety and operating the sewing machine for some other purposes with power-on are prohibited.</p> <ul style="list-style-type: none"> ● Please do not operate the sewing machine without protective equipment such as a needle guard, an eye guard, a belt cover or the others. ● Please turn off the power switch when threading, changing a needle and a bobbin, cleaning, and lubricating.
2		<p><u>Caution for fingers injury:</u></p> <p>Indicates a possibility of fingers (hands) injury in a certain condition.</p>
3		<p><u>Caution for squeezing fingers:</u></p> <p>Indicates a possibility of squeezing fingers in a certain condition.</p>

1. Features

The extension kit is a dedicated part for the industrial sewing machine PLK-G1010 standard specifications, and is used to extend the sewing area in the X axis direction by 110mm. This kit is configured of the X axis table mechanism part, clamp mechanism part and parts for the sewing machine including the slide plate and reinforcement support parts, etc.

The pneumatic pressure control device for changing the magnetic type work clamp, mounted as a standard on the sewing machine, to the pneumatic type clamp is enclosed, so the force for clamping the material to be stitched can be increased, and the clamping speed can also be adjusted.

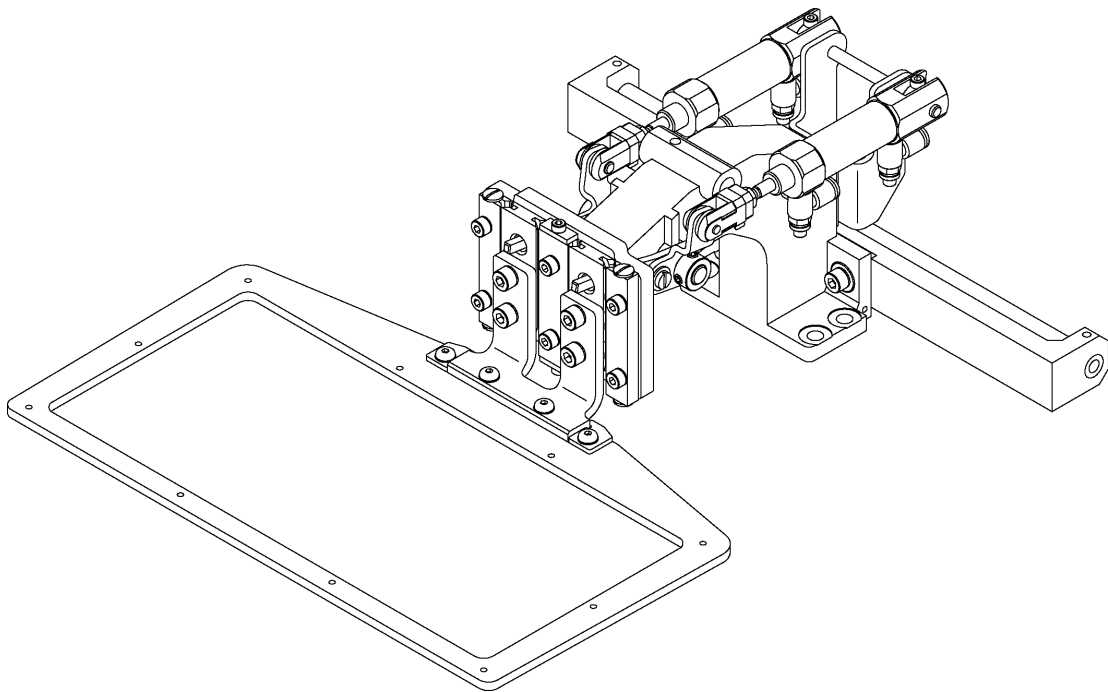

2. Specifications

Name		: MP-G10-EX (Extension Kit)
Applicable model:		: PLK-G1010
Sewing area		: 210 (X) mm X 100 (Y) mm
Clamp UP position		: 30 mm
Pressing operation		: Use foot switch normally provided with the industrial sewing machine
Drive source air pressure	Primary side	: 0.5 MPa (5 kgf /cm ²) or more
	Secondary side:	: 0.4 MPa (4 kgf /cm ²)



CAUTION

Trouble such as operation errors could occur if the secondary pressure is set too high.
Use within the range of 0.4 MPa (4 kgf /cm²).

3. Configuration

★ The Fig. numbers in the drawing correspond to the part numbers given in the following explanations.

3.1 Clamp mechanism

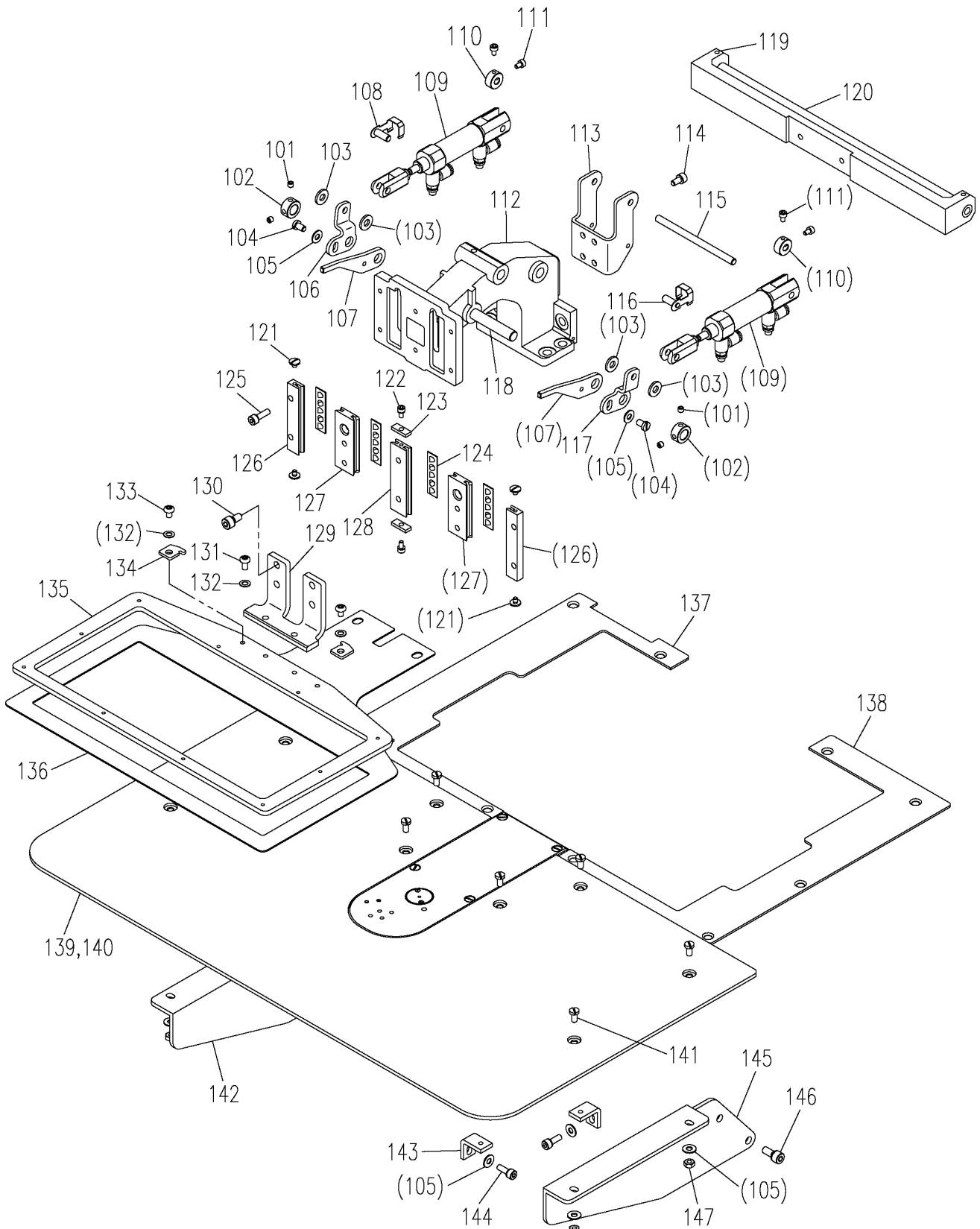

3.1 Clamp mechanism (Parts list)

Fig No.	部品コード Parts No.	品名	Description	数量 Amt. Req.
101	M91055020	ロックアナツキメネジ M4X4	Screw M4X4	4
102	MH10A0352	カラー	Collar	2
103	M90519050	ナイロンワッシャ	Nylon washer	4
104	M91109002	ヒラネジ 11/64(40)X7	Screw 11/64(40)X7	2
105	M90421050	ザガネ 4	Washer 4	10
106	MH10K0950	レバー(S2L)	Lever (S2L)	1
107	MH10K1950	レバー(S1)	Lever (S1)	2
108	M90538060	ナックルピン(L)	Knuckle pin (L)	1
109	ME10P0434	エアシリンダ	Air cylinder	2
110	ME10P0352	カラー	Collar	2
111	M93004021	ロックアナツキボルト M3X5	Socket bolt M3X5	4
112	MH10A0308	オサエダイ	Clamp bracket	1
113	MH10K0601	シリンダトリツケイタ	Cylinder bracket	1
114	M94002017	セフティソケット M4X8	Safety socket bolt M4X8	4
115	M90555060	ピン	Pin	1
116	M90548060	ナックルピン(R)	Knuckle pin (R)	1
117	MH10K2950	レバー(S2R)	Lever (S2R)	1
118	M90822060	ピン	Pin	1
119	MB10X0455	シクササエ	Shaft holder	1
120	MB10X0454	シク	Shaft	1
121	M90804003	マルヒラネジ 1/8(44)X4	Screw 1/8(44)X4	4
122	M94003017	セフティソケット M3X6	Safety socket bolt M3X6	2
123	MH10A4477	ストッパ	Stopper	2
124	M94008070	ローラリテーナ	Roller retainer	4
125	M94019017	セフティソケット M4X14	Safety socket bolt M4X14	6
126	MH10A2957	オサエコテイレース	Fixed race	2
127	MH10A3957	オサエイトウレース	Movable race	2
128	MH10A4957	オサエコテイレース	Fixed race	1
129	MH10A3601	オサエトリツケイタ	Clamp foot	1
130	M95005017	セフティソケット M5X10	Safety socket bolt M5X10	4
131	M94005022	ロックアナツキボルト M4X8	Bolt M4X8	2
132	M90422050	コザガネ 4	Washer 4	4
133	M94041021	ロックアナツキボルト M4X6	Bolt M4X6	2
134	MH10A0196	イチキメイタ	Guide plate	2
135	MH10X0105	オサエ	Clamp frame	1
136	MH10X0272	オクリイタ	Feed plate	1
137	MH10X0339	Xカバーイタ(L)	X-cover plate (left)	1
138	MH10X1339	Xカバーイタ(R)	X-cover plate (right)	1
139	MB10X2470	スベリイタ	Slide plate	1
140	MB10X0797	ホコフィルム	Film sheet	1
141	M90990002	ヒラネジ M4X8	Screw M4X8	8
142	MH10X0426	スベリイタササエ(L)	Slide plate bracket (L)	1
143	MB62A4601	トリツケイタ	Mounting plate	4
144	M94007017	セフティソケット M4X12	Safety socket bolt M4X12	4
145	MH10X1426	スベリイタササエ(R)	Slide plate bracket (R)	1
146	M95002017	セフティソケット M5X12	Safety socket bolt M5X12	4
147	M91004045	ナット M4	Nut M4	4

3.2 X-Y Table mechanism

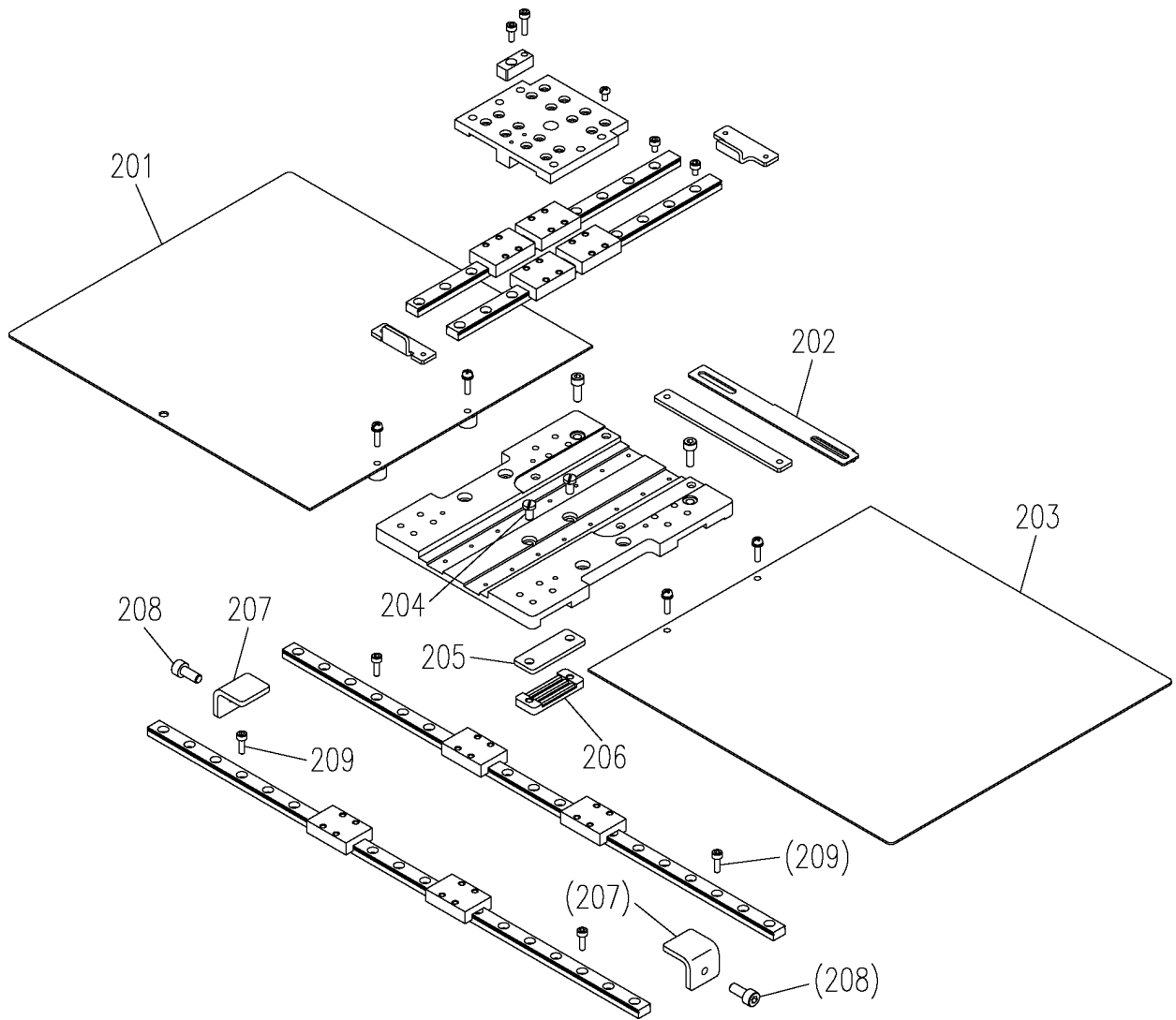

3.3 Pneumatic pressure control unit

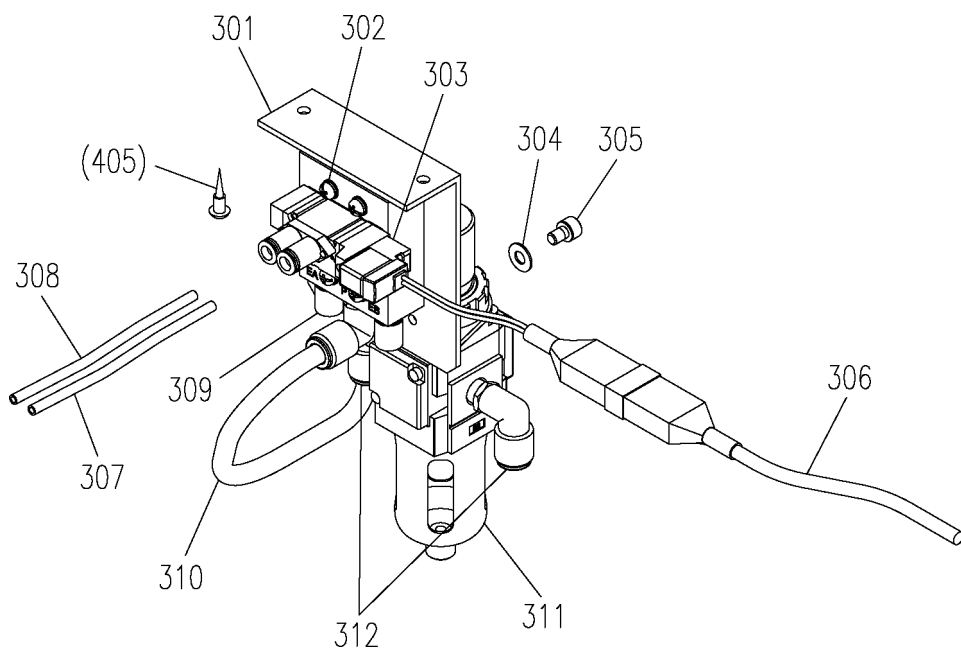

3.2 X-Y Table mechanism (Parts list)

Fig No.	部品コード Parts No.	品名	Description	数量 Amt. Req.
201	MH10X2339	X イドゥカバー(L)	Movable cover X (left)	1
202	MH10X0407	ケンシュツパン X	Detector plate X	1
203	MH10X3339	X イドゥカバー(R)	Movable cover X (right)	1
204	M90990002	ヒラネジ M4X8	Screw M4X8	2
205	MH10A1476	ベルトスペーサ X	Belt spacer X	1
206	MB60A0778	ベルトオサエ	Belt clamber	1
207	MH10X0477	X シックストップ	Stopper X	2
208	M95003021	ロッカアナツキボルト M5X12	Socket bolt M5X12	2
209	M95013021	ロッカアナツキボルト M3X10	Socket bolt M3X10	4

Note) Fig.No.205 and 206 Parts are not enclosed with this kit. Use the standard specification PLK-G1010 parts.

3.3 Pneumatic pressure control unit (Parts list)

Fig No.	部品コード Parts No.	品名	Description	数量 Amt. Req.
301	MB61A5601	テンジベントリツケイタ	Valve mounting plate	1
302	M91066004	SW-PW プラマイナベネジ M4X25	Screw M4X25	4
303	ME10X0599	テンジベソクミタテ	Solenoid valve assy	1
304	M90511050	ザガネ 5	Washer 5	2
305	M95003017	セフティソケット M5X8	Safety socket bolt M5X8	2
306	MB10B0508	セツゾクテンセンクミタテ	Cable assy	1
307	ME10X1567	エアチューブクミタテ(A)	Air tube assy (A)	1
308	ME10X0567	エアチューブクミタテ(B)	Air tube assy (B)	1
309	M91035089	サイレンサ	Muffler	2
310	MB20P1567	エアチューブ	Air tube	1
311	ME40A0963	フィルタレギュレータ	Filter regulator	1
312	MA20A8571	L ガタワンタッチツギテ	L-type quick joint	3

3.4 Accessories

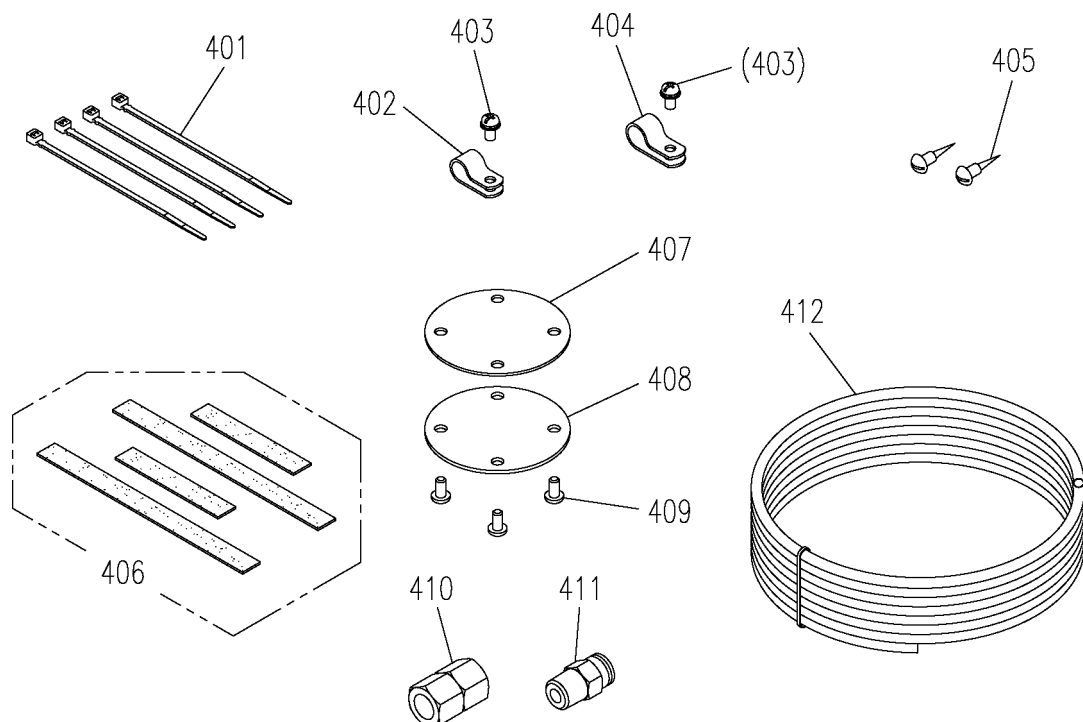

3.4 Accessories (Parts list)

Fig No.	部品コード Parts No.	品名	Description	数量 Amt. Req.
401	MF06A1620	ケツクバンド	Cable tie	4
402	M94007099	ナイロンクリップ 6	Nylon clip 6	1
403	M91054004	SW-PW フラマイナヘネジ M4X8	Screw M4X8	2
404	MB60A1620	ナイロンクリップ 8	Nylon clip 8	1
405	M90409041	マルモクネジ 4.5X20	Screw 4.5X20	2
406	MH10X0691	パッキンセット	Clamp pad set	1
407	ME10P0691	パッキン	Pad	1
408	MB10X0742	フタ	Cap	1
409	M95018021	ロックアナツキボルト M4X8	Bolt M4X8	4
410	M91010089	ロックソケット	Socket	1
411	MA30A0571	ワンタッチツギテ	Quick joint	1
412	MS06A0567	エアチューブ	Air tube	1

4. Setup procedures



CAUTION

Always make sure that the power is OFF before starting setting work.

4.1 Installing the clamp mechanism and X axis table mechanism

- (1) Remove the shaft (Fig.No.120) from the shaft holder (Fig.No.119) by loosening the set screw for the shaft holder coupling the Y drive shaft and clamp.
- (2) Uninstall the clamp mounted on the sewing machine as a standard by removing four screws on the movable race Y side fixing the clamp bracket (Fig.No.112).
- (3) Remove the movable covers X L/R (Fig.No.201, 203) on the X-Y table and also the X-cover plates L/R (Fig.No.137, 138).
- (4) Remove the standard stoppers X (Fig.No.207) then, install the Fig.No.207 stoppers X enclosed with this attachment with the Fig.No.208 socket bolts.
- (5) Insert the enclosed Fig.No.209 socket bolts to the screw hole fixing the standard stopper X (Fig.No.207). Do not use the screws removed in step (4). (The length is different)
- (6) Remove the standard detector plate X (Fig.No.202) then, install the Fig.No.202 detector plate X enclosed with this attachment.
- (7) Remove the left and right screws (Fig.No.204) coupling the cog belt X on the movable race X then, remove the belt spacer X (Fig.No.205) and the belt clasper (Fig.No.206).
- (8) Using the removed belt spacer X (Fig.No.205) and belt clasper (Fig.No.206), fix the cog belt X and movable race X with the enclosed Fig.No.204 screws at the center of the movable race X. Do not use the screws removed in step (7). (The length is different)
- (9) Assemble this attachment's clamp mechanism and the enclosed Fig.No.119 shaft holder using the screws for the removed clamp mechanism.
- (10) Attach the assembled clamp mechanism in step (9) in place of the removed clamp mechanism by the reverse procedure of step (2). Insert the Fig.No.120 shaft into the shaft holder, couple with linear bearing (ball bushing) for the Y drive shaft, and fix the shaft holder and shaft with the set screw.
- (11) Make sure that the clamp mechanism is not installed at an inclination. Move the clamp mechanism back and forth, left and right and make sure that it moves smoothly.
- (12) By the reverse procedure of step (3), install Fig.No.137, 138 X-cover plates L/R and Fig No.201, 203 movable covers X L/R.
- (13) If there is no need to reinstall the magnetic clamp mounted as a standard on the sewing machine after changing to this extension kit, it is recommended to remove the drive mechanism parts in the sewing machine head.

To remove these parts, refer to the part catalog P-341 for the PLK-G1010 sewing machine unit, and remove the parts including Fig.No.H130 pin E, and Fig.No.H136 clamp plate, etc. shown in the catalog. Use the parts Fig.No.407 and 408 enclosed with this attachment as a cover.



CAUTION

Hold the clamp mechanism to prevent it from dropping down and damaging the movable covers X when tilting the sewing machine.

4.2 Installing the slide plate

- (1) Refer to the part catalog P-341 for the PLK-G1010 sewing unit, and remove Fig No.B125 slide plate (outside), Fig.No.B118, B119, B120, and B129.
- (2) Temporary fix the enclosed Fig.No.142, 145, slide plate brackets L/R and Fig.No.143 mounting plate with the bolts Fig.No.144, 146, and etc., onto the sewing machine bed. Place the Fig.No.139 slide plate and fix with the Fig.No.141 screws. Then, adjust the slide plates (inside) and (outside) so that they are on the same plane, and fully tighten the slide plate brackets and mounting plate.
- (3) Align the enclosed Fig.No.140 film sheet with the needle hole position, and attach to the slide plate with double-faced adhesive tape, etc.

4.3 Installing the pneumatic pressure control related parts

- (1) The regulator and solenoid valve assembly configured of Fig.No.301, etc., are fixed to the bottom of the sewing machine table with the enclosed Fig.No.405 wood screws (two screws).
- (2) Align the piping symbols on the branched side ($\phi 4$) of the Fig.No.307 and 308 air tubes with ports A to D on the Fig.No.109 air cylinder, and insert the tubes.
- (3) Pass the air tubes through the notched section on the side of the sewing machine unit's motor cover, and lead the tubes to the bottom of the table from the square hole on the table.
- (4) Align the air tubes ($\phi 6$) led out above with the ports A and B of the solenoid valve installed in step (1), and insert the tubes.
- (5) Bind the air tubes appropriately with the enclosed Fig.No.401 Cable ties.

4.4 Installing the pneumatic pressure control related parts

- (1) Remove the cover for the connector panel on the back of the sewing machine.
- (2) Disconnect the cable connected to CON13 (FU) on the solenoid PCB. This cable is not used after this attachment is mounted. Fix it where it will not obstruct the other electric parts.
- (3) Lead out the Fig.No.306 cable connected to the solenoid valve from the slot on the back of the sewing machine table, pass through the cord bushing on the connector panel, and lead in to the solenoid PCB side.
- (4) Insert this Fig.No.306 cable connector to CON13 (FU) on the solenoid PCB from where the cable was disconnected above.
- (5) This complete the connection of the wiring. Check the connection with the following table, and then securely install the cover removed from the connector panel.

	Signal name	Connection	
Output	+24V	Sewing machine head solenoid PCB CON13 (FU) - ②	White
	Work holder output 1 (O4)	Sewing machine head solenoid PCB CON13 (FU) - ①	Black

4.5 Adjusting the home position

Due to the stitching area extension of the X axis direction, the X axis home position need to be changed.

- (1) The optimum range for moving the home position is shown as the shaded section.
- (2) Move the X side detector from the standard installation position to the right side looking from the front of the sewing machine. The positions A, B and C in the figure are the positons where the detector is installed.

- (3) When installing the detector at the position A, place it to the opposite direction to avoid stressing the detector code.
- (4) Refer to the PLK-G1010 Sewing Machine Head version instruction manual (7-21. Adjustment of the X-Y mechanical home position), and adjust the home position.

CAUTION

- The clamp mechanism and wiper could interfere depending on the home position.
- The detector cable could collide with the detector plate X, so fix it to the bed with a nylon clip.

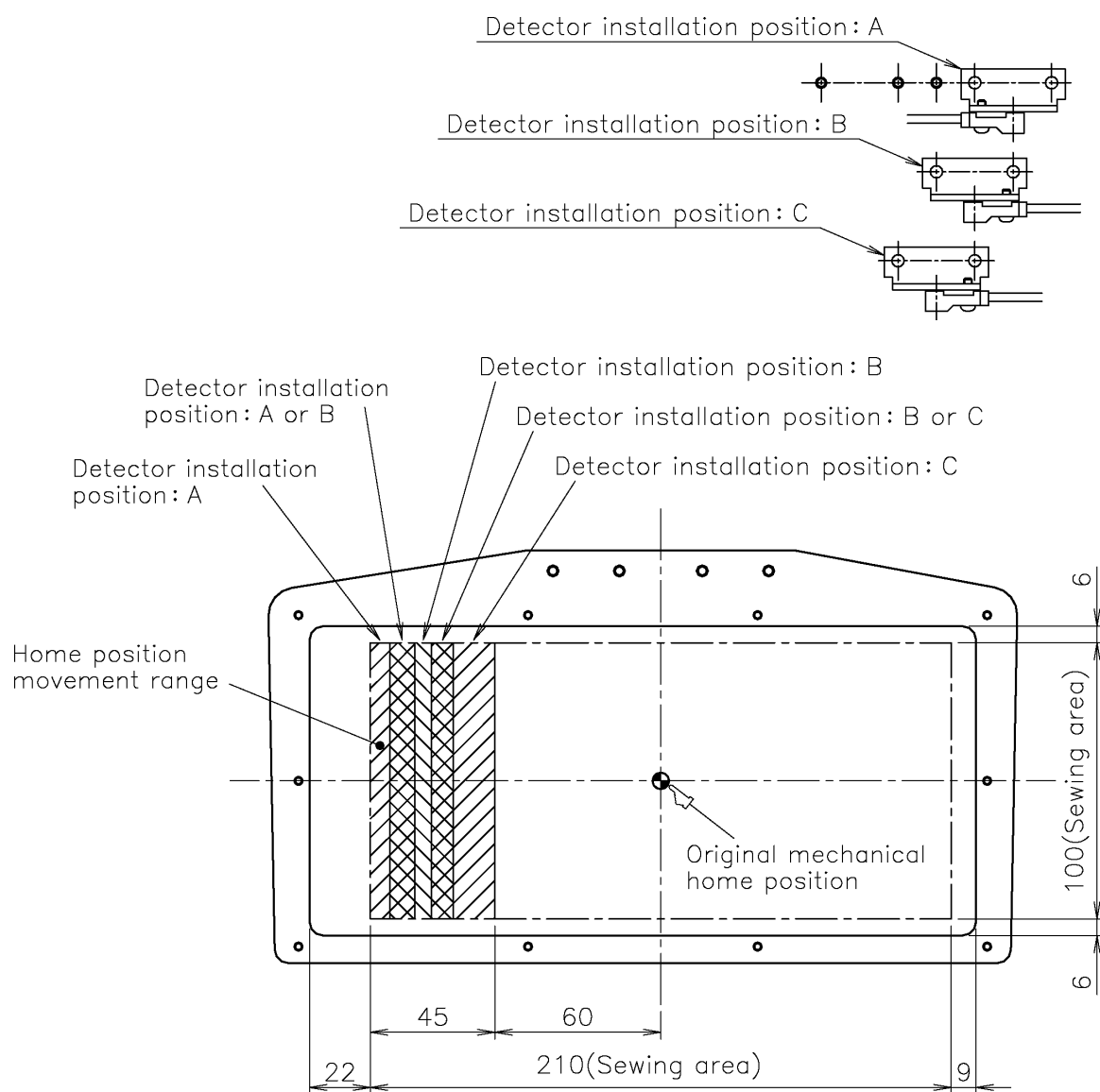

[Note] The shaded section below is the optimum range for moving the home position.







4.6 Installing the system software



CAUTION

If the sewing machine is operated with the magnetic clamp settings, faults could occur.
Always install the system software for the extension kit.

(1) Installing the System Software

- ① While holding down the [F] key on the front panel of the control box, turn the machine power ON.
(Keep pushing [F] key until red LED on the front panel is turned on.)
- ② [Model and language set function] screen is displayed.
- ③ Press the  . Select the **English** on the language set function screen then, press the  .
- ④ Press the  . Select the **1010EX** on the model set function screen then, press the  .
- ⑤ Press the  to determine the settings.
- ⑥ After [INITIALIZES SET VALUE] message is displayed, press the  .

This completes installing the system software. Turn off the power switch once.

(2) Points changed in setting details

The settings will be changed as shown below when the above system software is installed.

Mode	Function name	Extension kit	Factory setting	Remarks
Area limit	ALS	ON	OF	Area limit cancel ON/OFF
Feed method	FSL	7	8	Non stitch feed speed setting for long distance
Feed method	FSS	4	6	Non stitch feed speed setting for short distance
Speed	HIGH	2,200	2,800	High speed
Speed	MD1	1,500	2,000	Middle speed 1 [MD1]
Input/output setting	O4	66H	33	Set this when changing from the magnetic clamp to the pneumatic clamp.

5. Operation

5.1 Confirming operation

- (1) Turn the sewing machine power switch ON.
- (2) Confirm that the clamp lowers when the foot switch (2-pedal) [Black] side is turned ON, and rises when the switch is turned ON again. If the operation is reversed, check whether the piping connection is incorrect.
- (3) Lower the clamp, and press  on the operation panel. Return to home will start.

5.2 Stitching test

- (1) Select the stitching pattern. (Refer to the PLK-G1010 Sewing Machine Head version instruction manual.)
- (2) Press the [Black] side on the 2-pedal foot switch, and lower the clamp. Next, press the [Gray] side on the foot switch to rotate the sewing machine and start stitching.
- (3) When stitching is completed, the sewing machine will automatically return to home, and the clamp will rise.

JUKI CORPORATION

Printed in Japan