

TL-2020 PE ACCESSORY BOX INSTRUCTION MANUAL

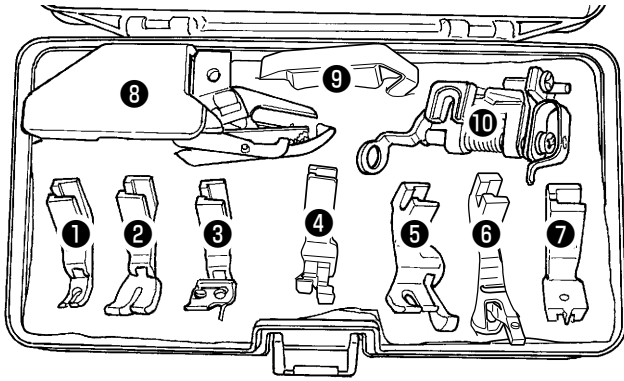

- ① Hinged Zipper Foot (2.5 mm)
- ② Smooth Foot
- ③ Spring Guide Hinged Foot (Right 1.5 mm)
- ④ Compensating Foot Extra Short (Right 1.5 mm)
- ⑤ Compensating Foot (Right 7 mm)
- ⑥ Hemming Foot
- ⑦ Invisible Zipper Foot (Plastic)
- ⑧ Even Feed Foot
- ⑨ Magnetic Gauge
- ⑩ 1/5" Quilting Foot

■ Changing the presser foot

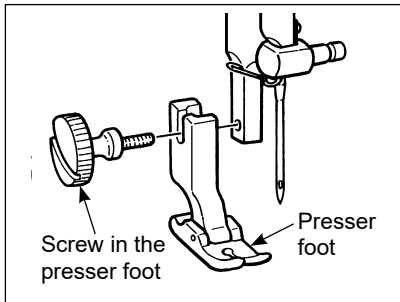

! CAUTION: Turn OFF the power switch when replacing the presser foot.

- 1 Turn off power and remove the presser foot.
- 2 Install the presser foot.

① Hinged Zipper Foot (2.5 mm)

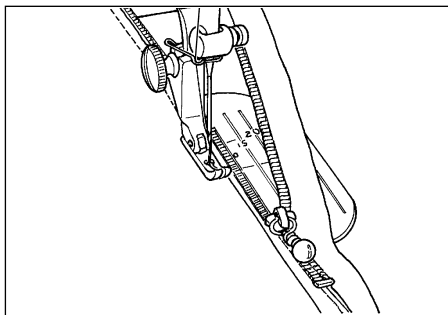

Narrow width of foot feeds zipper smoothly.

② Smooth Foot

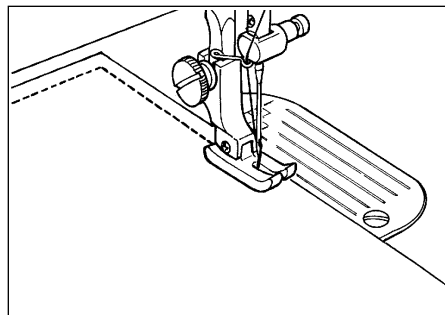

For hard-to-feed fabrics (vinyl cloth, leather).

③ Spring Guide Hinged Foot (Right 1.5 mm)

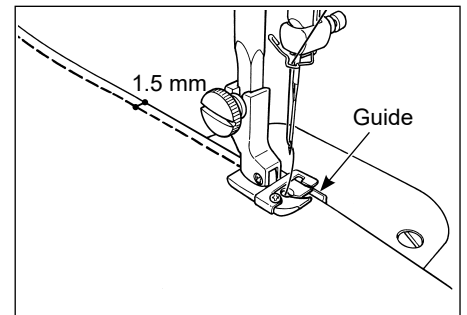

Sew the material while aligning its edge with the guide.
Stitches can be sewn at the position which is 1.5 mm away from the guide.

④ Compensating Foot Extra Short (Right 1.5 mm)

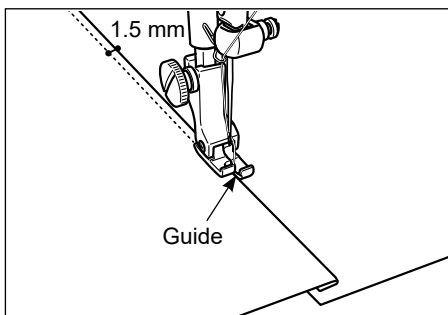

By guiding the fabric along the guide, stitching can be sewn 1.5 mm from the guide.
Its front part is shorter to sew small parts.

⑤ Compensating Foot (Right 7 mm)

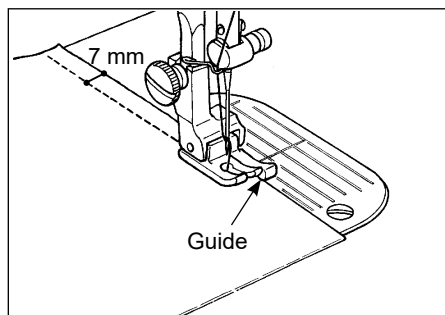

Sew the material while aligning its edge with the guide.
Stitches can be sewn at the position which is 7 mm away from the guide.

⑨ Magnetic Gauge

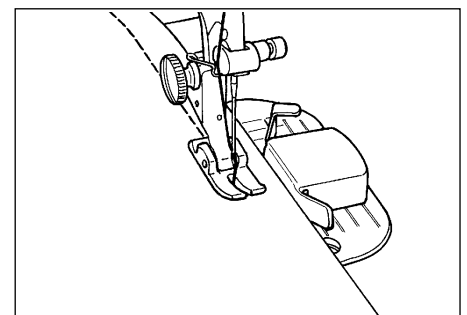

To guide edge of fabrics.

6 Hemming Foot

1 Cut the corner of the material.

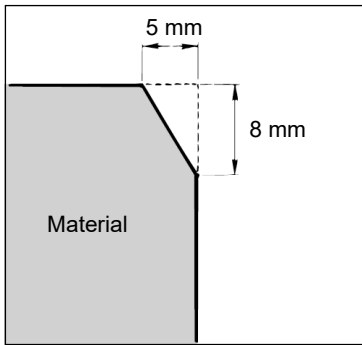

Trim the corner part of the material to help make the hemming foot hem the material edge.

2 Fit the trimmed material edge into the vortex groove in the hemming foot.

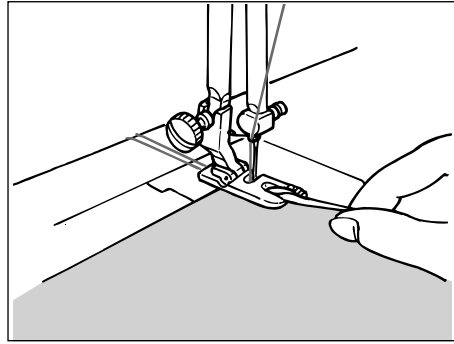

Fit the material into the vortex groove in the hemming foot until the descended needle reaches the material, and lower the hemming holder.

3 Hem the material edge while helping the material to go into the groove by hand.

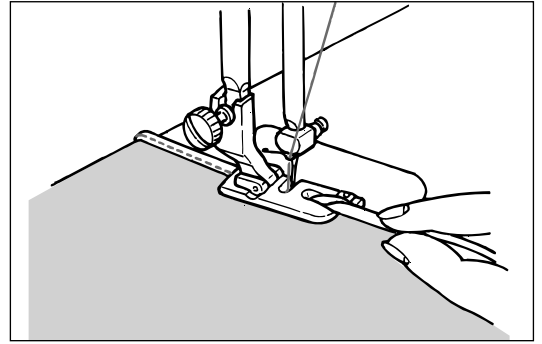

Draw the needle and bobbin thread ends with your left hand, turn the handwheel by 3 or 4 rotations until you are sure that the material edge is rolled into the groove.

Then hem the material edge while pinching the material edge with your right-hand thumb and index finger to make sure that the appropriate amount of material is fed into the hemming foot with consistency.

7 Invisible Zipper Foot (Plastic)

As a seam does not appear on the right side of the fabric, an opening can be finished with fabric edges neatly butted.

1 Check the zipper opening size. Install the standard presser foot (A).

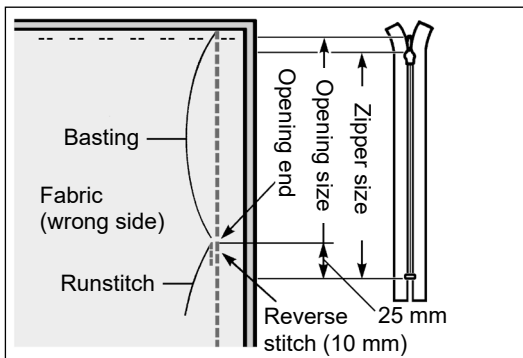

Place two pieces of fabric face to face. Baste the fabric from the edge of fabric to the opening end. At the opening end, change the stitch length to [2.0] and sew reverse stitches by 10 mm and sew until the predetermined position is reached. Neatly open the seam allowance.

2

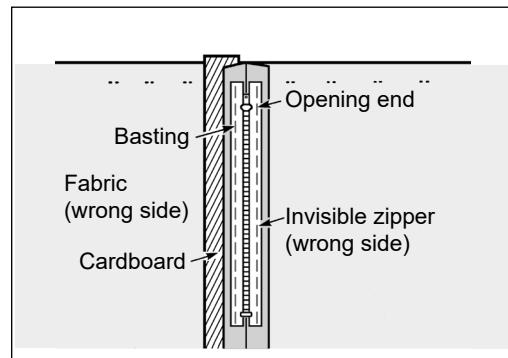

Put the invisible zipper on the fabric so that its center meets the seam line. Place a cardboard between the seam allowance and front fabric. Manually baste both sides of seam allowances and zipper tapes. Upon completion of basting, remove the cardboard.

3

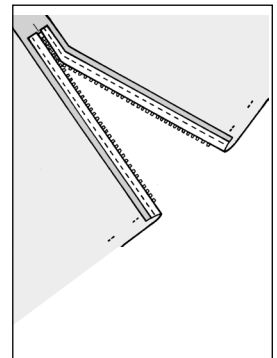

Undo the Basting stitch seam to the bottom of opening as shown in the sketch given in step 1. Then, open the zipper.

4

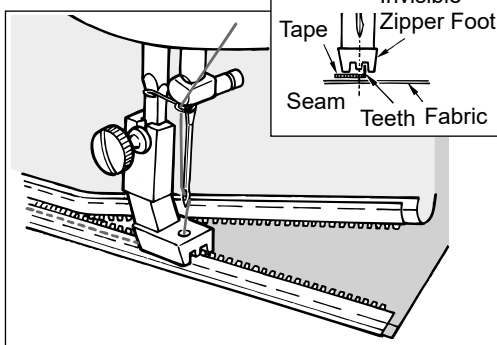

Aligning the teeth of either zipper tape with the groove on the zipper foot, sew the zipper at the very edge of the teeth from the end of opening while raising the teeth with fingers.

5

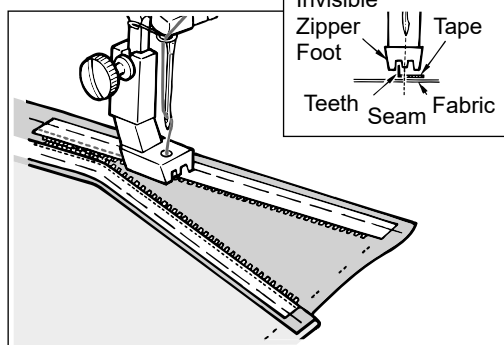

Sew the remaining zipper tape on the other side of seam allowance in the same procedure. (The lower portion of zipper tape located below the bottom of the opening will remain loose without sewn on the seam allowance.)

6

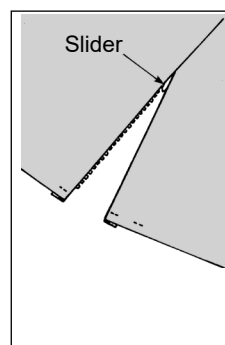

Take out the slider and pull it out to appear on the right side of the fabric.

8 Even Feed Foot

Generally, this presser foot is used for hard-to-feed or for difficult-to-feed materials such as velvet, jersey, vinyl, cloth artificial leather, leather, etc. This smoothly feeds the material and prevents the material from slipping.

1 Install the even feed foot.

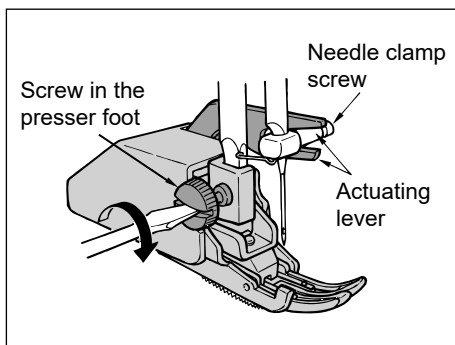

Fit forked portion of the actuating lever to the needle clamp, insert the installing portion into the presser bar, and securely tighten the screw in the presser foot.

2 Turn the presser foot pressure regulator to set the presser foot pressure to "low".

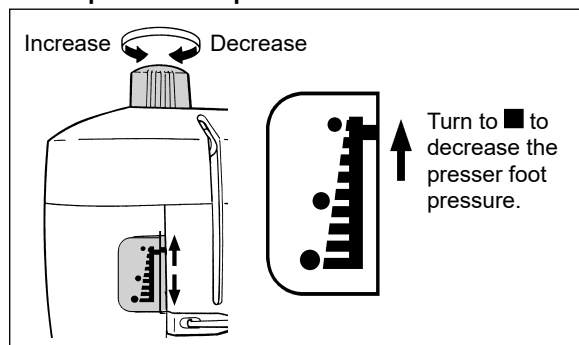

Set the pressure to "lowest" when sewing the velvet material. Use the sewing machine at medium speed.

10 1/5" Quilting Foot

This quilting foot is convenient for free motion quilting, quilting along with the pattern, free-hand embroidery, etc.

•1/5 inch = 5.0 mm type

This type is suited for free-motion quilting in general.

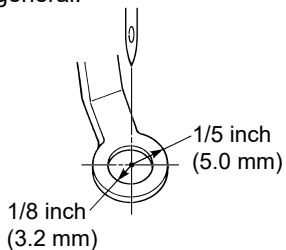

1 Install the quilting foot.

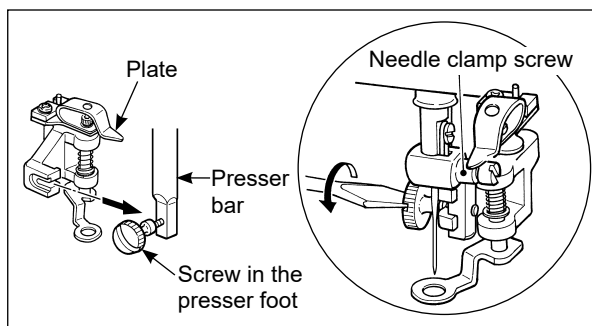

Put the plate on the needle clamp screw, insert the installing portion into the presser bar, and securely tighten the screw in the presser foot.

2 Position Feed Dog in lower position.

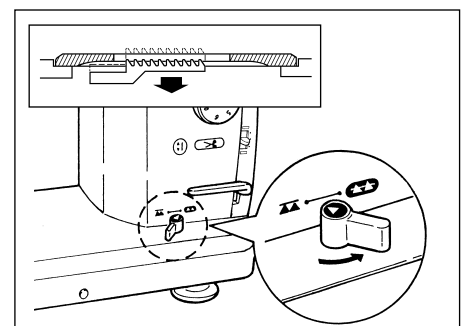

3 Position stitch length adjusting dial "0".

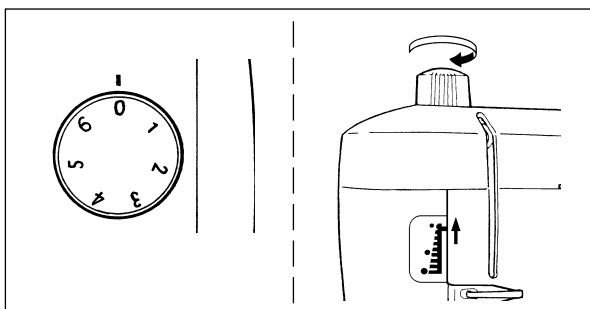

Rotate presser foot pressure regulator until blue bar in pressure indication window is at top.

4 Lower the foot and start sewing.

