

***ENGLISH***

**SC-920  
INSTRUCTION MANUAL**

# CONTENTS

<b>I. SPECIFICATIONS</b> .....	<b>1</b>
<b>II. SET-UP</b> .....	<b>1</b>
1. Changing over the voltage between 100 V and 200 V .....	2
2. Installing to the table.....	3
3. Installing the control panel.....	5
4. Connecting the cords.....	6
5. Attaching the connecting rod.....	12
6. Setting procedure of the machine head .....	13
7. Adjusting the machine head (direct-drive motor type sewing machine only) .....	14
<b>III. FOR THE OPERATOR</b> .....	<b>15</b>
1. Operating procedure of the sewing machine.....	15
2. Operation panel (CP-18).....	17
3. Operating procedure of the sewing pattern .....	18
(1) Reverse feed stitching pattern.....	18
(2) Overlapped stitching pattern .....	19
4. One-touch setting .....	20
5. Production support function .....	21
6. Setting of functions of SC-920 .....	24
7. Function setting list.....	25
8. Detailed explanation of selection of functions .....	29
9. Automatic compensation of neutral point of the pedal sensor.....	39
10. Selection of the pedal specifications.....	39
11. Setting of the auto lifter function .....	40
12. Selecting procedure of the key-lock function.....	41
13. Connection of the pedal of standing-work machine .....	41
14. External input / output connector .....	42
15. Connection of the material end sensor .....	43
16. Initialization of the setting data .....	44
<b>IV. MAINTENANCE</b> .....	<b>44</b>
1. Removing the rear cover.....	44
2. Replacing the fuse.....	45
(1) PWR PCB .....	45
(2) CTL PCB.....	46
3. Error codes.....	46

## I. SPECIFICATIONS

Supply voltage	Single phase 100 to 120V	3-phase 200 to 240V	Single phase 220 to 240V
Frequency	50Hz/60Hz	50Hz/60Hz	50Hz/60Hz
Operating environment	Temperature : 0 to 40°C Humidity : 90% or less	Temperature : 0 to 40°C Humidity : 90% or less	Temperature : 0 to 40°C Humidity : 90% or less
Input	320VA	320VA	320VA

\* The power consumption values shown in the above table are reference values in the case the main body of the sewing machine used with the SC-920 is DDL-9000B.

The power consumption differs with the machine head to be selected.

## II. SET-UP

SC-920 is a discrete control box and can be used with the DD (direct-drive) system sewing machine head.

To use a compact motor unit, the motor unit has to be installed on the table in prior to the installation of the control box on it. To connect the SC-920 to a compact motor, assemble them referring to "M92 SUPPLEMENTARY SETUP INSTRUCTIONS".

In the case the SC-920 is used for the DD (direct-drive) type sewing machine head, install the control box on the table following the instructions give below.

SC-920 control box

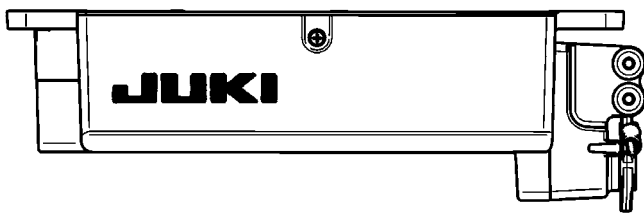

SC-920 control box (For installing the compact motor)

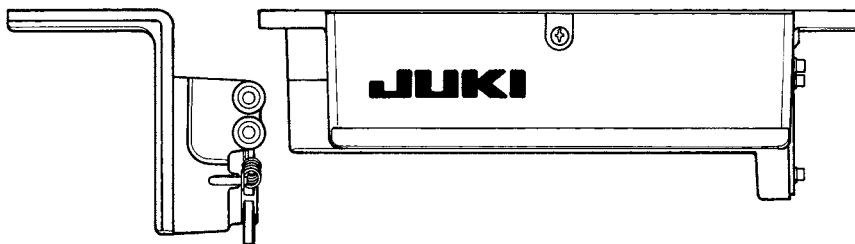

# 1. Changing over the voltage between 100 V and 200 V



## WARNING :

To prevent personal injuries caused by electric shock hazards or abrupt start of the sewing machine, carry out the work after turning OFF the power switch and a lapse of 5 minutes or more. To prevent accidents caused by unaccustomed work or electric shock, request the electric expert or engineer of our dealers when adjusting the electrical components.

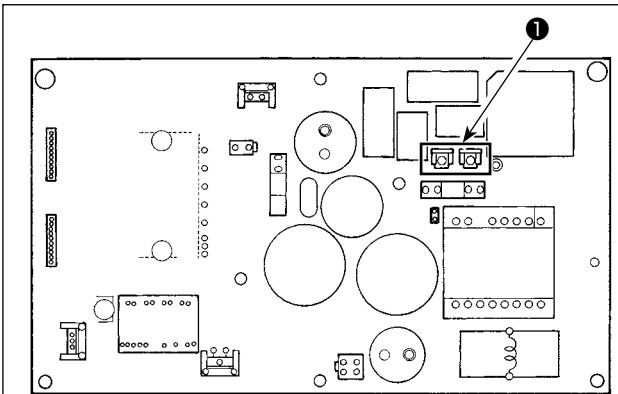

\* The illustration below shows the PWR-T PCB. The type of PCB differs by destination.

Depending on specifications of the control box, the number of phases and the voltage of the power supply can be changed over among "single-phase 100 - 120 V," "single-phase 200 - 240 V" and "3-phase 200 - 240 V."

- ① Replacement of the power cords
- ② Changing-round of connector ❶ on the PWR PCB
  - 1) Turn OFF the power with the power switch after checking that the sewing machine has stopped.
  - 2) Draw out the power cord from the power receptacle after checking that the power switch has been turned OFF. Then wait for 5 minutes or more.
  - 3) Loosen the screws which fix the cover of the control box. Open the cover in a slow manner.
  - 4) Changing procedure of the power voltage

**(Caution)** If the supply power changing is carried out in a wrong manner, the control box can break. Be extremely careful when taking the supply voltage changing procedure.

### A. To change over the supply voltage from 200 - 240 V to 100 - 120 V

- Change the power cord with the JUKI genuine cord with the part number (M90355800A0). Change the earth cord with the one with the part number (M90345800A0).
- Change over supply voltage changeover connector ❶ mounted on the PWR PCB with the connector for 100 V.
- Connect the crimp style terminal of AC input cord to the power plug as shown in the figure A.

### B,C. To change over the supply voltage from 100 - 120 V to 200 - 240 V

- Change the power cord with the JUKI genuine cord with the part number (M90175800A0).
- Change over supply voltage changeover connector ❶ mounted on the PWR PCB with the connector for 200 V.
- Connect the crimp contact of the AC input cord to the power plug as illustrated in Fig. B for the 3-phase power supply or as illustrated in Fig. C for the single-phase one.

- 5) Before closing the door, check to be sure again that the voltage has been changed without mistake.
- 6) Close the back lid and secure with the screws pressing the lid, while taking extra care to prevent the cord from being caught between the cover and the main body of the control box.

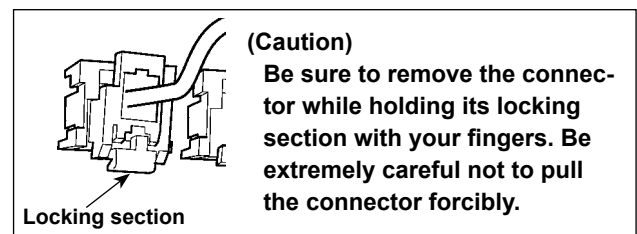
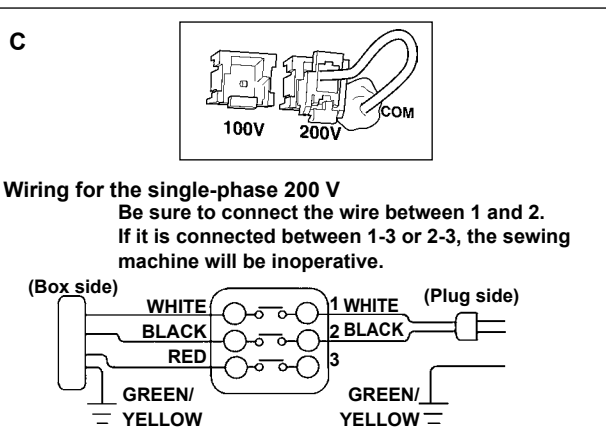
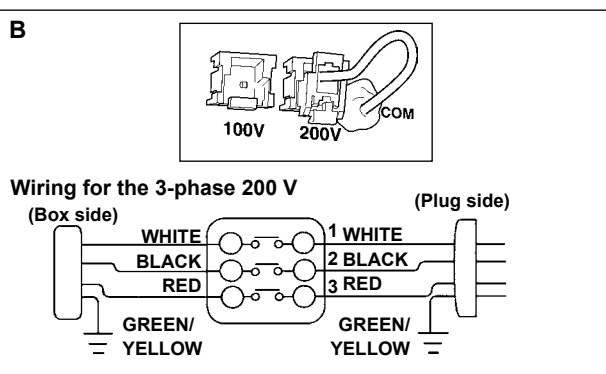
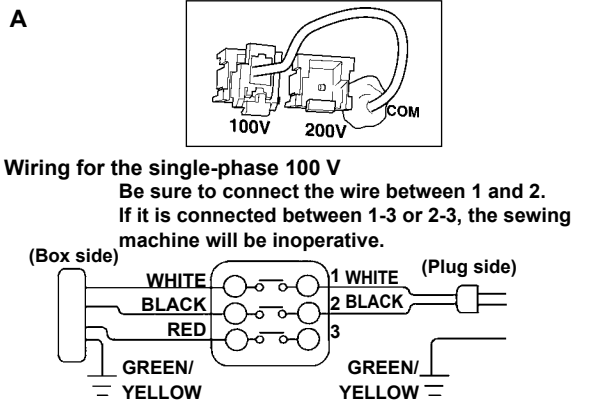

## 2. Installing to the table

In the case the SC-920 is used for the DD (direct-drive) type sewing machine head, install the control box on the table following the instructions give below.

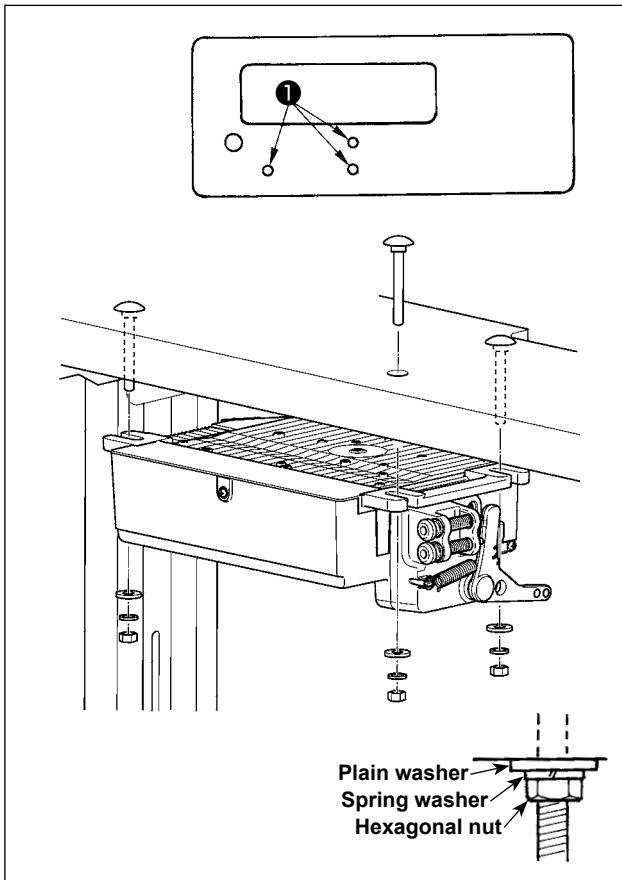

The description given below refers to the case the SC-920 is installed on the table of the DDL-9000B. To use any other machine head, install the control box on the table referring to the Instruction Manual for the main body of the relevant sewing machine.

- 1) Install the control box to the table with the fitting bolt (asm.) ❶ supplied with the unit as accessories. At this time, insert the nut and washer supplied with the unit as accessories as shown in the figure so that the control box is securely fixed.
- 2) After having installed the control box (and the compact motor) on the table, mount the sewing machine head on the table. (Refer to the Instruction Manual for the sewing machine to be used.)

[How to install the reactor box]



**WARNING :**

Be sure to install the reactor box after turning the power OFF.

\* For the EU-type models, install the reactor box that is supplied with the sewing machine.

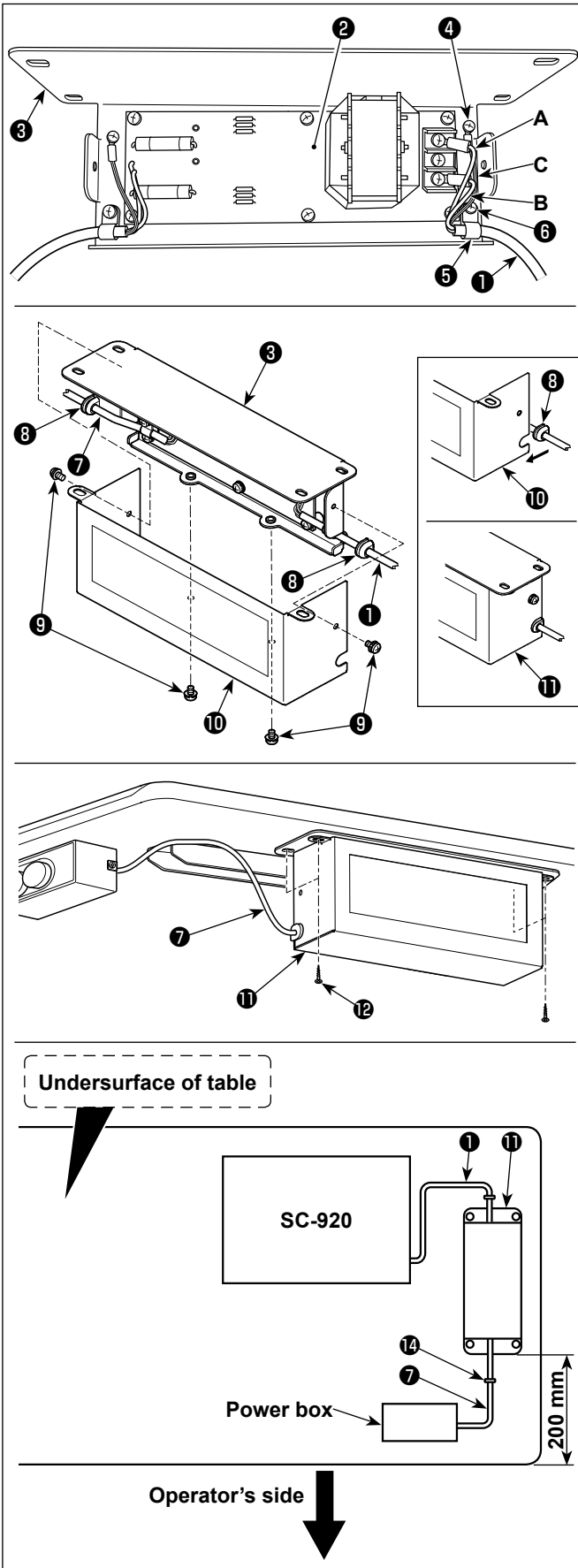

- 1) Connect the terminals of power cord ① of the SC-920 to reactor-box PCB asm. ② and to reactor box mounting plate ③ .  
Connect brown wire **A** to the first connector and blue wire **B** to the third connector respectively from the top of terminal block on the reactor box PCB asm. using screws. Connect green/yellow wire **C** to reactor box mounting plate ③ with earth setscrew ④ .
- 2) Attach cable clip ⑤ to the power cord of SC-920. Attach the power cord together with the cable clip to reactor box mounting plate ③ with cable clip setscrew ⑥ .
- 3) Attach cord bushes ⑧ to input/output cables ① and ⑦ of the reactor box.
- 4) Attach reactor box cover ⑩ to reactor box mounting plate ③ with four reactor-box cover setscrews ⑨ .  
At this time, fix cord bushes ⑧ attached to input/output cables ① and ⑦ in the concave section on reactor box cover ⑩ to eliminate a gap between reactor box ⑪ and cover ⑩ .
- 5) Install reactor box ⑪ on the table stand with four accessory wood screws ⑫ at the position that is approximately 200 mm away from the front end of table stand.  
Adjust the installing position according to the size of table stand so that the reactor box does not protrude from the edge of table stand.
- 6) Fix input/output cables ① and ⑦ of reactor box ⑪ on the table stand using accessory cord staple ⑭ .  
At this time, take care not to cross the input- and output-cables.

### 3. Installing the control panel



**WARNING :**

To protect against possible personal injury due to abrupt start of the machine, be sure to start the following work after turning the power off and a lapse of 5 minutes or more.

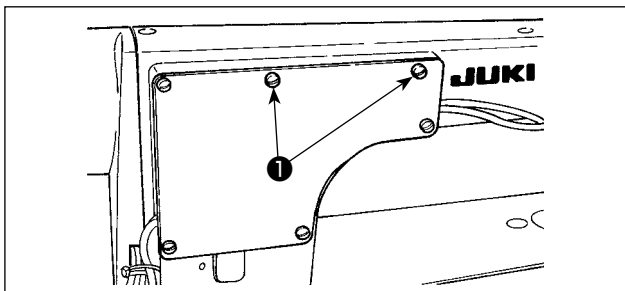

- 1) Remove side plate setscrews ① from the side plate.

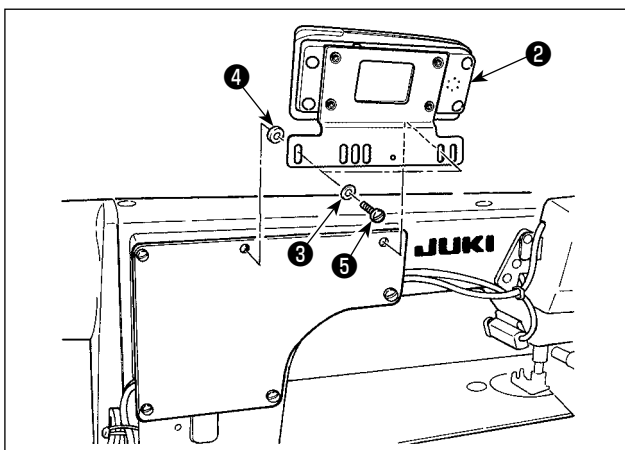

- 2) Install control panel ② on the machine head using screws ⑤, flat washers ③ and rubber seat ④ supplied with the control panel as the accessories.

- (Caution)**
1. DDL-9000B (Not provided with AK) is given as an example of installing procedure.
  2. Screw to install the panel changes according to the machine head used. Refer to Table 1 and confirm the kind of screw.

< The relation between the respective machine heads and the positions of installing hole of the bracket are as described in the table. >

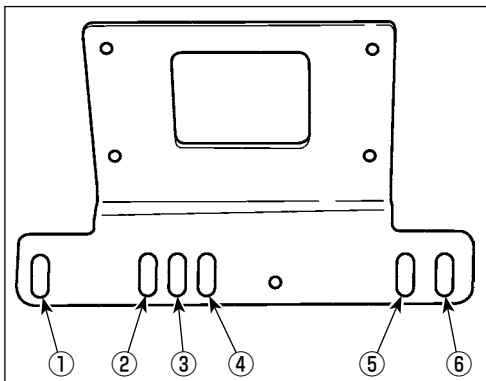

Table 1

	Installing hole	Screw	
DDL-9000B	① - ⑤	(Provided with AK) M5 X 14	Side plate setscrew
		(Not provided with AK) M5 X 12	
LH-3500A	② - ⑤	M5 X 14	Side plate setscrew
DLN-9010	② - ⑤	3/16-28 L=12	Screw supplied with panel as accessories
DDL-8700 series	③ - ⑤	3/16-28 L=12	Screw supplied with panel as accessories
DDL-5500 series *1	③ - ⑤	3/16-28 L=12	Screw supplied with panel as accessories
LZ-2280 series *1	③ - ⑤	11/64-40 L=7.8	Screws supplied with machine head

\*1 For the DDL-5556 and LZ-228\*, the machine head is supplied with an auxiliary bracket for mounting the control panel as an accessory. Be sure to install the bracket while referring to the instruction manual for the machine head.

- (Caution)**
1. Screws to be used for installing the panel differ with the machine head, i.e., screws supplied with the panel as accessories and the side plate setscrews. Select appropriate screws/setscrews referring to Table 1.
  2. If the screw type is not correct, the tapped hole can be collapsed.
  3. If you want to install the panel on the DDL-8700, be aware that the method to install it on the machine head differs depending on whether or not the machine head is provided with the AK device.
    - Machine head with the AK device:**  
Install the panel on the head bracket supplied with the AK. (The auxiliary bracket should be fixed with the side plate setscrews.)
    - Machine head without the AK device:**  
Remove the side plate setscrews and install the panel on the side plate using the screws supplied with panel as accessories.
  4. If you want to use the panel with the machine head for heavy-weight materials, install it referring to the "Supplementary Instructions" for the machine head.

## 4. Connecting the cords



### WARNING :

- To prevent personal injury caused by abrupt start of the sewing machine, carry out the work after turning OFF the power switch and a lapse of 5 minutes or more.
- To prevent damage of device caused by maloperation and wrong specifications, be sure to connect all the corresponding connectors to the specified places. (If any of the connectors is inserted into a wrong connector, not only the device corresponding to the connector can break but also it can start abruptly, inviting the risk of personal injury.)
- To prevent personal injury caused by maloperation, be sure to lock the connector with lock.
- As for the details of handling respective devices, read carefully the Instruction Manuals supplied with the devices before handling the devices.

The SC-920 is provided with the connectors listed below. Connect the sewing-machine connectors to the corresponding control-box connectors according to the devices installed on the sewing machine.

**(Caution)** For the SC-920 Series, the machine head to be used with is to be selected in the course of the function setting procedure. To prevent an insertion error, remove the resistor pack for the machine head selection before use.

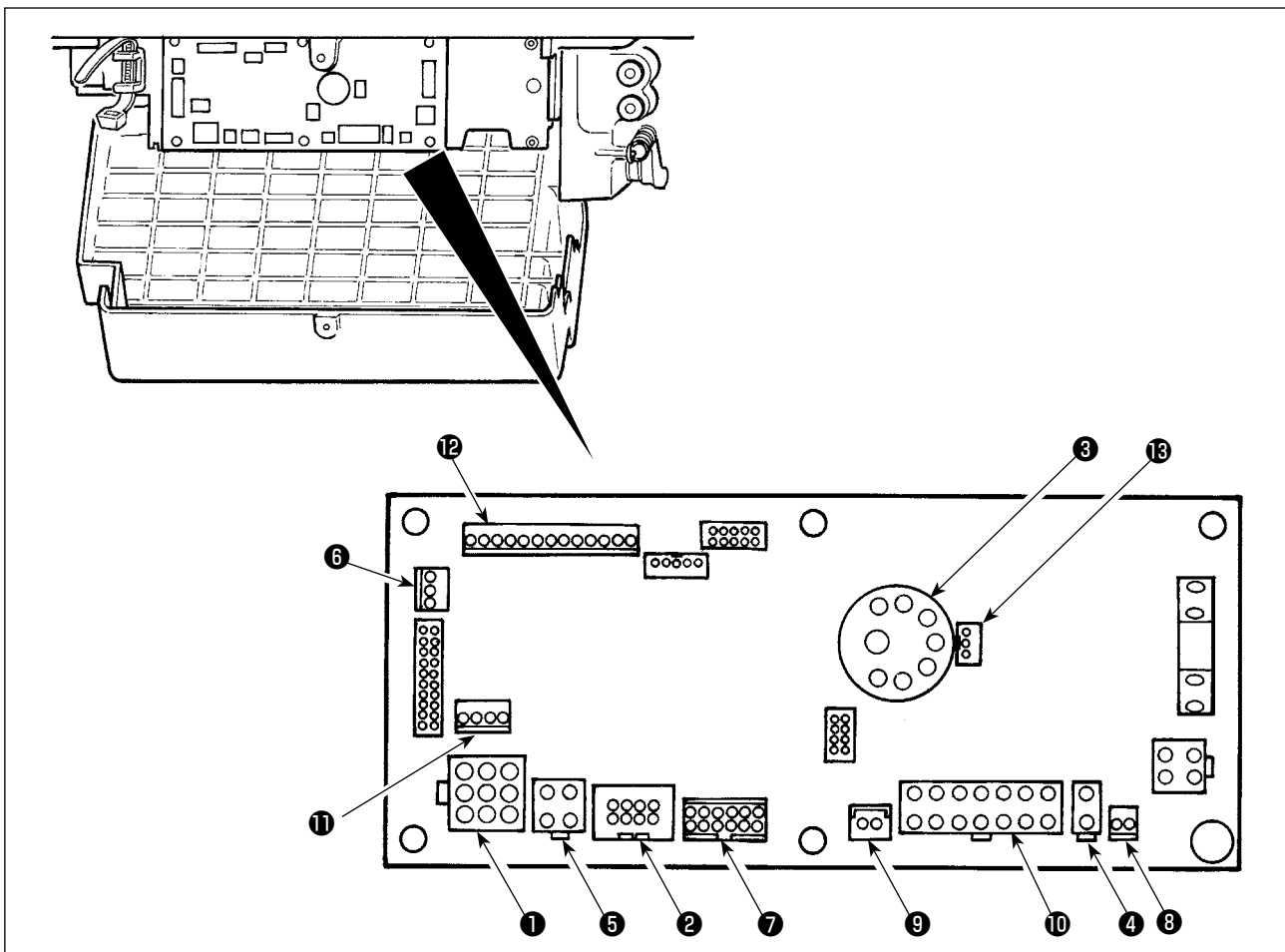

- |        |  |        |   |
|--------|--|--------|---|
| ① CN30 | Motor signal connector   | ⑥ CN42 | Thread trimming safety switch   |
| ② CN38 | Operation panel: Various kinds of sewing can be programmed. (For details of the operation panel other than CP-18, refer to the Instruction Manual for the panel to be used.) | ⑦ CN39 | Standing machine pedal : JUKI standard PK70, etc. Sewing machine can be controlled with external signals.                       |
| ③ CN33 | Synchronizer : It detects the needle bar position.   | ⑧ CN58 | +24 V external power source   |
| ④ CN37 | Presser foot lifting solenoid (Only for the automatic presser foot lifter type)  | ⑨ CN57 | Simplified production control counter input   |
| ⑤ CN48 | Safety switch (standard) : When tilting the sewing machine without turning the power OFF, the operation of the sewing machine is prohibited so as to protect against danger. | ⑩ CN36 | Machine head solenoid: Provided with solenoids for thread trimming, reverse feed stitching, one-touch type reverse feed switch. |
|        |  | ⑪ CN54 | Material end detection sensor, etc.   |
|        |  | ⑫ CN50 | Optional function/device input/output.  |
|        |  | ⑬ CN34 | Pedal sensor: The pedal sensor supplied with the SC-920 is to be connected to this connector to operate the sewing machine.     |



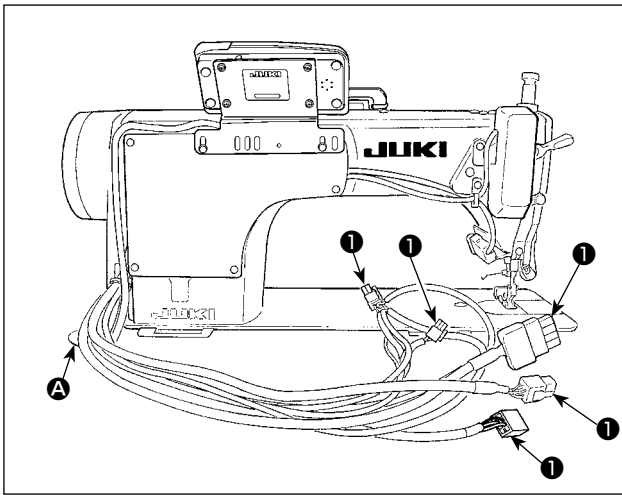

- 1) Pass cords ❶ of the thread trimming solenoid, reverse-stitching solenoid, etc. and the cord from the motor through hole ❸ in the table to route them down under the machine table.

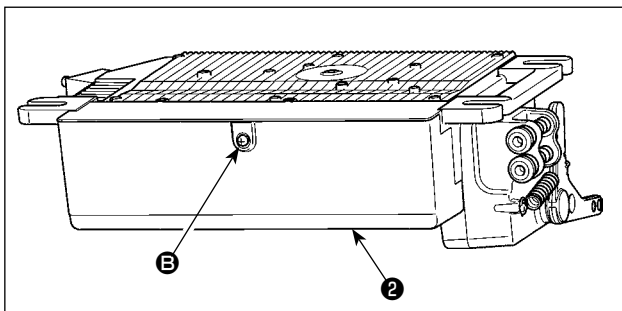

- 2) Loosen screw ❸ in cover ❷ with a screwdriver to open the cover.

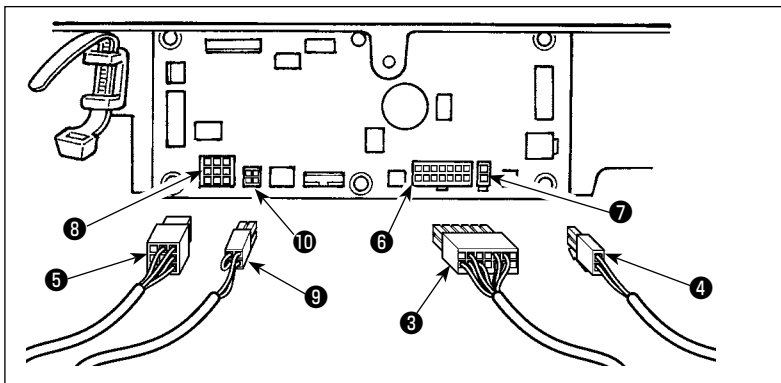

- 3) Connect 14P code ❸ coming from the machine head to connector ❹ (CN36).
- 4) When the optional AK device is attached, connect 2P connector ❺ coming from the AK device to connector ❻ (CN37).
- 5) Connect connector ❻ coming from the motor to connector ❸ (CN30) on the circuit board.
- 6) Insert 4P cord ❾ coming from the machine head into connector ❿ (CN48).

**(Caution) 1. When using the AK device, set whether to use the AK device after confirming how to select the auto-lifter function. (Refer to “III-11. Setting of the auto lifter function” p.40.)**

2. Be sure to securely insert the respective connectors after checking the inserting directions since all connectors have the inserting directions. (When using a type with lock, insert the connectors until they go to the lock.) The sewing machine is not actuated unless the connectors are inserted properly. In addition, not only the problem of error warning or the like occurs, but also the sewing machine and the control box are damaged.

**[Connecting the connector for the operation panel]**

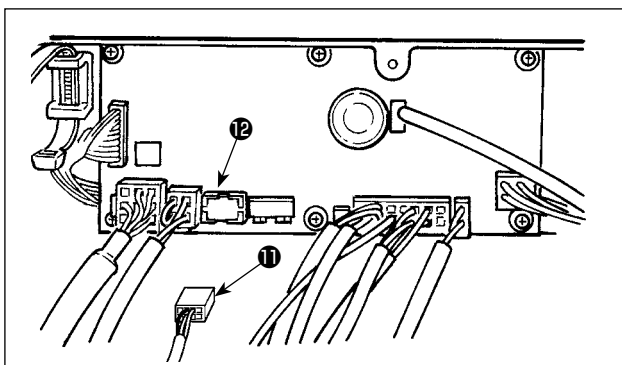

The SC-920 is provided with a connector for the operation panel. Fully insert connector ❶ into connector (CN38) ❷ on the PWB until it locks without fail while carefully checking the orientation of connector ❶.

**(Caution) Be sure to turn OFF the power before connecting the connector.**

[ Connection of the pedal of standing-work machine ]

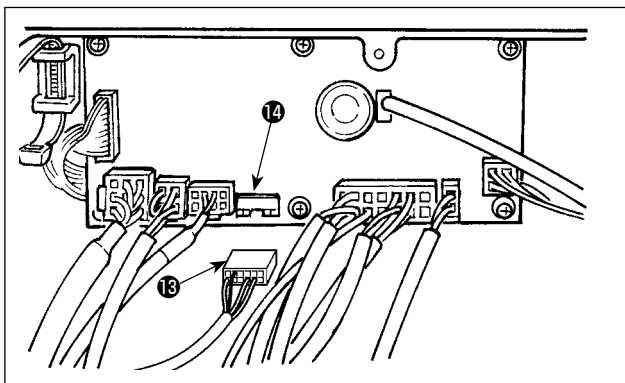

Connect the connector of PK70 13 to connector 14 (CN39 : 12P) of SC-920.

(Caution) Be sure to turn OFF the power before connecting the connector.

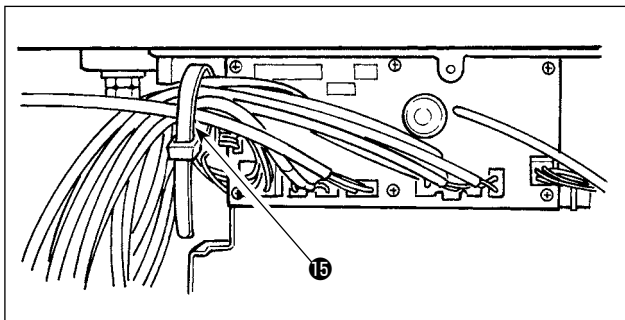

7) After inserting the connector, put all cords together with cable clip band 15 located on the side of the box.

- (Caution)
1. Fix the cord clamp and the cable clip band following the attaching procedure.
  2. When removing the connector, remove it from the wire saddle and remove it while pressing the hook of the cable clip band.

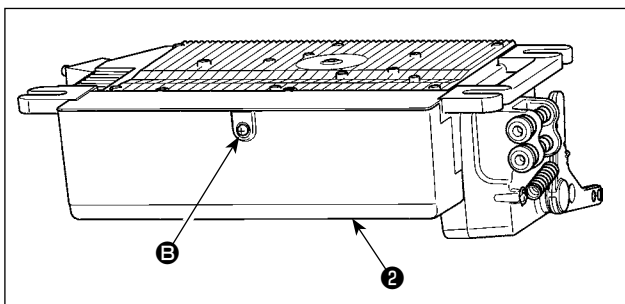
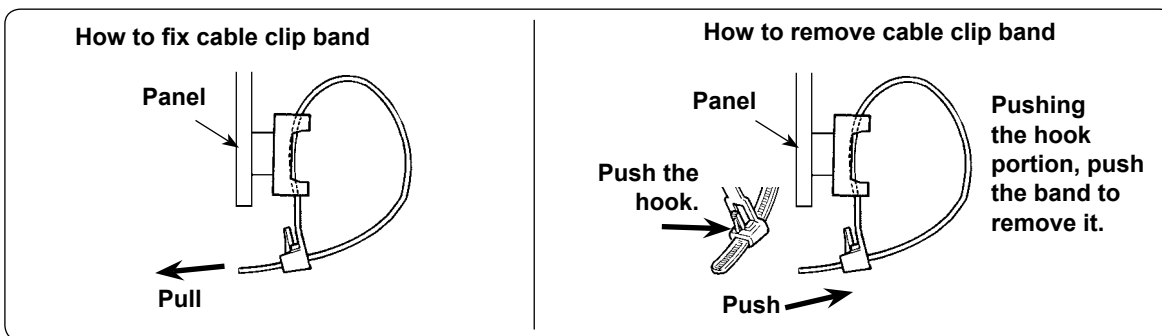

8) Close cover 2 and fix the cover by tightening screw E with a screwdriver.

(Caution) Take care not to allow the cord to be caught under cover 2.

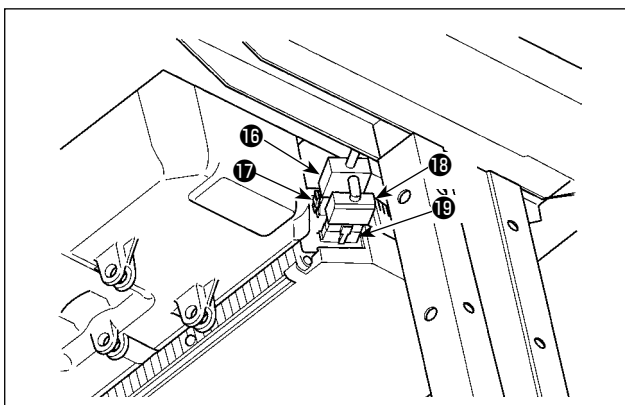

9) Connect connector 4P 16 to connector 17 located on the side of the box.

10) Connect motor output cord 18 of the power switch to connector 19.

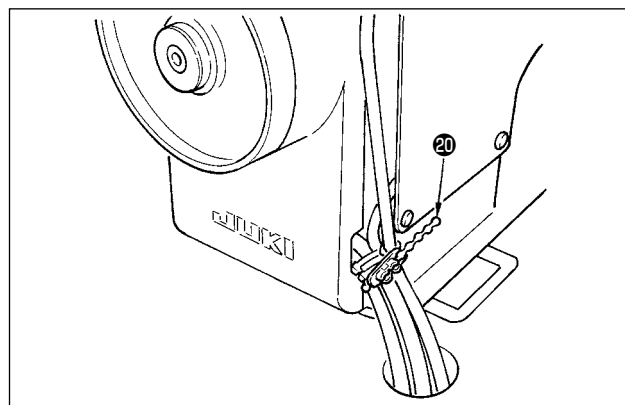

11) Bundle the machine head cables with a cable clip 20 supplied with the operation panel at one location as shown in the figure.

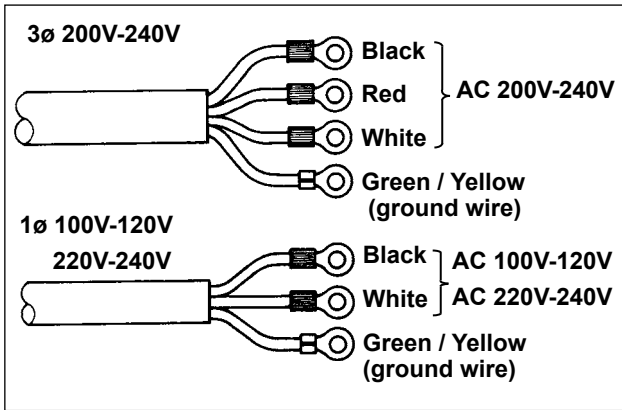

12) Connect the power supply cord to the power plug socket. Connect, as shown in the figure, the white and black (and red) conductors or the brown and blue conductors to the power supply side and the green/yellow conductor to the grounding side.

- (Caution)**
1. Be sure to prepare the power plug which conforms to the safety standard.
  2. Be sure to connect the earth cable (green/yellow) properly.

**[For CE specifications only]**

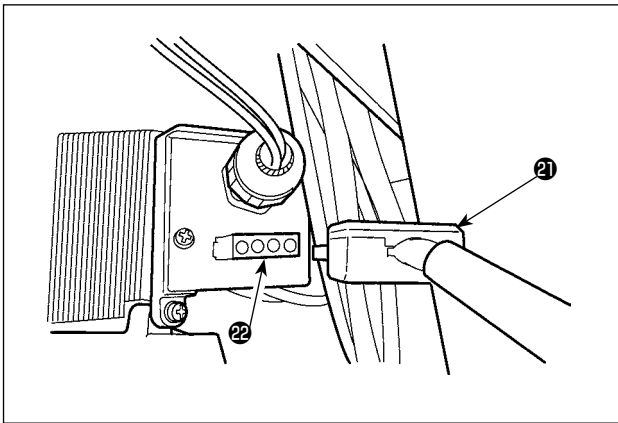

Connect motor output cord 21 to connector 22 located on the side of the box.

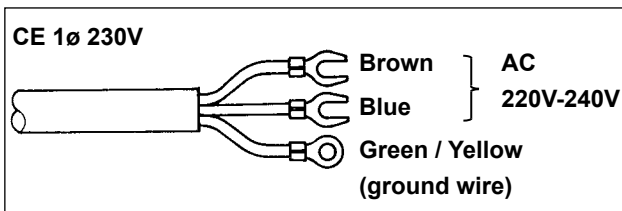

**Installing power switch**

Connect power supply cord to the power switch.

**[CE specifications]**

Single phase 230V : Power supply cords : Brown, Blue, and green/yellow (ground wire)

- (Caution)**
1. Be sure to prepare the power plug which conforms to the safety standard.
  2. Be sure to connect the earth cable (green/yellow) properly.

**[In case of using the power switch for LA]**

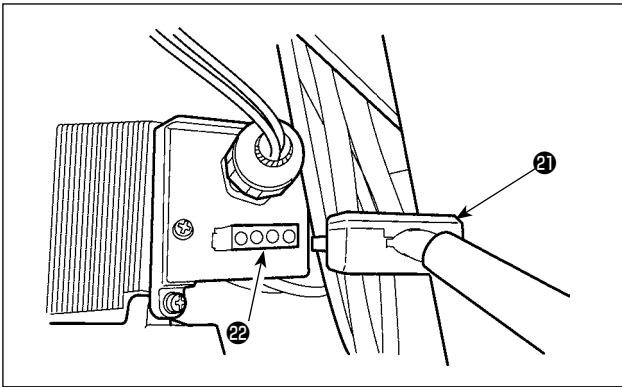

Connect motor output cord ②① to connector ②② located on the side of the box.

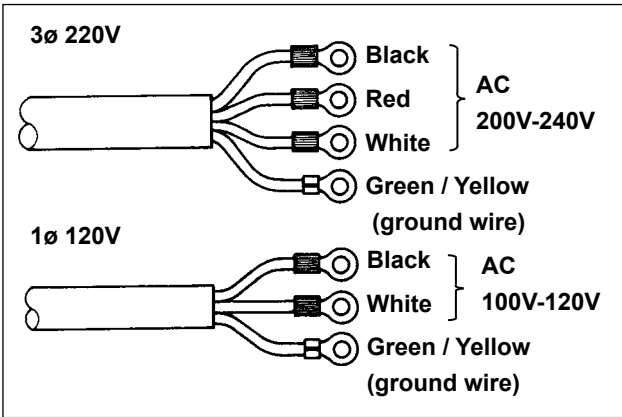

**Installing power switch**

Connect power supply cord to the power switch.

**[LA specifications]**

3-phase 220 V : Power supply cords : black, white, red and green/yellow (ground wire)  
Single phase 120V : Power supply cords : black, white, and green/yellow (ground wire)

- (Caution)**
1. Be sure to prepare the power plug which conforms to the safety standard.
  2. Be sure to connect the earth cable (green/yellow) properly.

When the metallic conduit is used, be sure to change over the power cord section following the steps of procedure described below.

**(Caution)** Be sure to carry out this procedure before installing the control box on the machine table.

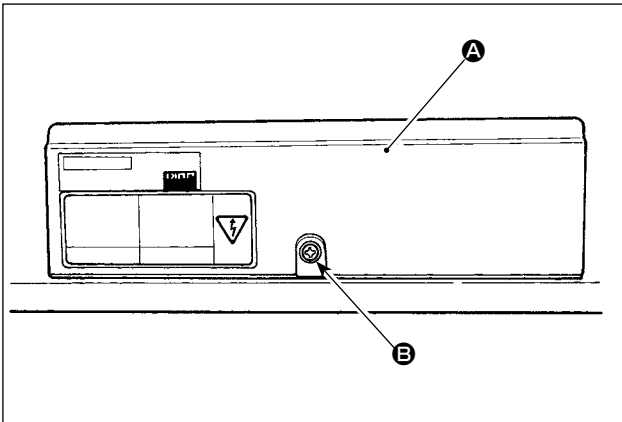

- ① Place the control box with its frame side down on the machine table as illustrated in the sketch.
- ② Loosen screw ②B in underside cover ②A to open the cover.

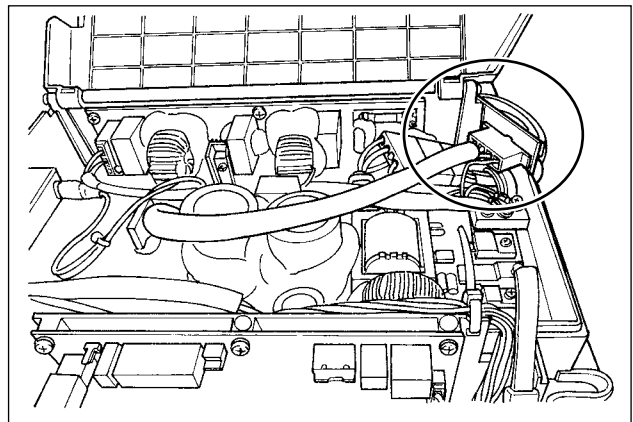

- ③ Change over the cord shown in the circle following the steps of procedure described below.

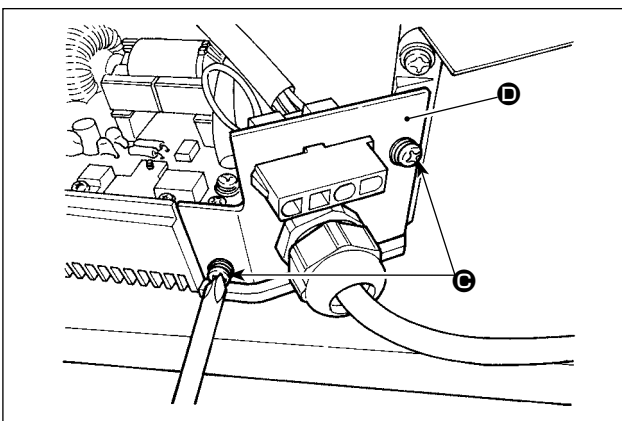

- ④ Remove two screws ④C to remove clamping plate ④D from the main body of the control box.

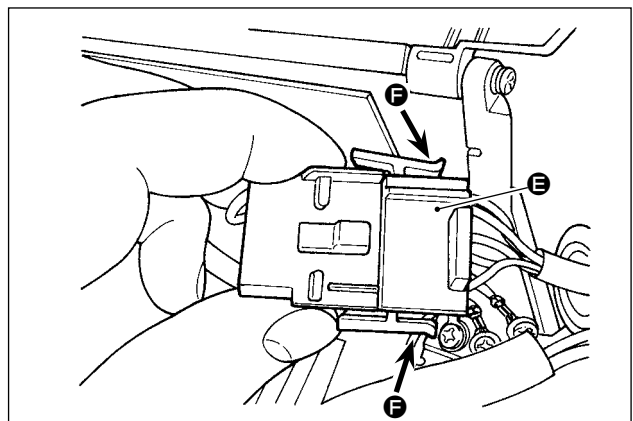

- ⑤ Remove connector ⑤E while holding its locking section ⑤F with your fingers.

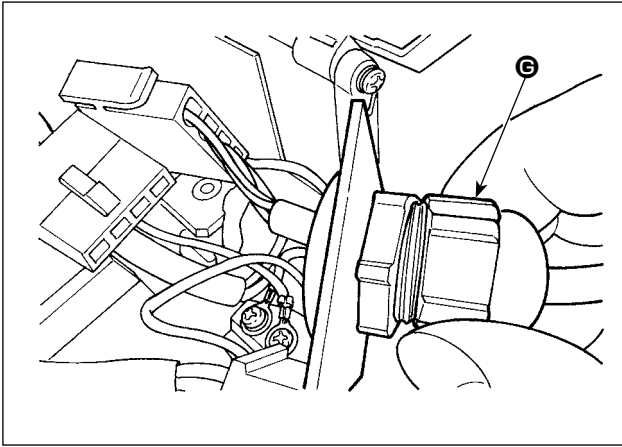

⑥ Turn connector **E** to remove the cord locking section.

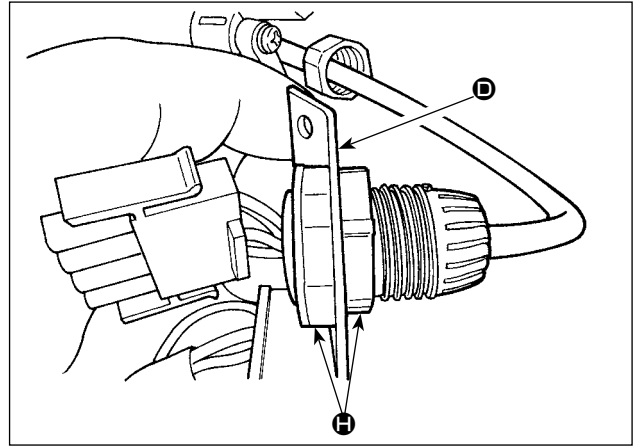

⑦ Loosen nut **H** to remove the connector from clamping plate **D**.

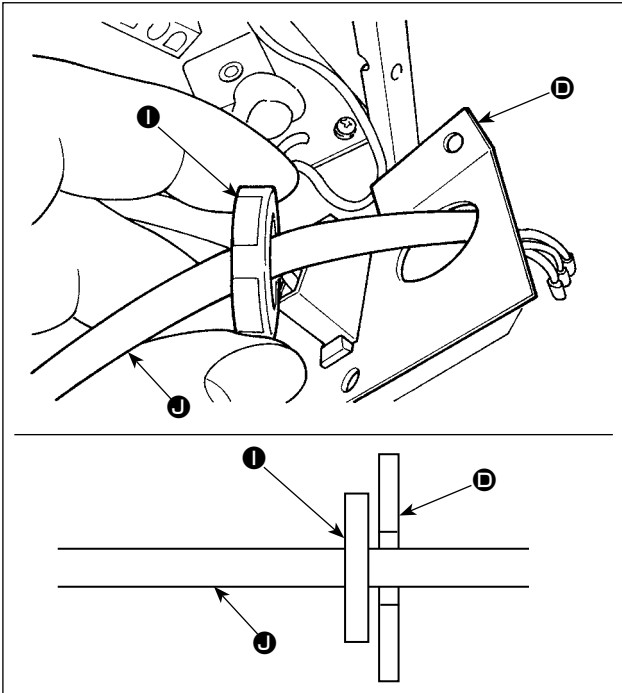

⑧ Put locknut **I** on the power cord and draw out the cord **J** from inside clamping plate **D**.

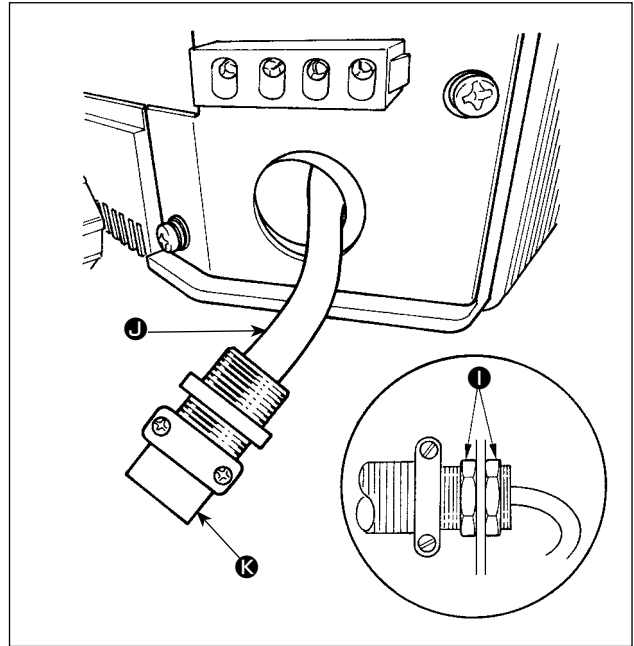

⑨ Install clamping plate **D** back to the control box.

⑩ Pass power cord **J** through conduit **K**.

⑪ Fix conduit **K** with locknuts **I** with clamping plate **D** placed between the locknuts.

⑫ Close underside cover **A** and secure the cover with screw **B**.

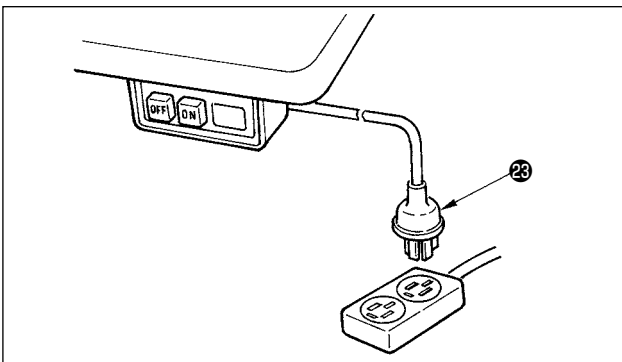
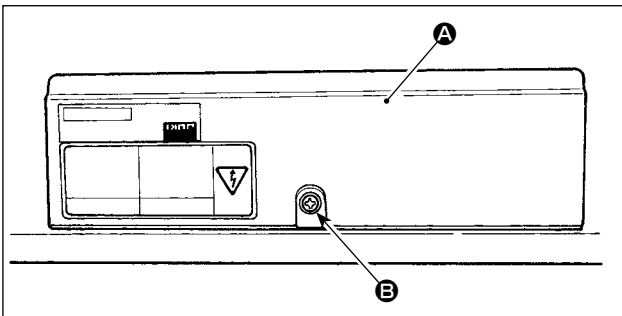

13) Make sure that the power switch is turned OFF and insert power supply cord coming from the power switch into the power plug socket.

**(Caution)** Top end of power supply cord **23** varies in accordance with destination or supply voltage. Check again the supply voltage and the voltage designated on the control box when installing the switch.

## 5. Attaching the connecting rod



### WARNING :

To protect against possible personal injury due to abrupt start of the machine, be sure to start the following work after turning the power off and a lapse of 5 minutes or more.

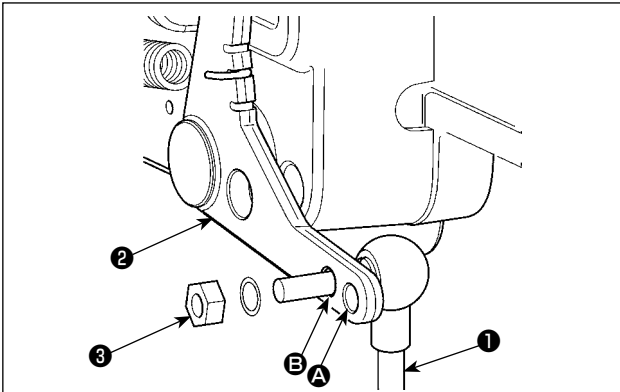

- 1) Fix connecting rod ① to installing hole ③ of pedal lever ② with nut ③ .
- 2) Installing connecting rod ① to installing hole ① will lengthen the pedal depressing stroke, and the pedal operation at a medium speed will be easier.

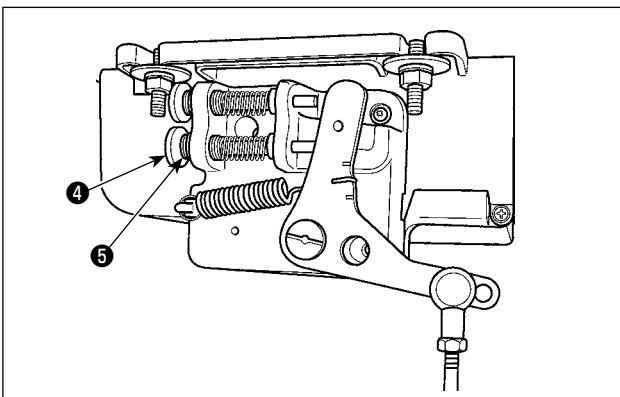

- 3) The pressure increases as you turn reverse depressing regulator screw ④ in, and decreases as you turn the screw out.

- (Caution)**
1. If the screw is excessively loosened, the spring will come off. Loosen the screw to such an extent that the top of the screw can be observed from the case.
  2. Whenever you have adjusted the screw, be sure to secure the screw by tightening metal nut ⑤ to prevent the screw from loosening.

## 6. Setting procedure of the machine head

(Caution) For the operation panel other than CP-18, refer to the Instruction Manual for the operation panel to be used for the setting procedure of the machine head.

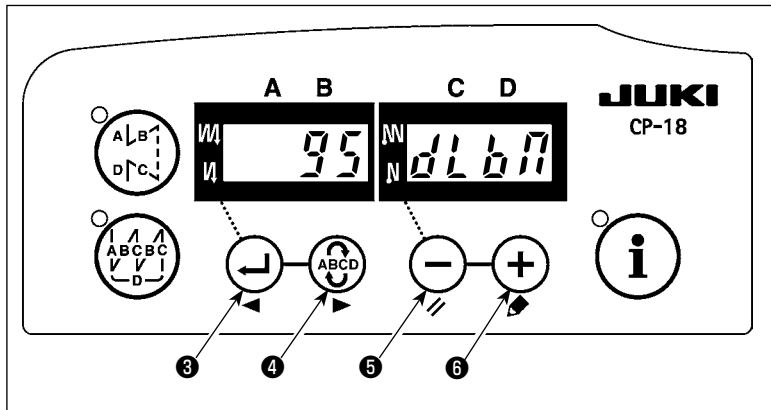

- 1) Refer to "III-6. Setting of functions of SC-920" p.24, and call the function setting No. 95.

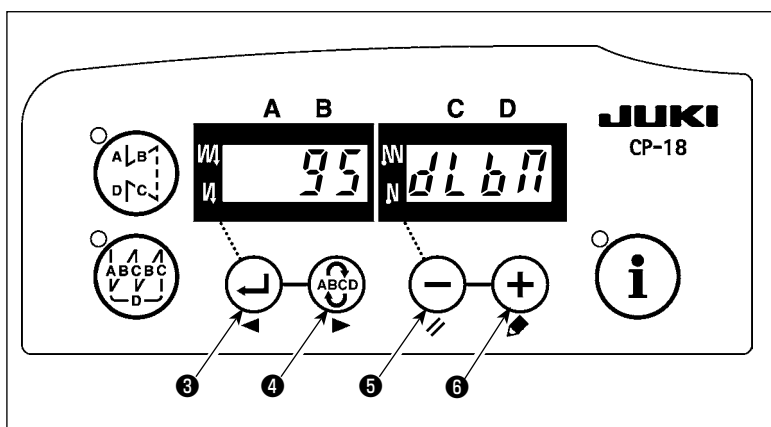

- 2) The type of machine head can be selected by pressing switch 5 ( switch 6 ).

\* Refer to the "MACHINE HEAD LIST" on the separate sheet or the Instruction Manual for the machine head of your sewing machine for the type of the machine head.

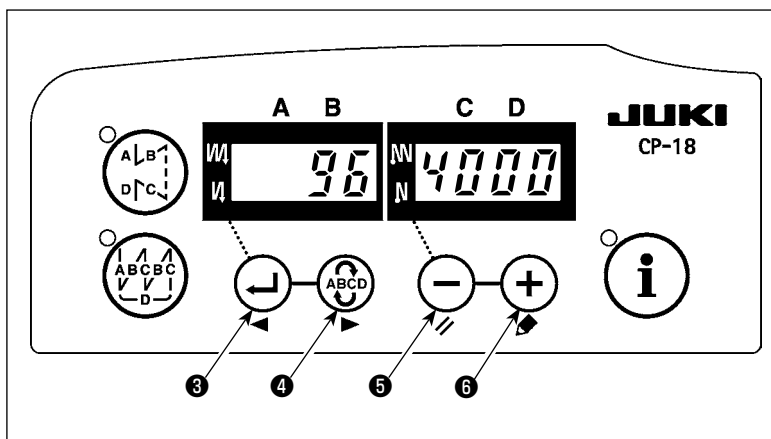

- 3) After selecting the type of machine head, by pressing switch 3 ( switch 4 ), the step proceeds to 96 or 94, and the display automatically changes to the contents of the setting corresponding with the type of machine head.

## 7. Adjusting the machine head (direct-drive motor type sewing machine only)

(Caution) When the slip between the white marker dot on the handwheel and the concave of the cover is excessive after thread trimming, adjust the angle of the machine head by the operation below.

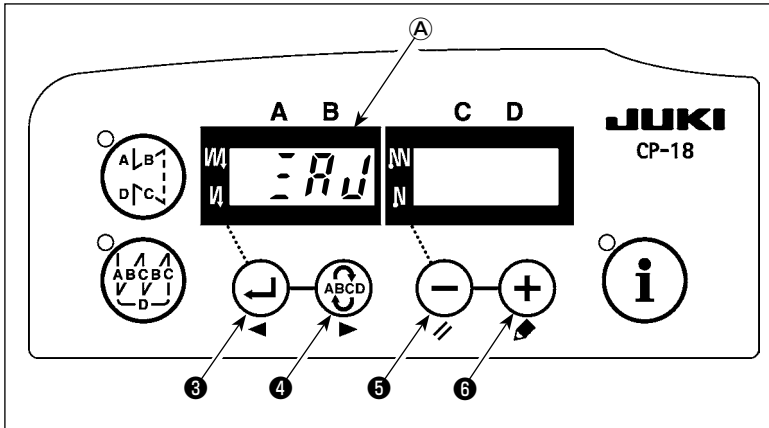

- 1) Simultaneously pressing switch (4) and switch (5), turn ON the power switch.
- 2) is displayed (A) in the indicator and the mode is changed over to the adjustment mode.

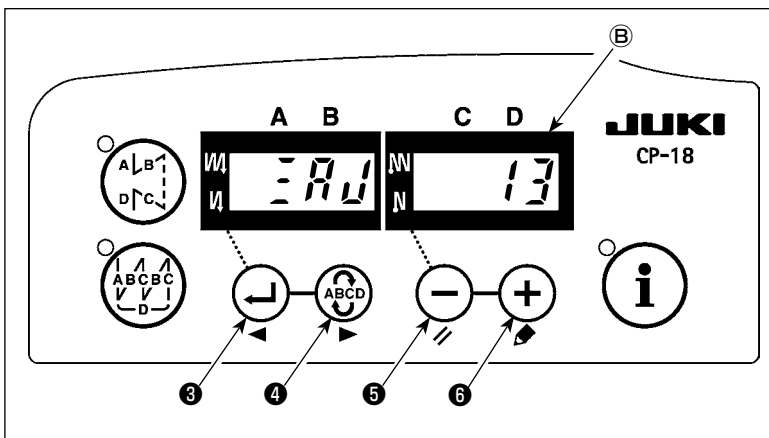

- 3) Turn the pulley of the machine head by hand until the main-shaft reference signal is detected. At this time, the degree of an angle from the main-shaft reference signal is displayed on the indicator (B). (The value is the reference value.)

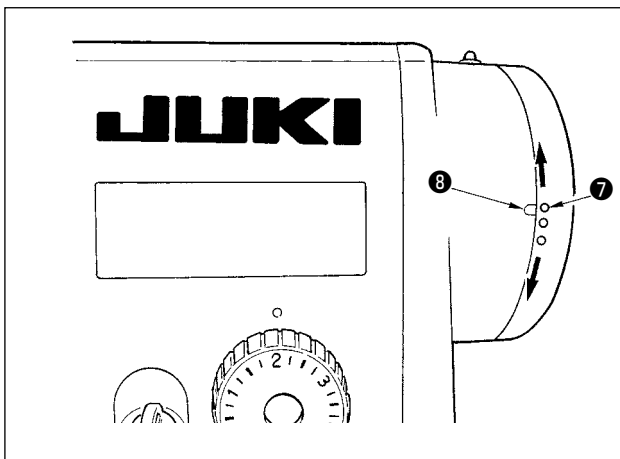

- 4) In this state, align the white dot (7) of the handwheel with the concave (8) of the pulley cover as shown in the figure.

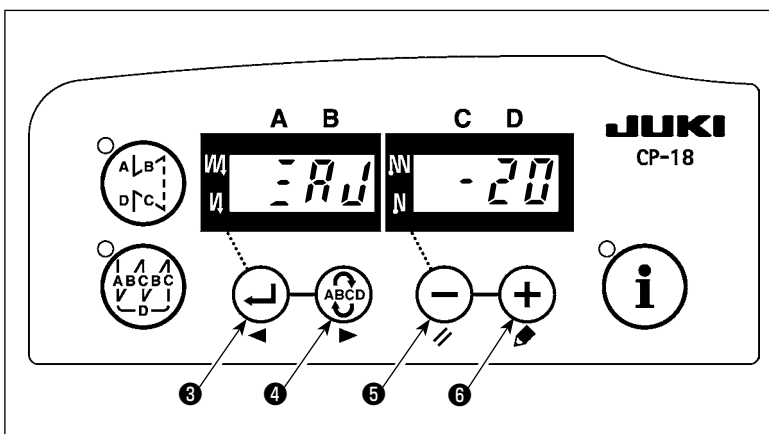

- 5) Press switch (6) to finish the adjustment work. (The value is the reference value.)



### III. FOR THE OPERATOR

#### 1. Operating procedure of the sewing machine

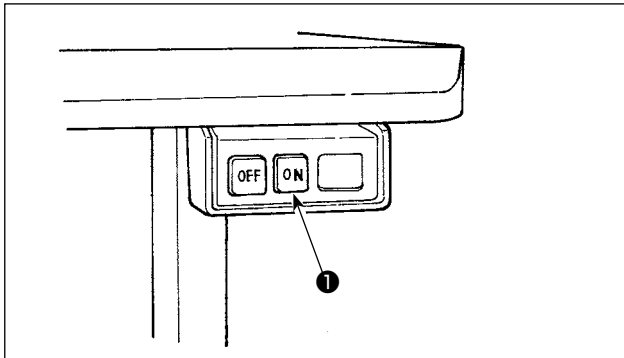

1) Press ON button ❶ of the power switch to turn ON the power.

**(Caution)** If the power indicator LED on the panel does not light up after having turned ON the power switch, immediately turn OFF the power switch and check the supply voltage. In addition, in such a case as this, re-turn ON the power switch when 2 to 3 minutes or more have passed after turning OFF the power switch.

2) When the needle bar is not in UP position, it automatically turns to the UP position.

**(Caution)** When turning ON the power for the first time, there is the case where the timing is slightly retarded to perform the initialization work. When turning ON the power, the needle bar moves. Do not put your hands or things under the needle.

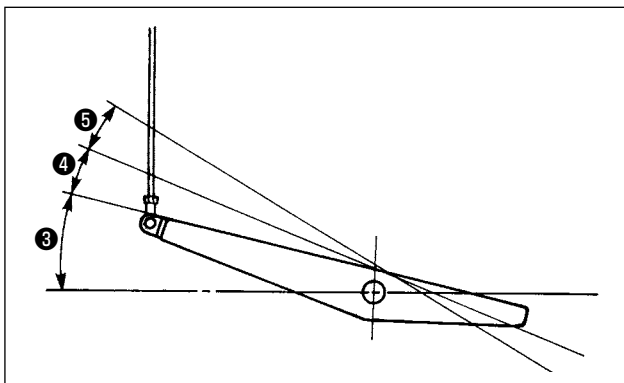

3) The pedal is operated in the following four steps:

- a. The machine runs at low sewing speed when you lightly depress the front part of the pedal. ❸
- b. The machine runs at high sewing speed when you further depress the front part of the pedal. ❹  
(If the automatic reverse feed stitching has been preset, the machine runs at high speed after it completes reverse feed stitching.)
- c. The machine stops (with its needle up or down) when you reset the pedal to its original position.
- d. The machine trims threads when you fully depress the back part of the pedal. ❺

\* When the auto-lifer (AK device) is used, one more operating switch is provided between the sewing machine stop switch and thread trimming switch. The presser foot goes up when you lightly depress the back part of the pedal ❹, and if you further depress the back part ❺, the thread trimmer is actuated.

When starting sewing from the state that the presser foot has been lifted with the Auto-lifer and you depress the back part of the pedal, the presser foot only comes down.

- If you reset the pedal to its neutral position during the automatic reverse feed stitching at seam start, the machine stops after it completes the reverse feed stitching.
- The machine will perform normal thread trimming even if you depress the back part of the pedal immediately following high or low speed sewing.
- The machine will completely perform thread trimming even if you reset the pedal to its neutral position immediately after the machine started thread trimming action.

	PFL	KFL
Presser foot operation by pedal	Enabled	Disabled
Pedal depressing depth for thread trimming	Deep	Shallow

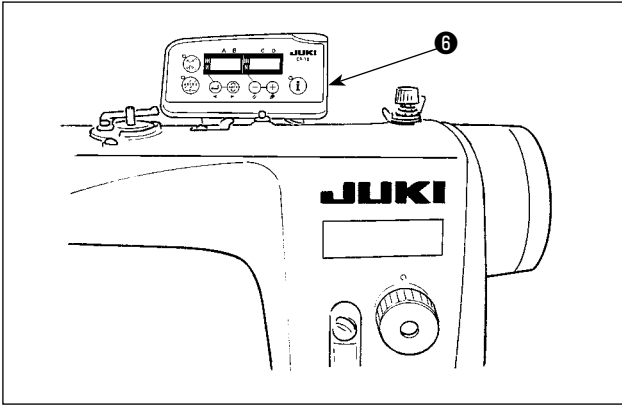

- 4) For some types of the sewing machine heads, it is possible to program various sewing patterns, using the operation panel, such as the reverse feed stitching at sewing start and that at sewing end. Refer to **“III-3. Operating procedure of the sewing pattern” p.18** for details when using CP-18 **6** . For the operation panel other than CP-18 **6** , refer to the Instruction Manual for the operation panel to be used.

(The figure given illustrates the case of the DDL-9000B.)

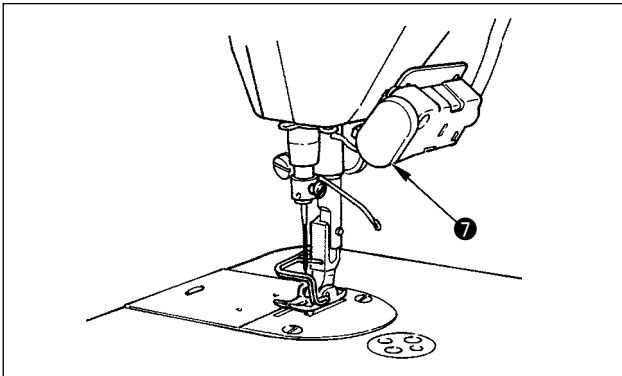

- 5) For some types of the sewing machine heads, reverse feed is performed by pressing touch-back switch **7** .



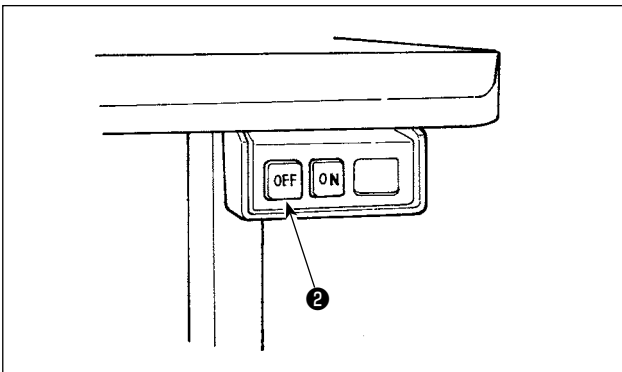



(The figure given illustrates the case of the DDL-9000B.)

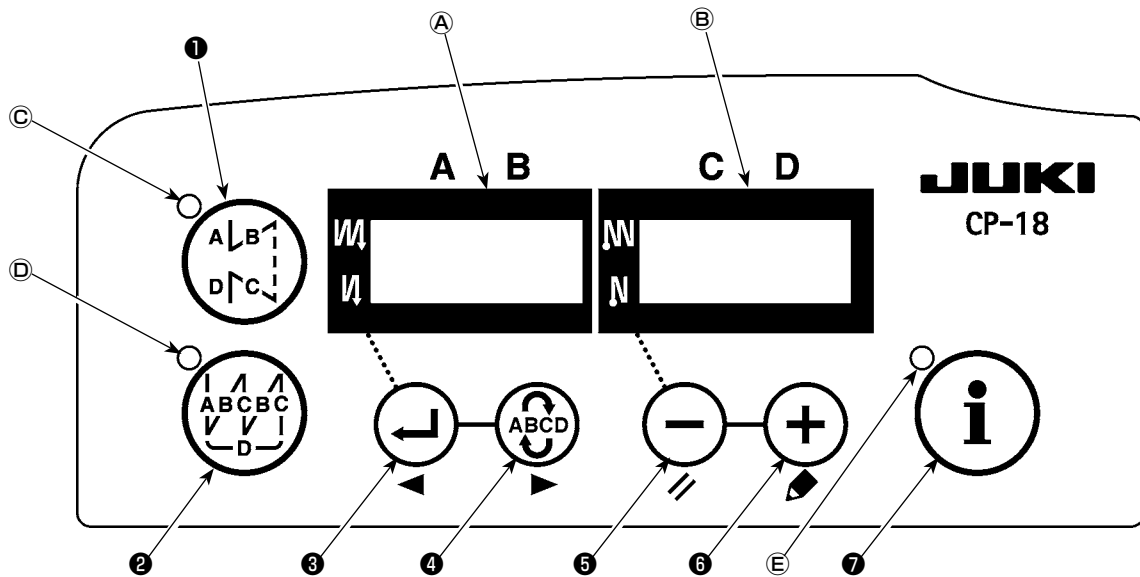

- 6) When sewing is completed, press OFF button **2** of the power switch to turn OFF the power switch after confirming that the sewing machine has stopped.

## 2. Operation panel (CP-18)



- ①  switch : Used for changing over effective/ineffective of the reverse feed stitching pattern.
- ②  switch : Used for changing over effective/ineffective of the overlapped stitching pattern.
- ③  switch : Used for confirming the contents of setting and for changing over effective/ineffective of the reverse feed stitching at sewing start.
- ④  switch : Used for selecting the process (A, B, C, D) the number of stitches for which is to be changed.  
\* The selected process flashes on and off.
- ⑤  switch : Used for changing the content of the selected display (flashing section) and for changing over effective/ineffective of the reverse stitch at sewing end.
- ⑥  switch : Used for changing the content of the selected display (flashing section).
- ⑦  switch :Used to call the production support function or one-touch setting (by keeping the switch held pressed for one second).

Indicators **A** and **B** : Various pieces of information are displayed.

LED **C** : Lights up when the reverse feed stitching pattern is effective.

LED **D** : Lights up when the overlapped stitching pattern is effective.

LED **E** : Lights up when the production support function is displayed.

### 3. Operating procedure of the sewing pattern

(Caution) For the operation panel other than CP-18, refer to the Instruction Manual for the operation panel to be used.

#### (1) Reverse feed stitching pattern

Reverse feed stitching at sewing start and reverse feed stitching at sewing end can be separately programmed.

[Setting procedure of the reverse feed stitching]

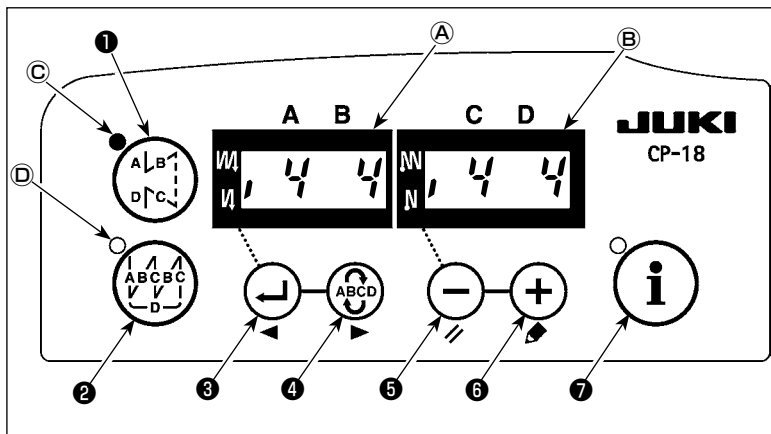

1) Effective/ineffective of the reverse feed stitching pattern can be changed over by pressing switch 1.

When the reverse feed stitching pattern is rendered effective, LED C lights up, the number of stitches of the reverse feed stitching at sewing start is displayed on A, and the number of stitches of the reverse feed stitching at sewing end is displayed on indicator B.

Select a process (A, B, C or D) the number of stitches for which is to be changed by using switch 4.

The number which is flashing on and off represents the process which is being set.

Change the number of stitches for the selected process by using switch 5 and switch 6.

Press switch 3 to confirm the change you have made. (The number of stitches that can be set is 0 to 15.)

(Caution) The sewing machine cannot perform sewing when the display of the number of stitches for a process is flashing on and off.

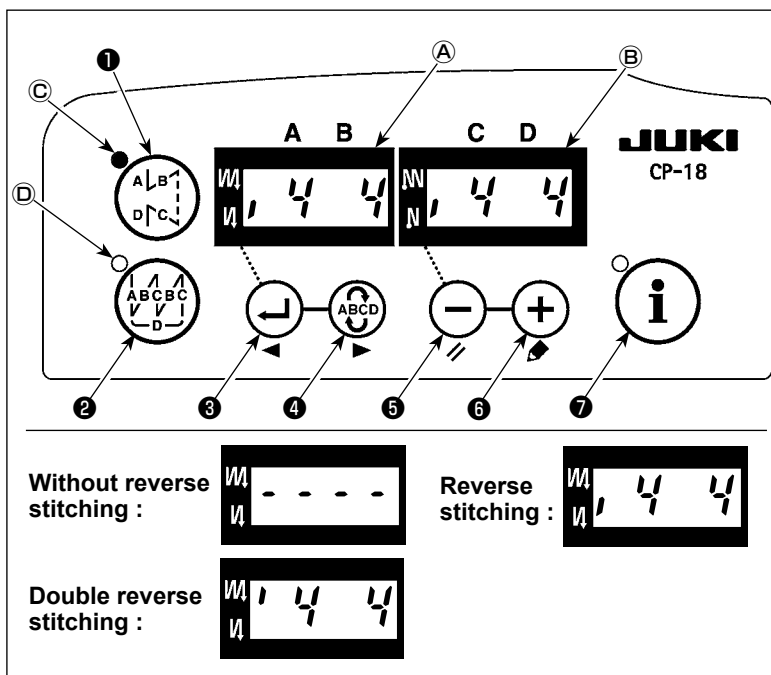

2) When the number of reverse feed stitches display is not flashing on and off, every press on switch 3 changes over the reverse feed stitching mode from the "reverse feed stitching at sewing start," "double reverse feed stitching at sewing start" and "no reverse feed stitching at sewing start."

In addition, every time switch 5 is pressed, the reverse feed stitching feature changes over from the reverse feed stitching at sewing end to the double reverse stitch at sewing end, then to no reverse feed stitching at sewing end, in turn.

(Caution) For some types of the machine head, reverse feed stitching patterns are not available.

## (2) Overlapped stitching pattern

Overlapped stitching pattern can be programmed.

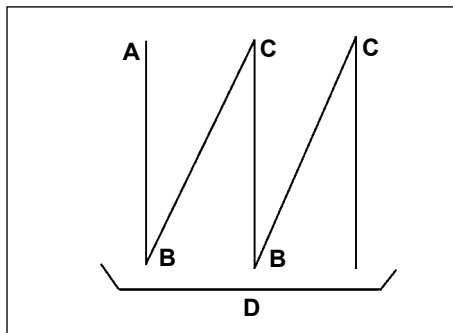

- A : Number of stitches of normal stitching setting  
0 to 15 stitches
- B : Number of stitches of reverse stitching setting  
0 to 15 stitches
- C : Number of stitches of normal stitching setting  
0 to 15 stitches
- D : Number of times of repetition  
0 to 9 times

**(Caution)** When process D is set to 5 times, the sewing is repeated as A → B → C → B → C.

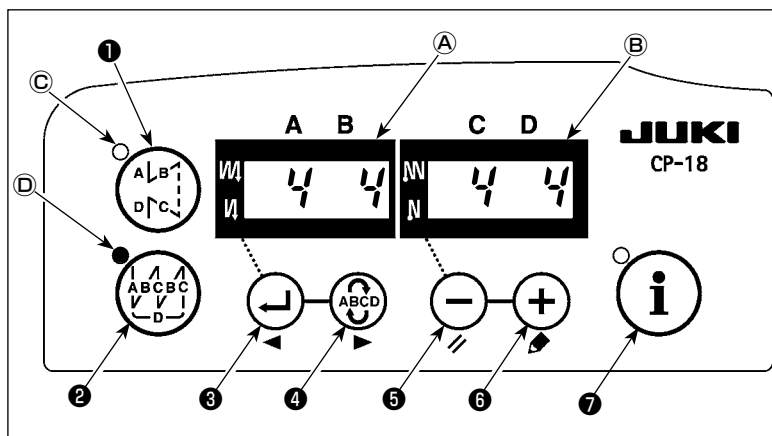

### [Setting procedure of the overlapped stitching]

- 1) Effective/ineffective of the overlapped stitching pattern can be changed over by pressing switch ②.

When the overlapped stitching pattern is rendered effective, LED lights up.

- 2) Select a process (A, B, C or D) the number of stitches for which is to be changed by using switch ④.

The number which is flashing on and off represents the process which is being set.

- 3) Change the number of stitches for the selected process by using switch ⑤ and switch ⑥.

- 4) Press switch ③ to confirm the change you have made.

(The sewing machine does not run unless the setting has been confirmed by pressing switch ③.)

**(Caution)** The overlapped stitching pattern is carried out under automatic operation mode. Once the pedal is depressed, the sewing machine will automatically perform sewing of the number of overlapped stitches.

## 4. One-touch setting

A part of function setting items can be easily changed in the normal sewing state.

**(Caution)** For the setting of functions other than those covered in this part, refer to “III-6. Setting of functions of SC-920” p.24.

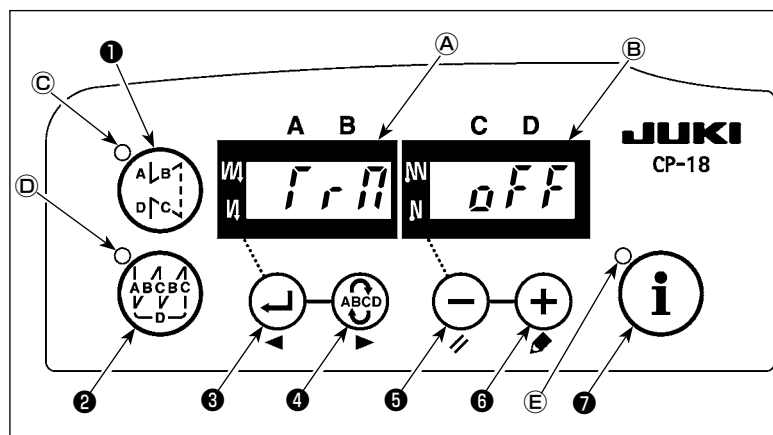

[One-touch setting procedure]

- 1) Keep **i** switch ⑦ held pressed for one second to place the panel in the function setting mode.
- 2) Change over the item to be set by using **←** switch ③ or **→** switch ④. Then, the set value can be changed by using **-** switch ⑤ and **+** switch ⑥.

- 3) To return to the normal sewing state, press **i** switch ⑦.

**(Caution)** The setting is confirmed by pressing **i** switch ⑦.

### ① Thread trimming function (*f r n*)

*OFF* : Thread trimming operation is not performed (solenoid output prohibition: Thread trimmer, wiper)  
*on* : Thread trimming operation is effective.

### ② Wiper function (*WIP*)

*OFF* : Wiper does not operate after thread trimming      *on* : Wiper operates after thread trimming

### ③ One-shot automatic stitching function (*SHOT*)

*OFF* : One-shot automatic stitching function is ineffective.      *on* : One-shot automatic stitching is effective.

**(Caution)** This function is rendered effective when the material end sensor function is set. It is not possible to prohibit the one-shot operation during overlapped sewing operation. The number of revolution is the value which is set for setting No. 38.

### ④ Setting of the max. speed of stitch (*SPD*)

The highest speed of stitch of the machine head is set. The upper limit of the set value differs with the type of machine head to which the SC is connected.

Setting range : 150 - Max. value [sti/min]

### ⑤ Material end sensor function (*ES*)

*OFF* : Material end sensor function is ineffective.

*on* : Once the material end is detected, the sewing machine stops running after having sewn the number of stitches set with ⑦ (*ESST*).

\* This function is rendered effective when the material edge sensor is set up.

### ⑥ Thread trimming function by material end sensor (*ESST*)

*OFF* : Automatic thread trimming function after the detection of material end is ineffective.

*on* : Once the material end is detected, the sewing machine performs thread trimming after having sewn the number of stitches set with ⑦ (*ESST*).

\* This function is rendered effective when the material edge sensor is set up.

### ⑦ Number of stitches for material end sensor (*ESST*)

The number of stitches to be sewn from the detection of material end to the stop of the sewing machine  
 Number of stitches that can be set: 0 to 19 (stitches)

**(Caution)** If the number of stitches specified is inadequate, the sewing machine can fail to stop within the preset number of stitches depending on the number of revolutions of the sewing machine.

## 5. Production support function

The production support function consists of three different functions (six different modes) such as the production volume management function, operation measuring function and bobbin counter function. Each of them has its own production support effect. Select the appropriate function (mode) as required.

### ■ Production volume management function

Target No. of pcs. display mode [F100]

Target/actual No. of pcs difference display mode [F200]

The target number of pieces, actual number of pieces and the difference between the target and actual number of pieces along with the operation time are displayed to notify the operators of a delay and advance in real time. Sewing machine operators are allowed to engage sewing while constantly checking his/her work pace. This helps raise target awareness, thereby increasing productivity. In addition, a delay in work can be found at an early stage to enable early detection of problems and early implementation of corrective measures.

### ■ Operation measuring function

Sewing machine availability rate display mode [F300]

Pitch time display mode [F400]

Average number of revolutions display mode [F500]

Sewing machine availability status is automatically measured and displayed on the control panel. The data obtained can be used as basic data to perform process analyses, line arrangement and equipment efficiency checkup.

### ■ Bobbin counter function

Bobbin counter display mode

In order to change bobbins before the current bobbin runs out of thread, the time for replacing the bobbin is notified.

#### [To use the production support mode]

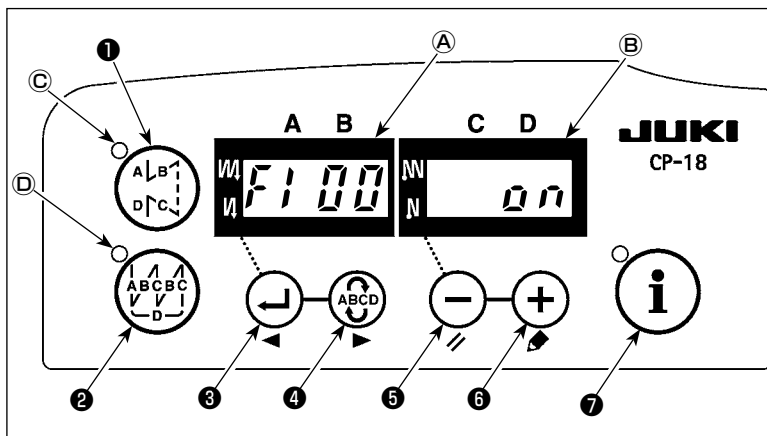

**(Caution)** Modes F100 to F500 have been factory-set in the OFF state at the time of delivery.

The mode state is changed over to ON/OFF according to the setting of the bobbin thread counter function (function setting No. 6).

Keep **i** switch 7 held pressed (one second) in the normal sewing state to call the one-touch setting screen.

Then, press **A|B|C|D** switch 1 or **A|B|C|D** switch 2 to set each production support mode in ON/OFF state to call the one-touch setting screen.

Press **←** switch 3 or **ABCD** switch 4 to select the mode to be set in the ON/OFF state.

ON/OFF of the display can be changed

over by pressing **-** switch 5 or **+** switch 6.

To return to the normal sewing state,

press **i** switch 7.

Sewing can be performed with the production support data displayed on the control panel.

**[Basic operation of the production support modes]**

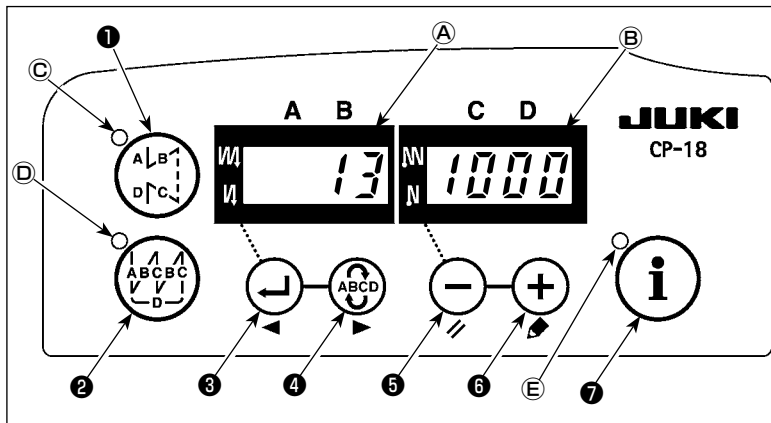

- 1) When **i** switch **7** is pressed in the normal sewing state, LED **E** lights up to enter the production support mode.
- 2) Production support function can be changed over by pressing **←** switch **3** or **ABCD** switch **4**.

3) Data attached marked with (\*1) in Table 1 "Indicator **A**" can be changed by means of **−** switch **5** and **+** switch **6**.

4) When you keep **+** switch **6** held pressed for two seconds, indicator **B** and LED **E** flash on and off. While they are flashing on and off, data marked with (\*2) in Table 1 "Display under modes" can be changed by pressing **−** switch **5** and **+** switch **6**.

When you press **i** switch **7**, the value marked with (\*2) is confirmed and indicator **B** and LED **E** stop flashing on and off.

5) The value with a sharp mark (\*3) in Table 1 "Display of modes" can be changed only immediately after resetting by using **−** switch **5** and **+** switch **6**.

6) Refer to the table "Mode resetting operation," for the resetting procedure of data.

7) To return to the normal sewing state, press **i** switch **7**.

Data to be displayed under the respective modes are as described in the table below.

**Table 1: Display of modes**

Mode name	Indicator <b>A</b>	Indicator <b>B</b>	Indicator <b>B</b> (when <b>−</b> switch <b>5</b> is pressed)
Target No. of pcs. display mode (F100)	Actual number of pieces (Unit : piece) (*1)	Target number of pieces (Unit : piece) (*2)	-
Target/actual No. of pcs. difference display mode (F200)	Difference between target number of pieces and actual number of pieces (d : piece) (*1)	Target pitch time (Unit : 100 msec) (*2)	-
Sewing machine availability rate display mode (F300)	oP-r	Sewing machine availability rate in the previous sewing (Unit : %)	Display of average availability rate of sewing machine (Unit : %)
Pitch time display mode (F400)	Pi-T	Pitch time in the previous sewing (Unit : 1sec)	Display of average pitch time (Unit : 100 msec)
Average number of revolutions display mode (F500)	ASPd	Average number of revolutions in the previous sewing (Unit : sti/min)	Display of average number of revolutions (Unit : sti/min)
Bobbin counter display mode	bbn	Bobbin counter value (*3)	-



**Table 2: Mode resetting operation**

Mode name	⊖ switch ⑤ (held pressed for 2 seconds)	⊖ switch ⑤ (held pressed for 4 seconds)
Target No. of pcs. display mode (F100)	Resets the actual number of pieces Resets the difference between target number of pieces and actual number of pieces	-
Target/actual No. of pcs. difference display mode (F200)	Resets the actual number of pieces Resets the difference between target number of pieces and actual number of pieces	-
Sewing machine availability rate display mode (F300)	Resets average availability rate of sewing machine	Resets average availability rate of sewing machine. Resets average pitch time. Resets average number of revolutions of sewing machine.
Pitch time display mode (F400)	Resets average pitch time	Resets average availability rate of sewing machine. Resets average pitch time. Resets average number of revolutions of sewing machine.
Average number of revolutions display mode (F500)	Resets average number of revolutions of sewing machine.	Resets average availability rate of sewing machine. Resets average pitch time. Resets average number of revolutions of sewing machine.
Bobbin counter display mode	Resets the bobbin counter value (Note that only the bobbin counter is immediately reset by pressing ⊖ switch ⑤ .)	-

**[Detailed setting of production volume management function (F101, F102)]**

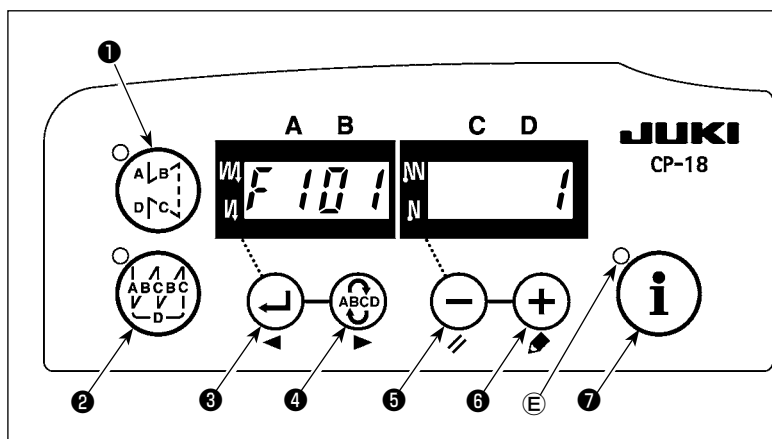

When **i** switch ⑦ is held pressed (for three seconds) under the target No. of pcs. display mode (F100) or the target/actual No. of pcs. difference display mode (F200), the detailed setting of the production volume management function can be carried out.

The setting state of the number of times of thread trimming (F101) and that of the target achievement buzzer (F102) can be changed over by pressing **↩** switch ③

or **⊙** switch ④ .

The number of times of thread trimming for sewing one piece of garment can be set by pressing **⊖** switch ⑤ or **⊕** switch ⑥ in the setting state of the number of times of thread trimming (F101).

It is possible to set whether the buzzer sounds or not when the actual number of pieces has reached the target volume by pressing **⊖** switch ⑤ or **⊕** switch ⑥ in the setting state of the target achievement buzzer (F102).

## 6. Setting of functions of SC-920

Functions can be selected and specified.

**(Caution)** For the function setting procedure of any operation panel other than CP-18, refer to the Instruction Manual for the operation panel to be used.

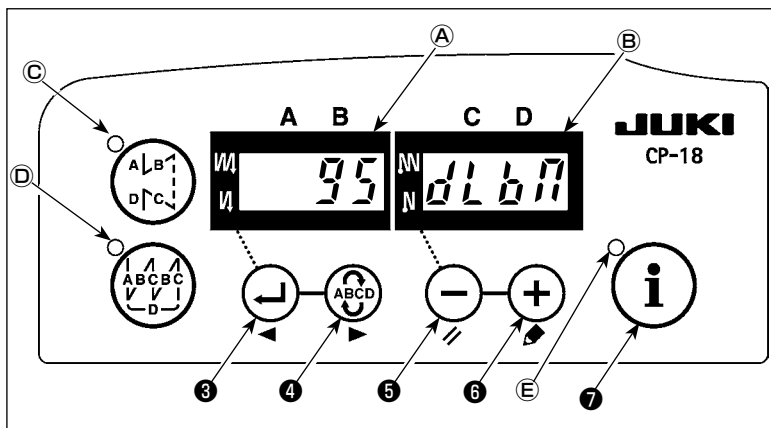
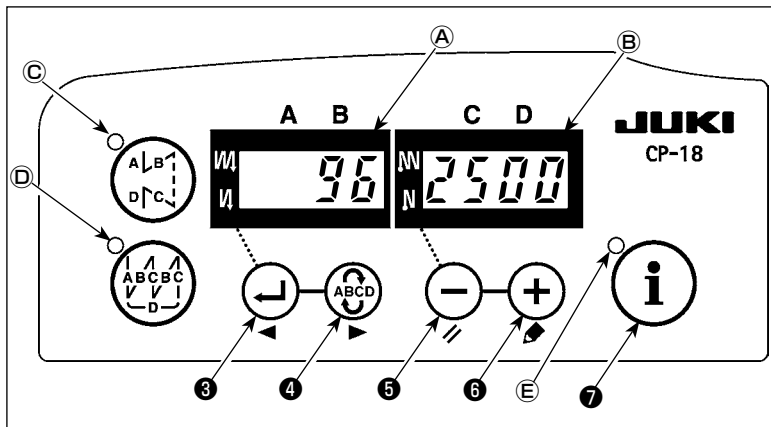
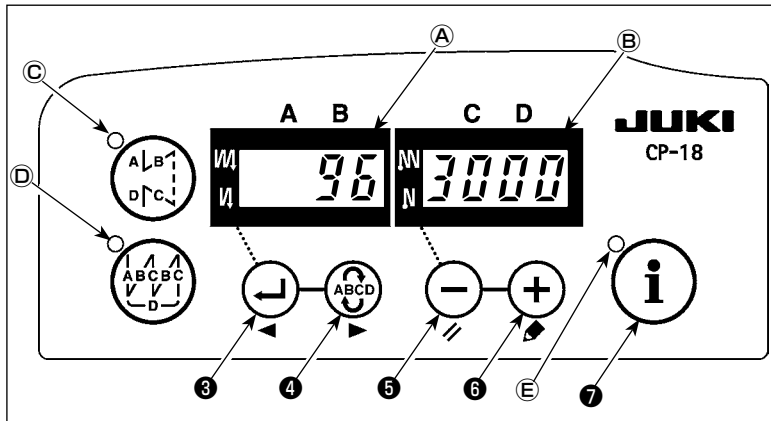

- 1) Turn ON the power with switch **7** held pressed.

(The item which has been changed during the previous work is displayed.)

\* If the screen display does not change, re-carry out operation described in step 1).

**(Caution)**

Be sure to re-return ON the power switch when one or more seconds have passed after turning it OFF. If the power switch is re-turned ON immediately after turning it OFF, the sewing machine may fail to operate normally. In such a case, be sure to turn ON the power switch again properly.

- 2) To move the setting No. forward, press

switch **4**. To move the setting No. backward, press switch **3**.

**(Caution)**

If the setting No. is moved forward (or backward), the previous (or subsequent) content of the setting is confirmed. Be careful when the content of a setting is changed (when the / switch is touched).

Example)

Changing the maximum number of revolutions (setting No. 96)

Press switch **3** or switch **4** to call setting No. "96."

The current set value is displayed on indicator **B**.

Press switch **5** to change the setting to "2500."

\* The content of setting of the setting No. returns to the initial value by pressing switch **5** and switch **6** simultaneously.

- 3) After completion of the changing procedure, press switch **3** or switch **4** to confirm the updated value.

**(Caution)** If the power is turned OFF before carrying out this procedure, the changed content is not updated.

When switch **3** is pressed, the display on the panel changes to the previous setting No. When

switch **4** is pressed, the display on the panel changes to the subsequent setting No. After completion of the operation, the machine is returned to the normal sewing state by turning OFF the power and re-returning it ON.

## 7. Function setting list

No.	Item	Description	Setting range	Indication of function setting	Ref. page
1	Soft start function	The number of stitches to be sewn at a low speed when the soft-start function is used at the start of sewing. 0 : The function is not selected. 1 to 9 : The number of stitches to be sewn under the soft-start mode.	0 to 9 (stitches)	<input type="text" value=""/> <input type="text" value=""/> <input type="text" value=""/> <input type="text" value="1"/> <input type="text" value=""/> <input type="text" value=""/> <input type="text" value=""/> <input type="text" value="0"/>	29
2	Material end sensor function	Material end sensor function (to be used only with CP-18). 0 : Material end detection function is not operative. 1 : After detecting material end, the specified number of stitches (No. 4) will be sewn, and the sewing machine will stop.	0/1	<input type="text" value=""/> <input type="text" value=""/> <input type="text" value=""/> <input type="text" value="2"/> <input type="text" value=""/> <input type="text" value=""/> <input type="text" value=""/> <input type="text" value="0"/>	29
3	Thread trimming function by material end sensor	Thread trimming function by material end sensor (to be used only with CP-18). 0 : Automatic thread trimming function after detection of material end is not operative. 1 : After detecting material end, the specified number of stitches (No. 4) will be sewn, and the sewing machine will stop and perform automatic thread trimming.	0/1	<input type="text" value=""/> <input type="text" value=""/> <input type="text" value=""/> <input type="text" value="3"/> <input type="text" value=""/> <input type="text" value=""/> <input type="text" value=""/> <input type="text" value="0"/>	29
4	Number of stitches for material end sensor	Number of stitches for material end sensor (to be used only with CP-18). Number of stitches from detection of material end to stop of the sewing machine.	0 to 19 (stitches)	<input type="text" value=""/> <input type="text" value=""/> <input type="text" value=""/> <input type="text" value="4"/> <input type="text" value=""/> <input type="text" value=""/> <input type="text" value=""/> <input type="text" value="5"/>	29
5	Flicker reducing function	Flicker reducing function 0 : Flicker reducing function is not operative. 1 : Flicker reducing function is effective	0/1	<input type="text" value=""/> <input type="text" value=""/> <input type="text" value=""/> <input type="text" value="5"/> <input type="text" value=""/> <input type="text" value=""/> <input type="text" value=""/> <input type="text" value="0"/>	29
6	Bobbin thread counting function	Bobbin thread counting function 0 : Bobbin thread counting function is not operative. 1 : Bobbin thread counting function is operative.	0/1	<input type="text" value=""/> <input type="text" value=""/> <input type="text" value=""/> <input type="text" value="6"/> <input type="text" value=""/> <input type="text" value=""/> <input type="text" value=""/> <input type="text" value="1"/>	29
7	Unit of bobbin thread counting down	Unit of bobbin thread counting down 0 : 1 Count/10 stitches 1 : 1 Count/15 stitches 2 : 1 Count/20 stitches 3 : 1 Count/thread trimming	0 to 3	<input type="text" value=""/> <input type="text" value=""/> <input type="text" value=""/> <input type="text" value="7"/> <input type="text" value=""/> <input type="text" value=""/> <input type="text" value=""/> <input type="text" value="0"/>	
8	Number of rotation of reverse feed stitching	Sewing speed of reverse feed stitching	150 to 3,000 (sti/min)	<input type="text" value=""/> <input type="text" value=""/> <input type="text" value=""/> <input type="text" value="8"/> <input type="text" value=""/> <input type="text" value="1"/> <input type="text" value="9"/> <input type="text" value=""/> <input type="text" value="0"/> <input type="text" value=""/> <input type="text" value="0"/>	
9	Thread trimming prohibiting function	Thread trimming prohibiting function (to be used only with CP-18). 0 : Thread trimming is effective. 1 : Thread trimming is prohibited. (Output of solenoid is prohibited. : Thread trimmer and wiper)	0/1	<input type="text" value=""/> <input type="text" value=""/> <input type="text" value=""/> <input type="text" value="9"/> <input type="text" value=""/> <input type="text" value=""/> <input type="text" value=""/> <input type="text" value="0"/>	29
10	Setting of needle bar stop position when the sewing machine stops.	Position of needle bar is specified when the sewing machine stops. 0 : The needle bar stops at its lower position. 1 : The needle bar stops at its upper position.	0/1	<input type="text" value=""/> <input type="text" value=""/> <input type="text" value=""/> <input type="text" value="1"/> <input type="text" value=""/> <input type="text" value="0"/> <input type="text" value=""/> <input type="text" value=""/> <input type="text" value=""/> <input type="text" value="0"/>	29
11	Operation confirmation sound for operation panel	Operation confirmation sound for operation panel 0 : Operation confirmation sound is not generated. 1 : Operation confirmation sound is generated.	0/1	<input type="text" value=""/> <input type="text" value=""/> <input type="text" value=""/> <input type="text" value="1"/> <input type="text" value=""/> <input type="text" value=""/> <input type="text" value=""/> <input type="text" value="1"/> <input type="text" value=""/> <input type="text" value=""/> <input type="text" value=""/> <input type="text" value="1"/>	29
12	Optional switch function selection	Switching of function of optional switch.		<input type="text" value=""/> <input type="text" value=""/> <input type="text" value=""/> <input type="text" value="1"/> <input type="text" value=""/> <input type="text" value=""/> <input type="text" value=""/> <input type="text" value="2"/> <input type="text" value=""/> <input type="text" value="o"/> <input type="text" value=""/> <input type="text" value="P"/> <input type="text" value=""/> <input type="text" value="T"/> <input type="text" value=""/> <input type="text" value=""/>	30
13	Function of prohibiting start of the sewing machine by bobbin thread counter	Function of prohibiting start of the sewing machine by bobbin thread counting 0 : When counting is out (-1 or less) Function of prohibiting start of the sewing machine is not operative. 1 : When counting is out (-1 or less) Function of prohibiting start of the sewing machine after thread trimming is operative. 2 : When counting is out (-1 or less), the sewing machine stops once. Function of prohibiting start of the sewing machine after thread trimming is operative.	0 to 2	<input type="text" value=""/> <input type="text" value=""/> <input type="text" value=""/> <input type="text" value="1"/> <input type="text" value=""/> <input type="text" value=""/> <input type="text" value=""/> <input type="text" value="3"/> <input type="text" value=""/> <input type="text" value=""/> <input type="text" value=""/> <input type="text" value="0"/>	
14	Sewing counter	Counting function of sewing (number of completion of process) 0 : Sewing counter function is not operative. 1 : Sewing counter function is operative. (Every time thread trimming is performed) 2 : With the sewing counting switch input function	0 to 2	<input type="text" value=""/> <input type="text" value=""/> <input type="text" value=""/> <input type="text" value="1"/> <input type="text" value=""/> <input type="text" value=""/> <input type="text" value=""/> <input type="text" value="4"/> <input type="text" value=""/> <input type="text" value=""/> <input type="text" value=""/> <input type="text" value=""/> <input type="text" value="1"/>	33
15	Thread wiping function after thread trimming	Thread wiping operation after thread trimming is specified. 0 : Thread wiping is not carried out after thread trimming 1 : Thread wiping is carried out after thread trimming	0/1	<input type="text" value=""/> <input type="text" value=""/> <input type="text" value=""/> <input type="text" value="1"/> <input type="text" value=""/> <input type="text" value=""/> <input type="text" value=""/> <input type="text" value="5"/> <input type="text" value=""/> <input type="text" value=""/> <input type="text" value=""/> <input type="text" value="1"/>	
21	Function of automatic presser foot lifting at pedal's neutral position	Function of lifting presser foot when the pedal is in neutral position. 0 : Function of neutral automatic presser lifting is not operative. 1 : Selection of function of neutral presser lifting.	0/1	<input type="text" value=""/> <input type="text" value=""/> <input type="text" value=""/> <input type="text" value="2"/> <input type="text" value=""/> <input type="text" value=""/> <input type="text" value=""/> <input type="text" value="1"/> <input type="text" value=""/> <input type="text" value=""/> <input type="text" value=""/> <input type="text" value="0"/>	33
22	Needle up/down correction switch changeover function	Function of the needle up/down correction switch is changed over. 0 : Needle up/down compensation 1 : One stitch compensation	0/1	<input type="text" value=""/> <input type="text" value=""/> <input type="text" value=""/> <input type="text" value="2"/> <input type="text" value=""/> <input type="text" value=""/> <input type="text" value=""/> <input type="text" value="2"/> <input type="text" value=""/> <input type="text" value=""/> <input type="text" value=""/> <input type="text" value="0"/>	33

\* Do not change the set values with asterisk (\*) mark as they are functions for maintenance. If the standard set value set at the time of delivery is changed, it is in danger of causing the machine to be broken or the performance to be deteriorated. If it is necessary to change the set value, please purchase the Engineer's Manual and follow the instructions.



No.	Item	Description	Setting range	Indication of function setting	Ref. page
52	Compensation of solenoid-off timing of reverse feed stitching at the start of sewing	Compensation of releasing the solenoid for reverse feed stitching when reverse feed stitching at the start of sewing is performed.	- 36 to 36 (10°)	<input type="text" value=""/> <input type="text" value=""/> <input type="text" value="5"/> <input type="text" value="2"/> <input type="text" value=""/> <input type="text" value=""/> <input type="text" value="1"/> <input type="text" value="0"/>	35
53	Compensation of solenoid-off timing of reverse feed stitching at the end of sewing	Compensation of releasing the solenoid for reverse feed stitching when reverse feed stitching at the end of sewing is performed.	- 36 to 36 (10°)	<input type="text" value=""/> <input type="text" value=""/> <input type="text" value="5"/> <input type="text" value="3"/> <input type="text" value=""/> <input type="text" value=""/> <input type="text" value="1"/> <input type="text" value="5"/>	35
55	Foot lift after thread trimming	Function of lifting presser foot at the time of (after) thread trimming 0 : Not provided with the function of automatic lifting of work-clamp after thread trimming 1 : Provided with the function of lifting presser foot automatically after thread trimming	0/1	<input type="text" value=""/> <input type="text" value=""/> <input type="text" value="5"/> <input type="text" value="5"/> <input type="text" value=""/> <input type="text" value=""/> <input type="text" value=""/> <input type="text" value="1"/>	36
56	Reverse revolution to lift the needle after thread trimming	Function of reverse revolution to lift the needle at the time of (after) thread trimming 0 : Not provided with the function of reverse revolution to lift the needle after thread trimming 1 : Provided with the function of reverse revolution to lift the needle after thread trimming	0/1	<input type="text" value=""/> <input type="text" value=""/> <input type="text" value="5"/> <input type="text" value="6"/> <input type="text" value=""/> <input type="text" value=""/> <input type="text" value=""/> <input type="text" value="0"/>	36
58	Function of holding predetermined upper/lower position of the needle bar	Function of holding predetermined upper/lower position of the needle bar 0 : Not provided with the function of holding predetermined upper/lower position of the needle bar 1 : Provided with the function of holding predetermined upper/lower position of the needle bar (holding force is weak.) 2 : Provided with the function of holding predetermined upper/lower position of the needle bar (holding force is medium.) 3 : Provided with the function of holding predetermined upper/lower position of the needle bar (holding force is strong.)	0 to 3	<input type="text" value=""/> <input type="text" value=""/> <input type="text" value="5"/> <input type="text" value="8"/> <input type="text" value=""/> <input type="text" value=""/> <input type="text" value=""/> <input type="text" value="0"/>	36
59	Function of Auto/Manual change-over of reverse feed stitching at the start of sewing	This function can specify the sewing speed of reverse feed stitching at the start of sewing. 0 : The speed will depend on the manual operation by pedal, etc. 1 : The speed will depend on the specified reverse feed stitching speed (No. 8).	0/1	<input type="text" value=""/> <input type="text" value=""/> <input type="text" value="5"/> <input type="text" value="9"/> <input type="text" value=""/> <input type="text" value=""/> <input type="text" value=""/> <input type="text" value="1"/>	36
60	Function of stop immediately after reverse feed stitching at the start of sewing	Function at the time of completion of reverse feed stitching at the start of sewing 0 : Not provided with the function of temporary stop of the sewing machine at the time of completion of reverse feed stitching at the start of sewing 1 : Provided with the function of temporary stop of the sewing machine at the time of completion of reverse feed stitching at the start of sewing.	0/1	<input type="text" value=""/> <input type="text" value=""/> <input type="text" value="6"/> <input type="text" value="0"/> <input type="text" value=""/> <input type="text" value=""/> <input type="text" value=""/> <input type="text" value="0"/>	36
64	Change-over speed of condensation stitch or EBT (end back tack)	Initial speed when starting condensation stitch or EBT	0 to 250 (sti/min)	<input type="text" value=""/> <input type="text" value=""/> <input type="text" value="6"/> <input type="text" value="4"/> <input type="text" value=""/> <input type="text" value=""/> <input type="text" value="1"/> <input type="text" value="8"/> <input type="text" value="0"/>	
70	Function of soft-down of presser foot	Presser foot is slowly lowered. 0 : Presser foot is rapidly lowered. 1 : Presser foot is slowly lowered.	0/1	<input type="text" value=""/> <input type="text" value=""/> <input type="text" value="7"/> <input type="text" value="0"/> <input type="text" value=""/> <input type="text" value=""/> <input type="text" value=""/> <input type="text" value="0"/>	37
71	Double reverse feed stitching function	Effective/ineffective of double reverse feed stitching is changed over. (to be used only with CP-18) 0 : Ineffective 1 : Effective	0/1	<input type="text" value=""/> <input type="text" value=""/> <input type="text" value="7"/> <input type="text" value="1"/> <input type="text" value=""/> <input type="text" value=""/> <input type="text" value=""/> <input type="text" value="1"/>	
72	Sewing machine startup selecting function	Current limit at the startup of sewing machine is specified. 0 : Normal (Current limit is applied during startup) 1 : Rapid (Current limit is not applied during startup)	0/1	<input type="text" value=""/> <input type="text" value=""/> <input type="text" value="7"/> <input type="text" value="2"/> <input type="text" value=""/> <input type="text" value=""/> <input type="text" value=""/> <input type="text" value="0"/>	
73	Retry function	This function is used when needle cannot pierce materials . 0 : Retry function is not provided. 1 - 10 : Retry function is provided. 1: Needle-bar returning force before operating the retry function: 1 (small) - 10 (large)	0 to 10	<input type="text" value=""/> <input type="text" value=""/> <input type="text" value="7"/> <input type="text" value="3"/> <input type="text" value=""/> <input type="text" value=""/> <input type="text" value=""/> <input type="text" value="1"/>	37
* 74	With/without thread trimmer for MF	With/without thread trimmer for MF is selected. 0 : Not provided with the thread trimmer 1 : Provided with the thread trimmer	0/1	<input type="text" value=""/> <input type="text" value=""/> <input type="text" value="7"/> <input type="text" value="4"/> <input type="text" value=""/> <input type="text" value=""/> <input type="text" value=""/> <input type="text" value="0"/>	
76	One-shot function	One-shot operation up to the material end is specified. (to be used only with CP-18) 0 : One-shot operation is not performed. 1 : One-shot operation is performed.	0/1	<input type="text" value=""/> <input type="text" value=""/> <input type="text" value="7"/> <input type="text" value="6"/> <input type="text" value=""/> <input type="text" value=""/> <input type="text" value=""/> <input type="text" value="0"/>	29
* 84	Initial motion suction time of presser foot lifting solenoid	Suction motion time of presser foot lifting solenoid	50 to 500 (ms)	<input type="text" value=""/> <input type="text" value=""/> <input type="text" value="8"/> <input type="text" value="4"/> <input type="text" value=""/> <input type="text" value=""/> <input type="text" value="1"/> <input type="text" value="4"/> <input type="text" value="0"/>	37

\* Do not change the set values with asterisk (\*) mark as they are functions for maintenance. If the standard set value set at the time of delivery is changed, it is in danger of causing the machine to be broken or the performance to be deteriorated. If it is necessary to change the set value, please purchase the Engineer's Manual and follow the instructions.

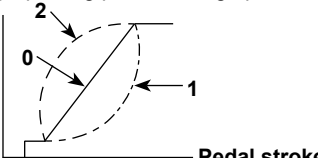
No.	Item	Description	Setting range	Indication of function setting	Ref. page
87	Function of pedal curve selection	Pedal curve is selected. (Improving pedal inching operation)  <b>Number of rotations</b> 	0/1/2	<input type="text" value=""/> <input type="text" value="8"/> <input type="text" value="7"/> <input type="text" value=""/> <input type="text" value=""/> <input type="text" value="0"/>	37
90	Initial motion up stop function	Automatic UP stop function is set immediately after turning ON the power. 0 : off 1 : on	0/1	<input type="text" value=""/> <input type="text" value="9"/> <input type="text" value="0"/> <input type="text" value=""/> <input type="text" value=""/> <input type="text" value="1"/>	38
91	Function of prohibiting compensation operation after turning handwheel by hand	It is effective in combination with the machine head provided with tension release function. 0 : Tension release function is ineffective. 1 : Tension release function is effective.	0/1	<input type="text" value=""/> <input type="text" value="9"/> <input type="text" value="1"/> <input type="text" value=""/> <input type="text" value=""/> <input type="text" value="1"/>	
92	Function of reducing speed of reverse feed stitching at the start of sewing	Function to reduce speed at the time of completion of reverse feed stitching at the start of sewing. 0 : Speed is not reduced. 1 : Speed is reduced.	0/1	<input type="text" value=""/> <input type="text" value="9"/> <input type="text" value="2"/> <input type="text" value=""/> <input type="text" value=""/> <input type="text" value="0"/>	37
93	Function added to needle up/down compensating switch	Operation of needle up/down compensating switch is changed after turning ON the power or thread trimming. 0 : Normal (needle up/down compensating stitching only) 1 : One stitch compensating stitching is performed only when aforementioned changeover is made. (Upper stop / upper stop)	0/1	<input type="text" value=""/> <input type="text" value="9"/> <input type="text" value="3"/> <input type="text" value=""/> <input type="text" value=""/> <input type="text" value="0"/>	38
94	Continuous + One-shot nonstop function	The function that does not stop the sewing machine by combining continuous stitching with one-shot stitching using the program sewing function which is available in the IP operation panel. 0 : Normal (The sewing machine stops when a step is completed.) 1 : The sewing machine does not stop when a step is completed and proceeds to next step.	0/1	<input type="text" value=""/> <input type="text" value="9"/> <input type="text" value="4"/> <input type="text" value=""/> <input type="text" value=""/> <input type="text" value="0"/>	38
95	Head selection function	Machine head to be used is selected. (When the machine head is changed, each setting item is changed to the initial value of the machine head.)		<input type="text" value=""/> <input type="text" value="9"/> <input type="text" value="5"/> <input type="text" value="d"/> <input type="text" value="L"/> <input type="text" value="b"/> <input type="text" value="M"/>	
96	Max. number of rotation setting	Max. number of rotation of the sewing machine head can be set. (The MAX value differs by machine head.)	150 to MAX (sti/min)	<input type="text" value=""/> <input type="text" value="9"/> <input type="text" value="6"/> <input type="text" value="4"/> <input type="text" value="0"/> <input type="text" value="0"/> <input type="text" value="0"/>	38
100	Number of stitches sewn before thread clamp works at the beginning of sewing	Sets the number of stitches to be sewn at the beginning of sewing before the thread clamp solenoid (CN36-7) starts operating 0 : Thread clamp solenoid does not operate. 1 to 9 : The number of stitches to be sewn before the thread clamp solenoid operates	0 to 9 (stitches)	<input type="text" value=""/> <input type="text" value="1"/> <input type="text" value="0"/> <input type="text" value="0"/> <input type="text" value=""/> <input type="text" value=""/> <input type="text" value="0"/>	
103	Needle cooler output OFF delay time	Delay time from the stop of sewing machine to the output OFF is specified using the needle cooler output function.	100 to 2000 (ms)	<input type="text" value=""/> <input type="text" value="1"/> <input type="text" value="0"/> <input type="text" value="3"/> <input type="text" value=""/> <input type="text" value="5"/> <input type="text" value="0"/> <input type="text" value="0"/>	
120	Main shaft reference angle compensation	Main shaft reference angle is compensated.	-60 to 60	<input type="text" value=""/> <input type="text" value="1"/> <input type="text" value="2"/> <input type="text" value="0"/> <input type="text" value=""/> <input type="text" value="-"/> <input type="text" value="2"/> <input type="text" value="3"/>	38
121	Up position starting angle compensation	Angle to detect UP position starting is compensated.	-15 to 15	<input type="text" value=""/> <input type="text" value="1"/> <input type="text" value="2"/> <input type="text" value="1"/> <input type="text" value=""/> <input type="text" value=""/> <input type="text" value=""/> <input type="text" value="5"/>	38
122	DOWN position starting angle compensation	Angle to detect DOWN position starting is compensated.	-15 to 15	<input type="text" value=""/> <input type="text" value="1"/> <input type="text" value="2"/> <input type="text" value="2"/> <input type="text" value=""/> <input type="text" value=""/> <input type="text" value=""/> <input type="text" value="0"/>	38
124	Setting of energy-saving function during standby	Setting to reduce the power consumption while the sewing machine is in standby state 0 : Energy-saving mode is ineffective 1 : Energy-saving mode is effective	0/1	<input type="text" value=""/> <input type="text" value="1"/> <input type="text" value="2"/> <input type="text" value="4"/> <input type="text" value=""/> <input type="text" value=""/> <input type="text" value=""/> <input type="text" value="0"/>	38

\* Do not change the set values with asterisk (\*) mark as they are functions for maintenance. If the standard set value set at the time of delivery is changed, it is in danger of causing the machine to be broken or the performance to be deteriorated. If it is necessary to change the set value, please purchase the Engineer's Manual and follow the instructions.

## 8. Detailed explanation of selection of functions

### ① Selection of the soft-start function (Function setting No. 1)

The needle thread may fail to interlace with the bobbin thread at the start of sewing when the stitching pitch (stitch length) is small or a thick needle is used. To solve such problem, this function (called "soft-start") is used to limit the sewing speed, thereby assuring successful formation of the starting stitches.

1 0    0 : The function is not selected.  
1 to 9 : The number of stitches to be sewn under the soft-start mode.

The sewing speed limited by the soft-start function can be changed. (Function setting No. 37)

37 800    Data setting range  
100 to MAX sti/min <10 sti/min> (The MAX value differs by machine head.)

### ② Material end sensor function (Function setting No. 2 to 4, 76)

This function is possible when the material end sensor is attached.

For details, refer to "III-15. Connection of the material end sensor" p.43 and the Instruction Manual for the material end sensor.

**(Caution)** This function is rendered effective only with the CP-18.

### ③ Flicker reducing function (Function setting No. 5)

The function reduces flickering of the hand lamp at the start of sewing.

5 0    0 : Flicker reducing function is ineffective  
1 : Flicker reducing function is effective

**(Caution)** When the flicker reducing function is set at the "Flicker reducing function is effective," the startup speed of the sewing machine decreases.

### ④ Bobbin thread counting function (Function setting No. 6)

When the control panel is used, the function subtracts from the predetermined value and indicates the used amount of bobbin thread.

For the details, refer to the instruction manual for the control panel.

6 1    0 : Bobbin thread counting function is not operative.  
1 : Bobbin thread counting function is operative.

**(Caution)** If "0" is set, the LCD indication on the control panel will go out and the bobbin thread counting function will be invalid.

### ⑤ Thread trimming prohibiting function (Function setting No. 9)

This function turns OFF thread trimming solenoid output and wiper solenoid output when thread trimming is actuated.

**(Caution)** This function is rendered effective only with the CP-18.

By this function, separate sewing material can be spliced and sewn without trimming thread.

9 0    0 : off Thread trimming is operative. (thread can be trimmed).  
1 : on Thread trimming is inoperative. (thread can not be trimmed).

### ⑥ Setting of the needle bar stop position when the sewing machine stops (Function setting No. 10)

The position of the needle bar when the pedal is in its neutral position is specified.

10 0    0 : Down The needle bar stops in the lowest position of its stroke.  
1 : Up The needle bar stops in the highest position of its stroke.

**(Caution)** If the stop position of the needle bar is set to the highest position, the thread trimming action will be taken after the needle bar comes down once to the lowest position.

### ⑦ Panel operating sound (Function setting No. 11)

Whether the panel operation generates sound or not can be selected.

11 1    0 : off Operation confirmation sound is not generated  
1 : on Operation confirmation sound is generated.

⑧ Selection of the optional input/output function (Function setting No. 12)

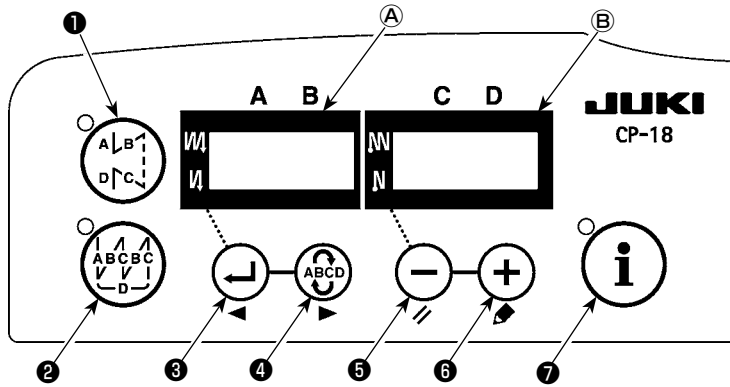

1 2 o P T \_

Select function setting No. 12 with the operating procedure of function setting procedures 1) through 3).

o P T \_ \_ E n d

Select the items of "End", "in" and "ouT" with keys ⑤ and ⑥ .

i n \_ \_

o u T \_

**[When "in" is selected]**

i 0 1 \* \* \*

The input function setting connector indication number is shown on indicating section ① . Designate the indication number by means of key ③ or ④ . Specify the function of the pin of the connector corresponding to the indication number by means of key ⑤ or ⑥ .

i 1 2

Function code and abbreviation are displayed alternately on indicator ② .

(For the relation between signal input No. and connector pin array, refer to the separate list.)

**[When "ouT" is selected]**

o 0 1 \* \* \*

The output function setting connector indication number is shown on indicating section ① . Designate the indication number by means of key ③ or ④ . Specify the function of the pin of the connector corresponding to the indication number by means of key ⑤ or ⑥ .

o 0 3

Function code and abbreviation are displayed alternately on indicator ② .

(Refer to the separate table for the relation between the signal output numbers and the connector pin configuration.)

**\* Example) To assign the thread trimming function to the input function setting connector indication number "i01" (CN36-4)**

1 2 o P T \_

1. Select function setting No. 12 with the operating procedure of function setting procedures 1) through 3).

o P T \_ i n \_ \_

2. Select the item of "in" with keys ⑤ and ⑥ .

i 0 1 n o P

3. Select the port of the indication number "i01" by means of key ④ .

i 0 1 T S W

4. Select the thread trimming function, "TSW" with keys ⑤ and ⑥ .

Lighting alternately

L \_ \_ 4

5. Determine the thread trimming function, "TSW" with key ④ .

i 0 1 L \_ \_ 4

6. Set ACTIVE of the signal with keys ⑤ and ⑥ .

Set the display to "L" when the signal is "Low" and performing thread trimming, and set the display to "H" when the signal is "High" and performing thread trimming.

H \_ \_ 4

i 0 2 S F S W

7. Determine the aforementioned function with key ④ .

o P T \_ i n \_ \_

8. Finish the optional input with key ④ .

o P T \_ \_ E n d

9. Select the item of "End" with keys ⑤ and ⑥ to return to the function setting mode.



## Input function list

Function code	Abbreviation	Function item	Remarks
0	noP	No function	(Standard setting)
1	HS	Needle up / down compensating stitching	Every time the switch is pressed, normal feed stitching by half stitch is performed. (Same operation as that of up / down compensating stitching switch on the panel.)
2	bHS	Back compensating stitching	Reverse feed stitching is performed at low speed while the switch is held pressing. (It is effective only when a constant-dimension sewing is selected.)
3	EbT	Function of canceling once reverse feed stitching at the end of sewing	By depressing the back part of the pedal after pressing the switch, operation of reverse feed stitching is canceled once.
4	TSW	Thread trimming function	This function is actuated as the thread trimming switch.
5	FL	Presser foot lifting function	This function is actuated as the foot lifter switch.
6	oHS	One stitch compensating stitching	Every time the switch is pressed, one stitch stitching operation is executed.
7	SEbT	Function of cancel of reverse feed stitching at start/end	By operating the optional switch, ineffective/effective can be alternately changed over.
8	PnFL	Presser lifting function when pedal is neutral	Every time the switch is pressed, the function whether automatically lifting the presser foot when the pedal is neutral or not can be selected.
9	Ed	Material edge sensor input	This function works as the input signal of material edge sensor.
10	LinH	Function of prohibiting depressing front part of pedal	Rotation by pedal is prohibited.
11	TinH	Function of prohibiting thread trimming output	Output of thread trimming is prohibited.
12	LSSW	Low speed command input	This function works as low speed switch for standing sewing machine.
13	HSSW	High speed command input	This function works as high speed switch for standing sewing machine.
14	USW	Needle lifting function	UP stop motion is performed when switch is pressed during DOWN stop.
15	bT	Reverse feed stitching switch input	Reverse feed stitching is output as long as the switch is held pressed.
16	SoFT	Soft start switch input	The speed of stitch is limited to the predetermined soft-start speed as long as the switch is held pressed.
17	oSsW	One-shot speed command switch input	This function works as one-shot speed command as long as the switch is pressed.
18	bKoS	Backward one-shot speed command switch input	Reverse feed stitching is performed in accordance with the one-shot speed command as long as the switch is held pressed.
19	SFSW	Safety switch input	Rotation is prohibited.
20	MES	Thread trimming safety switch input	It operates as an input signal of the thread trimmer safety switch.
21	AUbT	Automatic reverse feed stitching cancellation/addition switch	Every time the switch is pressed, reverse feed stitching at sewing start or reverse feed stitching at sewing end is cancelled or added.
22	CUnT	Sewing counter input	Every time the switch is pressed, the sewing counter value is increased.
23	Tiin	Tsw command prohibition input	Thread trimming command is prohibited.
24	USTP	Lsw command prohibition/needle-up stop input	Sewing by means of the pedal switch is prohibited. The sewing machine stops with its needle up during sewing.

## Output function list

Function code	Abbreviation	Function item	Remarks
0	noP	No function	(Standard setting)
1	TrM	Thread trimming output	Output of thread trimming signal
2	WiP	Thread wiper output	Output of thread wiper signal
3	TL	Thread release output	Output of thread release signal
4	FL	Presser lifter output	Output of presser lifting signal
5	bT	Reverse feed stitching output	Output of reverse feed stitching signal
6	EbT	EBT cancel monitor output	State of one time cancel of reverse feed stitching at end function is output.
7	SEbT	Reverse feed stitching at start/end cancel monitor output	State of cancel of reverse feed stitching at start/end is output.
8	AUbT	Sewing start/end cancellation/addition monitor output	State of cancel or addition of automatic reverse feed stitching is output.
9	SSTA	Sewing machine stop state output	Sewing machine stop state is output.
10	Cool	Needle cooler output	Output for needle cooler
11	bUZ	Buzzer output	It is output when the bobbin counter set value has been exceeded, an error has occurred or the bobbin thread remaining amount is detected.
12	LSWo	Revolution command output	Revolution demanding command state is output.
13	TSWo	Tsw command monitor output	Thread trimming command status is output.

## Input function setting connectors

Connector No.	Pin No.	Display No.	Initial value of function setting
CN36	4	i01	noP (No function setting)
CN48	2	i02	SFSW (Safety switch input)
CN50	12	i03	SoFT (Soft-start speed limit input)
CN36	5	i04	bT (Reverse feed stitching switch input)
CN50	11	i05	LinH (Input of prohibition of depress on front part of pedal)
CN39	7	i06	TSW (Thread trimming switch input)
	11	i07	LSSW (Low-speed revolution switch input)
	9	i08	HSSW (High-speed revolution switch input)
	5	i09	FL (Presser foot lifting switch input)
CN57	1	i10	CUnT (Sewing counter input)
CN42	2	i11	noP (No function setting)
CN54	3	i12	noP (No function setting)

## Output function setting connector

Connector No.	Pin No.	Display No.	Initial value of function setting
CN50	7	o01	bT (Reverse feed stitching output)
	8	o02	TrM (Thread trimming output)
	9	o03	LSWo (Revolution request input)



⑬ **Function of reverse feed stitching on the way (Function setting Nos. 30 to 33)**

Functions of the limit of number of stitches and thread trimming command can be added to the touch back switch on the sewing machine head.

Function setting No. 30      Function of reverse feed stitching on the way is selected.

**3**   **0**            **0**

0 : off    Normal back-tack function  
1 : on    Function of reverse feed stitching on the way

Function setting No. 31      Number of stitches performing reverse feed stitching is set.

**3**   **1**            **4**

Setting range  
0 to 19 stitches

Function setting No. 32      Effective condition of reverse feed stitching on the way

**3**   **2**            **0**

0 : off    Inoperative when the sewing machine stops. (Reverse feed stitching on the way functions only when the sewing machine is running.)  
1 : on    Operative when the sewing machine stops. (Reverse feed stitching on the way functions both when the sewing machine is running and stops.)

**(Caution) Either condition is operative when the sewing machine is running.**

Function setting No. 33      Thread trimming is performed when reverse feed stitching on the way is completed.

**3**   **3**            **0**

0 : off    Without thread trimming  
1 : on    Thread trimming is executed.

Appli- cation	Function setting			Output function
	No. 30	No. 32	No. 33	
①	0	0 or 1	0 or 1	It works as normal touch-back switch.
②	1	0	0	When operating touch-back switch at the time of depressing front part of the pedal, reverse feed stitching as many as the number of stitches specified by the function setting No. 31 can be performed.
③	1	1	0	When operating touch-back switch at the time of either stop of the sewing machine or depressing front part of the pedal, reverse feed stitching as many as the number of stitches specified by the function setting No. 31 can be performed.
④	1	0	1	When operating touch-back switch at the time of depressing front part of the pedal, automatic thread trimming is performed after reverse feed stitching as many as the number of stitches specified by the function setting No. 31 has been performed.
⑤	1	1	1	When operating touch-back switch at the time of either stop of the sewing machine or depressing front part of the pedal, automatic thread trimming is performed after reverse feed stitching as many as the number of stitches specified by the function setting No. 31 has been performed.

**Actions under each setting state**

- ① Used as the normal reverse feed stitching touch-back switch.
- ② Used for reinforcing seam (press sewing) of the pleats. (It works only when the sewing machine is running.)
- ③ Used for reinforcing seam (press sewing) of the pleats.  
(It works either when the sewing machine stops or when the sewing machine is running.)
- ④ Used as starting switch for reverse feed stitching at the sewing end.  
(Used as the substitute for thread trimming by depressing back part of the pedal. It works only when the sewing machine is running. It is especially effective when the sewing machine is used as the standing-work machine.)
- ⑤ Used as starting switch for reverse feed stitching at the sewing end.  
(Used as the substitute for thread trimming by depressing back part of the pedal. It works either when the sewing machine stops or when the sewing machine is running. It is especially effective when the sewing machine is used as the standing-work machine.)

⑭ **Number of rotation of one-shot stitching (Function setting No. 38)**

This function can set, by the pedal operation of one time, the sewing speed of one-shot stitching when the sewing machine continues stitching until completing the number of stitches specified or detecting the material end.

**3**   **8**   **2**   **5**   **0**   **0**

Setting range  
150 to MAX. sti/min <50 / sti/min>

**(Caution) The max. number of rotation of one-shot stitching is limited by the model of the sewing machine head.**

⑮ **Holding time of lifting presser foot (Function setting No. 47)**

This function automatically lowers the presser foot when the time set with the setting No. 47 has passed after lifting the presser foot.

When the pneumatic type presser foot lifter is selected, the holding time control of lifting presser foot is limitless regardless of the set value.

Setting range  
10 to 600 sec <10 / sec>

⑯ **Compensation of timing of the solenoid for reverse feed stitching (Function setting No. 51 to 53)**

When the normal and reverse feed stitches are not uniform under the automatic reverse feed stitching action, this function can change the ON / OFF timing of the solenoid for back tack and compensate the timing.

① Compensation of on-timing of solenoid for reverse feed stitching at the start of sewing (Function setting No. 51)

On-timing of solenoid for reverse feed stitching at the start of sewing can be compensated by the unit of angle.

Adjusting range  
- 36 to 36 <1 / 10°>

Set value	Compensation angle	Number of stitches of compensation
- 36	- 360°	- 1
- 18	- 180°	- 0.5
0	0°	0
18	180°	0.5
36	360°	1

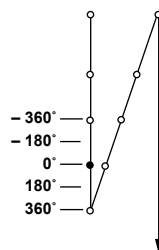

\* When the point before 1 stitch is regarded as 0°, compensation is possible by 360° (1 stitch) in front and in the rear.

② Compensation of off-timing of solenoid for reverse feed stitching at the start of sewing (Function setting No. 52)

Off-timing of solenoid for reverse feed stitching at the start of sewing can be compensated by the unit of angle.

Adjusting range  
- 36 to 36 <1 / 10°>

Set value	Compensation angle	Number of stitches of compensation
- 36	- 360°	- 1
- 18	- 180°	- 0.5
0	0°	0
18	180°	0.5
36	360°	1

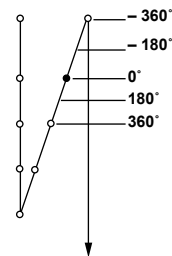

③ Compensation of off-timing of solenoid for reverse feed stitching at the end of sewing (Function setting No. 53)

Off-timing of solenoid for reverse feed stitching at the start of sewing can be compensated by the unit of angle.

Adjusting range  
- 36 to 36 <1 / 10°>

Set value	Compensation angle	Number of stitches of compensation
- 36	- 360°	- 1
- 18	- 180°	- 0.5
0	0°	0
18	180°	0.5
36	360°	1

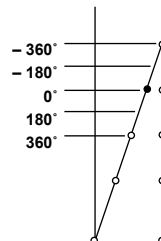

⑰ **Foot lift function after thread trimming (Function setting No. 55)**

This function can automatically lift the presser foot after thread trimming. This function is effective only when it is used in combination with the AK device.

**5**   **5**       **1**

- 0 : off Function of automatically lifting the presser foot is not provided.  
(Presser foot does not automatically go up after thread trimming.)
- 1 : on Function of automatically lifting the presser foot is provided.  
(Presser foot automatically goes up after thread trimming.)

⑱ **Reverse revolution to lift the needle after thread trimming (Function setting No. 56)**

This function is used to make the sewing machine rotate in the reverse direction after thread trimming to lift the needle bar almost to highest position. Use this function when the needle appears under the presser foot and it is likely to make scratches on the sewing products of heavy-weight material or the like.

**5**   **6**       **0**

- 0 : off Function of making the sewing machine rotate in the reverse direction to lift the needle after thread trimming is not provided.
- 1 : on Function of making the sewing machine rotate in the reverse direction to lift the needle after thread trimming is provided.

**(Caution)** The needle bar is raised, by rotating the machine in the reverse direction, almost to the highest dead point. This may result in slip-off of the needle thread. It is therefore necessary to adjust the length of thread remaining after thread trimming properly.

⑲ **Function of holding predetermined upper / lower position of the needle bar (Function setting No. 58)**

When the needle bar is in the upper position or in the lower position, this function holds the needle bar by applying a brake slightly.

**5**   **8**       **0**

- 0 : off Not provided with the function of holding predetermined upper/lower position of the needle bar
- 1 : on Provided with the function of holding predetermined upper/lower position of the needle bar (holding force is weak.)
- 2 : on Provided with the function of holding predetermined upper/lower position of the needle bar (holding force is medium.)
- 3 : on Provided with the function of holding predetermined upper/lower position of the needle bar (holding force is strong.)

⑳ **Change-over function of AUTO / Pedal for sewing speed of the reverse feed stitching at the start of sewing (Function setting No. 59)**

This function selects whether the reverse feed stitching at the start of sewing is performed without a break at the speed set by the function setting No. 8 or the stitching is performed at the speed by the pedal operation.

**5**   **9**       **1**

- 0 : Manual The speed is indicated by the pedal operation.
- 1 : Auto Automatic stitching at the specified speed

**(Caution)** 1. The max. sewing speed of the reverse feed stitching at the start of sewing is limited to the speed set by the function setting No. 8 regardless of the pedal.

2. When "0" is selected, stitches of reverse feed stitching may not match those of normal feed stitching.

㉑ **Function of stop immediately after the reverse feed stitching at the start of sewing (Function setting No. 60)**

This function temporarily stops the sewing machine even when keeping depressing the front part of the pedal at the time of completion of process of reverse feed stitching at the start of sewing.

It is used when sewing a short length by reverse feed stitching at the start of sewing.

**6**   **0**       **0**

- 0 : Not provided with the function of temporary stop of the sewing machine immediately after the reverse feed stitching at the start of sewing
- 1 : Provided with the function of temporary stop of the sewing machine immediately after the reverse feed stitching at the start of sewing

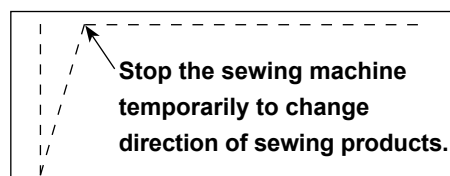

②② **Function of soft-down of presser foot (with AK device only) (Function setting No. 70 and 49)**

This function can softly lower the presser foot.

This function can be used when it is necessary to decrease contact noise, cloth defect, or slippage of cloth at the time of lowering the presser foot.

**Note :** Change the time of function setting No. 49 together at the time of selecting the function of soft-down since the sufficient effect cannot be obtained unless the time of function setting No. 49 is set longer when lowering the presser foot by depressing the pedal.

0 to 500 ms  
10 ms/Step

0 : Function of soft-down of presser foot is not operative. (Presser foot is rapidly lowered.)  
1 : Selection of function of soft-down of presser foot

②③ **Function of reducing speed of reverse feed stitching at the start of sewing (Function setting No. 92)**

Function to reduce speed at the time of completion of reverse feed stitching at the start of sewing : Normal use depending on the pedal condition (Speed is accelerated to the highest without a break.)

This function is used when temporary stop is used properly. (Cuff and cuff attaching)

0 : Speed is not reduced.  
1 : Speed is reduced.

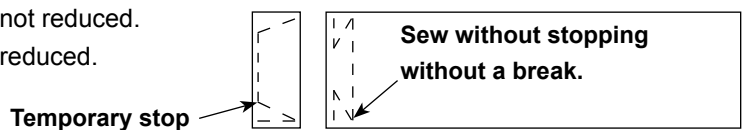

②④ **Retry function (Function setting No. 73)**

When the retry function is used, if the sewing material is thick and not pierced with needle, this function makes the needle pierce the material with ease.

0 : Retry function is not provided.  
1 - 10 : Retry function is provided.

1: Needle-bar returning force before operating the retry function: 1 (small) - 10 (large)

②⑤ **Presser foot lifting solenoid suction time setting (Function setting No. 84)**

Suction time of presser foot lifting solenoid can be changed. When heating is great, it is effective to lessen the value.

**(Caution)** When the value is excessively small, malfunction will be caused. So, be careful when changing the value.

Setting range : 50 to 250ms <10/ms>

②⑥ **Function of pedal curve selection (Function setting No. 87)**

This function can perform the selection of the curve of number of rotation of the sewing machine against the depressing amount of the pedal.

Change to this function when you feel that inching operation is hard or that pedal response is slow.

0 : Number of rotation of the sewing machine in terms of the depressing amount of the pedal increases linearly.  
1 : Reaction to intermediate speed in terms of the depressing amount of the pedal is delayed.  
2 : Reaction to intermediate speed in terms of the depressing amount of the pedal is advanced.

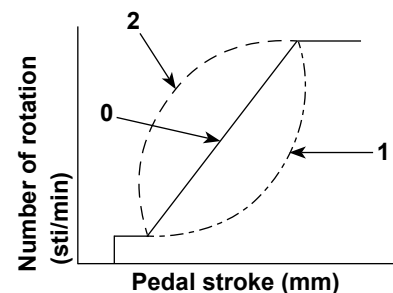





## 9. Automatic compensation of neutral point of the pedal sensor

Whenever the pedal sensor, spring, etc. are replaced, be sure to perform following operation :

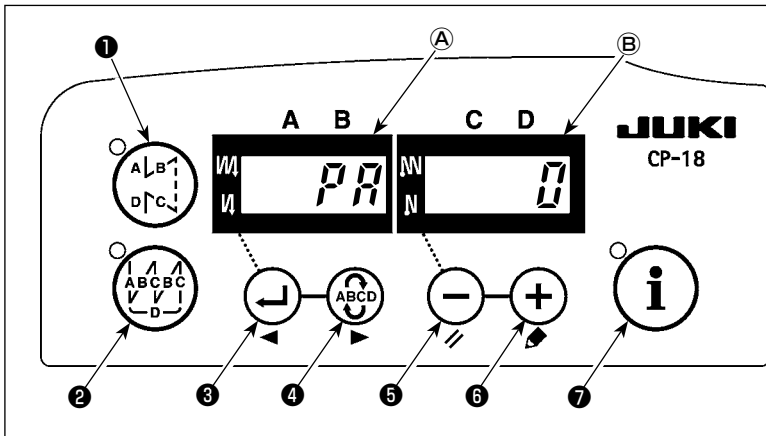

1) Pressing  switch ④ , turn ON the power switch.

2) Compensated value is displayed on indicator ② .

(Caution) 1. At this time, the pedal sensor does not work properly if the pedal is depressed. Do not place the foot or any object on the pedal. Warning sound "blips" and the correct compensation value is not displayed.

2. If any display ("-0-" or "-8-") other than a numeric value appears on indicator ② , refer to the Engineer's Manual.

3) Turn OFF the power switch, and turn ON the power switch again to return to the normal mode.

(Caution) Be sure to re-turn ON the power switch when one or more seconds have passed after turning it OFF.

(If the ON-OFF operation is carried out faster than the above, the setting may not change normally.)

## 10. Selection of the pedal specifications

When the pedal sensor has been replaced, change the set value of function setting No. 50 according to the newly connected pedal specifications.

0 : KFL

1 : PFL

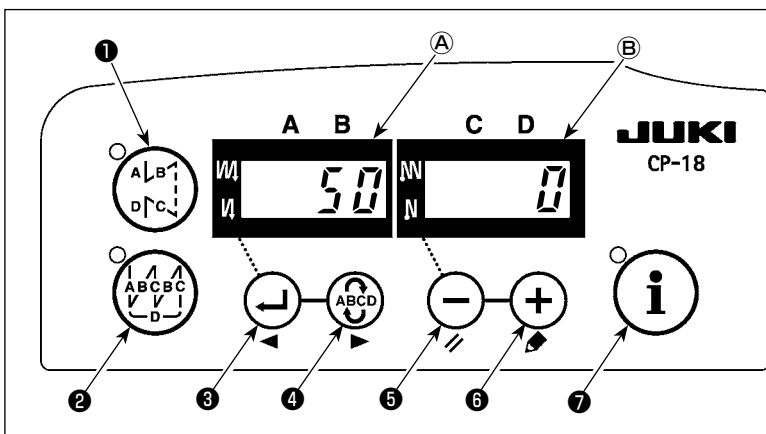

(Caution) Pedal sensor with two springs located at the back part of the pedal type is PFL, and that with one spring type is KFL. Set the pedal sensor to PFL when lifting the presser foot by depressing the back part of the pedal.

## 11. Setting of the auto lifter function



### WARNING :

When the solenoid is used with the air drive setting, the solenoid may be burned out. So, do not mistake the setting.

When the auto-lifter device (AK) is attached, this function makes the function of auto-lifter work.

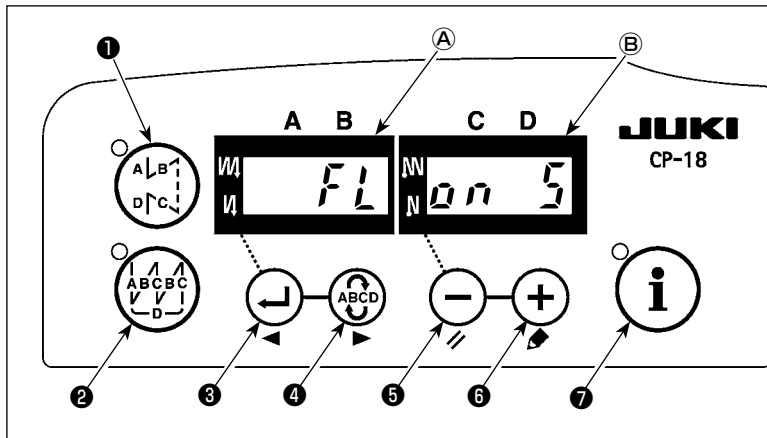

- 1) Turn ON the power switch with switch held pressed.
- 2) "FL ON" is displayed on indicators and with a blip to make the auto lifter function effective.
- 3) Turn OFF the power switch, and turn ON the power switch again to return to the normal mode.
- 4) Repeat the operation 1) to 3), and LED display is turned to "FL OFF". Then, the function of auto-lifter does not work.

FL ON : Auto-lifter device becomes effective. Selection of the auto-lifter device of solenoid drive (+33V) or of air drive (+24V) can be performed with switch . (Changeover is performed to drive power +33V or +24V of CN37.)

Solenoid drive display (+33V)

Air drive display (+24V)

FL OFF : Auto-lifter function does not work. (Similarly, the presser foot is not automatically lifted when programmed stitching is completed.)

- (Caution)**
1. To perform re-returning ON of the power, be sure to perform after the time of one second or more has passed. (If ON / OFF operation of the power is performed quickly, setting may be not changed over well.)
  2. Auto-lifter is not actuated unless this function is properly selected.
  3. When "FL ON" is selected without installing the auto-lifter device, starting is momentarily delayed at the start of sewing. In addition, be sure to select "FL OFF" when the auto-lifter is not installed since the touch-back switch may not work.

## 12. Selecting procedure of the key-lock function

Setting of the number of stitches for a pattern can be prohibited by enabling the key lock function.

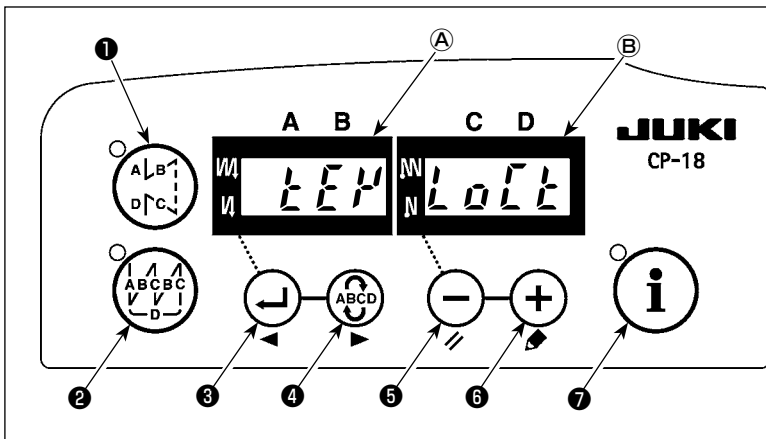

- 1) Turn ON the power switch with switch **5** and switch **6** held pressed.
- 2) "KEY LOCK" is displayed on indicators **A** and **B** with a blip to make the key-lock function effective.
- 3) The panel returns to the normal operation after displaying "KEY LOCK" on the indicators.

- 4) While the key lock function is effective, "KEY LOCK" is displayed on the indicators when turning the power ON.
- 5) When you carry out steps 1) to 3) in repetition, "KEY LOCK" is not displayed when turning the power ON and the key lock function is rendered ineffective.

- KEY LOCK display when turning the power ON

Display appears: The key lock function is effective.

Display does not appear: The key lock function is ineffective.

In the case the key lock function is effective, the operation of the panel will be as shown in the table below. (Pattern indication number)

• In the case the operation is disabled	Setting of the number of stitches for a pattern ( <b>4</b> )
• Functions that are operated in the same procedure as in the case of normal operation state	Change of the sewing pattern ( <b>1</b> and <b>2</b> ) Changeover of the reverse feed stitching ( <b>3</b> and <b>5</b> ) Production support function ( <b>7</b> )

## 13. Connection of the pedal of standing-work machine

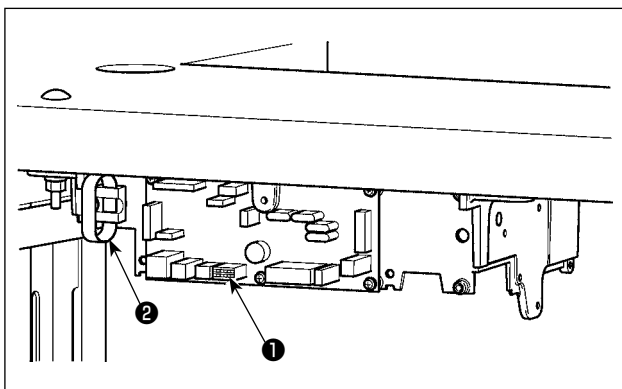

- 1) Connect the connector of PK70 to connector **1** (CN39 : 12P) of SC-920.
  - 2) Tighten the cord of PK70 together with other cords with cable clip band **2** attached to the side of the box after passing it through the cable clamp.
- (Caution)** Be sure to turn OFF the power before connecting the connector.

## 14. External input / output connector

External input/output connector (CN50) ❶ which can take out the following signals that are convenient when installing counter or the like outside is prepared.

**(Caution)** When using the connector, note that the engineer who has the electrical knowledge has to work.

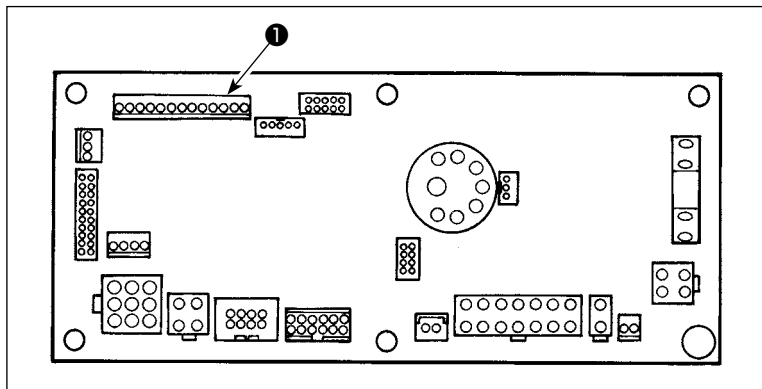

**Table of assignment of connector and signal**

CN50	Signal name	Input / output	Description	Electric spec.
1	+5V	-	Power source	
2	MA	Output	Rotation signal 360 pulses/rotation	DC5V
3	MB	Output	-	DC5V
4	UDET(N)	Output	"L" is output when needle bar is at LOW position.	DC5V
5	DDET(N)	Output	"L" is output when needle bar is at UP position.	DC5V
6	HS(N)	Output	Rotation signal 45 pulses/rotation	DC5V
7	BTD(N)	Output	"L" is output when the back-tack solenoid works.	DC5V
8	TRMD(N)	Output	"L" is output when the thread trimmer solenoid works.	DC5V
9	LSWO(P)	Output	Rotation request (pedal or the like) monitor signal	DC5V
10	S.STATE(N)	Output	"L" is output when the sewing machine is in the stop state.	DC5V
11	LSWINH(N)	Input	Rotation by pedal is prohibited while "L" signal is being inputted.	DC5V, -5mA
12	SOFT	Input	Rotation speed is limited to the soft-speed while "L" signal is being inputted.	DC5V, -5mA
13	SGND	-	0V	

JUKI genuine part No.

Connector : Part No. HK016510130

Pin contact : Part No. HK016540000

## 15. Connection of the material end sensor

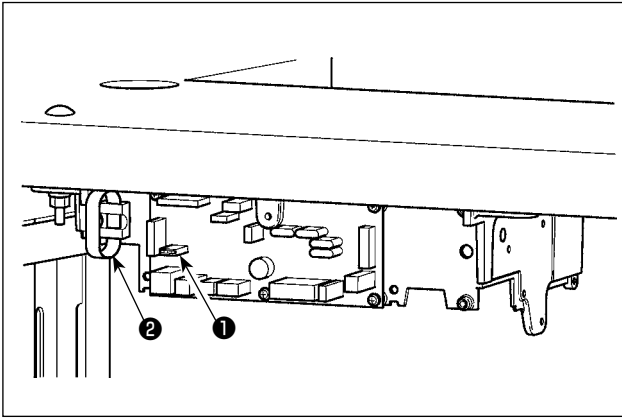

Pin No.	Signal name	Remarks
1	+12V	Power supply is selected according to the sensor used.
2	+5V	
3	OPT_S	Sensor input is assigned to the material end sensor.
4	GND	

- 1) Connect the connector of material end sensor to connector ❶ (CN54 : 4P) of SC-920.
- 2) Tighten the cord of the material end sensor together with other cords with cable clip band ❷ attached to the side of the box after passing it through the cable clamp.
- 3) Assign CN54 to the material end sensor input referring to “III-8- ❸ Selection of the optional input/output function (Function setting No. 12)” p.30.
- 4) To use the material end sensor with the CP-18, set up the sensor functions on the control box through the function setting procedure. Selectable functions and the corresponding selection numbers are as follows:

- Material end sensor function (function setting No. 2)  
The material end sensor is enabled.

2     1

0: Material end sensor is not used.

1: Material end sensor is enabled.

- Thread trimming function by means of the material end sensor (function setting No. 3)

The automatic thread trimmer is activated after the detection of the material end.

3     1

0: Automatic thread trimming is not carried out.

1: Automatic thread trimming is carried out.

- The number of stitches after the activation of the material end sensor (function setting No. 4)  
The number of stitches to be sewn until the sewing machine stops after the material end sensor has detected the material end can be specified.

4     5

Data setting range: 0 - 19 <1/stitch>

- One-shot function (function setting No. 76)

The one-shot operation until the material end is detected can be set.

7  6     0

0: One-shot operation is not carried out.

1: One-shot operation is carried out.

- (Caution)**
1. Be sure to turn OFF the power before connecting the connector.
  2. For the use of the material end sensor, refer to the Instruction Manual attached to the material end sensor.

JUKI genuine part number	Connector	HK042310040
	Pin connector	HK042340000

## 16. Initialization of the setting data

All contents of function setting of SC-920 can be returned to the standard set values.

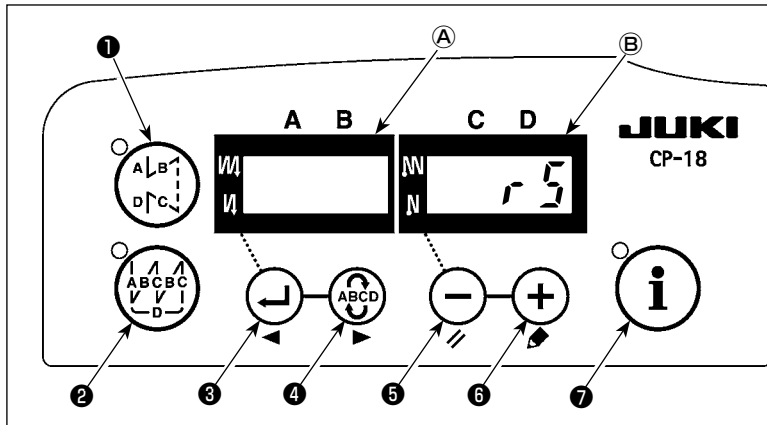

- 1) Turn ON the POWER switch with all of switch ④, switch ⑤ and switch ⑥ held pressed.
- 2) "rS" is displayed on indicator ② with a blip to start initialization.
- 3) The buzzer sounds after approximately one second (single sound three times, "peep", "peep", and "peep"), and the setting data returns to the standard setting value.

(Caution) Do not turn OFF the power on the way of initializing operation. Program of the main unit may be broken.

- 4) Turn OFF the power switch and turn ON the power switch after closing the front cover. The machine returns to the normal motion.

- (Caution) 1. When you carry out the aforementioned operation, the neutral position correction value for the pedal sensor is also initialized. It is therefore necessary to carry out automatic correction of the pedal sensor neutral position before using the sewing machine. (Refer to "III-9. Automatic compensation of neutral point of the pedal sensor" p.39.)
2. When you carry out the aforementioned operation, the machine-head adjustment values are also initialized. It is therefore necessary to carry out adjustment of the machine head before using the sewing machine. (Refer to "II-7. Adjusting the machine head (direct-drive motor type sewing machine only)" p.14.)
3. Even when this operation is performed, the sewing data set by the operation panel cannot be initialized.

## IV. MAINTENANCE

### 1. Removing the rear cover



#### WARNING :

To prevent personal injuries caused by electric shock hazards or abrupt start of the sewing machine, remove the cover after turning OFF the power switch and a lapse of 5 minutes or more. To prevent personal injuries, when a fuse has blown out, be sure to replace it with a new one with the same capacity after turning OFF the power switch and removing the cause of the blown-out of the fuse.

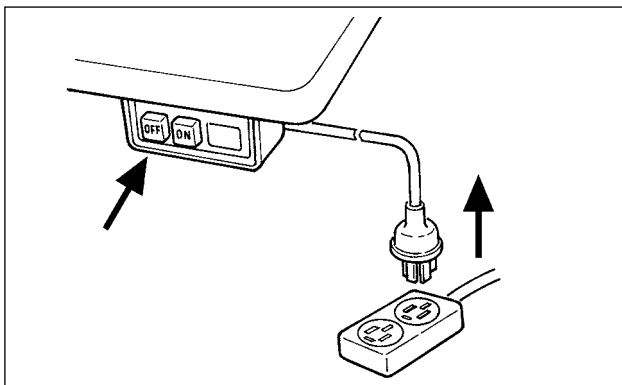

- 1) Press the OFF button of the power switch to turn OFF the power after confirming that the sewing machine has stopped.
- 2) Draw out the power cord coming from the power plug socket after confirming that the power switch is turned OFF. Perform the work of step 3) after confirming that the power has been cut and it has passed for 5 minutes or more.

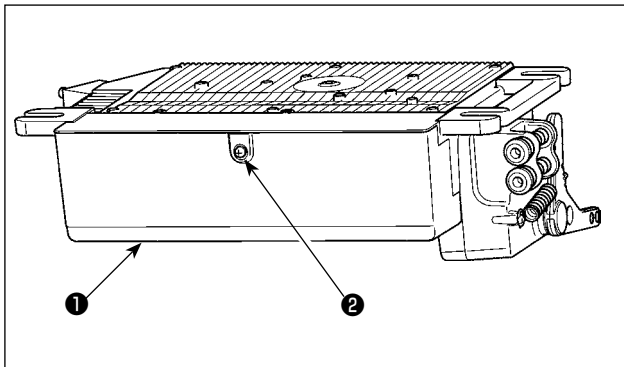

3) Loosen setscrew ② in cover ① . Open cover ① .

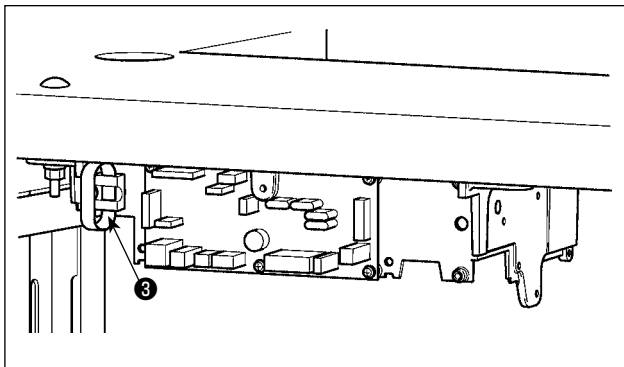

4) To close cover ① , re-tighten setscrew ② while paying attention to the orientation of cable clip band ③ mounted on the side face of the box.

## 2. Replacing the fuse

### (1) PWR PCB

(Caution) The illustration below shows the PWR-T PCB. The type of PCB differs by destination.

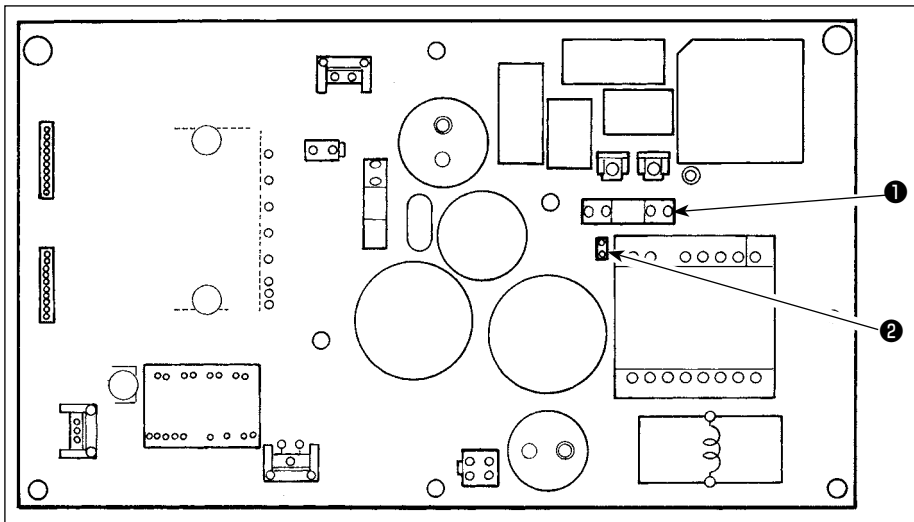

- 1) Remove all the cables which are connected to the control box.
- 2) Remove the connecting rod.
- 3) Remove the control box from the table stand.
- 4) Holding the glass section of fuse ① , remove the fuse.

(Caution) There is a risk of electrical shock when removing the fuse. Be sure to remove the fuse after LED ② has totally gone out.

5) Be sure to use a fuse with the designated capacity.

① : 6.3 A/250 V Time-lag fuse (Power circuit protective fuse)

Part number: KF000000080

6) Install the control box on the table stand. (Refer to “II-2. Installing to the table” p.3.)

7) Connect all the cables to the control box. (Refer to “II-4. Connecting the cords” p.6.)

8) Fit the connecting rod back in place. (Refer to “II-5. Attaching the connecting rod” p.12.)

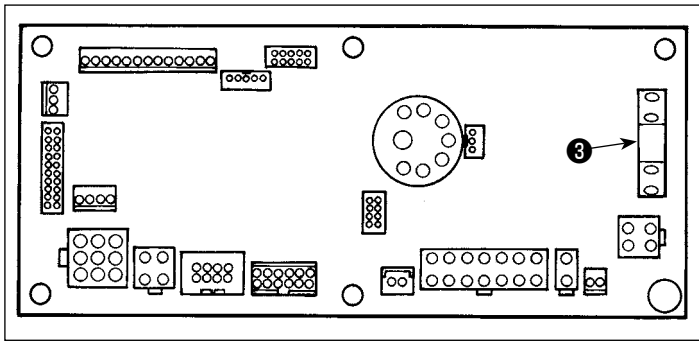

## (2) CTL PCB

- 1) Open the cover of the control box.
- 2) Pick up the glass section of fuse ③ mounted on the CTL PCB with fingers to remove it.

**(Caution)** In order to protect against the possibility of electric shock, it is necessary to remove the fuse after LED ② of the PWR PCB has totally gone off.

- 3) Be sure to use a fuse with the designated capacity.  
 ③ : 6.3 A/250 V Time-lag fuse (Solenoid power circuit protection fuse)  
 Part number: KF00000030
- 4) Close the cover of the control box.

## 3. Error codes

In case of the following, check again before you judge the case as trouble.

Phenomenon	Cause	Corrective measure
When tilting the sewing machine, the buzzer beeps and the sewing machine cannot be operated. Solenoids for thread trimming	When tilting the sewing machine without turning OFF the power switch, Action given on the left side is taken for safety sake.	Tilt the sewing machine after turning OFF the power.
Solenoids for thread trimming, reverse feed, wiper, etc. fail to work. Hand lamp does not light up.	When the fuse for solenoid power protection has blown out	Check the fuse for solenoid power protection.
Even when depressing the pedal immediately after turning ON the power, the sewing machine does not run. When depressing the pedal after depressing the back part of pedal once, the sewing machine runs.	Neutral position of the pedal has varied. (Neutral position may be shifted when changing spring pressure of the pedal or the like.)	Execute the automatic neutral correction function of the pedal sensor.
The sewing machine does not stop even when the pedal is returned to its neutral position.		
Stop position of the sewing machine varies (irregular).	When tightening the screw in the hand-wheel is forgotten at the time of adjustment of needle stop position.	Securely tighten the screw in the handwheel.
Presser foot does not go up even when auto-lifter device is attached.	Auto-lifter function is OFF.	Select "FL ON" by auto-lifter function selection.
	Pedal system is set to KFL system.	Change the jumper to PFL setting to lift the presser foot by depressing the back part of the pedal.
	Cord of auto-lifter device is not connected to connector (CN37).	Connect the cord properly.
Touch-back switch fails to work.	Presser foot is going up by auto-lifter device.	Operate the switch after the presser foot lowered.
	Auto-lifter device is not attached. However, auto-lifter function is ON.	Select "FL OFF" when auto-lifter device is not attached.
UP position move fails to work when all lamps on the panel light up.	The mode is in the function setting mode. The switch on the CTL p.c.b. is pressed by the bound cords and the aforementioned mode resulted.	Remove the under cover. Bundle the cables by routing them according to the normal routing method as described in the Instruction Manual.
Sewing machine fails to run.	Motor output cord (4P) is disconnected.	Connect the cord properly.
	Connector (CN30) of motor signal cord is disconnected.	Connect the cord properly.



In addition, there are the following error codes in this device. These error codes interlock (or limit function) and inform the problem so that the problem is not enlarged when any problem is discovered. When you request our service, please confirm the error codes.

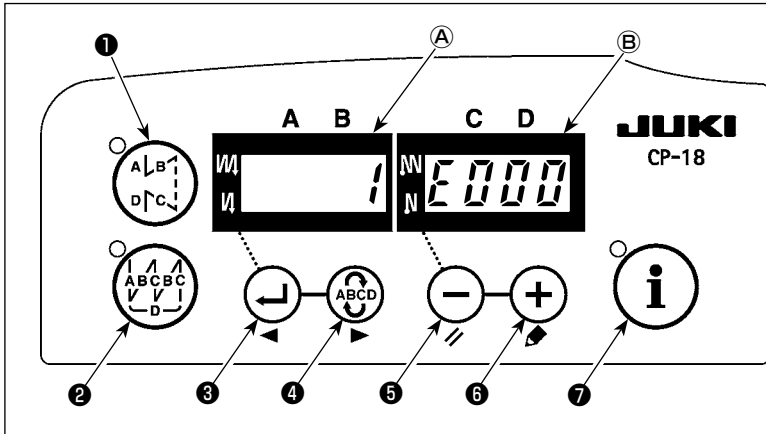

**[Checking procedure of the error code]**

- 1) Turn ON the power switch with switch ① held pressed.
- 2) The latest error number is displayed on indicator ② with a blip.
- 3) Contents of previous errors can be checked by pressing switch ③ or switch ④. (When the confirmation of the contents of previous error advanced to the last, the warning sound peeps in single tone two times.)

(Caution) When switch ③ is pressed, the previous error code of the currently displayed one is displayed.

When switch ④ is pressed, the next error code of the currently displayed one is displayed.

**Error code list**

No.	Description of error detected	Cause of occurrence expected	Items to be checked
-	Media cover open	• Cover of the slot of media is open.	• Close the cover.
E000	Execution of data initialization (This is not the error.)	• When the machine head is changed. • When the initialization operation is executed.	
E003	Disconnection of synchronizer connector	• When position detection signal is not input from the sewing machine head synchronizer.	• Check the synchronizer connector (CN33) for loose connection and disconnection.
E004	Synchronizer lower position sensor failure	• When the synchronizer has broken.	• Check whether the synchronizer cord has broken since the cord is caught in the machine head.
E005	Synchronizer upper position sensor failure	• Belt is loose. • Machine head is not proper. • Motor pulley is not proper.	• Check the belt tension. • Check the setting of the machine head. • Check the setting of the motor pulley.
E007	Overload of motor	• When the machine head is locked. • When sewing extra-heavy material beyond the guarantee of the machine head. • When the motor does not run. • Motor or driver is broken.	• Check whether the thread has been entangled in the motor pulley. • Check the motor output connector (4P) for loose connection and disconnection. • Check whether there is any holdup when turning the motor by hand.
E011(*)	Media is not inserted.	• Media is not inserted.	• Turn the power OFF and check the media.
E012(*)	Read error	• Data of media cannot be read.	• Turn the power OFF and check the media.
E013(*)	Write error	• Data of media cannot be written.	• Turn the power OFF and check the media.
E014(*)	Write protect	• Media is in the state of writing prohibition.	• Turn the power OFF and check the media.
E015(*)	Format error	• Formatting cannot be performed.	• Turn the power OFF and check the media.
E016(*)	External media capacity over	• Capacity of media is short.	• Turn the power OFF and check the media.
E019(*)	File size over	• File is too large.	• Turn the power OFF and check the media.
E032(*)	File interchangeability error	• There is no interchangeability of file.	• Turn the power OFF and check the media.
E041(*)	Sewing recorder error	• This error number is displayed in the event of a sewing recorder data fault.	• Check whether the data has any fault.

\* The error number attached with an asterisk (\*) is displayed only in the case a fault occurs when the IP/IT panel is connected to the sewing machine.

No.	Description of error detected	Cause of occurrence expected	Items to be checked
E044(*)	Date and time error	<ul style="list-style-type: none"> <li>This error number is displayed in the event of operation/data fault concerning date or time of day.</li> </ul>	<ul style="list-style-type: none"> <li>Check whether the data has any fault.</li> </ul>
E053(*)	Notification of production support function initialization (This is not an error)	<ul style="list-style-type: none"> <li>This error number is displayed after the execution of initialization of the production support function or upgrading of the program.</li> </ul>	
E055(*)	Production management error	<ul style="list-style-type: none"> <li>This error number is displayed in the event of production management work management data fault.</li> </ul>	<ul style="list-style-type: none"> <li>Check whether the data has any fault.</li> </ul>
E056(*)	Work management error	<ul style="list-style-type: none"> <li>This error number is displayed in the event of data fault.</li> </ul>	<ul style="list-style-type: none"> <li>Check whether the data has any fault.</li> </ul>
E057(*)	Pitch time monitor error	<ul style="list-style-type: none"> <li>This error number is displayed in the event of pitch time monitor data fault.</li> </ul>	<ul style="list-style-type: none"> <li>Check whether the data has any fault.</li> </ul>
E065(*)	Network transmission failed	<ul style="list-style-type: none"> <li>This message is displayed in the case data cannot be sent to the personal computer by way of the network.</li> </ul>	<ul style="list-style-type: none"> <li>Check whether the network has any fault.</li> </ul>
E067(*)	ID reading failed	<ul style="list-style-type: none"> <li>This message is displayed in the case data in the ID file is broken.</li> </ul>	<ul style="list-style-type: none"> <li>Check whether the data has any fault.</li> </ul>
E070	Slip of belt	<ul style="list-style-type: none"> <li>When the machine head is locked.</li> <li>Belt is loose.</li> </ul>	<ul style="list-style-type: none"> <li>Check whether there is any holdup when turning the motor by hand.</li> <li>Check the belt tension.</li> </ul>
E071	Disconnection of motor output connector	<ul style="list-style-type: none"> <li>Disconnection of motor connector.</li> </ul>	<ul style="list-style-type: none"> <li>Check the motor output connector for loose connection and disconnection.</li> </ul>
E072	Overload of motor at the time of thread trimming motion	<ul style="list-style-type: none"> <li>Same as E007.</li> </ul>	<ul style="list-style-type: none"> <li>Same as E007.</li> </ul>
E204(*)	USB insertion	<ul style="list-style-type: none"> <li>This message is displayed in the case the sewing machine is activated with the USB thumb drive inserted.</li> </ul>	<ul style="list-style-type: none"> <li>Remove the USB thumb drive.</li> </ul>
E205(*)	Warning of ISS buffer remaining amount	<ul style="list-style-type: none"> <li>This message is displayed in the case the buffer storage for storing the ISS data is almost full. If the sewing machine is continuously used with the buffer storage full, the stored pieces of data will be erased from the earliest one.</li> </ul>	<ul style="list-style-type: none"> <li>Output the data.</li> </ul>
E220	Grease-up warning	<ul style="list-style-type: none"> <li>When the predetermined number of stitches has been reached.</li> </ul>	<ul style="list-style-type: none"> <li>Replenish the specified places with grease and reset. (For the details, refer to the data of the machine head.)</li> </ul>
E221	Grease-up error	<ul style="list-style-type: none"> <li>When the predetermined number of stitches has been reached and the sewing is not possible.</li> </ul>	<ul style="list-style-type: none"> <li>Replenish the specified places with grease and reset. (For the details, refer to the data of the machine head.)</li> </ul>
E302	Fall detection switch failure (When the safety switch works)  (Thread trimming knife sensor)	<ul style="list-style-type: none"> <li>When fall detection switch is input in the state that the power is turned ON.</li> <li>Machine-head tilt detector's connector has come off.</li> <li>Thread trimming knife position is not correct.</li> </ul>	<ul style="list-style-type: none"> <li>Check whether the machine head is tilted without turning OFF the power switch (sewing machine operation is prohibited for safety sake).</li> <li>Check whether the fall detection switch cord is caught in the sewing machine or the like.</li> <li>Check whether the fall detection switch lever is caught in something.</li> <li>Check whether the contact of the tilt detection switch lever with the machine table is inadequate. (The table has a dent or the mounting location of the bed strut is too far)</li> <li>Check the machine-head tilt detector's connector (CN48) for looseness and slip-off.</li> <li>Positioning of the thread trimming sensor</li> <li>Set the function setting No. 74 to 0 (zero) when the thread trimmer is not installed on the sewing machine.</li> </ul>

\* The error number attached with an asterisk (\*) is displayed only in the case a fault occurs when the IP/IT panel is connected to the sewing machine.

No.	Description of error detected	Cause of occurrence expected	Items to be checked
E303	Semicircular plate sensor error	<ul style="list-style-type: none"> <li>Semicircular plate sensor signal cannot be detected.</li> </ul>	<ul style="list-style-type: none"> <li>Check whether the machine head corresponds with the machine type setting.</li> <li>Check whether the motor encoder connector is disconnected.</li> </ul>
E499	Simplified program data fault	<ul style="list-style-type: none"> <li>Command parameter data is out of specified range.</li> </ul>	<ul style="list-style-type: none"> <li>Re-enter the relevant simplified program.</li> <li>Set the simplified program in disable.</li> </ul>
E703(*)	Operation panel is connected to the unexpected sewing machine. (Error of sewing machine model)	<ul style="list-style-type: none"> <li>The operation panel and the sewing machine model do not match in the initial communication.</li> </ul>	<ul style="list-style-type: none"> <li>Connect the operation panel to the correct model of the sewing machine.</li> </ul>
E704(*)	System version mismatch	<ul style="list-style-type: none"> <li>The system version is different from the correct one in the initial communication.</li> </ul>	<ul style="list-style-type: none"> <li>Re-write the system version to the one that can be used with the operation panel.</li> </ul>
E730	Encoder failure	<ul style="list-style-type: none"> <li>When the motor signal is not properly inputted.</li> </ul>	<ul style="list-style-type: none"> <li>Check the motor signal connector (CN30) for loose connection and disconnection.</li> <li>Check whether the motor signal cord has broken since the cord is caught in the machine head.</li> <li>Check whether the inserting direction of the motor encoder connector is wrong.</li> </ul>
E731	Motor hole sensor failure		
E733	Inverse rotation of motor	<ul style="list-style-type: none"> <li>This error occurs when the motor is running at 500 sti/min or more in the opposite direction of that of rotation indication during motor is running.</li> </ul>	<ul style="list-style-type: none"> <li>Check whether the machine head corresponds with the machine type setting.</li> <li>Check whether the main-shaft motor encoder wire is connected incorrectly.</li> <li>Check whether the main-shaft motor wire for power supply is connected incorrectly.</li> </ul>
E799	Thread trimming operation time-out	<ul style="list-style-type: none"> <li>The thread trimming control operation is not completed within the predetermined time (within three seconds).</li> </ul>	<ul style="list-style-type: none"> <li>Check whether the machine head actually installed is different from the machine head selection.</li> <li>Check whether the motor-pulley diameter does not match its setting (effective diameter).</li> <li>Check whether the belt has slackened.</li> </ul>
E808	Solenoid short circuit	<ul style="list-style-type: none"> <li>Solenoid power does not become normal voltage.</li> </ul>	<ul style="list-style-type: none"> <li>Check whether the machine head cord is caught in the pulley cover or the like.</li> </ul>
E809	Holding motion failure	<ul style="list-style-type: none"> <li>Solenoid is not changed over to holding motion.</li> </ul>	<ul style="list-style-type: none"> <li>Check whether the solenoid is abnormally heated. (CTL circuit board asm. Circuit is broken.)</li> </ul>
E810	Solenoid current abnormality	<ul style="list-style-type: none"> <li>Solenoid rare short-circuit.</li> </ul>	<ul style="list-style-type: none"> <li>Solenoid resistance.</li> </ul>
E811	Abnormal voltage	<ul style="list-style-type: none"> <li>When voltage higher than guaranteed one is inputted.</li> <li>200V has been inputted to SC-920 of 100V specifications.</li> <li>JA : 220V is applied to 120V box.</li> <li>CE : 400V is applied to 230V box.</li> </ul>	<ul style="list-style-type: none"> <li>Check whether the applied power voltage is higher than the rated voltage + (plus) 10% or more.</li> <li>Check whether 100V/200V changeover connector is improperly set.</li> </ul> <p>In the aforementioned cases, POWER p.c.b is broken.</p>
		<ul style="list-style-type: none"> <li>When voltage lower than guaranteed one is inputted.</li> <li>100V has been inputted to SC-920 of 200V specifications.</li> <li>JA : 120V is applied to 220V box</li> <li>Inner circuit is broken by the applied overvoltage</li> </ul>	<ul style="list-style-type: none"> <li>Check whether the voltage is lower than the rated voltage - (minus) 10% or less.</li> <li>Check whether 100V/200V changeover connector is improperly set.</li> <li>Check whether fuse or regenerative resistance is broken.</li> </ul>
E906	Operation panel transmission failure	<ul style="list-style-type: none"> <li>Disconnection of operation panel cord.</li> <li>Operation panel has broken.</li> </ul>	<ul style="list-style-type: none"> <li>Check the operation panel connector (CN38) for loose connection and disconnection.</li> <li>Check whether the operation panel cord has broken since the cord is caught in the machine head.</li> </ul>
E924	Motor driver failure	<ul style="list-style-type: none"> <li>Motor driver has broken.</li> </ul>	
E942	Faulty EEPROM	<ul style="list-style-type: none"> <li>Data cannot be written on the EEPROM.</li> </ul>	<ul style="list-style-type: none"> <li>Turn the power OFF.</li> </ul>

\* The error number attached with an asterisk (\*) is displayed only in the case a fault occurs when the IP/IT panel is connected to the sewing machine.