

CHAPTER I

Mechanical section



CONTENTS

I . Mechanical section

1. SPECIFICATIONS	I - 1
(1) Specifications	I - 1
(2) Shapes of buttons	I - 2
1) Specifications for 4-holed and 2-holed buttons	I - 2
2) Specifications for shank button and marble button	I - 2
3) Specifications for stay button	I - 3
4) Counter button specifications	I - 3
(3) Configuration	I - 4
2. INSTALLATION	I - 5
(1) Set-up of the table	I - 5
(2) Connecting the power source cord	I - 6
1) Voltage specifications	I - 6
2) Connecting single phase 200V, 220V, 230V and 240V	I - 6
3) Connecting three phase 200V, 220V and 240V	I - 6
(3) Changing the voltage of 100 / 200V	I - 7
(4) Installing the sewing machine main unit	I - 8
(5) Tilting the sewing machine head	I - 8
(6) Removing the fixed plate for transport	I - 9
(7) Installing the operation panel	I - 9
(8) Installing the air regulator	I - 10
(9) Connecting the cords	I - 11
(10) Managing the cord	I - 12
(11) Installing the eye protection cover and the finger guard	I - 12
(12) Installing the thread stand	I - 13
(13) Attaching the button tray	I - 13
3. PREPARATION BEFORE OPERATION	I - 14
(1) Inserting the needle	I - 14
(2) Threading the needle-thread	I - 14
(3) Adjusting the stay (counter) button stopper	I - 15
(4) Replacing the button chuck	I - 16
(5) Set of the button neck wrapping	I - 17
(6) Set of the sewing flat button with blindstitch	I - 17
4. ADJUSTMENT OF THE SEWING MACHINE	I - 18
(1) Adjusting the needle and the looper	I - 18
1) Adjusting the needle bar height	I - 18
2) Adjusting the clearance between the needle and the looper	I - 18
(2) Adjusting the position of the york slide	I - 19
(3) Adjusting the needle and the needle guide	I - 20
1) Adjusting the position of the needle and the throat plate.....	I - 20
2) Adjusting the clearance between the needle and the needle guide	I - 20

(4) Adjusting the thread trimmer mechanism.....	I - 21
1) Adjusting the position of the moving knife	I - 21
2) Adjusting the moving knife thread separation nail	I - 21
(5) Adjusting the wiper mechanism.....	I - 22
(6) Adjusting the chuck open mechanism.....	I - 22
5. MAINTENANCE.....	I - 23
(1) Replacing the attachments.....	I - 23
1) Replacing the button set pin (optional).....	I - 23
2) Replacing the carrier pin	I - 23
3) Replacing the tongue stopper	I - 24
(2) Replacing the fuse.....	I - 25
(3) Greasing parts	I - 26
6. AIR CIRCUIT DIAGRAM.....	I - 28
7. DRAWING OF THE TABLE	I - 29
(1) Table.....	I - 29
(2) Auxiliary table	I - 30

I . Mechanical section

1. SPECIFICATIONS

(1) Specifications

Model	AMB-289
Name of model	Computer-controlled, high-speed, single-thread, chainstitch, button-neck-wrapping machine
Application	Various buttons sewing (Buttons which can be sewn with the sewing machine)
Feature	The machine comes standard with plural sewing patterns by computer-controlled feed, needle throwing, thread tension and thread trimmer. It can perform efficiently high-quality button sewing and a multipurpose button sewing machine that can be used as the general machine.
Sewing speed	Max. 1,800 sti/min (buttons with neck wraps), 1,200 sti/min (button sewing) Normal speed 1,500 sti/min (buttons with neck wraps), 1,000 sti/min (button sewing)
Button size	Sewing buttons without button neck : 8 mm to 38 mm Sewing buttons with neck wraps : Max. 32 mm Counter button : 8 mm to 25 mm Counter button neck wrapping : Total of material and front button is up to 32 mm.
Needle	SM332EXTLG-NY (Standard) #12 to #18
Thread take-up lever	Needle bar thread take-up lever : Stroke 60 mm
Needle throwing method	Stepping motor drive
Feed method	Stepping motor drive
Presser lifting method	Stepping motor drive
Cloth presser method	Air drive
Thread trimmer method	Air drive
Thread tension adjustment	Active tension (VCM) method
Dimensions	Width : 600 x Height : 400 x Length : 600 (mm)
Weight of head	65kg
Number of data that can be stored in memory	Max. 99 patterns
Number of times of cycle sewing	Number of registered patterns : 20 patterns (1 cycle 30 patterns)
Basic shape setting range	Interval between buttonholes : 1.5 to 6.0 mm (in increments of 0.1 mm) Height of neck wraps : 0, 1.5 to 10.0 mm (in increments of 0.1 mm) Number of crossover threads : 2 to 64 threads (in increments of 2 threads)
Pattern selection	Pattern No. designation method (scroll 1 to 99 patterns)
Memory backup	Pattern data, sewing data, cycle sewing data
Sewing count	Number of times of sewing count method (0 to 9999) up/down Sewing counter is possible.
Power requirements	Single phase 200V, 220V, 230V and 240V, Three phase 200V, 220V and 240V 400VA
Noise	- Equivalent continuous emission sound pressure level (L _{pA}) at the workstation : A-weighted value of 77.0 dB; (Includes K _{pA} = 2.5 dB); according to ISO 10821- C.6.3 -ISO 11204 GR2 at 1,800 sti/min.

(2) Shapes of buttons

1) Specifications for 4-holed and 2-holed buttons

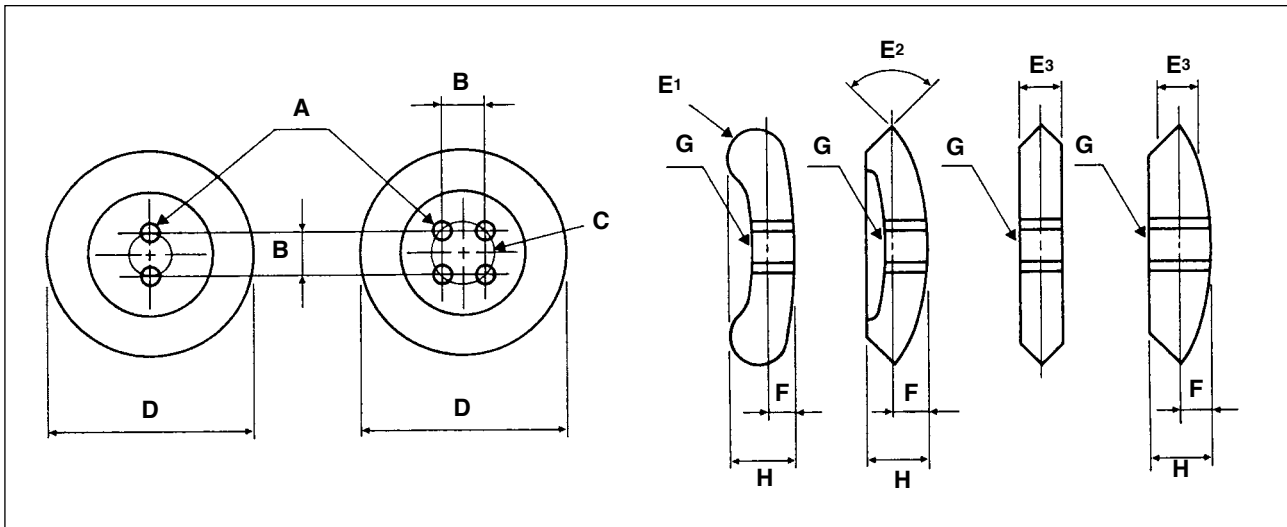

A : Buttonhole diameter	Needle used : ϕ 1.5 mm or more when using #12 to #16 Needle used : ϕ 2 mm or more when using #16 to #18
B : Distance between buttonholes	1.5 to 6.0 mm (in increments of 0.1 mm)
C : Location of buttonholes	All holes must be located equidistant from the center of each button.
D : Outside diameter	Min. outside diameter : ϕ 8 mm Max. outside diameter : ϕ 32 mm Line height : within \pm 0.25 mm
E ¹ : Button with a round edge	R (roundness) of button edge must be a 3 mm radius or less.
E ² : Button with a V-shaped edge	Within 120° angle
E ³ : Button with an angular edge	The thickness must be 5 mm or less.
F : Bulge	5 mm or less
G : Area around buttonholes	Must be smooth
H : Thickness of button	8 mm or less

2) Specifications for shank button and marble button

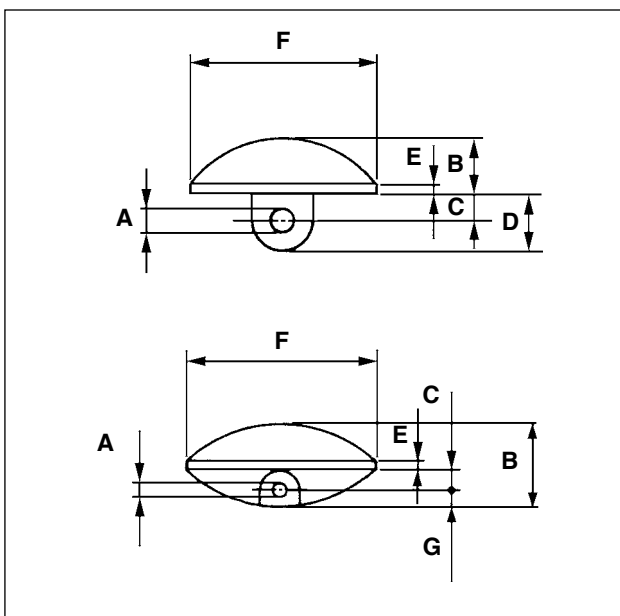

A : Buttonhole diameter	ϕ 1.5 mm or more
B : Thickness of button	6.8 mm or less
C : Distance from the bottom of the button head to the center of the buttonhole	Shank button : 1 mm to 6 mm Marble button : 1.5 mm or more
D : Length of shank	8 mm or less
E : Height of the straight section on the side face of button	3.5 mm or less
F : Outside diameter	Min. outside diameter: ϕ 8 mm Max. outside diameter: ϕ 32 mm
G : Distance from the center of the hole to the button edge	2 mm or less



When the button loader is used, there are cases where the buttons cannot be used due to the shape. So, be careful.

3) Specifications for stay button

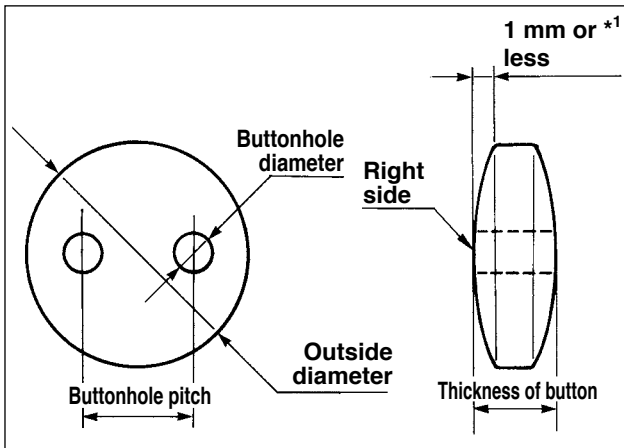

Commendable dimension

	Outside diameter	Buttonhole diameter	Buttonhole pitch	Thickness of button
Type A	8.5mm	2.5mm	3.1mm	2.0mm
Type B	10.2mm	3.2mm	4.0mm	2.0mm

*1 For the stay buttons, use those, the amount of convex on the right side of which is 1 mm or less.

4) Counter button specifications

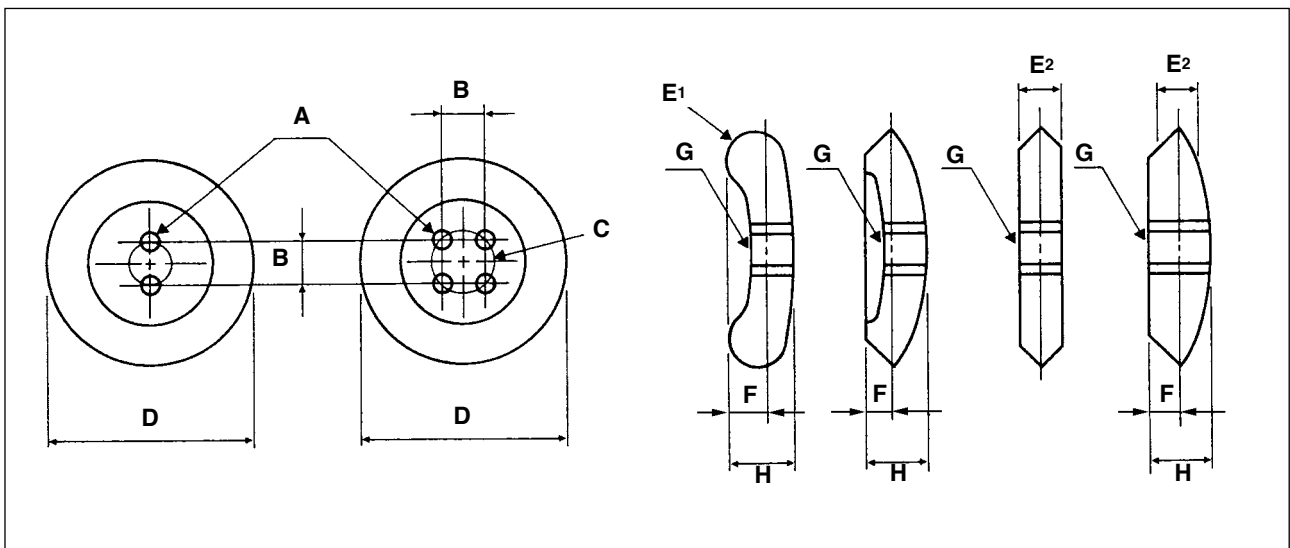

Commendable dimension

A : Buttonhole diameter	Needle used : ϕ 1.5 mm or more when using #12 to #16 Needle used : ϕ 2 mm or more when using #16 to #18
B : Distance between buttonholes	1.5 to 6.0 mm
C : Location of buttonholes	All holes must be located equidistant from the center of each button.
D : Outside diameter	Min. outside diameter : ϕ 8 mm Max. outside diameter : ϕ 25 mm
E ¹ : Button with a round edge	R (roundness) of button edge must be a 2 mm radius or less.
E ² : Button with an angular edge	The thickness must be 5 mm or less.
F : Height of button edge	2 mm or less
G : Area around buttonholes	Must be smooth
H : Thickness of button	5 mm or less

(3) Configuration

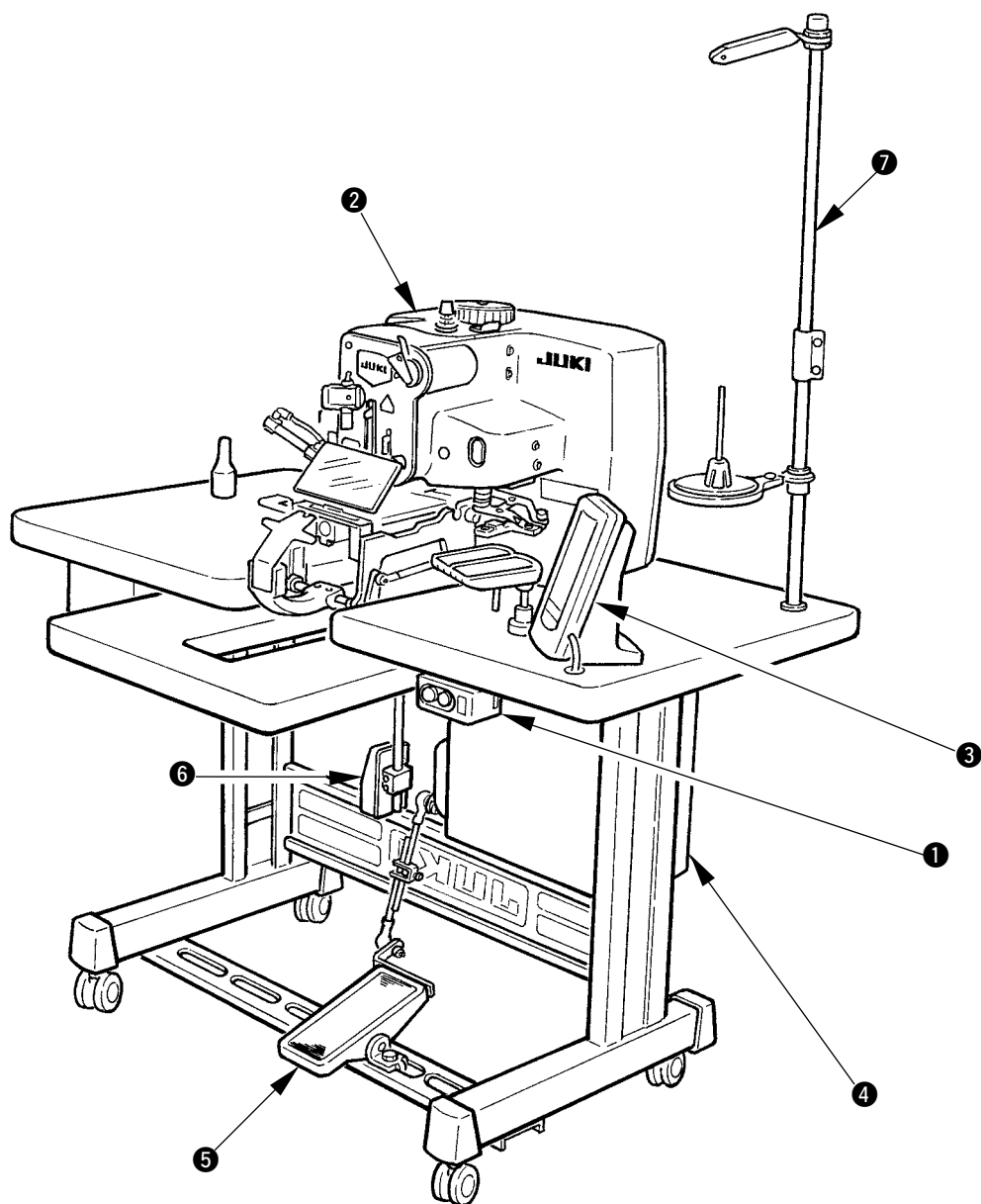

AMB-289 consists of the following components.

①	Power ON/OFF switch
②	Machine head (AMB-289)
③	Operation panel (IP-310D)
④	Control box (MC-640)
⑤	Foot pedal
⑥	Start switch
⑦	Thread stand device

2. INSTALLATION



WARNING :

To prevent possible accidents caused by the fall of the sewing machine, perform the work by two persons or more when the machine is moved.

(1) Set-up of the table

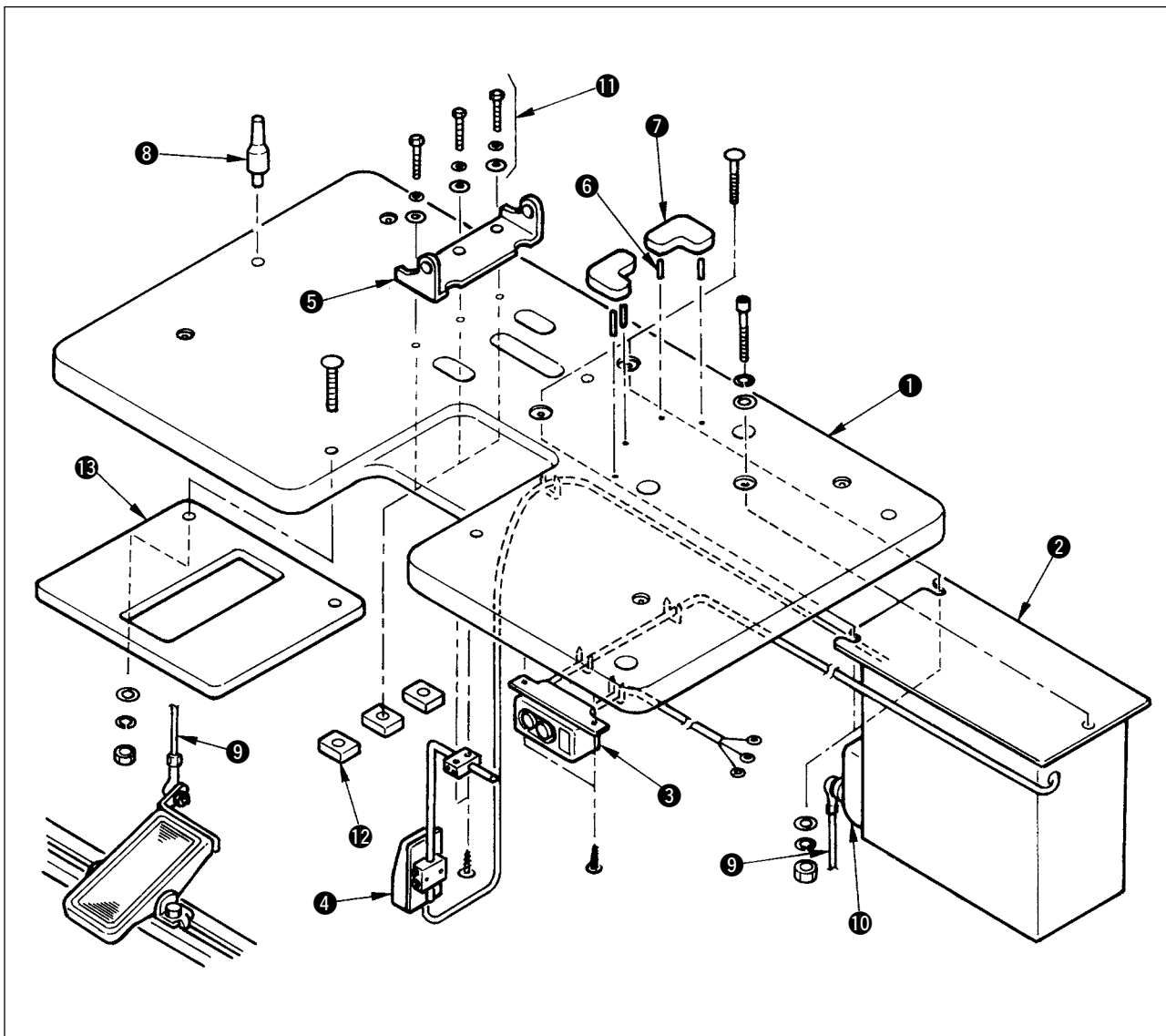

1) Fix control box ②, power switch ③, auxiliary table ⑬ and start switch ④ to table ①.

Note) Install auxiliary table ⑬ before installing start switch ④.

2) Fix the cables of power switch ③ and start switch ④ with staples.

3) Pass arm stay fixing screws ⑪ (3 pcs.) through arm stay ⑤, instal on the table, and fix them with nuts ⑫.

4) Drive pins ⑥ to the table, and insert rubber cushions ⑦.

5) Fix head support bar ⑧ on table ①.

6) Connect the pedal (left-hand side) and control box pedal sensor ⑩ with connecting rod ⑨ supplied as accessories.



Adjust the positions of the pedals so that connecting rods ⑨ and control box ② do not come in contact with each other.

(2) Connecting the power source cord

1) Voltage specifications

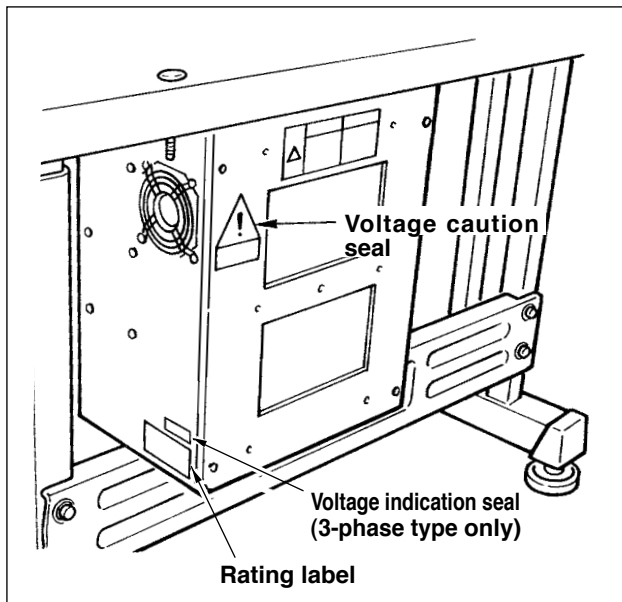

Power source specifications are indicated on the voltage indication seal. (3-phase type only)

For other type machines, power source specifications are indicated on the voltage caution seal and the rating label.

Connect the cord in accordance with the specifications.

2) Connecting single phase 200V, 220V, 230V and 240V

Connect so as to supply the power to the white wire and the black wire as shown in the illustration.

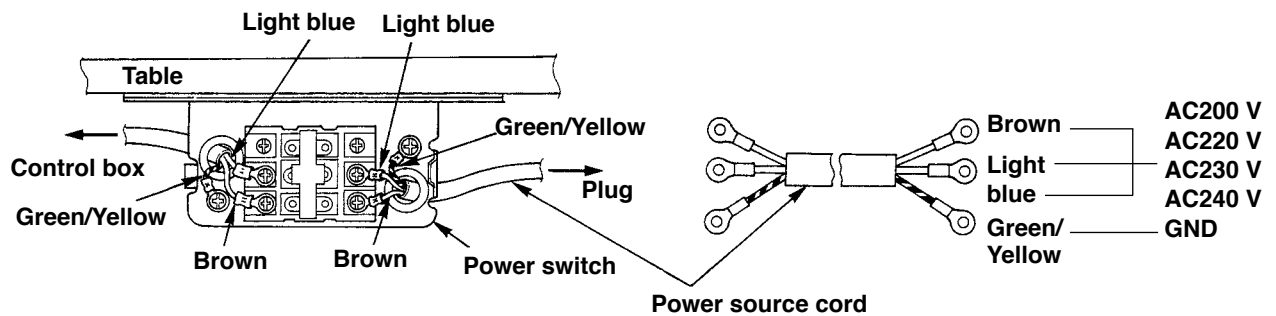

3) Connecting three phase 200V, 220V and 240V

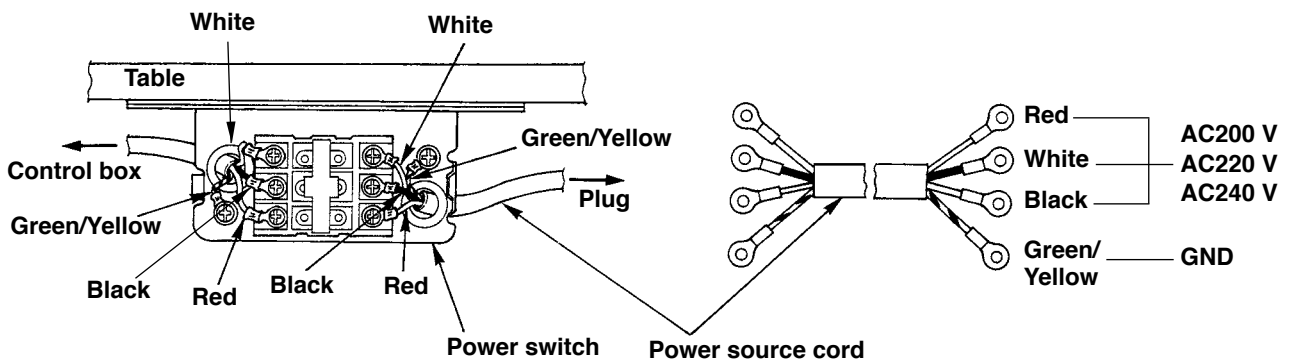

1. Never use under the wrong voltage and phase.
2. When changing the voltage, refer to the item of "Changing the voltage of 100 / 200V".

(3) Changing the voltage of 100 / 200V



WARNING :

To prevent personal injuries caused by electric shock hazards or abrupt start of the sewing machine, carry out the work after turning OFF the power switch and a lapse of 5 minutes or more. To prevent accidents caused by unaccustomed work or electric shock, request the electric expert or engineer of our dealers when adjusting the electrical components.

It is adaptable to the voltage of single phase 100V to 120V/3-phase 200V to 240V by changing the voltage changeover connector mounted on FLT p.c.b.

(Caution) When the changing procedure is wrong, the control box will be broken. So, be very careful.

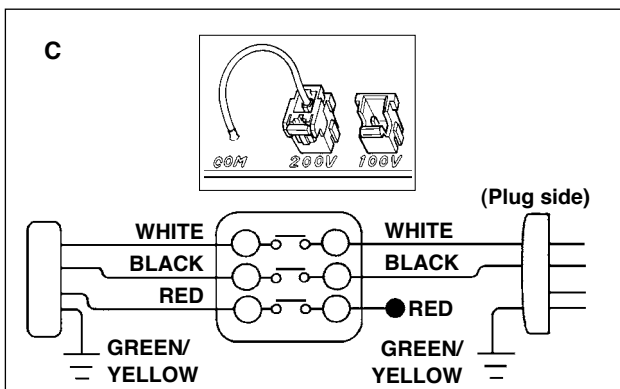
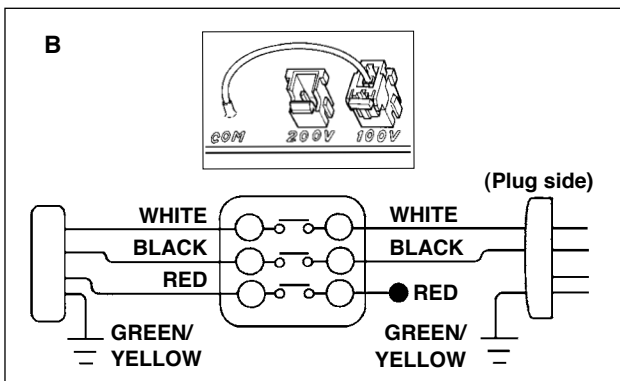
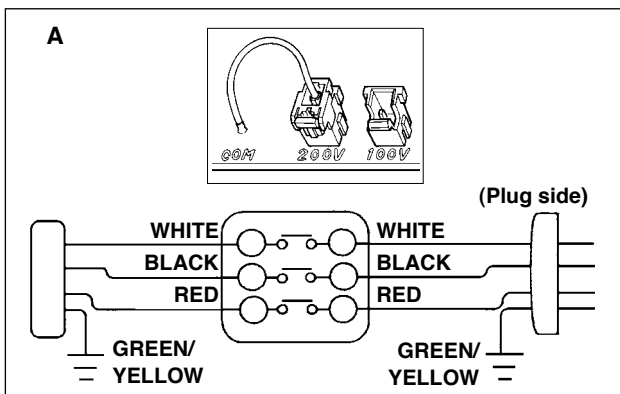
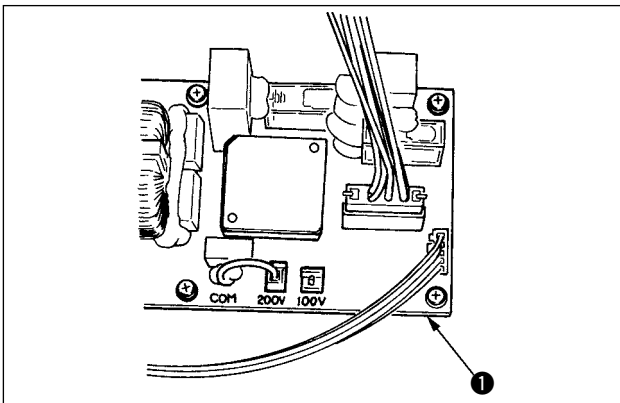

Changing procedure of the changeover connector

1. Turn OFF the power source with the power switch after confirming that the sewing machine has stopped.
2. Draw out the power cord from the power plug socket after confirming that the power switch is turned OFF. Then wait for five minutes or more.
3. Remove the front cover.
4. Remove four screws fixing the rear cover of the control box and slowly open the rear cover.

A. In case of using with 3-phase 200V to 240V

- Changing the changeover connector
Connect to 200V the 100/200V changeover connector of FLT p.c.b. ❶ located on the side of the Box Side of the control box.
- Connect the crimp style terminal of AC input cord to the power plug as shown in the figure.

B. In case of using with single phase 100V to 120V

- Changing the changeover connector
Connect to 100V the 100/200V changeover connector of FLT p.c.b. ❶ located on the side of the Box Side of the control box.
- Connect the crimp style terminal of AC input cord to the power plug as shown in the figure.

(Caution) Securely perform the insulation treatment to the red terminal which is not used with insulation tape or the like. (When the insulation is insufficient, there is a danger of electric shock or leakage current.)

C. In case of using with single phase 200V to 240V

- Changing the changeover connector
Connect to 200V the 100/200V changeover connector of FLT p.c.b. ❶ located on the side of the Box Side of the control box.
- Connect the crimp style terminal of AC input cord to the power plug as shown in the figure.

(Caution) Securely perform the insulation treatment to the red terminal which is not used with insulation tape or the like. (When the insulation is insufficient, there is a danger of electric shock or leakage current.)

5. Check that the change has been performed without fail before closing the rear cover.
6. Be careful that the cord is not pinched between the rear cover and the control box main unit. Close the rear cover while pressing the lower side of rear cover, and tighten four screws.

(4) Installing the sewing machine main unit



WARNING :

To prevent possible accidents caused by the fall of the sewing machine, perform the work by two persons or more when the machine is moved.

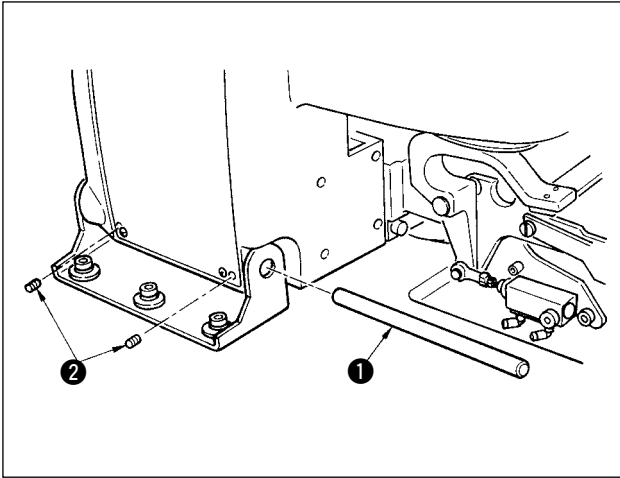

Adjust the sewing machine head to the hole of arm stay, and insert shaft ①. Fix shaft ① with screws ② in the state that the end faces of shaft ① are protruded on the both sides.



Be careful that wiring and air pipe coming out from the bottom face of the sewing machine are not crushed.

(5) Tilting the sewing machine head



WARNING :

When tilting/raising the sewing machine head, perform the work so as not to allow your fingers to be caught in the machine. In addition, to avoid possible accidents caused by abrupt start of the machine, turn OFF the power to the machine before starting the work.

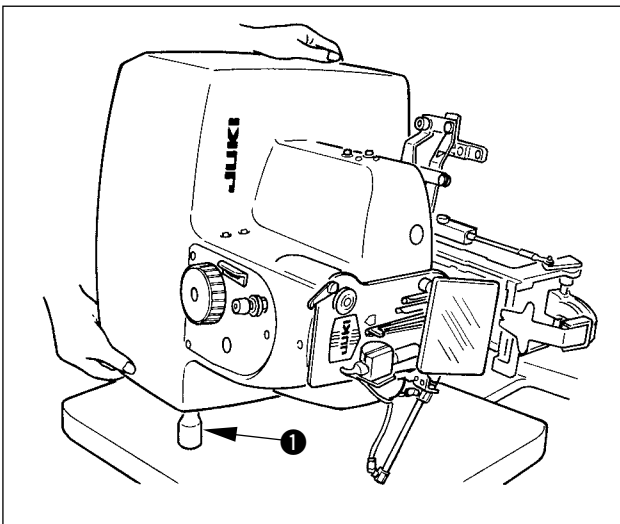

When tilting the sewing machine head, tilt quietly the sewing machine until head support bar ① comes in contact with it.



1. Make sure that sewing machine head support bar ① is placed on the table before tilting the sewing machine.
2. To protect fall-down, be sure to tilt the sewing machine in a level place.
3. Keep the table in the state that anything is not put on the top surface of table

(6) Removing the fixed plate for transport

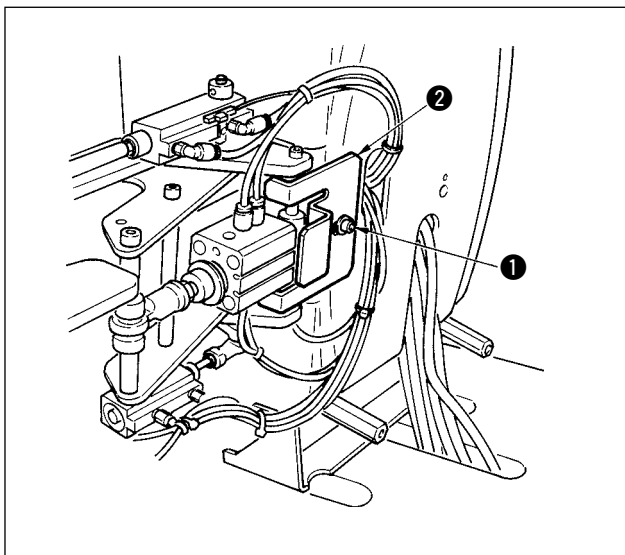

Remove fixed screw ① and remove fixed plate for transport ②.



Fixed screw ① and fixed plate for transport ② are necessary when transporting with the machine head single unit. So, keep them with care.

[Reference]

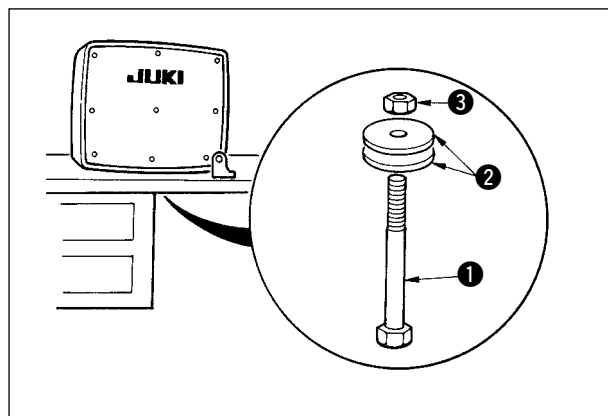

• In case of the complete transport

In case of the complete transport, fix the sewing machine to the table with screw ①, two flat washers ② and nut ③ supplied as accessories in order to safely transport the sewing machine.

(7) Installing the operation panel

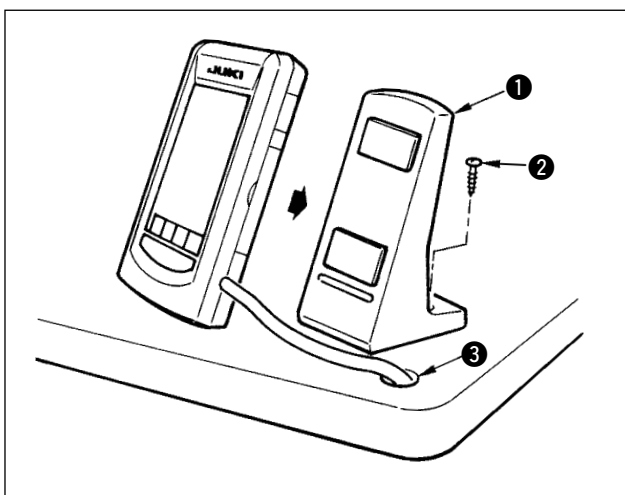

Fix operation panel attaching plate ① on the table with woodscrew ② and pass the cable through hole ③ in the table.

(8) Installing the air regulator

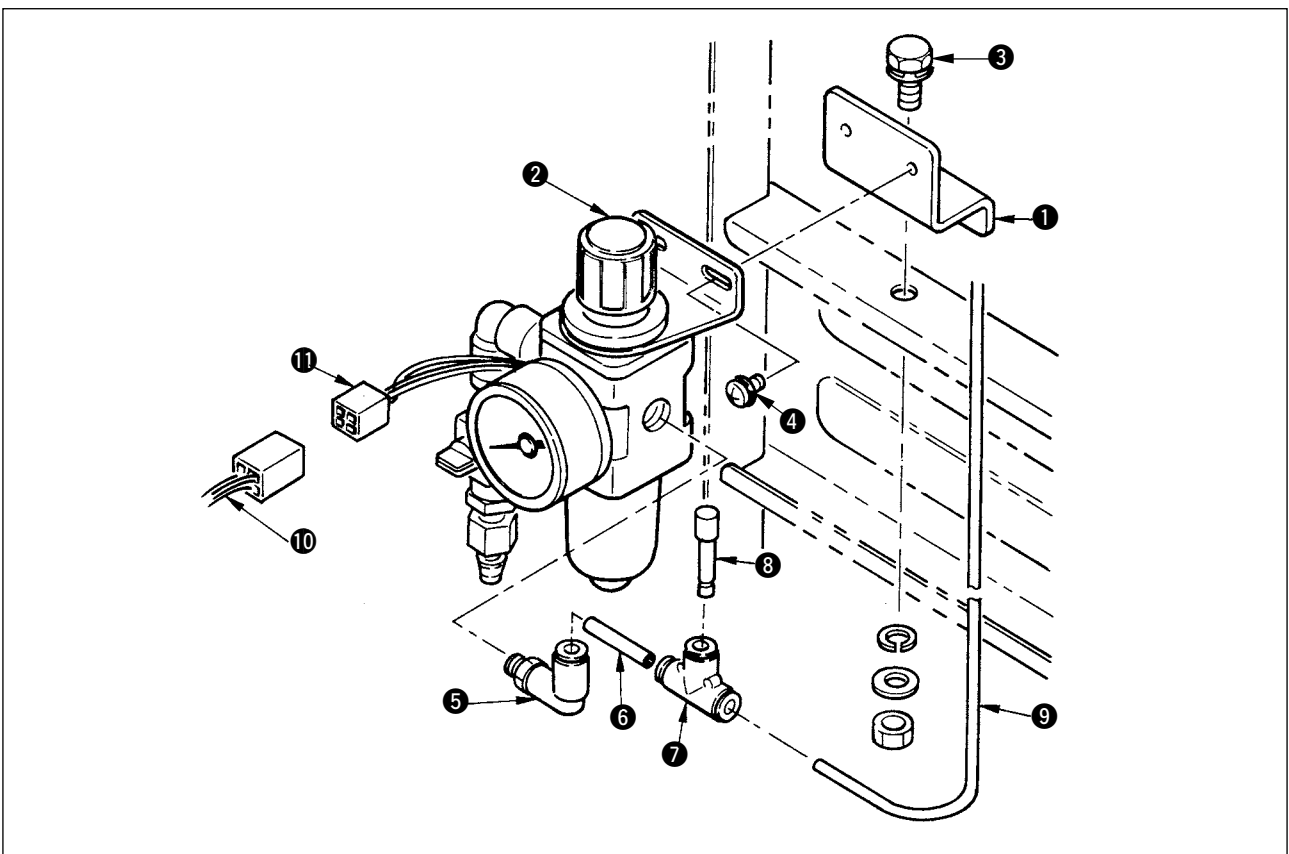

- 1) Install filter installing plate **1** on the right side of the stand side support with screw **3**.
- 2) Fix air regulator **2** on filter installing plate **1** with screw **4**.
- 3) Fix elbow union **5** on the right section of air regulator **2**.
- 4) Insert air hose **6** into elbow union **5**.
- 5) Insert reducing union T **7** into the top end of the air hose, and insert stop plug **8** into the hole of $\varnothing 6$.



Use the branch section ($\varnothing 6$) of reducing union T **7 when using the air gun.
Air gun set (G57602540A0) is available as optional.**

- 6) Insert air tube **9** coming from the main unit of machine head into reducing union T **7**.
- 7) Insert pressure sensor relay cord **10** into connector **11** of air regulator **2**.
- 8) Winding pressure sensor relay cord **10** around air tube **9**, insert it into the control box (CN41).
- 9) Supply air, and adjust the air pressure to 0.5 Mpa.

(9) Connecting the cords

Perform the connection of the cords as shown in the figure below.

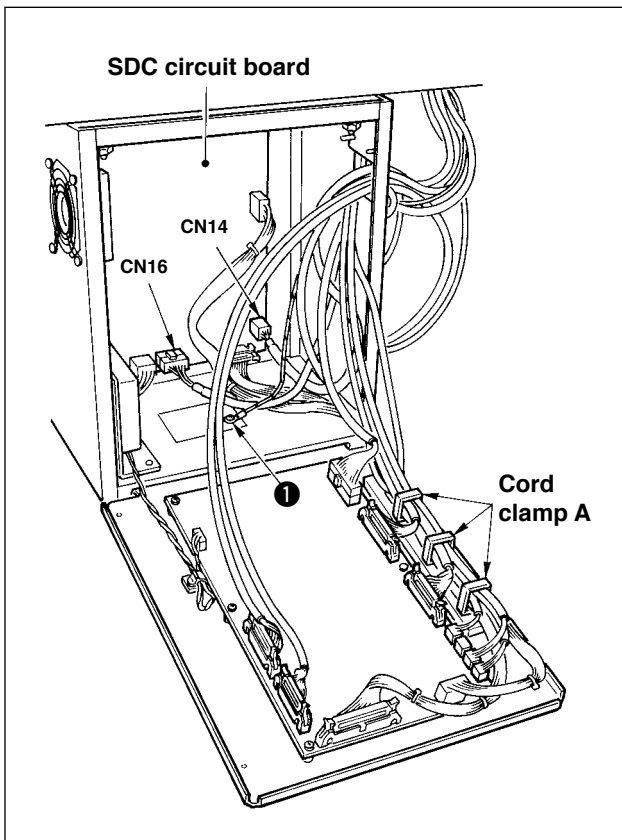
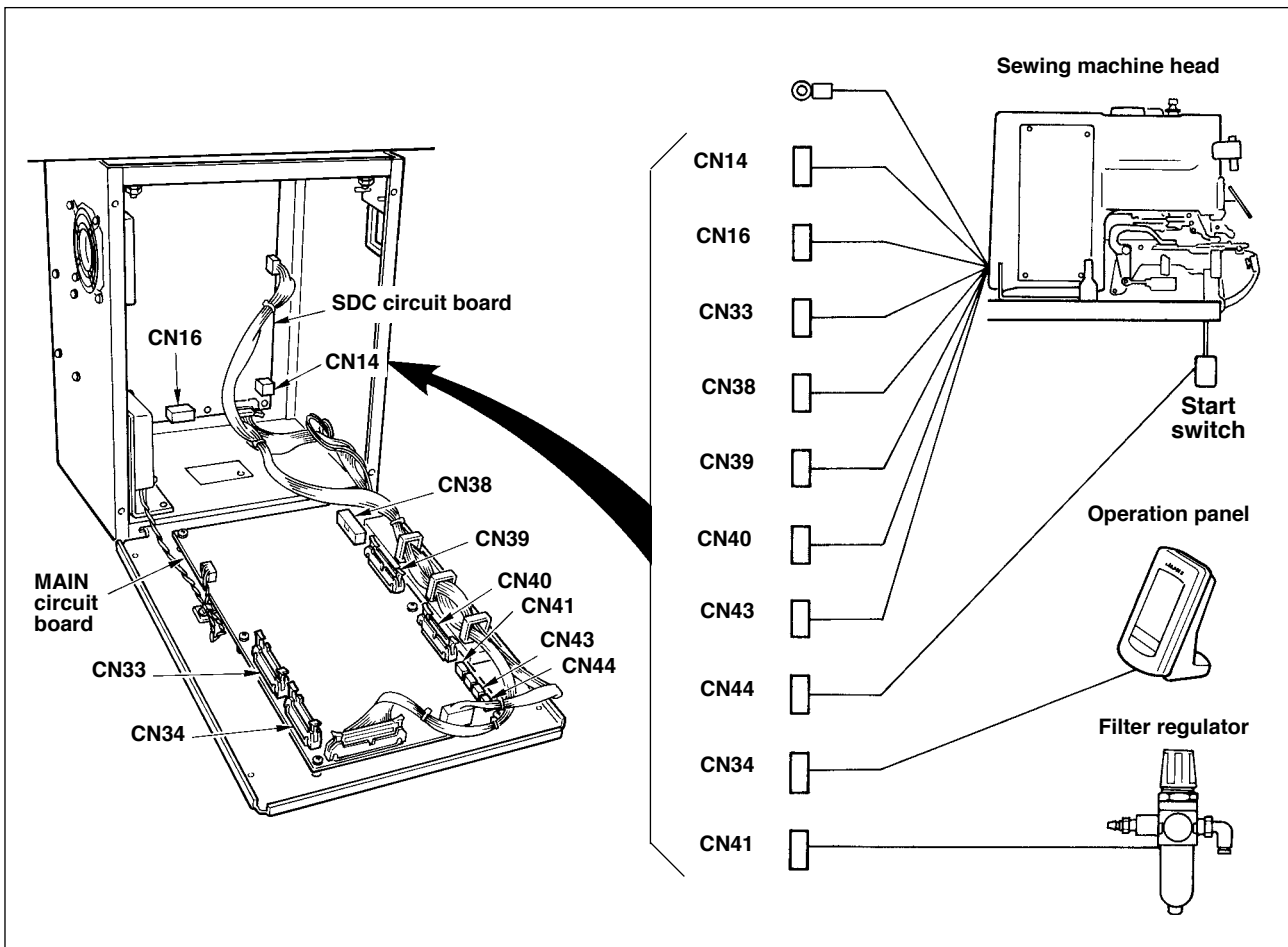

- 1) Pass 5 cords (CN39, 40, 41, 43 and 44) connecting to the right side among the cords connecting to MAIN circuit board through cord clamp A as shown in the figure, and connect them to the respective connectors. Connect CN38 to the connector without passing through cord clamp A.
- 2) Directly connect two cords connecting to the left side of MAIN circuit board to CN33 and CN34.
- 3) Connect the cords connecting to SDC circuit board directly to CN14 and CN16.
- 4) Fix the earth wire with the setscrew ❶.

(10) Managing the cord

- 1) Slowly tilting the sewing machine, check that the cords are not forcibly pulled.
- 2) Fix the cords with cord setting plate ① as shown in the figure.



When you tilt the sewing machine, make sure that the sewing machine head support bar ② is placed on the table.

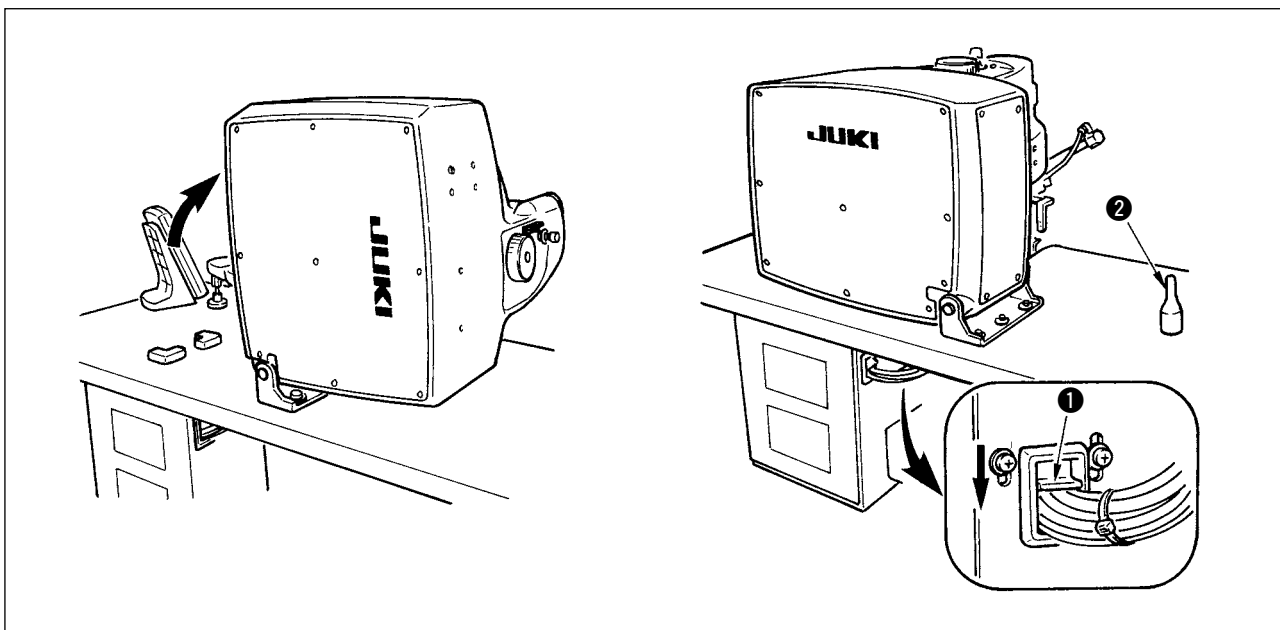

(11) Installing the eye protection cover and the finger guard



WARNING :

Be sure to attach this cover to protect the eyes from the disperse of needle breakage.

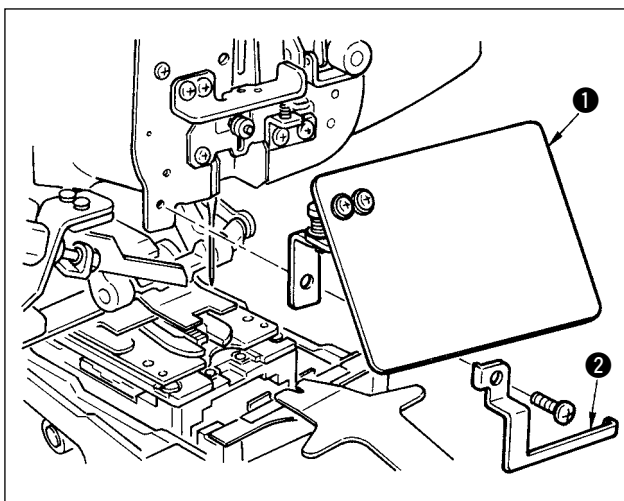

Be sure to install eye protection cover ① and finger guard ②, and use the sewing machine.

(12) Installing the thread stand

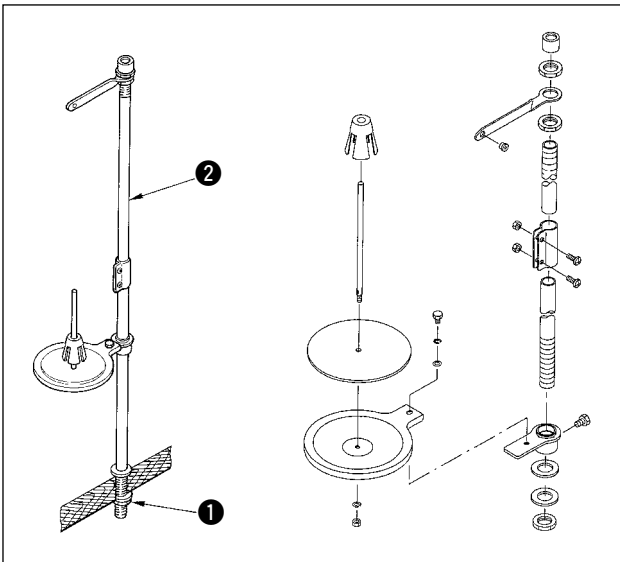

- 1) Assemble the thread stand, and set it in the hole in the top right corner of the machine table.
- 2) Tighten locknut ① to fix the thread stand.
- 3) When ceiling wiring is possible, pass the power cable through spool rest rod ②.

(13) Attaching the button tray

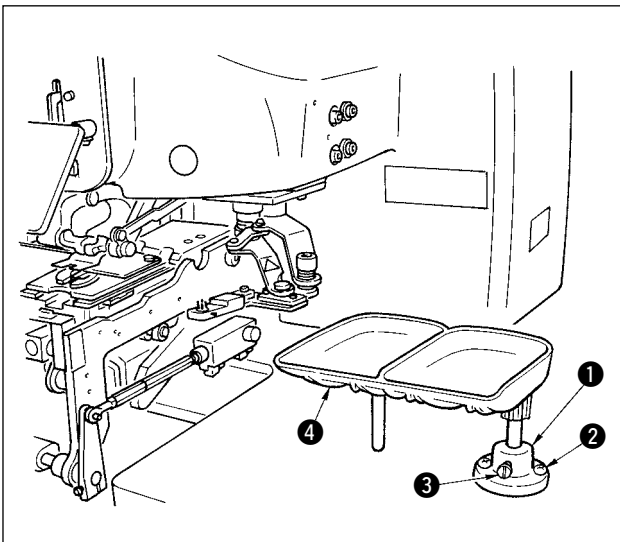

- 1) Fix base ① on the table with wood screw ②.
- 2) Insert button tray ④ in the hole of base ① and fix it with setscrew ③ after adjusting the position to that where the button can be taken with ease.



It is possible to change the loader set position as well. It is recommended to perform positioning them together. (Memory switch U04)

3. PREPARATION BEFORE OPERATION

(1) Inserting the needle



WARNING :

To protect against possible personal injury due to abrupt start of the machine, be sure to start the following work after turning the power off and ascertaining that the motor is at rest.

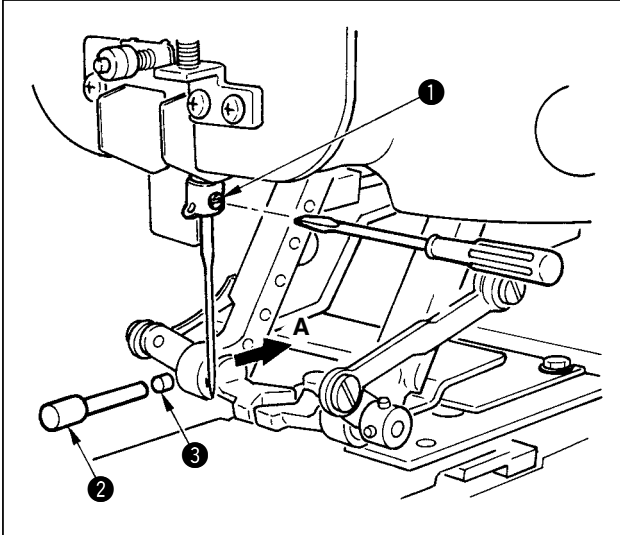

Hold needle with its recessed part facing toward side "A" as observed from the front of the sewing machine, insert the needle into the needle hole of needle bar until it will go no further, and tighten setscrew ① with a flat-blade screwdriver. Use a SM332EXTLG-NY(#11 to #18).



When attaching the needle, turn OFF the power to the motor.



Attach stop plug ② supplied as accessories (insert magnet ③ supplied as accessories into the top end) to the needle. It is recommended to confirm that the needle is vertical.

(2) Threading the needle-thread



WARNING :

To protect against possible personal injury due to abrupt start of the machine, be sure to start the following work after turning the power off and ascertaining that the motor is at rest.

Pass the needle thread in the order ① to ⑬ as shown in the figures.

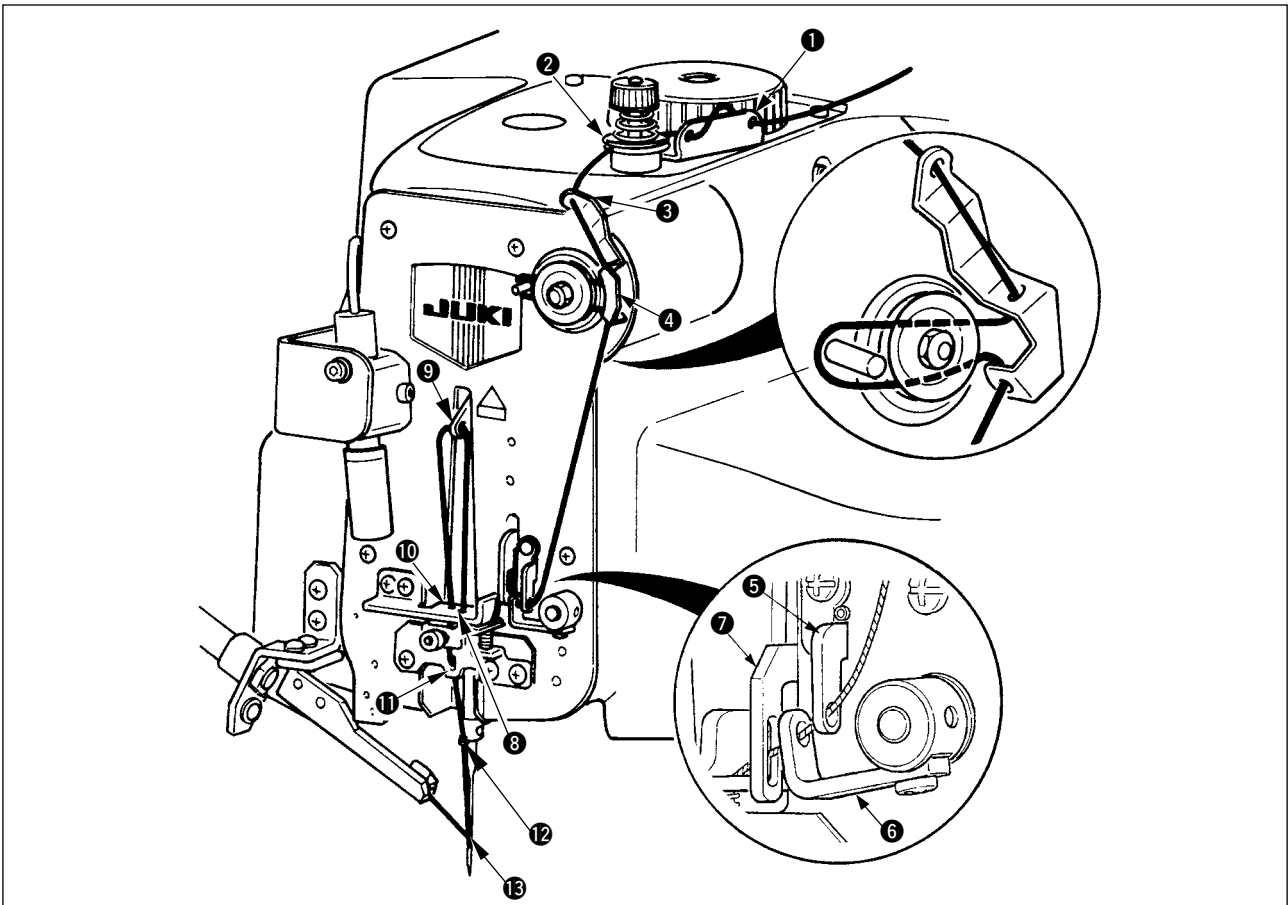

(3) Adjusting the stay (counter) button stopper



WARNING :

To protect against possible personal injury due to abrupt start of the machine, be sure to start the following work after turning the power off and ascertaining that the motor is at rest.

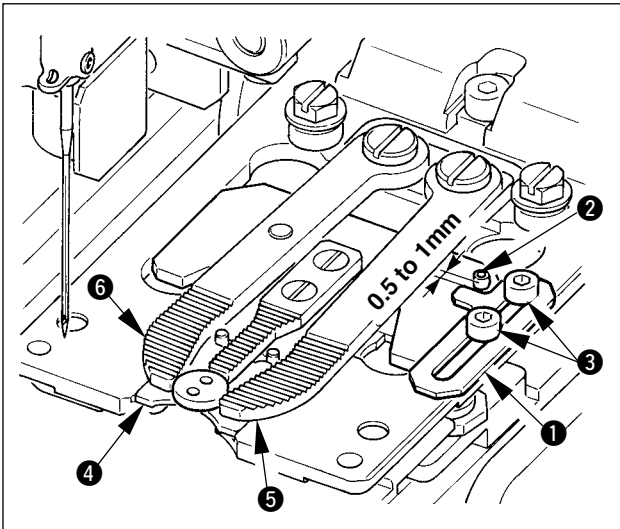

Loosen screws **3** and adjust so that the clearance between stopper **1** and pin **2** is 0.5 to 1 mm with the button used set. Then fix the stopper.

1. The size applicable to the stay button is $\varnothing 8$ to $\varnothing 25$, and the thickness is 2 mm or less.
2. Feed plate is made so as to make it easy to set the stay button of $\varnothing 8$ to $\varnothing 10$. Replace the feed plate with the feed plate for counter button when using the button which is not clamped with stay button clamps **5** and **6**, or using the button, the needle entry position of which is not fit to the window of gauge **4**.



[Reference]

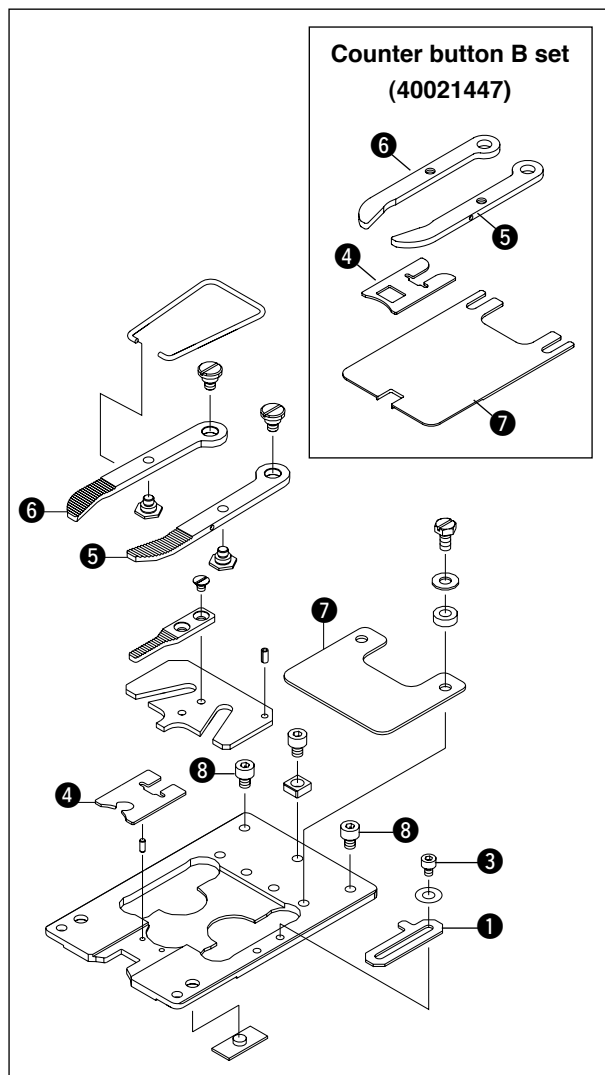

To change the feed plate to the feed plate for counter button, there are two kinds of methods ; changing as a set and replacing the components.

• In case of replacing as a set

- 1) Purchase the set (40020807) of feed plate for counter button. Loosen two screws **8** and replace the feed plate.

• In case of replacing the components

- 1) Purchase the counter button B set (40021447), loosen two screws **8**, and remove the feed plate from the machine head.
- 2) Replace the components **4**, **5**, **6**, and **7** with counter button B set (40021447).

1. Maximum size to be applied is $\varnothing 25$.
2. When installing the feed plate, insert it until it goes no further and fix it.



(4) Replacing the button chuck



WARNING :

To protect against possible personal injury due to abrupt start of the machine, be sure to start the following work after turning the power off and ascertaining that the motor is at rest.

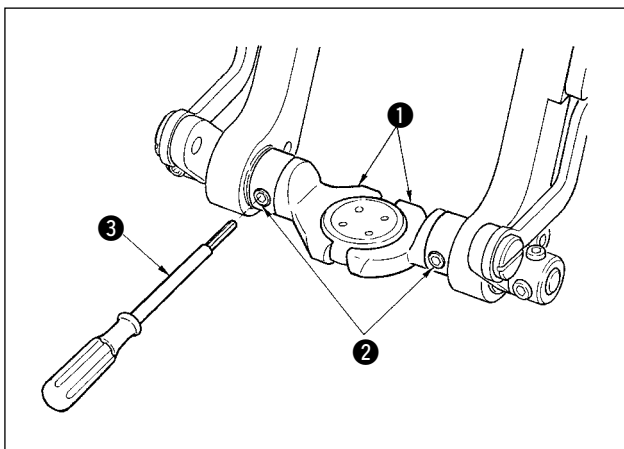

When replacing chuck ①, loosen screws ② and replace it with exclusive screwdriver ③ supplied as accessories.

<Button chuck correspondence table>

Part No.	Description	Outside diameter of button that can be used	Remarks
40020932	Button chuck (small)	ø 8 to 16 mm	Accessory
40020931	Button chuck (medium) (standard)	ø 14 to 25 mm	Installed on machine head
40020930	Button chuck (large)	ø 25 to 38 mm	Accessory

(5) Set of the button neck wrapping

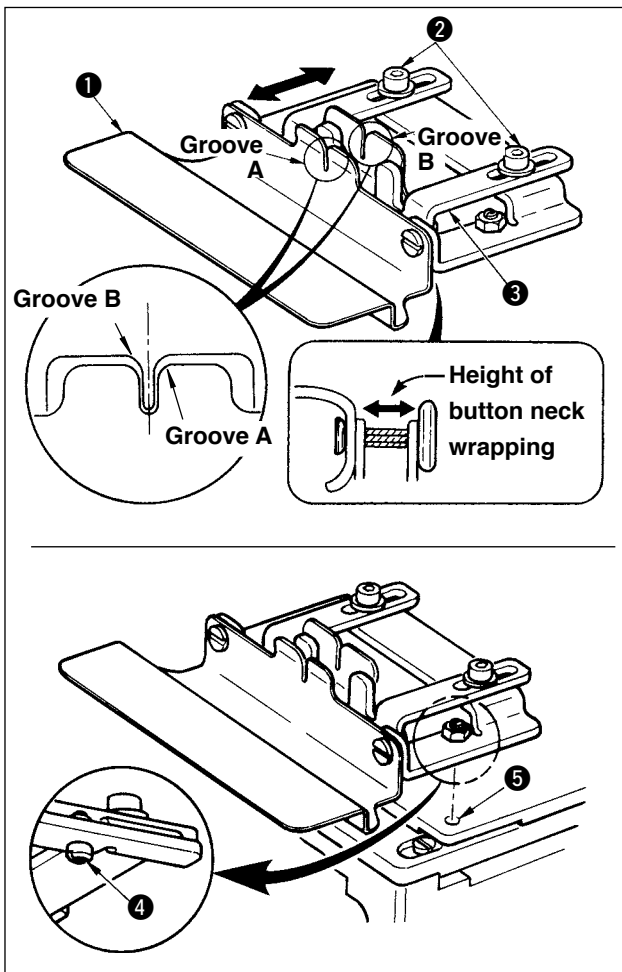

When performing the button neck wrapping process of stay (counter) button, use the button neck wrapping attachment (accessories) ①. Loosen screws ② and move holder plate ③ to and fro to perform the adjustment of the height of button neck wrapping attachment.



Confirm that button neck wrapping positioning grooves A and B are straight front and rear.

[Setting procedure of the button neck wrapping attachment]

Insert convex ④ of the attachment to concave ⑤ of the feed plate at the time of the button neck wrapping process pattern.

(6) Set of the sewing flat button with blindstitch

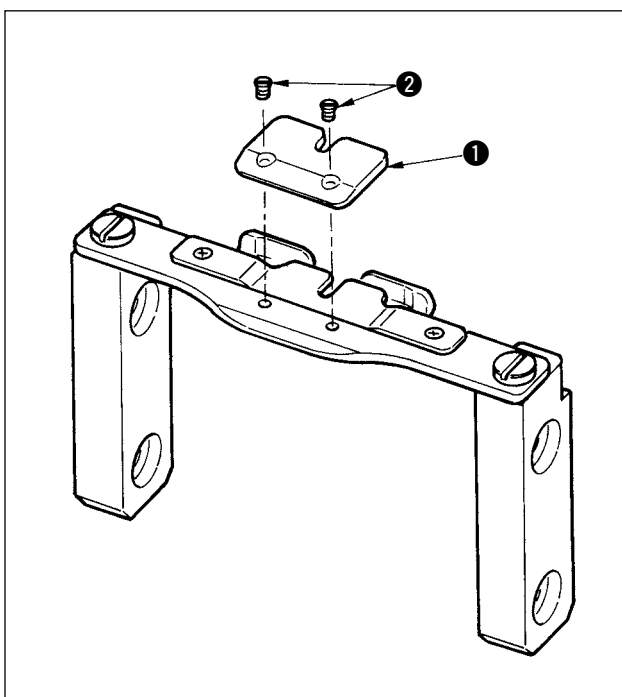

When performing the sewing flat button with blindstitch, insert underplate spacer A ① supplied as accessories (Part No. : 40020764) to the pin position. In addition, fix it with screws ② when using it always.

Select and use a proper underplate spacer from among the underplate spacers below according to the thickness of cloth.

Discription	Thickness	Part No.	Remarks
UNDER_PLATE_SPACER A	t=1.6	40020764	Accessory
UNDER_PLATE_SPACER B	t=2.0	40020769	Optional
UNDER_PLATE_SPACER C	t=2.6	40020770	Optional

4. ADJUSTMENT OF THE SEWING MACHINE

(1) Adjusting the needle and the looper

1) Adjusting the needle bar height

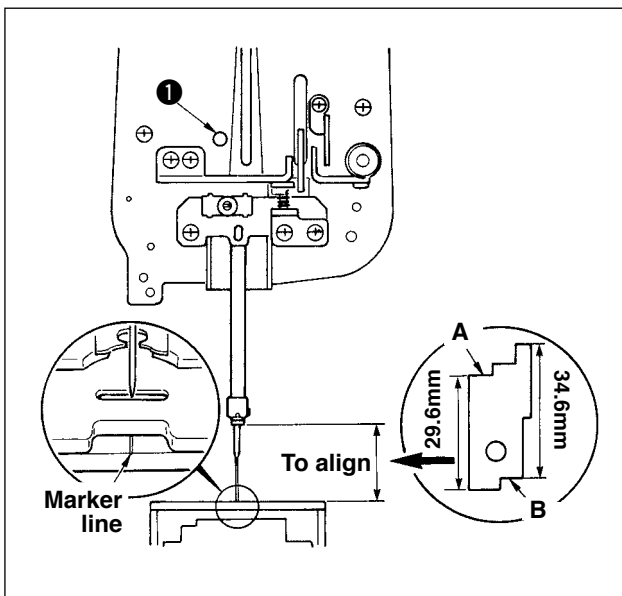

Use the timing gauge supplied as accessories.

Loosen screw ❶ and adjust so that plane **A** in case of SM332EXTLG-NY (standard needle) or plane **B** in case of SM332SUPLG-NY aligns with the height of the throat plate when the needle bar comes down to the lowest position.



Perform the adjustment at the needle rocking origin (marker line).

[Needle list]

JUKI Part No.	Needle Part No.
MSM3AAN1100	NEEDLE SM332EXTLG-NY #11
MSM3AAN1200	NEEDLE SM332EXTLG-NY #12
MSM3AAN1400	NEEDLE SM332EXTLG-NY #14
MSM3AAN1600	NEEDLE SM332EXTLG-NY #16
MSM3AAN1800	NEEDLE SM332EXTLG-NY #18
MSM3ABN1100	NEEDLE SM332SUPLG-NY #11
MSM3ABN1200	NEEDLE SM332SUPLG-NY #12
MSM3ABN1400	NEEDLE SM332SUPLG-NY #14
MSM3ABN1600	NEEDLE SM332SUPLG-NY #16
MSM3ABN1800	NEEDLE SM332SUPLG-NY #18

2) Adjusting the clearance between the needle and the looper

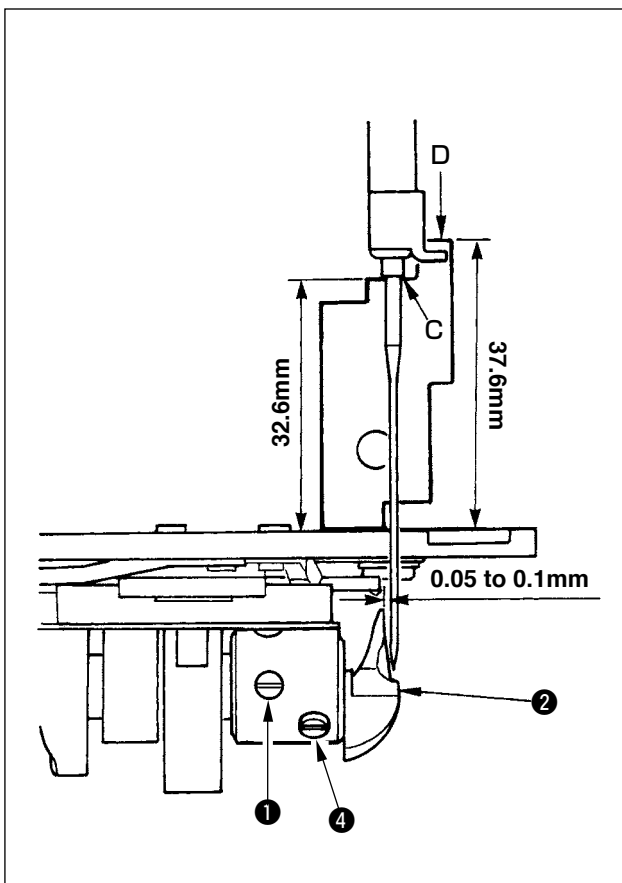

Use the timing gauge supplied as accessories.

Loosen two screws ❶, move looper ❷ and adjust by loosening screw ❹ so that the clearance between the needle and the blade tip of looper is 0.05 to 0.1 mm when plane **C** in case of SM332EXTLG-NY (standard needle) or plane **D** in case of SM332SUPLG-NY aligns with the height of the needle bar.

In addition, adjust so that the left position of needle ❸ aligns with the top end of looper ❷ as observed from the front.

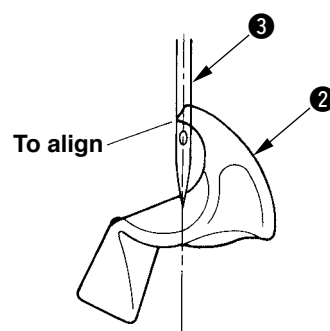

(2) Adjusting the position of the york slide

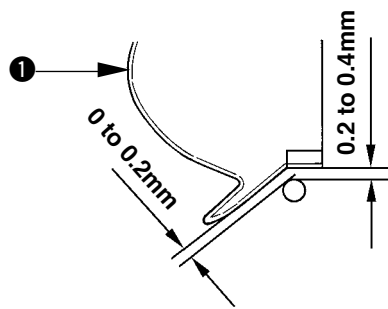
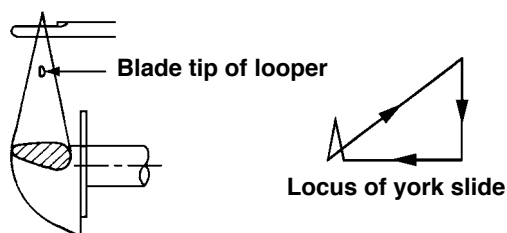
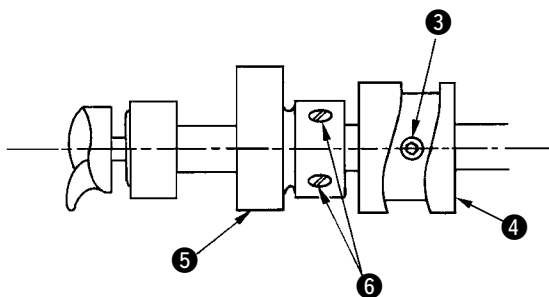
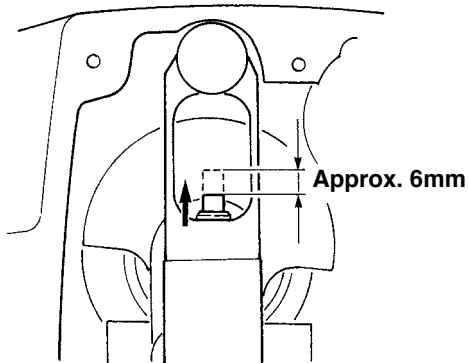
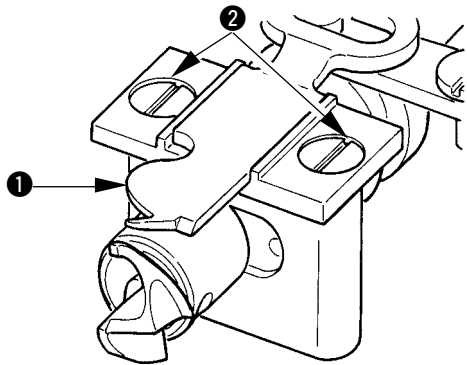

Fig. 1



- 1) The position of york slide ① has been factory-assembled so that the clearance between york slide ① and the needle is longitudinally 0.2 to 0.4 and laterally 0 to 0.2 mm when the needle bar comes to the lowest position. (Refer to Fig. 1.)
- 2) Adjust the lateral position of york slide ① by loosening setscrews ② and moving york slide ① laterally.
- 3) Adjust the longitudinal position of york slide ① by loosening setscrew ③ and moving york slide cam ④ longitudinally. The motion timing of york slide cam ④ at this time is adjusted by making the engraved marker line on york slide cam ④ directly below and tightening the cam with setscrew ③ when the needle bar is at the lowest position.
- 4) Timing of the york slide motion is performed in the order that the york slide moves from the left to the right and starts retracting immediately after the blade tip of looper has passed the triangle of the thread. (Position where the needle bar goes up approximately 6 mm from the lowest position)
- 5) Loosen setscrews ⑦ in york slide triangle cam ⑥ and turn the cam in the direction of rotation to perform this adjustment.



Marks made by the electron pen have been put on york slide cam ④ and york slide triangle cam ⑤ at the time of delivery from factory. Make them as the standard of timing adjustment.

- 6) For the locus of york slide motion, loosen setscrew ④ in york slide cam ⑤ and turn the cam in the direction of rotation to adjust so that the locus becomes a triangle while keeping the clearance (0 to 0.2 mm) between the needle and the york slide when the needle goes up.

(3) Adjusting the needle and the needle guide

1) Adjusting the position of the needle and the throat plate

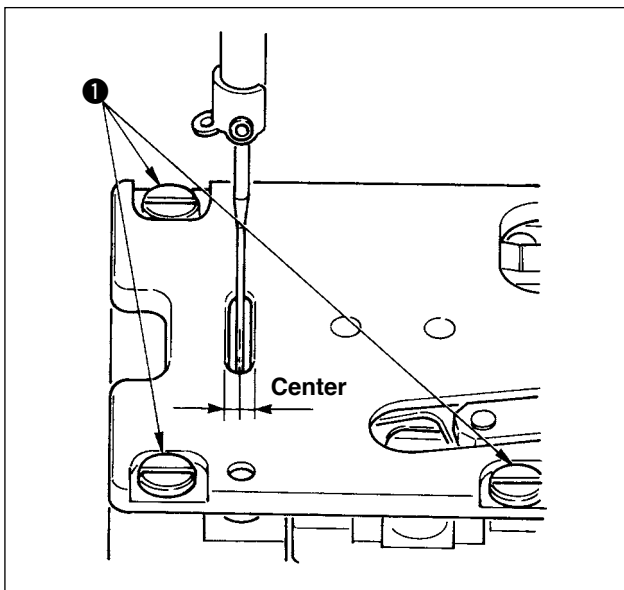

Loosen screws ❶ and adjust the throat plate so that the needle enters the center of the needle hole.

2) Adjusting the clearance between the needle and the needle guide

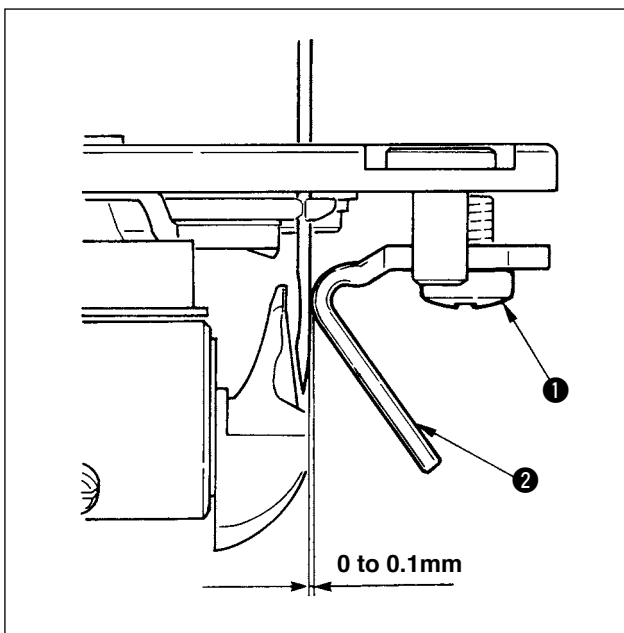

Loosen screw ❶ and adjust so that the clearance between needle guide ❷ and the needle is 0 to 0.1 mm at the lowest position of the needle bar.

(4) Adjusting the thread trimmer mechanism

1) Adjusting the position of the moving knife

First adjustment

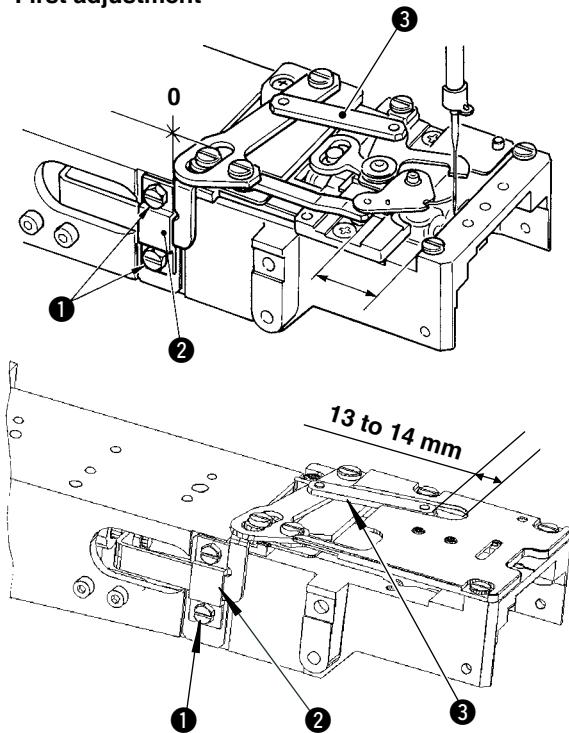

[Waiting position]

1. Loosen screws ① and close the clearance with stopper ② so that the dimension between the edge of fixed knife link ③ and the groove end of throat plate is 13 to 14 mm. Then fix screws ①.

Second adjustment

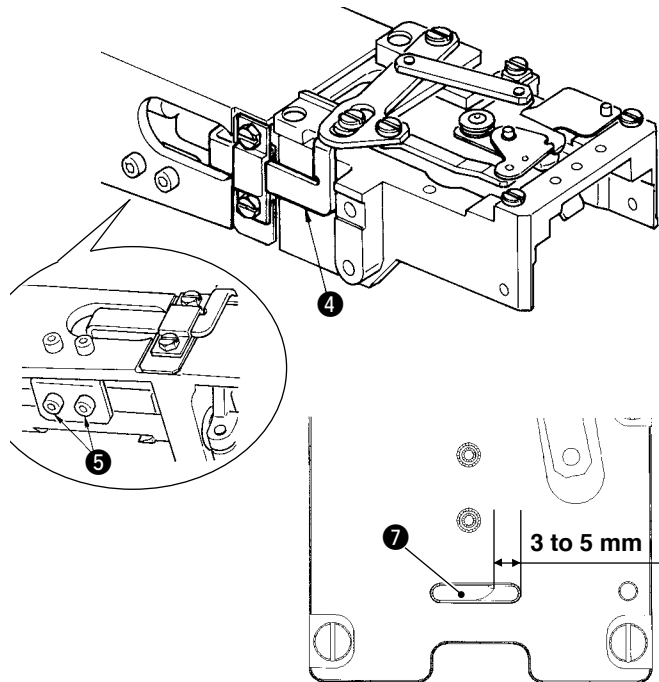

[Thread trimming position]

1. Adjust the clearance between the blade point of moving knife ⑦ and the right end of the slot of throat plate is 3 to 5 mm in the state that air only is ON (solenoid valve No. 14), loosen screws ⑤, actuate the cylinder, and fix screws ⑤ in the state that the clearance is closed.
2. After the adjustment, check that moving knife link ④ smoothly moves.

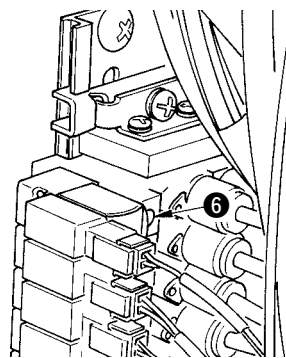

When the work is completed, do not forget to perform the release of lock ⑥ of the solenoid valve.

2) Adjusting the moving knife thread separation nail

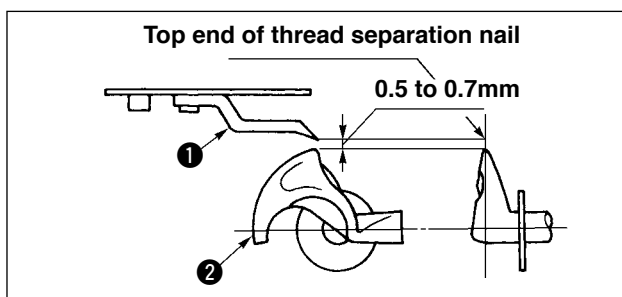

Bend thread separation nail ① using a screwdriver or the like and adjust so that a clearance of 0.5 to 0.7 mm should be provided between thread separation nail ① and looper ②.

(5) Adjusting the wiper mechanism

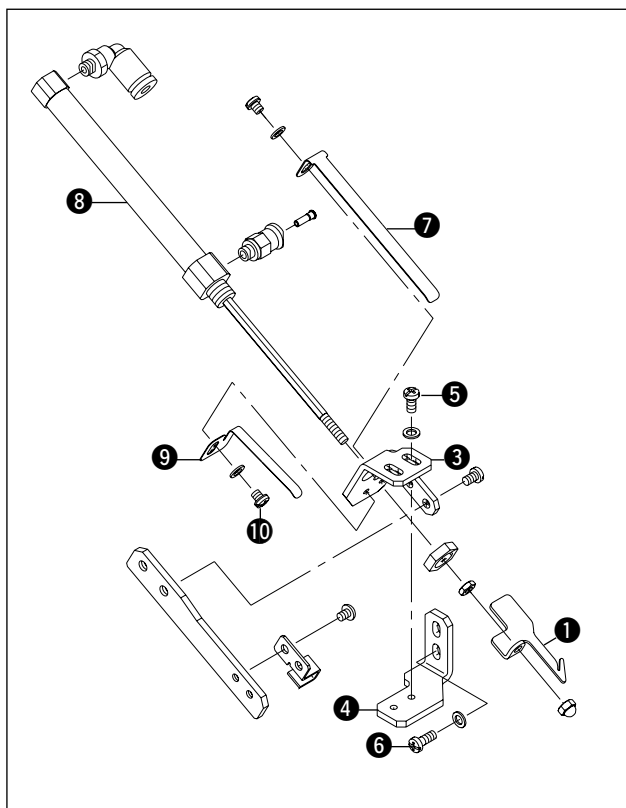

- 1) Turn OFF the air, and draw wiper ① until it goes no further.
- 2) Adjust wiper cylinder installing bases A ③ and B ④ with the respective setscrews ⑤ and ⑥ so that the vertical clearance between needle tip ② and the top surface of wiper ① is 3 to 5 mm and the lateral dimension between needle tip ② and the thread holding section of wiper ① is 6 to 8 mm at the sewing machine stop position (needle bar upper dead point).
- 3) Fix spring A ⑦ so that wiper ① and spring A ⑦ equally come in contact with each other on the plane within the range of the stroke of cylinder ⑧.
- 4) Adjust the holding force of thread with spring B ⑨.
- 5) To adjust the holding force, loosen screw ⑩ and adjust so that thread slips off with the force of approximately 20 to 25g when polyester spun thread #50 is held.

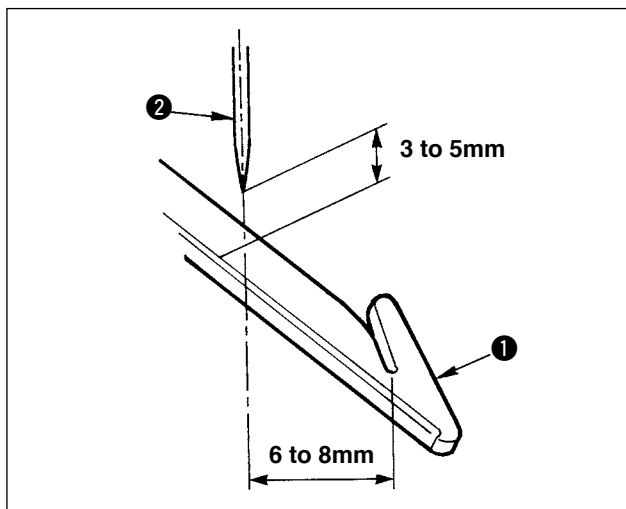

(6) Adjusting the chuck open mechanism

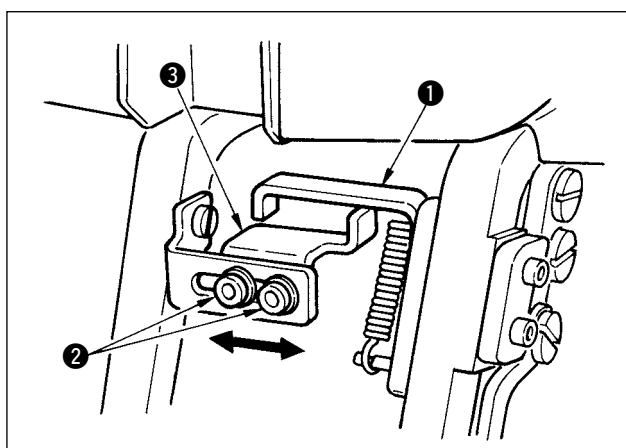

When the mode is changed over to the manual button control mode, raise hook A ① to decrease the open amount. Adjust the open amount by loosening screws ② and sliding hook B ③ to the right and left.



When the mode is changed over to the button loader motion mode, do not forget to release hook A ①.

5. MAINTENANCE

(1) Replacing the attachments

1) Replacing the button set pin (optional)

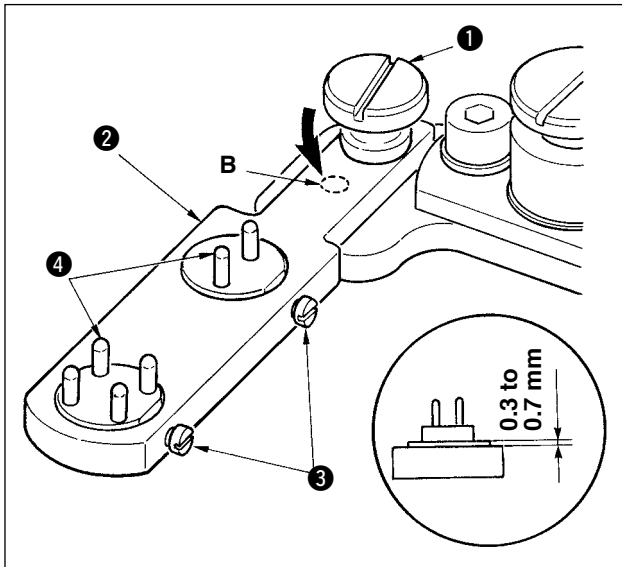

When replacing button set pin ②, loosen knob ① and replace it. However, when replacing the set pin with those below, remove knob ① and install it in the screw hole on side B.

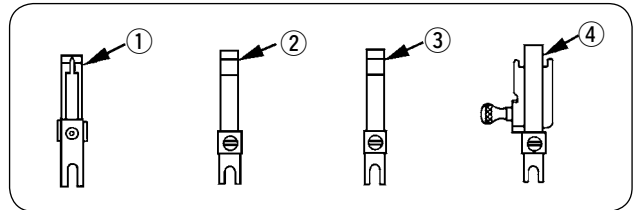

No.	Part No.	Description
①	17974056	Set pin for marble button
②	17974254	Set pin for shank button (ϕ 1.5 to ϕ 2.0)
③	17974452	Set pin for shank button (ϕ 2.0 or more)
④	40023428	Set pin for metallic button

2) Replacing the carrier pin

When replacing carrier pin ④, loosen screws ③ and replace it.

At this time, adjust the height of the carrier pin to 0.3 to 0.7 mm from the top surface of the set pin.

<Carrier pin list>

Button carrier (for 4-holed button)									Button carrier (for 2-holed button)					
1			2			3			4			5		
Stamp	Part No.	Dimensions	Stamp	Part No.	Dimensions	Stamp	Part No.	Dimensions	Stamp	Part No.	Dimensions	Stamp	Part No.	Dimensions
A	17856600	a 2.0 b 1.0	D	17856907	a 2.8 b 1.2	K	17857608	a 4.0 b 1.4	M	17858002	a 2.0 b 1.0	U	17858705	a 4.0 b 1.4
B	17856709	a 2.4 b 1.2	E	17857004	a 2.8 b 1.4	K1	17857707	a 4.0 b 1.8	N	17858101	a 2.4 b 1.2	V	17858804	a 4.2 b 1.4
C	17856808	a 2.6 b 1.2	F	17857103	a 3.0 b 1.2	L	17857806	a 5.0 b 1.8	P	17858200	a 2.6 b 1.2	W	17858903	a 4.4 b 1.4
			F1	17857202	a 3.0 b 1.4				Q	17858309	a 2.8 b 1.2	X	17859000	a 4.6 b 1.4
			G	17857301	a 3.2 b 1.4				R	17858408	a 3.0 b 1.2	Y	17859109	a 4.8 b 1.4
			H	Standard spec 17857400	a 3.4 b 1.4				S	17858507	a 3.2 b 1.4	Z	17859208	a 5.0 b 1.4
			J	17857509	a 3.6 b 1.4				T	Standard spec 17858606	a 3.4 b 1.4			

3) Replacing the tongue stopper

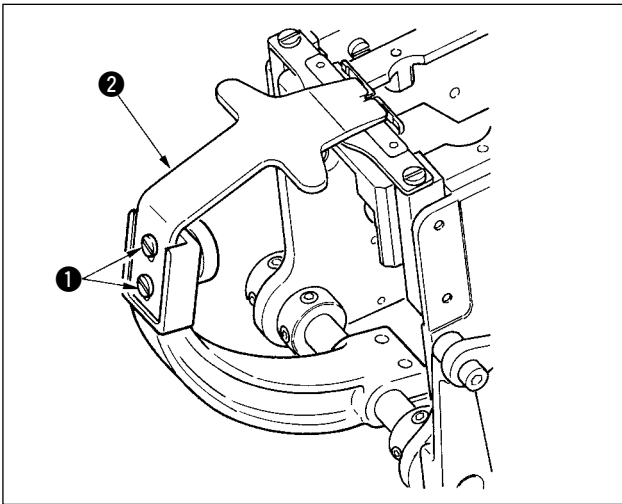

When using the standard 4-holed tongue (Part No. 25006602) of the former AMB-189N, replace the tongue stopper guide together.

- 1) Replacing the tongue
Remove screws **1** and replace tongue **2**.

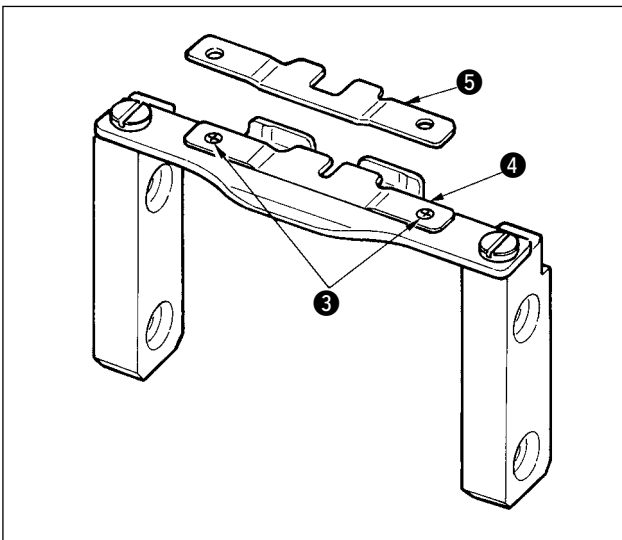

- 2) Replacing the tongue stopper guide
Remove screws **3** and replace tongue stopper guide **4** with tongue stopper guide B (Part No. : 40020763) **5** supplied as accessories.
- 3) Finally, perform the change of memory switch level K12.

(2) Replacing the fuse



WARNING :

1. To avoid electrical shock hazards, turn OFF the power and open the control box cover after about five minutes have passed.
2. Open the control box cover after turning OFF the power without fail. Then, replace with a new fuse with the specified capacity.

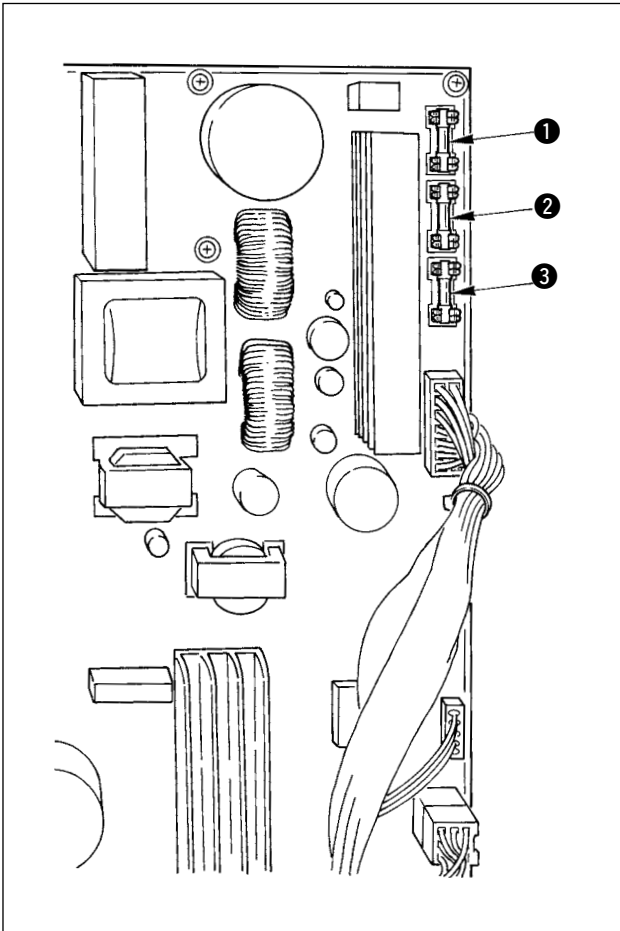

The machine uses the following three fuses :

- ① For pulse motor power supply protection
5A (time-lag fuse)
- ② For solenoid and pulse motor power supply protection
3.15A (time-lag fuse)
- ③ For control power supply protection
2A (fast-blow type fuse)

(3) Greasing parts



WARNING :

Turn OFF the power before starting the work so as to prevent accidents caused by abrupt start of the sewing machine.

Periodically perform grease-up every 6 months as a standard, or perform grease-up when



(grease-up time) is displayed on the operation panel.

There are three kinds of the exclusive greases supplied as accessories.

- Grease in grease tube (green, Part No. 13525506)

→ Apply grease to rack, gear and cam section.

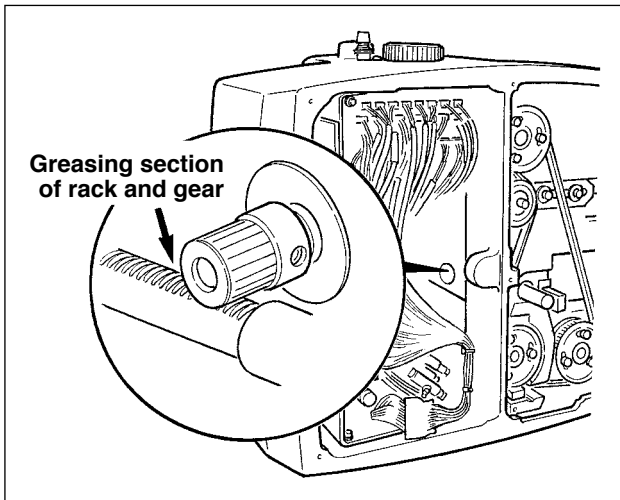

- 1) Remove the rear cover, and apply grease to rack and gear section of Y top feed.

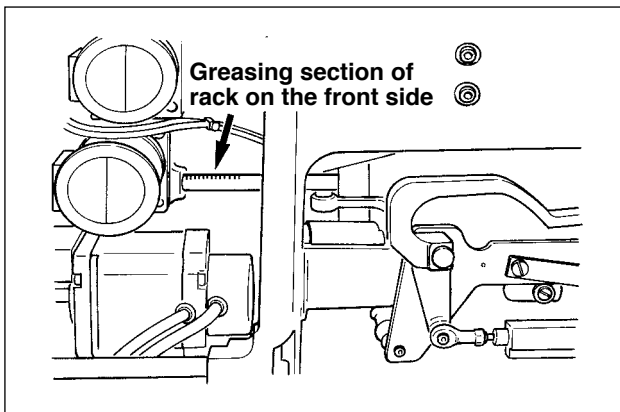

- 2) Remove the rear cover and the side cover, and apply grease to rack and gear section of Y bottom feed.

- Move the bottom unit to the extreme front, and apply grease to the front section of the rack section.

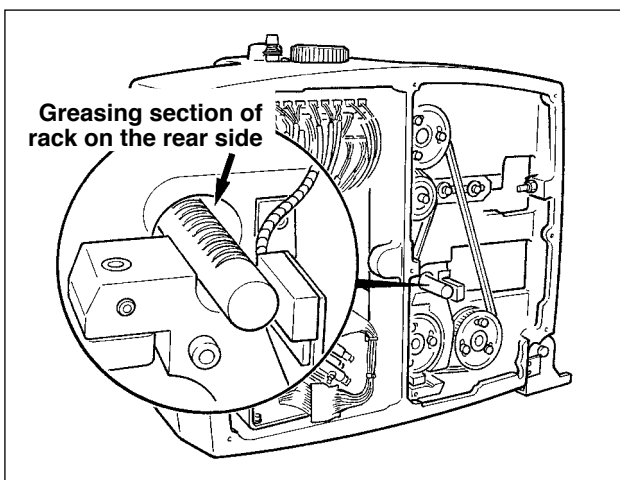

- Move the bottom unit to the extreme rear, and apply grease to the rear section of the rack section.

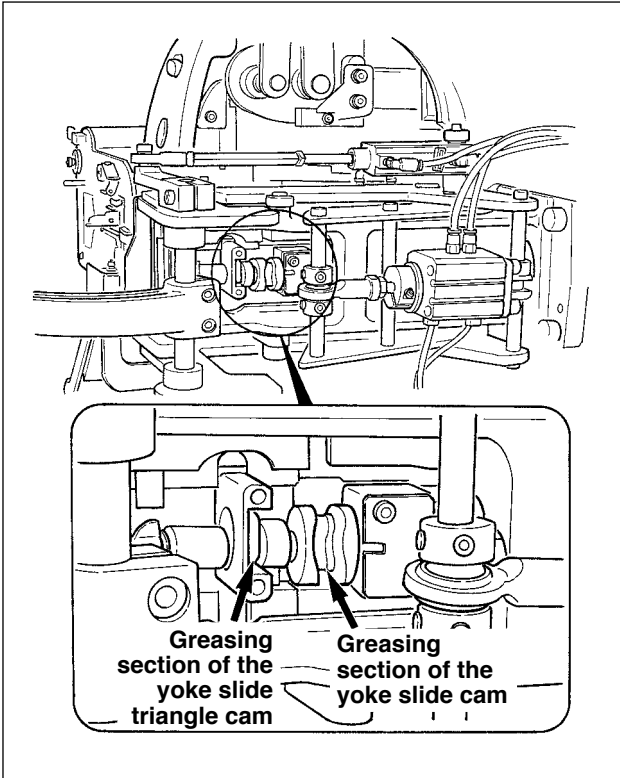

3) Apply grease to the yoke slide cam and the yoke slide triangle cam sections.

- Tilt the machine head
- Remove the looper cover.
- Turning the hand pulley, apply grease to the lateral cam section.



For the greasing section of the yoke slide cam, use grease in JUKI grease A tube (white, Part No. 40006323).

○ Grease in JUKI grease B tube (white, Part No. 40013640)

→ Remove the top cover and apply grease to the worm section.

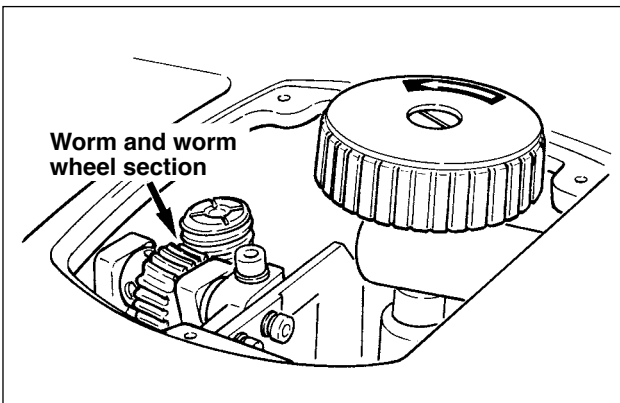

- Use the groove of top surface of worm, turning with the flatblade screwdriver, apply grease to moving parts of the worm and worm wheel.

○ Grease in JUKI grease A tube (white, Part No. 40006323)

→ Apply grease to other parts such as rotation fulcrum section, link moving section, etc.

- (Caution)**
1. When applying grease, apply new grease after carefully wiping old grease with a piece of cloth or the like.
 2. When the air gun or the like is blown to the greasing parts and the grease is scattered, perform grease-up again.

6. AIR CIRCUIT DIAGRAM

No.	PART NO.	DESCRIPTION	QTY
1	40019187	FILTER REGULATOR	1
2	40019195	CHUCK VER SWITCH ASSY	1
3	40019196	CHUCK HOR SWITCH ASSY	1
4	40019197	FEED UP SWITC ASSY	1
5	40019198	FEED DOWN SWITCH ASSY	1
6	40019199	TONGUE OPEN SWITCH ASSY	1
7	40021002	SOLENOID VALVE ASSY	1
8	BT0180101EB	TUBE HOSE	1m
9	BT0400251EB	TUBE HOSE	12m
10	BT0800501EB	TUBE HOSE	2m
11	G23013090A0	AIR CYLINDER	1
12	PA0600504A0	AIR CYLINDER	1
13	PA0801501A0	AIR CYLINDER	2
14	PA1002010A0	AIR CYLINDER	2
15	PA1002011A0	AIR CYLINDER	1
16	PA1007502A0	AIR CYLINDER	1
17	PA1502502A0	AIR CYLINDER	1
18	PA1602006B0	AIR CYLINDER	1
19	PA1602008A0	AIR CYLINDER	1
20	PA2001506A0	AIR CYLINDER	1
21	PC012406000	SPEED CONTROLLER	4
22	PC022403E00	INSERT RING	3
23	PJ046052503	HOSE ELBOW	3
24	PJ210304010	HALF UNION	2
25	PJ303040005	UNION	5
26	PJ304020301	ELBOW	6
27	PL304040504	ELBOW UNION	7
28	PJ304085201	ELBOW UNION	1
29	PJ305020001	T-JOINT	2
30	PJ305080001	PIPE TEE	1
31	PJ308040002	QUICK COUPLING	1
32	PJ301040502	HOSE ELBOW	4
33	PX500140000	PLUG	6
34	PX950001000	PLUG	1
35	180350006	WIRE MARK1	4
36	18035105	WIRE MARK2	4
37	18035204	WIRE MARK3	4
38	18035303	WIRE MARK4	4
39	18035402	WIRE MARK5	4
40	18035501	WIRE MARK6	4
41	18035600	WIRE MARK7	4
42	18035709	WIRE MARK8	4
43	18035808	WIRE MARK9	4
44	18035907	WIRE MARK10	4
45	18036004	WIRE MARK11	4
46	18036103	WIRE MARK12	4
47	18036202	WIRE MARK13	4
48	18036301	WIRE MARK14	4
49	18036400	WIRE MARK15	4
50	18036509	WIRE MARK16	4
51	18036608	WIRE MARK17	4
52	18036707	WIRE MARK18	4
53	18036806	WIRE MARK19	4
54	18036905	WIRE MARK20	4

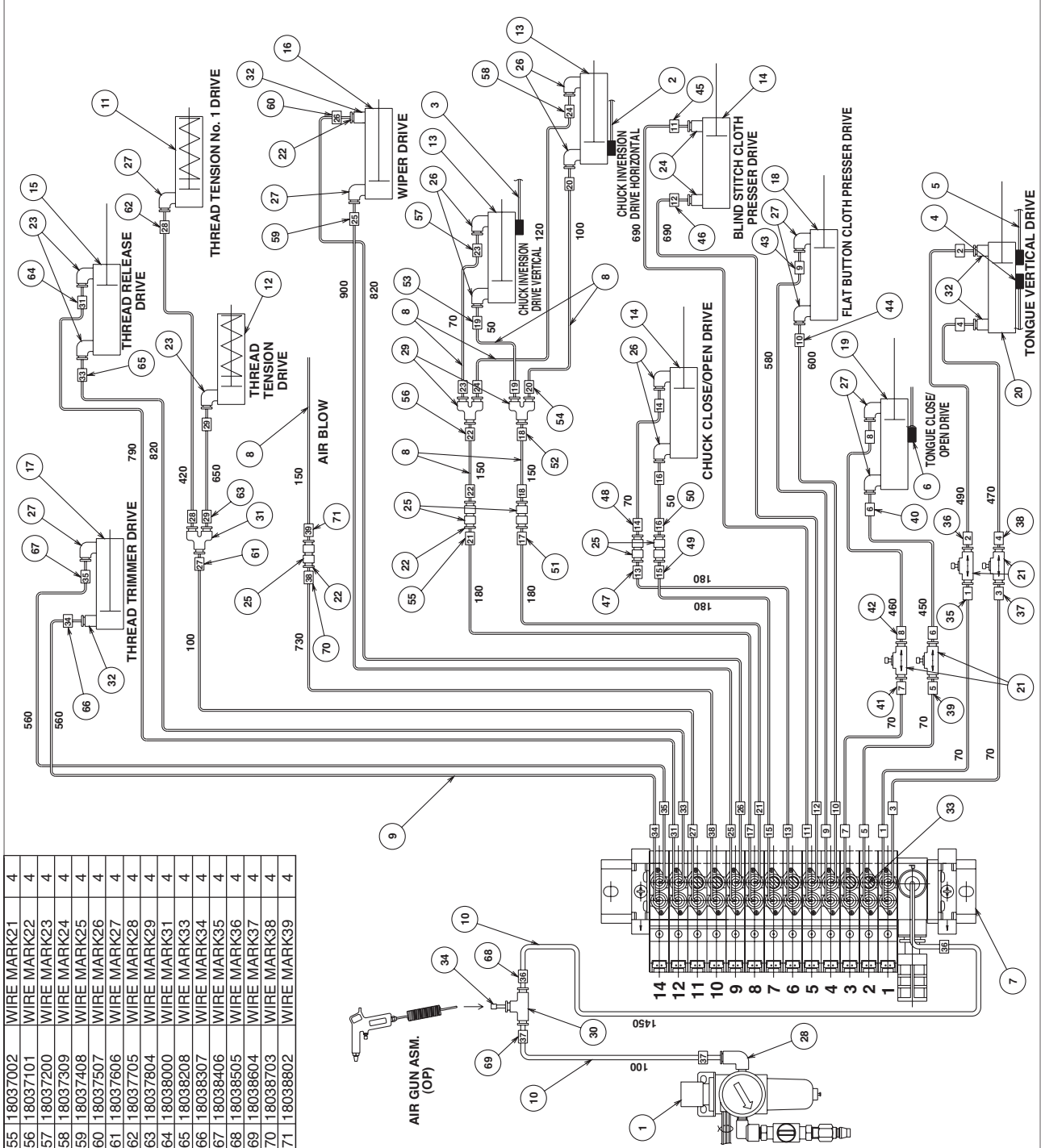

7. DRAWING OF THE TABLE

(1) Table

Part No. : 40020990

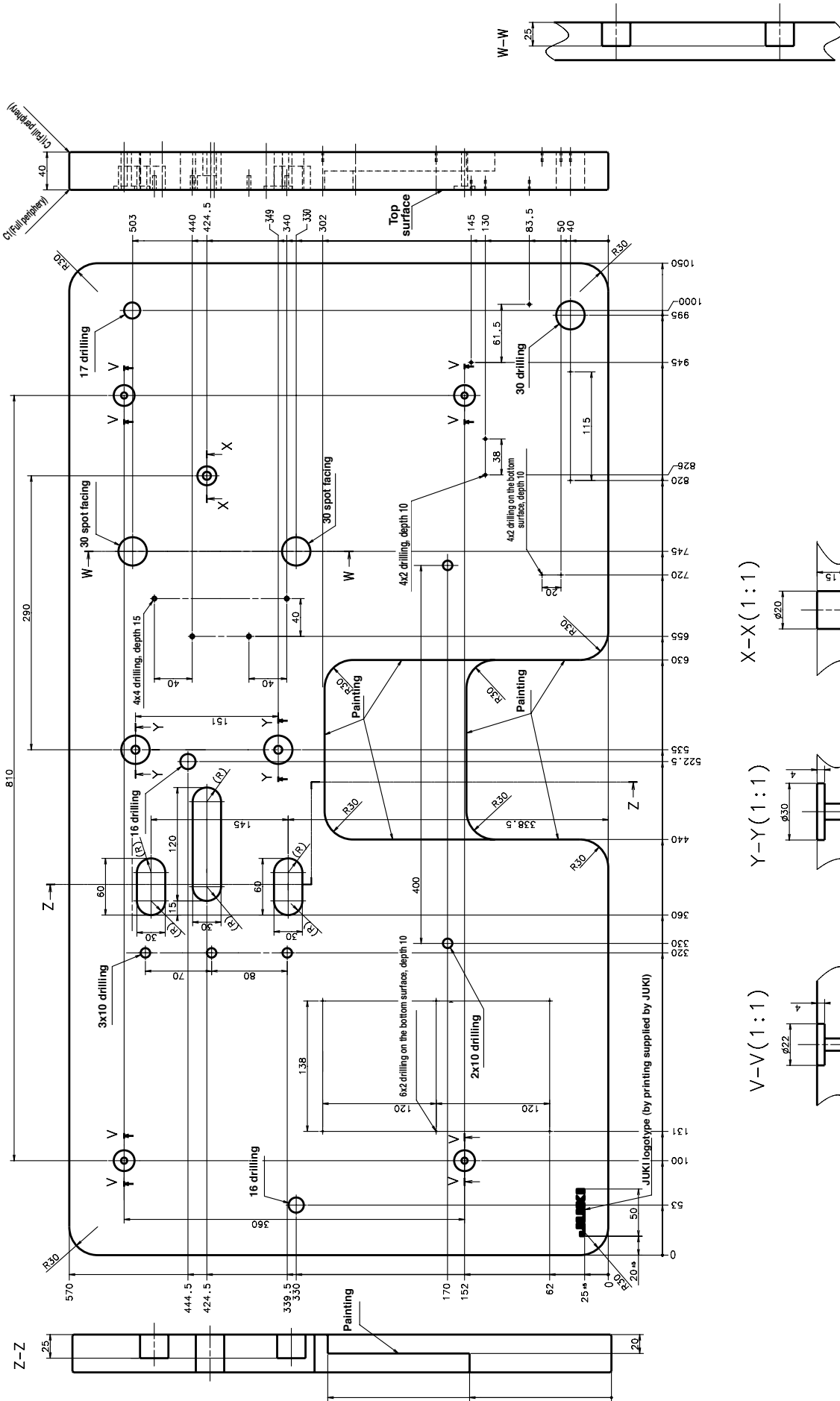

(2) Auxiliary table

Part No. : 17971805

