

SPECIFICATIONS

Model name	LU-2828V-7	LU-2860V-7
Type	1-needle, Unison-feed, Lockstitch Sewing System (Shorter - thread remaining type)	2-needle, Unison-feed, Lockstitch Sewing System
Max. sewing speed	3,500sti/min	
Max. stitch length	9.0mm	12.0mm
Presser foot	20mm	
Alternating vertical movement(DL)	9.0mm	
Needle thread tension	0~200	
Presser foot pressure	0~200	
Hook	Vertical axis 2.7 fold-capacity hook	Vertical axis 2.0 fold-capacity hook
Needle	134x35 Nm140 (#22) , Nm125~180 (#20~#24)	134x35 Nm160 (#23) , Nm125~200 (#20~#25)
Thread	60/3 ~ 20/3 (#30~#5)	60/3 ~ 10/3 (#30~#0)
Machine head weight	66Kg	68Kg

* "sti/min" stands for "Stitches per Minute."

WHEN YOU PLACE ORDERS

Machine head

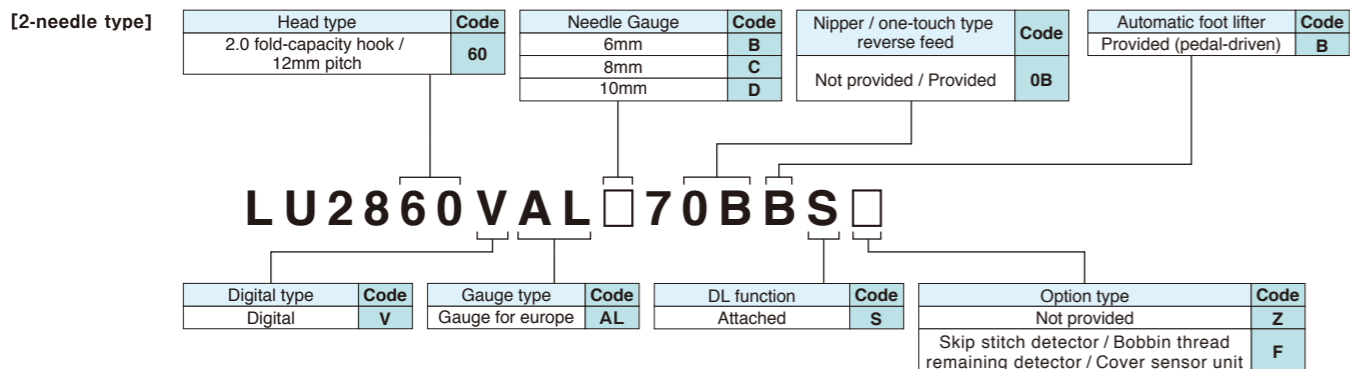
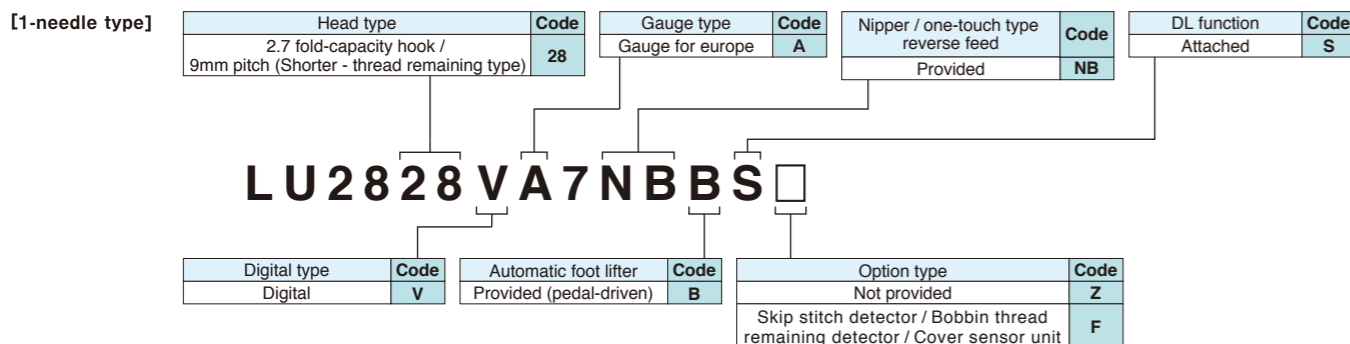

Control box

SC952A

Power supply	Code
Single-phase 100~120V	S
3-phase 200~240V	D
Single-phase 200~240V (for general export)	K
Single-phase 200~240V (for ce)	N
Single-phase 200~240V (for china)	U



Registered Organization : JUKI CORPORATION Head Office
The Scope of the Registration : The activities of research, development, design, sales, distribution, and maintenance services of industrial sewing machines, household sewing machines and industrial robots, etc., including sales and maintenance services of data entry systems.

JUKI
JUKI CORPORATION
SEWING MACHINERY & SYSTEMS BUSINESS UNIT

2-11-1, TSURUMAKI, TAMA-SHI,
TOKYO 206-8551, JAPAN
PHONE : (81) 42-357-2383
FAX : (81) 42-357-2274
http://www.juki.com

* Specifications and appearance are subject to change without prior notice for improvement.
* Read the instruction manual before putting the machine into service to ensure safety.
* This catalogue prints with environment-friendly soyink on recycle paper.

JULY, 2018 Printed in Japan(TN)

JUKI



**DIGITAL
SEWING
SYSTEM**

LU-2800V-7 Series

Semi-dry Direct-drive, Unison-feed, Lockstitch Sewing System
with automatic thread trimmer

Commitment to sewing
Next-generation sewing system



LU-2828V-7



LU-2860V-7

LU-2800V-7 Series

Management of sewing performance and sewing machine with JUKI's next-generation sewing system.

Machine is mounted with inbuilt NFC (Near Field Communication) and communication devices capable of a 2-way data transmission.

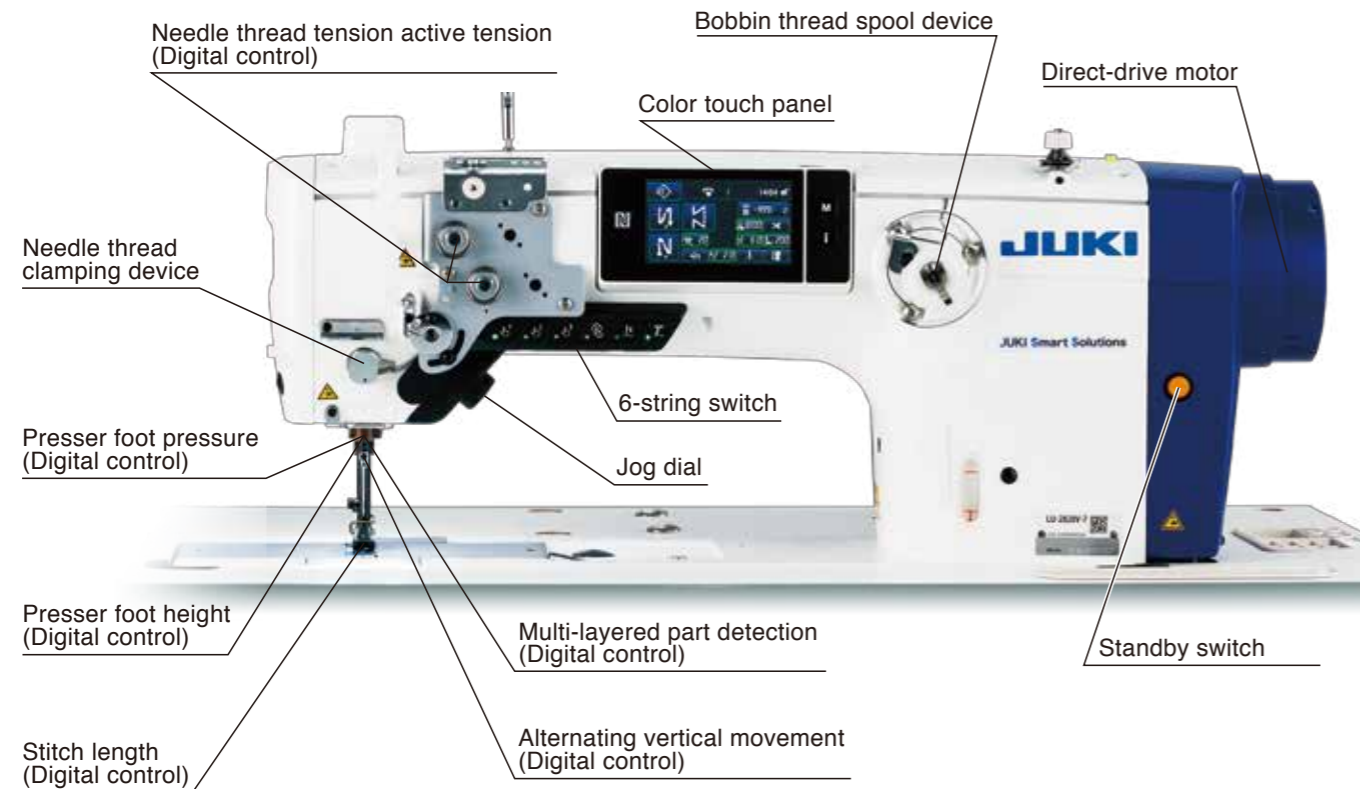

Standard equipment

Bobbin thread spool device

Bobbin thread spool device is no necessity of rolling thread manually.

Maintenance work carried out safely (Standby switch)

When the standby switch is pressed, the sewing machine does not start unexpectedly even if the pedal is depressed. When the standby switch is pressed, operations through the operation panel, and with the machine 6-string switch and jog dial are also disabled, thereby allowing sewing-machine maintenance work such as threading, needle replacement, gauge replacement to be carried out safely. (In this case, the pulley can be turned by hand.)

High-torque direct-drive motor is installed

The direct-drive motor system has been adopted by all of the sewing system with a thread trimmer. As a result, the sewing machine starts up swiftly and promises increased stop accuracy, thereby demonstrating improved responsiveness.

LED Light

The LED light can adjust the light intensity to 5 levels, and Off setting is also possible. The operator can set the brightness which is easy to work, improving work efficiency.



LU-2828V-7

Semi-dry Direct-drive, 1-needle, Unison-feed, Lockstitch Sewing System with automatic thread trimmer (Vertical axis 2.7 fold-capacity hook / Shorter - thread remaining type)

Shorter - thread remaining type

The shorter-thread remaining type LU-2828V-7 is a high-performance sewing machine. It leaves a shorter thread on the material at the beginning of sewing by means of the needle thread clamp device, as well as at the end of sewing by means of the thread trimmer which is provided with a shorter-thread remaining function. This means that manual thread nipping both at the beginning and at the end of sewing is no longer required, thereby helping reduce operator fatigue. Thanks to the adoption of a 2.7-fold hook, the frequency of bobbin thread changing is reduced and workability is improved.



Beautiful finished seams

Needle thread clamping device

This device pulls the needle thread into the wrong side of the material at the beginning of sewing, thereby ensuring more beautifully-finished seams.

The material at the beginning of sewing → The material at the end of sewing

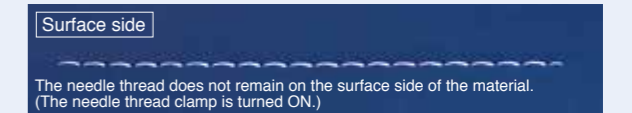

※LU-2828V-7 can produce the effect of shorter-thread remaining by making condensed stitch.

The shorter-thread trimming mechanism (needle thread roll-in and shorter-thread remaining type)

The thread trimming mechanism has been completely renewed. The industry's shortest remaining thread length achieved by trimming the thread close to the fixed knife at the last stitch (condensed stitch). (The length of remaining needle thread is 5mm)



LU-2860V-7

Semi-dry Direct-drive, 2-needle, Unison-feed, Lockstitch Sewing System with automatic thread trimmer (Vertical axis 2.0 fold-capacity hook / 12mm - pitch type)

High and long arm has been adopted.

The machine is suited to sew car seats, sofas and bags. It is a sewing machine provided with dramatically improved workability and functions which are required for sewing large products and extra heavy-weight materials.



Car seat



Bag



Sofa



The maximum stitch length is 12 mm

This model is the most-desired sewing machine for sewing furniture such as sofas. It is best-suited to topstitching with a stitch length of maximum 12mm-pitch. During the topstitching process, the longer distance from the machine arm to the bed, in particular, effectively demonstrates the machine's improved workability.

The maximum stitch length is 12 mm



General stitch length is 6mm



Various digitalized functions

Management of sewing performance and sewing machine by the utilization of IoT (Internet of Things)

New

Management, browsing and editing of data can be carried out on the application software

Data on sewing machine adjustments made according to the product to be sewn can be transferred to a commercially-available Android tablet in contactless mode. This enables quick check for uniform settings as well as confirmation of conditions of sewing machines in a sewing line, thereby facilitating setup changes. The operation panel is also provided as standard with a USB port. Data management and software update can be carried out with ease using a USB thumb drive.

Data items of sewing can be numerically managed to ensure "stable quality" and reduction in time required for setup changes. Quantified sewing data can be externally taken from the sewing machine using an Android tablet or USB thumb drive.

*Android OS Version 6.0 is recommended to use JUKI Smart APP.
(Operation is confirmed with respect to Versions 5.0 and later.)
Contact JUKI distributor in your area for how to use the application software.

 The sewing machine can be paired with equipment which supports NFC (Near Field Communication) only by holding the equipment over the sewing machine.



Adjustment of sewing condition is displayed on one screen

Sewing conditions can be set easy since sewing conditions such as thread tension, stitch length, presser foot pressure, alternate vertical movement amount, etc. are displayed on one screen.

Energy-saving effect

Automatic OFF function of the operation-panel backlight

The operation-panel light can be turned OFF after a lapse of the preset time.

Sleep mode (Automatic power-OFF function)

If no operation is carried out for a predetermined period of time, the power supplies to the motor, etc. can be automatically turned OFF.

*These options can be set up on the operation panel.

Adoption of the needle-thread active tension

Needle tension is digitally controlled

Needle thread tension which matches sewing conditions given can be set on the operation panel and stored in memory. The needle thread tension adjustment needs experience. However, for this sewing machine, thread tension data stored in memory is reproducible, thereby reducing the setup time when the product to be sewn is changed.

Example : Needle-thread active tension demonstrates its effectiveness in the topstitching process.

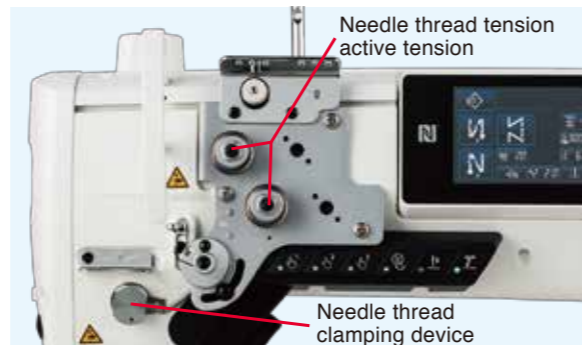

LU-2828V-7

Active presser foot pressure mechanism

The presser foot pressure is digitally controlled

Digital control system controls the presser foot pressure. Under the automatic mode, the multi-layered section detection function detects changes in material thickness to increase/decrease the presser foot pressure accordingly. Under the manual mode, the presser foot pressure control function is assigned to the hand switch to enable operation with the hand switch.

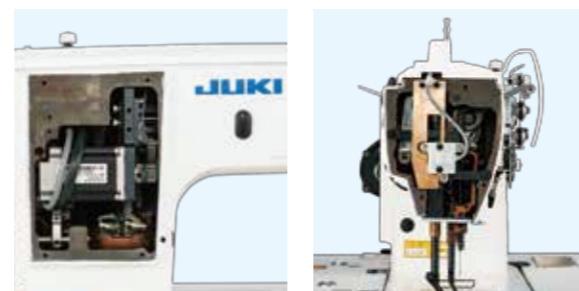

LU-2828V-7

Multi-functional 6-string switch

Sewing conditions can be changed to the best-suited ones only with the one-touch changeover switch.

The sewing data (stitch length, needle thread tension, amount of alternate vertical movement, presser foot pressure and sewing speed) can be changed easily with the one-touch changeover switch to obtain the ones that have been elaborated according to sewing conditions. The sewing data (stitch length, needle thread tension, amount of alternate vertical movement, presser foot pressure and sewing speed) can be changed easily with the one-touch changeover switch to obtain the ones that have been elaborated according to sewing conditions. Four different one-touch functions can be assigned to six-gang hand switches ① to ⑥, touch-back switch and jog dial, at the maximum. (*For the initial settings, the one-touch functions are assigned to 6-gang switches ① to ③.)

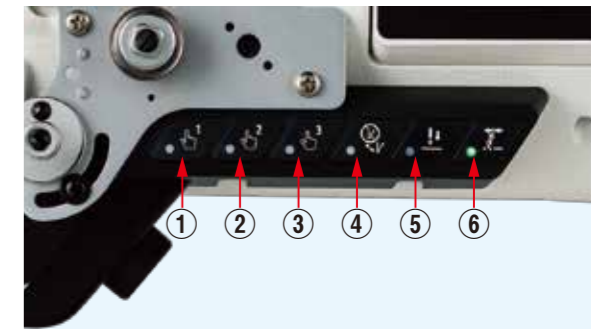

① to ③: One-touch changeover function
④: Automatic reverse feed stitching changeover switch
⑤: Needle-entry alignment switch
⑥: Thread clamp switch

Improvement of operability by means of the jog dial

The operator is able to turn the main shaft (for moving the needle bar up and down) only with the jog dial without stretching his/her arm to the handwheel.

When the jog dial is pushed, it can be used as 1/2 needle-stitch correction switch (one touch function).



Best-suited stitches are produced at multi-layered parts of material.

Multi-layered part detection function

Multi-layered parts of material which occur in the case two or more plies of material are sewn or different kinds of material are sewn can be detected by the multi-layered part detection function to change over the stitch length, thread tension, presser foot pressure and amount of alternate vertical movement to those that have been predetermined for sewing those parts of material.

Setting of thresholds for the multi-layered part detection

Under the teaching mode for the multi-layered part changeover ON sensor value, the material thickness at the normal part and that at the multi-layered part of material can be measured with ease.

The automatically-measured thresholds can be set as those for the multi-layered part detection.

Other continuous sewing conditions

For settings corresponding to continuous sewing conditions (polygonal shape stitching function), more beautifully finished seams are produced by using various functions (custom-pitch setting function, reverse-feed stitching function).

Example) Sewing conditions in the case of using the polygonal-shape stitching function (LU-2828V-7)

In the case of sewing materials 1 and 2 that differ in thickness to the base material (material thickness), the sewing conditions can be easily changed over to the best-suited ones on a step-by-step basis. (The number of stitches, one-touch changeover and multi-layered part detection are used as the step-by-step changeover triggers.)

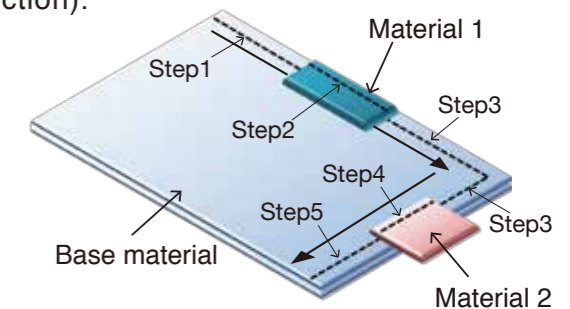

Smart Devices Options (to be mounted by manufacturers)

Cover Sensor Unit

The cover sensor unit detecting ①, ② and ③ (shown below) are closed tightly during sewing, thereby preventing the sewing machine from starting up unexpectedly. (①, ② and ③ can be used discretely.)



① Eye guard with an open/close sensor



■ The eye guard prevents a broken needle from flying off. If the eye guard is open, the sewing machine cannot be started. As a result, the sewing machine will not start up unexpectedly even if the operator forgets to turn the power off.

② Bed slide with an open/close sensor



■ The sewing machine will not start if the throat plate is open. This prevents the material from being caught in the hook during sewing.

③ Handwheel cover with an open/close sensor



■ In a situation where the power is on, the handwheel cover with the open/close sensor prevents the sewing machine from starting suddenly. In addition, the cover prevents thread and material from being caught in the handwheel during sewing.

Skip Stitch Detector

Stitch skipping is detected during sewing. This helps lighten the operator's inspection work load and also prevents defective products from being shipped. In the case where a skipped stitch is detected, the buzzer sounds up and the sewing machine stops. With this function, the operator is allowed to concentrate on sewing work without worrying about skipped stitching.

Bobbin Thread Remaining Detector

The buzzer sounds up when the amount of thread remaining on the bobbin reaches a predetermined length. It is also possible to stop the sewing machine at this point. With this function, the operator is allowed to concentrate on sewing work without caring about the amount of thread remaining on the bobbin. Remaining on the bobbin reaches a predetermined length. It is also possible to stop the sewing machine at this point. With this function, the operator is allowed to concentrate on sewing work without caring about the amount of thread remaining on the bobbin.

JUKI ECO PRODUCTS	LU-2828V-7 is an eco-friendly product which complies with JUKI ECO PRODUCTS standards for protecting the environment.
	<p>● The sewing machine complies with the "Juki Group Green Procurement Guidelines" on the use of hazardous substances, which is stricter than other restrictions, such as those of the RoHS Directive.</p> <p>For details of JUKI ECO PRODUCTS, refer to: http://www.juki.co.jp/eco_e/index.html</p> <p><small>*The RoHS Directive is an EU Directive limiting the use of 6 hazardous substances (lead, hexavalent chromium, mercury, cadmium, PBB and PBDE) in electrical and electronic equipment. The Juki Green Procurement Guideline is the voluntarily established criteria to eliminate not only the aforementioned six substances, but also other ones which also adversely affect the environment.</small></p>

List of Gauges (1-needle type)

List of gauges for the LU-2828V-7

Model	Throat plate	Feed dog	Walking foot	Presser foot	Slide plate of left	Slide plate of right	Front bed slide
	LU-2828V-7 LU-2828V-7/SD	40190399	40135816	10711653	10712552	40127056	40147944 40162128

*SD: Smart Devices

Optional walking foot for the LU-2828V-7

Size (mm)	Piping		Piping	
	Walking foot	Presser foot	Walking foot	Presser foot
3mm	10745354	10747350	10746352	10747350
4mm	10745453	10747459	10746451	10747459
5mm	10745552	10747558	10746550	10747558
6mm	10745651	10747657	10746659	10747657

* For general piping

* The needle position with respect to the pipe is adjustable.

Right single-sided presser for sewing material edges		Left single-sided presser for sewing material edges		Wider type with increases efficiency of feed		For heavy-weight sponges Suitable for highly resilient materials	
Walking foot	Presser foot	Walking foot	Presser foot	Walking foot	Presser foot	Walking foot	Presser foot
10711851	10712859	10711950	10712958	10712057	10713055	10711752	10712750

For multi-layered sections Dual-purpose type for both multi-layered sections and flat sections of material		For multi-layered sections with a smoother feed of both multi-layered and flat sections of material		Narrow width type for improved handling of matter		Side plate with a window for the LU-2828V-7	
Walking foot	Presser foot	Walking foot	Presser foot	Walking foot	Presser foot	Side plate with window	
10711653 (Standard)	10758456	10711653 (Standard)	10712651	40160493 +SM6040552TP	40160495	LU-2828V-7 40155087	

*Can not be mounted on smart devices.

List of Gauges (2-needle type)

List of gauges for the LU-2860V-7

Model	Gauge set			Throat plate	Feed dog	Needle clamp Asm.	Feed foot Asm.	Presser foot Asm.	Slide plate	Front bed slide
	Code	Gauge set No.	Size	Part No.	Part No.	Part No.	Part No.	Part No.	Part No.	Part No.
LU-2860V-7 LU-2860V-7/SD	B	40155973	6mm	40147951	40126142	40038778	40135589	10781656	40147945 40198302	40112210
LU-2860V-7 LU-2860V-7/SD	C	40155974	8mm	40147952	40126143	40038776	40135590	10781755	40147945 40198302	
LU-2860V-7 LU-2860V-7/SD	D	40155975	10mm	40147953	40126144	40038774	40038898	10781854	40147945 40198302	
LU-2860V-7 LU-2860V-7/SD	E	40155976	12mm	40147954	40126145	40038772	40095748	10781953	40147945 40198302	

*The [bed slide] is not included in the gauge set. (For the 6 to 12 mm gauges, the bed slide which is provided as standard at the time of shipment is applicable.)
*The finger guard is a component included in the presser foot (asm.).

Optional walking foot for the LU-2860V-7

Walking foot with groove (needle hole: 2.1mm)	
Needle gauge (mm)	Part No.
6	10783157
8	10783256
10	10783355
12	10783454

*The needle hole in the sole of the walking foot has a slit (1 mm in width and 0.5 mm in depth) on the opposite side of the operator.
*Please use the "presser foot asm." of "List of gauges for the LU-2860A".

Presser foot with center guide for the LU-2860V-7

Needle gauge (mm)	Walking foot	Presser foot
	6	40038854*1
8	40038852*1	40038808
8	40067204*2	
10	40038850*1	40038806
10	40039271*2	
12	40038848*1	40038802
12	40095750*2	

*1 Diameter of the needle entry hole in the walking foot: ϕ 2.1mm
*2 Diameter of the needle entry hole in the walking foot: ϕ 3mm

Side plate with a window for the LU-2860V-7

Side plate with window (right & left)
LU-2860V-7 40156017