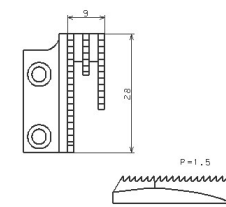
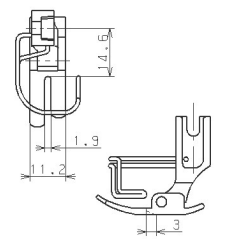
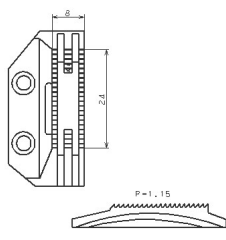
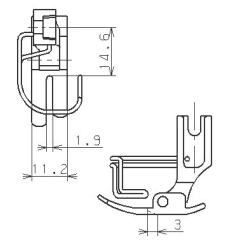
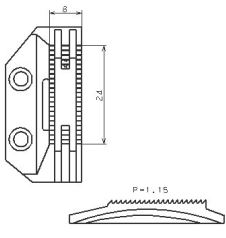
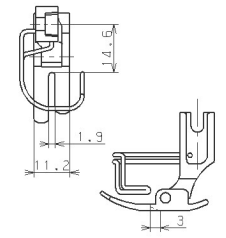
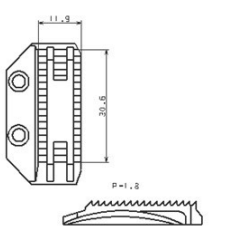
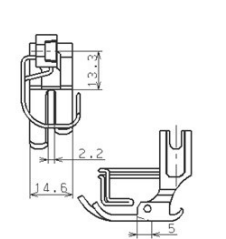
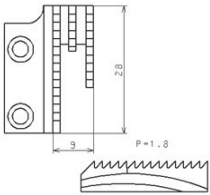
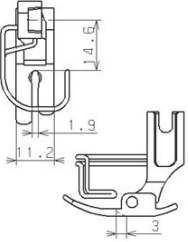
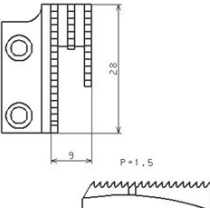
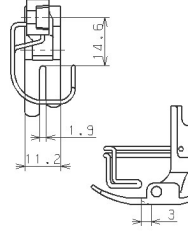
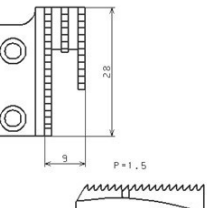
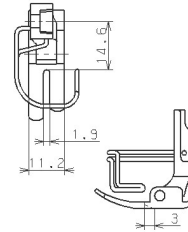
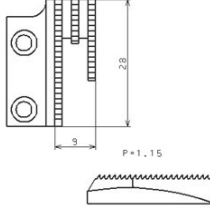
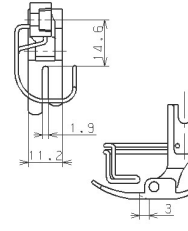
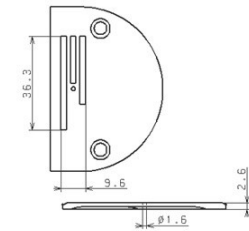
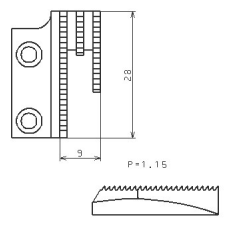
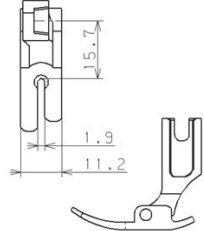
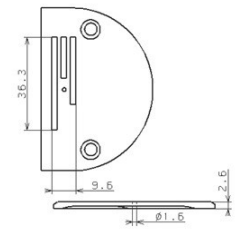
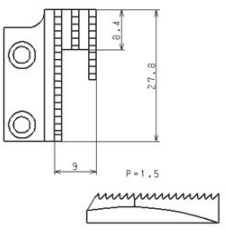
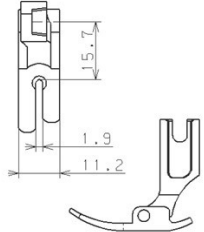
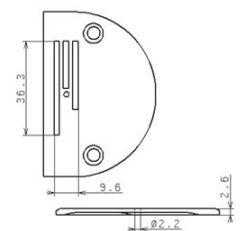
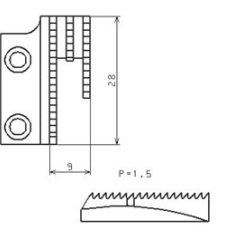
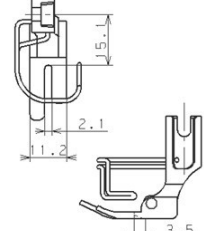
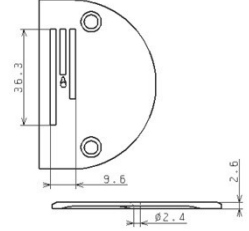
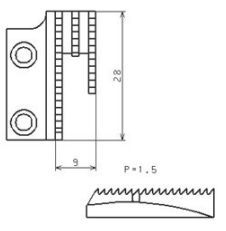
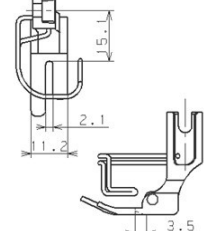
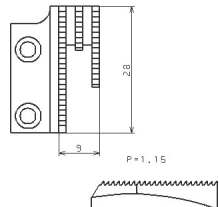
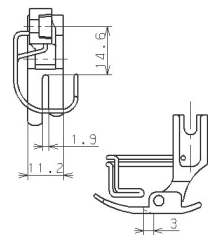
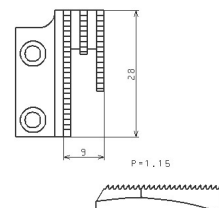
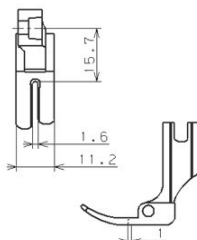
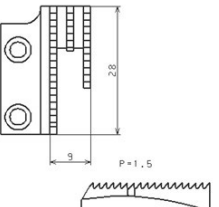
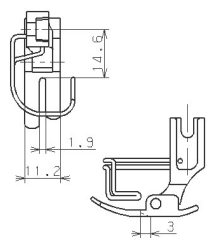
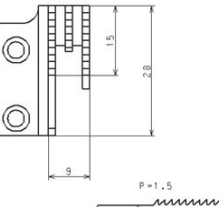
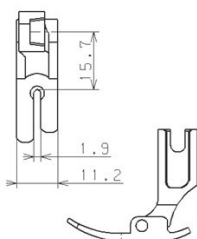
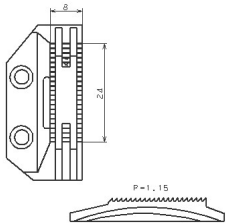
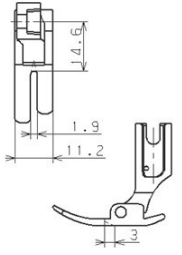
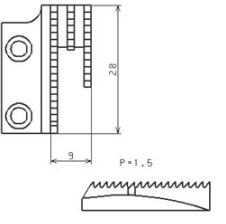
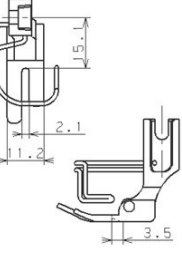
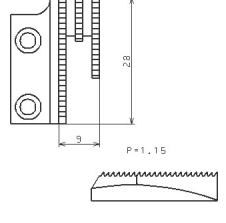
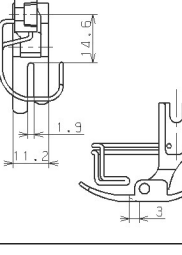
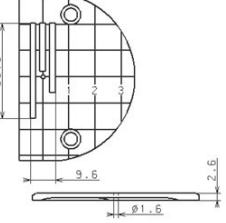
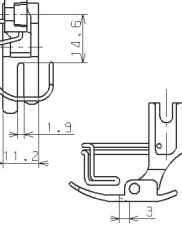

C/N	Throat plate		Feed dog		Presser foot		Comment
	Part No.	shape	Part No.	shape	Part No.	shape	
1	1001	11028008	23614506		B15240120BA		Standard for Japan, throat plate in millimeters
2	1002	B110901210B	B1613012100		B15240120BA		Standard for general export and Europe, throat plate in millimeters
3	1003	40182291	B1613012100		B15240120BA		Standard for China, throat plate in millimeters
4	1004	40089605	11403003		D1524555EBL		H type standard for general export, the Europe, and Japan

C/N	Throat plate		Feed dog		Presser foot		Comment
	Part No.	shape	Part No.	shape	Part No.	shape	
5	1005	11062007	11062601		40064839		9000C H type standard for China
6	1006	B1109012A00	B1613012A00		B15240120BA		Throat plate satin nickel plating
7	1007	B1109012A0F	B1613012A00		B15240120BA		Squares displayed in millimeters on the throat plate B1109012A00 (10mm intervals)
8	1008	11028008	B1613012B00		B15240120BA		Throat plate in millimeters, feed pitch 1.15mm (Suitable for sensitive materials)

C/N	Throat plate		Feed dog		Presser foot		Comment
	Part No.	shape	Part No.	shape	Part No.	shape	
9	1009	B1109012F00 	B1613012B00 	B1524012TA0 	Throat plate satin nickel plating, no thread relief on the backside of the presser foot (Thread tightening becomes loose.)		
10	1010	B1109012T0B.png 	B1613012T00.png 	B1524012TA0.png 			
11	1011	B1109012B00 	B1613012A00 	B15245520BA 	Throat plate satin nickel plating. The stitch of the presser foot is well-tightened.		
12	1012	B1109012E00 	B1613012A00 	B15245520BA 	The thread relief of the throat plate is 1.6mm behind the hole, satin nickel plating. The stitch of the presser foot is well-tightened.		

C/N	Throat plate		Feed dog		Presser foot		Comment
	Part No.	shape	Part No.	shape	Part No.	shape	
13	1013	D1109126W00	B1613012B00		B15240120BA		Throat plate satin nickel plating, suitable for puckering prevention
14	1014	11028008	B1613012B00		D1524555BA0		Throat plate in millimeters, thread relief of the presser foot: 1mm (Stitch tightness is loose.)
15	1015	11001708	B1613012A00		B15240120BA		The needle hole thread relief on the backside of the throat plate is large (good stitch tightness). Satin nickel plating
16	1016	B1109012A0C	B1613012A0C		B1524012TA0		There is processing in front of the throat plate, feed dog only the rear side (easy to sew from the edge of the material) No thread relief on the backside of the presser foot

C/N	Throat plate		Feed dog		Presser foot		Comment
	Part No.	shape	Part No.	shape	Part No.	shape	
17	1017	B1109012I0B	B1613012I00		11028156		S standard shape presser foot with satin nickel plating (good slip)
18	1018	B1109012B0F	B1613012A00		B15245520BA		Squares displayed in millimeters on B1109012B00 (10mm intervals) The stitch of the presser foot is well-tightened.
19	1019	B1109012F00	B1613012B00		B15240120BA		Throat plate satin nickel plating, small feed pitch
20	1020	B1109012F0F	B1613012B00		B15240120BA		Squares displayed in millimeters on the throat plate B1109012F00 (10mm intervals)

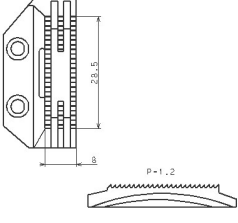
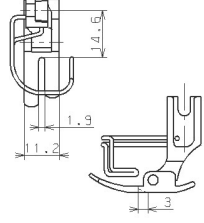
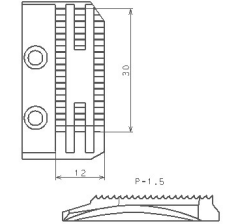
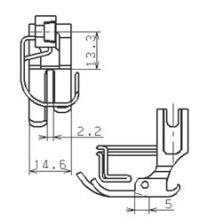
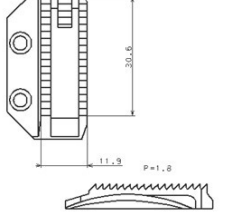
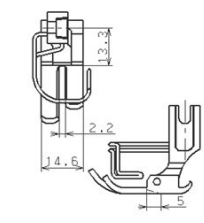
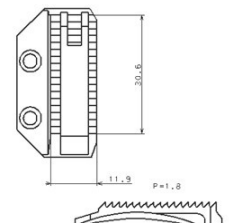
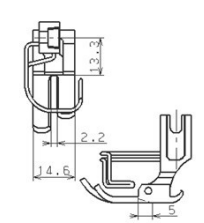
C/N	Throat plate		Feed dog		Presser foot		Comment
	Part No.	shape	Part No.	shape	Part No.	shape	
21	1021	B1109555C00	B1613555C00		B15240120BA		Throat plate satin nickel plating, long length of feed dog (good straightness)
22	1022	B1109555D00	B1613555D00		D1524555EBL		Throat plate satin nickel plating. The needle hole is a 1.8 x 2.5mm slotted hole and the stitch tightness is good.
23	1023	B1109555H0B	B1613555H00		D1524555EBL		3-row teeth old H type gauge set
24	1024	11074101	B1613555H00		D1524555EBL		B1109555H0B with throat plate marker line added (in millimeters)

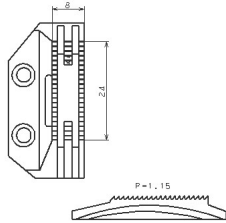
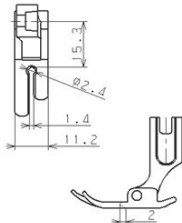
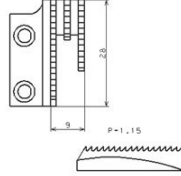
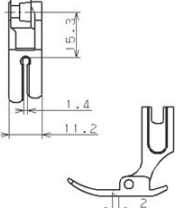
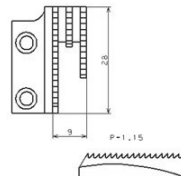
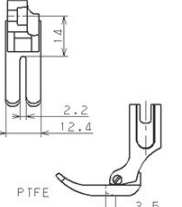
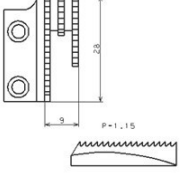
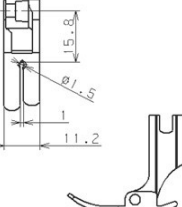
C/N	Throat plate		Feed dog		Presser foot		Comment
	Part No.	shape	Part No.	shape	Part No.	shape	
25	1025	B1109555I0N	B1613012I00		B1524555DAN		NEDOX treatment on throat plate and presser foot (good slip)
26	1026	B1109555R00	B1613555R00		D1524555DA0		Small thread relief of the presser foot, effective against puckering
27	1027	D1109126W00	B1613555R00		D1524126WA0		Throat plate satin nickel plating, Teflon resin presser foot (good slip)
28	1028	D1109126W0F	B1613555R00		D1524155WA0		Squares displayed in millimeters on the throat plate D1109126W00 (10mm intervals), Needle slot of presser foot 1mm, effective against puckering

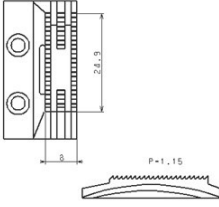
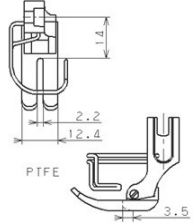
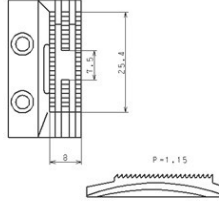
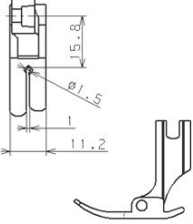
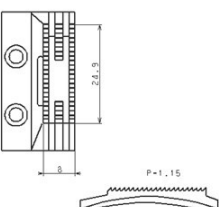
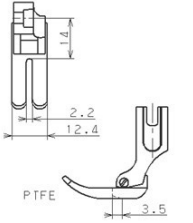
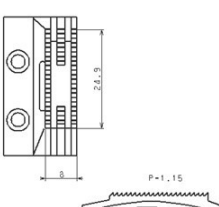
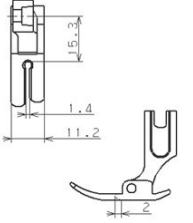
C/N	Throat plate		Feed dog		Presser foot		Comment
	Part No.	shape	Part No.	shape	Part No.	shape	
29	1029	D1109155W00	D1613155W00		D1524126WBA		Throat plate satin nickel plating, for feed dog pitch of 2.5mm or less Teflon resin presser foot (good slip)
30	1030	D1109155W00	D1613155W0D		D1524155WA0		Throat plate satin nickel plating, for feed dog pitch of 2.5mm or less, presser foot with needle slot of 1mm Effective against puckering
31	1031	D1109155W0F	D1613155W00		D1524126WA0		Squares displayed in millimeters on the throat plate D1109155W00 (10mm intervals) For feed dog of small pitch, Teflon resin presser foot
32	1032	D1109555D0W	D1613155W00		D1524555DA0		For feed dog pitch of 2.5mm or less, thread relief of the presser foot: 2mm Puckering prevention

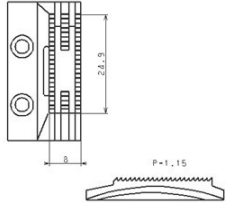
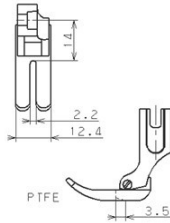
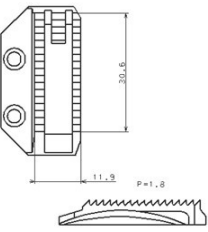
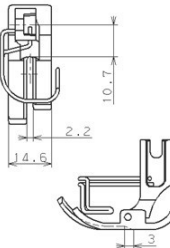
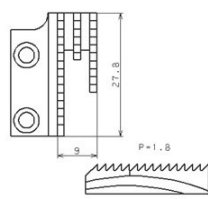
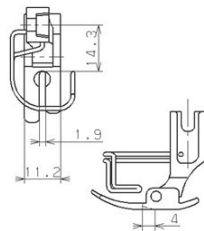
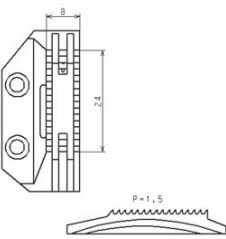
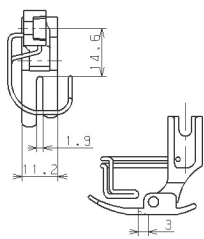
C/N	Throat plate		Feed dog		Presser foot		Comment
	Part No.	shape	Part No.	shape	Part No.	shape	
33	1033	D1109555D0W	D1613155W00		D1524126WA0		For feed dog pitch of 2.5mm or less, Teflon resin presser foot (good slip)
34	1034	B1109555H0B	B1613555H00		B1524041EB0		The thread relief of the presser foot behind the needle entry is extra large (suitable for long pitch).
35	1035	11080009	11080603		11080371		Throat plate satin nickel plating, needle hole thread relief in front and back Relief of the presser foot: 4mm (good stitch tightness)
36	1036	40182291	40133950		B15240120BA		M type. The stitch tightness and feeding force are better than the 4-row teeth standard gauge.

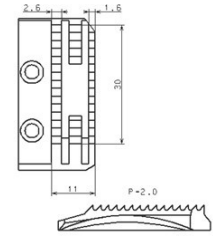
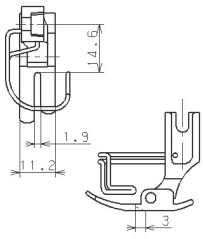
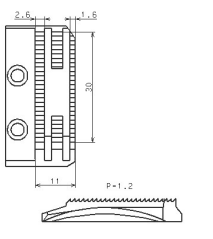
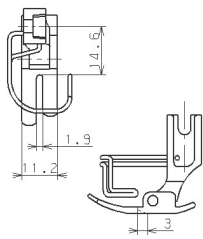
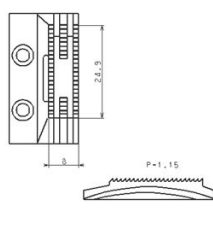
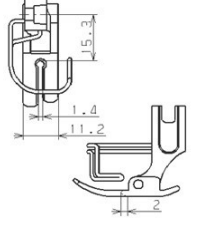
C/N	Throat plate		Feed dog		Presser foot		Comment
	Part No.	shape	Part No.	shape	Part No.	shape	
37	1037	B1109555000	B1613555A00		B15240120BA		Throat plate satin nickel plating, needle hole 1.8×2.7mm, feed dog 1.6-3.2-2.6mm (feed dog right, small width)
38	1038	B1109555000	B1613555B00		B15240120BA		Throat plate satin nickel plating, needle hole 1.8×2.7mm, feed dog 1.6-3.2-2.6mm (feed dog right, small width)
39	1039	11001906	D1613155W00		D1524555DBA		Throat plate in millimeters, satin nickel plating For feed dog pitch of 2.5mm or less